

**ACTIVATION DOSE RATE IN ACCESS TO THE
INNER DETECTOR**

V.A.Klimanov, E.I.Kulakova, M.N.Morev, V.K.Sakharov

ISTC Project #1800-p

Abstract

The present note reports on the results obtained in evaluating activation dose rate for long-access scenario to the inner detector. Contributions of individual materials/systems to activation dose rate are studied. Activation dose rate fields for different opening layouts are calculated.

Moscow, 14 May 2004

1. Introduction

Being operated in harsh radiation environment, the ID detector is to be activated to a significant level that makes problems for maintenance procedures. Induced radioactivity is produced by elementary particles and depends on flux, energy spectra of the particles, activation cross-section, type and mass of irradiated material, exposure time and time after shut down.

Interactions of hadrons with stable nuclei produce most contribution to induced radioactivity. From the methodical viewpoint, it is convenient to divide the energy range onto two sub-ranges: (1) from thermal energies to 20 MeV, and (2) above 20 MeV. The point is that different processes of radionuclide production predominate in the energy ranges. At energy below 20 MeV, neutron induced reactions like (n,γ) , (n,p) , (n,α) , and $(n,2n)$ predominate. While, at energy above 20 MeV hadron-induced spallation reactions $(x,Spall)$, where X is proton, neutron, Pi^+ , or Pi^- , are most important. The division is also convenient due to different representation and availability of activation cross-sections. Neutron cross-sections are studied well enough for energy region below 20 MeV, as they are widely used in reactor applications. For energy above 20 MeV activation cross-sections are usually studied in less detail. As a rule, only proton cross-sections are studied well enough and used as estimation for other hadrons—neutrons and pions.

The note reports on the results achieved during the implementation of the ISTC #1800-p project. The basic aim for the note is to present preliminary evaluation of activation dose rate in the ID long-access scenario on the base of previously developed activation code and associated data sets.

The results reported in the note should be treated as preliminary estimation because the ID design is not yet finalized and a great attention is made to outline the need for more correct estimation of material inventory.

In the general long-access scenario [1] the following systems will contribute to radiation environment: LAr Barrel and EndCap Calorimeter, Inner detector beam-pipe (VI), LAr beam-pipe (VA), Pixel Detector, Semiconductor Tracker (SCT), Transition Radiation Tracker (TRT), and their services. Activation dose rate field produced by every separate system/subsystem is calculated for different exposure and cooling time assumptions, but due to extremely large volume of the obtained data here we give only summary results. A more detailed data is available and may be useful for estimating doses in scenarios involving disassembly of the inner detector. As soon as such scenarios will be developed, the activation dose rate fields at any dismantling step may be easily got as superposition of doses from the systems which are still in place.

All the results are normalized to nominal beam-luminosity $10^{34} \text{ cm}^{-2}\text{s}^{-1}$.

2. The simulations

2.1 Induced activity

It is convenient to use activation integral (production rate) for calculation of induced activity. The integral, calculated per one target nuclear, shows the rate of a nuclear reaction:

$$q = \int_0^{\infty} \sigma(E)\varphi(E) dE,$$

where, $\sigma(E)$ - activation cross-section, $\varphi(E)$ - flux of particles.

Having solved the balance equation for the number of radioactive nuclei, one could come to the formula for activity A , Bq per unit volume

$$A_v = nq(1 - \exp(-\lambda T))\exp(-\lambda t) \quad (1)$$

where λ is the decay constant, $\lambda = \ln(2)/T_{1/2}$ and $T_{1/2}$ is half life;
 n - number of target nuclei per unit of volume;
 T - is exposure time in the steady flux;
 t - time after shut down.

In (1) we disregard any burning-out processes for both stable and target nuclei. The same expressions one could formulate for the daughter radioactive nuclei produced by radioactive decay of radionuclide - the product of nuclear reaction. Practically, it is enough to consider a mass-chain of three radioactive nuclei, as there is not a radionuclide with half decay exceeding few hours, which would have a longer mass-chain.

In the case the flux (luminosity) cannot be considered as steady in time, its possible to approximate it with a step-wise function of time. So that, the formula (1) will transform into the following:

$$A_v = \frac{nq_{nom}}{W_{nom}} \left\{ \sum_{j=1}^J W_j (1 - \exp(-\lambda \Delta T_j)) \exp\left(-\lambda \left(t + T - \sum_{i=1}^j \Delta T_i\right)\right) \right\} \quad (2)$$

where q_{nom} - is activation integral calculated for the nominal W_{nom} luminosity; W_j - luminosity during the time period ΔT_j ; $T = \sum_{j=1}^J T_j$ - full exposure time.

Number of target nuclei per unit volume in formulas (1) and (2) are calculated using:

$$n = P\rho N_A / A, \quad (3)$$

where, P - natural abundance of the isotope in the material; ρ - density; N_A - Avogadro constant; A - atomic weight of the element.

Being defined as number of decays per second (Bq), activity is not a really convenient value. Activation processes results in great many radionuclides, which properties vary greatly. Since every material (and subsystem) in every particular moment of time will have a unique radionuclide inventory, it is impossible to conclude which of them is more dangerous by their activity only. A more convenient value is the so-called "gamma-equivalent" defined as the product of gamma-factor Γ by activity. Gamma-equivalent k_e , $\text{Sv} \cdot \text{m}^2 \cdot \text{s}^{-1}$, is equal to the dose rate from a point-wise radionuclide source with activity A at the distance 1 m without any shielding.

$$k_e = A\Gamma_H,$$

$\Gamma_H, \frac{\text{Sv} \cdot \text{m}^2}{\text{Bq} \cdot \text{s}}$, is "gamma-factor", which is constant for a given radionuclide emitting I

gamma rays with different energy E_{0i} , MeV and absolute intensity n_i , photons per decay:

$$\Gamma_H = \frac{\sum_{i=1}^I (E_{0i} n_i \mu_{en,m}^{tiss}(E_{0i}) w)}{4\pi} 1.602 \cdot 10^{-13} \quad (5)$$

where $\mu_{en,m}^{tiss}(E_{0i})$ - mass energy attenuation coefficient for energy E_{0i} emitted by the radionuclide in the biological tissue, m^2/kg ;

$w = 1 \text{ Sv/Gy}$ - tissue weighting factor for photons;
 Factor 1.602×10^{-13} is used to transform energy E_{0i} from MeV to Joles.

If the activated material contains more than one radionuclide, then the gamma-equivalent will be the sum for all the radionuclides.

Since the gamma-equivalent is defined as dose rate from point-wise radionuclide source, it is quite a convenient value to compare radioactive sources of arbitrary radionuclide inventories. In addition, if one can disregard self-attenuation of photons in a source of complex geometry, the dose rate will correlate with the total gamma-equivalent¹.

The described methods for simulation of induced activity and gamma-equivalent have been implemented in the ACTIVATION-2 code [2,3]. In addition, the code allows to calculate a distributed volume source of photons, which is used in the study as input for simulation of photons transport with radiation transport codes DOT-III [4]. The ACTIVATION-2 code is equally applicable for study of both low energy neutrons and high-energy hadron activation if relevant group activation cross-sections libraries are available.

2.2 Dose rate

Both simple engineering methods and radiation transport codes are used in the present study to simulate dose rate fields. Engineering methods are based on simplification of real geometry and radiation source distribution that enables an analytical solution. A complex geometry can be represented as a set of sources of simple shape and dose rate will be the sum over the sources. Being properly used, engineering methods allow to get rather a precise estimation for dose rate. Though applicability of every particular method is limited, and its use must be justified on case-by-case basis. If geometry is complex enough or radiation source is not uniform, the only way to get correct solution is to use venerable codes for simulating radiation transport in real geometry. In this study we use DOT-III two-dimensional discrete ordinate radiation transport code.

The average density of material in the Inner Detector is rather low. As a result, one can disregard attenuation of gamma radiation in materials of the detector. To estimate dose rate from VI beam-pipe, VA beam-pipe, Pixel, SCT, TRT, and their services we use the following engineering method.

An Inner Detector sub-volume was represented as a set of thin circular radiation sources with the center positioned on the Z-axis and dose rate in a point (Z_0, R_0) is sum of contributions from all the sources:

$$\dot{H} = 3600 \sum_i \frac{k_i}{\sqrt{(R_0^2 - R_i^2)^2 + 2(Z_0 - Z_i)^2(R_0^2 + R_i^2) + (Z_0 - Z_i)^4}} \quad , \quad (8)$$

where \dot{H} - equivalent dose rate, Sv/h,
 k_i is gamma-equivalent of source i , Sv.m²/s;

R_i and Z_i - radius of the ring and its position along z-axis, m.

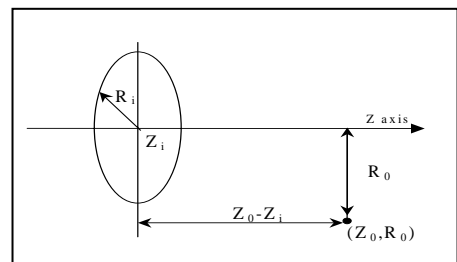

¹ Dose from localized source correlates with total gamma-equivalent; dose on the surface of thick (with considerable self-absorption) source correlates with specific gamma-equivalent; dose rate from extended low-density source (negligible self-absorption) correlates with volumetric gamma-equivalent.

At that the doses will be somewhat conservative as no attenuation of gamma radiation in the source was taken into account. In addition, one should carefully consider partitioning of the source— finite size of Z/R mesh should be much less than the distance to the point where the dose is calculated (because dose rate for $Z_i=Z_0$ and $R_i=R_0$ is infinitely high). As a result, dose rate may be overestimated in the region close to the source surface by some 30%.

Dose rate fields from LAr calorimeter were calculated with DOT radiation transport code and DLC-23/CASK cross-section library [5]. Calculations were done in P_3 approximation of cross-section angular dependence and S_{16} flux angular mesh with distributed photon source simulated by ACTIVATION-2 code.

3. Input data

In order to simulate induced activity one should know:

- flux and spectra of incident particles;
- cross-section of nuclear reactions producing radioactive nuclei;
- concentration of target nuclei and the geometry;
- operation scenario: time of operation T and time of cooling t .

3.1 Hadron Fluxes

Fluxes in the region $0 < R < 12$ m, $0 < Z < 24$ m were produced by Mike Shupe with GEANT/GCALOR. The following data together with a readback procedure are available [6]:

- Fluxes with step by z-axis $\Delta Z=10$ cm and step by r-axis $\Delta R=0.1$ cm ($0 < R < 4$ cm), $\Delta R=1$ cm ($4 < R < 120$ cm), and $\Delta R=1$ cm ($120 \text{ cm} < R$)
 1. High energy neutrons above 20 MeV;
 2. Fast neutrons - 2.19 MeV to 20 MeV;
 3. Intermediate neutrons - 3.78 keV to 2.19 MeV;
 4. Moderated neutrons - 0.414 eV to 3.78 keV;
 5. Thermal neutrons - $10E-5$ to 0.414 eV;
 6. Protons above 20 MeV;
 7. Pi minus above 20 MeV;
 8. Pi plus above 20 MeV;
 9. Stars, threshold 50 MeV.
- Neutron spectra on 10 cm x 10 cm grid ($R < 50$ cm) and 100 cm x 100 cm ($0 < R < 500$ cm) grid, 61 energy groups.
- Charged hadron spectra on 10 cm x 10 cm grid ($R < 50$ cm) and 50 cm x 50 cm ($0 < R < 500$ cm) grid, 21 energy groups:
 1. protons,
 2. π^- pions,
 3. π^+ pions.

The data was calculated for baseline geometry of November 2001.

3.2 Cross-sections

Cross-sections of nuclear reactions producing radioactive nuclei are usually available in form of data libraries.

Historically, neutron cross-sections, ranging from thermal energies up to 20 MeV,

are studied rather well, because they are extensively used in fission reactor applications. There are a number sources available, e.g ENDF, JANDL, IRDF.

Calculated proton cross-sections for threshold reactions are available up to energy 200 MeV from MENDL-2 data library [7]. Proton reaction data up to energy 10 GeV are also available in the form of experimental or calculated data compilations for a limited list of materials [8,9].

Cross-section data set for protons was prepared in the same energy group structure as flux spectra. By now the data set includes Be, C, N, O, F, Al, Ar, Ti, Mn, Fe, Ni, Cu, Au, Pb. For other elements we use cross-sections of material with a most close atomic number. For example, in the study we use cross-sections for Mn instead of Cr, Cu instead of Zn, and Pb instead of W.

There were no pion activation cross-sections data found so far. For the purpose of this study, proton cross-sections are used for all hadrons with energy above 20 MeV. The estimation is rather valid for neutrons and results are certainly conservative for pions (up to 30%), that can be concluded from the energy dependence of hadrons inelastic cross-sections.

3.3 Geometry and Concentrations

3.3.1 LAr Calorimeter

LAr calorimeter geometry/materials were adopted from geometry/material description file (version of November 2001) used by Mike Shupe for hadrons transport calculation with GEANT/GCALOR [6].

Barrel calorimeter geometry description and material composition are given in Tables 1 and 2. EndCap calorimeter geometry description and material composition are given in Tables 3 and 4.

The GEANT/GCALOR geometry data file is rather comprehensive to reflect all the distinct features relevant to radiation transport, but for the purpose of activation study it is desirable to know concentration of some minor chemical element (impurities) as well. Concentration of the impurities such as Co, Ag, Sb is negligible for radiation transport, but activation of the impurities by thermal neutrons result in production of long-lived radionuclides and may dominate dose rate in some cases. Since no concentrations of the impurities are available, we have to use the following assumptions:

- Cobalt content is a usual impurity to nickel. In the study we assume that cobalt makes up 2% of nickel weight. The value is adopted on the base of analysis of Co/Ni ratio in stainless steels and assumed to be the upper limit. Though the real content of cobalt may vary within a factor of 10 even in steel. This results in significant uncertainty for great cooling/exposure times, as half decay time of ^{60}Co (the only important radionuclide produced by low energy neutrons in cobalt) is 5.27 year.
- Silver and antimony are usual impurities to copper and lead. There is no data available on concentration of the elements in copper to produce any secure assumptions. For the lead we use concentrations adopted from Chemical Lead UNS L51120 specifications (Pb>99.9%, Ag 0.002 - 0.02%, As+Sb+Sn<0.002%, Bi<0.005%, Cu 0.04 - 0.08%, Fe<0.002%, Zn< 0.001) [10]. Though previous study has shown that such concentrations do not produce significant contribution to activation [11].

3.3.2 ID beam-pipe (VI)

Geometry of VI was adopted from LHCVC1I_0003 drawing. Geometry description of VI is given in Table 5. Materials are beryllium and Aluminum Alloy 5000 Series. Composition of aluminum alloy was adopted from specifications available on [10]: Al 94.8%, Cr - 0.05 - 0.25%, Cu<0.1%, Fe< 0.4%, Mg 4%, Mn 0.4 – 1%, Si<0.4%, Ti<0.15%, Zn<0.25%.

3.3.3 LAr beam-pipe (VA)

Geometry of VA was adopted from LHCVC1A_0001 drawing. Geometry description of VA is given in Table 6. Material is 316L stainless steel. Composition of stainless steel was adopted from UNS S31603 specification [10]: C 0.03%, Cr 16-18%, Fe 62-69 %, Mn 2%, Mo 2-3%, Ni 10-14%, Si 0.75%. Concentration of cobalt was assumed to make up 2% of nickel weight.

Previous study has shown that the dose rate from stainless steel VA will be extremely high – up to several mSv/h [12]. Possible design/material changes are being studied currently to decrease the doses. So the results of VA calculations should be considered as preliminary.

3.3.4 Pixel detector

Geometry and composition of the Pixel detector was taken from inventory of metals spreadsheet produced by Marco Olcese [13]. The geometry and composition for the Pixel detector are given in Table 7 and 8. Concentration of cobalt was assumed to make up 2% of nickel weight.

The inventory is not comprehensive -- non-metallic elements such as carbon and silicon were omitted. Though content of the materials can be recalculated from file prepared by Ivan Bedajnek [14], which gives us approximately 0.6 kg of silicon and 30 kg carbon. Content of silicon is negligible as compared to aluminum – 26 kg in pixel (without type 2 services). Content of carbon is not negligible, but activation in carbon is by order of magnitude less than in aluminum [11] and will hardly produce a noticeable contribution.

3.3.5 SCT

SCT geometry and materials were adopted from the file prepared by Ivan Bedajnek [15]. Geometry and materials of SCT Barrel are given in Tables 9 and 10. Geometry and materials of SCT Forward are given in Tables 11 and 12. Concentration of cobalt was assumed to make up 2% of nickel weight. Major source of Ni (and Co) is nickel-plated Type 2 cables and stainless steel cooling pipes.

The description of SCT Forward is far from being complete. Density of materials in forward modules was assumed to be the same as in barrel modules. A more correct estimation for material inventory is highly desirable.

3.3.7 TRT

TRT geometry and materials were adopted from the file prepared by Ivan Bedajnek [16]. Geometry and materials of SCT Barrel are given in Tables 13 and 14. Concentration of cobalt was assumed to make up 2% of nickel weight. Major source of Ni (and Co) is nickel-plated Type 2 cables and stainless steel cooling pipes.

3.4 Operation scenario

Two scenarios of LHC operation were assumed for the purpose of the study.

- LHC is operated at high luminosity during T=100d.
- LHC is operated for 10 years-- 120 days per year run at high luminosity and the rest of the year LHC is shut down.

In the both cases, activation was studied for cooling time $t= 1d, 3d, 5d, 7d, 15d, 30d,$ and 100 d.

4. Results

4.1 Activation of materials/systems

Results of activation study of Inner Detector systems and VA beam pipe are given in Tables 15-24. The results are expressed in terms of gamma-equivalent induced by low-energy neutrons and high-energy hadrons. Contribution of every individual material is given in percents to subtotal (neutron or hadron activation). The last row is the total gamma-equivalent induced by both neutrons and hadrons. The results are given for T=100 days, 10 years and $t= 1, 3, 5, 7, 15, 30,$ and 100 days after shutdown. Since the volume of information is too large, here we have to limit consideration to cooling time $t= 7$ days.

Activation in VA beam-pipe section is at least by order of magnitude larger than any ID subsystem and needs special consideration. We advisedly exclude it from the further analysis of activation because VA will be removed to allow long access to the Inner Detector. Nevertheless, contribution of VA to dose rate around ID is taken into account (see section 4.2).

Distribution of gamma-equivalent among ID systems is given on Fig. 1. One can see that activation is distributed rather uniformly amongst the systems with the only exception for VI beam-pipe. Activation in every individual system after 10 years of operation is about twice as high than after 100 days (high luminosity was assumed for both operation scenarios, see 3.4).

Despite total gamma-equivalents of all systems is rather similar, it is hardly possible to conclude that all the systems will produce the similar dose rate. In addition to total gamma-equivalent, one should take into account also dimensions of the system, distribution of activity over the volume, and distance to the accessible point. From a very general idea, it is very likely that services will produce greater contribution to the dose rate, as their volume is much smaller.

Contribution of low-energy neutrons and high-energy hadrons to activation of separate ID systems is given on Fig. 2. One can see that activation in every individual system is dominated by hadrons. Contribution of low energy neutrons to total activation depends on particular system and also varies with operational scenario. For example, relative contribution of neutrons grows up with operation time for all the services and either remains the same or decreases for detectors (TRT, SCT, and Pixel).

Contribution of individual materials to total gamma-equivalent induced in the Inner Detector is given on Fig. 3. The most important materials are aluminum, iron, cobalt, nickel, copper, and silver. At that, low-energy neutrons dominate activation of cobalt and silver. It is interesting to note that amount of cobalt is by 2000 times less than copper (Fig. 4), while their contributions are similar. Such a great relative importance of cobalt can be explained by high thermal neutrons activation cross-section and high gamma-ray emission (2.5 MeV per decay) of the activation product ^{60}Co . It is ^{60}Co that will dominate activation

for cooling time exceeding 1 year, as its half decay (5.25 year) is rather great comparing to many others activation products.

It is very likely that lack of information on the exact content of cobalt and silver in the Inner Detector materials is a significant source of uncertainty. In the study we assume that content of cobalt is to correlate with nickel. Concentration of cobalt was assumed to make up 2% of nickel weight (or 2000 ppm in stainless steel). Real content of cobalt in stainless steel is unknown and may vary significantly from the assumption. Content of cobalt in other materials is also unknown. For example, an assumption that cobalt content in copper makes up 200 ppm, will increase the present estimation by factor of 1.5. Content of others important impurities in copper are silver and antimony (of order 2000 ppm each) also need to be studied.

4.2 Induced dose rate

Contribution of different ID systems, VA beam-pipe, and LAr calorimeter to total dose rate around Inner Detector for the long accesses scenario are given in Tables 25-36. The LAr End Cap is shifted by 325 cm along Z-axis. The dose rate are given for the following points:

R= 175 mm, Z= 3340 mm
 R= 400 mm, Z= 3443 mm
 R= 700 mm, Z= 3440 mm
 R= 175 mm, Z= 3800 mm
 R= 400 mm, Z= 3800 mm
 R= 700 mm, Z= 3800 mm

Analysis of the data has shown that the major contributors to the dose rate are VA beam-pipe and LAr End Cap. When the last two are removed, Pixel detector and ID services will determine dose rate.

Additional information on dose rate fields in the long access scenario is given in Addenda as follows.

Addendum 1. Dose rates in the access scenario to the Inner Detector. The following opening layouts are studied:

1. LAr End Cap shifted by 325 cm along Z-axis, all ID systems and VA beam-pipe are in place;
2. LAr End Cap is removed, all ID systems and VA beam-pipe are in place;
3. LAr End Cap and VA beam-pipe are removed, all ID systems are in place;
4. LAr End Cap and VA beam-pipe are removed, Pixel Detector and VI are removed, others ID systems are in place;

Addendum 2. Dose rate fields from dismantled VA beam-pipe.

Addendum 3. Dose rate fields from dismantled Pixel Detector and VI beam-pipe.

Addendum 4. Dose rate fields from LAr Barrel and End Cap calorimeters.

Addendum 5. Dose rate fields in the access scenario to the Inner Detector in a specific case when TRT-C was not originally installed into the ID. The following opening layouts are studied:

1. LAr End Cap shifted by 325 cm along Z-axis; VA beam-pipe and all ID

- structures (including TRT-C) are in place;
2. LAr End Cap shifted by 325 cm along Z-axis; VA beam-pipe and all ID structures (except for TRT-C) are in place;
 3. LAr End Cap is removed; VA beam-pipe and all ID structures (except for TRT-C) are in place;
 4. LAr End Cap and VA beam-pipe are removed; all ID structures (except for TRT-C) are in place;
 5. LAr End Cap, VA beam-pipe, and Pixel Type 2 services are removed; other ID structures (except for TRT-C) are in place;
 6. LAr End Cap, VA beam-pipe are removed, Pixel Type 2 services, Pixel Detector and VI are removed; other ID structures (except for TRT-C) are in place.

Addendum 6. Dose rate fields for the scenario when Pixel and VI, SCT forward, and TRT End Cap with forward services are removed on one side to allow access inside LAr Barrel.

Addendum 7. Dose rate fields around Pixel Detector - four dismantling scenarios are studied.

4.3 Comparison of activation dose rate from SCT Barrel

Doses from SCT Barrel have been estimated by C. Buttar et al in ATL-INDET-2002-013 [17]. Despite the authors have found that SCT Barrel does not pose any serious problems from radiological point of view, the results are valuable for the purpose of comparison with the results of the present study.

Only barrel modules were taken into account in the ATL-INDET-2002-013. The estimation was made at assumption of average beam-luminosity of $5 \times 10^{33} \text{ cm}^{-2} \text{ s}^{-1}$. LHC operation year was defined as 180 days running followed by 185 days of shutdown. Radionuclide production rate for innermost layer of barrel modules was produced with the Monte Carlo particle transport code FLUKA and used for other layers. Gamma and beta dose rate were reported at the distance of 10 cm, 30 cm, and 100 cm from both cylindrical and front surface.

We produced estimation of gamma dose rate from barrel modules taking into account the mentioned assumptions made by C. Buttar et al. The results are given in tables 37-38. Quite a satisfactory agreement (within 20-40%) was found. This gives us some confidence that the data and codes used in the current study are reliable.

5. Conclusions

Major contributors to the dose rate in ID general long access layout are VA beam-pipe and LAr End Cap. Contact gamma dose rate on the surface of VA makes up to 5 mSv/h for cooling time 5 days. Dose rate near LAr End Cap (without VA) makes up few hundreds $\mu\text{Sv/h}$. These will pose serious problems for access to the Inner Detector.

When VA beam-pipe and LAr End Cap are removed, the Pixel detector and ID services will determine dose rate. Gamma dose rate near Pixel PP1 may exceed 100 $\mu\text{Sv/h}$ for cooling time 5 days.

The current study has shown that spallation activation induced by high-energy hadrons produces dominant contribution to gamma dose rate from the Inner Detector. Low-energy neutrons produce a comparable contribution to activation of ID services after a long operation time and cooling time exceeding few weeks.

The most important ID materials contributing to gamma dose rate are aluminum, iron, cobalt, nickel, copper, and silver. Low-energy neutrons dominate activation of cobalt and silver, while high-energy hadrons dominate activation of aluminum, nickel, and copper.

Major sources of silver are SCT modules and electronics. Silver inventory seems to be incomplete and needs further verification, especially for SCT Forward. Another possible source of silver are copper cables, as silver is usual impurity in copper.

Major source of cobalt is stainless steel and other nickel-based materials. Actual content of cobalt is unknown that may result in considerable uncertainty of dose rate estimations from ID services for cooling time exceeding few months. Though, the dose rate from the services after 100 d cooling does not exceed few tens $\mu\text{Sv/h}$.

6. References

1. V.Hedberg, Long access in ATLAS, pages 60-70
http://atlasinfo.cern.ch/Atlas/TCOORD/Activities/CommonSys/Shielding/Activation/access_long_new.pdf
2. Borisov S.E., Kudryavtseva A.V., Leschenko A.V. et al. VVER-500 as a source of induced activity resulting from decommissioning. Atomic Energy, Translated from Russian Original Vol.77, No.4, October, 1994. ISSN 1063-4258, pp.802-807
3. Engovatov I.A., Mashkovich V.P., Orlov Yu.V. et al. Radiation Safety under Decommissioning of Nuclear Reactors of Civilian and Military Purposes/ ISTC Project #465-97
4. Mynat F., Engle W.Jr., Gritzner M. et al. The DOT-III Two-Dimensional Discrete Ordinates Transport Code. ORNL-TM-4280, 1973
5. CASK, 40 groups coupled neutron and gamma-ray cross section data. RSIC data library DLC-23, 1973
6. ~shupe/w1/morev/ on atlas.cern.ch
7. Yu.N.Shubin, V.P.Lunev, A.Yu.Konobeyev, A.I.Ditjuk, "Cross section data library MENDL-2 to study activation and transmutation of materials irradiated by nucleons of intermediate energies", report INDC(CPP)-385 (IAEA, May 1995)
8. A.S.Botvina, A.V.Dementyev, o.N.Smirnova, N.M.Sobolevsky. International Codes and Models Intercomparison for Intermediate Energy Activation Yields. Report of the Institute for Nuclear Research of RAN. Moscow, 1995
9. V.G.Semenov, N.M.Sobolevsky. Approximation of Radionuclides Production Cross-Sections in Proton Induced Nuclear Reactions. Report on ISTC Project #187. Moscow, 1998
10. www.matls.com
11. V.A. Klimanov, E.I. Kulakova, M.N. Morev and V.K. Sakharov, ACTIVATION STUDIES IN THE ATLAS DETECTOR, ISTC Project #1800, Addendum III
http://atlasinfo.cern.ch/Atlas/TCOORD/Activities/CommonSys/Shielding/Activation/antimon_in_pb.pdf
12. DOSES FROM THE LAR BEAMPIPE, Report by M.N. Morev
http://atlasinfo.cern.ch/Atlas/TCOORD/Activities/CommonSys/Shielding/Activation/lar_beampipe.pdf
13. MATERIAL DESCRIPTION OF THE PIXEL DETECTOR, Spreadsheet by M. Olcese
http://atlasinfo.cern.ch/Atlas/TCOORD/Activities/CommonSys/Shielding/Activation/inventory_17_01_2002.xls
14. Report by I. Bedajaneck, The PIXEL detector,
<http://atlasinfo.cern.ch/Atlas/TCOORD/Activities/CommonSys/Shielding/Activation/pixel.doc>
15. Report by I. Bedajaneck, The SCT detector
<http://atlasinfo.cern.ch/Atlas/TCOORD/Activities/CommonSys/Shielding/Activation/sct.doc>
16. Report by I. Bedajaneck, The TRT detector
<http://atlasinfo.cern.ch/Atlas/TCOORD/Activities/CommonSys/Shielding/Activation/trt.doc>
17. Estimating induced-activation of SCT barrel-modules in the ATLAS radiation environment. ATL-INDET-2002-013, Buttar, C; Cindro, V; Dawson, I; Mandic, I; Moraes, A. <http://weplib.cern.ch/cgi-bin/showfull?base=ATLATL&sysnb=0002022>

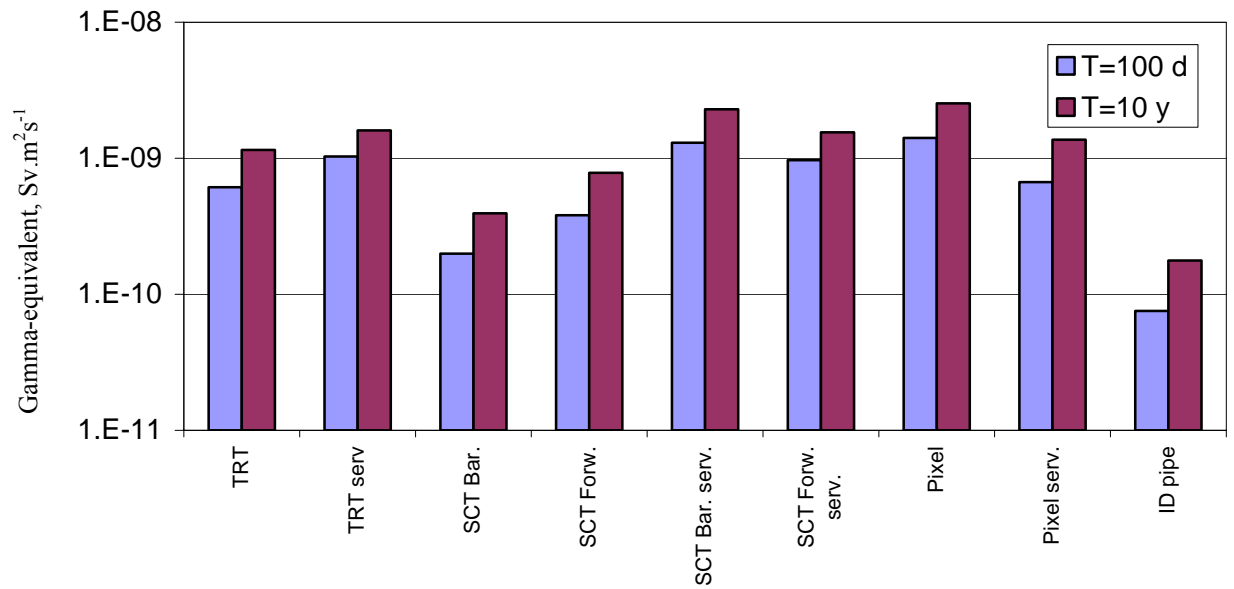

Fig. 1 Gamma-equivalent vs. ID subsystems at cooling time t=7 days

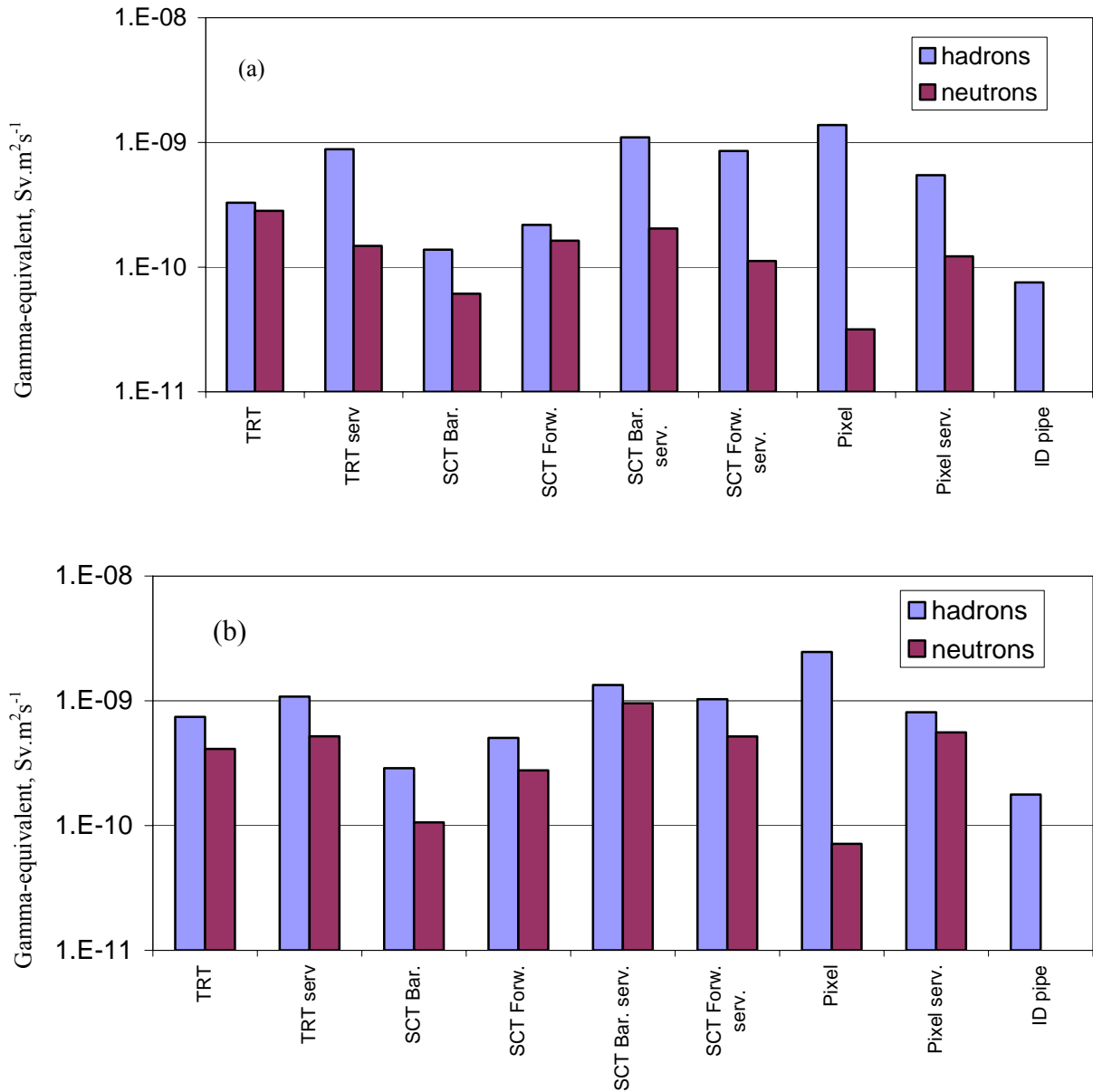

Fig. 2 Gamma-equivalent induced by neutrons/hadrons in ID subsystems for exposure time (a) $T=100$ d and (b) $T=10$ y, cooling time $t=7$ days

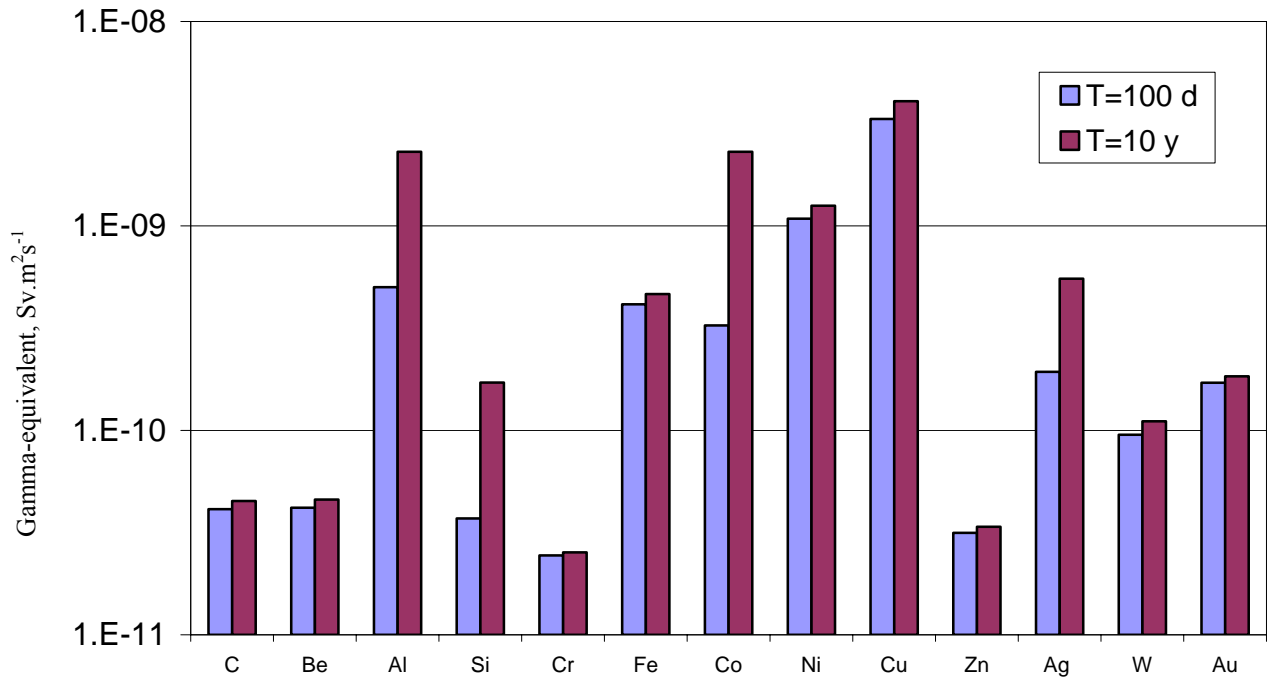

Fig. 3 Gamma-equivalent vs. ID materials cooling time t=7 days

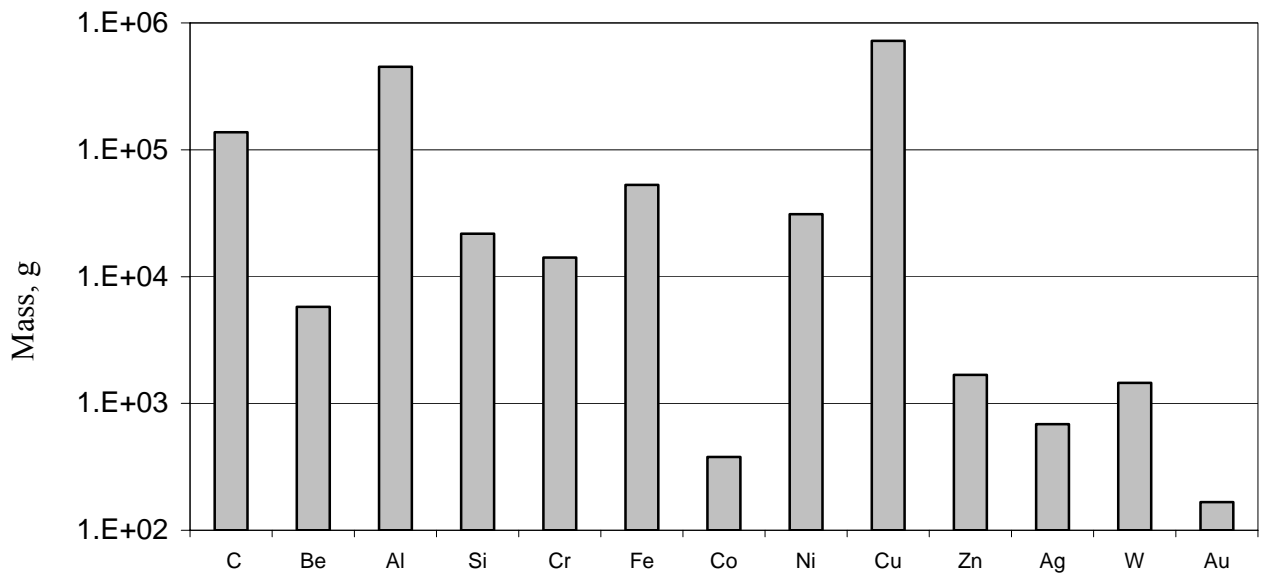

Fig. 4 Material break down of Inner Detector

Table 1

Geometry description of the LAr Barrel Calorimeter

ELEMENT	Element ID	ELEMENT GEOMETRY (ring/disk)				Material
		Z1[cm]	Z2[cm]	R1[cm]	R2[cm]	
Barrel inner warm wall	1	0	304	115	116	ALUMINUM
Barrel inner cold wall section 1	2	0	7.5	134.1	138.5	ALUMINUM
Barrel inner cold wall section 2	3	7.5	40	134.9	138.5	ALUMINUM
Barrel inner cold wall section 3	4	40	112	135.8	138.5	ALUMINUM
Barrel inner cold wall section 4	5	112	195	136.4	138.5	ALUMINUM
Barrel inner cold wall section 5	6	195	240	136.8	138.5	ALUMINUM
Barrel inner cold wall section 6	7	240	302.3	136.8	138.5	ALUMINUM
Barrel inner cold corner section 1	8	302.3	310.1	136.5	138.5	ALUMINUM
Barrel inner cold corner section 2	9	310.1	325.3	137.1	138.5	ALUMINUM
Barrel inner cold corner section 3	10	325.3	326.7	137.1	156.55	ALUMINUM
Barrel cold wall end inner section	11	326.7	328.7	156.55	185	ALUMINUM
Barrel cold wall end outer section	12	326.7	330.2	185	219	ALUMINUM
Solenoid	13	0	265	123.1	127.1	COILMIX
Preshower detector	14	0	300.8	140.5	143.6	PRESHOWER
Liquid argon in front of preshower	15	0	300.8	138.5	140.5	LIQ_ARGON
Middle accordion volume	16	0	134.1	151	197.9	LAr EM 1.8 PB
North accordion volume wedge before eta=.8	17	134.1	145	157.2	197.9	LAr EM 1.8 PB
-----	18	145	155	168.9	197.9	LAr EM 1.8 PB
-----	19	155	165	180.1	197.9	LAr EM 1.8 PB
-----	20	165	175.8	191.5	197.9	LAr EM 1.8 PB
North accordion volume wedge after eta=.8	21	134.1	145	151	157.2	LAR EM 1.2 PB
-----	22	145	155	151	168.9	LAR EM 1.2 PB
-----	23	155	165	151	180.1	LAR EM 1.2 PB
-----	24	165	175.8	151	191.5	LAR EM 1.2 PB
North accordion volume cylinder after eta=.8	25	175.8	300.8	151	197.9	LAR EM 1.2 PB
North accordion end volume (tapered)	26	300.8	315	151	197.9	LAR EM 1.2 PB
Accordion front materials	27	0	300.8	144	151	EM IN TAB
Accordion exit materials	28	0	315	197.9	214	EM OUT TAB
Barrel outer cold wall	29	0	299.6	214	217	ALUMINUM
Barrel outer cold wall vertical	30	292.6	299.6	217	228	ALUMINUM
Barrel cold wall flange	31	299.6	322.7	221.5	226.5	ALUMINUM
Barrel cold wall flange connector	32	322.7	331.7	219	228	ALUMINUM
Liquid at end of EM accordion	33	315	326.7	156.55	219	LIQ ARGON
Barrel outer warm wall	34	0	285	222	225	ALUMINUM
Barrel outer warm vertical	35	285	290	222	271.1	ALUMINUM
Barrel outer warm horizontal flange	36	285	339	271.1	277.5	ALUMINUM
Barrel warm flange connector 1	37	334	339	251.6	271.1	ALUMINUM
Barrel warm flange connector 2	38	339	340.5	251.6	269	ALUMINUM
End warm vertical bulkhead	39	336.7	340.5	185	251.6	ALUMINUM
-----	40	338.5	340.5	142	185	ALUMINUM
-----	41	339.3	340.5	122.02	142	ALUMINUM
Barrel warm front corner	42	315	340.5	120.8	122.02	ALUMINUM
Barrel warm front corner	43	312.5	315	115	117.1	ALUMINUM
Barrel warm front corner	44	304	316	117.3	120.8	ALUMINUM
Barrel warm front corner	45	304	306.5	115	117.3	ALUMINUM

Table 2

Composition of LAr Barrel materials

ELEMENT	MATERIAL							
	ALUM	COILMIX	PRE SHOWER	LIQ ARGON	LAr EM 1.8 PB	LAr EM 1.2 PB	EM IN TAB	EM OUT TAB
H		1.02E-03	6.96E-03		1.81E-03	2.98E-03	6.24E-03	3.71E-03
C			3.06E-03		2.82E-03	1.65E-02		
O		4.80E-03	7.91E-03		8.75E-04	9.60E-04	2.93E-02	1.75E-02
Si	2.45E-04	1.39E-03	2.14E-03		2.54E-04	2.78E-04	8.51E-03	5.06E-03
Al	6.02E-02	3.15E-02						
Ar			6.49E-03	2.11E-02	1.25E-02	1.37E-02	3.35E-03	8.96E-03
Ca		6.91E-04	1.06E-03		1.26E-04	1.38E-04	4.22E-03	2.51E-03
Ti	5.37E-05							
Cr	6.60E-05				1.70E-03	2.20E-03		4.25E-03
Mn	3.12E-04				1.79E-04	2.31E-04		4.47E-04
Fe	1.23E-04				6.24E-03	8.08E-03	1.17E-07	1.56E-02
Ni					8.78E-04	1.14E-03		2.20E-03
Co					1.76E-05	2.27E-05		4.39E-05
Cu	2.70E-05	8.09E-03	5.11E-03		2.29E-05	1.68E-05	4.10E-06	2.03E-06
Zn	6.56E-05				2.79E-07	2.04E-07	4.98E-08	2.47E-08
As					2.43E-07	1.78E-07	4.35E-08	2.16E-08
Ag					3.38E-06	2.47E-06	6.04E-07	3.00E-07
Sn					1.53E-07	1.12E-07	2.74E-08	1.36E-08
Sb					1.50E-07	1.09E-07	2.68E-08	1.33E-08
Pb					8.78E-03	6.43E-03	1.57E-03	7.79E-04
Bi					4.36E-07	3.19E-07	7.79E-08	3.87E-08

Table 3

Geometry description of the LAr End Cap Calorimeter

ELEMENT	Element ID	ELEMENT GEOMETRY (ring/disk)				Material
		Z1[cm]	Z2[cm]	R1[cm]	R2[cm]	
EC EM inner volume	1	367.7	385	30.7	47	EC EMI
----	2	385	402	32.1	56.2	EC EMI
----	3	402	419.5	33.5	64.9	EC EMI
EC EM outer volume	4	367.7	385	47	208.9	EC EMO
----	5	385	402	56.2	208.9	EC EMO
----	6	402	419.5	64.9	208.9	EC EMO
G10 support bars inside EC EM	7	367.7	385	28.9	30.7	G10
----	8	385	402	30.3	32.1	G10
----	9	402	419.5	31.7	33.5	G10
EC HEC1A volume north	10	426.5	456.7	37	208.9	EC HAD1
EC HEC1B volume north	11	456.7	510.9	47.3	208.9	EC HAD2
EC HEC2 volume north	12	512	610.8	47.3	208.9	EC HAD3
EC front bumper block	13	374.7	379.2	18.5	23.8	G10
EC cylindrical support tube	14	466.85	635	45.7	46.5	ALUMINUM
Liquid argon layer outside the support tube	15	466.85	635	46.5	47.3	LIQ ARGON
EC support tube back flange at rear of 5	16	635	644.5	46.5	49.5	ALUMINUM
EC Plug 1 - main copper absorber at back of EC	17	627.5	644.5	59	193.5	PLUG BRASS
EC Plug 2 – small plug at back of HEC2 near beam-line	18	610.8	623	47.5	59.5	PLUG BRASS
Cable fill in pocket at back of cylindrical transition	19	623	644.5	49.5	59	LAR CABLES
Liquid argon and cables in front of EMEC	20	361.2	367.7	30	208.9	LAR CABLES
Liquid argon and cables outside the hadronic modules	21	361.2	644.5	208.9	212.4	LAR CABLES
Liquid argon and cables at rear of HEC2	22	610.8	627.5	69	208.9	LAR CABLES
Liquid argon and cables at rear of EMEC	23	419.5	426.5	37	208.9	LAR CABLES
Liquid argon and cables at rear of first hadronic compartment	24	510.9	512	47.3	208.9	LAR CABLES
EC front warm wall	25	350	351.5	18.2	226	ALUMINUM
Poly around beam pipe at front of EC (plugging FCAL hole)	26	350	362	6	18.2	POLYLITH
EC flange block at front of 2X (2Y)	27	351.5	374.7	18.2	19.7	ALUMINUM
EC warm wall north nearer I.P. (2X)	28	374.7	454	18.1	18.5	ALUMINUM
Connecting washer, 2X to 2 (2Z)	29	454	455	5.1	18.5	ALUMINUM
EC inner warm wall	30	454	662.5	4.8	5.1	ALUMINUM
EC outer warm wall	31	351.5	616	223	226	ALUMINUM
EC outer warm wall vertical	32	616	619	223	240.5	ALUMINUM
EC outer warm wall horizontal flange	33	616	662.5	240.5	247.5	ALUMINUM

Table 3 (continuation)
Geometry description of the LAr End Cap Calorimeter

ELEMENT	Element ID	ELEMENT GEOMETRY (ring/disk)				Material
		Z1[cm]	Z2[cm]	R1[cm]	R2[cm]	
EC rear warm wall	34	662.5	668.5	4.8	247.5	ALUMINUM
EC front cold wall	35	354.7	361.2	22.8	217.5	ALUMINUM
EC inner cold wall north	36	464.35	644.5	6.1	6.7	ALUMINUM
EC inner cold wall north front near I.P.	37	374.7	461.85	26.8	27.8	ALUMINUM
EC flange	38	361.2	374.7	22.8	27.8	ALUMINUM
EC outer cold wall	39	361.2	619	214	217.5	ALUMINUM
EC outer back corner cold wall	40	619	644.5	214	224.5	ALUMINUM
EC back cold wall	41	644.5	658.3	6.1	224.5	ALUMINUM
EC inner back cold wall	42	658.3	662.5	9.5	13.1	ALUMINUM
EC back cold wall thin section near beam-ine	43	658.3	659	6.1	9.5	ALUMINUM
FC EM volume north	44	466.85	532	7.2	45	FC EM
Cold wall in front of EM	45	461.85	464.35	6.1	45.7	ALUMINUM
Liquid argon and cables outside FCAL	46	480.5	644.5	45	45.7	LAR CABLES
Liquid argon and cables behind EM	47	532	532.5	7.9	45	LAR CABLES
----	48	532.5	577.65	8.9	44	FC HAD1
----	49	532.5	577.65	7.9	8.9	COPPER
----	50	532.5	577.65	44	45	COPPER
Liquid argon and cables at back of FC H1	51	577.65	580.15	8.6	45	LAR CABLES
----	52	580.15	604.7	9.6	44	FC HAD1
----	53	580.15	577.65	8.6	9.6	COPPER
----	54	580.15	577.65	44	45	COPPER
Liquid argon and cables at back of FC H2	55	604.7	607.2	9.5	45	LAR CABLES
Plug3	56	607.2	639.6	9.5	44.7	PLUG BRASS
Notch	57	639.6	644.5	14.5	44.7	PLUG BRASS
Services in gap between electronics crates and fingers	58	612	667.5	331.3	388	GAP MAT

Table 4

Composition of LAr End Cap calorimeter

ELEMENT	MATERIAL														
	EC EMI	EC EMO	EC HAD1	EC HAD2	EC HAD3	LAR CABLES	PLUG BRASS	FC EM	FC HAD1	POLY LITH	GAP MIX	G10	ALUM	LIQUID ARGON	COPPER
H	2.8E-02	3.2E-02				6.5E-04				7.7E-02	3.6E-02	1.5E-03			
Li										2.2E-03					
C	2.0E-03	2.3E-03								3.7E-02	2.1E-02				
O						6.2E-03					3.5E-03	1.1E-02			
F										2.2E-03					
Al													6.0E-02		
Si						1.3E-03						5.7E-02			
Ar	1.3E-02	1.3E-02	5.1E-03	5.4E-03	3.0E-03	1.8E-02		3.1E-04	3.3E-03					2.1E-02	
Ca						8.9E-04			7.5E-04			4.0E-02			
Ti													5.4E-05		
Cr											6.3E-03		6.6E-05		
Mn											6.6E-04		3.1E-04		
Fe	4.6E-03	5.3E-03									2.3E-02		1.2E-04		
Ni									1.4E-03		3.2E-03				
Co	1.2E-05	1.4E-05							2.9E-05		6.2E-05				
Zn	3.2E-07	2.8E-07					1.6E-03						6.6E-05		
Cu	2.6E-05	2.3E-05	6.4E-02	6.3E-02	7.3E-02		7.2E-02	7.4E-02	1.1E-02		1.3E-02		2.7E-05		8.5E-02
As	2.8E-07	2.5E-07													
Sb	1.7E-07	1.5E-07													
Sn	1.8E-07	1.5E-07						3.1E-03							
Ag	3.9E-06	3.4E-06													
W									4.2E-02						
Pb	1.0E-02	8.9E-03						7.5E-04							

Table 5

Material zones of the VI beam pipe section (right half)

##	Z _{min} , cm	Z _{max} , cm	R _{min} , cm	R _{max} , cm	Material	Mass, kg	Comment
1	0	343.9	3.38	3.46	Be	1.093	Outer tube
2	0	355	2.9	2.98	Be	0.970	Inner tube
3	355	365	2.9	2.98	Al	0.040	Inner tube
4	350.5	357.5	3.38	3.46	Al	0.032	Outer tube
5	343.9	350.5	3.38	3.46	Al	0.031	Bellows ^(*)
6	363.6	365	2.98	4.3	Al	0.114	Flange

^(*) - under study now – assumed as tube

Table 6

Material zones of the VA beam pipe section

##	Z _{min} , cm	Z _{max} , cm	R _{min} , cm	R _{max} , cm	Material	Mass, kg	Comment
1	365	366.4	2.9	4.3	SS 316L	0.346	Flange
2	366.4	387.6	2.9	2.98	SS 316L	0.063	Tube
3	373.2	373.28	2.98	8.3	SS 316L	0.075	Pump wall
4	373.28	378.8	8.23	8.3	SS 316L	0.206	Pump wall
5	378.8	378.88	2.98	8.3	SS 316L	0.262	Pump wall
6	374.8	378	4.5	4.7	SS 316L	0.317	Pump electrode
7	374.8	378	6.8	7	SS 316L	0.224	Pump electrode
8	387.6	395.8	2.9	3.04	SS 316L	0.472	Bellows
9	395.8	415.1	2.9	2.98	SS 316L	0.045	Tube
10	415.1	423.3	2.9	3.04	SS 316L	0.472	Bellows
11	423.3	855	2.9	2.98	SS 316L	0.045	Tube
12	855	863.2	2.9	3.04	SS 316L	0.317	Bellows
13	863.2	870	2.9	2.98	SS 316L	0.262	Tube
14	868.6	870	2.98	4.3	SS 316L	0.206	Flange
15	428.9	849	3.92	4	SS 316L	0.075	Tube

Table 7

Geometry description of the Pixel detector

ELEMENT	Element ID	ELEMENT GEOMETRY (ring/disk)			
		Z1[cm]	Z2[cm]	R1[cm]	R2[cm]
B-layer	1	0	40	4.55	7.4
Layer 1	2	0	40	8.3	11.1
Layer 2	3	0	40	11.7	14.4
Disk 1	4	49	50	8.5	14.8
Disk 2	5	57.5	58.5	8.5	14.8
Disk 3	6	64.5	65.5	8.5	14.8
B-layer end	7	40	44.2	4.55	7.4
Layer 1 end	8	40	44.2	8.3	11.1
Layer 2 end	9	40	44.2	11.7	14.4
Disk 1 cooling connections	10	49	50	14.8	17
Disk 2 cooling connections	11	57.5	58.5	14.8	17
Disk 3 cooling connections	12	64.5	65.5	14.8	17
Barrel radial services	13	44.2	48.4	4.55	17
Barrel/disk type 0 services along frame	14	44.2	70	17	21.5
Outer frame connections	15	42	44.2	20.5	21.5
PP0	16	70	107	17	21.5
Type 1 services	17	107	328	17	21.5
PP1 zone 1	18.1	328	333.5	20.5	22.5
PP1 zone 2	18.2	328	333.5	11.5	20.5
PP1 zone 3	18.3	328	333.5	7.5	11.5
PP1 zone 4	18.4	333.5	334	7.5	22.5
PP1 zone 5	18.5	334	335.5	20.5	40
PP1 zone 6	18.6	334	335.5	11.5	20.5
PP1 zone 7	18.7	335.5	341.5	11.5	40
PP1 zone 8	18.8	341.5	344.3	11.5	40
PP1 zone 9	18.9	334	344.3	7.5	11.5
PP1 zone 10 (cables)	18.10	310.2	312.2	15	40
PP1 zone 11 (cables)	18.11	310.2	321	40	42
PP1 zone 12 (connectors)	18.12	321	327	40	43
Central PST	19	0	80	22.7	22.8
Pixel to PST to SCT fixations	20	75	80	22.8	28.5
Forward PST	21	80	333.5	22.7	22.8
Type 2 services	22	342	344.3	40	280

Table 8

Composition of the Pixel detector

Element ID	MATERIAL																	
	Al	Cu	Ni	Co	Sn	Pb	Ag	Au	Fe	Cr	In	Ru	Pd	Mg	Mo	Ti	Mn	Zn
1	425.0	109.7	8.51	0.17	6.87	6.36	15.82	0.23	37.63	15.26	0.04	0.06	0.02	1.00	1.81	9.15		
2	587.4	187.4	10.51	0.21	11.87	10.98	27.32	0.40	39.08	15.91	0.07	0.10	0.04	1.74	1.88	15.80		
3	803.8	256.8	13.27	0.27	16.24	15.03	37.38	0.54	46.53	18.97	0.09	0.14	0.05	2.37	2.23	21.63		
4	107.6	17.3	0.41	0.01	1.15	1.07	2.65	0.04			0.01	0.01				1.54		
5	107.6	17.3	0.41	0.01	1.15	1.07	2.65	0.04			0.01	0.01				1.54		
6	107.6	17.3	0.41	0.01	1.15	1.07	2.65	0.04			0.01	0.01				1.54		
7	3.5	14.7	17.13	0.34	0.01				15.31	6.18	0.70				0.74			
8	6.0	25.3	29.69	0.59	0.02				27.09	10.93	1.22				1.31			
9	8.2	34.6	39.02	0.78	0.02				27.09	10.93	1.66				1.31			
10	12.4	1.6	1.60	0.03							0.13							
11	12.4	1.6	1.60	0.03							0.13							
12	12.4	1.6	1.60	0.03							0.13							
13	930.4	20.3	5.44	0.11						0.08			0.49					
14	4150.5	80.0	21.89	0.44						0.26	0.38			1.51		0.08	0.39	0.15
15	14.5	0.0	8.60	0.17					53.32	21.50					2.58			
16	619.5	631.8			31.83	16.66		0.02		0.85				4.12		1.07	5.28	2.03
17	11171.	380.3								6.60				31.96		8.27	40.94	15.74
18.1	28.9	51.6	8.60	0.17	11.62	6.92		0.02	53.32	21.72					2.58			
18.2	743.5	37.5								1.01				4.85		1.26	6.24	2.36
18.3	14.4	51.6			11.62	6.92		0.02		0.22								
18.4	729.1	63.3			2.49	1.48				1.08				4.85		1.26	6.24	2.36
18.5	0.0	189.1			41.81	23.27		0.12		0.79								
18.6	1458.2	74.9								2.01				9.69		2.52	1.24	4.78
18.7	2232.7	114.7								3.09				14.84		3.83	19.02	7.28
18.8	0.0	576.1			35.60	19.64		0.10		0.65								
18.9	0.0	140.3			11.62	6.47		0.02		0.14								
18.10		7000.0																
18.11		4500.0																
18.12	20000.0																	
19	580.5	0.0																
20	7.3	0.0	4.30	0.09					26.66	10.75					1.29			
21	1103.0	0.0																
22	61256.	71111.	7864.5	157.29						4.99				30.99				

Table 9

Geometry description of the SCT Barrel Detector

ELEMENT	Element ID	ELEMENT GEOMETRY (ring/disk)			
		Z1[cm]	Z2[cm]	R1[cm]	R2[cm]
Thermal shield 1	1	0	75.4	54.83	54.9
Thermal shield 2	2	75.4	79	54	54.9
Thermal shield 3	3	72.4	75.4	54	54.83
Thermal shield 4	4	23.3	26.3	54	54.83
Thermal shield 5	5	78.82	79	25	54
Thermal shield 6	6	0	77	25	25.0175
Barrel interlink	7	78.7	78.82	26	50
SCT barrel 3 + Support cylinder	8	0	78.294	27.8	28.4
Close out at the end of barrel	9	78.294	78.32	27.8	28.4
End flange	10	78.32	78.7	25.8	28.4
SCT barrel 4 +Support cylinder	11	0	78.294	34.9	35.5
Close out at the end of barrel	12	78.294	78.32	34.9	35.5
End flange	13	78.32	78.7	32.5	35.5
SCT barrel 5 +Support cylinder	14	0	78.294	42.1	42.7
Close out at the end of barrel	15	78.294	78.32	42.1	42.7
End flange	16	78.32	78.7	39.5	42.7
SCT barrel 6 +Support cylinder	17	0	78.294	49.201	49.801
Close out at the end of barrel	18	78.294	78.32	49.2	49.8
End flange	19	78.32	78.7	46.6	49.8
SCT pipes	20	30.841	50	78	78.5
Cables and cooling pipes from barrels to PPB1	21	78	79.84	50	114
Cables and cooling pipes from PPB1 to PPB2	22	79.84	343	112.3	115

Table 10

SCT Barrel Detector composition

Element ID	MATERIAL															
	H	Be	B	C	N	O	F	Al	Si	Ni	Co	Cu	Ag	Sn	Au	Pb
1	2.05			1448.15	5.75	16.47	336.76	1773.36								
2				538.16			172.63	169.99								
3	75.37			452.19												
4	75.37			452.19												
5				666.79				69.99								
6	4.47			118.86	12.54	35.90		245.15								
7	28.59			760.96	80.27	229.83										
8	18.05	114.625	52.99	2726.9	157.63	385.15	665.7	560.45	2259.84	7.68	0.155	493.825	19.2	11.71	2.11	18.625
9										7.39		17.25				
10	6.99			186.17	19.64	56.23										
11	22.56	143.28	66.24	3410.84	197.04	481.44	832.13	700.55	2824.8	9.6	0.19	617.28	24	14.64	2.64	23.28
12										9.26		21.60				
13	10.13			269.51	28.43	81.40										
14	27.07	171.935	79.49	4097.73	236.45	577.73	998.555	840.65	3389.76	11.52	0.23	740.735	28.8	17.57	3.17	27.935
15										11.15		26.02				
16	13.06			347.51	36.66	104.95										
17	31.585	200.59	92.735	4781.67	275.855	674.015	1164.98	980.75	3954.72	13.44	0.27	864.19	33.6	20.495	3.695	32.59
18										13.02		30.38				
19	15.31			407.54	42.99	123.09	509.39	2258.5		40.82		95.26				
20										25.7	0.51	59.9				
21								2800.0		600	12	1200				
22										10011.8	200.2	264856.				

Table 11

Geometry description of the SCT Forward Detector

ELEMENT	Element ID	ELEMENT GEOMETRY (ring/disk)			
		Z1[cm]	Z2[cm]	R1[cm]	R2[cm]
Thermal_shield_1	1	81.10	81.20	25.10	61.00
Thermal_shield_2	2	82.00	82.02	50.00	59.00
Thermal_shield_3	3	82.05	84.00	58.20	59.90
Thermal_shield_4	4	82.00	82.50	59.90	61.00
Thermal_shield_5	5	82.50	273.30	59.90	61.00
Thermal_shield_6	6	82.50	273.30	61.00	61.09
Thermal_shield_7	7	274.90	274.92	25.80	57.20
Thermal_shield_8	8	274.92	275.72	25.80	57.20
Thermal_shield_9	9	278.60	278.70	25.80	61.50
Thermal_shield_10	10	275.80	278.50	25.80	29.15
Thermal_shield_11	11	81.30	278.70	25.55	25.80
Thermal_shield_12	12	81.30	81.85	25.80	30.50
SCT_disk_1	13	82.85	86.85	26.70	56.70
SCT_disk_2	14	91.20	95.20	26.70	56.70
SCT_disk_3	15	106.20	110.20	26.70	56.70
SCT_disk_4	16	124.00	128.00	26.70	56.70
SCT_disk_5	17	135.50	139.50	26.70	56.70
SCT_disk_6	18	172.50	176.50	26.70	56.70
SCT_disk_7	19	205.00	209.00	26.70	56.70
SCT_disk_8	20	244.00	248.00	37.40	56.70
SCT_disk_9	21	270.50	274.50	37.40	56.70
Cooling_pipe_1	22	84.85	275.70	58.39	58.39
Cooling_pipe_2	23	93.20	275.70	58.39	58.40
Cooling_pipe_3	24	108.20	275.70	58.40	58.41
Cooling_pipe_4	25	126.00	275.70	58.41	58.42
Cooling_pipe_5	26	137.50	275.70	58.42	58.42
Cooling_pipe_6	27	174.50	275.70	58.42	58.43
Cooling_pipe_7	28	207.00	275.70	58.43	58.44
Cooling_pipe_8	29	246.00	275.70	58.44	58.44
Cooling_pipe_9	30	272.50	275.70	58.44	58.44
Power_tape_1	31	84.85	275.70	59.85	59.85
Power_tape_2	32	93.20	275.70	59.85	59.86
Power_tape_3	33	108.20	275.70	59.86	59.87
Power_tape_4	34	126.00	275.70	59.87	59.88
Power_tape_5	35	137.50	275.70	59.88	59.88
Power_tape_6	36	174.50	275.70	59.88	59.89
Power_tape_7	37	207.00	275.70	59.89	59.89
Power_tape_8	38	246.00	275.70	59.89	59.90
Power_tape_9	39	272.50	275.70	59.90	59.90
Patch_panel_1	40	83.25	84.45	55.70	56.70
Patch_panel_2	41	92.00	92.80	55.70	56.70
Patch_panel_3	42	106.60	107.80	55.70	56.70
Patch_panel_4	43	124.40	125.60	55.70	56.70
Patch_panel_5	44	135.90	137.10	55.70	56.70
Patch_panel_6	45	172.90	174.10	55.70	56.70
Patch_panel_7	46	205.80	206.60	55.70	56.70
Patch_panel_8	47	244.80	245.60	55.70	56.70
Patch_panel_9	48	271.60	272.10	55.70	56.70
Type II cables	49	273.00	350.00	114.00	115.00
Type II cables	50	272.50	273.00	55.90	114.00

Table 12

SCT Forward Detector composition

Element ID	MATERIAL														
	H	Be	B	C	N	O	Al	Si	Ni	Co	Cu	Ag	Sn	Au	Pb
1							924.39								
2							166.76								
3				1232.45											
4				209.33											
5				79878.9											
6							1689.								
7							509.5								
8				6563.45											
9							2649.9								
10				2174.83											
11				11088.6											
12				636.82											
13	12.49	226.9	36.77	1448.49	61.80	87.17	77.00	583.23	4.90	0.10	294.10	20	9.60	2.16	14.30
14	17.76	401.3	65.04	1905.72	109.34	154.21	136.24	1031.88	8.67	0.17	520.33	35	16.99	3.81	25.31
15	17.76	401.3	65.04	1905.72	109.34	154.21	136.24	1031.88	8.67	0.17	520.33	35	16.99	3.81	25.31
16	17.76	401.3	65.04	1905.72	109.34	154.21	136.24	1031.88	8.67	0.17	520.33	35	16.99	3.81	25.31
17	17.76	401.3	65.04	1905.72	109.34	154.21	136.24	1031.88	8.67	0.17	520.33	35	16.99	3.81	25.31
18	17.76	401.3	65.04	1905.72	109.34	154.21	136.24	1031.88	8.67	0.17	520.33	35	16.99	3.81	25.31
19	12.49	226.9	36.77	1448.49	61.80	87.17	77.00	583.23	4.90	0.10	294.10	20	9.60	2.16	14.30
20	12.62	401.4	65.05	1593.24	109.34	154.22	136.24	1031.88	8.67	0.17	520.33	35	16.99	3.81	25.31
21	7.14	226.9	36.77	1135.98	61.80	87.17	77.00	583.23	4.90	0.10	294.10	20	9.60	2.16	14.30
22							285.90								
23							410.07								
24							376.42								
25							336.46								

Table 12 (continuation)

Element ID	MATERIAL BREAKDOWN														
	H	Be	B	C	N	O	Al	Si	Ni	Co	Cu	Ag	Sn	Au	Pb
26							310.65								
27							227.51								
28							102.99								
29							44.53								
30							2.40								
31							959.25								
32							1299.91								
33							1193.21								
34							1066.54								
35							984.72								
36							721.17								
37							345.53								
38							149.39								
39							9.09								
40							1146.43								
41							764.28								
42							1146.43								
43							1146.43								
44							1146.43								
45							1146.43								
46							764.28								
47							764.28		2787.2	55.7	73240.				
48							477.68		2103.1	42.1	55263.				

Table 13

Geometry description of the TRT detector

ELEMENT	Element ID	ELEMENT GEOMETRY (ring/disk)			
		Z1[cm]	Z2[cm]	R1[cm]	R2[cm]
Barrel TRT	1	0	71.2	55.8	107.3
TRT A	2	82.6	170.7	62	107.6
TRT B	3	172	271.6	62	107.6
TRT C	4	281.6	340.6	46	103.4
Barrel Module 1 services	5	77.2	78.5	60	115
Barrel Module 2 services	6	78.5	80	75	115
Barrel Module 3 services	7	80	81	90	115
Wheels A services	8	124	340	113	114
Wheels B services	9	225	340	112	113
Wheels C services	10	338	340	105	112
Barrel electronics	11	71.2	77.2	56	107
EC electronics	12	82.6	338	107.6	108.6
Squirrel cage	13	82.6	338	108.6	109.2
Module 1,2,3 services	14	81	340	114	115
TRT services	15	340	345	109.2	317

Table 14

TRT composition

Element ID	MATERIAL BREAKDOWN															
	Cu	Al	Si	Fe	Mn	Cr	Ni	Co	Zn	Sn	Pb	Au	Ag	Ba	Ti	W
1												23.75				339.32
2												27.06				386.58
3												30.59				437.04
4												20.09				287.07
5	1532.23	325.90		1442.70	41.22	370.98	206.10	4.1								
6	2188.65	327.43		1422.99	40.66	365.91	203.28	4.0								
7	1765.40	241.74		1186.39	33.90	305.07	169.48	3.38								
8	41784.8	6381.80		5432.90	155.23	1397.03	776.13	15.5								
9	15720.1	2559.69		3599.70	102.85	925.64	514.24	10.2								
10	2108.27	487.11		585.99	16.74	150.68	83.71	1.6								
11	5497.73	6686.5	1458.10	1285.48	36.73	330.55	183.64	3.7	938.95	13.05	13.05	10.92	262.72	270.07	94.31	
12	15000.					77.50		0	35.00	2215.0	1476.5	12.50				
13	270.00	268000.		1075.00		670.0		0	670.00							
14	36037.0	5213.91		11746.1	335.60	3020.41	1678.01	33.6								
15	113634.	19902.8		24893.3	711.24	6401.15	3556.19	71.								

Table 15

Gamma-equivalents in TRT volume by material

		T=100 d							T=10 y						
Hadrons	Material	t= 1 d	t= 3 d	t= 5 d	t= 7 d	t= 15 d	t= 30 d	t= 100 d	t= 1 d	t= 3 d	t= 5 d	t= 7 d	t= 15 d	t= 30 d	t= 100 d
		Al	50.4	31.2	29.2	31.2	39.0	48.3	66.5	63.3	59.9	62.1	64.6	71.0	77.0
	Si	0.2	0.2	0.2	0.2	0.3	0.3	0.5	0.3	0.4	0.4	0.5	0.5	0.5	0.6
	Ti	0.1	0.2	0.2	0.2	0.2	0.2	0.1	0.1	0.1	0.1	0.1	0.1	0.1	0.0
	Mn	1.1	1.9	2.0	2.0	1.8	1.5	1.2	0.9	1.2	1.3	1.2	1.0	0.9	0.7
	Fe	5.0	8.0	8.3	7.7	5.6	3.7	2.2	3.7	4.5	4.2	3.8	2.6	1.7	1.0
	Ni	0.9	1.5	1.7	1.7	1.8	1.9	1.5	0.7	0.9	0.9	0.9	0.8	0.8	0.5
	Cu	14.3	23.9	27.0	27.9	29.0	28.6	20.8	11.4	14.9	15.3	15.2	14.2	12.7	8.4
	W	27.9	33.0	31.4	28.9	22.4	15.4	7.2	19.6	18.1	15.7	13.8	9.7	6.3	2.9
	Subtotal	8.95E-10	4.51E-10	3.65E-10	3.29E-10	2.60E-10	2.07E-10	1.42E-10	1.31E-09	8.66E-10	7.79E-10	7.43E-10	6.70E-10	6.11E-10	5.20E-10
Neutrons	Al	5.0	1.5	0.3	0.0	0.0	0.0	0.0	4.7	1.3	0.2	0.0	0.0	0.0	0.0
	Cr	0.2	0.5	0.9	1.2	1.8	1.5	0.3	0.2	0.5	0.7	0.9	1.0	0.8	0.2
	Fe	0.1	0.3	0.5	0.7	1.2	1.2	0.6	0.1	0.3	0.5	0.6	0.8	0.8	0.5
	Co	0.2	0.5	0.8	1.2	2.2	2.6	3.1	1.1	2.8	4.4	5.7	8.4	9.3	11.0
	Ni	0.1	0.2	0.3	0.5	0.8	0.8	0.5	0.1	0.2	0.3	0.4	0.5	0.5	0.3
	Cu	27.6	5.6	0.7	0.1	0.0	0.0	0.0	25.9	4.7	0.5	0.1	0.0	0.0	0.0
	Zn	1.0	2.6	4.5	6.4	11.6	13.2	13.5	1.7	4.0	6.2	8.0	11.5	12.3	12.3
	Ag	5.6	15.5	26.7	37.8	68.6	78.4	80.4	9.7	24.0	37.2	47.9	69.4	74.3	74.2
	Sn	0.3	0.8	1.3	1.7	2.4	2.0	1.4	0.4	0.9	1.3	1.6	2.0	1.8	1.5
	W	27.3	18.8	8.1	2.9	0.0	0.0	0.0	25.6	15.9	6.2	2.0	0.0	0.0	0.0
	Au	32.5	53.8	55.8	47.6	11.3	0.3	0.0	30.5	45.4	42.4	32.8	6.2	0.1	0.0
	Subtotal	1.93E-09	7.00E-10	4.03E-10	2.83E-10	1.53E-10	1.28E-10	1.03E-10	2.06E-09	8.28E-10	5.31E-10	4.11E-10	2.77E-10	2.48E-10	2.05E-10
Total, Sv.m ² .s ⁻¹		2.83E-09	1.15E-09	7.69E-10	6.13E-10	4.13E-10	3.36E-10	2.45E-10	3.37E-09	1.69E-09	1.31E-09	1.15E-09	9.47E-10	8.59E-10	7.25E-10

Table 16

Gamma-equivalents in TRT services by material (Type 1, 2, and 3)

		T=100 d							T=10 y						
Hadrons	Material	t= 1 d	t= 3 d	t= 5 d	t= 7 d	t= 15 d	t= 30 d	t= 100 d	t= 1 d	t= 3 d	t= 5 d	t= 7 d	t= 15 d	t= 30 d	t= 100 d
		Al	2.6	1.0	0.9	0.9	1.3	1.7	3.1	4.2	3.2	3.3	3.6	4.5	5.7
	Mn	5.5	5.8	5.8	5.7	5.4	5.0	5.9	6.0	6.4	6.5	6.5	6.4	6.4	7.7
	Fe	35.9	35.5	33.5	31.4	24.4	18.3	15.9	33.3	32.4	30.5	28.5	22.5	17.6	15.8
	Ni	10.4	10.7	10.9	11.3	12.7	14.3	15.1	10.1	10.3	10.4	10.6	11.6	12.4	11.5
	Cu	45.6	47.0	48.9	50.7	56.2	60.8	60.1	46.4	47.7	49.3	50.8	55.0	57.9	55.8
	Subtotal	1.37E-09	1.11E-09	9.78E-10	8.83E-10	6.60E-10	4.86E-10	2.47E-10	1.57E-09	1.31E-09	1.18E-09	1.08E-09	8.54E-10	6.69E-10	3.93E-10
Neutrons	Al	0.2	0.2	0.1	0.0	0.0	0.0	0.0	0.2	0.1	0.0	0.0	0.0	0.0	0.0
	Cr	0.8	7.0	15.5	16.6	14.7	11.3	2.9	0.8	3.7	4.9	4.9	4.1	2.9	0.6
	Mn	0.2	0.0	0.1	0.1	0.1	0.1	0.2	0.2	0.1	0.1	0.1	0.1	0.1	0.1
	Fe	0.8	6.7	15.1	16.6	16.2	15.1	10.1	0.9	4.3	5.9	6.0	5.6	4.9	2.9
	Co	1.8	15.3	35.5	39.9	43.0	48.2	68.3	11.2	55.2	77.6	80.4	82.2	84.9	92.3
	Ni	1.2	10.4	23.6	26.0	26.0	25.3	18.6	1.3	6.0	8.3	8.5	8.0	7.2	4.1
	Cu	95.0	60.3	10.2	0.8	0.0	0.0	0.0	85.4	30.6	3.1	0.2	0.0	0.0	0.0
	Subtotal	3.35E-09	3.85E-10	1.66E-10	1.48E-10	1.37E-10	1.21E-10	8.33E-11	3.72E-09	7.57E-10	5.38E-10	5.19E-10	5.06E-10	4.88E-10	4.37E-10
Total, Sv.m ² .s ⁻¹		4.72E-09	1.49E-09	1.14E-09	1.03E-09	7.96E-10	6.07E-10	3.30E-10	5.29E-09	2.07E-09	1.72E-09	1.60E-09	1.36E-09	1.16E-09	8.30E-10

Table 17

Gamma-equivalents in SCT Barrel by material

		T=100 d							T=10 y						
Material		t= 1 d	t= 3 d	t= 5 d	t= 7 d	t= 15 d	t= 30 d	t= 100 d	t= 1 d	t= 3 d	t= 5 d	t= 7 d	t= 15 d	t= 30 d	t= 100 d
		Hadrons	Be	0.1	0.1	0.2	0.2	0.2	0.2	0.1	0.1	0.1	0.1	0.1	0.1
C	2.7		4.5	5.1	5.4	5.8	5.8	3.6	2.0	2.6	2.8	2.8	2.8	2.5	1.2
Al	22.6		10.9	9.2	9.5	11.2	13.4	19.6	25.7	20.7	20.6	21.2	23.0	24.8	28.9
Si	20.8		15.7	15.8	16.8	19.8	23.6	34.4	32.7	34.4	36.1	37.3	40.4	43.7	50.8
Ni	4.2		6.2	6.6	6.7	6.8	6.8	5.6	3.1	3.8	3.8	3.7	3.5	3.2	2.1
Cu	29.1		42.2	44.9	45.1	43.8	41.4	31.7	22.4	26.9	27.0	26.4	24.1	21.5	14.7
Pb	20.3		20.0	17.7	15.8	11.9	8.4	4.7	13.9	11.3	9.5	8.3	5.9	4.0	2.1
Subtotal	2.96E-10		1.74E-10	1.49E-10	1.38E-10	1.16E-10	9.56E-11	6.16E-11	4.47E-10	3.25E-10	3.00E-10	2.88E-10	2.64E-10	2.42E-10	1.97E-10
Neutrons	Al		2.1	0.6	0.1	0.0	0.0	0.0	0.0	1.8	0.4	0.1	0.0	0.0	0.0
	Co	0.4	1.0	1.3	1.5	1.9	2.0	2.4	2.3	4.7	5.6	6.1	7.0	7.4	8.6
	Ni	0.4	1.0	1.3	1.5	1.7	1.6	1.0	0.4	0.8	0.9	1.0	1.0	0.9	0.6
	Cu	51.8	9.5	0.9	0.1	0.0	0.0	0.0	43.5	6.4	0.6	0.0	0.0	0.0	0.0
	Ag	19.9	49.7	65.8	75.7	92.9	96.2	96.5	30.7	61.8	74.1	80.5	90.0	91.5	90.7
	Sn	0.1	0.2	0.2	0.2	0.2	0.2	0.1	0.1	0.1	0.2	0.2	0.2	0.1	0.1
	Au	25.4	38.1	30.4	21.0	3.4	0.1	0.0	21.3	25.8	18.6	12.2	1.8	0.0	0.0
	Subtotal	2.37E-10	9.42E-11	7.07E-11	6.12E-11	4.88E-11	4.52E-11	3.71E-11	2.82E-10	1.39E-10	1.15E-10	1.06E-10	9.24E-11	8.72E-11	7.25E-11
Total, Sv.m ² .s ⁻¹	5.33E-10	2.68E-10	2.20E-10	1.99E-10	1.64E-10	1.41E-10	9.86E-11	7.29E-10	4.64E-10	4.15E-10	3.94E-10	3.57E-10	3.29E-10	2.69E-10	

Table 18

Gamma-equivalents in SCT Forward by material

		T=100 d							T=10 y						
Material		t= 1 d	t= 3 d	t= 5 d	t= 7 d	t= 15 d	t= 30 d	t= 100 d	t= 1 d	t= 3 d	t= 5 d	t= 7 d	t= 15 d	t= 30 d	t= 100 d
		Hadrons	Be	0.1	0.2	0.2	0.2	0.2	0.2	0.1	0.1	0.1	0.1	0.1	0.1
C	6.4		12.7	14.8	15.5	16.1	15.7	9.4	4.7	6.9	7.3	7.3	7.1	6.2	3.0
Al	54.1		30.9	26.6	27.2	31.1	36.0	50.7	61.1	53.2	53.2	54.3	57.6	61.2	69.4
Si	6.6		5.7	5.8	6.0	6.9	8.0	11.2	10.0	11.2	11.7	12.0	12.8	13.5	15.3
Ni	1.8		3.2	3.5	3.6	3.6	3.5	2.8	1.3	1.8	1.8	1.8	1.7	1.5	1.0
Cu	20.4		35.0	37.9	37.5	34.7	31.4	22.7	15.6	20.4	20.4	19.7	17.4	15.0	9.9
Pb	10.4		12.3	11.1	9.9	7.2	5.1	2.9	7.2	6.5	5.4	4.7	3.3	2.3	1.3
Subtotal	5.67E-10		2.79E-10	2.34E-10	2.18E-10	1.88E-10	1.60E-10	1.06E-10	8.55E-10	5.67E-10	5.20E-10	5.04E-10	4.72E-10	4.38E-10	3.66E-10
Neutrons	Co		0.3	0.6	0.7	0.8	1.0	1.1	1.3	1.6	2.7	3.2	3.5	4.0	4.2
	Ni	0.2	0.3	0.4	0.4	0.5	0.5	0.3	0.1	0.2	0.3	0.3	0.3	0.3	0.2
	Cu	33.5	4.9	0.5	0.0	0.0	0.0	0.0	27.0	3.3	0.3	0.0	0.0	0.0	0.0
	Ag	26.4	52.5	67.1	77.1	94.8	98.2	98.3	39.1	65.4	76.7	83.4	93.7	95.4	94.8
	Sn	0.1	0.1	0.2	0.2	0.2	0.1	0.1	0.1	0.1	0.1	0.2	0.1	0.1	0.1
	Au	33.7	40.3	31.0	21.4	3.5	0.1	0.0	27.2	27.3	19.3	12.6	1.9	0.0	0.0
	Al	5.9	1.3	0.2	0.0	0.0	0.0	0.0	4.8	0.9	0.1	0.0	0.0	0.0	0.0
	Subtotal	4.85E-10	2.42E-10	1.89E-10	1.63E-10	1.30E-10	1.20E-10	9.90E-11	6.01E-10	3.57E-10	3.03E-10	2.77E-10	2.41E-10	2.27E-10	1.88E-10
Total, Sv.m ² .s ⁻¹	1.05E-09	5.22E-10	4.22E-10	3.81E-10	3.18E-10	2.80E-10	2.05E-10	1.46E-09	9.24E-10	8.23E-10	7.81E-10	7.13E-10	6.66E-10	5.55E-10	

Table 19

Gamma-equivalents in SCT Barrel services by material (Type 1 and 2)

		T=100 d							T=10 y						
Hadrons	Material	t= 1 d	t= 3 d	t= 5 d	t= 7 d	t= 15 d	t= 30 d	t= 100 d	t= 1 d	t= 3 d	t= 5 d	t= 7 d	t= 15 d	t= 30 d	t= 100 d
		Al	0.9	0.3	0.3	0.3	0.3	0.4	0.7	1.4	1.0	1.0	1.0	1.2	1.4
	Ni	20.5	20.7	20.4	20.4	20.9	21.6	22.6	19.7	19.7	19.4	19.4	19.5	19.8	19.0
	Cu	78.6	79.0	79.3	79.3	78.8	78.0	76.6	78.9	79.3	79.6	79.6	79.3	78.8	78.6
Neutrons	Subtotal	1.54E-09	1.28E-09	1.17E-09	1.10E-09	9.09E-10	7.27E-10	3.70E-10	1.79E-09	1.53E-09	1.42E-09	1.34E-09	1.14E-09	9.44E-10	5.34E-10
	Co	2.1	19.8	52.3	59.8	62.2	65.5	78.5	12.0	61.5	87.8	90.8	91.6	92.7	96.0
	Ni	1.4	13.5	34.9	39.1	37.8	34.5	21.5	1.3	6.3	8.8	8.9	8.4	7.3	4.0
	Cu	96.5	66.7	12.8	1.1	0.0	0.0	0.0	86.7	32.2	3.4	0.3	0.0	0.0	0.0
	Subtotal	5.84E-09	6.16E-10	2.33E-10	2.04E-10	1.95E-10	1.84E-10	1.50E-10	6.60E-09	1.37E-09	9.86E-10	9.56E-10	9.45E-10	9.29E-10	8.71E-10
Total, Sv.m ² .s ⁻¹		7.38E-09	1.90E-09	1.41E-09	1.30E-09	1.10E-09	9.11E-10	5.19E-10	8.39E-09	2.90E-09	2.40E-09	2.29E-09	2.09E-09	1.87E-09	1.40E-09

Table 20

Gamma-equivalents in SCT Forward services by material (Type 1 and 2)

		T=100 d							T=10 y						
Hadrons	Material	t= 1 d	t= 3 d	t= 5 d	t= 7 d	t= 15 d	t= 30 d	t= 100 d	t= 1 d	t= 3 d	t= 5 d	t= 7 d	t= 15 d	t= 30 d	t= 100 d
		Ni	18.5	18.7	18.7	18.8	19.5	20.4	21.7	17.9	18.0	17.9	18.0	18.4	18.8
	Cu	81.5	81.3	81.3	81.2	80.5	79.6	78.3	82.1	82.0	82.1	82.0	81.6	81.2	81.6
	Subtotal	1.20E-09	1.01E-09	9.17E-10	8.54E-10	7.02E-10	5.56E-10	2.79E-10	1.38E-09	1.19E-09	1.10E-09	1.03E-09	8.74E-10	7.16E-10	3.99E-10
Neutrons	Co	1.9	18.5	50.7	58.6	61.0	64.3	77.7	13.1	63.1	87.5	90.2	91.0	92.1	95.7
	Ni	1.4	13.2	35.6	40.3	39.0	35.7	22.3	1.5	6.9	9.5	9.6	9.0	7.9	4.3
	Cu	96.7	68.3	13.7	1.1	0.0	0.0	0.0	85.4	30.0	3.0	0.2	0.0	0.0	0.0
	Subtotal	3.45E-09	3.56E-10	1.29E-10	1.12E-10	1.07E-10	1.01E-10	8.16E-11	3.85E-09	7.62E-10	5.36E-10	5.18E-10	5.11E-10	5.02E-10	4.70E-10
Total, Sv.m ² .s ⁻¹		4.64E-09	1.36E-09	1.05E-09	9.67E-10	8.09E-10	6.57E-10	3.60E-10	5.24E-09	1.95E-09	1.63E-09	1.55E-09	1.39E-09	1.22E-09	8.69E-10

Table 21

Gamma-equivalents in PIXEL and Type 1 services by material

		T=100 d							T=10 y						
	Material	t= 1 d	t= 3 d	t= 5 d	t= 7 d	t= 15 d	t= 30 d	t= 100 d	t= 1 d	t= 3 d	t= 5 d	t= 7 d	t= 15 d	t= 30 d	t= 100 d
Hadrons	Al	42.4	20.2	16.9	17.6	21.4	26.5	41.4	52.1	42.8	43.3	45.0	50.3	56.1	69.1
	Ti	0.4	0.6	0.6	0.5	0.5	0.5	0.5	0.4	0.4	0.4	0.4	0.3	0.3	0.2
	Mn	1.2	1.7	1.8	1.8	1.5	1.2	0.9	1.0	1.3	1.3	1.3	1.1	0.9	0.7
	Fe	4.7	6.5	6.4	6.0	4.3	2.9	1.8	3.7	4.4	4.1	3.7	2.6	1.7	1.0
	Ni	6.6	10.2	11.2	11.5	12.3	12.8	11.3	5.5	7.2	7.5	7.5	7.4	7.0	4.9
	Cu	36.8	53.0	56.3	56.4	55.0	52.3	41.5	31.2	38.7	39.1	38.3	35.4	31.7	22.6
	Pb	7.8	7.7	6.8	6.2	4.9	3.9	2.7	6.0	5.2	4.4	3.9	3.0	2.3	1.5
	Subtotal	3.08E-09	1.78E-09	1.51E-09	1.38E-09	1.12E-09	8.88E-10	5.28E-10	4.17E-09	2.87E-09	2.59E-09	2.46E-09	2.19E-09	1.93E-09	1.49E-09
Neutrons	Cr	0.1	0.9	1.9	2.1	1.9	1.4	0.3	0.1	0.6	1.0	1.0	0.8	0.6	0.1
	Mn	0.1	0.1	0.2	0.2	0.2	0.2	0.2	0.1	0.1	0.2	0.2	0.2	0.2	0.2
	Fe	0.1	0.5	1.1	1.3	1.3	1.1	0.7	0.1	0.5	0.7	0.8	0.7	0.7	0.5
	Co	0.5	3.9	9.3	10.7	11.5	12.2	14.9	3.1	18.9	31.3	33.5	34.8	36.0	41.0
	Ni	0.5	3.9	9.1	10.3	10.3	9.5	6.0	0.5	3.1	5.0	5.3	5.1	4.6	2.7
	Cu	87.7	53.9	9.3	0.8	0.0	0.0	0.0	83.2	36.9	4.4	0.3	0.0	0.0	0.0
	Zn	0.1	0.6	1.5	1.7	1.8	1.9	1.9	0.1	0.8	1.3	1.4	1.4	1.4	1.4
	Ag	3.0	24.8	58.4	66.9	70.9	72.5	75.1	5.2	31.2	51.4	54.6	55.7	55.7	53.5
	Sn	0.1	0.7	1.5	1.6	1.3	1.0	0.7	0.1	0.6	1.0	1.0	0.9	0.7	0.6
	Au	0.8	4.0	5.7	3.9	0.5	0.0	0.0	0.8	2.8	2.7	1.7	0.2	0.0	0.0
	Al	7.0	6.4	1.7	0.2	0.0	0.0	0.0	6.7	4.4	0.8	0.1	0.0	0.0	0.0
	Subtotal	7.28E-10	8.64E-11	3.65E-11	3.17E-11	2.93E-11	2.75E-11	2.19E-11	7.68E-10	1.26E-10	7.63E-11	7.13E-11	6.84E-11	6.56E-11	5.63E-11
Total, Sv.m ² .s ⁻¹		3.81E-09	1.86E-09	1.54E-09	1.41E-09	1.15E-09	9.16E-10	5.50E-10	4.94E-09	2.99E-09	2.67E-09	2.53E-09	2.25E-09	2.00E-09	1.54E-09

Table 22

Gamma-equivalents in PIXEL Services by material (Type 2 only)

		T=100 d							T=10 y						
	Material	t= 1 d	t= 3 d	t= 5 d	t= 7 d	t= 15 d	t= 30 d	t= 100 d	t= 1 d	t= 3 d	t= 5 d	t= 7 d	t= 15 d	t= 30 d	t= 100 d
Hadrons	Al	22.4	9.5	8.0	8.2	9.6	11.5	19.3	31.3	24.6	24.8	25.7	28.8	32.6	45.2
	Ni	31.1	36.4	36.8	36.7	36.8	37.0	35.1	26.9	29.4	29.1	28.7	27.7	26.6	21.2
	Cu	46.4	54.0	55.2	55.1	53.6	51.5	45.6	41.9	46.0	46.1	45.6	43.5	40.9	33.7
	Subtotal	9.08E-10	6.52E-10	5.83E-10	5.46E-10	4.61E-10	3.78E-10	2.13E-10	1.18E-09	9.18E-10	8.48E-10	8.09E-10	7.18E-10	6.27E-10	4.29E-10
Neutrons	Al	2.1	1.4	0.3	0.0	0.0	0.0	0.0	1.6	0.5	0.1	0.0	0.0	0.0	0.0
	Co	5.1	32.7	54.5	57.8	59.9	63.2	76.8	27.6	76.6	88.3	89.4	90.2	91.4	95.3
	Ni	3.9	24.6	40.2	41.8	40.1	36.8	23.2	3.4	9.3	10.5	10.5	9.8	8.6	4.7
	Cu	88.9	41.3	5.0	0.4	0.0	0.0	0.0	67.4	13.6	1.1	0.1	0.0	0.0	0.0
	Subtotal	1.37E-09	2.16E-10	1.29E-10	1.22E-10	1.17E-10	1.10E-10	8.85E-11	1.81E-09	6.52E-10	5.66E-10	5.58E-10	5.51E-10	5.41E-10	5.06E-10
Total, Sv.m ² .s ⁻¹		2.28E-09	8.68E-10	7.13E-10	6.68E-10	5.78E-10	4.89E-10	3.01E-10	2.99E-09	1.57E-09	1.41E-09	1.37E-09	1.27E-09	1.17E-09	9.35E-10

Table 23

Gamma-equivalents in ID beam-pipe by material

		T=100 d							T=10 y						
Material		t= 1 d	t= 3 d	t= 5 d	t= 7 d	t= 15 d	t= 30 d	t= 100 d	t= 1 d	t= 3 d	t= 5 d	t= 7 d	t= 15 d	t= 30 d	t= 100 d
		Hadrons	Be	21.6	46.5	53.6	54.5	53.9	50.9	32.2	15.8	24.2	25.5	25.4	23.9
Al	73.2		44.0	36.6	36.4	39.3	44.1	64.3	80.2	70.5	69.4	69.9	72.5	76.3	87.8
Ti	0.3		0.6	0.5	0.5	0.4	0.4	0.3	0.2	0.3	0.3	0.2	0.2	0.2	0.1
Mn	2.4		4.5	4.7	4.4	3.4	2.5	1.8	1.9	2.6	2.6	2.4	1.9	1.5	1.1
Fe	1.7		3.1	3.0	2.7	1.7	1.1	0.6	1.2	1.6	1.4	1.3	0.8	0.5	0.3
Cu	0.8		1.4	1.5	1.5	1.2	1.1	0.8	0.6	0.8	0.8	0.7	0.6	0.5	0.4
Subtotal	2.06E-10		9.31E-11	7.87E-11	7.54E-11	6.87E-11	5.99E-11	3.81E-11	3.09E-10	1.96E-10	1.81E-10	1.77E-10	1.70E-10	1.59E-10	1.31E-10
Neutrons	Al		84.1	75.8	38.4	7.0	0.0	0.0	0.0	83.1	68.8	26.1	3.9	0.0	0.0
	Ti	0.2	1.0	3.9	5.6	5.3	4.9	3.5	0.2	1.1	3.0	3.6	3.3	3.0	2.1
	Cr	0.1	1.0	4.5	7.2	6.7	4.9	1.1	0.1	0.9	3.1	4.1	3.7	2.7	0.6
	Mn	1.7	5.7	26.6	44.6	49.8	51.5	56.0	2.4	11.0	38.2	52.7	56.1	57.1	60.2
	Fe	0.1	1.2	5.4	9.0	9.8	9.6	9.1	0.3	1.9	6.7	9.2	9.6	9.5	9.3
	Zn	0.4	3.3	15.3	25.6	28.4	29.1	30.3	0.8	5.4	18.8	25.8	27.4	27.6	27.9
	Mg	12.9	11.6	5.9	1.1	0.0	0.0	0.0	12.7	10.6	4.0	0.6	0.0	0.0	0.0
	Subtotal	4.31E-12	5.20E-13	1.12E-13	6.64E-14	5.83E-14	5.46E-14	4.30E-14	4.36E-12	5.73E-13	1.65E-13	1.19E-13	1.10E-13	1.04E-13	8.46E-14
Total, Sv.m ² .s ⁻¹		2.10E-10	9.36E-11	7.88E-11	7.54E-11	6.88E-11	6.00E-11	3.81E-11	3.13E-10	1.96E-10	1.81E-10	1.77E-10	1.70E-10	1.59E-10	1.31E-10

Table 24

Gamma-equivalents in LAr beam-pipe by material

		T=100 d							T=10 y						
Hadrons	Material	t= 1 d	t= 3 d	t= 5 d	t= 7 d	t= 15 d	t= 30 d	t= 100 d	t= 1 d	t= 3 d	t= 5 d	t= 7 d	t= 15 d	t= 30 d	t= 100 d
		Mn	9.2	9.5	9.8	10.0	10.6	10.5	11.3	10.2	10.7	11.1	11.5	12.6	13.4
	Fe	67.3	65.8	63.9	61.8	53.8	44.5	37.4	65.5	63.9	61.9	59.9	52.6	45.1	41.4
	Ni	23.4	24.6	26.3	28.1	35.5	44.9	51.1	24.1	25.3	26.8	28.4	34.6	41.2	41.9
	Subtotal	9.37E-08	7.65E-08	6.57E-08	5.76E-08	3.87E-08	2.51E-08	1.16E-08	1.02E-07	8.50E-08	7.41E-08	6.59E-08	4.66E-08	3.25E-08	1.72E-08
Neutrons	Cr	1.2	1.2	1.2	1.1	1.0	0.8	0.2	0.9	0.9	0.8	0.8	0.7	0.5	0.1
	Mn	0.8	0.5	0.5	0.5	0.5	0.6	0.9	0.9	0.7	0.7	0.7	0.7	0.8	1.0
	Fe	9.0	9.1	9.2	9.4	9.8	10.6	15.5	12.5	12.6	12.8	12.9	13.4	14.2	18.1
	Co	3.9	4.0	4.1	4.1	4.4	5.0	8.3	17.6	17.9	18.2	18.5	19.5	21.5	31.8
	Ni	83.4	84.0	84.1	84.1	83.9	82.9	75.1	67.0	67.0	66.8	66.6	65.4	62.8	48.9
	Mo	1.6	1.2	1.0	0.8	0.4	0.2	0.0	1.1	0.9	0.7	0.5	0.3	0.1	0.0
	Subtotal	2.43E-09	2.37E-09	2.32E-09	2.28E-09	2.11E-09	1.84E-09	1.03E-09	3.48E-09	3.41E-09	3.36E-09	3.31E-09	3.11E-09	2.80E-09	1.84E-09
Total, Sv.m ² .s ⁻¹		9.61E-08	7.89E-08	6.80E-08	5.99E-08	4.08E-08	2.69E-08	1.00E+02	1.06E-07	8.84E-08	7.74E-08	6.92E-08	4.97E-08	3.53E-08	1.91E-08

Table 25

Dose rate at R= 175 mm, Z= 3340 mm for exposure time T=100 days and different cooling time

Type	Element	Cooling time, t						
		1 d	3 d	5 d	7 d	15 d	30 d	100 d
Hadron activation	ID beam pipe	7.17	2.57	2.00	1.89	1.73	1.56	1.21
	LAr beam pipe	247	205	176	155	104	66.9	30.3
	Pixel type 2 services	9.31	6.58	5.87	5.48	4.61	3.78	2.13
	Pixel	156.00	75.90	62.70	57.90	48.40	39.90	26.40
	SCT barrel	0.20	0.12	0.10	0.09	0.08	0.06	0.04
	SCT forward	1.18	0.56	0.47	0.44	0.38	0.33	0.22
	SCT barrel services	2.58	2.16	1.97	1.84	1.53	1.22	0.62
	SCT forward services	4.03	3.39	3.09	2.88	2.36	1.86	0.93
	TRT	1.57	0.77	0.61	0.55	0.43	0.34	0.24
	TRT services	2.46	2.00	1.76	1.60	1.20	0.89	0.45
	LAr Barrel	14.8	9.50	7.40	6.20	3.70	2.10	1.80
	LAr EndCap	27.0	15.8	13.0	11.3	7.90	5.20	2.40
Neutron activation	ID beam pipe	0.16	0.02	0.00	0.00	0.00	0.00	0.00
	LAr beam pipe	6.39	6.14	5.99	5.87	5.44	4.78	2.87
	Pixel type 2 services	8.98	1.44	0.87	0.82	0.79	0.74	0.58
	Pixel	25.60	2.37	0.52	0.34	0.27	0.23	0.16
	SCT barrel	0.16	0.06	0.05	0.04	0.03	0.03	0.02
	SCT forward	0.88	0.44	0.34	0.30	0.24	0.22	0.18
	SCT barrel services	9.48	0.99	0.37	0.32	0.31	0.29	0.24
	SCT forward services	10.9	1.12	0.41	0.35	0.34	0.32	0.26
	TRT	3.60	1.30	0.68	0.42	0.14	0.10	0.08
	TRT services	5.80	0.65	0.28	0.24	0.23	0.20	0.14
	LAr Barrel	17.0	1.00	0.70	0.67	0.61	0.51	0.40
	LAr EndCap	2.50	0.90	0.60	0.45	0.42	0.40	0.38
Total , μ Sv/h		564.75	340.78	285.78	254.99	185.14	131.96	72.05

Table 26

Dose rate at R= 175 mm, Z= 3340 mm for exposure time T=10 years and different cooling time

Type	Element	Cooling time, t						
		1 d	3 d	5 d	7 d	15 d	30 d	100 d
Hadron activation	ID beam pipe	11.40	6.64	6.05	5.94	5.82	5.58	5.02
	LAr beam pipe	270.00	227.00	198.00	177.00	126.00	87.30	45.70
	Pixel type 2 services	12.10	9.38	8.66	8.26	7.34	6.41	4.43
	Pixel	227.00	147.00	133.00	128.00	118.00	108.00	90.30
	SCT barrel	0.30	0.22	0.20	0.19	0.18	0.16	0.13
	SCT forward	1.80	1.18	1.08	1.05	0.99	0.93	0.78
	SCT barrel services	3.00	2.57	2.38	2.24	1.92	1.58	0.89
	SCT forward services	4.65	4.01	3.70	3.48	2.93	2.40	1.33
	TRT	2.31	1.50	1.35	1.28	1.16	1.06	0.91
	TRT services	2.84	2.37	2.14	1.96	1.55	1.22	0.72
	LAr Barrel	18.70	14.60	11.80	10.00	6.40	5.90	5.50
	LAr EndCap	32.00	21.40	18.00	15.90	11.80	9.00	6.70
Neutron activation	ID beam pipe	0.16	0.02	0.01	0.00	0.00	0.00	0.00
	LAr beam pipe	12.80	12.50	12.40	12.20	11.70	11.00	8.62
	Pixel type 2 services	11.80	4.21	3.64	3.59	3.55	3.47	3.23
	Pixel	25.90	2.72	0.87	0.69	0.62	0.57	0.48
	SCT barrel	0.19	0.09	0.08	0.07	0.06	0.06	0.05
	SCT forward	1.09	0.65	0.55	0.50	0.44	0.41	0.34
	SCT barrel services	10.70	2.16	1.54	1.49	1.47	1.44	1.35
	SCT forward services	12.20	2.40	1.69	1.63	1.61	1.58	1.48
	TRT	3.69	1.40	0.77	0.51	0.23	0.19	0.15
	TRT services	6.40	1.26	0.88	0.84	0.82	0.79	0.71
	LAr Barrel	19.00	2.40	2.20	2.16	2.07	1.95	1.80
	LAr EndCap	4.40	3.50	2.50	2.40	2.30	2.20	2.20
Total , μ Sv/h		694.43	471.18	413.49	381.38	308.96	253.2	182.82

Table 27

Dose rate at R= 400 mm, Z= 3443 mm for exposure time T=100 days and different cooling time

Type	Element	Cooling time, t						
		1 d	3 d	5 d	7 d	15 d	30 d	100 d
Hadron activation	ID beam pipe	3.26	1.12	0.86	0.81	0.74	0.67	0.55
	LAr beam pipe	214	177	153	134	90	58	26
	Pixel type 2 services	30.40	21.40	19.00	17.80	14.90	12.20	6.86
	Pixel	31.50	18.50	15.80	14.60	11.90	9.54	5.66
	SCT barrel	0.19	0.11	0.09	0.09	0.07	0.06	0.04
	SCT forward	0.96	0.46	0.38	0.36	0.31	0.27	0.18
	SCT barrel services	2.53	2.11	1.93	1.80	1.50	1.20	0.61
	SCT forward services	3.71	3.12	2.84	2.64	2.17	1.71	0.86
	TRT	1.55	0.75	0.60	0.54	0.42	0.34	0.23
	TRT services	2.48	2.01	1.78	1.61	1.21	0.89	0.46
	LAr Barrel	14.80	9.40	7.40	6.20	3.70	2.10	1.80
	LAr EndCap	23.00	13.40	11.00	9.60	6.70	4.70	2.20
Neutron activation	ID beam pipe	0.08	0.01	0.00	0.00	0.00	0.00	0.00
	LAr beam pipe	5.64	5.43	5.30	5.19	4.81	4.23	2.52
	Pixel type 2 services	24.20	3.95	2.43	2.30	2.20	2.05	1.59
	Pixel	11.70	1.01	0.18	0.10	0.06	0.05	0.04
	SCT barrel	0.15	0.06	0.04	0.04	0.03	0.03	0.02
	SCT forward	0.73	0.37	0.28	0.25	0.20	0.18	0.15
	SCT barrel services	9.23	0.97	0.36	0.31	0.30	0.28	0.23
	SCT forward services	10.30	1.06	0.38	0.33	0.32	0.30	0.24
	TRT	3.56	1.30	0.67	0.41	0.13	0.09	0.07
	TRT services	5.84	0.66	0.28	0.25	0.23	0.20	0.14
	LAr Barrel	17.00	1.00	0.70	0.67	0.61	0.51	0.40
	LAr EndCap	2.30	0.90	0.50	0.37	0.35	0.33	0.30
Total , $\mu\text{Sv/h}$		419.11	266.1	225.8	200.27	142.86	99.93	51.15

Table 28

Dose rate at R= 400 mm, Z= 3443 mm for exposure time T=10 years and different cooling time

Type	Element	Cooling time, t						
		1 d	3 d	5 d	7 d	15 d	30 d	100 d
Hadron activation	ID beam pipe	5.22	3.02	2.75	2.69	2.65	2.55	2.33
	LAr beam pipe	233	196	172	153	109	76	40
	Pixel type 2 services	39.60	30.50	28.10	26.80	23.80	20.80	14.40
	Pixel	43.40	30.30	27.60	26.30	23.60	20.90	16.10
	SCT barrel	0.28	0.20	0.19	0.18	0.17	0.15	0.12
	SCT forward	1.47	0.96	0.88	0.86	0.81	0.76	0.64
	SCT barrel services	2.93	2.51	2.32	2.19	1.87	1.55	0.87
	SCT forward services	4.28	3.68	3.40	3.20	2.70	2.21	1.23
	TRT	2.27	1.47	1.32	1.25	1.13	1.03	0.89
	TRT services	2.87	2.39	2.15	1.98	1.57	1.23	0.73
	LAr Barrel	18.70	14.60	11.80	10.00	6.40	5.90	5.50
	LAr EndCap	28.00	19.10	16.00	14.20	10.50	8.00	6.00
Neutron activation	ID beam pipe	0.08	0.01	0.00	0.00	0.00	0.00	0.00
	LAr beam pipe	11.00	10.80	10.70	10.50	10.10	9.40	7.32
	Pixel type 2 services	31.60	11.30	9.80	9.65	9.52	9.32	8.61
	Pixel	11.80	1.08	0.25	0.17	0.14	0.12	0.10
	SCT barrel	0.18	0.09	0.07	0.07	0.06	0.05	0.04
	SCT forward	0.90	0.54	0.46	0.42	0.36	0.34	0.28
	SCT barrel services	10.40	2.10	1.49	1.45	1.43	1.40	1.31
	SCT forward services	11.50	2.27	1.59	1.54	1.52	1.49	1.40
	TRT	3.65	1.38	0.76	0.50	0.22	0.17	0.14
	TRT services	6.45	1.26	0.88	0.85	0.83	0.80	0.71
	LAr Barrel	19.00	2.40	2.20	2.16	2.07	1.95	1.80
	LAr EndCap	4.20	3.00	2.10	2.07	2.00	1.95	1.90
Total , $\mu\text{Sv/h}$		492.78	340.96	298.81	272.03	212.45	168.07	112.42

Table 29

Dose rate at R= 700 mm, Z= 3440 mm for exposure time T=100 days and different cooling time

Type	Element	Cooling time, t						
		1 d	3 d	5 d	7 d	15 d	30 d	100 d
Hadron activation	ID beam pipe	1.20	0.43	0.34	0.32	0.29	0.26	0.20
	LAr beam pipe	127.	105.	90.5	79.7	53.5	34.5	15.8
	Pixel type 2 services	25.6	18.1	16.2	15.2	12.8	10.5	5.97
	Pixel	12.30	7.23	6.20	5.72	4.68	3.75	2.23
	SCT barrel	0.18	0.11	0.09	0.08	0.07	0.06	0.04
	SCT forward	0.85	0.40	0.34	0.32	0.28	0.24	0.16
	SCT barrel services	2.84	2.38	2.17	2.03	1.69	1.35	0.69
	SCT forward services	3.91	3.29	3.00	2.79	2.30	1.82	0.91
	TRT	1.73	0.84	0.67	0.60	0.47	0.38	0.26
	TRT services	2.93	2.38	2.10	1.90	1.43	1.06	0.54
	LAr Barrel	13.9	8.86	6.90	5.78	3.45	1.96	1.80
	LAr EndCap	19.0	11.3	9.30	8.08	5.65	3.72	1.70
Neutron activation	ID beam pipe	0.03	0.00	0.00	0.00	0.00	0.00	0.00
	LAr beam pipe	3.50	3.38	3.31	3.24	3.00	2.63	1.54
	Pixel type 2 services	28.5	4.46	2.66	2.50	2.41	2.27	1.81
	Pixel	4.64	0.39	0.06	0.04	0.03	0.02	0.02
	SCT barrel	0.14	0.06	0.04	0.04	0.03	0.03	0.02
	SCT forward	0.65	0.33	0.25	0.22	0.17	0.16	0.13
	SCT barrel services	10.3	1.08	0.40	0.35	0.34	0.32	0.25
	SCT forward services	11.2	1.16	0.42	0.37	0.35	0.33	0.27
	TRT	3.95	1.43	0.74	0.45	0.14	0.09	0.07
	TRT services	6.83	0.77	0.32	0.29	0.26	0.23	0.16
	LAr Barrel	15.6	1.03	0.72	0.69	0.63	0.52	0.44
	LAr EndCap	2.00	0.65	0.43	0.32	0.31	0.30	0.29
Total , μ Sv/h		298.78	175.06	147.16	131.03	94.28	66.5	35.3

Table 30

Dose rate at R= 700 mm, Z= 3440 mm for exposure time T=10 years and different cooling time

Type	Element	Cooling time, t						
		1 d	3 d	5 d	7 d	15 d	30 d	100 d
Hadron activation	ID beam pipe	1.90	1.11	1.02	1.00	0.98	0.93	0.84
	LAr beam pipe	138.0	116.0	102.0	90.8	64.8	45.0	23.7
	Pixel type 2 services	33.5	26.0	24.0	22.9	20.4	17.9	12.4
	Pixel	17.00	11.90	10.80	10.30	9.24	8.21	6.31
	SCT barrel	0.27	0.20	0.18	0.18	0.16	0.15	0.12
	SCT forward	1.29	0.85	0.78	0.76	0.71	0.67	0.56
	SCT barrel services	3.30	2.83	2.62	2.47	2.11	1.74	0.98
	SCT forward services	4.52	3.89	3.59	3.38	2.86	2.34	1.30
	TRT	2.55	1.65	1.48	1.41	1.28	1.17	1.01
	TRT services	3.38	2.82	2.54	2.34	1.85	1.46	0.86
	LAr Barrel	18.4	13.9	11.3	9.58	6.33	6.23	5.90
	LAr EndCap	23.0	15.8	13.2	11.7	8.66	6.81	5.11
Neutron activation	ID beam pipe	0.03	0.00	0.00	0.00	0.00	0.00	0.00
	LAr beam pipe	6.29	6.16	6.08	6.00	5.73	5.29	3.97
	Pixel type 2 services	37.4	13.3	11.5	11.3	11.2	11.0	10.3
	Pixel	4.68	0.43	0.10	0.07	0.06	0.06	0.05
	SCT barrel	0.17	0.08	0.07	0.06	0.06	0.05	0.04
	SCT forward	0.81	0.48	0.41	0.37	0.32	0.30	0.25
	SCT barrel services	11.6	2.34	1.66	1.61	1.59	1.56	1.46
	SCT forward services	12.5	2.48	1.74	1.69	1.67	1.64	1.53
	TRT	4.04	1.52	0.83	0.54	0.22	0.17	0.14
	TRT services	7.54	1.47	1.03	0.99	0.96	0.93	0.83
	LAr Barrel	17.1	2.30	2.11	2.07	1.99	1.84	1.70
	LAr EndCap	3.44	2.56	1.79	1.76	1.70	1.62	1.58
Total , μ Sv/h		352.71	230.07	200.83	183.28	144.88	117.07	80.94

Table 31

Dose rate at R= 175 mm, Z= 3800 mm for exposure time T=100 days and different cooling time

Type	Element	Cooling time, t						
		1 d	3 d	5 d	7 d	15 d	30 d	100 d
Hadron activation	ID beam pipe	8.41	2.67	1.98	1.86	1.70	1.57	1.37
	LAr beam pipe	1250.	1040.	893.	786.	527.	338.	153.
	Pixel type 2 services	5.96	4.22	3.77	3.52	2.97	2.43	1.37
	Pixel	14.40	8.45	7.22	6.65	5.42	4.31	2.54
	SCT barrel	0.15	0.09	0.08	0.07	0.06	0.05	0.03
	SCT forward	0.66	0.32	0.26	0.25	0.21	0.18	0.12
	SCT barrel services	1.91	1.60	1.46	1.36	1.13	0.91	0.46
	SCT forward services	2.54	2.13	1.94	1.81	1.49	1.18	0.59
	TRT	1.11	0.54	0.43	0.39	0.31	0.25	0.17
	TRT services	1.94	1.57	1.39	1.26	0.94	0.70	0.36
	LAr Barrel	11.3	7.07	5.51	4.62	2.76	1.56	1.53
	LAr EndCap	31.0	18.5	15.2	13.2	9.24	6.08	3.03
Neutron activation	ID beam pipe	0.25	0.03	0.01	0.00	0.00	0.00	0.00
	LAr beam pipe	33.0	31.5	30.7	30.1	27.9	24.5	15.2
	Pixel type 2 services	6.21	0.99	0.60	0.56	0.54	0.51	0.40
	Pixel	4.52	0.39	0.07	0.04	0.03	0.03	0.02
	SCT barrel	0.12	0.05	0.04	0.03	0.03	0.02	0.02
	SCT forward	0.51	0.26	0.20	0.17	0.14	0.13	0.10
	SCT barrel services	6.99	0.73	0.27	0.24	0.23	0.22	0.17
	SCT forward services	7.18	0.74	0.27	0.23	0.22	0.21	0.17
	TRT	2.33	0.83	0.44	0.28	0.10	0.07	0.06
	TRT services	4.61	0.52	0.22	0.19	0.18	0.16	0.11
	LAr Barrel	14.2	0.75	0.52	0.50	0.45	0.38	0.30
	LAr EndCap	3.10	0.90	0.60	0.45	0.42	0.41	0.40
Total , μ Sv/h		1412.4	1124.85	966.18	853.78	583.47	383.86	181.52

Table 32

Dose rate at R= 175 mm, Z= 3800 mm for exposure time T=10 years and different cooling time

Type	Element	Cooling time, t						
		1 d	3 d	5 d	7 d	15 d	30 d	100 d
Hadron activation	ID beam pipe	13.70	7.75	7.06	6.91	6.82	6.59	6.18
	LAr beam pipe	1360.	1150.	1000.	894.	637.	441.	230.
	Pixel type 2 services	7.76	6.01	5.55	5.30	4.71	4.11	2.84
	Pixel	19.70	13.70	12.50	11.90	10.60	9.36	7.17
	SCT barrel	0.23	0.17	0.16	0.15	0.14	0.13	0.10
	SCT forward	1.00	0.66	0.60	0.59	0.55	0.52	0.43
	SCT barrel services	2.22	1.90	1.76	1.66	1.42	1.17	0.66
	SCT forward services	2.93	2.52	2.33	2.19	1.85	1.51	0.84
	TRT	1.64	1.07	0.96	0.92	0.83	0.76	0.66
	TRT services	2.23	1.86	1.68	1.55	1.22	0.96	0.57
	LAr Barrel	15.20	11.80	9.51	8.06	5.96	5.60	5.22
	LAr EndCap	37.00	25.30	21.30	18.80	13.90	9.46	7.04
Neutron activation	ID beam pipe	0.26	0.03	0.01	0.01	0.01	0.01	0.00
	LAr beam pipe	74.7	73.1	72.2	71.4	68.9	64.9	53.3
	Pixel type 2 services	8.14	2.92	2.52	2.49	2.46	2.41	2.24
	Pixel	4.56	0.43	0.11	0.08	0.07	0.07	0.06
	SCT barrel	0.15	0.07	0.06	0.05	0.05	0.04	0.04
	SCT forward	0.63	0.38	0.32	0.29	0.25	0.24	0.20
	SCT barrel services	7.85	1.59	1.14	1.10	1.09	1.07	1.00
	SCT forward services	8.02	1.59	1.11	1.08	1.06	1.04	0.98
	TRT	2.41	0.91	0.51	0.35	0.17	0.14	0.12
	TRT services	5.09	1.00	0.70	0.67	0.65	0.63	0.56
	LAr Barrel	15.9	1.88	1.72	1.69	1.62	1.41	1.30
	LAr EndCap	5.03	4.28	3.06	2.94	2.82	2.67	2.67
Total , μ Sv/h		1596.35	1310.92	1146.87	1034.18	764.15	555.8	324.18

Table 33

Dose rate at R= 400 mm, Z= 3800 mm for exposure time T=100 days and different cooling time

Type	Element	Cooling time, t						
		1 d	3 d	5 d	7 d	15 d	30 d	100 d
Hadron activation	ID beam pipe	2.91	0.96	0.72	0.68	0.62	0.57	0.48
	LAr beam pipe	358.	297.	256.	225.	151.	97.4	44.2
	Pixel type 2 services	6.15	4.36	3.89	3.64	3.06	2.51	1.42
	Pixel	11.40	6.71	5.74	5.29	4.31	3.44	2.03
	SCT barrel	0.15	0.09	0.08	0.07	0.06	0.05	0.03
	SCT forward	0.64	0.30	0.25	0.24	0.21	0.18	0.12
	SCT barrel services	1.94	1.62	1.48	1.38	1.15	0.92	0.47
	SCT forward services	2.54	2.13	1.94	1.81	1.49	1.18	0.59
	TRT	1.12	0.54	0.43	0.39	0.31	0.25	0.17
	TRT services	1.99	1.61	1.43	1.29	0.97	0.72	0.37
	LAr Barrel	11.5	7.32	5.70	4.78	2.85	1.66	1.42
	LAr EndCap	27.0	16.4	13.5	11.7	8.20	5.66	2.61
Neutron activation	ID beam pipe	0.08	0.01	0.00	0.00	0.00	0.00	0.00
	LAr beam pipe	9.27	8.91	8.70	8.52	7.89	6.94	4.16
	Pixel type 2 services	6.50	1.03	0.62	0.59	0.57	0.53	0.42
	Pixel	3.81	0.33	0.06	0.03	0.03	0.02	0.02
	SCT barrel	0.12	0.05	0.04	0.03	0.02	0.02	0.02
	SCT forward	0.49	0.25	0.19	0.17	0.13	0.12	0.10
	SCT barrel services	7.07	0.74	0.28	0.24	0.23	0.22	0.18
	SCT forward services	7.23	0.75	0.27	0.24	0.23	0.21	0.17
	TRT	2.33	0.83	0.44	0.27	0.10	0.07	0.06
	TRT services	4.74	0.53	0.23	0.20	0.18	0.16	0.11
	LAr Barrel	12.6	0.87	0.61	0.58	0.53	0.42	0.33
	LAr EndCap	3.64	0.81	0.54	0.44	0.42	0.41	0.40
Total , $\mu\text{Sv/h}$		483.22	354.15	303.14	267.58	184.56	123.66	59.88

Table 34

Dose rate at R= 400 mm, Z= 3800 mm for exposure time T=10 years and different cooling time

Type	Element	Cooling time, t						
		1 d	3 d	5 d	7 d	15 d	30 d	100 d
Hadron activation	ID beam pipe	4.69	2.68	2.44	2.39	2.36	2.27	2.11
	LAr beam pipe	391.	329.	288.	257.	183.	127.	66.5
	Pixel type 2 services	8.01	6.21	5.73	5.47	4.86	4.25	2.93
	Pixel	15.70	10.90	9.95	9.49	8.46	7.50	5.76
	SCT barrel	0.23	0.17	0.15	0.15	0.14	0.12	0.10
	SCT forward	0.97	0.63	0.58	0.57	0.53	0.50	0.42
	SCT barrel services	2.25	1.92	1.78	1.68	1.44	1.19	0.67
	SCT forward services	2.93	2.52	2.32	2.19	1.85	1.52	0.84
	TRT	1.66	1.08	0.97	0.93	0.84	0.77	0.67
	TRT services	2.30	1.92	1.73	1.59	1.26	0.99	0.58
	LAr Barrel	14.2	10.7	8.61	7.30	4.76	4.62	4.40
	LAr EndCap	32.1	23.2	19.4	17.2	12.7	8.29	6.22
Neutron activation	ID beam pipe	0.08	0.01	0.00	0.00	0.00	0.00	0.00
	LAr beam pipe	18.5	18.1	17.8	17.6	16.9	15.8	12.4
	Pixel type 2 services	8.53	3.05	2.64	2.60	2.57	2.52	2.35
	Pixel	3.85	0.36	0.09	0.07	0.06	0.06	0.05
	SCT barrel	0.14	0.07	0.06	0.05	0.05	0.04	0.04
	SCT forward	0.61	0.36	0.31	0.28	0.25	0.23	0.19
	SCT barrel services	7.95	1.61	1.15	1.11	1.10	1.08	1.01
	SCT forward services	8.08	1.60	1.12	1.09	1.07	1.05	0.99
	TRT	2.40	0.90	0.51	0.35	0.17	0.14	0.12
	TRT services	5.23	1.03	0.72	0.69	0.67	0.65	0.58
	LAr Barrel	13.20	1.90	1.74	1.71	1.64	1.44	1.33
	LAr EndCap	4.51	3.56	2.49	2.45	2.37	2.06	2.01
Total , $\mu\text{Sv/h}$		549.12	423.48	370.29	333.96	249.05	184.09	112.27

Table 35

Dose rate at R= 700 mm, Z= 3800 mm for exposure time T=100 days and different cooling time

Type	Element	Cooling time, t						
		1 d	3 d	5 d	7 d	15 d	30 d	100 d
Hadron activation	ID beam pipe	1.13	0.39	0.30	0.29	0.26	0.24	0.19
	LAr beam pipe	172.	142.	123.	108.	72.7	47.0	21.5
	Pixel type 2 services	5.21	3.70	3.31	3.09	2.61	2.14	1.21
	Pixel	7.58	4.45	3.80	3.50	2.86	2.29	1.35
	SCT barrel	0.15	0.09	0.07	0.07	0.06	0.05	0.03
	SCT forward	0.58	0.28	0.23	0.22	0.19	0.16	0.11
	SCT barrel services	1.99	1.66	1.52	1.42	1.18	0.95	0.48
	SCT forward services	2.52	2.12	1.93	1.80	1.48	1.17	0.59
	TRT	1.12	0.54	0.43	0.39	0.31	0.25	0.18
	TRT services	2.14	1.73	1.53	1.39	1.04	0.77	0.39
	LAr Barrel	10.5	6.69	5.21	4.37	2.61	1.67	1.43
	LAr EndCap	21.8	12.9	10.6	9.21	6.44	4.33	2.00
Neutron activation	ID beam pipe	0.03	0.00	0.00	0.00	0.00	0.00	0.00
	LAr beam pipe	4.78	4.62	4.52	4.43	4.10	3.60	2.10
	Pixel type 2 services	6.05	0.96	0.57	0.54	0.52	0.49	0.39
	Pixel	2.63	0.23	0.04	0.03	0.02	0.02	0.01
	SCT barrel	0.12	0.05	0.04	0.03	0.02	0.02	0.02
	SCT forward	0.45	0.23	0.18	0.15	0.12	0.11	0.09
	SCT barrel services	7.25	0.76	0.28	0.25	0.24	0.22	0.18
	SCT forward services	7.33	0.76	0.28	0.24	0.23	0.22	0.17
	TRT	2.25	0.79	0.42	0.26	0.10	0.07	0.06
	TRT services	5.09	0.57	0.24	0.21	0.20	0.18	0.12
	LAr Barrel	10.9	0.69	0.48	0.46	0.42	0.40	0.31
	LAr EndCap	2.33	0.78	0.52	0.39	0.38	0.37	0.35
Total , μ Sv/h		275.93	186.99	159.5	140.74	98.09	66.72	33.26

Table 36

Dose rate at R= 700 mm, Z= 3800 mm for exposure time T=10 years and different cooling time

Type	Element	Cooling time, t						
		1 d	3 d	5 d	7 d	15 d	30 d	100 d
Hadron activation	ID beam pipe	1.81	1.05	0.96	0.94	0.92	0.89	0.81
	LAr beam pipe	188.	158.	138.	123.	88.1	61.3	32.3
	Pixel type 2 services	6.79	5.27	4.86	4.64	4.13	3.61	2.49
	Pixel	10.40	7.25	6.60	6.29	5.62	4.98	3.82
	SCT barrel	0.22	0.16	0.15	0.14	0.13	0.12	0.10
	SCT forward	0.88	0.58	0.53	0.52	0.49	0.45	0.38
	SCT barrel services	2.31	1.98	1.83	1.73	1.48	1.22	0.69
	SCT forward services	2.91	2.50	2.31	2.18	1.84	1.51	0.84
	TRT	1.67	1.09	0.98	0.94	0.85	0.79	0.68
	TRT services	2.47	2.06	1.86	1.71	1.35	1.06	0.63
	LAr Barrel	14.2	10.6	8.61	7.30	4.74	4.51	4.39
	LAr EndCap	26.1	18.0	15.1	13.4	9.91	7.77	5.83
Neutron activation	ID beam pipe	0.03	0.00	0.00	0.00	0.00	0.00	0.00
	LAr beam pipe	8.48	8.30	8.18	8.08	7.70	7.11	5.30
	Pixel type 2 services	7.94	2.84	2.46	2.43	2.40	2.35	2.19
	Pixel	2.66	0.26	0.07	0.05	0.05	0.05	0.04
	SCT barrel	0.14	0.07	0.06	0.05	0.05	0.04	0.04
	SCT forward	0.56	0.33	0.28	0.26	0.23	0.21	0.18
	SCT barrel services	8.14	1.65	1.18	1.14	1.12	1.10	1.03
	SCT forward services	8.20	1.62	1.14	1.10	1.09	1.07	1.00
	TRT	2.32	0.86	0.49	0.33	0.17	0.14	0.11
	TRT services	5.62	1.10	0.77	0.74	0.72	0.69	0.62
	LAr Barrel	12.3	1.71	1.57	1.54	1.48	1.42	1.31
	LAr EndCap	3.90	3.01	2.11	2.08	2.01	1.93	1.88
Total , μ Sv/h		318.05	230.29	200.1	180.59	136.58	104.32	66.66

Table37

Gamma dose rate ($\mu\text{Sv/h}$) along Z axis.

Results of the current study						
Distance from Barrel front surface Z_0 , cm	T= 180 d			T= 10 y		
	t= 1 d	t= 7 d	t= 30 d	t= 1 d	t= 7 d	t= 30 d
10	4.64	2.25	1.67	6.57	4.16	3.55
30	2.98	1.45	1.08	4.24	2.69	2.28
100	0.96	0.46	0.34	1.35	0.86	0.73
Results of the study by C.Buttar et al.						
Distance from Barrel front surface Z_0 , cm	T= 180 d			T= 10 y		
	t= 1 d	t= 7 d	t= 30 d	t= 1 d	t= 7 d	t= 30 d
10	7.15	2.78	2.28	9.77	5.37	4.79
30	4.59	1.78	1.46	6.27	3.45	3.07
100	1.44	0.56	0.46	1.96	1.08	0.96

Table 38

Gamma dose rate ($\mu\text{Sv/h}$) along R axis.

Results of the current study						
Distance from Barrel cylindrical surface R_0 , cm	T= 180 d			T= 10 y		
	t= 1 d	t= 7 d	t= 30 d	t= 1 d	t= 7 d	t= 30 d
10	7.09	3.43	2.56	10.04	6.36	5.41
30	3.97	1.92	1.44	5.63	3.57	3.04
100	1.19	0.57	0.43	1.67	1.06	0.91
Results of the study by C.Buttar et al.						
Distance from Barrel cylindrical surface R_0 , cm	T= 180 d			T= 10 y		
	t= 1 d	t= 7 d	t= 30 d	t= 1 d	t= 7 d	t= 30 d
10	10.53	4.09	3.36	14.39	7.91	7.06
30	5.85	2.28	1.87	8	4.39	3.92
100	1.72	0.67	0.55	2.35	1.29	1.15

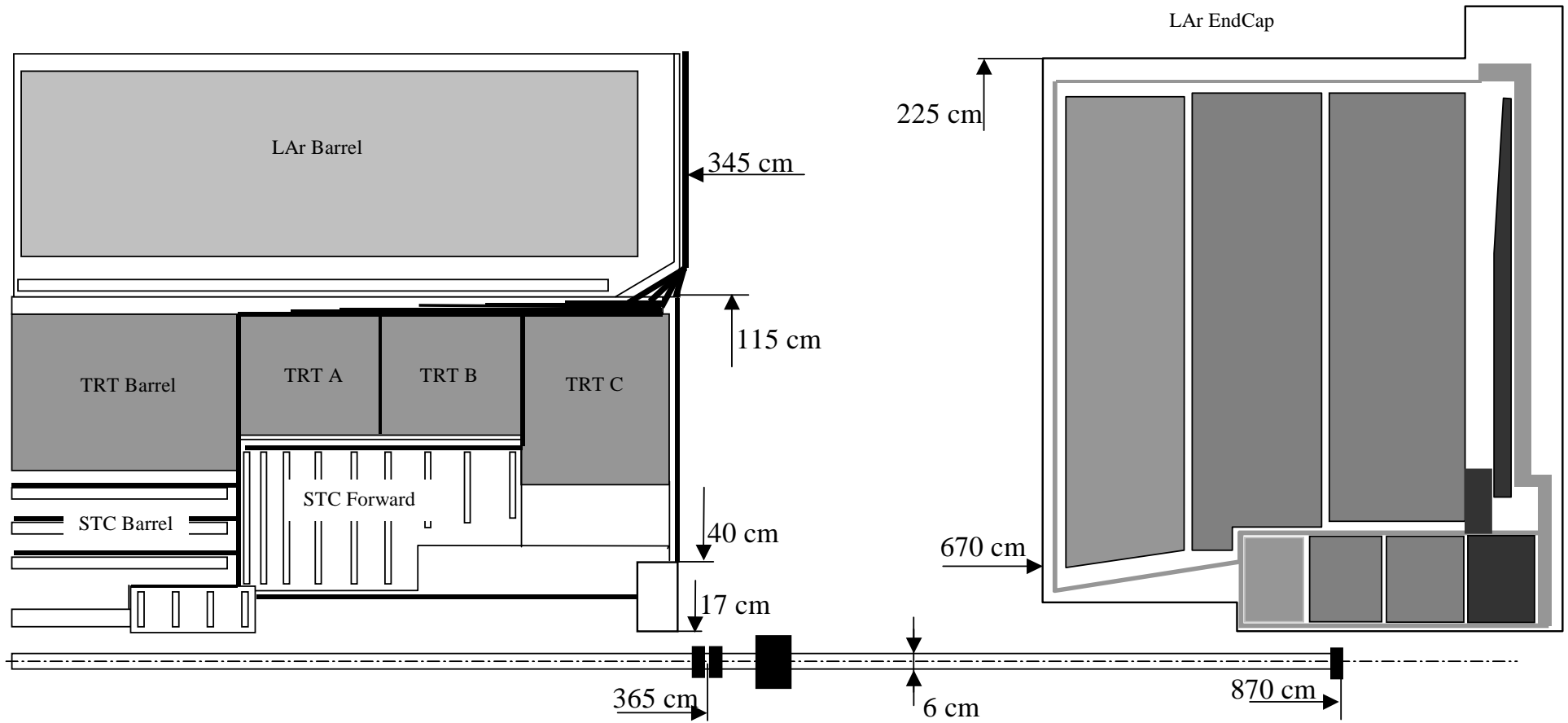

Fig. A1.1 General detector opening layout to calculations of access dose rate.

Table A1.1

Equivalent dose rate in the general access scenario for T= 100 d, t= 1 d

R/Z, cm	dR\dZ	340	340- 350	350- 365	365- 380	380- 405	405- 430	430- 480	480- 530	530- 580	580- 605	605- 630	630- 645	645- 660	660- 670	670
		0	10	15	15	25	25	50	50	50	25	25	15	15	10	0
0- 5	5															
5- 10	5	651.6	708.3	1467.5	5187.3	3028.1	2058.4	2705.9	4254.7	3855.2	3433.1	3265.1	3221.1	3269.1	3289.5	1955.6
10- 20	10	583.1	615.1	922.7	1651.9	1428.1	1110.4	1357.2	1943.2	1848.1	1697.5	1648.9	1664.1	1718.5	1776.1	1165.1
20- 30	10	487.3	507.1	624.2	810.3	808.6	725.0	841.2	1105.0	1097.6	1042.8	1036.1	1065.2	1109.1	1175.8	837.4
30- 45	15	423.0	430.9	450.9	505.2	523.2	513.0	574.7	705.8	722.9	708.2	715.9	744.0	784.8	838.1	618.2
45- 60	15	369.6	372.0	347.6	360.3	372.6	380.7	416.8	486.6	509.3	514.0	522.9	544.3	570.1	602.9	446.1
60- 75	15	304.6	305.7	286.3	287.1	293.9	302.2	326.8	369.3	390.4	398.1	405.2	417.6	428.6	441.4	316.7
75- 95	20	258.1	256.7	240.5	236.9	237.1	244.0	260.3	285.9	302.5	310.7	310.8	314.5	316.5	314.2	214.9
95- 115	20	246.7	236.2	209.1	198.8	196.1	199.6	209.8	224.7	237.7	239.7	236.7	233.4	231.5	224.3	145.4
115- 125	10	229.7	221.1	188.7	176.9	173.5	175.5	181.8	192.4	201.4	201.0	196.1	189.5	187.8	179.5	112.3
125- 150	25	181.1	175.4	161.4	155.0	151.7	152.5	156.7	163.9	167.6	167.3	158.3	152.7	150.6	143.2	86.6
150- 175	25	140.7	137.9	130.3	127.6	125.9	125.5	128.2	132.5	133.1	129.9	119.6	115.9	113.8	107.5	62.4
175- 200	25	111.8	110.3	107.0	105.8	104.6	104.7	106.5	109.1	107.6	103.4	93.0	91.1	88.6	82.8	45.4
200- 225	25	91.3	89.6	87.8	87.2	86.6	87.2	90.4	90.5	88.2	83.3	74.3	74.0	70.4	65.5	34.4

Table A1.1

Equivalent dose rate in the general access scenario for T= 100 d, t= 5 d

R/Z, cm	dR\dZ	340	340- 350	350- 365	365- 380	380- 405	405- 430	430- 480	480- 530	530- 580	580- 605	605- 630	630- 645	645- 660	660- 670	670
		0	10	15	15	25	25	50	50	50	25	25	15	15	10	0
0- 5	5															
5- 10	5	374.5	417.8	955.8	3666.4	2137.8	1444.4	1914.9	3041.8	2754.6	2436.4	2293.9	2234.1	2234.0	2214.1	1236.1
10- 20	10	327.5	360.3	591.7	1130.5	984.1	763.3	945.5	1374.5	1299.8	1179.6	1127.5	1112.5	1118.2	1124.1	670.8
20- 30	10	269.6	289.9	386.7	531.6	539.9	486.4	575.4	769.0	758.5	707.7	687.8	685.5	691.6	700.7	439.6
30- 45	15	224.9	234.9	266.1	314.7	336.0	335.2	385.3	481.7	489.2	468.8	462.0	464.7	473.6	486.0	317.9
45- 60	15	187.2	192.3	194.6	213.2	229.7	241.4	272.8	324.6	336.4	332.1	329.8	333.9	340.0	348.7	231.9
60- 75	15	150.3	153.0	154.2	162.9	175.1	186.8	209.1	241.1	252.7	252.4	252.6	254.2	256.3	258.8	168.9
75- 95	20	123.2	124.4	124.3	129.3	136.7	146.6	162.6	182.7	192.0	194.5	192.4	191.7	190.9	188.0	118.0
95- 115	20	109.4	108.3	104.2	105.2	109.8	117.3	127.7	140.3	148.5	148.1	146.4	143.3	140.9	137.0	82.5
115- 125	10	100.0	98.6	92.5	92.4	95.7	100.7	108.9	118.8	124.8	123.7	121.4	117.2	115.3	111.1	64.7
125- 150	25	82.5	81.8	80.2	80.6	82.7	86.4	92.3	99.7	103.0	102.8	98.3	95.3	93.1	89.4	50.9
150- 175	25	67.4	66.8	66.6	67.0	68.3	70.7	75.1	79.4	80.8	79.7	75.0	72.9	71.1	68.1	37.8
175- 200	25	56.5	55.8	56.1	56.5	57.6	58.9	61.8	64.6	64.8	62.9	58.9	57.3	55.7	53.5	28.5
200- 225	25	47.7	47.1	47.7	48.1	48.1	49.3	51.8	53.5	53.0	51.0	47.3	46.5	44.7	43.1	22.2

Table A1.1 (continuation)

Equivalent dose rate in the general access scenario for T= 100 d, t=100d

R/Z, cm	dR\dZ	340	340-	350-	365-	380-	405-	430-	480-	530-	580-	605-	630-	645-	660-	670	
		0	350	365	380	405	430	480	530	580	605	630	645	660	670	0	
0- 5	5																
5- 10	5	82.4	89.6	186.7	681.6	388.4	260.8	361.7	604.5	540.2	467.4	436.5	426.5	429.7	431.2	253.6	
10- 20	10	73.1	77.0	116.1	212.6	182.2	140.9	180.4	272.5	255.2	227.7	217.4	215.9	221.3	229.5	148.7	
20- 30	10	59.9	62.6	77.7	102.4	102.3	91.9	110.9	152.4	149.1	137.0	133.3	134.3	138.4	146.3	101.3	
30- 45	15	52.0	53.0	55.3	62.7	65.5	64.7	75.2	95.1	96.1	90.9	89.4	90.6	93.5	98.0	67.6	
45- 60	15	45.2	45.6	42.0	43.8	46.0	47.6	53.8	63.8	65.6	63.9	63.7	64.5	65.9	67.7	45.7	
60- 75	15	35.9	36.4	33.7	34.3	35.8	37.0	41.3	47.0	49.2	48.8	48.4	48.8	49.2	49.5	32.4	
75- 95	20	29.2	29.5	27.5	27.5	28.3	29.4	32.3	35.9	37.3	37.3	37.0	36.5	36.5	36.0	22.5	
95- 115	20	26.2	25.7	23.6	22.6	23.0	23.7	25.7	27.8	28.7	28.6	28.1	27.3	27.3	26.4	15.6	
115- 125	10	24.4	23.6	20.9	20.1	20.0	20.7	21.9	23.6	24.2	23.9	23.3	22.5	22.3	21.4	12.4	
125- 150	25	19.8	19.1	18.0	17.6	17.5	18.0	18.8	19.7	19.9	19.7	19.1	18.3	18.3	17.4	9.8	
150- 175	25	15.7	15.3	14.7	14.6	14.5	14.8	15.2	15.7	15.7	15.5	14.5	14.2	14.1	13.3	7.2	
175- 200	25	13.1	12.9	12.2	12.1	12.2	12.0	12.7	12.9	12.7	12.4	11.4	11.4	11.1	10.6	5.5	
200- 225	25	10.9	10.6	10.4	10.1	10.1	10.4	10.9	10.5	10.5	10.0	9.3	9.4	9.0	8.5	4.2	

Table A1.1 (continuation)

Equivalent dose rate in the general access scenario for T= 10y, t= 1d

R/Z, cm	dR\ dZ	340	340- 350	350- 365	365- 380	380- 405	405- 430	430- 480	480- 530	530- 580	580- 605	605- 630	630- 645	645- 660	660- 670	670
		0	10	15	15	25	25	50	50	50	25	25	15	15	10	0
0- 5	5															
5- 10	5	765.8	829.8	1686.3	5890.6	3388.9	2295.7	3008.1	4706.0	4264.5	3808.3	3634.4	3599.2	3673.7	3719.0	2254.7
10- 20	10	686.7	717.7	1057.4	1872.6	1606.9	1243.8	1512.3	2160.0	2052.8	1896.4	1853.1	1883.6	1962.2	2055.7	1390.8
20- 30	10	571.5	590.4	717.7	922.8	914.2	815.9	941.2	1231.5	1226.0	1173.0	1175.8	1219.7	1286.9	1391.5	1033.4
30- 45	15	497.8	505.0	520.7	577.5	594.4	579.6	646.3	790.5	812.8	803.2	819.2	859.7	916.6	993.6	758.4
45- 60	15	437.5	439.1	403.5	413.5	425.0	432.4	470.9	548.1	575.5	586.0	602.0	632.7	668.0	710.1	539.1
60- 75	15	358.8	359.2	332.8	330.5	336.1	343.9	370.3	417.4	444.1	457.0	467.2	485.2	502.5	517.3	378.3
75- 95	20	302.8	300.9	279.5	272.8	273.1	278.6	296.6	325.1	346.2	357.3	359.7	365.3	369.8	368.6	258.5
95- 115	20	287.3	275.3	242.6	229.5	225.7	229.5	240.1	256.7	272.2	276.9	273.9	270.3	269.7	261.9	173.6
115- 125	10	268.1	257.2	219.0	205.4	200.5	201.8	208.9	220.3	231.3	232.3	226.3	219.4	218.4	208.9	133.5
125- 150	25	212.7	205.3	188.0	180.0	176.3	176.2	180.1	187.9	193.5	193.2	182.6	176.1	174.9	165.5	102.5
150- 175	25	165.9	162.0	153.2	149.4	146.7	145.6	147.5	152.4	153.6	150.8	137.3	133.4	131.7	123.0	72.9
175- 200	25	133.3	130.3	126.1	124.2	122.4	121.1	123.2	126.1	124.2	119.1	106.2	105.0	101.5	93.9	52.7
200- 225	25	108.6	106.1	103.8	102.4	101.1	101.5	104.7	104.7	102.0	95.6	84.8	84.9	79.7	73.8	39.5

Table A1.1 (continuation)

Equivalent dose rate in the general access scenario for T= 10y, t= 5 d

R/Z, cm	dR\dZ	340	340- 350	350- 365	365- 380	380- 405	405- 430	430- 480	480- 530	530- 580	580- 605	605- 630	630- 645	645- 660	660- 670	670
		0	10	15	15	25	25	50	50	50	25	25	15	15	10	0
0- 5	5															
5- 10	5	486.9	537.5	1173.8	4354.2	2490.3	1677.0	2209.4	3490.9	3153.6	2793.5	2646.6	2598.3	2625.2	2628.5	1529.5
10- 20	10	431.1	461.1	724.3	1348.0	1160.7	893.6	1097.3	1583.8	1501.1	1370.0	1324.9	1326.5	1359.1	1398.2	895.1
20- 30	10	353.1	372.4	478.1	641.3	643.7	575.8	673.6	894.0	884.4	833.7	822.9	837.5	866.1	912.3	632.0
30- 45	15	298.8	308.2	334.6	385.7	405.8	400.7	455.2	565.4	577.1	560.7	562.0	578.6	604.6	638.9	453.4
45- 60	15	254.4	258.3	249.6	265.5	280.9	292.5	325.9	385.2	401.9	402.2	407.2	419.5	436.5	455.4	327.3
60- 75	15	203.3	206.3	199.8	206.1	216.7	228.1	252.0	288.6	305.2	309.8	314.0	320.8	328.2	335.0	231.5
75- 95	20	167.4	168.2	162.5	165.2	171.5	180.5	198.2	221.1	234.7	240.2	240.7	241.9	243.2	241.3	160.6
95- 115	20	150.0	146.8	137.4	135.7	139.0	146.0	157.5	172.0	182.8	185.0	183.2	180.1	179.2	173.8	110.3
115- 125	10	137.9	134.9	123.2	120.3	122.5	127.0	135.5	146.1	154.3	154.7	151.6	146.6	145.5	139.5	85.7
125- 150	25	114.3	111.6	106.5	105.5	106.4	109.6	115.5	123.1	128.0	128.5	122.2	118.5	117.1	111.7	66.5
150- 175	25	93.0	91.2	88.8	88.1	88.6	90.4	94.2	99.4	100.7	99.8	92.6	90.2	88.7	84.2	48.1
175- 200	25	77.1	75.6	75.3	75.0	74.8	75.4	78.3	81.5	81.1	79.0	72.0	71.0	69.0	64.9	35.6
200- 225	25	65.3	63.8	63.1	63.0	62.5	63.5	66.1	67.4	66.7	63.2	57.6	57.5	54.6	51.0	26.9

Table A1.1 (continuation)

Equivalent dose rate in the general access scenario for T= 10y, t= 100 d

R/Z, cm	dR\dZ	340	340- 350	350- 365	365- 380	380- 405	405- 430	430- 480	480- 530	530- 580	580- 605	605- 630	630- 645	645- 660	660- 670	670
		0	10	15	15	25	25	50	50	50	25	25	15	15	10	0
0- 5	5															
5- 10	5	177.3	189.7	361.4	1222.2	659.7	434.7	576.3	920.9	822.6	725.9	694.7	700.6	729.2	753.2	491.2
10- 20	10	160.4	161.4	223.7	384.8	318.2	240.7	293.4	424.2	400.6	370.0	367.2	383.4	413.7	453.9	340.1
20- 30	10	129.8	131.0	152.4	190.1	183.3	160.9	184.8	243.9	242.4	234.3	239.3	256.6	282.8	327.3	276.0
30- 45	15	113.8	114.2	111.8	120.1	120.7	116.1	128.7	157.7	163.0	163.5	169.8	184.4	203.6	229.8	190.8
45- 60	15	102.2	101.9	87.4	86.8	87.5	87.9	94.9	110.5	116.8	120.8	126.8	136.5	147.5	159.3	128.1
60- 75	15	81.4	81.5	71.9	69.5	69.8	70.6	75.2	84.7	91.0	96.0	98.9	104.7	110.3	114.7	89.3
75- 95	20	66.6	66.4	59.6	57.4	56.6	57.0	60.5	66.6	72.1	75.0	76.7	78.3	80.9	81.1	60.5
95- 115	20	60.5	58.7	51.5	48.2	47.1	47.4	49.7	53.4	56.8	58.6	58.1	57.9	58.9	57.1	40.4
115- 125	10	56.8	54.3	46.2	43.4	42.1	42.2	43.9	45.8	48.6	49.3	48.0	46.8	47.5	45.0	30.8
125- 150	25	46.2	44.7	40.5	38.2	37.5	37.1	38.0	39.1	41.2	40.8	38.5	37.4	38.0	35.1	23.4
150- 175	25	37.0	36.0	33.9	32.8	32.0	31.4	31.1	32.4	32.8	32.0	28.7	28.3	28.2	25.5	16.3
175- 200	25	30.7	29.8	28.5	27.6	27.0	25.8	26.7	27.2	26.4	25.3	21.8	22.2	21.2	19.1	11.5
200- 225	25	25.9	24.8	23.9	23.2	22.4	22.4	22.7	22.5	21.7	19.8	17.1	17.7	16.3	14.7	8.2

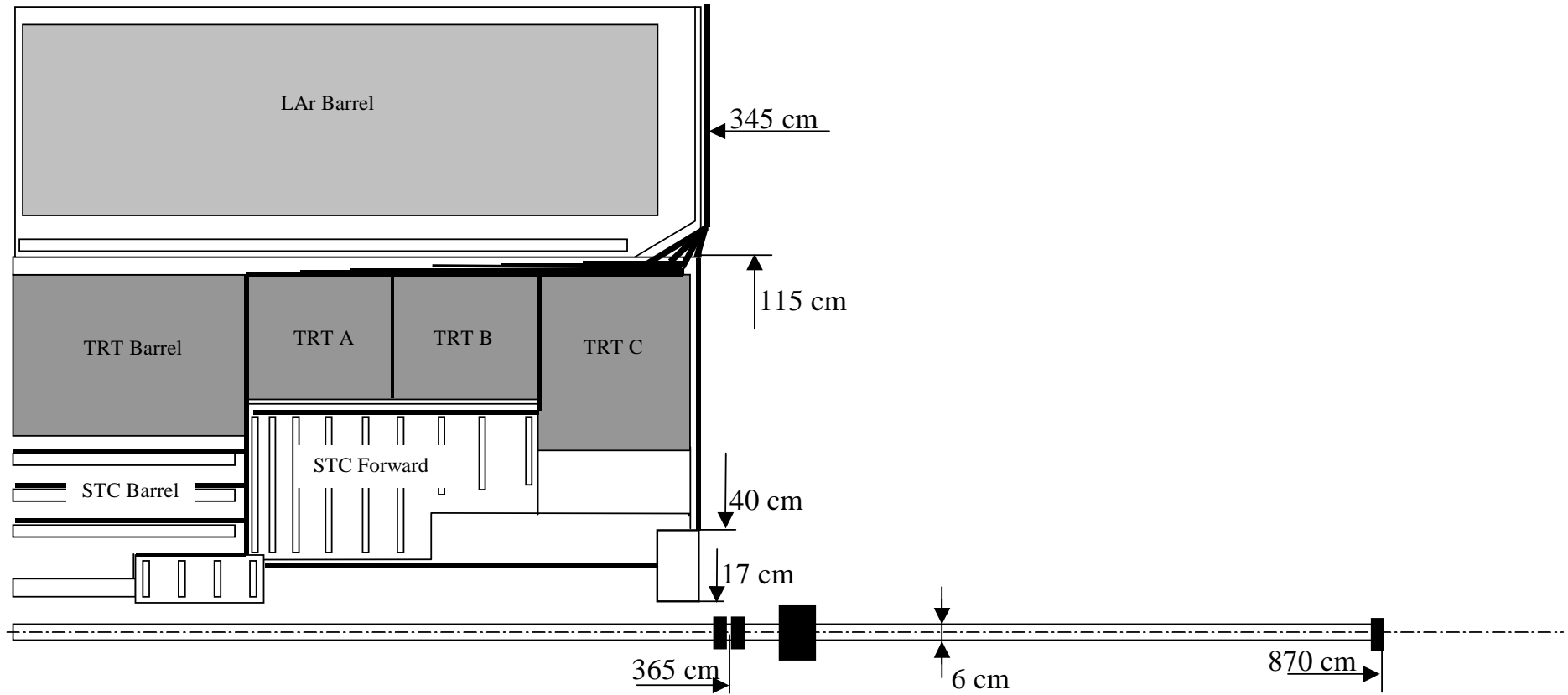

Fig. A1.2. Detector opening layout to calculations of access dose rate -- Lar EndCap removed.

Table A1.2

Equivalent dose rate in the ID access scenario for T= 100 d, t= 1 d -- Lar EndCap removed

R/Z, cm	dR\dZ	340	340- 350	350- 365	365- 380	380- 405	405- 430	430- 480	480- 530	530- 580	580- 605	605- 630	630- 645	645- 660	660- 670	670
		0	10	15	15	25	25	50	50	50	25	25	15	15	10	0
0- 5	5															
5- 10	5	620.9	677.2	1434.6	5152.0	2989.4	2014.8	2652.4	4180.6	3743.5	3262.9	3022.2	2892.9	2839.9	2733.4	1356.4
10- 20	10	553.7	585.4	891.2	1618.1	1391.1	1068.7	1306.0	1871.9	1739.2	1534.3	1426.6	1364.0	1328.8	1282.0	635.8
20- 30	10	459.9	479.2	594.7	778.7	773.9	686.0	793.3	1038.2	994.6	893.2	832.5	795.9	770.1	746.4	370.7
30- 45	15	398.0	405.5	424.1	476.6	491.9	477.9	531.6	645.6	631.6	577.7	539.7	516.2	499.0	484.2	240.7
45- 60	15	347.0	349.1	323.6	334.7	344.8	349.3	378.1	432.2	428.2	398.0	372.4	357.2	345.3	335.5	167.0
60- 75	15	284.0	284.9	264.5	263.9	268.6	273.7	291.1	319.2	316.9	298.2	279.7	268.9	260.2	253.2	126.1
75- 95	20	239.5	238.0	221.0	216.1	214.5	217.9	227.1	240.7	239.3	227.0	212.9	205.3	199.2	194.0	96.7
95- 115	20	230.5	219.8	191.6	179.9	175.0	175.1	179.5	185.6	183.8	175.1	164.1	159.1	154.8	150.7	75.1
115- 125	10	214.6	205.6	172.0	158.7	153.1	152.0	153.9	156.9	154.8	148.1	138.8	134.4	131.2	127.9	63.8
125- 150	25	166.0	160.3	145.0	137.2	132.0	130.6	131.7	132.3	129.8	124.5	116.4	113.0	110.2	108.1	53.8
150- 175	25	125.8	122.7	114.3	110.8	108.0	106.6	107.1	106.7	104.5	100.0	93.0	90.7	88.7	87.2	43.2
175- 200	25	97.7	96.1	92.5	91.0	89.4	89.2	89.0	88.4	86.2	82.5	76.5	74.5	73.4	72.1	35.6
200- 225	25	79.0	77.5	75.8	75.4	74.9	74.7	74.8	74.1	72.3	69.4	64.2	62.8	61.9	60.6	30.1

Table A1.2

Equivalent dose rate in the ID access scenario for T= 100 d, t= 5 d -- Lar EndCap removed

R/Z, cm	dR\vdZ	340	340- 350	350- 365	365- 380	380- 405	405- 430	430- 480	480- 530	530- 580	580- 605	605- 630	630- 645	645- 660	660- 670	670
		0	10	15	15	25	25	50	50	50	25	25	15	15	10	0
0- 5	5															
5- 10	5	359.9	403.1	940.3	3649.7	2119.6	1423.8	1889.9	3007.4	2703.1	2358.4	2184.9	2091.0	2052.1	1981.3	982.5
10- 20	10	313.7	346.1	576.7	1114.5	966.5	743.5	921.3	1341.1	1249.3	1105.7	1029.7	984.3	957.1	926.1	460.1
20- 30	10	256.5	276.5	372.5	516.5	523.4	467.8	552.6	737.6	710.9	640.5	599.3	572.3	554.3	537.1	266.4
30- 45	15	213.0	222.8	253.3	301.2	321.2	318.6	365.2	453.8	448.1	411.9	386.9	370.0	357.8	347.4	172.4
45- 60	15	176.7	181.6	183.4	201.2	216.7	226.8	254.9	299.9	300.6	281.6	265.6	254.7	246.6	239.6	118.8
60- 75	15	140.7	143.3	144.1	152.2	163.5	173.6	192.7	218.5	220.4	209.2	198.5	190.8	185.0	180.3	89.4
75- 95	20	114.7	115.8	115.3	119.8	126.3	134.6	147.5	162.5	164.4	157.8	150.2	144.8	141.0	137.3	68.1
95- 115	20	101.9	100.6	96.1	96.5	100.0	106.0	114.1	123.1	124.6	120.2	115.1	111.5	108.6	106.1	52.7
115- 125	10	92.9	91.3	84.7	84.0	86.3	90.2	96.6	103.1	104.2	101.0	96.6	93.9	91.7	89.6	44.4
125- 150	25	75.6	74.8	72.7	72.6	73.9	76.8	81.4	85.5	86.5	84.2	80.4	78.5	76.6	74.9	37.2
150- 175	25	60.8	60.1	59.6	59.7	60.5	62.4	65.5	68.0	68.5	66.9	63.7	62.4	61.0	59.8	29.8
175- 200	25	50.4	49.6	49.8	50.0	50.8	51.8	53.9	55.6	55.6	54.3	52.0	50.8	49.8	49.0	24.4
200- 225	25	42.2	41.6	42.2	42.6	42.7	43.6	45.0	46.4	46.3	45.3	43.1	42.3	41.6	41.1	20.4

Table A1.2 (continuation)
 Equivalent dose rate in the ID access scenario for T= 100 d, t= 100 d-- Lar EndCap removed

R/Z, cm	dR\ dZ	340	340- 350	350- 365	365- 380	380- 405	405- 430	430- 480	480- 530	530- 580	580- 605	605- 630	630- 645	645- 660	660- 670	670
		0	10	15	15	25	25	50	50	50	25	25	15	15	10	0
0- 5	5															
5- 10	5	79.5	86.7	183.5	678.2	384.7	256.5	356.3	596.8	528.0	448.5	408.9	387.6	377.1	362.0	179.1
10- 20	10	70.3	74.2	113.1	209.3	178.6	136.7	175.2	265.1	243.8	210.4	193.3	182.8	176.5	170.1	84.2
20- 30	10	57.2	59.8	74.8	99.3	98.8	88.0	106.0	145.5	138.7	122.0	112.7	106.6	102.7	99.1	49.1
30- 45	15	49.5	50.5	52.6	59.8	62.4	61.1	70.8	89.2	87.4	78.6	72.9	69.2	66.5	64.3	31.7
45- 60	15	42.9	43.3	39.6	41.3	43.2	44.5	50.1	58.9	58.5	53.7	50.2	47.9	46.1	44.6	22.0
60- 75	15	33.9	34.4	31.6	32.1	33.4	34.4	38.2	42.8	42.9	40.0	37.6	36.0	34.7	33.7	16.6
75- 95	20	27.5	27.8	25.8	25.7	26.3	27.3	29.7	32.1	31.8	30.2	28.6	27.3	26.5	25.8	12.6
95- 115	20	24.9	24.4	22.2	21.2	21.3	21.8	23.1	24.4	24.2	23.1	21.9	21.1	20.6	20.0	9.7
115- 125	10	23.2	22.4	19.6	18.7	18.3	18.7	19.4	20.6	20.3	19.3	18.4	17.8	17.3	17.0	8.2
125- 150	25	18.6	17.9	16.7	16.1	15.8	16.1	16.6	17.2	16.7	16.1	15.5	14.9	14.6	14.3	6.9
150- 175	25	14.4	14.0	13.3	13.1	12.9	13.2	13.5	13.6	13.3	12.9	12.2	11.9	11.7	11.5	5.5
175- 200	25	11.8	11.6	10.9	10.9	11.0	10.8	11.3	11.1	10.9	10.6	10.0	9.8	9.6	9.5	4.6
200- 225	25	9.9	9.7	9.5	9.2	9.2	9.4	9.5	9.1	9.1	8.8	8.4	8.2	8.1	8.0	3.8

Table A1.2 (continuation)
 Equivalent dose rate in the ID access scenario for T= 10y, t= 1 d--- Lar EndCap removed

R/Z, cm	dR\vdZ	340	340- 350	350- 365	365- 380	380- 405	405- 430	430- 480	480- 530	530- 580	580- 605	605- 630	630- 645	645- 660	660- 670	670
		0	10	15	15	25	25	50	50	50	25	25	15	15	10	0
0- 5	5															
5- 10	5	728.0	791.3	1645.5	5847.0	3341.0	2241.7	2941.7	4613.3	4123.7	3593.7	3327.0	3179.4	3120.5	3004.8	1489.2
10- 20	10	650.7	681.0	1018.5	1830.9	1561.1	1192.2	1448.7	2071.0	1916.5	1691.4	1570.5	1499.0	1457.3	1409.5	698.3
20- 30	10	537.6	555.9	681.2	883.7	871.4	767.6	881.8	1148.3	1097.5	984.9	917.3	875.4	846.6	820.0	407.2
30- 45	15	466.8	473.5	487.5	542.1	555.6	536.0	592.7	715.3	698.1	637.8	594.8	568.0	548.8	532.3	264.3
45- 60	15	409.4	410.5	373.5	381.7	390.3	393.2	422.5	480.0	473.7	439.6	410.7	393.0	379.8	369.1	183.4
60- 75	15	333.1	333.2	305.5	301.6	304.6	308.4	325.8	354.8	351.9	330.2	308.6	296.1	286.8	279.0	138.7
75- 95	20	279.8	277.8	255.3	247.1	244.9	246.1	255.2	268.5	266.3	251.7	235.1	226.3	219.8	214.2	106.6
95- 115	20	267.2	254.9	221.0	206.2	199.5	198.9	202.1	207.3	204.4	194.6	181.5	175.3	170.8	166.7	83.0
115- 125	10	249.6	238.0	198.4	182.8	175.0	172.4	173.7	175.6	172.5	164.8	153.3	148.5	144.9	142.0	70.7
125- 150	25	194.3	186.4	167.7	157.7	151.5	148.6	148.6	148.3	145.3	138.7	128.8	124.9	121.9	119.7	59.5
150- 175	25	147.4	143.0	133.1	128.1	124.2	121.8	121.1	119.8	117.1	112.1	103.0	100.4	98.4	96.4	48.1
175- 200	25	115.5	112.4	107.8	105.6	103.5	101.9	101.1	99.6	96.9	92.1	84.8	82.9	81.2	79.6	39.6
200- 225	25	93.5	91.0	88.9	87.8	86.5	85.8	84.9	83.9	81.4	77.6	71.5	69.8	68.3	67.2	33.6

Table A1.2 (continuation)
 Equivalent dose rate in the ID access scenario for T= 10y, t= 5 d--- Lar EndCap removed

R/Z, cm	dR\vdZ	340	340- 350	350- 365	365- 380	380- 405	405- 430	430- 480	480- 530	530- 580	580- 605	605- 630	630- 645	645- 660	660- 670	670
		0	10	15	15	25	25	50	50	50	25	25	15	15	10	0
0- 5	5															
5- 10	5	465.2	515.4	1150.5	4329.3	2462.9	1646.2	2171.6	3438.0	3073.3	2671.8	2473.2	2363.9	2319.4	2237.4	1110.8
10- 20	10	410.4	440.0	701.9	1324.1	1134.4	864.0	1061.0	1533.0	1423.5	1254.7	1166.9	1113.7	1083.6	1046.8	519.3
20- 30	10	333.6	352.5	457.0	618.7	619.0	547.9	639.5	846.4	811.4	728.2	679.9	649.1	627.7	608.4	302.2
30- 45	15	281.0	290.1	315.5	365.3	383.5	375.7	424.6	522.6	512.8	469.3	439.6	420.0	405.9	393.6	195.6
45- 60	15	238.3	242.0	232.5	247.4	261.1	270.2	298.5	346.9	345.4	321.7	302.6	289.4	280.3	272.0	135.0
60- 75	15	188.9	191.5	184.3	189.7	198.9	208.0	226.9	253.6	254.2	239.9	226.4	217.3	210.9	205.3	101.8
75- 95	20	154.5	155.1	148.8	150.7	155.6	162.3	175.0	189.6	190.4	181.7	172.0	165.6	160.8	156.7	77.8
95- 115	20	138.7	135.4	125.2	122.6	124.2	128.8	136.4	144.6	145.0	139.4	132.2	127.7	124.6	121.6	60.3
115- 125	10	127.3	124.1	111.5	107.5	108.1	110.6	116.0	121.2	121.6	117.4	111.2	107.6	105.0	102.8	51.0
125- 150	25	103.9	101.0	95.0	93.0	92.7	94.3	98.0	101.0	101.3	98.2	92.5	90.1	88.1	86.4	42.7
150- 175	25	82.6	80.6	77.7	76.4	76.2	77.2	79.5	81.2	80.6	78.5	73.7	71.9	70.5	69.4	34.2
175- 200	25	67.3	65.8	65.2	64.7	64.3	64.6	65.9	66.8	66.0	64.1	60.3	58.9	58.0	56.9	28.2
200- 225	25	56.9	55.4	54.7	54.8	54.2	54.6	55.1	56.0	55.3	53.4	50.3	49.4	48.5	47.3	23.6

Table A1.2 (continuation)
 Equivalent dose rate in the ID access scenario for T= 10 y, t= 100 d-- Lar EndCap removed

R/Z, cm	dR\ dZ	340	340- 350	350- 365	365- 380	380- 405	405- 430	430- 480	480- 530	530- 580	580- 605	605- 630	630- 645	645- 660	660- 670	670
		0	10	15	15	25	25	50	50	50	25	25	15	15	10	0
0- 5	5															
5- 10	5	167.9	180.2	351.3	1211.3	647.7	421.2	559.3	896.5	784.4	667.3	609.3	579.5	564.1	542.1	268.8
10- 20	10	151.4	152.3	214.1	374.4	306.7	227.8	277.2	401.1	364.6	315.0	288.7	273.7	264.7	255.6	127.0
20- 30	10	121.3	122.3	143.2	180.3	172.5	148.6	169.7	222.5	209.1	184.2	168.8	160.1	154.4	149.2	74.3
30- 45	15	105.9	106.2	103.3	111.1	110.8	104.9	114.9	138.3	133.1	119.6	109.7	104.3	100.4	97.2	48.4
45- 60	15	95.0	94.6	79.7	78.6	78.5	77.8	82.5	93.2	90.6	82.7	76.0	72.3	69.8	67.7	33.9
60- 75	15	74.8	74.8	64.9	62.1	61.8	61.6	64.1	69.1	67.5	62.6	57.2	54.6	52.9	51.2	25.8
75- 95	20	60.9	60.6	53.5	51.0	49.7	49.1	50.4	52.3	51.3	47.8	43.7	41.9	40.7	39.4	19.9
95- 115	20	55.7	53.8	46.3	42.7	40.8	40.0	40.1	40.7	39.5	36.8	33.7	32.6	31.6	30.8	15.6
115- 125	10	52.3	49.7	41.3	38.0	35.8	34.8	34.8	34.4	33.5	31.3	28.6	27.6	26.8	26.2	13.4
125- 150	25	41.7	40.1	35.4	32.7	31.2	30.0	29.9	29.2	28.4	26.5	23.9	23.3	22.7	22.1	11.2
150- 175	25	32.2	31.1	28.7	27.3	26.2	25.4	24.7	24.0	23.1	21.4	19.3	18.7	18.3	17.8	9.0
175- 200	25	26.0	25.1	23.8	23.0	22.4	21.2	21.1	20.0	19.1	17.7	15.8	15.4	15.0	14.8	7.5
200- 225	25	22.2	21.2	20.3	19.7	18.9	18.4	17.4	17.1	15.9	14.8	13.3	12.9	12.7	12.6	6.3

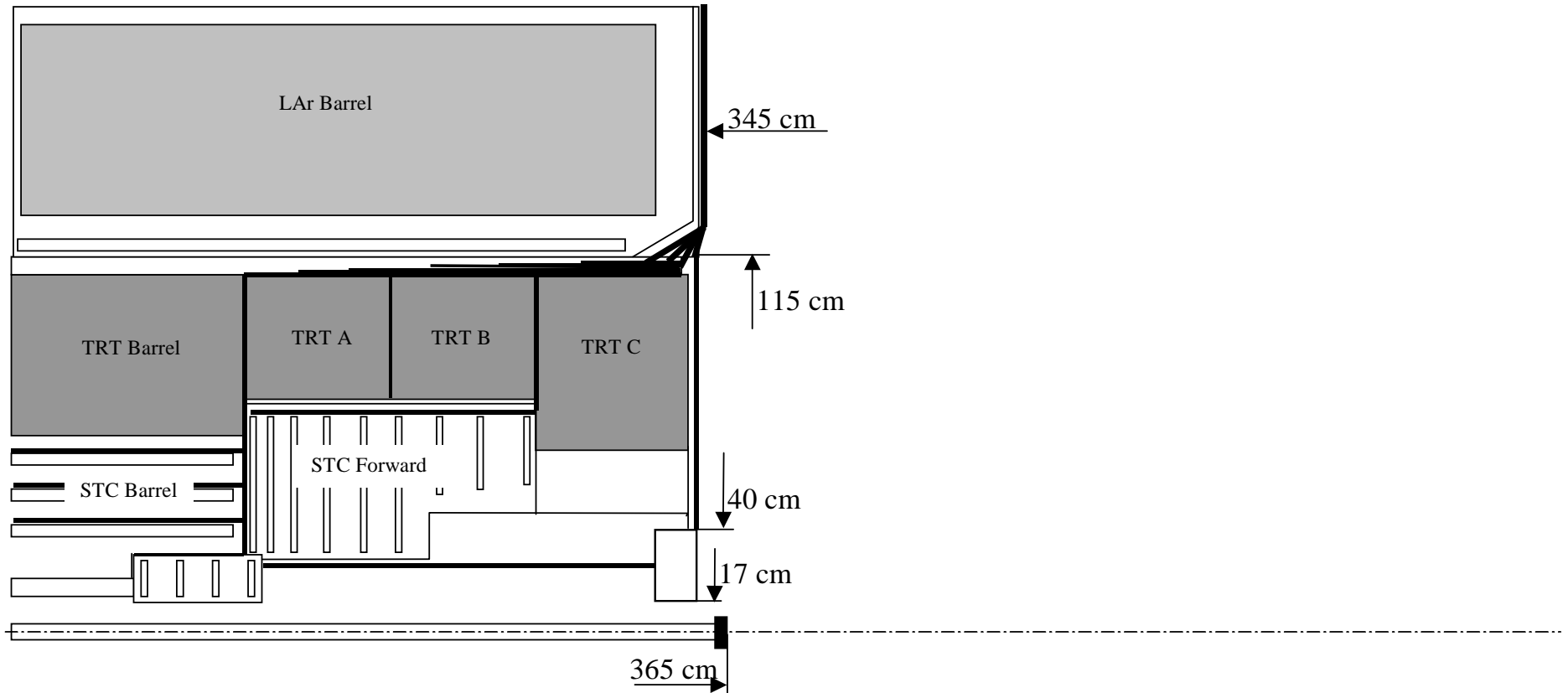

Fig. A1.3. Detector opening layout to calculations of access dose rate – Lar EC and VA removed.

Table A1.3 (continuation)
 Equivalent dose rate in the ID access scenario for T= 100 d, t= 1d – Lar EC and VA removed

R/Z, cm	dR\vdZ	340	340- 350	350- 365	365- 380	380- 405	405- 430	430- 480	480- 530	530- 580	580- 605	605- 630	630- 645	645- 660	660- 670	670
		0	10	15	15	25	25	50	50	50	25	25	15	15	10	0
0- 5	5				175.3	85.3	59.9	44.5	30.2	20.6	15.9	8.8	8.3	7.7	7.1	7.1
5- 10	5	258.5	229.9	203.2	141.0	84.6	59.9	44.5	30.2	20.6	15.8	8.8	8.3	7.7	7.1	7.1
10- 20	10	229.4	200.4	151.3	116.5	83.0	59.9	44.4	29.8	20.8	15.8	8.8	8.3	7.7	7.1	7.1
20- 30	10	189.9	173.0	133.2	105.4	80.2	59.6	43.6	29.4	21.1	15.9	8.8	8.3	7.6	7.1	7.0
30- 45	15	186.7	175.3	125.3	99.2	77.4	59.2	42.0	29.2	21.3	15.7	8.8	8.2	7.6	7.1	7.0
45- 60	15	184.2	176.4	118.7	93.7	74.1	57.8	40.9	28.9	21.4	15.6	8.8	8.2	7.4	6.9	6.9
60- 75	15	153.4	148.5	109.7	88.1	70.8	55.3	39.9	28.2	20.8	15.5	8.7	8.1	7.4	6.8	6.8
75- 95	20	134.5	129.5	100.9	82.7	65.7	52.4	38.5	26.9	20.2	15.2	8.6	7.8	7.2	6.6	6.5
95- 115	20	145.2	132.2	96.6	76.1	60.4	48.0	36.0	25.8	19.5	14.5	8.4	7.6	7.1	6.6	6.4
115- 125	10	140.1	129.3	90.1	70.2	56.1	45.1	34.1	24.7	18.7	14.3	8.3	7.6	7.1	6.5	6.4
125- 150	25	101.3	94.2	74.8	61.9	50.2	41.2	32.3	23.5	17.8	13.8	8.2	7.4	6.6	6.5	6.4
150- 175	25	71.6	67.6	56.3	49.3	42.0	35.2	28.7	21.7	16.9	13.1	7.6	7.1	6.6	6.5	6.4
175- 200	25	51.5	49.1	43.5	39.5	34.6	30.5	25.3	19.8	15.6	12.3	7.4	6.6	6.5	6.3	6.3
200- 225	25	38.8	36.9	33.7	31.4	28.4	25.4	21.7	17.5	14.2	11.5	6.9	6.5	6.4	5.9	5.8

Table A1.3 (continuation)

Equivalent dose rate in the ID access scenario for T= 100 d, t= 5 d – Lar EC and VA removed

R/Z, cm	dR\dZ	340	340- 350	350- 365	365- 380	380- 405	405- 430	430- 480	480- 530	530- 580	580- 605	605- 630	630- 645	645- 660	660- 670	670
		0	10	15	15	25	25	50	50	50	25	25	15	15	10	0
0- 5	5				47.0	25.2	17.0	12.8	8.7	5.7	5.0	2.5	2.2	2.1	2.0	2.0
5- 10	5	99.1	81.5	57.7	39.4	25.0	17.0	12.8	8.7	5.8	5.0	2.5	2.2	2.1	2.0	2.0
10- 20	10	80.3	68.9	45.2	34.1	24.4	16.8	12.8	8.7	6.0	5.0	2.5	2.2	2.1	2.0	2.0
20- 30	10	62.0	56.1	40.5	31.4	23.6	16.9	12.5	8.5	6.1	4.9	2.5	2.2	2.1	2.0	2.0
30- 45	15	60.8	56.8	38.1	29.5	22.5	17.1	12.3	8.5	6.2	4.8	2.5	2.2	2.1	2.0	2.0
45- 60	15	59.4	57.1	35.6	27.5	21.5	16.8	11.6	8.5	6.2	4.7	2.5	2.2	2.1	2.0	2.0
60- 75	15	46.7	45.2	32.5	25.3	20.7	16.1	11.5	8.4	6.0	4.6	2.5	2.1	2.1	2.0	2.0
75- 95	20	39.1	37.6	28.8	23.7	18.9	15.2	11.3	8.0	6.0	4.5	2.4	2.1	2.1	1.8	1.8
95- 115	20	40.3	37.4	27.6	21.7	17.4	14.4	10.6	7.7	5.8	4.1	2.4	2.1	2.0	1.7	1.7
115- 125	10	39.1	36.3	25.6	20.1	16.3	13.1	10.1	7.5	5.7	4.2	2.2	2.1	2.0	1.7	1.7
125- 150	25	29.0	27.1	22.0	18.2	14.9	12.3	9.7	6.9	5.5	4.1	2.1	2.1	1.8	1.6	1.6
150- 175	25	21.7	20.4	17.7	15.3	12.9	10.8	8.8	6.5	5.2	4.0	2.1	2.0	1.7	1.5	1.5
175- 200	25	17.0	15.7	14.5	12.8	11.3	9.4	7.9	6.0	4.6	3.6	2.1	1.8	1.5	1.5	1.5
200- 225	25	13.2	12.3	11.7	10.8	9.2	8.0	6.7	5.5	4.3	3.4	1.8	1.6	1.5	1.5	1.5

Table A1.3 (continuation)

Equivalent dose rate in the ID access scenario for T= 100 d, t= 100d– Lar EC and VA removed

R/Z, cm	dR/dZ	340	340- 350	350- 365	365- 380	380- 405	405- 430	430- 480	480- 530	530- 580	580- 605	605- 630	630- 645	645- 660	660- 670	670
		0	10	15	15	25	25	50	50	50	25	25	15	15	10	0
0- 5	5				22.0	8.8	5.7	4.4	2.8	1.8	1.2	0.7	0.7	0.6	0.6	0.6
5- 10	5	32.3	28.5	25.4	16.6	8.7	5.6	4.3	2.8	1.8	1.2	0.7	0.7	0.6	0.6	0.6
10- 20	10	28.0	24.0	17.2	12.9	8.4	5.6	4.2	2.8	1.8	1.2	0.7	0.7	0.6	0.6	0.6
20- 30	10	21.8	19.7	14.5	11.2	8.1	5.7	4.1	2.8	1.9	1.2	0.7	0.7	0.6	0.6	0.6
30- 45	15	21.7	20.2	13.4	10.2	7.8	5.6	4.1	2.6	2.0	1.2	0.7	0.7	0.6	0.6	0.6
45- 60	15	21.4	20.5	12.5	9.4	7.4	5.5	4.1	2.6	1.9	1.2	0.7	0.7	0.6	0.6	0.6
60- 75	15	16.6	16.3	11.1	8.7	7.0	5.1	4.0	2.5	1.8	1.2	0.7	0.7	0.6	0.6	0.6
75- 95	20	13.5	13.3	9.8	7.9	6.4	5.0	3.9	2.5	1.6	1.2	0.7	0.6	0.6	0.6	0.6
95- 115	20	13.5	12.6	9.4	7.2	5.9	4.7	3.6	2.4	1.6	1.1	0.7	0.6	0.6	0.6	0.6
115- 125	10	13.2	12.2	8.6	6.8	5.2	4.2	3.1	2.4	1.6	1.1	0.7	0.6	0.6	0.6	0.6
125- 150	25	9.9	9.0	7.2	6.0	4.8	4.0	3.1	2.3	1.4	1.1	0.7	0.6	0.6	0.6	0.6
150- 175	25	7.1	6.6	5.5	4.8	4.0	3.5	2.8	2.0	1.3	1.1	0.6	0.6	0.6	0.6	0.6
175- 200	25	5.5	5.2	4.3	4.0	3.6	2.9	2.6	1.7	1.3	1.1	0.6	0.6	0.6	0.6	0.6
200- 225	25	4.5	4.2	3.8	3.3	2.9	2.7	2.3	1.4	1.2	0.9	0.6	0.6	0.6	0.6	0.6

Table A1.3 (continuation)
 Equivalent dose rate in the ID access scenario for T= 10y, t= 1 d- Lar EC and VA removed

R/Z, cm	dR\ dZ	340	340- 350	350- 365	365- 380	380- 405	405- 430	430- 480	480- 530	530- 580	580- 605	605- 630	630- 645	645- 660	660- 670	670
		0	10	15	15	25	25	50	50	50	25	25	15	15	10	0
0- 5	5				242.1	105.3	72.8	53.8	36.3	24.8	19.5	10.9	9.7	8.9	8.5	8.2
5- 10	5	324.1	292.8	276.0	186.3	104.2	72.9	53.8	36.1	24.9	19.5	10.9	9.7	8.8	8.5	8.2
10- 20	10	289.4	251.9	193.3	147.2	101.8	72.6	53.3	36.0	25.2	19.5	10.8	9.7	8.8	8.5	8.2
20- 30	10	236.6	214.4	166.0	130.6	98.3	72.3	52.6	35.6	25.6	19.3	10.8	9.6	8.8	8.4	8.2
30- 45	15	231.3	216.9	154.4	121.3	94.2	71.7	51.1	35.0	25.7	19.2	10.8	9.6	8.7	8.4	8.2
45- 60	15	228.5	218.7	145.1	113.7	89.4	69.9	49.5	34.8	25.6	18.8	10.6	9.5	8.6	8.3	8.2
60- 75	15	188.3	181.8	133.3	106.2	85.0	66.3	48.1	33.8	25.3	18.7	10.6	9.4	8.5	8.3	8.1
75- 95	20	163.3	157.3	122.1	99.2	79.8	62.8	46.6	32.5	24.8	18.3	10.3	9.2	8.5	8.1	8.1
95- 115	20	172.6	157.8	115.6	91.3	72.7	58.4	43.6	31.0	23.4	17.8	10.0	9.0	8.5	8.1	8.1
115- 125	10	167.0	153.5	107.7	84.7	67.6	54.2	41.4	29.6	22.4	17.3	9.8	8.7	8.3	8.1	8.0
125- 150	25	122.6	113.3	89.9	74.4	61.0	49.7	38.8	28.3	21.8	16.8	9.7	8.5	8.1	8.1	8.0
150- 175	25	87.5	82.0	68.9	60.0	51.1	42.8	34.5	26.0	20.6	16.3	9.0	8.4	8.1	7.6	7.6
175- 200	25	64.3	60.5	53.6	48.6	42.9	37.0	30.7	24.0	19.1	14.8	8.6	8.1	7.7	7.2	7.2
200- 225	25	49.1	46.1	42.2	39.2	35.2	31.4	26.3	21.4	17.4	13.8	8.4	7.7	7.2	7.0	7.0

Table A1.3 (continuation)

Equivalent dose rate in the ID access scenario for T= 10y, t= 5 d- Lar EC and VA removed

R/Z, cm	dR\ dZ	340	340- 350	350- 365	365- 380	380- 405	405- 430	430- 480	480- 530	530- 580	580- 605	605- 630	630- 645	645- 660	660- 670	670
		0	10	15	15	25	25	50	50	50	25	25	15	15	10	0
0- 5	5				111.8	45.2	29.8	22.0	14.8	10.0	7.8	4.4	4.1	3.5	3.4	3.4
5- 10	5	164.0	143.6	128.9	83.7	44.7	29.8	22.0	14.8	10.1	7.8	4.4	3.9	3.5	3.4	3.4
10- 20	10	140.7	119.7	86.5	64.1	43.2	29.6	21.9	14.8	10.3	7.9	4.4	3.9	3.5	3.4	3.4
20- 30	10	108.8	97.8	72.4	55.9	41.4	29.5	21.5	14.7	10.5	7.8	4.4	3.9	3.5	3.4	3.4
30- 45	15	105.3	98.2	66.8	51.1	39.0	29.4	20.7	14.6	10.5	7.8	4.3	3.8	3.5	3.3	3.3
45- 60	15	103.2	98.8	62.0	47.1	36.7	29.0	20.2	14.6	10.6	7.7	4.3	3.6	3.5	3.3	3.3
60- 75	15	80.8	78.5	55.8	43.8	34.9	27.2	19.7	14.0	10.6	7.7	4.3	3.6	3.5	3.3	3.3
75- 95	20	67.6	65.2	49.4	40.4	32.3	25.5	19.3	13.6	10.3	7.6	4.3	3.6	3.5	3.2	3.2
95- 115	20	68.1	62.9	46.6	36.8	29.4	23.9	18.1	12.9	9.9	7.4	4.3	3.5	3.5	3.2	3.2
115- 125	10	65.7	61.0	43.7	34.3	27.9	22.3	17.2	12.3	9.5	7.4	4.1	3.5	3.3	3.2	3.2
125- 150	25	50.4	46.4	37.0	30.8	25.2	20.5	16.2	11.5	9.2	7.3	3.7	3.5	3.2	3.2	3.2
150- 175	25	37.9	35.1	29.8	25.6	21.7	18.3	14.8	11.2	8.6	7.1	3.6	3.3	3.2	3.2	3.2
175- 200	25	29.1	27.1	24.8	22.2	19.1	16.2	13.4	10.4	8.0	6.5	3.5	3.2	3.2	3.0	3.0
200- 225	25	23.8	21.9	19.9	18.5	15.9	13.9	11.4	9.4	7.5	5.8	3.3	3.2	3.0	2.4	2.3

Table A1.3 (continuation)

Equivalent dose rate in the ID access scenario for T= 10y, t= 100 d– Lar EC and VA removed

R/Z, cm	dR\dZ	340	340- 350	350- 365	365- 380	380- 405	405- 430	430- 480	480- 530	530- 580	580- 605	605- 630	630- 645	645- 660	660- 670	670
		0	10	15	15	25	25	50	50	50	25	25	15	15	10	0
0- 5	5				82.1	26.5	17.3	12.2	8.4	5.7	4.6	2.0	1.9	1.8	1.8	1.8
5- 10	5	90.2	84.4	91.3	57.6	26.1	17.3	12.2	8.4	5.7	4.6	2.0	1.9	1.8	1.8	1.8
10- 20	10	81.8	69.7	54.9	40.3	25.1	17.2	12.2	8.4	5.7	4.6	2.0	1.9	1.8	1.8	1.8
20- 30	10	63.3	56.5	43.5	33.4	23.7	17.0	12.0	8.4	5.8	4.5	2.0	1.9	1.8	1.8	1.8
30- 45	15	60.6	56.7	39.0	29.8	22.3	16.7	11.8	8.1	5.8	4.4	2.0	1.9	1.8	1.8	1.8
45- 60	15	60.3	57.8	35.8	27.0	20.9	16.2	11.5	8.2	5.9	4.3	2.0	1.8	1.8	1.8	1.8
60- 75	15	47.1	45.8	31.9	24.7	19.9	15.5	11.3	8.0	5.9	4.5	2.0	1.8	1.8	1.6	1.6
75- 95	20	38.6	37.6	28.1	22.7	18.2	14.2	10.8	7.6	5.8	4.2	2.0	1.8	1.8	1.6	1.6
95- 115	20	37.7	35.3	26.2	20.8	16.7	13.3	10.0	7.3	5.5	3.8	1.9	1.8	1.7	1.6	1.6
115- 125	10	36.6	33.6	24.1	19.3	15.4	12.3	9.7	6.8	5.3	3.8	1.9	1.8	1.6	1.6	1.6
125- 150	25	28.1	26.2	20.6	16.9	14.1	11.2	9.1	6.5	5.2	3.7	1.8	1.8	1.6	1.5	1.5
150- 175	25	20.8	19.6	16.5	14.4	12.3	10.4	8.3	6.4	5.0	3.5	1.8	1.6	1.6	1.4	1.4
175- 200	25	16.3	15.3	13.6	12.2	10.9	9.0	7.8	5.8	4.5	3.3	1.7	1.6	1.4	1.4	1.4
200- 225	25	13.8	12.7	11.5	10.5	9.2	8.1	6.4	5.4	3.9	2.9	1.6	1.4	1.4	1.4	1.4

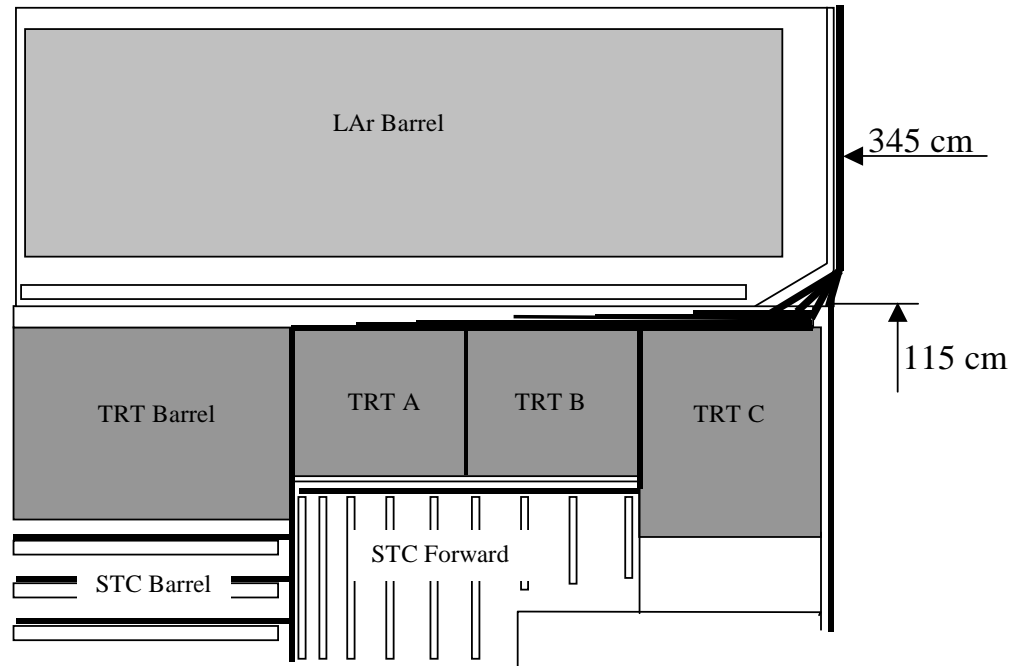

Fig. A1.4. Detector opening layout to calculations of access dose rate – Lar EC, VA, Pixel, and VI removed.

Table A1.4 (continuation)
 Equivalent dose rate in the ID access scenario for T= 100 d, t= 1 d– Lar EC, VA, Pixel, and VI removed

R/Z, cm	dR\vdZ	340	340- 350	350- 365	365- 380	380- 405	405- 430	430- 480	480- 530	530- 580	580- 605	605- 630	630- 645	645- 660	660- 670	670
		0	10	15	15	25	25	50	50	50	25	25	15	15	10	0
0- 5	5	95.3	92.0	84.2	76.0	63.7	49.3	38.9	27.0	18.5	14.4	7.4	7.0	6.6	6.0	6.0
5- 10	5	95.7	92.3	84.4	75.9	63.6	49.4	38.9	27.0	18.5	14.3	7.4	7.0	6.6	6.0	6.0
10- 20	10	97.5	93.7	85.4	75.9	63.7	49.7	38.8	26.6	18.7	14.3	7.4	7.0	6.6	6.0	6.0
20- 30	10	101.7	98.1	87.4	75.7	63.1	49.9	38.1	26.3	19.1	14.4	7.4	7.0	6.5	6.0	6.0
30- 45	15	130.4	125.8	92.4	76.5	62.8	50.2	36.8	26.1	19.3	14.2	7.4	6.9	6.5	6.0	6.0
45- 60	15	152.4	147.1	95.9	76.5	62.1	49.7	36.0	26.0	19.4	14.1	7.4	6.9	6.3	5.8	5.8
60- 75	15	133.2	129.3	93.4	74.9	60.8	48.2	35.3	25.3	18.8	14.0	7.3	6.8	6.3	5.7	5.7
75- 95	20	121.3	116.7	89.4	72.8	57.8	46.3	34.4	24.2	18.4	13.7	7.3	6.7	6.1	5.6	5.6
95- 115	20	136.2	123.3	88.3	68.6	54.1	43.0	32.4	23.3	17.7	13.1	7.1	6.5	6.0	5.6	5.6
115- 125	10	133.0	122.3	83.5	64.2	50.8	40.6	30.8	22.3	17.0	12.9	7.0	6.5	6.0	5.5	5.5
125- 150	25	95.6	88.5	69.4	56.9	45.8	37.3	29.3	21.2	16.2	12.4	7.0	6.3	5.6	5.5	5.5
150- 175	25	67.2	63.2	52.2	45.3	38.5	32.1	26.1	19.8	15.4	11.8	6.5	6.0	5.6	5.5	5.5
175- 200	25	48.1	45.7	40.2	36.3	31.7	27.8	23.0	18.0	14.2	11.1	6.3	5.6	5.5	5.3	5.3
200- 225	25	35.9	34.0	30.9	28.7	25.9	23.1	19.8	15.9	12.9	10.4	5.9	5.5	5.4	5.0	5.0

Table A1.4 (continuation)

Equivalent dose rate in the ID access scenario for T= 100 d, t= 5 d– Lar EC, VA, Pixel, and VI removed

R/Z, cm	dR\dZ	340	340- 350	350- 365	365- 380	380- 405	405- 430	430- 480	480- 530	530- 580	580- 605	605- 630	630- 645	645- 660	660- 670	670
		0	10	15	15	25	25	50	50	50	25	25	15	15	10	0
0- 5	5	26.4	25	21.9	20.1	17.5	12.8	10.4	7.2	4.7	4.2	2	1.8	1.7	1.6	1.6
5- 10	5	26.5	25.1	22.1	20.3	17.5	12.8	10.4	7.2	4.7	4.2	2	1.8	1.7	1.6	1.6
10- 20	10	27	25.8	22.4	20.4	17.4	12.7	10.4	7.2	5	4.2	2	1.8	1.7	1.6	1.6
20- 30	10	28.4	27.3	23.7	20.7	17.2	13.1	10.1	7	5.1	4.2	2	1.8	1.7	1.6	1.6
30- 45	15	40	38.4	26	21	16.9	13.5	9.9	7.1	5.3	4.1	2	1.8	1.7	1.6	1.6
45- 60	15	47.7	46.2	26.9	20.8	16.7	13.7	9.4	7.2	5.3	3.9	2	1.8	1.7	1.6	1.6
60- 75	15	38.9	37.8	26	20.2	16.8	13.2	9.6	7.1	5.1	3.9	2	1.7	1.7	1.6	1.6
75- 95	20	33.8	32.5	24.3	19.8	15.6	12.7	9.6	6.9	5.2	3.9	1.9	1.7	1.7	1.4	1.4
95- 115	20	36.6	33.8	24.2	18.7	14.8	12.3	9	6.5	5	3.5	1.9	1.7	1.6	1.3	1.3
115- 125	10	36.3	33.4	22.9	17.6	14	11.3	8.6	6.4	5	3.6	1.8	1.7	1.6	1.3	1.3
125- 150	25	26.8	24.9	19.9	16.1	13	10.7	8.3	5.9	4.7	3.6	1.7	1.7	1.4	1.3	1.3
150- 175	25	20.1	18.8	16	13.7	11.5	9.4	7.7	5.7	4.6	3.4	1.7	1.6	1.3	1.2	1.2
175- 200	25	15.7	14.4	13.1	11.6	10	8.3	7.1	5.3	4	3.1	1.7	1.4	1.2	1.2	1.2
200- 225	25	12.1	11.2	10.5	9.7	8.2	7.1	6	4.8	3.7	2.9	1.4	1.3	1.2	1.2	1.2

Table A1.4 (continuation)
 Equivalent dose rate in the ID access scenario for T= 100 d, t=100d– Lar EC, VA, Pixel, and VI removed

R/Z, cm	dR/dZ	340	340- 350	350- 365	365- 380	380- 405	405- 430	430- 480	480- 530	530- 580	580- 605	605- 630	630- 645	645- 660	660- 670	670
		0	10	15	15	25	25	50	50	50	25	25	15	15	10	0
0- 5	5	8.5	8.1	7.3	6.8	5.6	4.1	3.4	2.2	1.4	0.9	0.5	0.5	0.5	0.5	0.5
5- 10	5	8.5	8.1	7.3	6.8	5.6	4.1	3.3	2.2	1.4	0.9	0.5	0.5	0.5	0.5	0.5
10- 20	10	8.7	8.3	7.5	6.8	5.6	4.1	3.3	2.2	1.4	0.9	0.5	0.5	0.5	0.5	0.5
20- 30	10	9.3	8.9	8	6.9	5.6	4.2	3.3	2.2	1.6	0.9	0.5	0.5	0.5	0.5	0.5
30- 45	15	14	13.4	8.7	7	5.6	4.3	3.2	2.2	1.6	0.9	0.5	0.5	0.5	0.5	0.5
45- 60	15	17.1	16.5	9.3	7	5.6	4.3	3.2	2.2	1.6	0.9	0.5	0.5	0.5	0.5	0.5
60- 75	15	13.8	13.5	8.8	6.8	5.5	4.1	3.3	2.1	1.5	0.9	0.5	0.5	0.5	0.5	0.5
75- 95	20	11.7	11.5	8.2	6.4	5.2	4.1	3.3	2.1	1.4	0.9	0.5	0.5	0.5	0.5	0.5
95- 115	20	12.2	11.2	8.1	6	4.9	3.9	2.9	2.1	1.4	0.9	0.5	0.5	0.5	0.5	0.5
115- 125	10	12.1	11.1	7.6	5.8	4.3	3.5	2.7	2.1	1.3	0.9	0.5	0.5	0.5	0.5	0.5
125- 150	25	9.1	8.1	6.4	5.3	4	3.4	2.6	1.9	1.1	0.9	0.5	0.5	0.5	0.5	0.5
150- 175	25	6.6	6.1	5	4.3	3.5	3.1	2.5	1.7	1.1	0.9	0.5	0.5	0.5	0.5	0.5
175- 200	25	5.1	4.8	3.9	3.6	3.2	2.6	2.3	1.5	1.1	0.9	0.5	0.5	0.5	0.5	0.5
200- 225	25	4.1	3.7	3.4	3	2.6	2.4	2	1.2	1	0.8	0.5	0.5	0.5	0.5	0.5

Table A1.4 (continuation)
 Equivalent dose rate in the ID access scenario for T= 10y, t= 1d – Lar EC, VA, Pixel, and VI removed

R/Z, cm	dR\vdZ	340	340- 350	350- 365	365- 380	380- 405	405- 430	430- 480	480- 530	530- 580	580- 605	605- 630	630- 645	645- 660	660- 670	670
		0	10	15	15	25	25	50	50	50	25	25	15	15	10	0
0- 5	5	111.9	108.1	99.5	90.0	75.4	58.6	46.4	32.1	22.0	17.4	9.0	8.1	7.5	7.1	7.0
5- 10	5	112.7	108.7	99.8	89.9	75.3	58.8	46.4	31.9	22.1	17.4	9.0	8.1	7.4	7.1	7.0
10- 20	10	114.5	110.8	101.4	89.7	75.2	58.9	45.9	31.8	22.4	17.4	9.0	8.1	7.4	7.1	7.0
20- 30	10	120.2	116.2	104.3	90.2	75.1	59.3	45.3	31.5	22.8	17.3	9.0	8.0	7.4	7.0	7.0
30- 45	15	157.8	152.5	110.9	91.1	74.6	59.8	44.1	30.9	23.0	17.2	9.0	8.0	7.3	7.0	7.0
45- 60	15	187.0	180.4	115.3	91.1	73.5	59.3	42.9	30.9	23.0	16.8	8.8	7.9	7.2	7.0	7.0
60- 75	15	162.1	156.9	112.1	89.0	72.0	57.1	42.1	30.1	22.8	16.7	8.8	7.8	7.1	7.0	7.0
75- 95	20	146.2	140.7	107.2	86.3	69.3	54.9	41.2	28.9	22.4	16.3	8.6	7.6	7.1	6.8	6.8
95- 115	20	160.8	146.3	104.9	81.6	64.5	51.8	38.8	27.7	21.1	15.9	8.4	7.6	7.1	6.8	6.8
115- 125	10	157.8	144.4	99.1	76.7	60.6	48.4	37.0	26.5	20.1	15.4	8.2	7.3	7.0	6.8	6.8
125- 150	25	115.2	106.1	82.9	67.9	55.2	44.6	34.8	25.4	19.6	15.1	8.1	7.1	6.8	6.8	6.8
150- 175	25	81.9	76.4	63.6	54.9	46.4	38.6	31.1	23.5	18.6	14.6	7.6	7.1	6.8	6.4	6.3
175- 200	25	59.8	56.0	49.3	44.5	39.0	33.5	27.8	21.7	17.2	13.2	7.2	6.8	6.5	6.0	6.0
200- 225	25	45.5	42.5	38.7	35.8	32.0	28.4	23.8	19.3	15.7	12.4	7.1	6.5	6.0	5.8	5.8

Table A1.4 (continuation)
 Equivalent dose rate in the ID access scenario for T= 10y, t= 5 d– Lar EC, VA, Pixel, and VI removed

R/Z, cm	dR\dZ	340	340- 350	350- 365	365- 380	380- 405	405- 430	430- 480	480- 530	530- 580	580- 605	605- 630	630- 645	645- 660	660- 670	670
		0	10	15	15	25	25	50	50	50	25	25	15	15	10	0
0- 5	5	43.7	41	37	33.8	29	21.7	17.5	12.1	8.2	6.4	3.5	3.2	2.7	2.6	2.5
5- 10	5	43.7	41.3	37.2	33.8	29	21.7	17.5	12.1	8.2	6.4	3.5	3	2.7	2.6	2.5
10- 20	10	44.7	42.4	38	34	28.8	21.7	17.4	12.1	8.4	6.4	3.5	3	2.7	2.6	2.5
20- 30	10	47.2	45.4	39.6	34.3	28.8	22.1	17.1	12.1	8.7	6.4	3.5	3	2.7	2.6	2.5
30- 45	15	67	64.6	43.6	35	28.2	22.5	16.7	12.1	8.8	6.3	3.4	2.9	2.7	2.5	2.4
45- 60	15	81.8	78.7	46	35	27.8	22.8	16.3	12.2	8.9	6.4	3.4	2.8	2.7	2.5	2.4
60- 75	15	67.2	65	44.3	34.2	27.6	22	16.2	11.7	9	6.5	3.4	2.8	2.7	2.5	2.4
75- 95	20	58	56	41.2	33.1	26.4	21.1	16.1	11.4	8.8	6.3	3.4	2.8	2.7	2.5	2.4
95- 115	20	61.1	56.4	40.3	31.3	24.8	20.1	15.1	11	8.3	6.3	3.4	2.7	2.7	2.5	2.4
115- 125	10	60.3	55.6	38.6	29.5	23.8	18.8	14.6	10.4	8	6.2	3.2	2.7	2.5	2.5	2.4
125- 150	25	46.2	42.5	33.2	27.1	21.9	17.7	13.9	9.8	7.8	6.2	2.9	2.7	2.5	2.5	2.4
150- 175	25	35	32.2	27.1	23	19.2	16.1	12.7	9.8	7.4	6.1	2.8	2.6	2.5	2.5	2.4
175- 200	25	26.8	24.8	22.4	19.9	17	14.3	11.8	9	6.8	5.6	2.7	2.5	2.5	2.4	2.4
200- 225	25	21.9	20	18.1	16.8	14.3	12.3	10	8.1	6.5	4.9	2.6	2.5	2.4	1.9	1.9

Table A1.4 (continuation)
 Equivalent dose rate in the ID access scenario for T= 10y, t= 100 d– Lar EC, VA, Pixel, and VI removed

R/Z, cm	dR\dZ	340	340- 350	350- 365	365- 380	380- 405	405- 430	430- 480	480- 530	530- 580	580- 605	605- 630	630- 645	645- 660	660- 670	670
		0	10	15	15	25	25	50	50	50	25	25	15	15	10	0
0- 5	5	23.2	22.6	20.9	18.7	15.6	12.3	9.4	6.7	4.5	3.6	1.4	1.4	1.3	1.3	1.3
5- 10	5	23.6	22.6	21	18.9	15.6	12.3	9.4	6.7	4.6	3.6	1.4	1.4	1.3	1.3	1.3
10- 20	10	24.1	23.4	21.5	18.9	15.5	12.3	9.4	6.7	4.6	3.6	1.4	1.4	1.3	1.3	1.3
20- 30	10	25.6	25	22.5	19.1	15.5	12.4	9.3	6.7	4.7	3.6	1.4	1.4	1.3	1.3	1.3
30- 45	15	37.4	36.5	24.6	19.3	15.5	12.5	9.2	6.7	4.8	3.6	1.4	1.4	1.3	1.3	1.3
45- 60	15	46.9	45.5	25.8	19.4	15.4	12.5	9.1	6.6	4.8	3.6	1.4	1.3	1.3	1.3	1.3
60- 75	15	38.5	37.7	24.9	19	15.3	12.2	9.2	6.6	4.9	3.6	1.4	1.3	1.3	1.2	1.2
75- 95	20	33	32.2	23.1	18.4	14.7	11.6	8.8	6.3	4.8	3.5	1.4	1.3	1.3	1.2	1.2
95- 115	20	33.8	31.4	22.6	17.4	13.8	11	8.2	6.2	4.7	3.1	1.4	1.3	1.3	1.2	1.2
115- 125	10	33.5	30.5	21.2	16.6	13	10.2	8.1	5.7	4.5	3.1	1.4	1.3	1.2	1.2	1.2
125- 150	25	25.8	23.9	18.4	14.8	12	9.5	7.7	5.4	4.4	3	1.3	1.3	1.2	1.2	1.2
150- 175	25	19.1	17.9	14.8	12.8	10.8	9	7.2	5.4	4.4	2.9	1.3	1.2	1.2	1.1	1.1
175- 200	25	15	14	12.3	10.9	9.5	7.9	6.7	5	3.8	2.7	1.3	1.2	1.1	1.1	1.1
200- 225	25	12.7	11.6	10.4	9.4	8.1	7.1	5.6	4.6	3.3	2.5	1.2	1.1	1.1	1.1	1.1

Addendum 2

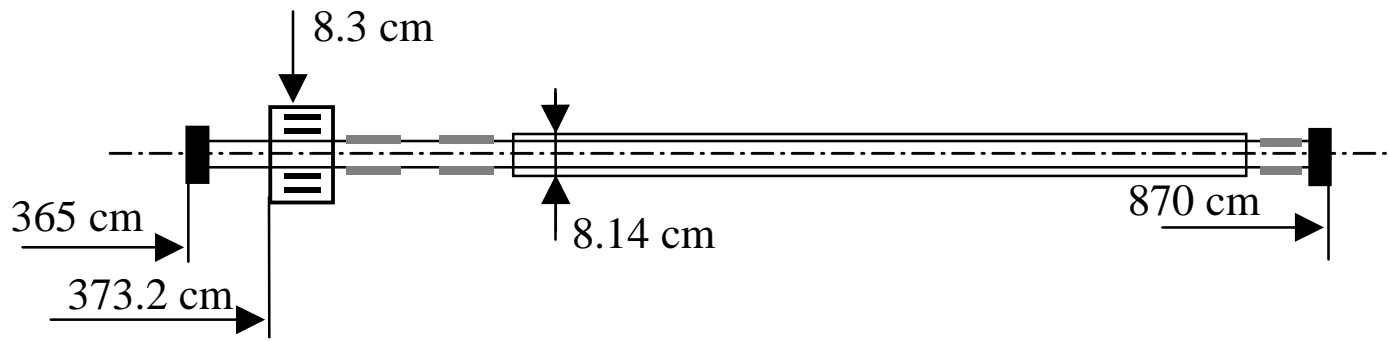

Fig. A2.1 Sketch of the VA Beam pipe section.

Table A2.1

Equivalent dose rate induced by high-energy hadrons from steel LAr Beam Pipe for T= 100d, t=5d

R/Z, cm	350	365	370	385	415	450	500	600	700	750	800	850	870	880
0	357.8	3406.9											2540.6	414.8
5	342.6	3305.9	2502.6	2566.8	2100.6	2669.3	4926.9	3712.1	2852.9	2533.3	2513.5	1764.9	2432.2	380.1
7	329.6	1589.9	1808.1	1804.0	1406.1	1753.6	3111.5	2395.1	1848.8	1645.4	1615.9	1230.7	1144.1	352.8
10	306.1	939.4	1185.2	1223.6	960.4	1196.1	2024.4	1600.2	1240.4	1105.1	1070.6	842.0	657.9	309.2
15	264.6	564.3	677.4	749.7	641.2	793.4	1258.5	1033.1	805.8	718.3	682.8	538.9	392.5	246.4
20	227.2	396.9	454.4	517.8	485.3	595.3	895.8	759.4	595.9	531.2	496.8	388.0	281.7	201.3
25	196.5	302.8	336.8	387.6	390.5	475.6	685.3	597.2	471.3	420.1	387.5	299.1	220.5	169.3
50	111.8	136.1	143.8	163.4	190.9	228.4	288.7	275.6	223.5	199.0	175.1	132.6	107.2	93.9
75	77.3	88.1	91.7	102.1	120.7	142.1	169.3	169.1	140.7	125.2	108.0	83.3	71.1	64.9
100	58.8	65.1	67.2	73.5	85.6	98.8	114.1	116.7	99.4	88.6	76.1	60.1	53.0	49.4
125	47.2	51.3	52.6	56.8	64.8	73.5	83.2	86.1	74.8	66.9	57.7	46.7	42.0	39.7
150	39.2	42.0	42.9	45.7	51.3	57.2	63.7	66.4	58.6	52.7	45.8	37.9	34.6	33.0
175	33.2	35.2	35.9	37.9	41.9	46.0	50.7	52.8	47.3	42.9	37.6	31.6	29.2	28.0
200	28.7	30.1	30.6	32.1	35.0	38.0	41.4	43.1	39.1	35.6	31.5	27.0	25.1	24.2
225	25.0	26.1	26.5	27.6	29.8	32.0	34.5	35.9	32.8	30.1	26.9	23.4	21.9	21.2

Table A2.1 (continuation)

Equivalent dose rate induced by high-energy hadrons from steel LAr Beam Pipe for T= 10y, t=5d

R/Z, cm	350	365	370	385	415	450	500	600	700	750	800	850	870	880
0	402.0	3824.9											2858.0	466.6
5	384.9	3711.8	2810.0	2879.9	2364.8	3008.9	5571.7	4182.9	3209.7	2850.7	2827.7	1984.6	2735.9	427.6
7	370.3	1785.3	2030.4	2024.6	1582.7	1976.9	3518.2	2698.8	2080.0	1851.5	1817.9	1384.0	1287.0	396.9
10	344.0	1055.0	1331.1	1373.6	1080.8	1348.6	2288.8	1803.1	1395.5	1243.5	1204.5	946.9	740.0	347.8
15	297.3	633.9	760.9	841.9	721.6	894.6	1422.5	1164.1	906.6	808.4	768.1	606.1	441.5	277.2
20	255.4	445.9	510.5	581.7	546.2	671.3	1012.3	855.8	670.4	597.8	559.0	436.4	316.8	226.4
25	220.8	340.3	378.5	435.6	439.6	536.4	774.3	673.0	530.3	472.8	436.0	336.5	248.0	190.4
50	125.8	153.1	161.8	183.9	215.0	257.6	326.0	310.6	251.5	223.9	197.1	149.2	120.6	105.7
75	87.0	99.2	103.3	114.9	136.0	160.2	191.1	190.6	158.4	140.9	121.6	93.7	80.0	73.1
100	66.2	73.3	75.7	82.8	96.4	111.4	128.7	131.5	111.9	99.7	85.6	67.7	59.6	55.6
125	53.2	57.8	59.3	64.0	73.0	82.9	93.8	97.0	84.2	75.3	64.9	52.5	47.3	44.7
150	44.1	47.3	48.3	51.5	57.8	64.5	71.9	74.8	66.0	59.4	51.6	42.6	38.9	37.1
175	37.4	39.7	40.4	42.7	47.2	51.9	57.1	59.5	53.3	48.3	42.3	35.6	32.9	31.5
200	32.3	33.9	34.5	36.2	39.4	42.8	46.6	48.6	44.0	40.1	35.5	30.4	28.3	27.3
225	28.2	29.5	29.9	31.1	33.5	36.1	38.9	40.4	37.0	33.9	30.3	26.3	24.7	23.9

Table A2.1 (continuation)

Equivalent dose rate induced by high-energy hadrons from steel LAr Beam Pipe for T= 100d, t=100d

R/Z, cm	350	365	370	385	415	450	500	600	700	750	800	850	870	880
0	60.8	568.8											440.7	72.1
5	58.2	552.1	421.6	436.7	359.9	466.2	901.6	666.9	504.4	443.1	438.4	306.8	421.6	66.1
7	56.0	267.0	305.5	307.2	241.3	306.9	568.8	430.2	326.8	287.9	281.9	214.0	198.5	61.3
10	52.1	158.6	200.9	208.6	165.1	209.9	369.6	287.4	219.3	193.5	186.8	146.5	114.2	53.8
15	45.2	95.9	115.2	128.1	110.6	139.6	229.4	185.5	142.4	125.9	119.2	93.8	68.3	42.9
20	38.9	67.7	77.5	88.7	84.0	105.0	163.0	136.4	105.3	93.2	86.8	67.6	49.0	35.1
25	33.7	51.8	57.7	66.5	67.7	84.1	124.5	107.3	83.3	73.7	67.7	52.2	38.4	29.5
50	19.4	23.6	24.9	28.4	33.4	40.6	52.1	49.5	39.6	35.0	30.7	23.2	18.8	16.4
75	13.5	15.4	16.0	17.9	21.3	25.3	30.4	30.3	24.9	22.1	19.0	14.6	12.5	11.4
100	10.3	11.4	11.8	12.9	15.1	17.6	20.5	20.9	17.6	15.7	13.4	10.6	9.3	8.7
125	8.3	9.1	9.3	10.0	11.5	13.1	14.9	15.4	13.3	11.8	10.2	8.2	7.4	7.0
150	6.9	7.4	7.6	8.1	9.1	10.2	11.4	11.9	10.4	9.3	8.1	6.7	6.1	5.8
175	5.9	6.2	6.4	6.7	7.4	8.2	9.0	9.4	8.4	7.6	6.6	5.6	5.2	5.0
200	5.1	5.3	5.4	5.7	6.2	6.8	7.4	7.7	6.9	6.3	5.6	4.8	4.4	4.3
225	4.4	4.6	4.7	4.9	5.3	5.7	6.2	6.4	5.8	5.3	4.8	4.1	3.9	3.8

Table A2.1 (continuation)

Equivalent dose rate induced by high-energy hadrons from steel LAr Beam Pipe for T= 10y, t=100d

R/Z, cm	350	365	370	385	415	450	500	600	700	750	800	850	870	880
0	91.8	862.4											664.8	108.6
5	87.9	837.2	637.5	657.2	543.3	705.1	1350.6	995.2	755.4	666.1	660.2	462.0	636.0	99.6
7	84.6	404.2	461.6	462.5	364.1	463.8	852.0	641.9	489.4	432.8	424.4	322.2	299.3	92.4
10	78.7	239.9	303.4	314.2	249.1	316.9	553.8	428.8	328.3	290.8	281.3	220.5	172.2	81.0
15	68.1	144.7	173.9	193.0	166.8	210.6	343.7	276.9	213.3	189.2	179.4	141.2	102.8	64.6
20	58.7	102.1	117.0	133.6	126.5	158.3	244.2	203.6	157.7	140.0	130.6	101.7	73.8	52.8
25	50.8	78.2	86.9	100.2	102.1	126.6	186.6	160.1	124.8	110.8	101.9	78.5	57.8	44.4
50	29.2	35.5	37.5	42.8	50.3	61.0	78.1	73.9	59.2	52.6	46.1	34.9	28.2	24.7
75	20.3	23.2	24.1	26.9	32.0	38.0	45.6	45.3	37.3	33.1	28.5	22.0	18.7	17.1
100	15.5	17.2	17.8	19.5	22.7	26.4	30.7	31.3	26.4	23.5	20.1	15.9	14.0	13.1
125	12.5	13.6	14.0	15.1	17.3	19.6	22.3	23.0	19.9	17.7	15.3	12.3	11.1	10.5
150	10.4	11.1	11.4	12.2	13.7	15.3	17.1	17.8	15.6	14.0	12.1	10.0	9.2	8.7
175	8.8	9.4	9.5	10.1	11.2	12.3	13.6	14.1	12.6	11.4	10.0	8.4	7.7	7.4
200	7.6	8.0	8.2	8.5	9.3	10.1	11.1	11.5	10.4	9.5	8.4	7.2	6.7	6.4
225	6.7	7.0	7.1	7.4	7.9	8.5	9.2	9.6	8.7	8.0	7.2	6.2	5.8	5.6

Table A2.2

Equivalent dose rate induced by low-energy neutrons from steel LAr Beam Pipe for T= 100d, t=5d

R/Z, cm	350	365	370	385	415	450	500	600	700	750	800	850	870	880
0	10.1	75.8											50.1	8.3
5	9.8	76.8	66.0	62.0	39.2	83.4	322.4	148.9	61.3	55.1	51.5	30.4	52.6	7.7
7	9.4	40.1	52.2	46.1	28.5	57.5	200.0	94.8	40.0	35.6	33.0	21.7	23.1	7.1
10	8.9	25.8	36.1	33.0	21.5	41.6	128.0	63.0	27.3	24.1	22.0	15.3	12.9	6.2
15	7.9	16.5	20.6	21.0	16.2	29.7	77.6	40.7	18.3	15.9	14.2	10.2	7.7	5.0
20	6.9	11.9	13.8	14.8	13.4	23.4	53.8	30.0	13.9	11.9	10.5	7.6	5.6	4.1
25	6.1	9.2	10.3	11.4	11.6	19.3	40.2	23.7	11.3	9.6	8.3	6.0	4.5	3.5
50	3.8	4.5	4.8	5.5	6.9	9.9	15.2	11.1	6.0	4.9	4.0	2.9	2.4	2.1
75	2.8	3.2	3.3	3.7	4.7	6.2	8.3	6.8	4.1	3.3	2.7	2.0	1.7	1.6
100	2.2	2.5	2.6	2.8	3.5	4.3	5.3	4.7	3.0	2.5	2.0	1.5	1.4	1.3
125	1.8	2.0	2.1	2.2	2.7	3.1	3.7	3.4	2.4	2.0	1.6	1.3	1.1	1.1
150	1.5	1.7	1.7	1.8	2.1	2.4	2.7	2.6	1.9	1.6	1.3	1.1	1.0	0.9
175	1.3	1.4	1.4	1.5	1.7	1.9	2.1	2.0	1.6	1.3	1.1	0.9	0.9	0.8
200	1.1	1.2	1.2	1.3	1.4	1.6	1.7	1.7	1.3	1.1	1.0	0.8	0.8	0.7
225	1.0	1.0	1.1	1.1	1.2	1.3	1.4	1.4	1.1	1.0	0.9	0.7	0.7	0.7

Table A2.2 (continuation)

Equivalent dose rate induced by low-energy neutrons from steel LAr Beam Pipe for T= 10y, t=5d

R/Z, cm	350	365	370	385	415	450	500	600	700	750	800	850	870	880
0	20.5	147.1											67.0	11.2
5	19.8	149.7	144.8	133.4	89.4	143.6	425.4	187.9	81.7	73.4	68.5	40.7	70.5	10.2
7	19.1	82.4	117.8	101.9	62.2	96.6	263.9	120.0	53.2	47.5	43.9	29.1	31.0	9.5
10	18.0	55.1	82.3	73.8	44.6	68.2	168.9	80.0	36.3	32.1	29.3	20.5	17.3	8.3
15	15.8	35.4	45.8	46.1	31.8	47.2	102.5	51.8	24.3	21.1	19.0	13.6	10.3	6.7
20	13.7	25.0	29.5	31.5	25.3	36.4	71.3	38.3	18.5	15.9	14.0	10.1	7.5	5.5
25	11.9	18.9	21.3	23.3	21.1	29.6	53.4	30.4	15.0	12.7	11.1	8.0	6.0	4.7
50	6.8	8.2	8.7	9.8	11.4	14.7	20.5	14.4	7.9	6.5	5.4	3.9	3.2	2.9
75	4.6	5.3	5.5	6.2	7.4	9.1	11.3	8.9	5.4	4.4	3.6	2.7	2.3	2.1
100	3.5	3.9	4.0	4.4	5.2	6.2	7.3	6.2	4.0	3.3	2.7	2.1	1.8	1.7
125	2.8	3.1	3.2	3.4	3.9	4.5	5.1	4.5	3.2	2.6	2.1	1.7	1.5	1.4
150	2.3	2.5	2.6	2.7	3.1	3.5	3.8	3.5	2.6	2.2	1.8	1.4	1.3	1.3
175	2.0	2.1	2.1	2.2	2.5	2.7	3.0	2.8	2.1	1.8	1.5	1.3	1.2	1.1
200	1.7	1.8	1.8	1.9	2.0	2.2	2.4	2.3	1.8	1.5	1.3	1.1	1.0	1.0
225	1.4	1.5	1.5	1.6	1.7	1.8	1.9	1.9	1.5	1.3	1.2	1.0	0.9	0.9

Table A2.2 (continuation)

Equivalent dose rate induced by low-energy neutrons from steel LAr Beam Pipe for T= 100d, t=100d

R/Z, cm	350	365	370	385	415	450	500	600	700	750	800	850	870	880
0	4.8	35.8											22.0	3.7
5	4.7	36.3	32.1	30.0	19.3	38.4	140.3	64.3	26.8	24.1	22.6	13.3	23.1	3.4
7	4.5	19.2	25.6	22.5	13.8	26.3	87.0	41.0	17.5	15.6	14.4	9.5	10.1	3.1
10	4.2	12.5	17.7	16.1	10.3	18.9	55.7	27.3	11.9	10.5	9.6	6.7	5.7	2.7
15	3.7	8.0	10.1	10.2	7.7	13.4	33.8	17.6	8.0	7.0	6.2	4.5	3.4	2.2
20	3.3	5.7	6.7	7.2	6.3	10.5	23.4	13.0	6.1	5.2	4.6	3.3	2.5	1.8
25	2.9	4.4	4.9	5.4	5.4	8.7	17.5	10.3	4.9	4.2	3.6	2.6	2.0	1.5
50	1.7	2.1	2.2	2.5	3.1	4.4	6.7	4.8	2.6	2.1	1.8	1.3	1.1	0.9
75	1.3	1.5	1.5	1.7	2.1	2.8	3.6	3.0	1.8	1.4	1.2	0.9	0.8	0.7
100	1.0	1.1	1.2	1.3	1.5	1.9	2.3	2.0	1.3	1.1	0.9	0.7	0.6	0.6
125	0.8	0.9	0.9	1.0	1.2	1.4	1.6	1.5	1.0	0.9	0.7	0.6	0.5	0.5
150	0.7	0.7	0.8	0.8	0.9	1.1	1.2	1.1	0.8	0.7	0.6	0.5	0.4	0.4
175	0.6	0.6	0.6	0.7	0.8	0.8	0.9	0.9	0.7	0.6	0.5	0.4	0.4	0.4
200	0.5	0.5	0.5	0.6	0.6	0.7	0.8	0.7	0.6	0.5	0.4	0.4	0.3	0.3
225	0.4	0.5	0.5	0.5	0.5	0.6	0.6	0.6	0.5	0.4	0.4	0.3	0.3	0.3

Table A2.2 (continuation)
 Equivalent dose rate induced by low-energy neutrons from steel LAr Beam Pipe for T= 10y, t=100d

R/Z, cm	350	365	370	385	415	450	500	600	700	750	800	850	870	880
0	14.1	99.2											33.9	5.7
5	13.6	101.2	103.8	94.8	65.2	90.1	212.3	89.2	41.3	37.1	34.6	20.6	35.8	5.2
7	13.2	57.3	85.5	73.3	44.5	59.6	131.7	57.1	26.9	24.0	22.2	14.8	15.7	4.8
10	12.4	39.0	60.0	53.3	31.2	41.3	84.3	38.2	18.3	16.2	14.8	10.4	8.8	4.2
15	10.8	25.1	33.0	33.0	21.6	27.9	51.3	24.8	12.3	10.7	9.6	6.9	5.2	3.4
20	9.4	17.6	21.0	22.2	16.8	21.2	35.8	18.4	9.3	8.0	7.1	5.1	3.8	2.8
25	8.1	13.1	14.9	16.2	13.7	17.1	26.8	14.7	7.6	6.4	5.6	4.1	3.0	2.4
50	4.4	5.3	5.6	6.3	6.9	8.2	10.5	7.1	4.0	3.3	2.7	2.0	1.6	1.5
75	2.9	3.3	3.4	3.7	4.3	5.0	5.8	4.4	2.7	2.2	1.8	1.4	1.2	1.1
100	2.1	2.3	2.4	2.6	3.0	3.4	3.8	3.1	2.0	1.7	1.4	1.1	0.9	0.9
125	1.6	1.8	1.8	2.0	2.2	2.5	2.7	2.3	1.6	1.3	1.1	0.9	0.8	0.7
150	1.3	1.4	1.4	1.5	1.7	1.9	2.0	1.8	1.3	1.1	0.9	0.7	0.7	0.6
175	1.1	1.2	1.2	1.2	1.4	1.5	1.6	1.4	1.1	0.9	0.8	0.6	0.6	0.6
200	0.9	1.0	1.0	1.0	1.1	1.2	1.3	1.2	0.9	0.8	0.7	0.6	0.5	0.5
225	0.8	0.8	0.8	0.9	0.9	1.0	1.0	1.0	0.8	0.7	0.6	0.5	0.5	0.5

Addendum 3

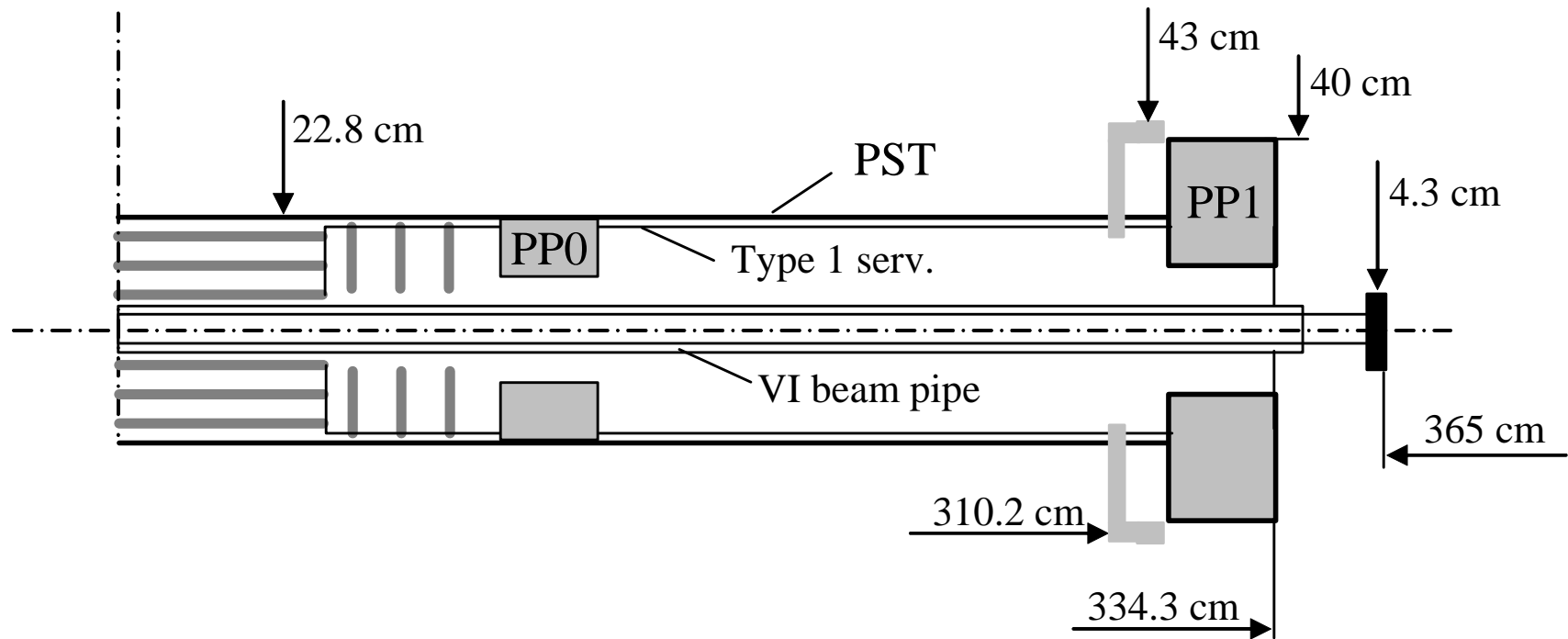

Fig. A3.1 Sketch of the Pixel Detector with VI beam pipe section.

Table A3.1

Equivalent dose rate from Pixel + VI for T= 100d, t= 5d

R/Z, cm	0	50	100	150	200	250	300	325	335	345	365	380	400	425	450
0											72.74	11.49	5.52	3.21	2.16
10										51.62	23.93	10.50	5.41	3.19	2.15
23	36.14	40.52	15.31	7.57	7.10	9.33	31.75	39.93	43.32	30.41	14.15	8.73	5.07	3.08	2.11
30	26.20	25.99	10.86	6.01	5.58	7.67	27.31	32.66	30.85	23.39	11.40	7.59	4.74	2.98	2.07
40	18.34	16.80	8.45	5.10	4.71	6.53	20.60	36.35	21.24	16.27	9.21	6.52	4.33	2.83	2.00
50	13.66	12.15	7.01	4.52	4.18	5.70	14.16	17.66	13.97	11.32	7.49	5.59	3.92	2.66	1.92
75	7.67	6.84	4.85	3.57	3.34	4.18	6.43	6.73	6.35	5.82	4.65	3.86	3.00	2.23	1.69
100	4.96	4.55	3.61	2.92	2.75	3.14	3.85	3.85	3.74	3.57	3.11	2.75	2.30	1.83	1.47
125	3.51	3.30	2.82	2.42	2.29	2.44	2.66	2.60	2.54	2.46	2.25	2.06	1.80	1.51	1.27
150	2.66	2.54	2.27	2.03	1.92	1.95	1.99	1.94	1.90	1.85	1.71	1.61	1.45	1.26	1.10
200	1.71	1.66	1.57	1.46	1.38	1.35	1.29	1.24	1.22	1.20	1.14	1.09	1.01	0.91	0.83
250	1.21	1.20	1.15	1.10	1.05	1.00	0.94	0.90	0.88	0.87	0.83	0.79	0.76	0.71	0.64

Table A3.1 (continuation)

Equivalent dose rate from Pixel + VI for T= 100d, t= 7 d

R/Z, cm	0	50	100	150	200	250	300	325	335	345	365	380	400	425	450
0											67.72	10.62	5.08	2.95	1.99
10										47.28	22.13	9.68	4.98	2.93	1.99
23	32.62	37.18	14.05	7.03	6.61	8.66	29.21	36.67	39.70	27.92	13.05	8.04	4.66	2.84	1.95
30	23.70	23.77	9.96	5.56	5.17	7.10	25.13	30.03	28.29	21.48	10.49	6.99	4.38	2.75	1.91
40	16.61	15.35	7.74	4.71	4.35	6.03	18.95	33.78	19.52	14.96	8.47	6.00	3.99	2.61	1.85
50	12.39	11.09	6.42	4.16	3.86	5.26	13.02	16.28	12.86	10.42	6.89	5.15	3.60	2.45	1.78
75	6.97	6.24	4.44	3.29	3.07	3.85	5.93	6.20	5.84	5.36	4.28	3.55	2.76	2.05	1.56
100	4.52	4.15	3.31	2.67	2.53	2.90	3.54	3.56	3.45	3.29	2.86	2.53	2.12	1.69	1.35
125	3.21	3.01	2.58	2.21	2.10	2.24	2.44	2.39	2.34	2.26	2.07	1.89	1.66	1.39	1.17
150	2.42	2.31	2.07	1.85	1.77	1.80	1.82	1.78	1.74	1.70	1.58	1.49	1.33	1.16	1.00
200	1.56	1.52	1.43	1.34	1.28	1.23	1.19	1.15	1.13	1.11	1.04	1.00	0.93	0.85	0.76
250	1.10	1.08	1.05	1.00	0.95	0.91	0.86	0.82	0.81	0.79	0.76	0.73	0.70	0.65	0.60

Table A3.1 (continuation)

Equivalent dose rate from Pixel + VI for T= 100d, t= 15d

R/Z, cm	0	50	100	150	200	250	300	325	335	345	365	380	400	425	450
0											60.70	9.00	4.23	2.44	1.64
10										38.39	19.05	8.16	4.13	2.43	1.64
23	25.44	30.33	11.46	6.04	5.71	7.38	23.77	29.90	32.42	22.88	10.90	6.71	3.87	2.34	1.60
30	18.55	19.17	8.11	4.70	4.41	5.97	20.40	24.58	23.07	17.62	8.70	5.81	3.62	2.27	1.56
40	13.08	12.32	6.31	3.93	3.67	5.03	15.42	29.37	16.11	12.30	6.99	4.96	3.30	2.16	1.51
50	9.81	8.90	5.22	3.45	3.23	4.37	10.65	13.54	10.65	8.59	5.68	4.24	2.98	2.02	1.45
75	5.55	5.01	3.60	2.70	2.54	3.18	4.87	5.10	4.82	4.41	3.52	2.92	2.27	1.69	1.29
100	3.62	3.34	2.69	2.19	2.07	2.38	2.91	2.91	2.82	2.69	2.36	2.09	1.75	1.39	1.12
125	2.57	2.43	2.09	1.81	1.73	1.84	2.00	1.97	1.92	1.86	1.70	1.56	1.36	1.14	0.96
150	1.96	1.88	1.68	1.52	1.44	1.48	1.51	1.47	1.43	1.39	1.30	1.21	1.09	0.95	0.83
200	1.26	1.23	1.16	1.08	1.04	1.02	0.98	0.94	0.91	0.89	0.85	0.82	0.76	0.69	0.63
250	0.89	0.88	0.86	0.81	0.78	0.75	0.70	0.68	0.66	0.65	0.63	0.61	0.57	0.53	0.49

Table A3.1 (continuation)

Equivalent dose rate from Pixel + VI for T= 100d, t= 30 d

R/Z, cm	0	50	100	150	200	250	300	325	335	345	365	380	400	425	450
0											55.13	7.58	3.47	1.99	1.33
10										30.52	16.41	6.81	3.39	1.97	1.32
23	19.62	24.46	9.17	5.12	4.88	6.17	18.79	23.85	26.05	18.42	9.02	5.54	3.16	1.90	1.30
30	14.37	15.30	6.51	3.91	3.71	4.93	16.07	19.66	18.47	14.15	7.08	4.74	2.95	1.83	1.27
40	10.19	9.78	5.06	3.23	3.03	4.11	12.20	25.32	13.05	9.92	5.68	4.03	2.68	1.74	1.23
50	7.66	7.05	4.19	2.83	2.66	3.55	8.47	11.05	8.66	6.95	4.61	3.44	2.42	1.63	1.18
75	4.38	3.96	2.89	2.19	2.07	2.57	3.91	4.11	3.88	3.55	2.85	2.36	1.85	1.36	1.04
100	2.86	2.65	2.15	1.76	1.68	1.93	2.33	2.34	2.27	2.17	1.90	1.68	1.40	1.12	0.90
125	2.04	1.93	1.68	1.45	1.39	1.49	1.62	1.59	1.55	1.50	1.38	1.25	1.09	0.92	0.77
150	1.55	1.48	1.34	1.21	1.16	1.18	1.21	1.19	1.16	1.12	1.04	0.98	0.88	0.77	0.66
200	1.01	0.98	0.94	0.88	0.83	0.82	0.79	0.75	0.74	0.73	0.69	0.65	0.61	0.56	0.51
250	0.71	0.70	0.68	0.65	0.63	0.61	0.56	0.54	0.53	0.52	0.50	0.48	0.46	0.43	0.40

Table A3.1 (continuation)

Equivalent dose rate from Pixel + VI for T= 100d, t= 100 d

R/Z, cm	0	50	100	150	200	250	300	325	335	345	365	380	400	425	450
0											47.19	5.34	2.23	1.24	0.82
10										18.24	12.33	4.67	2.18	1.23	0.82
23	11.26	15.10	5.44	3.50	3.39	4.07	10.55	14.15	16.08	11.28	6.02	3.66	2.01	1.18	0.80
30	8.29	9.22	3.90	2.58	2.46	3.14	8.90	11.62	11.15	8.58	4.50	3.03	1.86	1.14	0.78
40	5.90	5.82	3.05	2.07	1.97	2.55	6.83	18.24	8.06	6.06	3.54	2.53	1.67	1.08	0.76
50	4.46	4.18	2.53	1.78	1.69	2.18	4.86	6.86	5.35	4.26	2.84	2.15	1.50	1.01	0.73
75	2.57	2.35	1.74	1.35	1.28	1.56	2.31	2.46	2.34	2.16	1.74	1.44	1.12	0.83	0.64
100	1.70	1.58	1.29	1.08	1.03	1.16	1.40	1.41	1.38	1.31	1.15	1.02	0.85	0.68	0.55
125	1.21	1.15	1.00	0.88	0.85	0.90	0.98	0.95	0.93	0.90	0.82	0.76	0.66	0.57	0.47
150	0.92	0.89	0.81	0.74	0.71	0.71	0.73	0.70	0.69	0.67	0.63	0.59	0.54	0.47	0.41
200	0.60	0.59	0.56	0.53	0.51	0.50	0.47	0.45	0.44	0.44	0.42	0.40	0.37	0.34	0.31
250	0.43	0.42	0.41	0.40	0.38	0.36	0.34	0.33	0.32	0.32	0.30	0.29	0.28	0.26	0.24

Table A3.2

Equivalent dose rate from Pixel + VI for T= 10 y, t= 5d

R/Z, cm	0	50	100	150	200	250	300	325	335	345	365	380	400	425	450
0											243.35	26.89	11.11	6.12	4.04
10										91.79	62.71	23.49	10.82	6.06	4.01
23	54.87	71.37	26.24	17.23	16.68	19.96	50.64	69.78	80.64	55.98	30.09	18.24	9.98	5.84	3.93
30	40.19	43.71	18.76	12.58	12.14	15.29	42.48	56.72	55.27	42.31	22.34	15.01	9.18	5.62	3.85
40	28.51	27.76	14.68	10.08	9.62	12.38	32.49	90.70	39.60	29.69	17.45	12.48	8.25	5.31	3.71
50	21.50	20.00	12.16	8.63	8.23	10.55	23.21	33.38	26.12	20.87	13.96	10.52	7.36	4.96	3.55
75	12.34	11.28	8.37	6.52	6.22	7.53	11.17	11.92	11.38	10.50	8.48	7.07	5.52	4.09	3.11
100	8.13	7.56	6.21	5.20	4.99	5.63	6.78	6.84	6.66	6.38	5.61	4.99	4.19	3.33	2.67
125	5.84	5.53	4.83	4.25	4.09	4.35	4.71	4.64	4.54	4.41	4.02	3.70	3.25	2.74	2.28
150	4.45	4.28	3.90	3.55	3.41	3.47	3.54	3.44	3.38	3.29	3.07	2.88	2.60	2.27	1.96
200	2.90	2.84	2.69	2.54	2.45	2.38	2.30	2.22	2.18	2.13	2.02	1.93	1.80	1.65	1.48
250	2.07	2.05	1.98	1.90	1.83	1.74	1.66	1.59	1.57	1.54	1.47	1.42	1.35	1.25	1.16

Table A3.2 (continuation)

Equivalent dose rate from Pixel + VI for T= 10 y, t= 7 d

R/Z, cm	0	50	100	150	200	250	300	325	335	345	365	380	400	425	450
0											237.01	25.92	10.66	5.86	3.86
10										87.36	60.70	22.62	10.38	5.79	3.84
23	51.27	67.93	24.96	16.66	16.17	19.27	48.04	66.42	76.90	53.42	28.90	17.52	9.57	5.59	3.75
30	37.63	41.42	17.85	12.12	11.71	14.70	40.21	54.00	52.61	40.34	21.37	14.39	8.80	5.38	3.67
40	26.75	26.26	13.97	9.67	9.26	11.86	30.79	88.03	37.83	28.33	16.68	11.95	7.89	5.07	3.54
50	20.20	18.90	11.55	8.26	7.90	10.09	22.05	31.97	24.99	19.93	13.34	10.06	7.04	4.74	3.39
75	11.65	10.66	7.94	6.22	5.95	7.20	10.65	11.38	10.85	10.02	8.09	6.75	5.26	3.90	2.96
100	7.67	7.15	5.90	4.96	4.76	5.37	6.46	6.53	6.36	6.08	5.36	4.75	4.00	3.18	2.55
125	5.52	5.24	4.60	4.06	3.91	4.14	4.49	4.42	4.34	4.20	3.84	3.54	3.11	2.61	2.19
150	4.21	4.06	3.69	3.36	3.24	3.30	3.37	3.29	3.21	3.13	2.93	2.75	2.48	2.17	1.87
200	2.74	2.69	2.56	2.42	2.33	2.27	2.19	2.11	2.07	2.02	1.92	1.84	1.72	1.57	1.41
250	1.96	1.93	1.89	1.81	1.74	1.66	1.57	1.51	1.49	1.46	1.40	1.36	1.28	1.19	1.10

Table A3.2 (continuation)

Equivalent dose rate from Pixel + VI for T= 10 y, t= 15d

R/Z, cm	0	50	100	150	200	250	300	325	335	345	365	380	400	425	450
0											232.12	24.35	9.79	5.33	3.49
10										78.23	57.91	21.13	9.52	5.28	3.48
23	43.79	60.69	22.23	15.58	15.21	17.89	42.34	59.33	69.29	48.20	26.77	16.18	8.75	5.08	3.40
30	32.27	36.61	15.90	11.19	10.89	13.49	35.27	48.29	47.16	36.30	19.52	13.17	8.02	4.88	3.33
40	23.07	23.10	12.45	8.84	8.54	10.81	27.11	83.19	34.25	25.56	15.16	10.88	7.18	4.60	3.21
50	17.50	16.61	10.30	7.51	7.23	9.14	19.56	29.07	22.66	18.02	12.09	9.13	6.39	4.30	3.07
75	10.16	9.37	7.05	5.59	5.40	6.49	9.53	10.23	9.77	9.03	7.31	6.11	4.76	3.52	2.69
100	6.73	6.30	5.24	4.44	4.30	4.84	5.80	5.86	5.72	5.48	4.82	4.29	3.61	2.87	2.30
125	4.86	4.62	4.08	3.62	3.50	3.73	4.02	3.98	3.90	3.77	3.46	3.18	2.79	2.35	1.97
150	3.72	3.58	3.28	3.02	2.91	2.97	3.03	2.95	2.89	2.82	2.63	2.47	2.23	1.95	1.68
200	2.44	2.39	2.28	2.16	2.08	2.03	1.96	1.90	1.86	1.82	1.73	1.65	1.55	1.40	1.27
250	1.74	1.72	1.68	1.62	1.55	1.50	1.41	1.36	1.34	1.31	1.26	1.21	1.15	1.07	1.00

Table A3.2 (continuation)

Equivalent dose rate from Pixel + VI for T= 10 y, t= 30 d

R/Z, cm	0	50	100	150	200	250	300	325	335	345	365	380	400	425	450
0											223.03	22.64	8.91	4.82	3.15
10										69.52	54.51	19.53	8.66	4.76	3.12
23	37.49	54.18	19.70	14.51	14.22	16.51	36.89	52.65	62.19	43.20	24.57	14.82	7.95	4.60	3.07
30	27.73	32.33	14.12	10.30	10.07	12.31	30.56	42.86	42.07	32.45	17.69	11.96	7.26	4.41	3.00
40	19.91	20.31	11.07	8.06	7.81	9.77	23.57	78.33	30.83	22.91	13.67	9.83	6.47	4.15	2.88
50	15.17	14.57	9.15	6.80	6.57	8.24	17.16	26.27	20.42	16.18	10.87	8.22	5.75	3.86	2.76
75	8.87	8.22	6.27	5.02	4.86	5.82	8.47	9.12	8.74	8.09	6.55	5.46	4.27	3.16	2.40
100	5.90	5.54	4.64	3.96	3.85	4.31	5.18	5.24	5.11	4.90	4.32	3.84	3.22	2.57	2.06
125	4.27	4.07	3.61	3.23	3.13	3.34	3.60	3.55	3.47	3.36	3.09	2.83	2.50	2.10	1.75
150	3.27	3.16	2.91	2.68	2.59	2.65	2.71	2.63	2.58	2.52	2.35	2.21	2.00	1.74	1.50
200	2.15	2.12	2.01	1.91	1.85	1.81	1.76	1.69	1.66	1.62	1.55	1.48	1.38	1.25	1.13
250	1.54	1.53	1.49	1.43	1.38	1.33	1.25	1.22	1.20	1.17	1.12	1.08	1.03	0.96	0.88

Table A3.2 (continuation)

Equivalent dose rate from Pixel + VI for T= 10 y, t= 100 d

R/Z, cm	0	50	100	150	200	250	300	325	335	345	365	380	400	425	450
0											208.17	19.56	7.32	3.87	2.50
10										54.20	48.48	16.65	7.09	3.82	2.50
23	27.28	42.29	15.07	12.27	12.11	13.70	26.93	40.59	49.50	34.17	20.59	12.33	6.48	3.68	2.44
30	20.28	24.72	10.87	8.51	8.42	9.98	21.97	32.91	32.88	25.45	14.36	9.75	5.87	3.52	2.38
40	14.67	15.40	8.55	6.53	6.40	7.78	17.11	67.98	24.47	18.03	10.94	7.92	5.20	3.30	2.28
50	11.24	11.01	7.07	5.45	5.33	6.49	12.75	20.93	16.22	12.79	8.63	6.56	4.60	3.07	2.18
75	6.65	6.23	4.84	3.96	3.86	4.54	6.50	7.07	6.81	6.32	5.15	4.31	3.38	2.50	1.89
100	4.46	4.20	3.58	3.10	3.02	3.36	4.00	4.06	3.97	3.81	3.39	3.01	2.54	2.03	1.61
125	3.24	3.11	2.79	2.51	2.45	2.59	2.78	2.76	2.71	2.64	2.41	2.22	1.96	1.64	1.38
150	2.49	2.42	2.24	2.08	2.03	2.06	2.10	2.06	2.01	1.96	1.83	1.73	1.56	1.36	1.18
200	1.64	1.63	1.56	1.48	1.44	1.41	1.35	1.32	1.29	1.27	1.21	1.15	1.07	0.98	0.89
250	1.18	1.17	1.15	1.11	1.07	1.02	0.98	0.94	0.92	0.91	0.87	0.84	0.80	0.74	0.69

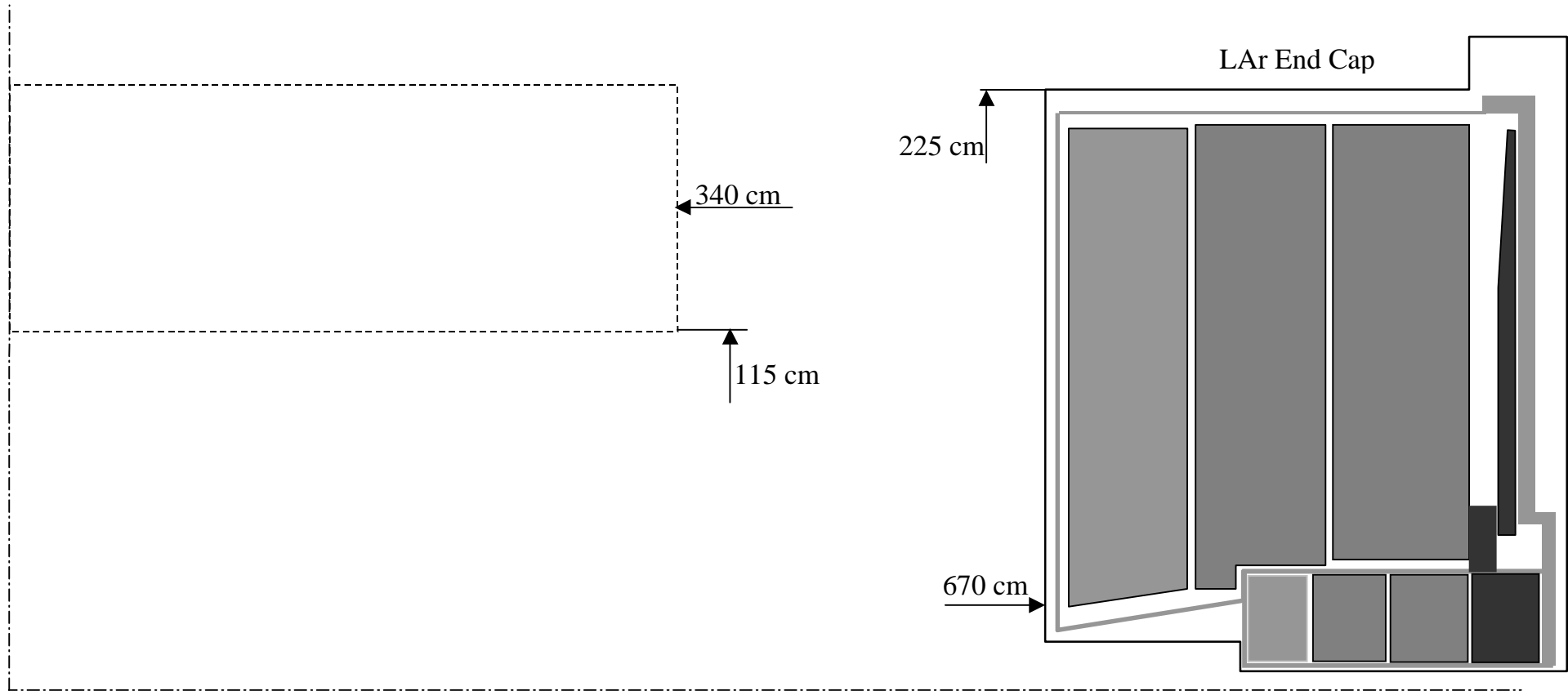

Fig. A4.1. To calculations of dose rate from LAr End Cap.

Table A4.1

Equivalent dose rate from LAr EC calorimeter for T= 100 d, t= 5 d

R/Z, cm	dR\dZ	340	340- 350	350- 365	365- 380	380- 405	405- 430	430- 480	480- 530	530- 580	580- 605	605- 630	630- 645	645- 660	660- 670	670
		0	10	15	15	25	25	50	50	50	25	25	15	15	10	0
0- 5	5	15.5	15.6	16.6	17.9	19.4	21.8	26.5	36.3	54.1	83.1	119.1	155.4	208.9	283.1	317.5
5- 10	5	14.6	14.7	15.5	16.7	18.2	20.6	25	34.4	51.5	78	109	143.1	181.9	232.8	253.6
10- 20	10	13.8	14.2	15	16	17.6	19.8	24.2	33.4	50.5	73.9	97.8	128.2	161.1	198	210.7
20- 30	10	13.1	13.4	14.2	15.1	16.5	18.6	22.8	31.4	47.6	67.2	88.5	113.2	137.3	163.6	173.2
30- 45	15	11.9	12.1	12.8	13.5	14.8	16.6	20.1	27.9	41.1	56.9	75.1	94.7	115.8	138.6	145.5
45- 60	15	10.5	10.7	11.2	12	13	14.6	17.9	24.7	35.8	50.5	64.2	79.2	93.4	109.1	113.1
60- 75	15	9.6	9.7	10.1	10.7	11.6	13.2	16.4	22.6	32.3	43.2	54.1	63.4	71.3	78.5	79.5
75- 95	20	8.5	8.6	9	9.5	10.4	12	15.1	20.2	27.6	36.7	42.2	46.9	49.9	50.7	49.9
95- 115	20	7.5	7.7	8.1	8.7	9.8	11.3	13.6	17.2	23.9	27.9	31.3	31.8	32.3	30.9	29.8
115- 125	10	7.1	7.3	7.8	8.4	9.4	10.5	12.3	15.7	20.6	22.7	24.8	23.3	23.6	21.5	20.3
125- 150	25	6.9	7	7.5	8	8.8	9.6	10.9	14.2	16.5	18.6	17.9	16.8	16.5	14.5	13.7
150- 175	25	6.6	6.7	7	7.3	7.8	8.3	9.6	11.4	12.3	12.8	11.3	10.5	10.1	8.3	8
175- 200	25	6.1	6.2	6.3	6.5	6.8	7.1	7.9	9	9.2	8.6	6.9	6.5	5.9	4.5	4.1
200- 225	25	5.5	5.5	5.5	5.5	5.4	5.7	6.8	7.1	6.7	5.7	4.2	4.2	3.1	2	1.8

Table A4.1 (continuation)

Equivalent dose rate from LAr EC calorimeter for T= 100 d, t= 100 d

R/Z, cm	dR\dZ	340	340- 350	350- 365	365- 380	380- 405	405- 430	430- 480	480- 530	530- 580	580- 605	605- 630	630- 645	645- 660	660- 670	670
		0	10	15	15	25	25	50	50	50	25	25	15	15	10	0
0- 5	5	3.1	3.3	3.5	3.7	4	4.7	5.9	8.4	13.3	20.7	30.5	43.8	61.1	85	94.6
5- 10	5	2.9	2.9	3.2	3.4	3.7	4.3	5.4	7.7	12.2	18.9	27.6	38.9	52.6	69.2	74.5
10- 20	10	2.8	2.8	3	3.3	3.6	4.2	5.2	7.4	11.4	17.3	24.1	33.1	44.8	59.4	64.5
20- 30	10	2.7	2.8	2.9	3.1	3.5	3.9	4.9	6.9	10.4	15	20.6	27.7	35.7	47.2	52.2
30- 45	15	2.5	2.5	2.7	2.9	3.1	3.6	4.4	5.9	8.7	12.3	16.5	21.4	27	33.7	35.9
45- 60	15	2.3	2.3	2.4	2.5	2.8	3.1	3.7	4.9	7.1	10.2	13.5	16.6	19.8	23.1	23.7
60- 75	15	2	2	2.1	2.2	2.4	2.6	3.1	4.2	6.3	8.8	10.8	12.8	14.5	15.8	15.8
75- 95	20	1.7	1.7	1.7	1.8	2	2.1	2.6	3.8	5.5	7.1	8.4	9.2	10	10.2	9.9
95- 115	20	1.3	1.3	1.4	1.4	1.7	1.9	2.6	3.4	4.5	5.5	6.2	6.2	6.7	6.4	5.9
115- 125	10	1.2	1.2	1.3	1.4	1.7	2	2.5	3	3.9	4.6	4.9	4.7	5	4.4	4.2
125- 150	25	1.2	1.2	1.3	1.5	1.7	1.9	2.2	2.5	3.2	3.6	3.6	3.4	3.7	3.1	2.9
150- 175	25	1.3	1.3	1.4	1.5	1.6	1.6	1.7	2.1	2.4	2.6	2.3	2.3	2.4	1.8	1.7
175- 200	25	1.3	1.3	1.3	1.2	1.2	1.2	1.4	1.8	1.8	1.8	1.4	1.6	1.5	1.1	0.9
200- 225	25	1	0.9	0.9	0.9	0.9	1	1.4	1.4	1.4	1.2	0.9	1.2	0.9	0.5	0.4

Table A4.1 (continuation)

Equivalent dose rate from LAr EC calorimeter for T= 10 y, t= 5 d

R/Z, cm	dR\dZ	340	340- 350	350- 365	365- 380	380- 405	405- 430	430- 480	480- 530	530- 580	580- 605	605- 630	630- 645	645- 660	660- 670	670
		0	10	15	15	25	25	50	50	50	25	25	15	15	10	0
0- 5	5	22.9	23.6	24.9	26.6	29.2	32.8	40	55.8	84.5	128.5	186.4	251.1	339.4	458.4	506.6
5- 10	5	21.7	22.1	23.3	24.9	27.4	30.8	37.8	52.9	80.3	121.7	173.4	234.4	305.8	391.1	418.7
10- 20	10	20.7	21.1	22.4	23.9	26.3	29.6	36.3	50.8	77.6	115.3	158	212.8	275.5	351.4	375.8
20- 30	10	19.5	19.9	21.1	22.6	24.7	27.9	34.1	47.6	73	105.5	143	188.4	238.4	303.9	329.8
30- 45	15	17.8	18.1	19.1	20.4	22.3	25	30.6	42.8	64.3	91.4	122.4	158.6	198.7	245.3	257.8
45- 60	15	16.1	16.3	17.1	18.1	19.8	22.3	27.4	38.3	56.5	80.5	104.6	130.1	156.2	183.4	192.3
60- 75	15	14.4	14.8	15.5	16.4	17.8	20.1	25.1	35	51	69.9	87.6	103.5	117.3	129.7	129.7
75- 95	20	12.9	13.1	13.7	14.5	15.9	18.2	23.2	31.5	44.3	58.5	68.7	76.3	82.4	84.6	82.8
95- 115	20	11.3	11.4	12.2	13.1	14.8	17.2	21.1	27.4	37.8	45.6	51	52.4	54.6	52.2	50
115- 125	10	10.6	10.8	11.7	12.8	14.4	16.4	19.5	24.9	32.7	37.3	40.4	39	40.5	36.7	34.7
125- 150	25	10.4	10.6	11.5	12.5	13.7	15.3	17.5	22.1	26.7	30.3	29.7	28.4	29	25.3	23.8
150- 175	25	10.4	10.6	11.1	11.7	12.4	13.2	14.7	18.2	20.1	21.3	18.9	18.3	18.2	14.8	13.9
175- 200	25	9.8	9.8	10.1	10.3	10.5	10.8	12.4	14.7	15.1	14.9	11.7	12.1	11	8	7.4
200- 225	25	8.4	8.4	8.4	8.2	8.3	8.9	11	11.4	11.4	9.8	7.3	8.1	6.1	3.7	3.3

Table A4.1 (continuation)

Equivalent dose rate from LAr EC calorimeter for T= 10 y, t= 100 d

R/Z, cm	dR/dZ	340	340- 350	350- 365	365- 380	380- 405	405- 430	430- 480	480- 530	530- 580	580- 605	605- 630	630- 645	645- 660	660- 670	670
		0	10	15	15	25	25	50	50	50	25	25	15	15	10	0
0- 5	5	10.1	10.3	10.9	11.8	12.8	14.6	18.1	26	40.7	62	90.9	130.9	179.8	239.5	261.4
5- 10	5	9.4	9.5	10.1	10.9	12	13.5	17	24.4	38.2	58.6	85.4	121.1	165.1	211.1	222.4
10- 20	10	9	9.1	9.6	10.4	11.5	12.9	16.2	23.1	36	55	78.5	109.7	149	198.3	213.1
20- 30	10	8.5	8.7	9.2	9.8	10.8	12.3	15.1	21.4	33.3	50.1	70.5	96.5	128.4	178.1	201.7
30- 45	15	7.9	8	8.5	9	9.9	11.2	13.8	19.4	29.9	43.9	60.1	80.1	103.2	132.6	142.4
45- 60	15	7.2	7.3	7.7	8.2	9	10.1	12.4	17.3	26.2	38.1	50.8	64.2	77.7	91.6	94.2
60- 75	15	6.6	6.7	7	7.4	8	9	11.1	15.6	23.5	33.4	41.7	50.1	57.4	63.5	63.5
75- 95	20	5.7	5.8	6.1	6.4	6.9	7.9	10.1	14.3	20.8	27.2	33	36.4	40.2	41.7	40.6
95- 115	20	4.8	4.9	5.2	5.5	6.3	7.4	9.6	12.7	17.3	21.8	24.4	25.3	27.3	26.3	24.8
115- 125	10	4.5	4.6	4.9	5.4	6.3	7.4	9.1	11.4	15.1	18	19.4	19.2	20.7	18.8	17.4
125- 150	25	4.5	4.6	5.1	5.5	6.3	7.1	8.1	9.9	12.8	14.3	14.6	14.1	15.3	13	12.2
150- 175	25	4.8	4.9	5.2	5.5	5.8	6	6.4	8.4	9.7	10.6	9.4	9.6	9.9	7.7	7.3
175- 200	25	4.7	4.7	4.7	4.6	4.6	4.6	5.6	7.2	7.3	7.6	6	6.8	6.2	4.3	4
200- 225	25	3.7	3.6	3.6	3.5	3.5	4	5.3	5.4	5.8	5	3.8	4.8	3.6	2.1	1.9

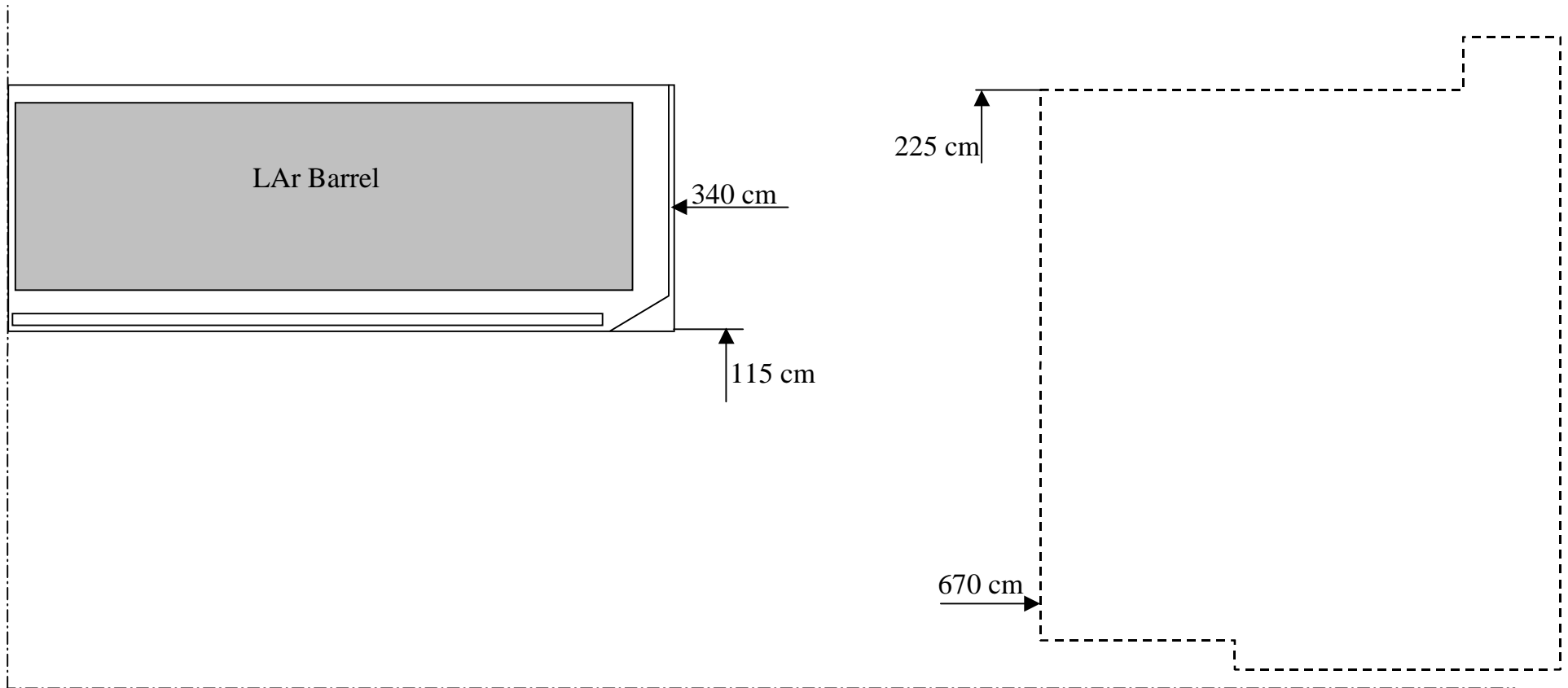

Fig. A4.2. To calculations of dose rate from LAr Barrel.

Table A4.2

Equivalent dose rate from LAr Barrel calorimeter for T= 100 d, t= 5d

R/Z, cm	dR\dZ	340	340- 350	350- 365	365- 380	380- 405	405- 430	430- 480	480- 530	530- 580	580- 605	605- 630	630- 645	645- 660	660- 670	670
		0	10	15	15	25	25	50	50	50	25	25	15	15	10	0
0- 5	5	8.1	7.1	5.8	6.1	6.3	4.1	4.4	3	1.7	1.7					
5- 10	5	8.1	7.1	5.9	6.2	6.3	4.1	4.4	3	1.7	1.7					
10- 20	10	8.1	7.2	5.9	6.1	6.2	4.2	4.4	3	2	1.7					
20- 30	10	8.1	7.3	6	6.2	6	4.6	4.1	3	2.2	1.7					
30- 45	15	8	7.3	6.4	6.2	5.6	5.1	3.9	3.1	2.4	1.6					
45- 60	15	7.8	7.4	6.6	5.9	5.5	5.4	3.7	3.3	2.4	1.5					
60- 75	15	7.8	7.6	6.7	5.8	5.7	5	3.9	3.2	2.4	1.5					
75- 95	20	7.9	7.7	6.8	6.1	5.3	4.9	4	3	2.5	1.5					
95- 115	20	8	7.9	7	5.9	5.2	4.8	3.8	2.8	2.3	1.5					
115- 125	10	8.5	7.9	7.1	6	5.1	4.4	3.8	2.8	2.3	1.6					
125- 150	25	9	7.8	7.1	6	5	4.4	3.7	2.7	2.1	1.6					
150- 175	25	8.5	7.4	6.7	5.7	4.8	3.9	3.4	2.6	2	1.4					
175- 200	25	7.2	6.2	5.9	5.3	4.4	3.8	3.3	2.5	1.9	1.3					
200- 225	25	6	5.1	4.8	4.5	3.7	3.2	2.7	2.2	1.7	1.2					

Table A4.2 (continuation)
 Equivalent dose rate induced by high-energy hadrons from calorimeter for T= 100 d, t= 100 d

R/Z, cm	dR/dZ	340	340- 350	350- 365	365- 380	380- 405	405- 430	430- 480	480- 530	530- 580	580- 605	605- 630	630- 645	645- 660	660- 670	670
		0	10	15	15	25	25	50	50	50	25	25	15	15	10	0
0- 5	5	2.2	2	1.8	1.9	1.6	1.3	1.2	0.9	0.5	0.4					
5- 10	5	2.2	2	1.8	1.9	1.6	1.3	1.2	0.9	0.5	0.4					
10- 20	10	2.2	2	1.9	1.8	1.6	1.3	1.2	0.9	0.5	0.4					
20- 30	10	2.2	2	2	1.8	1.6	1.4	1.2	0.9	0.7	0.4					
30- 45	15	2.3	2.1	1.9	1.8	1.6	1.5	1.1	0.9	0.7	0.4					
45- 60	15	2.3	2.2	2	1.8	1.6	1.5	1.1	0.9	0.7	0.4					
60- 75	15	2.3	2.2	2	1.8	1.6	1.4	1.2	0.8	0.7	0.4					
75- 95	20	2.3	2.3	2.1	1.7	1.5	1.4	1.2	0.8	0.7	0.4					
95- 115	20	2.3	2.2	2	1.7	1.5	1.3	1.1	0.8	0.7	0.4					
115- 125	10	2.5	2.3	2	1.7	1.4	1.2	1.1	0.8	0.6	0.4					
125- 150	25	2.7	2.2	2	1.7	1.4	1.2	1	0.7	0.6	0.4					
150- 175	25	2.3	2	1.8	1.6	1.3	1.1	1	0.7	0.6	0.4					
175- 200	25	2	1.8	1.6	1.5	1.2	1.1	0.9	0.7	0.6	0.4					
200- 225	25	1.9	1.5	1.4	1.3	1.1	0.9	0.8	0.6	0.5	0.3					

Table A4.2 (continuation)
 Equivalent dose rate induced by high-energy hadrons from calorimeter for T= 10 y, t= 5 d

R/Z, cm	dR\ dZ	340	340- 350	350- 365	365- 380	380- 405	405- 430	430- 480	480- 530	530- 580	580- 605	605- 630	630- 645	645- 660	660- 670	670
		0	10	15	15	25	25	50	50	50	25	25	15	15	10	0
0- 5	5	14.2	12.4	10.8	11.1	10.6	7.8	7.5	5.5	3.4	2.8					
5- 10	5	14.1	12.5	10.8	11	10.6	7.8	7.5	5.5	3.4	2.8					
10- 20	10	14.1	12.7	11	11	10.4	7.9	7.5	5.5	3.6	2.8					
20- 30	10	14.1	12.6	11.2	10.9	10.3	8.3	7.3	5.5	3.9	2.8					
30- 45	15	14	12.8	11.5	10.9	9.9	8.9	7.1	5.5	4.2	2.7					
45- 60	15	13.9	13	11.9	10.8	9.8	9.2	6.9	5.7	4.3	2.8					
60- 75	15	14	13.4	12.4	10.6	10	9	7	5.5	4.4	2.9					
75- 95	20	14.3	13.9	12.4	10.9	9.6	8.7	7.1	5.2	4.3	2.8					
95- 115	20	14.4	14.3	12.7	10.8	9.3	8.5	6.6	5.1	4.1	2.8					
115- 125	10	15.8	14.5	12.7	10.7	9.2	7.8	6.6	4.9	3.9	2.7					
125- 150	25	16.8	14.3	12.7	10.8	9	7.7	6.5	4.6	3.7	2.8					
150- 175	25	15.3	13	12	10.2	8.4	7.1	5.9	4.7	3.7	2.7					
175- 200	25	13	11.2	10.7	9.6	8.1	6.9	5.8	4.4	3.3	2.4					
200- 225	25	11.4	9.7	9.1	8.3	7	5.8	4.9	3.9	3.1	2.1					

Table A4.2 (continuation)
 Equivalent dose rate induced by high-energy hadrons from calorimeter for T= 10 y, t= 100 d

R/Z, cm	dR/dZ	340	340- 350	350- 365	365- 380	380- 405	405- 430	430- 480	480- 530	530- 580	580- 605	605- 630	630- 645	645- 660	660- 670	670
		0	10	15	15	25	25	50	50	50	25	25	15	15	10	0
0- 5	5	7.4	7.3	6.9	6.4	6.2	5.6	4.7	4.1	3.1	2	1.4				
5- 10	5	7.4	7.3	6.9	6.4	6.3	5.6	4.7	4.1	3.1	2.1	1.4				
10- 20	10	7.4	7.4	7	6.5	6.2	5.5	4.7	4.1	3.1	2.1	1.4				
20- 30	10	7.4	7.4	7.1	6.6	6.1	5.5	4.8	4	3.1	2.2	1.4				
30- 45	15	7.3	7.5	7.2	6.7	6	5.5	5	3.9	3.1	2.3	1.5				
45- 60	15	7.1	7.6	7.3	6.8	6.1	5.5	5	3.9	3	2.3	1.6				
60- 75	15	7.1	7.7	7.6	7	6.1	5.5	5	4	3	2.4	1.6				
75- 95	20	7.2	8.1	7.9	7.1	6.3	5.4	4.9	3.9	2.9	2.4	1.6				
95- 115	20	7.2	8.2	8.1	7.4	6.2	5.3	4.7	3.7	2.9	2.3	1.5				
115- 125	10	7.6	9.3	8.3	7.2	6.1	5.2	4.3	3.7	2.7	2.1	1.5				
125- 150	25	8	9.8	8.3	7.2	6.1	4.9	4.2	3.6	2.5	2.1	1.5				
150- 175	25	7.4	8.4	7.2	6.6	5.7	4.7	3.9	3.3	2.6	2.2	1.5				
175- 200	25	5.9	7.3	6.3	6	5.4	4.5	3.8	3.2	2.5	1.9	1.3				
200- 225	25	4.5	6.8	5.8	5.3	4.8	4	3.3	2.7	2.2	1.7	1.2				

Addendum 5

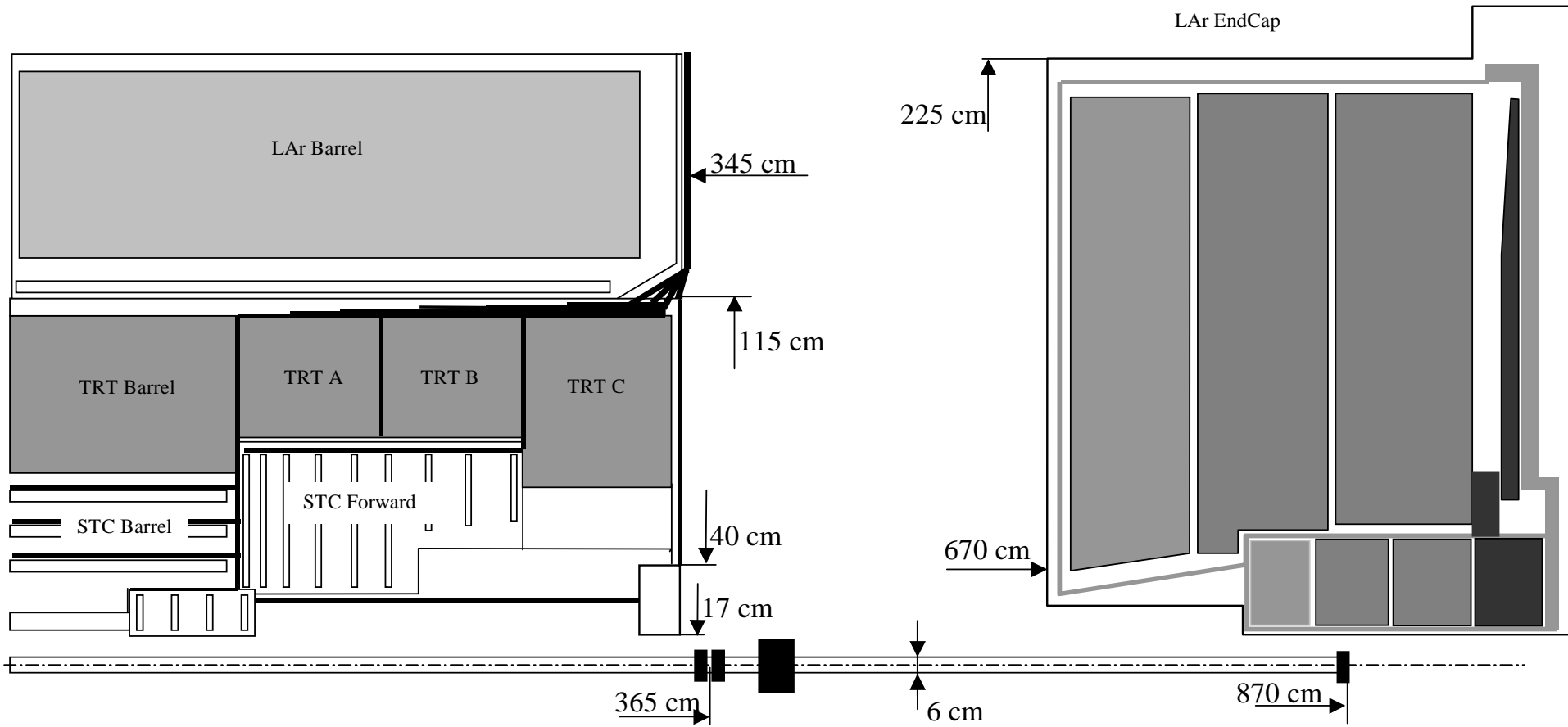

Fig. A5.1 General detector opening layout to calculations of access dose rate.

Table A5.1

Equivalent dose rate in the general access scenario for T= 2 y, t= 1 d

R/Z, cm	dR\dZ	280	280- 290	290- 315	315- 340	340	340- 350	350- 365	365- 380	380- 405	405- 430	430- 480	480- 530	530- 580	580- 630	630- 660	660- 670	670	
		0	10	25	25	0	10	15	15	25	25	50	50	50	50	30	10	0	
0- 5	5																		
5- 10	5					700.7	760.9	1575.0	5564.9	3237.6	2197.5	2901.8	4571.7	4144.0	3594.8	3482.6	3535.7	2141.1	
10- 20	10					626.0	660.0	988.0	1768.9	1526.4	1186.7	1454.6	2088.8	1986.8	1797.5	1819.2	1917.5	1305.5	
20- 30	10					521.8	542.8	668.6	867.6	864.7	774.8	901.0	1187.9	1179.2	1117.1	1170.5	1272.5	985.5	
30- 45	15					453.0	460.9	481.6	539.6	559.1	548.2	615.8	758.1	776.5	765.5	823.2	905.5	720.3	
45- 60	15					395.3	398.1	371.0	384.1	397.9	406.8	446.4	522.0	546.6	557.2	600.2	649.1	516.3	
60- 75	15					324.1	325.1	305.1	305.5	313.0	322.6	349.5	395.9	419.0	431.9	455.0	473.6	362.5	
75- 95	20					272.5	271.9	254.8	250.8	252.9	259.8	278.5	306.2	324.8	333.8	339.0	338.7	245.2	
95- 115	20					257.4	247.7	220.4	210.5	208.7	213.1	224.2	240.7	254.9	256.4	249.6	241.5	166.1	
115- 125	10					240.0	230.3	198.6	187.7	184.7	187.0	194.7	206.5	216.0	213.4	202.9	193.2	128.3	
125- 150	25					191.2	185.0	170.4	164.1	161.5	162.6	167.2	175.3	180.1	174.7	163.0	153.6	99.2	
150- 175	25					149.2	146.0	138.7	135.7	134.0	134.0	136.4	141.6	142.6	133.9	123.5	115.0	71.7	
175- 200	25					119.2	117.4	114.2	112.5	111.8	111.6	113.8	117.0	115.2	105.0	96.4	88.4	52.8	
200- 225	25					97.3	95.6	93.7	93.4	92.1	93.0	96.5	96.7	94.8	84.1	77.3	70.0	40.1	

Table A5.1 (continuation)

Equivalent dose rate in the general access scenario for T= 2 y, t= 5 d

R/Z, cm	dR\dZ	280	280- 290	290- 315	315- 340	340	340- 350	350- 365	365- 380	380- 405	405- 430	430- 480	480- 530	530- 580	580- 630	630- 660	660- 670	670	
		0	10	25	25	0	10	15	15	25	25	50	50	50	50	30	10	0	
0- 5	5																		
5- 10	5					424.3	472.5	1070.5	4053.4	2352.8	1589.2	2111.5	3359.3	3037.1	2605.2	2468.6	2454.6	1402.9	
10- 20	10					371.9	405.7	659.7	1251.6	1086.8	841.8	1043.2	1517.4	1436.1	1274.4	1241.5	1265.0	788.6	
20- 30	10					305.3	326.3	431.5	589.6	597.3	538.0	635.8	850.6	838.9	773.9	771.2	796.3	544.5	
30- 45	15					255.0	265.1	297.8	349.9	372.5	371.4	426.5	533.4	542.0	517.9	527.5	552.0	390.3	
45- 60	15					213.3	218.5	218.6	237.6	254.8	267.8	302.5	359.9	373.3	369.1	378.7	394.9	283.9	
60- 75	15					170.2	173.3	173.0	182.1	194.3	207.4	232.0	267.4	281.2	282.2	286.8	292.1	204.2	
75- 95	20					138.9	140.0	139.3	144.2	152.2	163.0	180.8	202.9	214.1	216.1	215.0	212.1	141.8	
95- 115	20					121.9	120.2	116.0	117.0	122.3	130.4	142.1	156.2	165.6	164.9	159.5	154.3	98.3	
115- 125	10					110.7	109.0	102.9	102.9	106.8	112.7	121.7	132.2	139.3	137.3	130.6	124.9	77.0	
125- 150	25					93.0	91.4	89.5	89.9	92.4	96.6	103.2	111.4	114.8	112.6	105.8	100.5	60.7	
150- 175	25					76.7	75.4	74.6	75.0	76.6	78.8	83.5	88.8	90.3	86.4	80.7	76.5	44.4	
175- 200	25					63.7	62.9	63.1	63.7	64.5	66.1	69.2	72.2	72.4	68.2	63.6	59.8	33.4	
200- 225	25					54.4	53.4	53.3	53.7	54.0	55.4	58.2	59.7	59.4	54.9	51.2	47.8	25.7	

Table A5.1 (continuation)

Equivalent dose rate in the general access scenario for T= 2 y, t= 15 d

R/Z, cm	dR\dZ	280	280- 290	290- 315	315- 340	340	340- 350	350- 365	365- 380	380- 405	405- 430	430- 480	480- 530	530- 580	580- 630	630- 660	660- 670	670	
		0	10	25	25	0	10	15	15	25	25	50	50	50	50	30	10	0	
0- 5	5																		
5- 10	5					284.8	313.5	687.2	2576.4	1488.2	1005.7	1344.3	2162.4	1954.2	1670.1	1583.9	1585.3	925.8	
10- 20	10					250.4	269.1	426.0	798.3	690.5	535.2	666.7	976.9	923.8	818.7	802.5	827.9	534.6	
20- 30	10					205.1	217.3	281.0	378.5	381.7	344.0	407.6	548.2	540.1	497.5	499.6	524.2	372.5	
30- 45	15					173.7	179.5	196.0	226.9	239.9	238.5	274.3	343.9	348.9	332.7	340.1	358.1	259.4	
45- 60	15					147.4	150.3	145.4	155.2	165.8	173.0	194.8	231.7	240.1	236.9	243.3	253.8	183.4	
60- 75	15					117.0	118.4	115.2	119.9	126.9	134.3	149.6	171.9	180.8	181.0	183.7	187.1	130.9	
75- 95	20					94.8	95.9	93.2	95.5	99.7	105.7	116.6	130.7	137.7	138.7	137.6	135.7	90.9	
95- 115	20					83.6	82.2	77.8	77.8	80.3	85.0	92.3	100.9	106.4	105.8	102.2	98.9	63.2	
115- 125	10					76.2	74.7	69.2	68.2	70.2	73.6	79.2	85.4	89.6	88.2	83.8	80.1	49.7	
125- 150	25					63.3	62.3	60.0	59.9	60.9	63.5	67.1	72.0	74.3	72.3	67.9	64.6	39.1	
150- 175	25					51.7	50.6	49.9	50.0	50.5	52.0	54.3	57.5	58.3	55.8	52.0	49.0	28.8	
175- 200	25					43.3	42.1	42.1	42.3	42.6	43.3	45.2	47.1	47.0	43.9	41.1	38.4	21.6	
200- 225	25					36.4	35.6	35.6	35.7	35.6	36.4	38.2	38.7	38.8	35.5	33.0	30.7	16.7	

Table A5.1 (continuation)

Equivalent dose rate in the general access scenario for T= 2 y, t= 30 d

R/Z, cm	dR\dZ	280	280- 290	290- 315	315- 340	340	340- 350	350- 365	365- 380	380- 405	405- 430	430- 480	480- 530	530- 580	580- 630	630- 660	660- 670	670	
		0	10	25	25	0	10	15	15	25	25	50	50	50	50	30	10	0	
0- 5	5																		
5- 10	5					210.8	229.5	487.0	1799.6	1030.6	695.6	940.0	1530.2	1377.8	1166.6	1110.9	1121.0	667.3	
10- 20	10					185.2	196.3	302.3	558.6	480.8	372.6	467.6	691.4	652.1	574.8	567.2	593.8	394.9	
20- 30	10					151.3	158.6	201.1	266.8	268.1	241.1	286.8	387.7	381.5	350.0	354.5	377.8	279.4	
30- 45	15					129.6	133.0	141.6	161.6	169.8	168.4	193.6	243.4	246.5	234.3	241.2	257.0	189.7	
45- 60	15					111.8	113.4	105.9	111.9	118.1	122.8	138.1	163.9	169.5	166.9	172.0	179.4	130.8	
60- 75	15					88.1	89.2	84.6	86.8	90.8	95.8	106.1	121.5	127.6	127.5	129.5	131.5	92.7	
75- 95	20					71.2	71.6	68.9	69.3	71.8	75.5	82.5	92.6	97.5	97.5	96.9	95.6	64.5	
95- 115	20					62.9	61.6	57.4	56.6	57.9	61.0	65.6	71.7	75.1	74.4	72.2	69.5	44.8	
115- 125	10					57.7	56.1	51.1	50.0	50.8	52.8	56.6	60.5	63.3	62.0	59.2	56.3	35.1	
125- 150	25					47.5	46.3	44.2	43.9	44.1	45.6	47.9	51.0	52.6	51.1	48.2	45.5	27.8	
150- 175	25					38.5	37.7	36.8	36.8	37.1	37.3	38.8	41.2	41.5	39.6	36.9	34.5	20.4	
175- 200	25					32.1	31.3	31.1	31.0	30.8	31.2	32.4	33.6	33.3	31.2	29.1	27.1	15.4	
200- 225	25					27.2	26.3	25.7	25.9	26.0	26.3	27.5	27.8	27.6	25.3	23.4	21.6	11.9	

Table A5.1 (continuation)

Equivalent dose rate in the general access scenario for T= 2 y, t= 100 d

R/Z, cm	dR\dZ	280	280- 290	290- 315	315- 340	340	340- 350	350- 365	365- 380	380- 405	405- 430	430- 480	480- 530	530- 580	580- 630	630- 660	660- 670	670	
		0	10	25	25	0	10	15	15	25	25	50	50	50	50	30	10	0	
0- 5	5																		
5- 10	5					119.6	129.5	264.2	942.4	530.4	355.3	487.5	805.9	720.5	608.2	585.6	596.1	366.7	
10- 20	10					106.7	110.6	163.9	294.6	250.4	193.0	244.2	364.9	343.0	303.3	306.3	328.3	229.7	
20- 30	10					87.0	89.2	109.8	142.6	141.2	126.3	151.0	205.3	201.7	186.9	195.6	218.4	179.3	
30- 45	15					75.1	76.4	78.3	87.7	90.7	89.4	103.0	129.2	131.5	126.6	134.8	148.9	119.5	
45- 60	15					65.3	66.2	59.8	61.8	63.9	65.8	74.1	87.5	91.0	90.8	96.2	102.7	79.4	
60- 75	15					51.6	52.1	48.2	48.4	49.8	52.0	57.2	65.4	69.0	69.8	72.4	74.6	55.4	
75- 95	20					42.2	42.0	39.5	39.3	39.6	41.5	44.9	50.1	53.1	53.6	53.8	53.9	38.3	
95- 115	20					37.3	36.2	33.2	32.3	32.4	33.4	36.1	39.2	41.1	41.0	40.1	38.9	26.1	
115- 125	10					34.0	33.0	29.3	28.5	28.6	29.4	31.4	33.2	34.7	34.2	32.6	31.3	20.4	
125- 150	25					28.2	27.1	25.9	25.1	25.0	25.8	26.8	28.0	29.1	28.1	26.5	25.1	16.1	
150- 175	25					22.9	22.5	21.6	21.1	20.9	21.0	21.6	22.7	22.9	21.6	20.2	18.9	11.8	
175- 200	25					18.9	18.4	18.0	18.0	17.6	17.7	18.3	18.8	18.4	17.1	16.1	14.5	8.5	
200- 225	25					15.9	15.5	15.0	14.8	15.0	14.9	15.5	15.5	15.2	13.6	12.9	11.5	6.5	

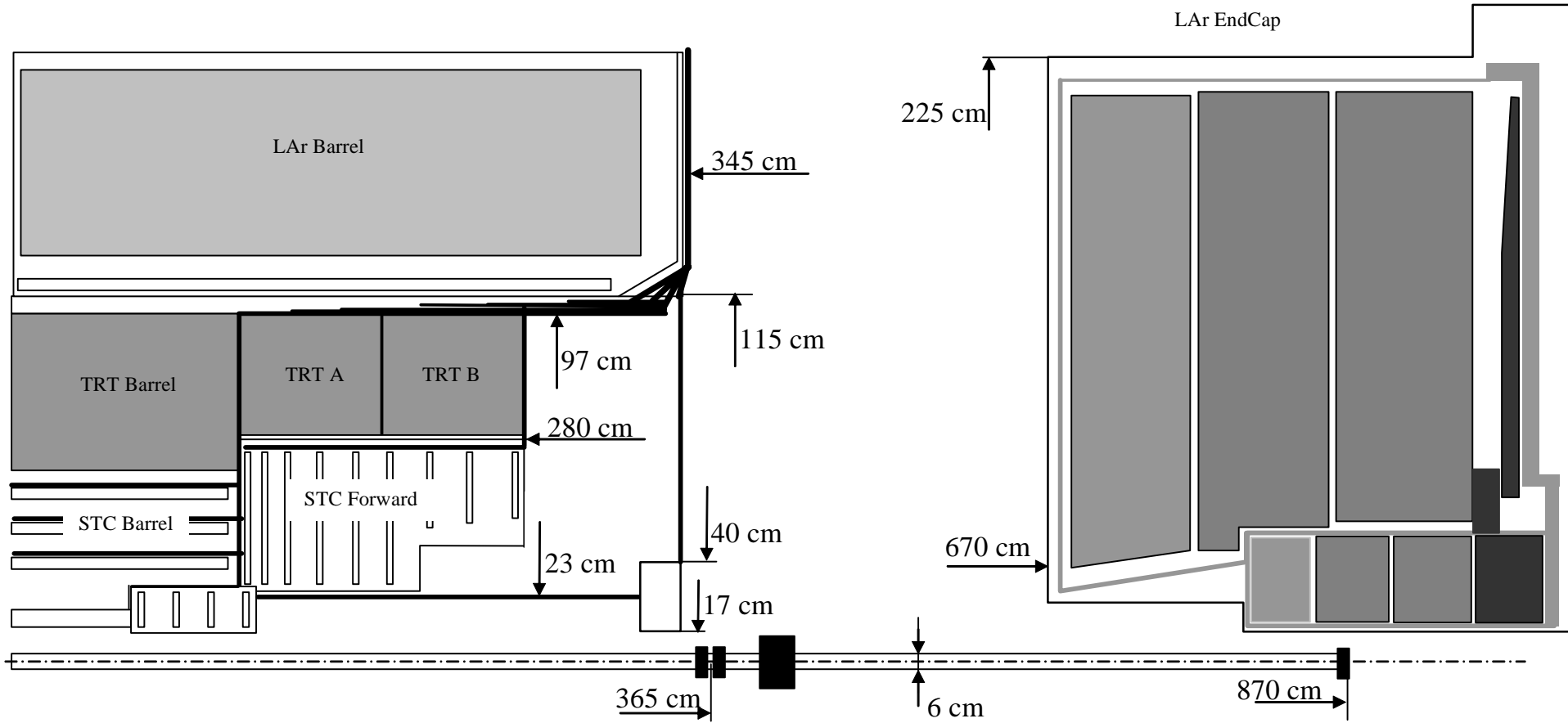

Fig. A5.2 Detector opening layout to calculations of access dose rate – TRT C removed.

Table A5.2

Equivalent dose rate in the general access scenario for T= 2 y, t= 1 d – TRT C removed

R/Z, cm	dR\dZ	280	280- 290	290- 315	315- 340	340	340- 350	350- 365	365- 380	380- 405	405- 430	430- 480	480- 530	530- 580	580- 630	630- 660	660- 670	670	
		0	10	25	25	0	10	15	15	25	25	50	50	50	50	30	10	0	
0- 5	5																		
5- 10	5					699.3	759.5	1573.8	5563.9	3236.8	2197.0	2901.4	4571.5	4143.8	3594.7	3482.5	3535.6	2141.3	
10- 20	10					624.5	658.6	986.8	1767.9	1525.6	1186.2	1454.2	2088.6	1986.6	1797.4	1819.1	1917.4	1305.7	
20- 30	10					520.1	541.4	667.4	866.6	863.9	774.3	900.6	1187.7	1179.0	1117.0	1170.4	1272.4	985.7	
30- 45	15					451.1	459.2	480.2	538.6	558.3	547.7	615.5	757.9	776.3	765.4	823.1	905.4	720.5	
45- 60	15					392.9	396.0	369.7	383.1	397.1	406.4	446.1	521.8	546.4	557.1	600.2	649.0	516.5	
60- 75	15					321.6	323.0	303.7	304.5	312.3	322.2	349.2	395.7	418.8	431.8	455.0	473.5	362.7	
75- 95	20					270.4	270.1	253.6	249.9	252.4	259.3	278.1	306.1	324.6	333.7	339.0	338.6	245.4	
95- 115	20					256.0	246.4	219.5	209.8	208.1	212.7	224.0	240.5	254.7	256.3	249.6	241.4	166.3	
115- 125	10					239.1	229.4	197.8	187.1	184.3	186.6	194.4	206.2	215.9	213.3	202.9	193.1	128.5	
125- 150	25					190.6	184.3	169.8	163.7	161.2	162.2	167.0	175.1	180.0	174.6	163.0	153.5	99.4	
150- 175	25					148.8	145.5	138.2	135.4	133.8	133.7	136.3	141.5	142.5	133.8	123.4	114.9	71.9	
175- 200	25					119.0	117.1	113.9	112.3	111.6	111.4	113.6	116.9	115.1	104.8	96.3	88.3	53.0	
200- 225	25					97.0	95.3	93.5	93.2	92.0	92.9	96.4	96.5	94.7	84.1	77.2	69.9	40.3	

Table A5.2 (continuation)

Equivalent dose rate in the general access scenario for T= 2 y, t= 5 d – TRT C removed

R/Z, cm	dR\dZ	280	280- 290	290- 315	315- 340	340	340- 350	350- 365	365- 380	380- 405	405- 430	430- 480	480- 530	530- 580	580- 630	630- 660	660- 670	670	
		0	10	25	25	0	10	15	15	25	25	50	50	50	50	30	10	0	
0- 5	5																		
5- 10	5					423.9	472.1	1070.3	4053.2	2352.7	1589.1	2111.4	3359.3	3037.1	2605.2	2468.6	2454.6	1403.0	
10- 20	10					371.5	405.3	659.5	1251.4	1086.7	841.7	1043.1	1517.4	1436.1	1274.4	1241.5	1265.0	788.7	
20- 30	10					304.9	325.9	431.3	589.4	597.2	537.9	635.7	850.6	838.9	773.9	771.2	796.3	544.6	
30- 45	15					254.5	264.7	297.6	349.7	372.4	371.3	426.4	533.4	542.0	517.9	527.5	552.0	390.4	
45- 60	15					212.7	218.0	218.3	237.3	254.7	267.7	302.4	359.8	373.3	369.1	378.7	394.9	284.0	
60- 75	15					169.5	172.8	172.7	181.8	194.2	207.3	231.9	267.3	281.2	282.2	286.8	292.1	204.3	
75- 95	20					138.4	139.6	139.1	143.9	152.1	162.9	180.8	202.8	214.1	216.1	215.0	212.1	141.9	
95- 115	20					121.5	120.0	115.8	116.9	122.2	130.3	142.1	156.1	165.6	164.9	159.5	154.3	98.4	
115- 125	10					110.4	108.8	102.7	102.8	106.8	112.6	121.7	132.1	139.3	137.3	130.6	124.9	77.1	
125- 150	25					92.7	91.3	89.4	89.8	92.3	96.4	103.2	111.3	114.8	112.6	105.8	100.5	60.8	
150- 175	25					76.5	75.3	74.6	74.9	76.5	78.8	83.4	88.7	90.2	86.4	80.7	76.5	44.6	
175- 200	25					63.7	62.9	63.0	63.6	64.4	66.1	69.2	72.1	72.4	68.2	63.6	59.8	33.6	
200- 225	25					54.3	53.2	53.2	53.7	54.0	55.3	58.1	59.7	59.4	54.9	51.2	47.8	25.9	

Table A5.2 (continuation)

Equivalent dose rate in the general access scenario for T= 2 y, t= 15 d – TRT C removed

R/Z, cm	dR\dZ	280	280- 290	290- 315	315- 340	340	340- 350	350- 365	365- 380	380- 405	405- 430	430- 480	480- 530	530- 580	580- 630	630- 660	660- 670	670	
		0	10	25	25	0	10	15	15	25	25	50	50	50	50	30	10	0	
0- 5	5																		
5- 10	5					284.8	313.5	687.1	2576.3	1488.2	1005.6	1344.3	2162.4	1954.2	1670.1	1583.9	1585.3	925.9	
10- 20	10					250.4	269.1	425.9	798.2	690.5	535.1	666.7	976.9	923.8	818.7	802.5	827.9	534.7	
20- 30	10					205.1	217.3	280.9	378.4	381.7	343.9	407.6	548.2	540.1	497.5	499.6	524.2	372.6	
30- 45	15					173.6	179.5	195.9	226.8	239.9	238.5	274.3	343.9	348.9	332.7	340.1	358.1	259.5	
45- 60	15					147.3	150.2	145.4	155.1	165.8	173.0	194.8	231.7	240.1	236.9	243.3	253.8	183.5	
60- 75	15					116.9	118.4	115.2	119.8	126.9	134.3	149.5	171.9	180.8	181.0	183.7	187.1	131.0	
75- 95	20					94.8	95.8	93.2	95.5	99.7	105.7	116.6	130.7	137.7	138.7	137.6	135.7	91.0	
95- 115	20					83.6	82.2	77.6	77.8	80.3	85.0	92.3	100.9	106.4	105.8	102.2	98.9	63.3	
115- 125	10					76.1	74.7	69.1	68.2	70.2	73.6	79.2	85.4	89.6	88.2	83.8	80.1	49.8	
125- 150	25					63.2	62.2	60.0	59.9	60.8	63.5	67.1	72.0	74.3	72.3	67.9	64.6	39.2	
150- 175	25					51.6	50.6	49.9	49.9	50.5	52.0	54.3	57.5	58.3	55.8	52.0	49.0	28.9	
175- 200	25					43.2	42.1	42.1	42.3	42.6	43.3	45.2	47.1	47.0	43.9	41.1	38.4	21.7	
200- 225	25					36.4	35.6	35.6	35.6	35.6	36.4	38.2	38.7	38.7	35.5	33.0	30.7	16.8	

Table A5.2 (continuation)

Equivalent dose rate in the general access scenario for T= 2 y, t= 30 d – TRT C removed

R/Z, cm	dR\dZ	280	280- 290	290- 315	315- 340	340	340- 350	350- 365	365- 380	380- 405	405- 430	430- 480	480- 530	530- 580	580- 630	630- 660	660- 670	670	
		0	10	25	25	0	10	15	15	25	25	50	50	50	50	30	10	0	
0- 5	5																		
5- 10	5					210.8	229.5	487.0	1799.6	1030.6	695.6	940.0	1530.2	1377.8	1166.6	1110.9	1121.0	667.4	
10- 20	10					185.2	196.3	302.3	558.6	480.8	372.6	467.6	691.4	652.1	574.8	567.2	593.8	395.0	
20- 30	10					151.2	158.6	201.1	266.8	268.1	241.1	286.8	387.7	381.5	350.0	354.5	377.8	279.5	
30- 45	15					129.5	132.9	141.6	161.6	169.8	168.4	193.6	243.4	246.5	234.3	241.2	257.0	189.8	
45- 60	15					111.8	113.3	105.9	111.9	118.1	122.8	138.1	163.9	169.5	166.9	172.0	179.4	130.9	
60- 75	15					88.1	89.2	84.6	86.7	90.8	95.8	106.1	121.5	127.6	127.5	129.5	131.5	92.8	
75- 95	20					71.2	71.6	68.8	69.2	71.8	75.5	82.5	92.6	97.5	97.5	96.9	95.6	64.6	
95- 115	20					62.9	61.6	57.4	56.6	57.8	61.0	65.6	71.6	75.1	74.4	72.2	69.5	44.9	
115- 125	10					57.6	56.1	51.1	50.0	50.8	52.8	56.6	60.5	63.3	62.0	59.2	56.3	35.2	
125- 150	25					47.5	46.3	44.2	43.9	44.1	45.6	47.9	51.0	52.6	51.1	48.2	45.5	27.9	
150- 175	25					38.5	37.7	36.8	36.8	37.1	37.3	38.8	41.2	41.5	39.6	36.9	34.5	20.5	
175- 200	25					32.1	31.3	31.1	31.0	30.8	31.2	32.4	33.6	33.3	31.2	29.1	27.1	15.5	
200- 225	25					27.1	26.3	25.7	25.9	26.0	26.3	27.5	27.8	27.6	25.3	23.4	21.6	12.0	

Table A5.2 (continuation)
 Equivalent dose rate in the general access scenario for T= 2y, t= 100 d – TRT C removed

R/Z, cm	dR\dZ	280	280- 290	290- 315	315- 340	340	340- 350	350- 365	365- 380	380- 405	405- 430	430- 480	480- 530	530- 580	580- 630	630- 660	660- 670	670	
		0	10	25	25	0	10	15	15	25	25	50	50	50	50	30	10	0	
0- 5	5																		
5- 10	5					119.6	129.5	264.2	942.4	530.4	355.3	487.5	805.9	720.5	608.2	585.6	596.1	366.8	
10- 20	10					106.7	110.6	163.9	294.6	250.4	193.0	244.2	364.9	343.0	303.3	306.3	328.3	229.8	
20- 30	10					87.0	89.2	109.8	142.6	141.2	126.3	151.0	205.3	201.7	186.9	195.6	218.4	179.4	
30- 45	15					75.1	76.4	78.3	87.7	90.7	89.4	103.0	129.2	131.5	126.6	134.8	148.9	119.6	
45- 60	15					65.3	66.1	59.8	61.7	63.9	65.8	74.1	87.5	91.0	90.8	96.2	102.7	79.5	
60- 75	15					51.6	52.1	48.2	48.4	49.8	52.0	57.2	65.4	69.0	69.8	72.4	74.6	55.5	
75- 95	20					42.2	42.0	39.5	39.3	39.6	41.5	44.9	50.1	53.1	53.6	53.8	53.9	38.4	
95- 115	20					37.3	36.2	33.2	32.3	32.4	33.4	36.1	39.2	41.1	41.0	40.1	38.9	26.2	
115- 125	10					34.0	33.0	29.3	28.5	28.6	29.4	31.4	33.2	34.7	34.2	32.6	31.3	20.5	
125- 150	25					28.2	27.1	25.9	25.1	25.0	25.8	26.7	28.0	29.1	28.1	26.5	25.1	16.2	
150- 175	25					22.9	22.5	21.6	21.1	20.9	21.0	21.6	22.7	22.9	21.6	20.2	18.9	11.9	
175- 200	25					18.9	18.4	18.0	18.0	17.6	17.7	18.3	18.8	18.4	17.1	16.1	14.5	8.6	
200- 225	25					15.9	15.5	15.0	14.8	15.0	14.9	15.5	15.5	15.2	13.6	12.9	11.5	6.5	

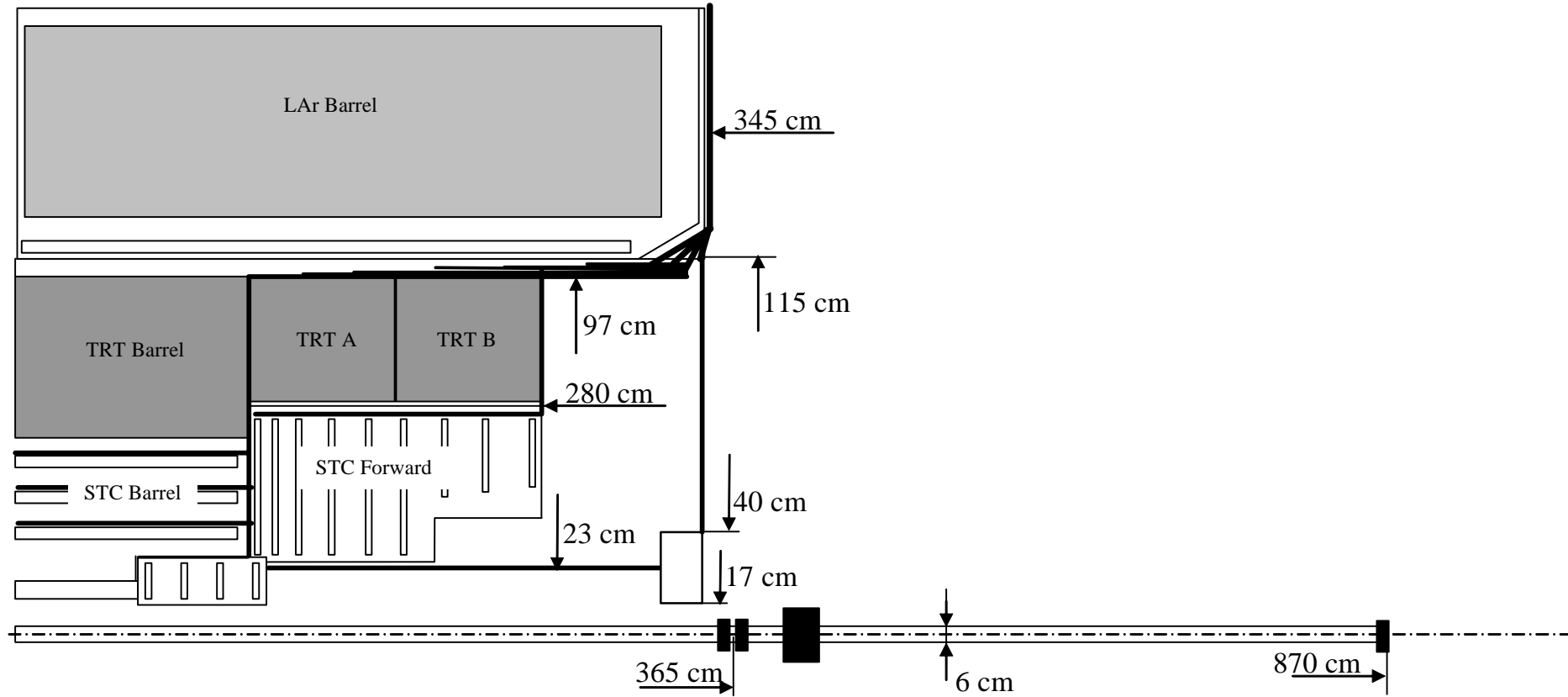

Fig. A5.3. Detector opening layout to calculations of access dose rate – TRT C, LAr EndCap removed.

Table A5.3

Equivalent dose rate in the ID access scenario for T= 2 y, t= 1 d – TRT C, LAr EndCap removed

R/Z, cm	dR\dZ	280	280- 290	290- 315	315- 340	340	340- 350	350- 365	365- 380	380- 405	405- 430	430- 480	480- 530	530- 580	580- 630	630- 660	660- 670	670
		0	10	25	25	0	10	15	15	25	25	50	50	50	50	30	10	0
0- 5	5																	
5- 10	5					666.1	725.8	1538.2	5525.8	3195.0	2149.9	2843.6	4491.0	4022.0	3369.0	3066.3	2923.1	1454.7
10- 20	10					593.0	626.4	952.9	1731.5	1485.6	1141.1	1398.8	2011.2	1868.3	1587.2	1440.3	1371.6	683.1
20- 30	10					490.4	511.2	635.4	832.4	826.4	732.1	848.7	1115.2	1067.3	924.8	837.6	797.6	399.7
30- 45	15					424.0	431.7	451.2	507.7	524.5	509.7	568.9	692.5	677.4	598.4	542.8	517.4	260.6
45- 60	15					368.4	371.1	343.6	355.4	366.8	372.4	404.2	463.0	458.7	412.4	375.5	358.8	181.9
60- 75	15					299.4	300.5	280.0	279.4	285.0	291.4	310.6	341.6	339.3	309.2	282.5	270.7	138.2
75- 95	20					250.5	249.9	232.6	227.6	227.9	231.2	242.4	257.2	256.1	235.3	216.1	207.7	106.6
95- 115	20					238.6	228.7	200.8	189.6	185.4	186.2	191.3	198.1	196.4	181.8	167.5	161.3	83.6
115- 125	10					222.7	212.8	179.9	167.5	162.3	161.3	164.1	167.7	165.6	153.5	142.1	137.1	71.6
125- 150	25					174.2	167.9	152.2	144.6	140.0	138.5	140.0	141.0	138.9	128.7	119.4	115.2	60.5
150- 175	25					132.9	129.0	121.0	117.1	114.5	113.3	113.6	113.6	111.6	103.1	95.8	92.9	49.5
175- 200	25					103.8	101.8	98.1	96.3	95.3	94.7	94.7	94.3	91.9	84.5	78.9	76.5	41.3
200- 225	25					83.9	82.2	80.7	80.6	79.5	79.3	79.5	78.8	77.3	71.0	66.4	64.5	35.2

Table A5.3 (continuation)

Equivalent dose rate in the ID access scenario for T= 2 y, t= 5 d – TRT C, LAr EndCap removed

R/Z, cm	dR\dZ	280	280- 290	290- 315	315- 340	340	340- 350	350- 365	365- 380	380- 405	405- 430	430- 480	480- 530	530- 580	580- 630	630- 660	660- 670	670	
		0	10	25	25	0	10	15	15	25	25	50	50	50	50	30	10	0	
0- 5	5																		
5- 10	5					407.0	454.9	1052.2	4033.8	2331.4	1565.2	2082.1	3318.7	2975.7	2493.3	2269.6	2166.0	1073.8	
10- 20	10					355.4	388.9	642.1	1232.7	1066.2	818.6	1014.9	1478.2	1376.5	1171.7	1064.1	1016.4	505.3	
20- 30	10					289.6	310.3	414.8	571.8	577.8	516.2	609.2	813.7	782.8	680.9	617.8	588.9	293.8	
30- 45	15					240.5	250.5	282.7	333.9	355.1	351.9	402.7	500.6	493.4	438.9	399.3	381.2	190.6	
45- 60	15					200.3	205.4	205.1	223.2	239.5	250.6	281.4	330.8	331.0	300.8	275.2	263.1	132.0	
60- 75	15					158.4	161.5	160.8	169.3	180.5	191.9	212.8	241.0	243.0	224.3	206.4	198.1	99.7	
75- 95	20					128.5	129.6	128.7	132.8	139.9	148.9	163.1	179.0	181.4	169.3	157.2	151.1	76.4	
95- 115	20					112.8	111.2	106.4	106.8	110.9	117.3	126.1	135.8	137.5	129.6	121.0	117.1	59.5	
115- 125	10					102.2	100.5	93.7	93.1	95.9	100.3	107.1	113.6	114.9	108.9	102.2	98.9	50.3	
125- 150	25					84.7	83.1	80.7	80.4	82.0	85.1	90.2	94.7	95.3	90.8	85.5	82.8	42.4	
150- 175	25					68.7	67.4	66.3	66.2	67.3	69.0	72.3	75.2	75.5	72.0	68.1	66.3	34.0	
175- 200	25					56.5	55.6	55.6	55.9	56.5	57.9	59.9	61.5	61.4	58.8	55.8	54.3	28.0	
200- 225	25					47.9	46.8	46.8	47.4	47.7	48.6	50.0	51.3	51.3	48.9	46.6	45.3	23.5	

Table A5.3 (continuation)
 Equivalent dose rate in the ID access scenario for T= 2 y, t= 15 d – TRT C, LAr EndCap removed

R/Z, cm	dR\dZ	280	280- 290	290- 315	315- 340	340	340- 350	350- 365	365- 380	380- 405	405- 430	430- 480	480- 530	530- 580	580- 630	630- 660	660- 670	670	
		0	10	25	25	0	10	15	15	25	25	50	50	50	50	30	10	0	
0- 5	5																		
5- 10	5					273.9	302.3	675.2	2563.5	1474.2	989.7	1324.7	2134.9	1911.8	1591.7	1438.5	1370.7	680.8	
10- 20	10					239.7	258.3	414.4	786.0	676.9	519.8	647.9	950.4	883.2	747.5	675.7	643.4	320.2	
20- 30	10					195.0	207.0	270.0	366.7	368.9	329.4	389.8	523.3	502.4	434.3	392.6	373.6	186.4	
30- 45	15					164.3	170.1	185.9	216.3	228.4	225.5	258.4	322.1	316.7	280.1	253.8	241.8	121.1	
45- 60	15					139.0	141.8	136.5	145.8	155.6	161.7	181.0	212.9	212.7	192.2	175.1	167.5	84.2	
60- 75	15					109.4	110.8	107.4	111.5	117.9	124.3	137.3	155.2	156.2	143.5	131.6	126.1	63.6	
75- 95	20					88.3	89.2	86.4	88.3	91.9	97.0	105.6	115.5	116.6	108.6	100.3	96.3	48.8	
95- 115	20					78.1	76.6	71.8	71.5	73.3	76.8	82.1	87.7	88.6	83.1	77.4	74.6	38.0	
115- 125	10					71.0	69.5	63.6	62.2	63.4	65.7	69.7	73.6	74.1	69.9	65.3	63.1	32.3	
125- 150	25					58.3	57.2	54.5	53.9	54.2	56.0	58.8	61.5	61.6	58.3	54.6	52.9	27.1	
150- 175	25					46.6	45.5	44.4	44.2	44.5	45.7	47.3	48.9	48.9	46.3	43.6	42.2	21.8	
175- 200	25					38.4	37.3	37.3	37.4	37.6	38.2	39.4	40.1	39.9	37.7	35.8	34.7	18.0	
200- 225	25					32.4	31.6	31.7	31.7	31.8	32.2	32.9	33.4	33.4	31.5	29.7	29.0	15.1	

Table A5.3 (continuation)
 Equivalent dose rate in the ID access scenario for T= 2 y, t= 30 d – TRT C, LAr EndCap removed

R/Z, cm	dR\dZ	280	280- 290	290- 315	315- 340	340	340- 350	350- 365	365- 380	380- 405	405- 430	430- 480	480- 530	530- 580	580- 630	630- 660	660- 670	670	
		0	10	25	25	0	10	15	15	25	25	50	50	50	50	30	10	0	
0- 5	5																		
5- 10	5					202.8	221.4	478.4	1790.4	1020.4	684.1	925.6	1509.7	1345.8	1106.5	996.1	947.7	470.8	
10- 20	10					177.6	188.5	294.0	549.7	471.0	361.5	453.7	671.8	621.8	520.9	468.1	445.4	221.8	
20- 30	10					143.8	151.1	193.2	258.3	258.7	230.5	273.7	369.4	353.7	302.8	272.4	258.9	129.4	
30- 45	15					122.7	126.0	134.4	153.8	161.3	158.8	182.0	227.4	223.0	195.5	176.6	168.0	84.0	
45- 60	15					105.7	107.1	99.5	105.0	110.6	114.4	128.0	150.4	149.7	134.4	122.1	116.3	58.4	
60- 75	15					82.7	83.7	78.9	80.7	84.3	88.6	97.4	109.6	110.0	100.4	91.8	87.6	44.3	
75- 95	20					66.6	67.0	63.9	64.2	66.4	69.4	74.9	81.8	82.3	75.9	70.1	67.0	34.0	
95- 115	20					59.2	57.7	53.4	52.3	53.0	55.3	58.4	62.1	62.4	58.1	54.2	51.9	26.4	
115- 125	10					54.2	52.6	47.3	45.9	46.1	47.2	49.7	52.2	52.3	48.9	45.8	43.9	22.5	
125- 150	25					44.1	42.8	40.5	39.7	39.4	40.2	41.9	43.7	43.5	41.0	38.5	36.9	19.0	
150- 175	25					34.9	34.0	32.9	32.6	32.7	32.8	34.0	35.0	34.7	32.8	30.6	29.4	15.3	
175- 200	25					28.6	27.8	27.6	27.5	27.3	27.8	28.3	28.5	28.3	26.7	25.0	24.3	12.7	
200- 225	25					24.3	23.5	23.0	23.3	23.4	23.4	23.7	24.0	23.7	22.4	20.8	20.3	10.7	

Table A5.3 (continuation)

Equivalent dose rate in the ID access scenario for T= 2 y, t= 100 d – TRT C, LAr EndCap removed

R/Z, cm	dR\dZ	280	280- 290	290- 315	315- 340	340	340- 350	350- 365	365- 380	380- 405	405- 430	430- 480	480- 530	530- 580	580- 630	630- 660	660- 670	670	
		0	10	25	25	0	10	15	15	25	25	50	50	50	50	30	10	0	
0- 5	5																		
5- 10	5					114.7	124.6	259.0	936.7	524.1	348.2	478.6	793.1	700.3	569.8	509.3	482.2	239.6	
10- 20	10					102.1	105.8	158.9	289.1	244.4	186.2	235.7	352.7	323.9	268.5	239.5	226.8	113.0	
20- 30	10					82.5	84.7	105.0	137.4	135.5	119.8	142.9	193.9	184.4	156.3	139.5	132.0	66.0	
30- 45	15					70.9	72.2	73.9	82.9	85.4	83.5	95.7	119.2	116.6	101.0	90.5	85.8	43.0	
45- 60	15					61.6	62.3	55.7	57.4	59.2	60.6	67.8	79.0	78.3	69.4	62.5	59.5	30.0	
60- 75	15					48.2	48.7	44.6	44.6	45.8	47.5	51.8	57.8	57.7	51.9	47.1	44.9	22.8	
75- 95	20					39.3	39.1	36.5	36.1	36.3	37.7	40.1	43.3	43.2	39.4	35.9	34.5	17.6	
95- 115	20					35.0	33.8	30.8	29.6	29.4	29.9	31.5	33.1	33.0	30.2	27.9	26.8	13.7	
115- 125	10					31.9	30.8	27.0	25.9	25.7	25.8	26.9	27.8	27.6	25.5	23.5	22.7	11.8	
125- 150	25					26.1	25.0	23.5	22.4	22.0	22.3	22.8	23.3	23.1	21.4	19.8	19.2	10.0	
150- 175	25					20.6	20.1	19.0	18.4	18.1	18.1	18.6	18.7	18.3	17.0	15.8	15.4	8.2	
175- 200	25					16.6	16.1	15.8	15.7	15.4	15.5	15.7	15.4	15.1	13.9	13.1	12.6	6.7	
200- 225	25					14.2	13.8	13.4	13.2	13.3	13.0	13.0	13.0	12.6	11.6	11.0	10.6	5.6	

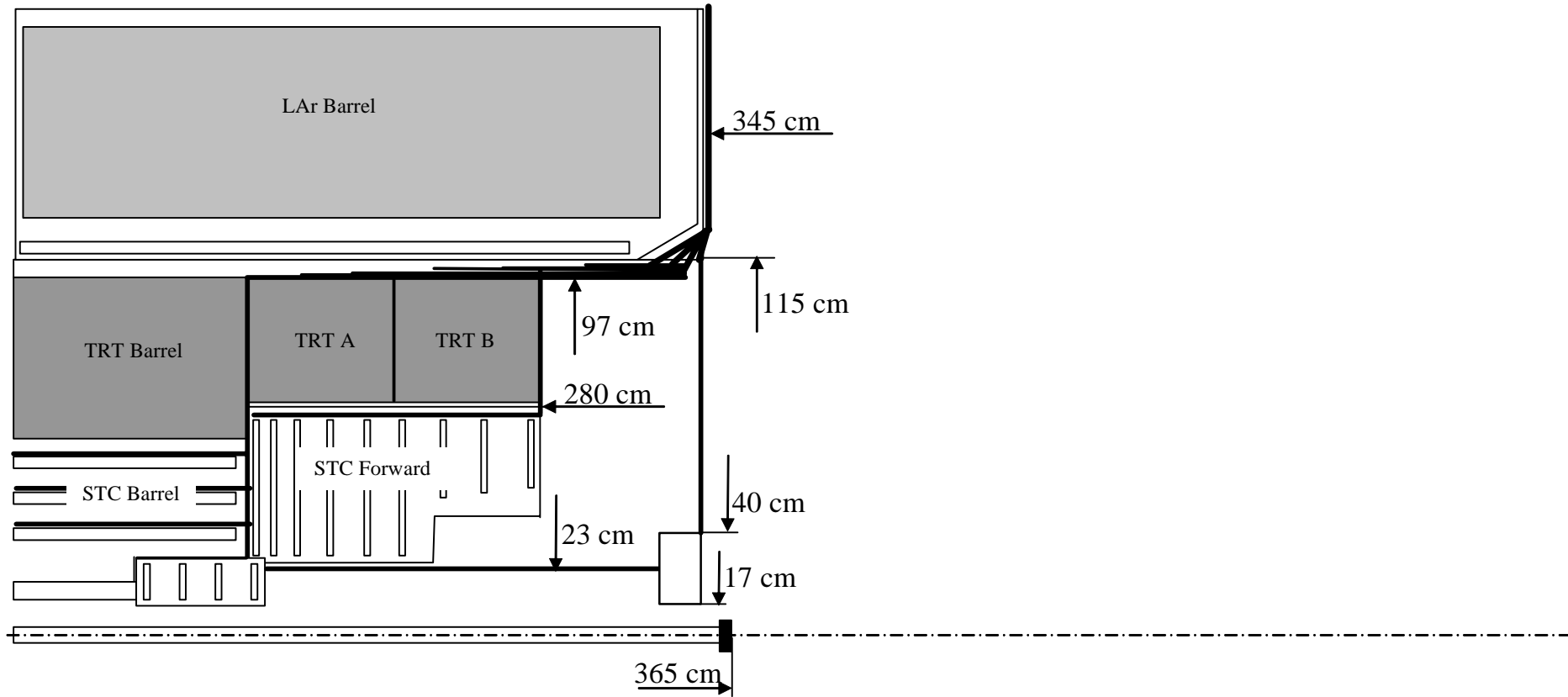

Fig. A5.4. Detector opening layout to calculations of access dose rate – TRT C, Lar EC, and VA removed.

Table A5.4

Equivalent dose rate in the ID access scenario for T= 2 y, t= 1d – TRT C, Lar EC, and VA removed

R/Z, cm	dR\dZ	280	280- 290	290- 315	315- 340	340	340- 350	350- 365	365- 380	380- 405	405- 430	430- 480	480- 530	530- 580	580- 630	630- 660	660- 670	670
		0	10	25	25	0	10	15	15	25	25	50	50	50	50	30	10	0
0- 5	5								193.8	89.5	62.2	46.4	31.3	21.6	13.0	8.1	7.4	7.3
5- 10	5					278.3	247.4	223.4	152.6	88.8	62.3	46.3	31.2	21.6	13.0	8.1	7.4	7.3
10- 20	10					246.2	214.6	161.9	123.9	87.1	62.0	46.0	31.0	21.8	12.9	8.1	7.4	7.3
20- 30	10					201.3	183.5	141.5	111.5	84.3	62.0	45.1	30.7	21.9	12.9	8.1	7.4	7.3
30- 45	15					197.8	185.3	131.7	103.8	80.8	61.7	43.9	30.5	22.3	12.7	8.0	7.3	7.3
45- 60	15					194.3	186.2	123.9	97.5	77.1	60.3	42.6	30.1	22.1	12.6	8.0	7.3	7.3
60- 75	15					159.9	154.7	114.1	91.2	73.2	57.5	41.5	29.4	21.5	12.6	7.6	7.3	7.3
75- 95	20					138.5	134.0	104.3	85.0	68.4	54.0	40.1	27.9	21.1	12.3	7.6	7.3	6.9
95- 115	20					147.2	134.8	99.0	78.4	62.6	50.1	37.6	26.7	20.2	12.2	7.5	6.9	6.8
115- 125	10					142.9	131.1	92.2	72.6	58.3	46.5	35.7	25.8	19.7	12.0	7.5	6.8	6.8
125- 150	25					104.9	97.1	76.9	64.0	52.3	42.7	33.5	24.4	18.8	11.5	7.5	6.7	6.5
150- 175	25					74.9	70.0	58.8	51.2	43.7	36.8	29.6	22.4	17.7	10.8	7.1	6.5	6.5
175- 200	25					54.3	51.5	45.5	41.0	36.5	31.8	26.4	20.8	16.3	9.9	6.7	6.2	6.2
200- 225	25					41.0	38.8	35.5	33.4	29.7	26.4	22.7	18.2	15.1	9.4	6.5	6.0	6.0

Table A5.4 (continuation)

Equivalent dose rate in the ID access scenario for T= 2 y, t= 5 d – TRT C, Lar EC, and VA removed

R/Z, cm	dR\dZ	280	280- 290	290- 315	315- 340	340	340- 350	350- 365	365- 380	380- 405	405- 430	430- 480	480- 530	530- 580	580- 630	630- 660	660- 670	670
		0	10	25	25	0	10	15	15	25	25	50	50	50	50	30	10	0
0- 5	5								65.4	30.2	19.8	15.1	9.9	6.6	4.3	2.5	2.5	2.5
5- 10	5					119.8	100.8	78.6	51.8	29.7	19.9	15.1	9.9	6.6	4.4	2.5	2.5	2.5
10- 20	10					98.8	84.2	57.3	42.0	28.8	19.9	15.1	9.9	6.8	4.4	2.5	2.5	2.5
20- 30	10					75.6	67.6	49.3	37.8	27.9	20.0	14.6	9.9	7.0	4.4	2.5	2.5	2.4
30- 45	15					73.2	68.0	45.7	34.9	26.4	20.0	14.1	9.9	7.2	4.3	2.5	2.5	2.4
45- 60	15					71.3	68.4	42.3	32.2	24.9	19.4	13.6	9.8	7.2	4.3	2.5	2.4	2.4
60- 75	15					55.1	53.5	37.8	29.6	23.6	18.4	13.3	9.5	7.1	4.1	2.5	2.4	2.4
75- 95	20					45.2	43.5	33.5	27.2	21.8	17.5	13.2	9.0	7.1	4.0	2.5	2.4	2.4
95- 115	20					45.1	41.7	31.0	24.5	20.0	16.4	12.2	8.7	6.9	3.9	2.5	2.4	2.4
115- 125	10					43.1	39.9	28.7	22.9	18.8	15.4	11.9	8.4	6.6	3.9	2.5	2.4	2.3
125- 150	25					33.3	30.7	24.9	20.6	17.1	14.1	11.3	8.2	6.2	3.8	2.4	2.2	2.2
150- 175	25					25.7	23.6	20.2	17.4	14.8	12.3	10.0	7.7	5.9	3.6	2.4	2.2	2.1
175- 200	25					19.8	18.3	16.7	14.9	13.0	11.3	9.3	7.0	5.4	3.4	2.3	2.0	2.0
200- 225	25					16.0	14.6	13.4	12.4	10.8	9.4	7.9	6.4	5.1	3.1	2.2	1.9	1.9

Table A5.4 (continuation)
 Equivalent dose rate in the ID access scenario for T= 2 y, t= 15 d – TRT C, Lar EC, and VA removed

R/Z, cm	dR\dZ	280	280- 290	290- 315	315- 340	340	340- 350	350- 365	365- 380	380- 405	405- 430	430- 480	480- 530	530- 580	580- 630	630- 660	660- 670	670
		0	10	25	25	0	10	15	15	25	25	50	50	50	50	30	10	0
0- 5	5								55.1	23.6	15.7	11.7	7.7	5.0	3.2	2.0	1.8	1.8
5- 10	5					93.1	79.7	65.2	42.7	23.4	15.8	11.7	7.7	5.0	3.2	2.0	1.8	1.8
10- 20	10					78.0	66.5	46.1	33.8	22.7	15.7	11.7	7.7	5.2	3.2	2.0	1.8	1.8
20- 30	10					59.8	53.7	39.3	29.7	21.8	15.7	11.5	7.7	5.3	3.1	2.0	1.8	1.8
30- 45	15					58.5	54.7	36.2	27.2	20.6	15.4	11.0	7.7	5.4	3.1	1.9	1.8	1.8
45- 60	15					57.4	55.2	33.7	24.9	19.6	15.1	10.5	7.5	5.5	3.2	1.9	1.8	1.8
60- 75	15					44.0	42.4	29.6	23.1	18.4	14.3	10.3	7.3	5.5	3.2	1.9	1.8	1.8
75- 95	20					35.6	34.6	26.0	21.2	17.0	13.6	10.1	6.9	5.4	3.2	1.9	1.8	1.8
95- 115	20					35.2	32.5	24.0	19.3	15.5	12.7	9.5	6.7	5.3	3.0	1.9	1.8	1.8
115- 125	10					33.5	31.0	22.3	17.6	14.4	11.7	9.1	6.6	5.1	3.0	1.8	1.8	1.8
125- 150	25					25.7	23.9	19.1	15.9	12.9	10.8	8.6	6.4	4.9	2.9	1.8	1.7	1.6
150- 175	25					19.3	17.7	15.2	13.2	11.2	9.6	7.6	5.8	4.5	2.7	1.8	1.5	1.5
175- 200	25					15.1	13.6	12.6	11.4	9.9	8.5	7.1	5.4	4.2	2.5	1.8	1.5	1.5
200- 225	25					12.1	11.1	10.4	9.5	8.3	7.2	6.1	4.8	4.0	2.4	1.5	1.4	1.4

Table A5.4 (continuation)
 Equivalent dose rate in the ID access scenario for T= 2 y, t= 30 d – TRT C, Lar EC, and VA removed

R/Z, cm	dR\dZ	280	280-290	290-315	315-340	340	340-350	350-365	365-380	380-405	405-430	430-480	480-530	530-580	580-630	630-660	660-670	670
		0	10	25	25	0	10	15	15	25	25	50	50	50	50	30	10	0
0- 5	5								49.7	20.0	13.4	9.6	6.5	4.4	2.6	1.8	1.7	1.6
5- 10	5					77.5	67.1	58.6	37.6	19.8	13.4	9.6	6.4	4.4	2.6	1.8	1.7	1.6
10- 20	10					65.5	55.7	39.9	29.0	19.3	13.3	9.6	6.4	4.4	2.6	1.8	1.7	1.6
20- 30	10					50.4	45.2	33.6	25.2	18.4	13.2	9.4	6.4	4.6	2.6	1.8	1.7	1.6
30- 45	15					49.3	46.1	30.7	23.0	17.4	13.1	9.1	6.4	4.6	2.5	1.8	1.7	1.5
45- 60	15					49.1	47.0	28.2	21.2	16.4	12.5	8.8	6.3	4.6	2.6	1.8	1.6	1.5
60- 75	15					37.2	36.2	24.9	19.4	15.3	12.0	8.7	5.9	4.5	2.6	1.7	1.5	1.5
75- 95	20					30.0	29.1	21.9	17.6	14.3	11.3	8.3	5.8	4.5	2.5	1.7	1.5	1.4
95- 115	20					29.4	27.1	20.1	16.0	12.8	10.7	7.8	5.5	4.1	2.3	1.7	1.3	1.3
115- 125	10					28.0	25.9	18.6	14.8	12.1	9.6	7.4	5.4	4.0	2.3	1.7	1.3	1.3
125- 150	25					21.4	19.7	15.8	13.3	10.7	8.7	6.9	5.2	3.9	2.4	1.7	1.3	1.3
150- 175	25					15.9	14.7	12.5	11.0	9.4	7.7	6.3	4.9	3.8	2.4	1.5	1.2	1.2
175- 200	25					12.4	11.3	10.3	9.4	8.1	7.1	5.8	4.4	3.5	2.2	1.3	1.2	1.2
200- 225	25					10.2	9.3	8.2	7.8	7.1	6.0	5.0	4.0	3.2	2.1	1.2	1.1	1.1

Table A5.4 (continuation)
 Equivalent dose rate in the ID access scenario for T= 2 y, t= 100 d– TRT C, Lar EC, and VA removed

R/Z, cm	dR\dZ	280	280- 290	290- 315	315- 340	340	340- 350	350- 365	365- 380	380- 405	405- 430	430- 480	480- 530	530- 580	580- 630	630- 660	660- 670	670
		0	10	25	25	0	10	15	15	25	25	50	50	50	50	30	10	0
0- 5	5								39.6	13.7	9.1	6.5	4.2	3.0	1.7	1.0	0.9	0.9
5- 10	5					50.7	45.7	45.1	28.5	13.6	9.0	6.5	4.2	3.0	1.7	1.0	0.9	0.9
10- 20	10					44.7	37.8	28.5	20.8	13.2	9.1	6.5	4.2	3.1	1.7	1.0	0.9	0.9
20- 30	10					34.5	30.4	23.1	17.6	12.6	9.0	6.3	4.2	3.1	1.7	1.0	0.9	0.9
30- 45	15					33.2	31.2	20.8	15.7	11.7	8.8	6.3	4.1	3.1	1.7	1.0	0.9	0.9
45- 60	15					32.5	31.4	19.1	14.4	10.8	8.3	6.2	4.0	3.0	1.6	0.9	0.9	0.9
60- 75	15					24.9	24.3	16.8	13.1	10.3	8.1	5.9	4.0	3.1	1.6	0.9	0.9	0.9
75- 95	20					20.5	19.6	14.9	12.1	9.4	7.7	5.7	3.9	3.0	1.6	0.9	0.9	0.9
95- 115	20					19.6	18.0	13.7	10.9	8.7	6.9	5.3	3.8	2.9	1.5	0.9	0.9	0.9
115- 125	10					18.5	17.1	12.2	9.9	8.1	6.4	5.1	3.6	2.7	1.5	0.9	0.9	0.9
125- 150	25					14.4	13.1	10.8	8.8	7.2	6.1	4.7	3.4	2.6	1.5	0.9	0.9	0.9
150- 175	25					10.8	10.2	8.5	7.3	6.2	5.2	4.4	3.2	2.4	1.4	0.9	0.9	0.9
175- 200	25					8.2	7.6	7.0	6.3	5.5	4.8	4.1	3.0	2.3	1.2	0.9	0.8	0.8
200- 225	25					6.9	6.4	5.8	5.3	4.9	4.1	3.4	2.7	2.1	1.2	0.9	0.7	0.7

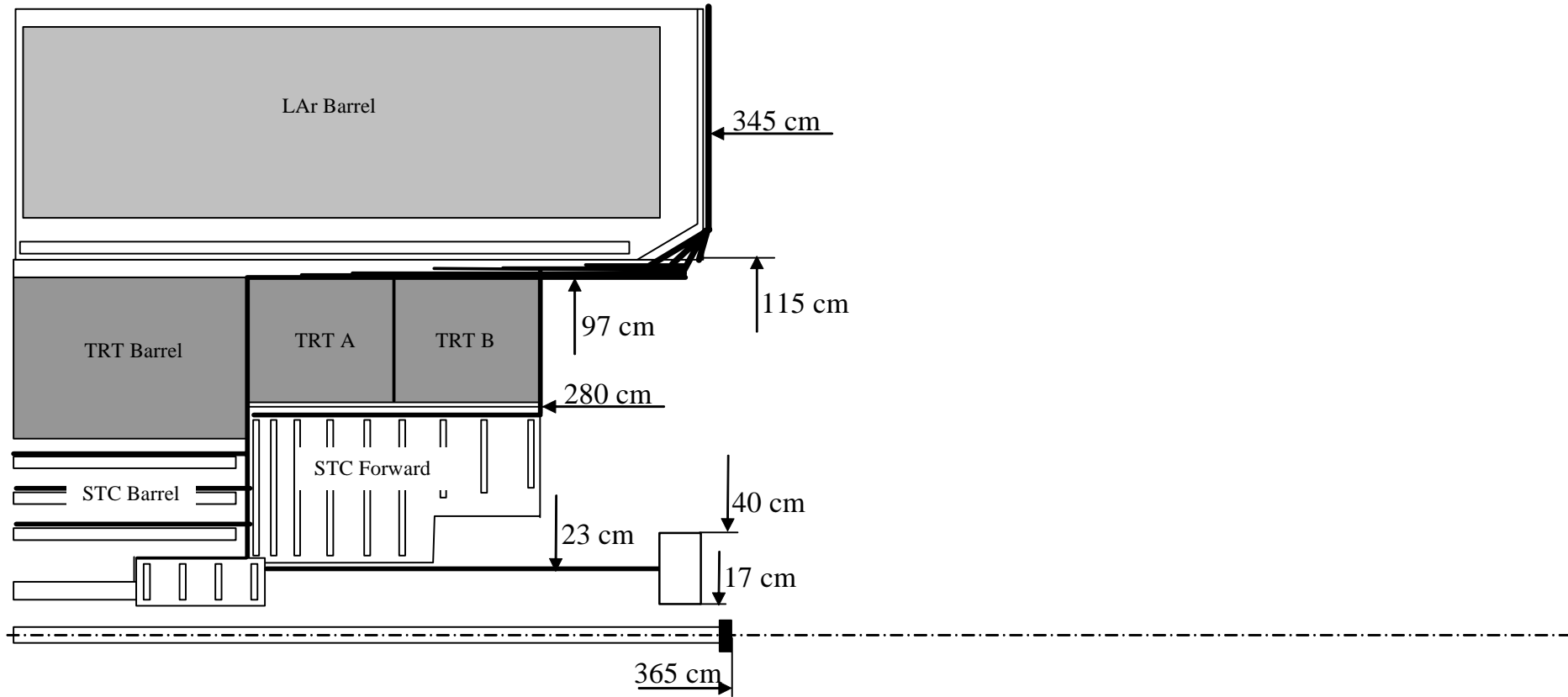

Fig. A5.5 Detector opening layout to calculations of access dose rate – TRT C, LAr EC, VA, and Pixel Type 2 services removed.

Table A5.5

Equivalent dose rate in the ID access scenario for T= 2 y, t= 1d – TRT C, LAr EC, VA, and Pixel Type 2 services removed

R/Z, cm	dR\dZ	280	280- 290	290- 315	315- 340	340	340- 350	350- 365	365- 380	380- 405	405- 430	430- 480	480- 530	530- 580	580- 630	630- 660	660- 670	670
		0	10	25	25	0	10	15	15	25	25	50	50	50	50	30	10	0
0- 5	5								179.1	78.6	54.7	41.7	28.6	19.8	11.8	7.1	6.5	6.4
5- 10	5					259.3	228.4	205.7	137.9	77.9	54.8	41.6	28.5	19.8	11.8	7.1	6.5	6.4
10- 20	10					225.9	194.3	143.3	108.8	76.1	54.5	41.4	28.3	20.0	11.7	7.1	6.5	6.4
20- 30	10	165.1	166.2	213.0		177.1	159.4	120.7	95.7	73.2	54.5	40.5	28.0	20.1	11.7	7.1	6.5	6.4
30- 45	15	159.9	159.0	187.7		142.9	131.5	105.6	87.2	69.8	54.4	39.4	27.8	20.5	11.5	7.0	6.4	6.4
45- 60	15	167.0	158.5	149.1	137.2	116.1	110.1	95.2	80.8	66.4	53.3	38.2	27.6	20.4	11.4	7.0	6.4	6.4
60- 75	15	176.2	160.5	136.6	117.1	104.9	100.9	89.4	76.0	63.3	51.0	37.3	26.9	19.9	11.4	6.7	6.4	6.4
75- 95	20	169.7	157.8	134.7	113.7	101.7	98.0	85.4	72.4	59.7	48.0	36.3	25.6	19.5	11.1	6.7	6.4	6.1
95- 115	20					123.8	111.7	85.3	68.5	55.3	44.9	34.1	24.4	18.6	11.1	6.6	6.1	6.0
115- 125	10					124.6	113.1	81.3	64.3	52.0	41.8	32.5	23.7	18.2	10.9	6.6	6.0	6.0
125- 150	25					91.1	83.5	68.3	57.2	47.0	38.6	30.6	22.5	17.4	10.5	6.6	6.0	5.8
150- 175	25					65.4	60.6	52.5	46.1	39.6	33.4	27.1	20.7	16.4	9.8	6.3	5.8	5.8
175- 200	25					47.9	45.2	41.0	37.2	33.2	29.1	24.2	19.2	15.1	9.0	6.0	5.5	5.5
200- 225	25					36.7	34.5	32.2	30.4	27.1	24.1	20.9	16.8	14.0	8.5	5.8	5.3	5.3

Table A5.5 (continuation)

Equivalent dose rate in the ID access scenario for T= 2 y, t= 5 d – TRT C, LAr EC, VA, and Pixel Type 2 services removed

R/Z, cm	dR\dZ	280	280- 290	290- 315	315- 340	340	340- 350	350- 365	365- 380	380- 405	405- 430	430- 480	480- 530	530- 580	580- 630	630- 660	660- 670	670
		0	10	25	25	0	10	15	15	25	25	50	50	50	50	30	10	0
0- 5	5					98.4	100.1	142.0	59.3	25.7	16.8	13.2	8.9	5.9	3.8	2.1	2.1	2.1
5- 10	5					111.7	92.7	71.1	45.6	25.2	16.9	13.2	8.9	5.9	3.9	2.1	2.1	2.1
10- 20	10					90.1	75.5	49.4	35.7	24.3	16.9	13.2	8.9	6.1	3.9	2.1	2.1	2.1
20- 30	10	52.7	53.9	77.9		65.2	57.3	40.5	31.2	23.3	17.0	12.8	8.9	6.3	3.9	2.1	2.1	2.1
30- 45	15	49.1	49.6	63.1		48.6	44.0	34.5	28.0	21.8	17.1	12.3	8.9	6.6	3.8	2.1	2.1	2.1
45- 60	15	50.0	47.7	46.0	43.9	37.0	35.0	30.1	25.3	20.6	16.6	11.9	8.8	6.6	3.8	2.1	2.1	2.1
60- 75	15	51.3	46.5	40.0	35.7	32.4	31.3	27.6	23.4	19.6	15.8	11.7	8.5	6.5	3.7	2.1	2.1	2.1
75- 95	20	47.2	44.0	38.2	33.5	31.0	29.6	26.1	22.2	18.4	15.2	11.7	8.1	6.5	3.6	2.1	2.1	2.1
95- 115	20					36.5	33.2	25.8	20.7	17.2	14.4	10.9	7.8	6.3	3.5	2.1	2.1	2.1
115- 125	10					36.8	33.6	24.7	19.8	16.4	13.6	10.6	7.6	6.1	3.5	2.1	2.1	2.0
125- 150	25					28.7	26.2	21.9	18.2	15.1	12.5	10.2	7.4	5.7	3.4	2.1	1.9	1.9
150- 175	25					22.7	20.6	18.1	15.6	13.3	11.1	9.1	7.0	5.4	3.2	2.1	1.9	1.8
175- 200	25					17.8	16.3	15.1	13.5	11.8	10.3	8.5	6.5	5.0	3.0	2.0	1.7	1.7
200- 225	25					14.6	13.2	12.3	11.4	9.9	8.6	7.2	5.9	4.7	2.8	1.9	1.6	1.6

Table A5.5 (continuation)

Equivalent dose rate in the ID access scenario for T= 2 y, t= 15 d – TRT C, LAr EC, VA, and Pixel Type 2 services removed

R/Z, cm	dR\dZ	280	280- 290	290- 315	315- 340	340	340- 350	350- 365	365- 380	380- 405	405- 430	430- 480	480- 530	530- 580	580- 630	630- 660	660- 670	670
		0	10	25	25	0	10	15	15	25	25	50	50	50	50	30	10	0
0- 5	5					78.0	81.6	123.6	50.0	19.8	13.1	10.1	6.8	4.5	2.8	1.7	1.5	1.5
5- 10	5					86.4	73.0	59.0	37.5	19.6	13.2	10.1	6.8	4.5	2.8	1.7	1.5	1.5
10- 20	10					70.7	59.3	39.5	28.5	18.9	13.1	10.1	6.8	4.7	2.8	1.7	1.5	1.5
20- 30	10	40.9	41.6	60.3		51.1	45.0	31.9	24.2	18.0	13.1	9.9	6.8	4.8	2.7	1.7	1.5	1.5
30- 45	15	38.4	38.4	48.9		38.0	34.6	26.8	21.3	16.8	13.0	9.6	6.8	4.9	2.7	1.6	1.5	1.5
45- 60	15	39.0	37.3	35.6	34.2	28.8	27.3	23.4	19.1	15.9	12.8	9.1	6.7	5.0	2.8	1.6	1.5	1.5
60- 75	15	39.6	36.0	31.1	27.6	24.9	23.8	21.1	17.9	15.1	12.1	9.0	6.5	5.0	2.8	1.6	1.5	1.5
75- 95	20	36.4	34.2	29.4	25.8	23.6	22.8	19.8	17.0	14.1	11.6	8.8	6.1	4.9	2.8	1.6	1.5	1.5
95- 115	20					27.9	25.3	19.7	16.1	13.1	11.0	8.3	6.0	4.8	2.6	1.6	1.5	1.5
115- 125	10					28.1	25.6	18.9	15.0	12.4	10.2	8.0	5.9	4.6	2.6	1.5	1.5	1.5
125- 150	25					21.7	20.0	16.5	13.8	11.3	9.5	7.7	5.7	4.5	2.6	1.5	1.4	1.3
150- 175	25					16.7	15.2	13.4	11.6	9.9	8.5	6.8	5.3	4.1	2.4	1.5	1.2	1.2
175- 200	25					13.3	12.0	11.3	10.2	8.9	7.7	6.4	4.9	3.8	2.2	1.5	1.2	1.2
200- 225	25					11.0	10.0	9.5	8.6	7.5	6.5	5.5	4.4	3.6	2.1	1.2	1.1	1.1

Table A5.5 (continuation)

Equivalent dose rate in the ID access scenario for T= 2 y, t= 30 d – TRT C, LAr EC, VA, and Pixel Type 2 services removed

R/Z, cm	dR\dZ	280	280- 290	290- 315	315- 340	340	340- 350	350- 365	365- 380	380- 405	405- 430	430- 480	480- 530	530- 580	580- 630	630- 660	660- 670	670
		0	10	25	25	0	10	15	15	25	25	50	50	50	50	30	10	0
0- 5	5					65.8	70.6	115.6	45.2	16.7	11.2	8.3	5.7	3.9	2.2	1.5	1.4	1.3
5- 10	5					71.6	61.2	53.1	33.1	16.5	11.2	8.3	5.6	3.9	2.2	1.5	1.4	1.3
10- 20	10					59.3	49.5	34.2	24.4	16.0	11.1	8.3	5.6	3.9	2.2	1.5	1.4	1.3
20- 30	10	34.1	35.0	49.7		42.8	37.6	27.1	20.4	15.1	11.0	8.1	5.6	4.1	2.2	1.5	1.4	1.3
30- 45	15	31.9	32.0	40.5		31.7	28.8	22.6	18.0	14.1	11.0	7.8	5.6	4.1	2.2	1.5	1.4	1.2
45- 60	15	32.5	30.9	29.8	28.9	24.3	22.9	19.3	16.2	13.2	10.5	7.6	5.6	4.1	2.3	1.5	1.3	1.2
60- 75	15	32.8	29.7	25.9	23.0	20.6	20.0	17.5	14.8	12.4	10.1	7.5	5.2	4.1	2.3	1.4	1.2	1.2
75- 95	20	30.0	28.3	25.0	21.5	19.5	18.8	16.4	14.0	11.8	9.6	7.2	5.1	4.1	2.2	1.4	1.2	1.1
95- 115	20					23.0	20.8	16.3	13.2	10.7	9.2	6.8	4.8	3.7	2.0	1.4	1.0	1.0
115- 125	10					23.3	21.2	15.6	12.5	10.3	8.3	6.4	4.8	3.6	2.0	1.4	1.0	1.0
125- 150	25					17.9	16.2	13.5	11.4	9.3	7.6	6.1	4.6	3.5	2.1	1.4	1.0	1.0
150- 175	25					13.6	12.4	10.9	9.7	8.3	6.8	5.6	4.4	3.4	2.1	1.2	1.0	1.0
175- 200	25					10.9	9.8	9.2	8.4	7.2	6.4	5.2	4.0	3.2	1.9	1.0	1.0	1.0
200- 225	25					9.2	8.3	7.4	7.0	6.4	5.4	4.5	3.6	2.9	1.8	1.0	0.9	0.9

Table A5.5 (continuation)

Equivalent dose rate in the ID access scenario for T= 2 y, t= 100 d– TRT C, LAr EC, VA, and Pixel Type 2 services removed

R/Z, cm	dR\dZ	280	280- 290	290- 315	315- 340	340	340- 350	350- 365	365- 380	380- 405	405- 430	430- 480	480- 530	530- 580	580- 630	630- 660	660- 670	670
		0	10	25	25	0	10	15	15	25	25	50	50	50	50	30	10	0
0- 5	5					44.9	51.5	98.7	36.6	11.5	7.6	5.6	3.7	2.7	1.4	0.8	0.7	0.7
5- 10	5					46.8	41.8	41.5	25.5	11.3	7.5	5.6	3.7	2.7	1.4	0.8	0.7	0.7
10- 20	10					40.6	33.7	24.7	17.7	10.9	7.6	5.6	3.7	2.8	1.4	0.8	0.7	0.7
20- 30	10	23.3	23.8	31.1		29.5	25.5	18.8	14.4	10.3	7.5	5.4	3.7	2.8	1.4	0.8	0.7	0.7
30- 45	15	21.3	21.4	25.5		21.6	19.8	15.5	12.3	9.5	7.3	5.4	3.6	2.8	1.4	0.8	0.7	0.7
45- 60	15	21.3	20.3	19.6	19.2	16.1	15.4	13.2	11.0	8.6	7.0	5.3	3.5	2.7	1.4	0.7	0.7	0.7
60- 75	15	21.5	19.7	17.2	15.6	13.8	13.4	11.8	10.1	8.4	6.8	5.1	3.5	2.8	1.4	0.7	0.7	0.7
75- 95	20	20.0	18.7	16.6	14.4	13.3	12.6	11.2	9.6	7.7	6.5	4.9	3.4	2.7	1.4	0.7	0.7	0.7
95- 115	20					15.2	13.7	11.1	9.0	7.3	5.9	4.7	3.3	2.6	1.3	0.7	0.7	0.7
115- 125	10					15.2	13.9	10.2	8.3	6.9	5.5	4.5	3.2	2.4	1.3	0.7	0.7	0.7
125- 150	25					12.0	10.7	9.2	7.5	6.2	5.3	4.1	3.1	2.3	1.3	0.7	0.7	0.7
150- 175	25					9.2	8.6	7.4	6.4	5.4	4.6	3.9	2.9	2.1	1.2	0.7	0.7	0.7
175- 200	25					7.2	6.6	6.2	5.6	4.9	4.3	3.6	2.7	2.1	1.0	0.7	0.7	0.7
200- 225	25					6.1	5.6	5.2	4.8	4.4	3.6	3.1	2.4	1.9	1.0	0.7	0.6	0.6

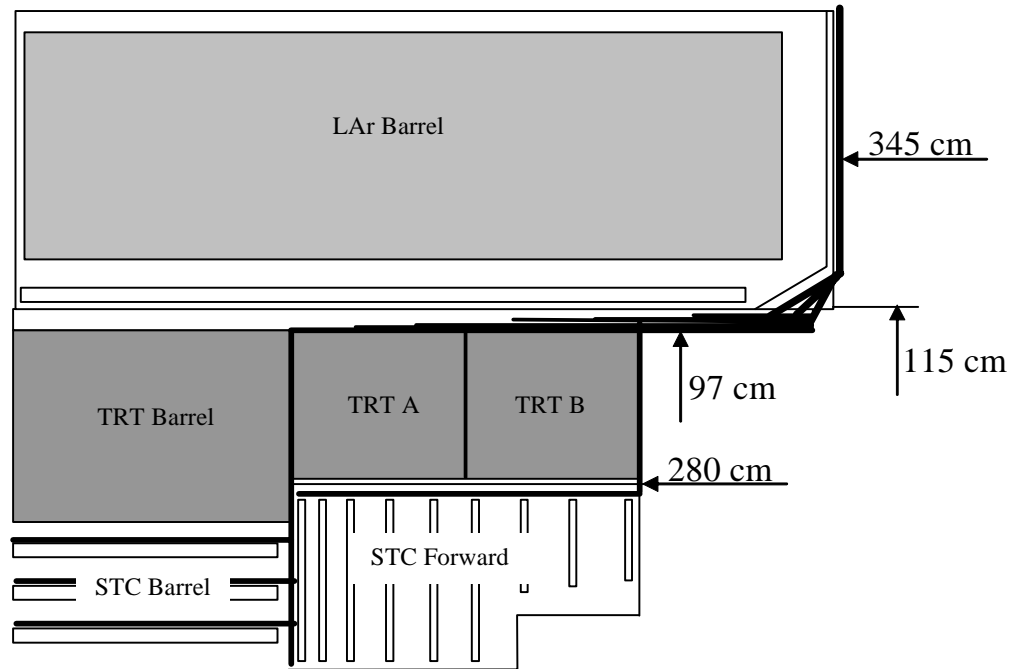

Fig. A5.6. Detector opening layout to calculations of access dose rate – TRT C, LAr EC, VA, Pixel Type 2 services, Pixel Detector, and VI removed.

Table A5.6

Equivalent dose rate in the ID access scenario for T= 2 y, t= 1d – TRT C, LAr EC, VA, Pixel Type 2 services, Pixel Det, and VI removed

R/Z, cm	dR\dZ	280	280- 290	290- 315	315- 340	340	340- 350	350- 365	365- 380	380- 405	405- 430	430- 480	480- 530	530- 580	580- 630	630- 660	660- 670	670
		0	10	25	25	0	10	15	15	25	25	50	50	50	50	30	10	0
0- 5	5	114.6	111.4	98.9	86.4	78.1	74.3	68.5	63.0	54.2	42.9	35.4	25.0	17.4	10.2	5.7	5.3	5.2
5- 10	5	114.8	111.6	99.1	86.5	78.1	74.5	68.6	62.8	54.2	43.0	35.4	24.9	17.4	10.2	5.7	5.3	5.2
10- 20	10	115.9	112.7	99.6	86.8	78.6	75.1	68.7	62.6	54.2	43.1	35.2	24.7	17.7	10.1	5.7	5.3	5.2
20- 30	10	119.8	115.4	101.0	87.2	78.9	76.0	69.3	62.4	54.0	43.7	34.4	24.5	17.9	10.1	5.7	5.3	5.2
30- 45	15	126.3	121.0	103.6	88.3	80.4	76.8	69.1	61.9	53.6	44.4	33.5	24.4	18.3	9.9	5.7	5.2	5.2
45- 60	15	142.0	131.0	107.9	89.9	80.9	77.5	69.9	61.7	53.0	44.3	32.7	24.3	18.2	9.8	5.7	5.2	5.2
60- 75	15	157.6	140.8	112.7	91.9	82.5	79.6	71.3	61.4	52.2	43.1	32.3	23.8	17.7	9.8	5.5	5.2	5.2
75- 95	20	156.3	143.8	119.3	98.1	87.0	83.8	72.7	61.4	50.9	41.3	31.7	22.6	17.4	9.6	5.5	5.2	5.0
95- 115	20					113.8	101.8	76.1	60.2	48.3	39.3	30.0	21.7	16.6	9.6	5.4	5.0	4.9
115- 125	10					116.7	105.3	73.9	57.6	46.1	36.9	28.7	21.1	16.2	9.4	5.4	4.9	4.9
125- 150	25					84.8	77.3	62.3	51.6	42.0	34.3	27.2	20.0	15.6	9.1	5.4	4.9	4.7
150- 175	25					60.6	55.8	48.0	41.7	35.6	29.8	24.2	18.5	14.8	8.4	5.2	4.7	4.7
175- 200	25					44.1	41.4	37.4	33.7	29.9	26.1	21.7	17.2	13.5	7.8	4.9	4.5	4.5
200- 225	25					33.5	31.4	29.1	27.4	24.4	21.5	18.7	15.1	12.5	7.3	4.7	4.3	4.3

Table A5.6 (continuation)

Equivalent dose rate in the ID access scenario for T= 2 y, t= 5 d – TRT C, LAr EC, VA, Pixel Type 2 services, Pixel Det, and VI removed

R/Z, cm	dR\dZ	280	280- 290	290- 315	315- 340	340	340- 350	350- 365	365- 380	380- 405	405- 430	430- 480	480- 530	530- 580	580- 630	630- 660	660- 670	670
		0	10	25	25	0	10	15	15	25	25	50	50	50	50	30	10	0
0- 5	5	31.5	30.8	26.1	23.4	21.9	20.5	18.2	17.1	15.7	11.9	10.5	7.4	4.9	3.0	1.6	1.6	1.6
5- 10	5	31.5	30.9	26.1	23.5	21.9	20.6	18.2	17.1	15.5	12.0	10.5	7.4	4.9	3.1	1.6	1.6	1.6
10- 20	10	32.0	31.2	26.3	23.5	22.0	20.6	18.5	17.2	15.3	12.1	10.5	7.4	5.1	3.1	1.6	1.6	1.6
20- 30	10	33.5	32.1	26.7	23.7	22.2	20.7	18.6	17.3	15.3	12.4	10.2	7.4	5.3	3.1	1.6	1.6	1.6
30- 45	15	34.7	33.3	27.6	23.9	22.2	20.8	19.0	17.3	14.9	12.8	9.8	7.5	5.6	3.0	1.6	1.6	1.6
45- 60	15	39.2	35.9	28.8	24.6	22.2	21.4	19.4	17.2	14.8	12.9	9.6	7.4	5.6	3.0	1.6	1.6	1.6
60- 75	15	43.3	38.0	29.9	25.1	22.9	22.3	19.9	17.1	14.9	12.5	9.5	7.2	5.5	3.0	1.6	1.6	1.6
75- 95	20	41.3	38.0	31.6	26.8	24.7	23.5	20.6	17.4	14.7	12.3	9.7	6.8	5.6	3.0	1.6	1.6	1.6
95- 115	20					32.1	29.0	21.9	17.2	14.3	12.0	9.2	6.6	5.4	2.9	1.6	1.6	1.6
115- 125	10					33.4	30.3	21.6	16.9	13.9	11.4	9.0	6.5	5.2	2.9	1.6	1.6	1.6
125- 150	25					26.0	23.5	19.3	15.8	12.9	10.7	8.8	6.3	4.9	2.8	1.6	1.5	1.5
150- 175	25					20.6	18.6	16.1	13.7	11.6	9.6	7.8	6.0	4.6	2.7	1.6	1.5	1.4
175- 200	25					16.1	14.6	13.5	12.0	10.4	9.0	7.4	5.6	4.4	2.5	1.6	1.3	1.3
200- 225	25					13.2	11.8	10.9	10.1	8.7	7.5	6.2	5.1	4.1	2.3	1.5	1.2	1.2

Table A5.6 (continuation)

Equivalent dose rate in the ID access scenario for T= 2 y, t= 15 d – TRT C, LAr EC, VA, Pixel Type 2 services, Pixel Det, and VI removed

R/Z, cm	dR\dZ	280	280- 290	290- 315	315- 340	340	340- 350	350- 365	365- 380	380- 405	405- 430	430- 480	480- 530	530- 580	580- 630	630- 660	660- 670	670
		0	10	25	25	0	10	15	15	25	25	50	50	50	50	30	10	0
0- 5	5	23.5	23.2	19.9	17.7	16.3	15.5	13.8	13.0	11.7	9.1	7.9	5.6	3.7	2.3	1.3	1.1	1.1
5- 10	5	23.6	23.2	19.9	17.7	16.3	15.5	13.8	13.0	11.6	9.2	7.9	5.6	3.7	2.3	1.3	1.1	1.1
10- 20	10	23.9	23.7	20.1	17.9	16.4	15.6	13.9	13.0	11.6	9.2	7.9	5.6	3.9	2.3	1.3	1.1	1.1
20- 30	10	25.2	24.0	20.4	18.2	16.5	15.7	14.1	12.8	11.5	9.4	7.8	5.6	4.0	2.2	1.3	1.1	1.1
30- 45	15	26.7	25.3	21.0	18.2	16.7	15.9	14.2	12.7	11.3	9.6	7.6	5.6	4.1	2.2	1.2	1.1	1.1
45- 60	15	30.4	27.9	21.8	18.5	16.8	16.2	14.7	12.6	11.3	9.7	7.2	5.6	4.2	2.3	1.2	1.1	1.1
60- 75	15	33.2	29.2	23.0	19.1	17.3	16.6	15.0	12.9	11.4	9.4	7.2	5.4	4.2	2.3	1.2	1.1	1.1
75- 95	20	31.7	29.4	24.2	20.5	18.6	17.9	15.4	13.3	11.1	9.3	7.2	5.1	4.1	2.3	1.2	1.1	1.1
95- 115	20					24.5	22.0	16.6	13.3	10.7	9.0	6.9	5.0	4.1	2.1	1.2	1.1	1.1
115- 125	10					25.4	22.9	16.4	12.7	10.3	8.4	6.7	5.0	3.9	2.1	1.1	1.1	1.1
125- 150	25					19.5	17.8	14.4	11.9	9.6	8.0	6.5	4.8	3.8	2.1	1.1	1.0	1.0
150- 175	25					15.0	13.6	11.8	10.1	8.5	7.3	5.8	4.5	3.6	2.0	1.1	0.9	0.9
175- 200	25					11.9	10.7	10.0	9.0	7.7	6.6	5.5	4.2	3.3	1.8	1.1	0.9	0.9
200- 225	25					9.9	8.9	8.4	7.5	6.5	5.6	4.7	3.8	3.1	1.7	0.9	0.8	0.8

Table A5.6 (continuation)

Equivalent dose rate in the ID access scenario for T= 2 y, t= 30 d – TRT C, LAr EC, VA, Pixel Type 2 services, Pixel Det, and VI removed

R/Z, cm	dR\dZ	280	280- 290	290- 315	315- 340	340	340- 350	350- 365	365- 380	380- 405	405- 430	430- 480	480- 530	530- 580	580- 630	630- 660	660- 670	670
		0	10	25	25	0	10	15	15	25	25	50	50	50	50	30	10	0
0- 5	5	19.4	19.0	16.6	14.8	13.4	12.6	11.7	10.7	9.5	7.7	6.4	4.7	3.2	1.8	1.1	1.1	1.0
5- 10	5	19.5	19.1	16.6	14.8	13.5	12.6	11.8	10.6	9.5	7.7	6.4	4.6	3.2	1.8	1.1	1.1	1.0
10- 20	10	19.8	19.2	16.8	14.7	13.4	12.6	11.8	10.6	9.5	7.7	6.4	4.6	3.2	1.8	1.1	1.1	1.0
20- 30	10	20.7	20.0	17.1	14.8	13.4	12.8	11.8	10.5	9.4	7.8	6.3	4.6	3.4	1.8	1.1	1.1	1.0
30- 45	15	22.1	21.0	17.6	15.2	13.6	12.9	11.8	10.6	9.3	8.0	6.1	4.6	3.4	1.8	1.1	1.1	0.9
45- 60	15	25.2	22.9	18.2	15.4	14.0	13.4	12.0	10.6	9.3	7.9	6.0	4.6	3.4	1.9	1.1	1.0	0.9
60- 75	15	27.4	24.1	19.1	15.8	14.2	13.9	12.3	10.5	9.2	7.8	6.0	4.3	3.4	1.9	1.1	0.9	0.9
75- 95	20	26.1	24.3	20.5	17.0	15.3	14.7	12.7	10.8	9.2	7.7	5.8	4.2	3.4	1.8	1.1	0.9	0.8
95- 115	20					20.1	18.0	13.7	10.8	8.7	7.5	5.6	4.0	3.1	1.6	1.1	0.7	0.7
115- 125	10					21.0	18.9	13.4	10.5	8.5	6.9	5.3	4.0	3.0	1.6	1.1	0.7	0.7
125- 150	25					16.1	14.4	11.8	9.8	7.9	6.4	5.1	3.8	3.0	1.7	1.1	0.7	0.7
150- 175	25					12.2	11.0	9.6	8.4	7.1	5.7	4.7	3.7	2.9	1.7	0.9	0.7	0.7
175- 200	25					9.7	8.7	8.1	7.3	6.2	5.5	4.4	3.4	2.8	1.6	0.7	0.7	0.7
200- 225	25					8.2	7.3	6.5	6.1	5.5	4.6	3.8	3.1	2.5	1.5	0.7	0.6	0.6

Table A5.6 (continuation)
 Equivalent dose rate in the ID access scenario for T= 2 y, t= 100 d– TRT C, LAr EC, VA, Pixel Type 2 services, Pixel Det, and VI removed

R/Z, cm	dR\dZ	280	280- 290	290- 315	315- 340	340	340- 350	350- 365	365- 380	380- 405	405- 430	430- 480	480- 530	530- 580	580- 630	630- 660	660- 670	670
		0	10	25	25	0	10	15	15	25	25	50	50	50	50	30	10	0
0- 5	5	13.1	12.6	11.0	9.8	8.9	8.3	7.8	7.2	6.1	5.1	4.3	3.0	2.2	1.1	0.6	0.5	0.5
5- 10	5	13.1	12.6	11.0	9.8	8.9	8.3	7.8	7.2	6.1	5.1	4.3	3.0	2.2	1.1	0.6	0.5	0.5
10- 20	10	13.3	12.9	11.3	9.7	9.1	8.4	7.8	7.1	6.1	5.2	4.3	3.0	2.3	1.1	0.6	0.5	0.5
20- 30	10	14.1	13.6	11.4	9.9	9.2	8.4	7.8	7.2	6.2	5.2	4.2	3.0	2.3	1.1	0.6	0.5	0.5
30- 45	15	14.9	14.2	11.6	9.9	9.1	8.8	7.9	7.1	6.1	5.2	4.2	2.9	2.3	1.1	0.6	0.5	0.5
45- 60	15	16.5	15.1	12.1	10.1	9.1	8.9	8.1	7.1	5.9	5.2	4.2	2.8	2.2	1.1	0.5	0.5	0.5
60- 75	15	17.9	16.0	12.7	10.7	9.4	9.2	8.2	7.2	6.1	5.2	4.0	2.8	2.3	1.1	0.5	0.5	0.5
75- 95	20	17.3	16.0	13.6	11.3	10.4	9.8	8.6	7.4	6.0	5.1	4.0	2.8	2.3	1.1	0.5	0.5	0.5
95- 115	20					13.2	11.7	9.3	7.3	5.9	4.8	3.9	2.7	2.2	1.0	0.5	0.5	0.5
115- 125	10					13.7	12.4	8.8	7.0	5.7	4.5	3.7	2.6	2.1	1.0	0.5	0.5	0.5
125- 150	25					10.8	9.5	8.0	6.4	5.2	4.4	3.4	2.6	2.0	1.0	0.5	0.5	0.5
150- 175	25					8.2	7.6	6.5	5.5	4.6	3.9	3.3	2.5	1.8	1.0	0.5	0.5	0.5
175- 200	25					6.4	5.8	5.4	4.9	4.2	3.7	3.0	2.3	1.8	0.8	0.5	0.5	0.5
200- 225	25					5.4	4.9	4.5	4.2	3.8	3.1	2.7	2.1	1.6	0.8	0.5	0.4	0.4

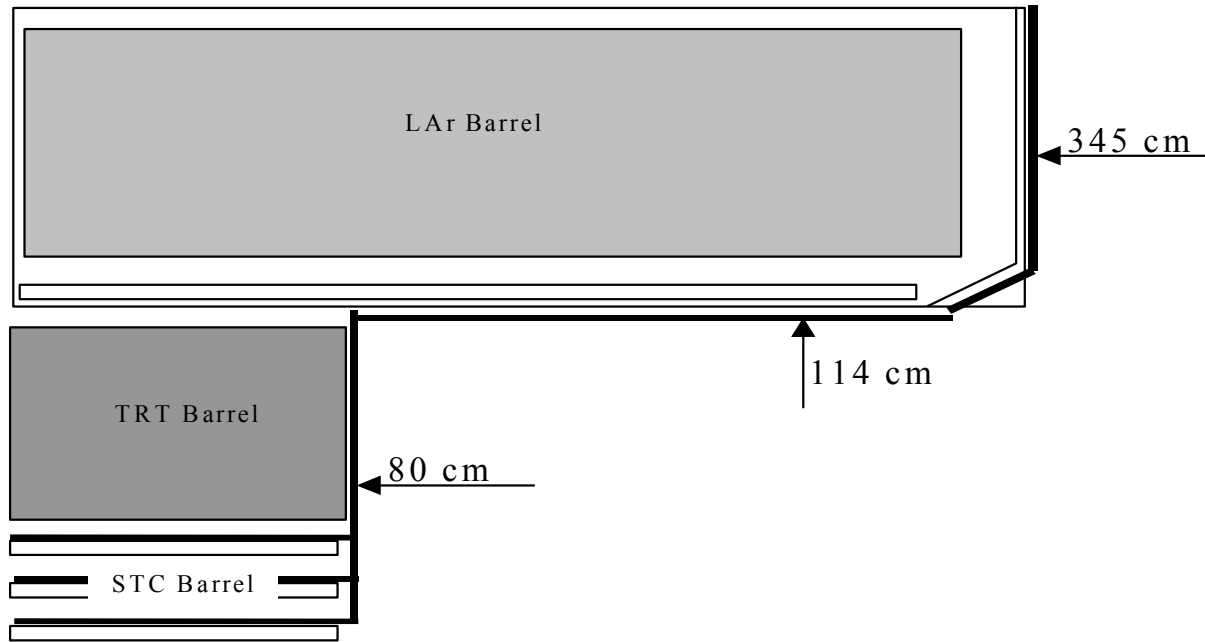

Fig. A6.1 Detector opening layout to calculations of access dose rate – EndCap removed on one side.

Table A6.1

Equivalent dose rate in the ID access scenario for T= 100 d, t= 5 d -- EndCap removed on one side

R/Z, cm	dR/dZ	0- 40	40- 80	80	80- 90	90- 100	100- 110	110- 120	120- 140	140- 160	160- 180	180- 200	200- 240	240- 280	280- 320	320- 360
		40	40	0	10	10	10	10	20	20	20	20	40	40	40	40
0- 5	5			20.8	20.7	19.9	19.1	18.7	18.8	18.5	17.7	16.4	16.9	14.9	13.1	11.3
5- 10	5			20.8	20.8	19.9	19.1	18.6	18.9	18.5	17.8	16.4	16.9	14.9	13.1	11.3
10- 20	10			21.1	20.7	19.9	19.2	18.6	19.0	18.5	18.0	16.7	16.8	15.0	13.2	11.3
20- 30	10			21.8	21.3	20.1	19.2	18.7	19.1	18.6	18.0	17.4	16.9	15.1	13.3	11.3
30- 40	10			22.2	21.7	20.4	19.5	19.1	19.1	18.4	18.1	17.6	17.1	15.3	13.5	11.4
40- 50	10			23.0	22.2	20.6	19.5	19.8	19.1	18.5	18.3	17.7	17.2	15.5	13.6	11.6
50- 65	15			24.0	23.0	20.8	19.7	19.8	19.2	18.6	18.3	17.9	17.3	15.9	13.9	11.7
65- 80	15			24.3	23.3	20.9	19.7	19.0	19.3	18.8	18.5	18.2	17.8	16.4	14.3	12.0
80- 95	15			23.9	22.8	20.7	19.8	19.3	19.6	19.3	19.0	18.9	18.5	18.0	15.4	12.5
95- 110	15			22.7	22.2	20.8	20.3	20.2	20.9	20.6	20.2	20.2	20.0	19.7	17.5	13.6

Table A6.1 (continuation)

Equivalent dose rate in the ID access scenario for T= 100 d, t= 15 d -- EndCap removed on one side

R/Z, cm	dR/dZ	0- 40	40- 80	80	80- 90	90- 100	100- 110	110- 120	120- 140	140- 160	160- 180	180- 200	200- 240	240- 280	280- 320	320- 360
		40	40	0	10	10	10	10	20	20	20	20	40	40	40	40
0- 5	5			15.0	14.9	14.5	14.0	13.8	13.3	12.9	12.3	11.7	11.4	10.7	9.3	7.7
5- 10	5			15.1	15.2	14.5	14.0	13.7	13.3	12.9	12.3	11.7	11.4	10.7	9.3	7.7
10- 20	10			15.4	15.3	14.5	14.1	13.7	13.4	13.0	12.3	11.8	11.5	10.6	9.3	7.8
20- 30	10			16.0	15.6	14.9	14.4	13.8	13.4	13.0	12.3	12.1	11.6	10.6	9.3	7.9
30- 40	10			16.3	15.9	15.0	14.3	13.8	13.4	12.9	12.5	12.1	11.7	10.8	9.4	7.9
40- 50	10			17.1	16.3	15.3	14.7	14.0	13.4	13.0	12.6	12.3	11.9	10.9	9.5	8.0
50- 65	15			17.8	16.9	15.2	14.5	14.1	13.6	13.2	12.6	12.4	12.2	11.3	9.8	8.1
65- 80	15			17.9	17.0	15.5	14.6	14.1	13.8	13.4	13.0	12.8	12.6	11.8	10.2	8.5
80- 95	15			17.7	16.7	15.2	14.6	14.1	14.1	13.7	13.7	13.4	13.3	12.6	10.8	8.8
95- 110	15			16.8	16.4	15.5	15.0	15.0	14.7	14.8	14.7	14.8	14.8	14.1	12.4	9.7

Table A6.1 (continuation)

Equivalent dose rate in the ID access scenario for T= 100 d, t= 30 d -- EndCap removed on one side

R/Z, cm	dR/dZ	0- 40	40- 80	80	80- 90	90- 100	100- 110	110- 120	120- 140	140- 160	160- 180	180- 200	200- 240	240- 280	280- 320	320- 360
		40	40	0	10	10	10	10	20	20	20	20	40	40	40	40
0- 5	5			12.2	12.0	11.5	11.3	10.8	10.2	9.9	9.4	9.2	9.0	8.2	6.9	6.0
5- 10	5			12.3	12.1	11.8	11.3	10.8	10.2	9.9	9.5	9.2	9.1	8.2	6.9	6.0
10- 20	10			12.4	12.2	11.8	11.4	10.8	10.1	9.9	9.5	9.2	9.1	8.2	6.9	6.0
20- 30	10			12.8	12.6	11.9	11.4	10.9	10.2	10.0	9.5	9.3	9.1	8.3	7.0	6.0
30- 40	10			13.2	12.9	12.1	11.5	11.0	10.3	10.0	9.7	9.4	9.2	8.5	7.2	6.0
40- 50	10			13.8	13.2	12.3	11.5	11.1	10.5	10.1	9.8	9.4	9.3	8.5	7.2	6.1
50- 65	15			14.5	13.8	12.5	11.6	11.2	10.6	10.2	10.0	9.8	9.5	8.7	7.4	6.2
65- 80	15			14.5	13.7	12.4	11.6	11.3	10.8	10.5	10.2	10.1	9.8	9.0	7.8	6.3
80- 95	15			14.2	13.7	12.3	11.5	11.3	11.1	10.8	10.8	10.8	10.5	9.7	8.4	6.6
95- 110	15			13.7	13.1	12.6	12.3	12.1	11.7	11.6	11.7	11.8	11.8	11.1	9.8	7.4

Table A6.1 (continuation)

Equivalent dose rate in the ID access scenario for T= 100 d, t= 100 d -- EndCap removed on one side

R/Z, cm	dR/dZ	0- 40	40- 80	80	80- 90	90- 100	100- 110	110- 120	120- 140	140- 160	160- 180	180- 200	200- 240	240- 280	280- 320	320- 360
		40	40	0	10	10	10	10	20	20	20	20	40	40	40	40
0- 5	5			7.7	7.4	7.1	6.9	6.7	6.3	5.8	5.7	5.5	5.2	4.8	4.2	3.3
5- 10	5			7.7	7.6	7.1	7.0	6.8	6.3	5.8	5.7	5.5	5.2	4.8	4.2	3.3
10- 20	10			7.8	7.7	7.2	7.0	6.8	6.2	5.8	5.7	5.5	5.2	4.8	4.3	3.3
20- 30	10			8.0	7.9	7.5	7.3	6.9	6.3	5.9	5.7	5.5	5.3	4.8	4.3	3.3
30- 40	10			8.3	8.1	7.5	7.3	6.8	6.3	5.9	5.9	5.7	5.4	4.8	4.4	3.4
40- 50	10			8.8	8.4	7.7	7.3	6.9	6.4	6.0	6.1	5.8	5.6	4.9	4.4	3.5
50- 65	15			9.2	8.7	7.7	7.1	6.7	6.5	6.1	6.1	5.8	5.7	5.1	4.4	3.6
65- 80	15			9.3	8.9	7.7	7.3	6.8	6.3	6.3	6.1	6.0	5.8	5.3	4.5	3.7
80- 95	15			9.1	8.7	7.8	7.5	6.9	6.7	6.6	6.5	6.4	6.3	5.8	5.0	3.9
95- 110	15			8.5	8.4	7.9	7.3	7.4	7.2	7.1	7.1	7.1	6.9	6.5	5.8	4.3

Table A6.1 (continuation)

Equivalent dose rate in the ID access scenario for T= 10 y, t= 5 d -- EndCap removed on one side

R/Z, cm	dR/dZ	0- 40	40- 80	80	80- 90	90- 100	100- 110	110- 120	120- 140	140- 160	160- 180	180- 200	200- 240	240- 280	280- 320	320- 360
		40	40	0	10	10	10	10	20	20	20	20	40	40	40	40
0- 5	5			38.2	37.4	35.5	34.3	33.8	32.0	31.3	30.8	29.8	28.9	26.4	23.4	19.4
5- 10	5			38.3	37.8	36.0	35.0	34.2	32.1	31.2	30.9	29.5	28.9	26.5	23.4	19.5
10- 20	10			38.7	38.1	36.7	35.3	34.3	32.8	31.4	31.0	29.6	28.9	26.5	23.4	19.5
20- 30	10			39.7	39.0	36.9	35.5	34.3	33.0	32.0	31.4	30.1	28.9	26.6	23.6	19.6
30- 40	10			40.7	39.8	37.4	35.6	34.3	33.2	32.1	31.3	30.5	29.0	26.9	23.8	20.0
40- 50	10			42.5	41.1	37.6	35.8	34.5	33.1	32.1	31.4	31.0	29.5	27.6	24.0	20.2
50- 65	15			44.1	42.2	38.0	35.9	34.6	33.2	32.2	31.5	31.0	30.4	28.1	24.7	20.5
65- 80	15			44.2	42.3	37.9	35.7	34.5	33.5	32.4	32.1	31.8	31.2	29.5	25.9	21.3
80- 95	15			43.2	41.4	37.5	35.7	34.7	34.1	33.9	33.9	33.4	32.9	31.3	27.5	22.1
95- 110	15			41.4	40.3	38.2	37.2	37.0	36.5	36.3	36.3	36.5	36.3	35.0	31.5	24.3

Table A6.1 (continuation)

Equivalent dose rate in the ID access scenario for T= 10 y, t= 15 d -- EndCap removed on one side

R/Z, cm	dR/dZ	0- 40	40- 80	80	80- 90	90- 100	100- 110	110- 120	120- 140	140- 160	160- 180	180- 200	200- 240	240- 280	280- 320	320- 360
		40	40	0	10	10	10	10	20	20	20	20	40	40	40	40
0- 5	5			31.9	31.3	29.6	28.4	27.6	26.6	26.1	25.3	24.5	23.6	21.8	19.1	16.0
5- 10	5			32.1	31.7	29.7	28.4	27.6	26.6	26.1	25.3	24.6	23.6	21.8	19.1	16.0
10- 20	10			32.4	32.0	30.4	29.2	27.8	26.7	26.0	25.3	24.6	24.0	21.8	19.2	16.1
20- 30	10			33.2	32.6	30.9	29.7	28.4	27.0	25.9	25.4	24.6	24.2	21.8	19.5	16.3
30- 40	10			34.2	33.4	31.1	29.8	28.8	27.8	26.8	25.8	24.7	24.4	22.1	19.6	16.5
40- 50	10			35.7	34.6	31.5	29.9	29.0	27.8	27.0	26.4	25.0	24.5	22.7	19.8	16.8
50- 65	15			37.1	35.6	31.8	30.1	29.0	27.9	26.9	26.4	26.1	25.0	23.4	20.3	17.0
65- 80	15			37.1	35.4	31.8	29.9	28.9	28.2	27.4	26.6	26.5	26.2	24.5	21.3	17.5
80- 95	15			36.1	34.6	31.3	30.0	29.5	28.8	28.3	28.2	28.2	27.4	26.0	22.9	18.4
95- 110	15			35.2	34.2	32.5	31.5	31.3	30.9	30.5	30.3	30.7	30.5	29.3	26.3	19.9

Table A6.1 (continuation)

Equivalent dose rate in the ID access scenario for T= 10 y, t= 30 d -- EndCap removed on one side

R/Z, cm	dR/dZ	0- 40	40- 80	80	80- 90	90- 100	100- 110	110- 120	120- 140	140- 160	160- 180	180- 200	200- 240	240- 280	280- 320	320- 360
		40	40	0	10	10	10	10	20	20	20	20	40	40	40	40
0- 5	5			28.7	28.4	27.3	26.3	24.6	23.6	22.9	22.1	21.6	20.6	19.0	16.8	14.1
5- 10	5			28.7	28.5	27.3	26.3	25.0	23.6	22.8	22.1	21.6	20.6	19.0	16.8	14.0
10- 20	10			29.1	28.7	27.3	26.4	25.4	23.7	23.0	22.1	21.6	20.8	19.1	16.9	14.0
20- 30	10			29.7	29.3	27.6	26.4	25.6	24.2	22.9	22.1	21.8	21.3	19.2	17.0	14.2
30- 40	10			30.6	30.0	27.9	26.5	25.7	24.7	23.8	22.7	21.8	21.4	19.4	17.1	14.5
40- 50	10			32.0	30.8	28.3	26.7	25.5	24.7	24.0	23.3	22.2	21.6	19.8	17.3	14.6
50- 65	15			33.1	31.8	28.5	26.8	25.8	24.8	24.0	23.4	23.1	22.1	20.7	17.8	14.8
65- 80	15			33.2	31.5	28.3	26.8	25.7	24.9	24.1	23.7	23.6	23.1	21.6	18.7	15.1
80- 95	15			32.9	31.5	28.4	27.1	26.5	25.8	25.4	25.1	24.7	24.3	23.0	20.2	15.8
95- 110	15			31.6	30.7	29.0	28.2	27.8	27.5	27.1	27.1	27.3	27.2	25.8	23.4	17.5

Table A6.1 (continuation)

Equivalent dose rate in the ID access scenario for T= 10 y, t= 100 d -- EndCap removed on one side

R/Z, cm	dR/dZ	0- 40	40- 80	80	80- 90	90- 100	100- 110	110- 120	120- 140	140- 160	160- 180	180- 200	200- 240	240- 280	280- 320	320- 360
		40	40	0	10	10	10	10	20	20	20	20	40	40	40	40
0- 5	5			22.4	22.2	21.3	20.6	20.0	18.6	17.8	17.3	17.3	16.2	14.9	13.0	10.8
5- 10	5			22.6	22.2	21.3	20.6	20.0	18.6	17.8	17.3	17.2	16.1	14.9	13.0	10.8
10- 20	10			22.9	22.6	21.7	20.8	20.1	18.9	17.7	17.2	16.9	16.3	15.1	13.0	11.0
20- 30	10			23.6	23.0	21.8	20.9	20.4	19.4	18.3	17.4	16.9	16.5	15.1	13.1	11.0
30- 40	10			24.1	23.6	22.0	21.0	20.4	19.4	18.7	18.0	17.0	16.5	15.3	13.4	11.1
40- 50	10			25.2	24.3	22.4	21.0	20.2	19.5	18.6	18.2	17.6	16.7	15.5	13.5	11.2
50- 65	15			26.2	25.1	22.3	21.2	20.4	19.4	18.8	18.2	18.0	17.5	16.0	14.1	11.5
65- 80	15			26.2	24.9	22.4	20.9	20.1	19.4	18.9	18.6	18.5	18.3	16.8	14.7	11.7
80- 95	15			26.4	25.3	22.8	21.6	21.1	20.5	20.0	19.9	19.7	19.1	18.0	16.0	12.4
95- 110	15			25.1	24.5	23.0	22.3	21.9	21.6	21.4	21.2	21.6	21.7	20.3	18.3	13.5

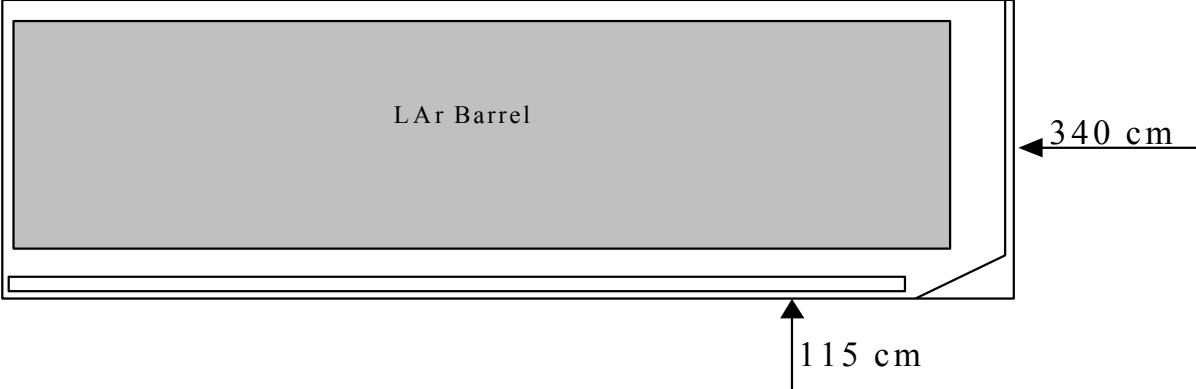

Fig. A6.2 Detector opening layout to calculations of access dose rate – Inner Detector removed

Table A6.2

Equivalent dose rate in the ID access scenario for T= 100 d, t= 5 d -- Inner Detector removed

R/Z, cm	dR/dZ	0- 40	40- 80	80	80- 90	90- 100	100- 110	110- 120	120- 140	140- 160	160- 180	180- 200	200- 240	240- 280	280- 320	320- 360
		40	40	0	10	10	10	10	20	20	20	20	40	40	40	40
0- 5	5	10.7	10.7	10.7	10.7	10.7	10.7	10.7	11.5	11.7	11.4	10.7	11.4	10.4	9.1	8
5- 10	5	10.7	10.7	10.7	10.7	10.7	10.7	10.7	11.5	11.7	11.5	10.7	11.4	10.4	9.1	8
10- 20	10	10.7	10.7	10.7	10.7	10.7	10.7	10.7	11.6	11.7	11.7	11	11.5	10.4	9.1	8
20- 30	10	10.7	10.7	10.7	10.7	10.7	10.7	10.7	11.7	11.7	11.7	11.5	11.6	10.4	9.1	8
30- 40	10	10.7	10.7	10.7	10.7	10.7	10.7	11	11.7	11.7	11.7	11.7	11.7	10.5	9.2	8
40- 50	10	10.7	10.7	10.7	10.7	10.7	10.8	11.6	11.7	11.7	11.7	11.7	11.6	10.6	9.2	8.1
50- 65	15	10.7	10.7	10.7	10.7	10.7	10.8	11.5	11.7	11.7	11.7	11.7	11.5	10.7	9.3	8.1
65- 80	15	10.7	10.7	10.7	10.7	10.7	10.7	10.8	11.7	11.7	11.7	11.7	11.7	10.8	9.4	8.2
80- 95	15	10.7	10.7	10.7	10.7	10.7	10.7	10.7	11.6	11.7	11.7	11.7	11.7	11.6	9.6	8.2
95- 110	15	10.6	10.6	10.6	10.7	10.7	10.7	10.8	11.7	11.7	11.7	11.7	11.7	11.8	10	8.4

Table A6.2 (continuation)

Equivalent dose rate in the ID access scenario for T= 100 d, t= 15 d -- Inner Detector removed

R/Z, cm	dR/dZ	0- 40	40- 80	80	80- 90	90- 100	100- 110	110- 120	120- 140	140- 160	160- 180	180- 200	200- 240	240- 280	280- 320	320- 360
		40	40	0	10	10	10	10	20	20	20	20	40	40	40	40
0- 5	5	7.6	7.6	7.6	7.6	7.8	7.8	7.8	7.8	7.8	7.9	7.7	7.7	7.1	6.2	5.2
5- 10	5	7.6	7.6	7.6	7.7	7.8	7.8	7.8	7.8	7.8	7.9	7.7	7.7	7.1	6.2	5.2
10- 20	10	7.7	7.7	7.7	7.7	7.8	7.8	7.8	7.9	7.9	7.9	7.7	7.7	7.1	6.2	5.3
20- 30	10	7.7	7.7	7.7	7.7	7.8	7.8	7.8	7.9	7.9	7.8	7.8	7.8	7.1	6.2	5.3
30- 40	10	7.7	7.7	7.7	7.7	7.8	7.8	7.8	7.9	7.9	7.9	7.8	7.8	7.2	6.2	5.3
40- 50	10	7.7	7.7	7.7	7.7	7.9	7.9	7.9	7.9	7.9	8	7.9	7.8	7.3	6.2	5.3
50- 65	15	7.7	7.7	7.7	7.7	7.8	7.9	7.9	8	8	8	8	8	7.4	6.3	5.4
65- 80	15	7.7	7.7	7.7	7.7	7.8	7.9	7.9	8	8.1	8.1	8.1	8.1	7.6	6.4	5.5
80- 95	15	7.8	7.8	7.8	7.8	7.8	7.9	7.9	8.1	8.2	8.3	8.3	8.2	7.8	6.5	5.5
95- 110	15	7.8	7.8	7.8	7.8	7.9	7.9	8	8.1	8.3	8.4	8.5	8.5	8	6.8	5.6

Table A6.2 (continuation)

Equivalent dose rate in the ID access scenario for T= 100 d, t= 30 d -- Inner Detector removed

R/Z, cm	dR/dZ	0- 40	40- 80	80	80- 90	90- 100	100- 110	110- 120	120- 140	140- 160	160- 180	180- 200	200- 240	240- 280	280- 320	320- 360
		40	40	0	10	10	10	10	20	20	20	20	40	40	40	40
0- 5	5	6	6	6	5.9	5.9	6	6	6	6	5.9	5.9	5.8	5.3	4.5	3.9
5- 10	5	6	6	6	6	6	6	6	6	6	6	5.9	5.9	5.3	4.5	3.9
10- 20	10	6	6	6	6	6	6	6	6	6	6	5.9	5.9	5.3	4.5	3.9
20- 30	10	6	6	6	6	6	6	6	6.1	6.1	6	5.9	5.8	5.3	4.5	3.9
30- 40	10	6	6	6	6	6	6	6	6.1	6.1	6.1	6	5.9	5.4	4.6	3.9
40- 50	10	6.1	6.1	6.1	6.1	6.1	6	6	6.1	6.2	6.2	6	5.9	5.5	4.6	3.9
50- 65	15	6.1	6.1	6.1	6.1	6.1	6.1	6.1	6.1	6.2	6.2	6.2	6	5.6	4.7	4
65- 80	15	6.1	6.1	6.1	6.1	6.1	6.1	6.2	6.2	6.2	6.3	6.3	6.2	5.7	4.8	4
80- 95	15	6.2	6.2	6.2	6.2	6.2	6.2	6.2	6.3	6.3	6.5	6.5	6.4	5.9	4.9	4
95- 110	15	6.2	6.2	6.2	6.2	6.3	6.3	6.4	6.4	6.5	6.6	6.7	6.7	6.2	5.1	4.1

Table A6.2 (continuation)

Equivalent dose rate in the ID access scenario for T= 100 d, t= 100 d -- Inner Detector removed

R/Z, cm	dR/dZ	0- 40	40- 80	80	80- 90	90- 100	100- 110	110- 120	120- 140	140- 160	160- 180	180- 200	200- 240	240- 280	280- 320	320- 360
		40	40	0	10	10	10	10	20	20	20	20	40	40	40	40
0- 5	5	3.7	3.6	3.7	3.6	3.6	3.7	3.6	3.7	3.6	3.6	3.6	3.4	3.2	2.7	2.3
5- 10	5	3.7	3.7	3.7	3.7	3.6	3.7	3.7	3.7	3.6	3.6	3.6	3.4	3.2	2.7	2.3
10- 20	10	3.7	3.7	3.7	3.7	3.7	3.7	3.7	3.7	3.6	3.6	3.6	3.4	3.2	2.8	2.3
20- 30	10	3.7	3.7	3.7	3.7	3.7	3.8	3.7	3.7	3.7	3.6	3.6	3.5	3.2	2.8	2.3
30- 40	10	3.7	3.7	3.7	3.7	3.7	3.8	3.8	3.7	3.7	3.7	3.6	3.5	3.2	2.8	2.3
40- 50	10	3.7	3.7	3.7	3.7	3.7	3.8	3.8	3.8	3.8	3.8	3.7	3.6	3.2	2.8	2.4
50- 65	15	3.7	3.7	3.7	3.7	3.7	3.7	3.8	3.8	3.8	3.8	3.8	3.7	3.3	2.8	2.4
65- 80	15	3.8	3.8	3.8	3.8	3.8	3.8	3.8	3.8	3.9	3.9	3.9	3.8	3.4	2.9	2.4
80- 95	15	3.8	3.9	3.8	3.9	3.9	3.9	3.9	3.9	3.9	4	4	3.9	3.6	3.1	2.4
95- 110	15	3.9	3.9	3.9	3.9	4	4	4	4	4	4.2	4.2	4.2	3.8	3.3	2.5

Table A6.2 (continuation)

Equivalent dose rate in the ID access scenario for T= 10 y, t= 5 d -- Inner Detector removed

R/Z, cm	dR/dZ	0- 40	40- 80	80	80- 90	90- 100	100- 110	110- 120	120- 140	140- 160	160- 180	180- 200	200- 240	240- 280	280- 320	320- 360
		40	40	0	10	10	10	10	20	20	20	20	40	40	40	40
0- 5	5	20.4	20.4	20.4	20	19.5	19.5	20.2	19.7	20	20.3	20.1	20	18.4	16.2	13.8
5- 10	5	20.4	20.4	20.4	20.3	19.9	20.2	20.5	19.8	19.9	20.4	19.8	20	18.4	16.2	13.9
10- 20	10	20.4	20.4	20.4	20.4	20.5	20.5	20.5	20.4	20.1	20.5	19.8	20	18.4	16.2	13.9
20- 30	10	20.4	20.4	20.4	20.4	20.5	20.5	20.5	20.6	20.7	20.8	20.2	19.9	18.5	16.4	14
30- 40	10	20.4	20.4	20.4	20.4	20.5	20.5	20.5	20.6	20.7	20.7	20.6	19.9	18.7	16.4	14.2
40- 50	10	20.4	20.4	20.4	20.4	20.4	20.5	20.6	20.6	20.6	20.7	20.8	20.3	19.2	16.5	14.3
50- 65	15	20.4	20.4	20.4	20.4	20.4	20.5	20.5	20.6	20.6	20.6	20.7	20.6	19.4	16.8	14.5
65- 80	15	20.4	20.4	20.4	20.4	20.4	20.4	20.5	20.5	20.5	20.6	21	20.9	20	17.3	14.7
80- 95	15	20.3	20.3	20.3	20.3	20.4	20.4	20.4	20.7	21.2	21.6	21.7	21.4	20.6	17.9	14.9
95- 110	15	20.3	20.3	20.3	20.3	20.7	21.1	21.4	21.4	21.5	21.9	22.4	22.4	21.5	19	15.5

Table A6.2 (continuation)

Equivalent dose rate in the ID access scenario for T= 10 y, t= 15 d -- Inner Detector removed

R/Z, cm	dR/dZ	0- 40	40- 80	80	80- 90	90- 100	100- 110	110- 120	120- 140	140- 160	160- 180	180- 200	200- 240	240- 280	280- 320	320- 360
		40	40	0	10	10	10	10	20	20	20	20	40	40	40	40
0- 5	5	17.1	17.1	17.1	16.7	16.1	16.2	16.2	16.2	16.5	16.6	16.4	15.9	15.0	13.3	11.2
5- 10	5	17.1	17.1	17.1	17.0	16.2	16.2	16.2	16.2	16.5	16.6	16.4	15.9	15.0	13.3	11.2
10- 20	10	17.1	17.1	17.1	17.1	16.9	16.8	16.3	16.3	16.4	16.5	16.4	16.3	15.0	13.4	11.2
20- 30	10	17.1	17.1	17.1	17.1	17.1	17.2	16.9	16.5	16.4	16.5	16.5	16.6	15.0	13.4	11.3
30- 40	10	17.1	17.1	17.1	17.1	17.1	17.2	17.2	17.3	17.1	16.9	16.5	16.6	15.1	13.5	11.4
40- 50	10	17.1	17.1	17.1	17.1	17.1	17.2	17.2	17.3	17.3	17.4	16.7	16.6	15.4	13.5	11.6
50- 65	15	17.1	17.1	17.1	17.1	17.1	17.2	17.2	17.2	17.3	17.3	17.3	16.9	15.9	13.7	11.6
65- 80	15	17.0	17.0	17.0	17.1	17.1	17.1	17.1	17.2	17.2	17.3	17.4	17.4	16.3	14.1	11.9
80- 95	15	17.0	17.0	17.0	17.0	17.0	17.2	17.4	17.4	17.7	18.0	18.1	17.8	16.9	14.7	12.1
95- 110	15	17.7	17.7	17.7	17.7	18.0	18.0	18.0	18.1	18.1	18.3	18.8	18.7	17.8	15.7	12.5

Table A6.2 (continuation)

Equivalent dose rate in the ID access scenario for T= 10 y, t= 30 d -- Inner Detector removed

R/Z, cm	dR/dZ	0- 40	40- 80	80	80- 90	90- 100	100- 110	110- 120	120- 140	140- 160	160- 180	180- 200	200- 240	240- 280	280- 320	320- 360
		40	40	0	10	10	10	10	20	20	20	20	40	40	40	40
0- 5	5	15.1	15.1	15.1	15.1	15.1	15.1	14.2	14.2	14.5	14.5	14.4	13.9	13.0	11.5	9.8
5- 10	5	15.1	15.1	15.1	15.1	15.1	15.1	14.6	14.2	14.4	14.5	14.4	13.9	13.0	11.5	9.7
10- 20	10	15.1	15.1	15.1	15.1	15.1	15.1	15.1	14.3	14.4	14.5	14.4	14.1	13.0	11.5	9.7
20- 30	10	15.1	15.1	15.1	15.1	15.1	15.1	15.2	14.8	14.4	14.4	14.5	14.5	13.0	11.6	9.9
30- 40	10	15.1	15.1	15.1	15.1	15.1	15.1	15.2	15.3	15.3	14.9	14.5	14.6	13.2	11.6	10.0
40- 50	10	15.0	15.0	15.0	15.0	15.1	15.1	15.2	15.2	15.3	15.3	14.6	14.6	13.4	11.7	10.0
50- 65	15	15.0	15.0	15.0	15.0	15.1	15.1	15.2	15.2	15.2	15.3	15.3	14.8	14.0	11.9	10.1
65- 80	15	15.0	15.0	15.0	15.0	15.0	15.1	15.1	15.1	15.2	15.2	15.4	15.4	14.3	12.4	10.3
80- 95	15	15.5	15.5	15.5	15.5	15.5	15.6	15.7	15.8	15.8	15.9	16.0	15.8	14.9	12.9	10.5
95- 110	15	15.9	15.9	15.9	15.9	15.9	16.0	16.0	16.0	16.1	16.4	16.8	16.7	15.7	14.0	11.0

Table A6.2 (continuation)

Equivalent dose rate in the ID access scenario for T= 10 y, t= 100 d -- Inner Detector removed

R/Z, cm	dR/dZ	0- 40	40- 80	80	80- 90	90- 100	100- 110	110- 120	120- 140	140- 160	160- 180	180- 200	200- 240	240- 280	280- 320	320- 360
		40	40	0	10	10	10	10	20	20	20	20	40	40	40	40
0- 5	5	12.0	12.0	12.0	12.0	12.0	12.0	12.0	11.5	11.3	11.4	11.7	11.1	10.4	9.2	7.7
5- 10	5	12.0	12.0	12.0	12.0	12.0	12.0	12.0	11.5	11.3	11.4	11.6	11.1	10.4	9.2	7.7
10- 20	10	12.0	12.0	12.0	12.0	12.0	12.0	12.0	11.7	11.2	11.3	11.2	11.3	10.5	9.2	7.9
20- 30	10	12.0	12.0	12.0	12.0	12.0	12.0	12.0	12.1	11.8	11.5	11.3	11.4	10.5	9.2	7.9
30- 40	10	11.9	11.9	11.9	11.9	12.0	12.0	12.1	12.1	12.2	12.0	11.3	11.4	10.6	9.3	8.0
40- 50	10	11.9	11.9	11.9	11.9	12.0	12.0	12.1	12.1	12.1	12.2	11.8	11.4	10.8	9.4	8.0
50- 65	15	11.9	11.9	11.9	11.9	11.9	12.0	12.0	12.1	12.1	12.1	12.2	11.9	11.0	9.7	8.2
65- 80	15	11.9	11.9	11.9	11.9	11.9	11.9	12.0	12.0	12.0	12.1	12.2	12.3	11.4	10.0	8.3
80- 95	15	12.7	12.7	12.7	12.7	12.7	12.7	12.7	12.8	12.8	12.9	12.9	12.6	11.9	10.6	8.6
95- 110	15	12.8	12.8	12.8	12.8	12.8	12.8	12.9	12.9	13.0	13.1	13.5	13.6	12.8	11.5	8.9

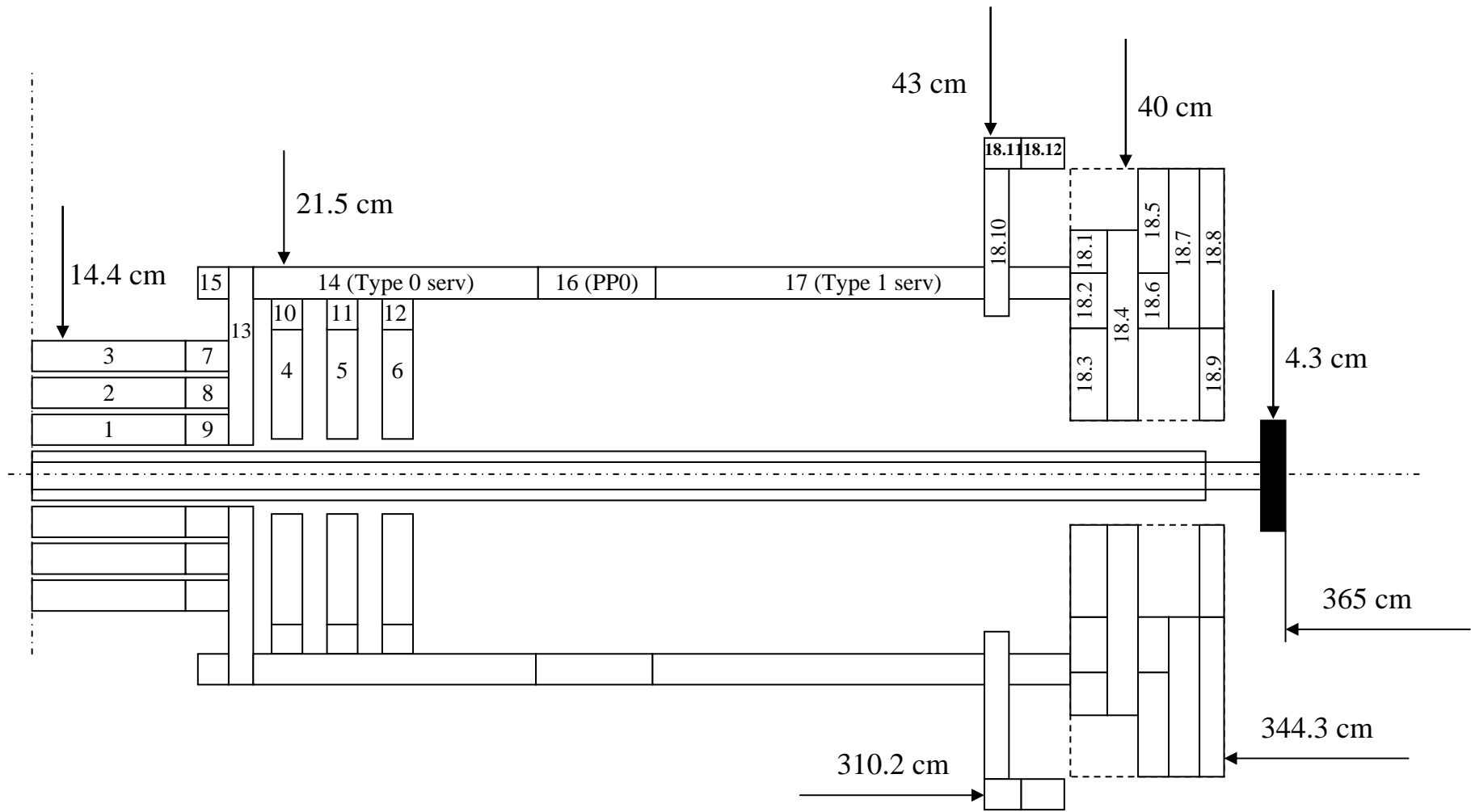

Fig. A7.0 Scenario 0-- Pixel Detector with VI beam pipe section (PST removed).

Table A7.01

Equivalent dose rate from Pixel + VI, Scenario 0 for T= 100d, t= 5d

R\Z	0	20	40	50	70	88.5	107	150	200	250	300	325	335	345	365	380	400
0															72.72	11.47	5.50
5														55.26	72.14	11.18	5.48
10														51.58	23.90	10.48	5.40
15	61.70	67.05	104.39											41.45	17.41	9.66	5.27
23	35.85	37.47	45.21	40.14	24.27	17.18	12.39	7.23	6.80	9.06	31.49			29.93	13.44	8.47	5.01
30	26.07	26.83	28.22	25.78	17.61	12.70	9.44	5.88	5.47	7.57	27.22			23.36	11.38	7.58	4.73
40	18.23	18.37	17.92	16.66	12.75	9.71	7.54	5.01	4.63	6.47	20.54		21.20	16.24	9.19	6.50	4.32
50	13.57	13.49	12.84	12.04	9.84	7.88	6.37	4.45	4.12	5.65	14.12	17.62	13.94	11.29	7.48	5.58	3.91
75	7.61	7.48	7.09	6.77	5.99	5.23	4.55	3.52	3.30	4.15	6.41	6.71	6.33	5.80	4.63	3.84	2.99
100	4.92	4.86	4.65	4.50	4.14	3.78	3.44	2.89	2.72	3.12	3.82	3.83	3.72	3.55	3.10	2.74	2.29
125	3.48	3.45	3.35	3.27	3.09	2.91	2.73	2.40	2.27	2.42	2.65	2.59	2.53	2.45	2.24	2.05	1.79
150	2.64	2.61	2.55	2.52	2.41	2.32	2.21	2.00	1.90	1.93	1.98	1.93	1.89	1.84	1.70	1.60	1.44
200	1.69	1.68	1.66	1.64	1.61	1.57	1.54	1.45	1.37	1.34	1.28	1.24	1.21	1.19	1.13	1.08	1.01
250	1.20	1.20	1.19	1.19	1.16	1.15	1.13	1.09	1.03	0.99	0.94	0.89	0.88	0.86	0.83	0.79	0.75

Table A7.01 (continuation)

Equivalent dose rate from Pixel + VI, Scenario 0 for T= 100d, t= 7 d

R\Z	0	20	40	50	70	88.5	107	150	200	250	300	325	335	345	365	380	400
0															67.70	95.69	100.36
5														50.83	67.16	105.02	197.18
10														47.24	22.11	81.99	168.02
15	55.50	60.45	95.72											38.00	16.06	55.50	60.45
23	32.34	33.89	41.24	36.82	22.30	15.74	11.39	6.71	6.33	8.40	28.97			27.47	12.38	32.34	33.89
30	23.57	24.31	25.71	23.58	16.14	11.63	8.67	5.44	5.07	7.01	25.04			21.45	10.47	23.57	24.31
40	16.52	16.68	16.33	15.21	11.68	8.90	6.92	4.62	4.28	5.97	18.90		19.49	14.93	8.45	16.52	16.68
50	12.32	12.26	11.69	10.99	9.00	7.22	5.84	4.10	3.81	5.22	12.98	16.25	12.84	10.39	6.87	12.32	12.26
75	6.92	6.81	6.46	6.18	5.48	4.78	4.17	3.25	3.04	3.82	5.91	6.18	5.82	5.34	4.27	6.92	6.81
100	4.48	4.42	4.23	4.11	3.79	3.46	3.16	2.64	2.51	2.88	3.53	3.54	3.43	3.27	2.85	4.48	4.42
125	3.18	3.14	3.05	2.98	2.82	2.65	2.49	2.19	2.08	2.22	2.43	2.38	2.33	2.25	2.06	3.18	3.14
150	2.40	2.38	2.33	2.29	2.21	2.11	2.01	1.83	1.75	1.78	1.81	1.77	1.73	1.69	1.58	2.40	2.38
200	1.54	1.54	1.52	1.51	1.48	1.44	1.40	1.33	1.27	1.22	1.18	1.14	1.12	1.10	1.04	1.54	1.54
250	1.09	1.08	1.08	1.07	1.06	1.05	1.03	0.99	0.94	0.90	0.86	0.82	0.80	0.79	0.76	1.09	1.08

Table A7.01 (continuation)

Equivalent dose rate from Pixel + VI, Scenario 0 for T= 100d, t= 15 d

R\Z	0	20	40	50	70	88.5	107	150	200	250	300	325	335	345	365	380	400
0															60.68	73.60	77.49
5														42.23	60.27	80.43	149.58
10														38.35	19.03	63.00	128.95
15	42.90	46.96	76.75											30.98	13.55	42.90	46.96
23	25.18	26.52	32.78	30.00	18.32	12.74	9.34	5.74	5.46	7.14	23.54			22.48	10.29	25.18	26.52
30	18.45	19.11	20.52	19.03	13.16	9.45	7.11	4.58	4.31	5.88	20.32			17.58	8.68	18.45	19.11
40	13.00	13.16	13.04	12.21	9.45	7.22	5.66	3.85	3.60	4.97	15.37		16.07	12.27	6.97	13.00	13.16
50	9.74	9.71	9.33	8.81	7.26	5.85	4.76	3.39	3.17	4.33	10.61	13.51	10.63	8.57	5.66	9.74	9.71
75	5.51	5.43	5.17	4.96	4.41	3.87	3.38	2.66	2.51	3.16	4.85	5.08	4.80	4.40	3.50	5.51	5.43
100	3.59	3.54	3.40	3.31	3.06	2.81	2.57	2.17	2.05	2.36	2.90	2.90	2.81	2.68	2.35	3.59	3.54
125	2.55	2.53	2.45	2.40	2.28	2.15	2.02	1.79	1.71	1.83	1.99	1.96	1.91	1.85	1.69	2.55	2.53
150	1.94	1.92	1.88	1.86	1.78	1.72	1.64	1.50	1.43	1.46	1.50	1.46	1.42	1.38	1.29	1.94	1.92
200	1.25	1.24	1.23	1.22	1.19	1.16	1.14	1.07	1.03	1.01	0.98	0.93	0.91	0.89	0.85	1.25	1.24
250	0.89	0.88	0.88	0.87	0.86	0.85	0.84	0.80	0.77	0.74	0.70	0.67	0.66	0.65	0.62	0.89	0.88

Table A7.01 (continuation)

Equivalent dose rate from Pixel + VI, Scenario 0 for T= 100d, t= 30 d

R\Z	0	20	40	50	70	88.5	107	150	200	250	300	325	335	345	365	380	400
0															55.11	55.92	59.04
5														34.60	54.67	60.90	112.18
10														30.49	16.39	47.97	98.26
15	32.87	36.15	60.42											24.75	11.35	32.87	36.15
23	19.40	20.54	25.73	24.20	14.87	10.13	7.53	4.85	4.65	5.95	18.58			18.04	8.45	19.40	20.54
30	14.28	14.87	16.16	15.17	10.58	7.54	5.73	3.81	3.61	4.84	15.99			14.12	7.06	14.28	14.87
40	10.12	10.29	10.27	9.69	7.55	5.77	4.55	3.16	2.97	4.05	12.15		13.02	9.90	5.66	10.12	10.29
50	7.60	7.61	7.37	6.99	5.79	4.68	3.83	2.77	2.61	3.51	8.44	11.02	8.63	6.93	4.59	7.60	7.61
75	4.34	4.29	4.09	3.92	3.50	3.09	2.70	2.15	2.05	2.55	3.89	4.09	3.86	3.54	2.83	4.34	4.29
100	2.83	2.80	2.70	2.62	2.43	2.24	2.05	1.74	1.66	1.91	2.32	2.33	2.26	2.16	1.89	2.83	2.80
125	2.02	2.00	1.96	1.91	1.81	1.71	1.61	1.43	1.38	1.48	1.60	1.58	1.54	1.49	1.37	2.02	2.00
150	1.53	1.52	1.49	1.47	1.42	1.36	1.31	1.19	1.15	1.17	1.20	1.18	1.15	1.11	1.03	1.53	1.52
200	1.00	1.00	0.98	0.97	0.96	0.94	0.92	0.87	0.83	0.81	0.78	0.75	0.73	0.72	0.69	1.00	1.00
250	0.70	0.70	0.70	0.70	0.69	0.68	0.67	0.64	0.63	0.60	0.55	0.53	0.53	0.52	0.50	0.70	0.70

Table A7.01 (continuation)

Equivalent dose rate from Pixel + VI, Scenario 0 for T= 100d, t= 100 d

R\Z	0	20	40	50	70	88.5	107	150	200	250	300	325	335	345	365	380	400
0															47.17	5.32	2.23
5														22.50	46.80	5.12	2.21
10														18.20	12.31	4.66	2.17
15	18.75	20.64	34.08											14.93	7.89	4.16	2.10
23	11.10	11.76	14.98	14.90	9.22	5.89	4.55	3.29	3.20	3.90	10.38			10.97	5.51	3.47	1.98
30	8.21	8.56	9.48	9.12	6.43	4.48	3.46	2.49	2.38	3.05	8.82			8.55	4.48	3.02	1.85
40	5.84	5.97	6.04	5.76	4.54	3.46	2.76	2.00	1.91	2.49	6.78		8.03	6.03	3.52	2.52	1.66
50	4.41	4.43	4.33	4.13	3.45	2.80	2.31	1.73	1.65	2.14	4.82	6.84	5.33	4.24	2.83	2.14	1.49
75	2.54	2.51	2.41	2.32	2.08	1.84	1.63	1.32	1.26	1.54	2.29	2.44	2.32	2.14	1.73	1.43	1.12
100	1.68	1.65	1.59	1.56	1.45	1.34	1.23	1.06	1.01	1.14	1.39	1.40	1.37	1.30	1.14	1.01	0.85
125	1.20	1.19	1.15	1.13	1.08	1.03	0.97	0.86	0.84	0.89	0.97	0.94	0.92	0.89	0.82	0.75	0.66
150	0.91	0.90	0.89	0.88	0.84	0.81	0.79	0.72	0.70	0.70	0.73	0.70	0.68	0.67	0.62	0.59	0.53
200	0.59	0.59	0.58	0.58	0.56	0.55	0.55	0.52	0.50	0.49	0.46	0.45	0.44	0.43	0.41	0.39	0.37
250	0.42	0.42	0.42	0.42	0.41	0.41	0.40	0.39	0.38	0.35	0.33	0.32	0.32	0.31	0.30	0.29	0.28

Table A7.02

Equivalent dose rate from Pixel + VI, Scenario 0 for T= 10y, t= 5 d

R\Z	0	20	40	50	70	88.5	107	150	200	250	300	325	335	345	365	380	400
0															243.25	26.81	11.06
5														113.44	241.39	25.80	10.99
10														91.62	62.62	23.42	10.77
15	91.79	100.00	153.44											74.64	39.71	20.79	10.45
23	54.06	56.83	70.94	70.35	43.82	28.14	21.99	16.14	15.77	19.11	49.82			54.36	27.46	17.28	9.78
30	39.77	41.22	45.03	43.19	30.56	21.37	16.65	12.13	11.70	14.86	42.11			42.16	22.25	14.95	9.14
40	28.21	28.64	28.79	27.40	21.59	16.51	13.22	9.76	9.33	12.11	32.26		39.45	29.57	17.37	12.42	8.20
50	21.25	21.27	20.69	19.72	16.49	13.40	11.09	8.39	8.01	10.35	23.04	33.25	26.00	20.77	13.89	10.46	7.32
75	12.19	12.04	11.53	11.11	9.99	8.85	7.83	6.36	6.09	7.41	11.08	11.84	11.31	10.43	8.43	7.03	5.48
100	8.02	7.92	7.64	7.44	6.93	6.41	5.92	5.10	4.90	5.55	6.71	6.78	6.61	6.33	5.57	4.94	4.16
125	5.74	5.70	5.54	5.45	5.19	4.93	4.65	4.18	4.02	4.29	4.66	4.60	4.50	4.37	3.99	3.67	3.23
150	4.38	4.36	4.27	4.21	4.07	3.92	3.77	3.49	3.35	3.43	3.49	3.40	3.34	3.26	3.04	2.85	2.58
200	2.85	2.84	2.82	2.80	2.74	2.69	2.63	2.50	2.41	2.35	2.27	2.19	2.15	2.11	2.00	1.91	1.78
250	2.04	2.04	2.03	2.02	1.99	1.97	1.94	1.87	1.80	1.72	1.64	1.57	1.55	1.52	1.45	1.40	1.34

Table A7.02 (continuation)

Equivalent dose rate from Pixel + VI, Scenario 0 for T= 10y, t= 7 d

R\Z	0	20	40	50	70	88.5	107	150	200	250	300	325	335	345	365	380	400
0															236.91	25.85	10.61
5														108.97	235.07	24.87	10.53
10														87.18	60.60	22.55	10.33
15	85.46	93.27	144.55											71.11	38.25	19.98	10.02
23	50.48	53.17	66.85	66.94	41.79	26.69	20.95	15.61	15.26	18.42	47.21			51.83	26.34	16.57	9.38
30	37.21	38.64	42.47	40.91	29.04	20.30	15.87	11.67	11.28	14.28	39.84			40.19	21.28	14.31	8.74
40	26.45	26.90	27.16	25.91	20.49	15.67	12.58	9.36	8.98	11.59	30.56		37.68	28.21	16.60	11.89	7.84
50	19.98	20.01	19.52	18.63	15.62	12.71	10.54	8.03	7.68	9.90	21.88	31.84	24.87	19.84	13.27	10.00	7.00
75	11.49	11.36	10.90	10.51	9.46	8.39	7.44	6.06	5.83	7.08	10.55	11.30	10.78	9.96	8.04	6.70	5.22
100	7.57	7.48	7.22	7.04	6.57	6.08	5.61	4.86	4.67	5.29	6.39	6.47	6.30	6.03	5.31	4.71	3.96
125	5.44	5.39	5.26	5.16	4.91	4.66	4.43	3.98	3.84	4.08	4.44	4.38	4.29	4.16	3.81	3.50	3.08
150	4.14	4.12	4.04	4.00	3.86	3.72	3.58	3.31	3.18	3.26	3.33	3.26	3.18	3.10	2.90	2.72	2.46
200	2.70	2.69	2.66	2.65	2.61	2.55	2.50	2.39	2.29	2.24	2.16	2.08	2.05	2.00	1.90	1.82	1.70
250	1.93	1.93	1.92	1.90	1.89	1.87	1.85	1.78	1.72	1.64	1.55	1.49	1.47	1.44	1.39	1.34	1.27

Table A7.02 (continuation)

Equivalent dose rate from Pixel + VI, Scenario 0 for T= 10y, t= 15 d

R\Z	0	20	40	50	70	88.5	107	150	200	250	300	325	335	345	365	380	400
0															232.02	24.29	9.74
5														100.37	230.22	23.33	9.67
10														78.05	57.81	21.06	9.47
15	72.39	79.26	124.72											63.85	35.80	18.55	9.17
23	43.04	45.51	58.02	59.77	37.60	23.53	18.79	14.55	14.32	17.07	41.54			46.63	24.24	15.25	8.56
30	31.87	33.24	37.03	36.13	25.88	17.99	14.20	10.75	10.47	13.08	34.90			36.15	19.44	13.11	7.98
40	22.79	23.25	23.71	22.78	18.15	13.91	11.24	8.54	8.25	10.54	26.88		34.10	25.45	15.08	10.83	7.13
50	17.28	17.36	17.05	16.36	13.80	11.27	9.41	7.29	7.02	8.95	19.39	28.94	22.55	17.92	12.02	9.08	6.34
75	10.02	9.92	9.55	9.22	8.34	7.43	6.62	5.46	5.27	6.38	9.44	10.15	9.70	8.97	7.26	6.06	4.72
100	6.64	6.56	6.35	6.19	5.79	5.38	4.99	4.35	4.20	4.75	5.74	5.81	5.66	5.43	4.78	4.25	3.58
125	4.79	4.74	4.63	4.55	4.35	4.13	3.93	3.55	3.44	3.67	3.97	3.94	3.86	3.73	3.42	3.15	2.76
150	3.66	3.63	3.58	3.52	3.42	3.29	3.18	2.96	2.86	2.93	2.99	2.91	2.85	2.79	2.61	2.44	2.21
200	2.39	2.38	2.36	2.35	2.30	2.26	2.21	2.13	2.04	2.00	1.93	1.88	1.83	1.80	1.71	1.63	1.53
250	1.71	1.71	1.70	1.70	1.68	1.66	1.63	1.59	1.53	1.47	1.39	1.34	1.32	1.30	1.25	1.20	1.14

Table A7.02 (continuation)

Equivalent dose rate from Pixel + VI, Scenario 0 for T= 10y, t= 30 d

R\Z	0	20	40	50	70	88.5	107	150	200	250	300	325	335	345	365	380	400
0															222.94	22.57	8.86
5														91.71	221.20	21.64	8.80
10														69.35	54.42	19.46	8.61
15	61.54	67.53	106.91											56.93	33.17	17.07	8.33
23	36.77	38.99	50.31	53.30	33.74	20.65	16.78	13.52	13.36	15.71	36.12			41.68	22.13	13.91	7.77
30	27.35	28.59	32.27	31.88	23.03	15.88	12.68	9.87	9.66	11.89	30.18			32.31	17.61	11.90	7.21
40	19.65	20.10	20.69	20.01	16.05	12.30	10.01	7.77	7.55	9.51	23.35		30.68	22.80	13.59	9.77	6.43
50	14.95	15.06	14.89	14.34	12.18	9.98	8.36	6.58	6.37	8.05	16.99	26.14	20.31	16.09	10.81	8.17	5.71
75	8.73	8.66	8.35	8.09	7.34	6.57	5.88	4.89	4.74	5.71	8.38	9.04	8.67	8.03	6.50	5.42	4.24
100	5.81	5.75	5.58	5.44	5.11	4.75	4.42	3.87	3.76	4.23	5.11	5.18	5.06	4.85	4.28	3.81	3.19
125	4.20	4.16	4.07	4.00	3.83	3.66	3.47	3.16	3.07	3.27	3.55	3.50	3.43	3.33	3.06	2.80	2.47
150	3.21	3.20	3.14	3.10	3.01	2.92	2.82	2.62	2.55	2.61	2.67	2.60	2.55	2.49	2.32	2.18	1.97
200	2.11	2.11	2.09	2.07	2.04	2.00	1.96	1.88	1.82	1.78	1.73	1.66	1.63	1.60	1.53	1.46	1.37
250	1.51	1.51	1.51	1.50	1.49	1.46	1.46	1.40	1.36	1.31	1.23	1.20	1.18	1.15	1.10	1.06	1.01

Table A7.02 (continuation)

Equivalent dose rate from Pixel + VI, Scenario 0 for T= 10y, t= 100 d

R\Z	0	20	40	50	70	88.5	107	150	200	250	300	325	335	345	365	380	400
0															208.1	19.50	7.27
5														75.53	206.5	18.63	7.22
10														54.04	48.40	16.59	7.05
15	44.34	48.66	75.23											44.63	28.43	14.36	6.80
23	26.64	28.31	37.13	41.53	26.55	15.46	13.04	11.37	11.34	12.98	26.25			32.77	18.27	11.48	6.30
30	19.93	20.90	24.04	24.33	17.81	12.08	9.84	8.11	8.02	9.59	21.63			25.32	14.29	9.69	5.82
40	14.42	14.81	15.46	15.13	12.28	9.42	7.75	6.26	6.15	7.54	16.90		24.34	17.92	10.87	7.86	5.16
50	11.04	11.15	11.15	10.82	9.28	7.63	6.48	5.25	5.14	6.31	12.60	20.81	16.11	12.70	8.57	6.51	4.56
75	6.53	6.48	6.28	6.11	5.58	5.02	4.53	3.84	3.74	4.44	6.41	7.00	6.74	6.26	5.10	4.27	3.35
100	4.37	4.33	4.21	4.12	3.88	3.64	3.40	3.02	2.95	3.29	3.94	4.01	3.92	3.77	3.35	2.97	2.51
125	3.18	3.15	3.09	3.04	2.92	2.79	2.67	2.45	2.39	2.54	2.74	2.72	2.67	2.59	2.38	2.20	1.94
150	2.44	2.43	2.39	2.37	2.30	2.23	2.17	2.03	1.98	2.02	2.06	2.02	1.98	1.93	1.81	1.70	1.54
200	1.60	1.60	1.59	1.59	1.57	1.54	1.51	1.45	1.41	1.38	1.33	1.29	1.27	1.25	1.18	1.13	1.05
250	1.16	1.16	1.15	1.15	1.15	1.13	1.12	1.09	1.05	1.01	0.97	0.92	0.91	0.89	0.86	0.83	0.79

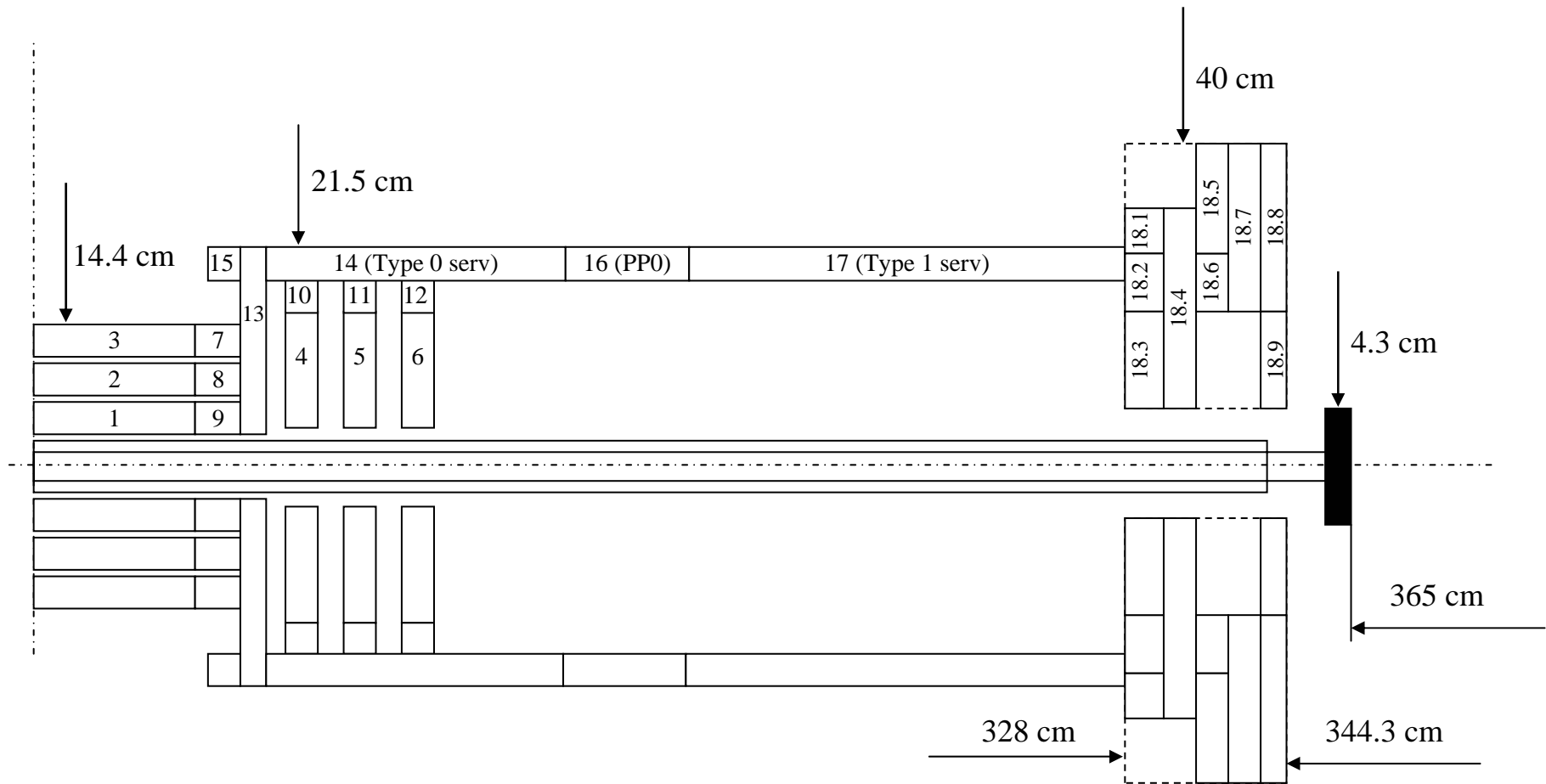

Fig. A7.1 Scenario 1-- Pixel Detector with VI beam pipe section (PST, PP1 cables and connectors removed).

Table A7.1

Equivalent dose rate from Pixel + VI, Scenario 1 for T= 100d, t= 5d

R\Z	0	20	40	50	70	88.5	107	150	200	250	300	325	335	345	365	380	400
0															67.5	7.9	3.2
5														45.6	66.9	7.6	3.2
10														42.0	18.7	7.0	3.1
15	61.2	66.3	103.7											32.0	12.3	6.2	3.0
23	35.3	36.9	44.7	39.6	23.8	16.7	11.8	6.4	5.4	5.4	8.1	18.2		20.8	8.6	5.1	2.8
30	25.6	26.3	27.7	25.3	17.1	12.2	8.9	5.1	4.1	4.1	6.2	11.8		14.7	6.7	4.4	2.6
40	17.8	17.9	17.5	16.2	12.3	9.2	7.0	4.3	3.3	3.3	4.8	7.3	9.7	8.6	5.0	3.5	2.3
50	13.1	13.1	12.4	11.6	9.4	7.4	5.8	3.7	2.8	2.8	3.8	5.0	5.3	5.1	3.8	2.9	2.0
75	7.2	7.1	6.7	6.4	5.6	4.8	4.0	2.9	2.2	2.1	2.4	2.5	2.5	2.5	2.2	1.9	1.5
100	4.6	4.5	4.3	4.1	3.7	3.4	3.0	2.3	1.8	1.6	1.7	1.7	1.6	1.6	1.5	1.3	1.1
125	3.1	3.1	3.0	2.9	2.7	2.5	2.3	1.9	1.5	1.4	1.3	1.2	1.2	1.2	1.1	1.0	0.91
150	2.3	2.3	2.2	2.2	2.1	1.9	1.8	1.5	1.3	1.1	1.0	1.0	1.0	0.94	0.87	0.83	0.75
200	1.4	1.4	1.4	1.4	1.3	1.3	1.2	1.1	0.94	0.83	0.74	0.70	0.68	0.67	0.63	0.60	0.55
250	1.0	1.0	0.94	0.93	0.91	0.89	0.87	0.80	0.72	0.65	0.58	0.54	0.52	0.51	0.48	0.46	0.44

Table A7.1 (continuation)

Equivalent dose rate from Pixel + VI, Scenario 1 for T= 100d, t= 7 d

R\Z	0	20	40	50	70	88.5	107	150	200	250	300	325	335	345	365	380	400
0															62.9	7.3	3.0
5														41.9	62.4	7.1	2.9
10														38.4	17.4	6.4	2.9
15	55.0	59.7	95.1											29.3	11.4	5.7	2.8
23	31.9	33.4	40.7	36.3	21.8	15.3	10.9	6.0	5.0	5.0	7.5	16.7		19.1	7.9	4.7	2.6
30	23.1	23.9	25.3	23.1	15.7	11.2	8.2	4.7	3.8	3.8	5.8	10.8		13.5	6.2	4.0	2.4
40	16.1	16.3	15.9	14.8	11.2	8.4	6.4	3.9	3.1	3.0	4.4	6.7	8.8	7.9	4.6	3.3	2.1
50	11.9	11.9	11.3	10.6	8.6	6.8	5.3	3.4	2.6	2.6	3.5	4.5	4.8	4.7	3.5	2.7	1.9
75	6.6	6.5	6.1	5.8	5.1	4.4	3.7	2.6	2.0	1.9	2.2	2.3	2.3	2.3	2.0	1.7	1.4
100	4.1	4.1	3.9	3.8	3.4	3.1	2.7	2.1	1.7	1.5	1.5	1.5	1.5	1.5	1.3	1.2	1.1
125	2.9	2.8	2.7	2.7	2.5	2.3	2.1	1.7	1.4	1.2	1.2	1.1	1.1	1.1	1.0	0.93	0.84
150	2.1	2.1	2.0	2.0	1.9	1.8	1.7	1.4	1.2	1.0	1.0	0.90	0.88	0.86	0.81	0.77	0.69
200	1.3	1.3	1.3	1.2	1.2	1.2	1.1	1.0	0.87	0.76	0.69	0.65	0.63	0.62	0.57	0.55	0.51
250	0.86	0.86	0.85	0.84	0.83	0.81	0.79	0.73	0.65	0.58	0.53	0.49	0.48	0.47	0.44	0.43	0.41

Table A7.1 (continuation)

Equivalent dose rate from Pixel + VI, Scenario 1 for T= 100d, t= 15 d

R\Z	0	20	40	50	70	88.5	107	150	200	250	300	325	335	345	365	380	400
0															56.8	6.3	2.5
5														35.0	56.4	6.1	2.5
10														31.2	15.2	5.5	2.4
15	42.5	46.4	76.3											23.9	9.7	4.9	2.3
23	24.8	26.1	32.4	29.6	18.0	12.4	8.9	5.2	4.4	4.4	6.4	13.8		15.7	6.6	4.0	2.2
30	18.1	18.8	20.2	18.7	12.8	9.1	6.7	4.0	3.3	3.3	4.9	8.9		11.1	5.2	3.4	2.0
40	12.7	12.8	12.7	11.9	9.1	6.9	5.3	3.3	2.6	2.6	3.7	5.6	7.2	6.5	3.8	2.7	1.8
50	9.4	9.4	9.0	8.5	6.9	5.5	4.4	2.8	2.2	2.2	2.9	3.8	4.0	3.9	2.9	2.2	1.6
75	5.2	5.1	4.9	4.7	4.1	3.5	3.0	2.2	1.7	1.6	1.8	1.9	1.9	1.9	1.6	1.4	1.1
100	3.3	3.3	3.1	3.0	2.8	2.5	2.2	1.7	1.4	1.3	1.3	1.3	1.3	1.2	1.1	1.0	0.88
125	2.3	2.3	2.2	2.1	2.0	1.9	1.7	1.4	1.2	1.0	1.0	0.94	0.92	0.90	0.84	0.78	0.68
150	1.7	1.7	1.6	1.6	1.5	1.4	1.4	1.2	1.0	0.9	0.79	0.76	0.73	0.71	0.67	0.62	0.57
200	1.0	1.0	1.0	1.0	1.0	0.93	0.90	0.80	0.71	0.63	0.57	0.53	0.51	0.50	0.47	0.45	0.42
250	0.70	0.70	0.70	0.69	0.68	0.66	0.64	0.59	0.53	0.48	0.43	0.41	0.40	0.39	0.37	0.36	0.33

Table A7.1 (continuation)

Equivalent dose rate from Pixel + VI, Scenario 1 for T= 100d, t= 30 d

R\Z	0	20	40	50	70	88.5	107	150	200	250	300	325	335	345	365	380	400
0															52.0	5.5	2.1
5														29.0	51.6	5.2	2.1
10														24.9	13.3	4.7	2.0
15	32.6	35.7	60.1											19.2	8.3	4.1	2.0
23	19.1	20.2	25.4	23.9	14.6	9.8	7.2	4.4	3.8	3.8	5.4	11.2		12.7	5.6	3.4	1.8
30	14.0	14.6	15.9	14.9	10.3	7.3	5.4	3.4	2.8	2.8	4.1	7.3		9.0	4.3	2.8	1.7
40	9.9	10.0	10.0	9.4	7.3	5.5	4.2	2.7	2.2	2.2	3.1	4.6	5.9	5.3	3.2	2.3	1.5
50	7.4	7.4	7.1	6.7	5.5	4.4	3.5	2.3	1.9	1.8	2.4	3.1	3.3	3.2	2.4	1.8	1.3
75	4.1	4.1	3.9	3.7	3.3	2.8	2.4	1.8	1.4	1.3	1.5	1.6	1.6	1.5	1.4	1.2	1.0
100	2.6	2.6	2.5	2.4	2.2	2.0	1.8	1.4	1.1	1.1	1.1	1.0	1.0	1.0	0.92	0.83	0.72
125	1.8	1.8	1.8	1.7	1.6	1.5	1.4	1.1	0.94	0.85	0.81	0.78	0.76	0.74	0.69	0.63	0.56
150	1.3	1.3	1.3	1.3	1.2	1.1	1.1	0.91	0.79	0.70	0.64	0.62	0.61	0.58	0.54	0.51	0.46
200	0.84	0.83	0.81	0.80	0.78	0.76	0.73	0.65	0.57	0.51	0.47	0.43	0.42	0.41	0.39	0.36	0.34
250	0.56	0.56	0.55	0.55	0.54	0.53	0.52	0.47	0.44	0.40	0.34	0.33	0.32	0.31	0.30	0.29	0.27

Table A7.1 (continuation)

Equivalent dose rate from Pixel + VI, Scenario 1 for T= 100d, t= 100 d

R\Z	0	20	40	50	70	88.5	107	150	200	250	300	325	335	345	365	380	400
0															45.5	4.2	1.5
5														19.5	45.1	4.0	1.5
10														15.2	10.6	3.5	1.4
15	18.6	20.4	33.9											11.9	6.2	3.0	1.4
23	10.9	11.6	14.8	14.7	9.1	5.7	4.4	3.0	2.7	2.8	3.8	7.4		8.0	3.9	2.4	1.3
30	8.1	8.4	9.3	9.0	6.3	4.3	3.3	2.3	2.0	2.0	2.8	4.8		5.7	2.9	2.0	1.2
40	5.7	5.8	5.9	5.6	4.4	3.3	2.6	1.8	1.5	1.5	2.1	3.0	3.7	3.4	2.1	1.5	1.0
50	4.3	4.3	4.2	4.0	3.3	2.6	2.1	1.5	1.3	1.3	1.6	2.0	2.2	2.1	1.6	1.2	0.87
75	2.4	2.4	2.3	2.2	1.9	1.7	1.5	1.1	0.9	0.9	1.0	1.1	1.1	1.0	0.90	0.78	0.63
100	1.6	1.5	1.5	1.4	1.3	1.2	1.1	0.86	0.73	0.68	0.69	0.69	0.69	0.66	0.60	0.54	0.47
125	1.1	1.1	1.0	1.0	1.0	0.90	0.83	0.69	0.60	0.55	0.53	0.50	0.49	0.48	0.44	0.42	0.37
150	0.80	0.80	0.78	0.77	0.73	0.69	0.66	0.57	0.50	0.45	0.41	0.39	0.38	0.37	0.35	0.33	0.31
200	0.50	0.50	0.49	0.49	0.47	0.45	0.45	0.40	0.36	0.33	0.29	0.27	0.27	0.26	0.25	0.24	0.22
250	0.34	0.34	0.34	0.34	0.33	0.33	0.32	0.30	0.27	0.24	0.22	0.21	0.20	0.20	0.19	0.18	0.18

Table A7.2

Equivalent dose rate from Pixel + VI, Scenario 1 for T= 10y, t= 5 d

R\Z	0	20	40	50	70	88.5	107	150	200	250	300	325	335	345	365	380	400
0															235.2	21.3	7.5
5														99.1	233.4	20.3	7.4
10														77.3	54.7	18.0	7.2
15	91.0	98.8	152.5											60.4	31.9	15.4	7.0
23	53.3	56.0	70.1	69.6	43.1	27.4	21.2	14.9	13.6	13.9	19.1	38.1		40.3	19.9	12.1	6.4
30	39.0	40.5	44.3	42.5	29.8	20.6	15.8	11.0	9.7	9.9	14.0	24.4		28.5	15.0	9.9	5.8
40	27.5	28.0	28.1	26.7	20.9	15.8	12.4	8.7	7.4	7.5	10.4	15.1	18.9	17.1	10.7	7.8	5.1
50	20.6	20.6	20.0	19.1	15.8	12.7	10.3	7.3	6.2	6.2	8.2	10.3	10.9	10.5	8.0	6.3	4.4
75	11.6	11.5	10.9	10.5	9.3	8.2	7.1	5.4	4.5	4.4	5.0	5.3	5.3	5.1	4.5	3.9	3.2
100	7.5	7.4	7.1	6.9	6.3	5.8	5.2	4.2	3.6	3.4	3.5	3.4	3.4	3.3	3.0	2.8	2.4
125	5.2	5.2	5.0	4.9	4.6	4.3	4.0	3.4	2.9	2.7	2.6	2.5	2.5	2.4	2.2	2.1	1.9
150	3.9	3.9	3.8	3.7	3.5	3.4	3.2	2.8	2.4	2.2	2.1	2.0	1.9	1.9	1.8	1.7	1.5
200	2.4	2.4	2.4	2.4	2.3	2.2	2.2	2.0	1.8	1.6	1.5	1.4	1.4	1.3	1.2	1.2	1.1
250	1.7	1.7	1.7	1.7	1.6	1.6	1.6	1.4	1.3	1.2	1.1	1.0	1.0	0.99	0.94	0.91	0.85

Table A7.2 (continuation)

Equivalent dose rate from Pixel + VI, Scenario 1 for T= 10y, t= 7 d

R\Z	0	20	40	50	70	88.5	107	150	200	250	300	325	335	345	365	380	400
0															229.3	20.7	7.2
5														95.4	227.5	19.7	7.2
10														73.6	53.1	17.4	7.0
15	84.8	92.1	143.7											57.6	30.8	14.9	6.7
23	49.8	52.4	66.1	66.2	41.1	26.0	20.2	14.5	13.2	13.5	18.5	36.5		38.5	19.1	11.6	6.2
30	36.5	38.0	41.8	40.2	28.4	19.6	15.1	10.6	9.4	9.6	13.5	23.3		27.2	14.4	9.6	5.6
40	25.8	26.3	26.5	25.3	19.8	15.0	11.8	8.3	7.1	7.3	10.1	14.5	18.1	16.3	10.3	7.5	4.9
50	19.4	19.4	18.9	18.0	15.0	12.0	9.8	7.0	5.9	6.0	7.9	9.9	10.4	10.0	7.7	6.0	4.2
75	10.9	10.8	10.3	9.9	8.9	7.7	6.7	5.1	4.3	4.2	4.8	5.1	5.1	4.9	4.3	3.8	3.0
100	7.1	7.0	6.7	6.5	6.0	5.5	5.0	4.0	3.4	3.2	3.3	3.3	3.3	3.2	2.9	2.6	2.3
125	5.0	4.9	4.8	4.7	4.4	4.1	3.8	3.2	2.8	2.6	2.5	2.4	2.4	2.3	2.1	2.0	1.8
150	3.7	3.7	3.6	3.5	3.4	3.2	3.0	2.6	2.3	2.1	2.0	1.9	1.9	1.8	1.7	1.6	1.5
200	2.3	2.3	2.3	2.2	2.2	2.1	2.0	1.9	1.7	1.5	1.4	1.3	1.3	1.3	1.2	1.1	1.1
250	1.6	1.6	1.6	1.6	1.5	1.5	1.5	1.4	1.3	1.2	1.0	1.0	0.97	0.94	0.90	0.87	0.82

Table A7.2 (continuation)

Equivalent dose rate from Pixel + VI, Scenario 1 for T= 10y, t= 15 d

R\Z	0	20	40	50	70	88.5	107	150	200	250	300	325	335	345	365	380	400
0															225.4	19.7	6.8
5														88.6	223.6	18.8	6.7
10														66.3	51.2	16.5	6.5
15	71.8	78.3	124.0											52.1	29.3	14.1	6.3
23	42.4	44.9	57.4	59.1	37.0	22.9	18.1	13.6	12.6	12.8	17.3	33.5		35.0	17.9	10.9	5.7
30	31.3	32.6	36.4	35.5	25.3	17.4	13.5	9.8	8.8	9.0	12.6	21.4		24.7	13.4	8.9	5.2
40	22.3	22.7	23.2	22.2	17.6	13.3	10.6	7.6	6.7	6.8	9.3	13.3	16.4	14.9	9.5	7.0	4.5
50	16.8	16.8	16.5	15.8	13.2	10.7	8.8	6.4	5.5	5.6	7.3	9.1	9.6	9.2	7.1	5.6	3.9
75	9.5	9.4	9.1	8.7	7.8	6.9	6.0	4.6	4.0	3.9	4.4	4.7	4.7	4.5	4.0	3.5	2.8
100	6.2	6.1	5.9	5.7	5.3	4.9	4.4	3.6	3.1	3.0	3.1	3.0	3.0	2.9	2.7	2.4	2.1
125	4.4	4.3	4.2	4.1	3.9	3.6	3.4	2.9	2.5	2.4	2.3	2.2	2.2	2.1	2.0	1.8	1.6
150	3.3	3.2	3.2	3.1	3.0	2.8	2.7	2.4	2.1	1.9	1.8	1.7	1.7	1.7	1.6	1.5	1.3
200	2.0	2.0	2.0	2.0	1.9	1.9	1.8	1.7	1.5	1.4	1.3	1.2	1.2	1.1	1.1	1.0	0.97
250	1.4	1.4	1.4	1.4	1.4	1.3	1.3	1.2	1.1	1.0	0.94	0.90	0.88	0.86	0.82	0.78	0.75

Table A7.2 (continuation)

Equivalent dose rate from Pixel + VI, Scenario 1 for T= 10y, t= 30 d

R\Z	0	20	40	50	70	88.5	107	150	200	250	300	325	335	345	365	380	400
0															217.2	18.6	6.3
5														81.6	215.5	17.7	6.2
10														59.3	48.7	15.5	6.1
15	61.1	66.6	106.3											46.8	27.5	13.2	5.8
23	36.2	38.5	49.8	52.8	33.2	20.1	16.2	12.7	11.9	12.1	16.2	30.6		31.6	16.6	10.2	5.3
30	26.9	28.1	31.8	31.4	22.5	15.4	12.1	9.1	8.3	8.5	11.7	19.5		22.3	12.3	8.3	4.8
40	19.2	19.6	20.2	19.5	15.6	11.8	9.4	7.0	6.2	6.4	8.6	12.2	14.9	13.5	8.8	6.4	4.2
50	14.5	14.6	14.4	13.9	11.7	9.5	7.8	5.8	5.1	5.2	6.7	8.3	8.7	8.4	6.5	5.1	3.6
75	8.3	8.3	7.9	7.7	6.9	6.1	5.4	4.2	3.6	3.6	4.1	4.3	4.3	4.2	3.7	3.2	2.6
100	5.4	5.4	5.2	5.0	4.7	4.3	3.9	3.2	2.8	2.7	2.8	2.8	2.7	2.7	2.4	2.2	1.9
125	3.8	3.8	3.7	3.6	3.4	3.2	3.0	2.6	2.3	2.2	2.1	2.0	2.0	1.9	1.8	1.7	1.5
150	2.9	2.9	2.8	2.7	2.6	2.5	2.4	2.1	1.9	1.8	1.7	1.6	1.6	1.5	1.4	1.3	1.2
200	1.8	1.8	1.8	1.8	1.7	1.7	1.6	1.5	1.4	1.3	1.2	1.1	1.1	1.0	0.98	0.94	0.88
250	1.3	1.3	1.3	1.2	1.2	1.2	1.2	1.1	1.0	0.94	0.85	0.82	0.80	0.78	0.73	0.71	0.67

Table A7.2 (continuation)

Equivalent dose rate from Pixel + VI, Scenario 1 for T= 10y, t= 100 d

R\Z	0	20	40	50	70	88.5	107	150	200	250	300	325	335	345	365	380	400
0															204.0	16.7	5.4
5														68.5	202.4	15.8	5.4
10														47.0	44.3	13.8	5.2
15	44.0	48.0	74.8											37.5	24.4	11.6	5.0
23	26.3	27.9	36.7	41.2	26.2	15.1	12.6	10.8	10.3	10.6	13.9	25.5		25.6	14.3	8.8	4.5
30	19.6	20.6	23.7	24.0	17.5	11.7	9.4	7.6	7.1	7.3	9.9	16.2		18.1	10.5	7.1	4.1
40	14.1	14.5	15.1	14.8	11.9	9.1	7.4	5.7	5.2	5.4	7.2	10.1	12.1	11.0	7.4	5.4	3.5
50	10.7	10.8	10.8	10.5	8.9	7.3	6.1	4.7	4.3	4.4	5.6	6.9	7.2	7.0	5.5	4.3	3.1
75	6.2	6.2	6.0	5.8	5.3	4.7	4.2	3.4	3.0	3.0	3.4	3.6	3.6	3.5	3.1	2.7	2.2
100	4.1	4.1	3.9	3.8	3.6	3.3	3.1	2.6	2.3	2.2	2.3	2.3	2.3	2.2	2.0	1.8	1.6
125	2.9	2.9	2.8	2.8	2.6	2.5	2.4	2.1	1.9	1.8	1.7	1.7	1.6	1.6	1.5	1.4	1.2
150	2.2	2.2	2.2	2.1	2.0	2.0	1.9	1.7	1.5	1.4	1.4	1.3	1.3	1.2	1.2	1.1	1.0
200	1.4	1.4	1.4	1.4	1.4	1.3	1.3	1.2	1.1	1.0	0.92	0.89	0.87	0.85	0.80	0.76	0.71
250	0.98	0.98	0.97	0.97	0.96	0.94	0.92	0.87	0.82	0.75	0.70	0.65	0.64	0.63	0.60	0.58	0.55

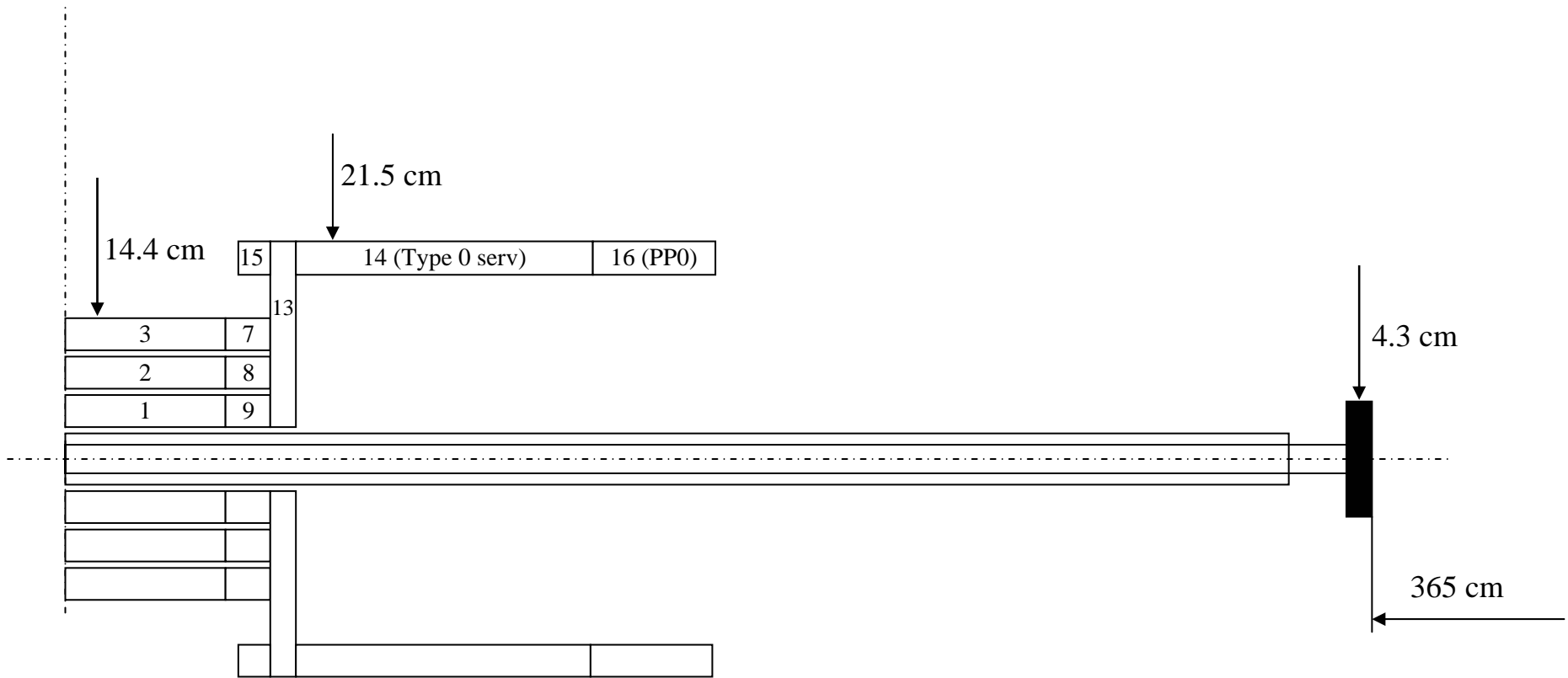

Fig. A7.2 Scenario 2 -- the Pixel Detector with VI beam pipe section (PST, PP1, Type 1 services, and Disks removed).

Table A7.3

Equivalent dose rate from Pixel + VI, Scenario 2 for T= 100d, t= 5d

R\Z	0	20	40	50	70	88.5	107	150	200	250	300	325	335	345	365	380	400
0															59.9	4.0	1.2
5				89.4	25.9	16.8	11.7	5.8	4.3	3.8	3.9	4.4	5.6	14.3	59.4	3.8	1.2
10				75.8	24.0	15.6	10.3	4.1	2.7	2.2	2.1	2.7	3.6	6.1	11.5	3.2	1.1
15	59.7	64.3		58.2	24.2	16.6	10.6	3.6	2.2	1.7	1.7	2.1	2.7	3.9	5.6	2.6	1.1
23	33.9	35.1	39.1	34.7	20.5	14.7	9.4	3.2	1.9	1.4	1.3	1.6	1.9	2.4	2.7	1.8	1.0
30	24.3	24.8	24.9	22.3	14.8	10.5	7.1	3.0	1.7	1.3	1.2	1.4	1.5	1.7	1.8	1.4	0.9
40	16.6	16.6	15.7	14.4	10.7	7.8	5.6	2.7	1.6	1.1	1.0	1.1	1.2	1.3	1.2	1.0	0.74
50	12.1	12.0	11.1	10.3	8.1	6.2	4.7	2.5	1.5	1.1	0.91	0.95	0.96	0.98	0.94	0.82	0.65
75	6.5	6.3	5.9	5.6	4.8	4.0	3.3	2.0	1.3	0.92	0.74	0.71	0.70	0.68	0.62	0.57	0.51
100	4.0	3.9	3.7	3.5	3.2	2.8	2.4	1.7	1.1	0.81	0.64	0.58	0.57	0.54	0.50	0.47	0.42
125	2.7	2.6	2.5	2.4	2.2	2.0	1.8	1.4	1.0	0.72	0.57	0.52	0.49	0.47	0.44	0.40	0.37
150	1.9	1.9	1.8	1.8	1.7	1.6	1.4	1.1	0.83	0.63	0.51	0.45	0.44	0.42	0.38	0.36	0.33
200	1.1	1.1	1.1	1.1	1.0	0.98	0.92	0.78	0.62	0.51	0.41	0.37	0.36	0.34	0.32	0.31	0.28
250	0.74	0.74	0.73	0.72	0.70	0.68	0.64	0.57	0.49	0.41	0.34	0.31	0.30	0.29	0.27	0.26	0.24

Table A7.3 (continuation)

Equivalent dose rate from Pixel + VI, Scenario 2 for T= 100d, t= 7 d

R\Z	0	20	40	50	70	88.5	107	150	200	250	300	325	335	345	365	380	400
0															55.9	3.8	1.1
5				82.3	23.9	15.6	10.9	5.5	4.2	3.7	3.7	4.2	5.3	13.4	55.5	3.5	1.1
10				69.8	22.1	14.4	9.4	3.8	2.5	2.1	2.0	2.5	3.4	5.7	10.7	3.0	1.1
15	53.7	57.9		53.6	22.3	15.3	9.8	3.3	2.1	1.6	1.6	2.0	2.6	3.7	5.2	2.4	1.0
23	30.6	31.8	35.8	31.9	18.9	13.5	8.6	2.9	1.7	1.3	1.3	1.5	1.8	2.2	2.6	1.7	0.89
30	21.9	22.4	22.7	20.4	13.6	9.6	6.5	2.7	1.6	1.2	1.1	1.3	1.4	1.6	1.7	1.3	0.81
40	15.0	15.1	14.4	13.1	9.8	7.2	5.2	2.5	1.5	1.1	1.0	1.0	1.1	1.2	1.1	1.0	0.69
50	11.0	10.9	10.2	9.4	7.4	5.7	4.3	2.3	1.4	1.0	0.84	0.88	0.89	0.90	0.87	0.76	0.61
75	5.9	5.8	5.4	5.1	4.4	3.6	3.0	1.9	1.2	0.84	0.69	0.66	0.64	0.62	0.58	0.54	0.46
100	3.6	3.6	3.4	3.2	2.9	2.5	2.2	1.5	1.0	0.75	0.60	0.55	0.52	0.50	0.46	0.43	0.38
125	2.4	2.4	2.3	2.2	2.0	1.9	1.7	1.2	0.88	0.65	0.52	0.46	0.44	0.43	0.40	0.37	0.34
150	1.8	1.7	1.7	1.6	1.5	1.4	1.3	1.0	0.77	0.58	0.47	0.41	0.40	0.38	0.36	0.34	0.31
200	1.0	1.0	0.99	0.98	0.94	0.90	0.84	0.71	0.57	0.47	0.37	0.34	0.33	0.32	0.30	0.28	0.26
250	0.67	0.67	0.66	0.65	0.63	0.61	0.58	0.51	0.44	0.36	0.31	0.28	0.27	0.27	0.25	0.24	0.23

Table A7.3 (continuation)

Equivalent dose rate from Pixel + VI, Scenario 2 for T= 100d, t= 15 d

R\Z	0	20	40	50	70	88.5	107	150	200	250	300	325	335	345	365	380	400
0															51.1	3.4	0.98
5				67.2	19.8	12.8	9.0	4.7	3.6	3.2	3.3	3.8	4.8	12.3	50.8	3.2	0.97
10				57.1	18.2	11.7	7.7	3.2	2.1	1.8	1.8	2.3	3.0	5.2	9.8	2.7	0.93
15	41.5	45.0		44.0	18.4	12.3	7.9	2.7	1.7	1.4	1.4	1.8	2.3	3.3	4.7	2.2	0.88
23	23.8	24.9	28.7	26.2	15.6	10.9	7.0	2.4	1.5	1.1	1.1	1.3	1.6	2.0	2.3	1.5	0.79
30	17.1	17.6	18.2	16.5	11.1	7.8	5.3	2.2	1.3	0.99	0.94	1.1	1.3	1.5	1.5	1.2	0.71
40	11.8	11.9	11.5	10.6	7.9	5.8	4.2	2.0	1.2	0.88	0.81	0.9	1.0	1.0	1.0	0.85	0.61
50	8.7	8.6	8.1	7.5	6.0	4.6	3.5	1.9	1.1	0.81	0.72	0.8	0.8	0.8	0.8	0.7	0.52
75	4.7	4.6	4.3	4.1	3.5	2.9	2.4	1.5	0.95	0.70	0.58	0.56	0.54	0.53	0.49	0.45	0.39
100	2.9	2.8	2.7	2.6	2.3	2.0	1.8	1.2	0.82	0.60	0.49	0.45	0.43	0.42	0.39	0.36	0.33
125	1.9	1.9	1.8	1.8	1.6	1.5	1.3	0.99	0.72	0.53	0.43	0.38	0.37	0.35	0.33	0.31	0.28
150	1.4	1.4	1.3	1.3	1.2	1.1	1.0	0.82	0.62	0.47	0.39	0.35	0.32	0.31	0.29	0.28	0.25
200	0.82	0.81	0.79	0.78	0.75	0.71	0.67	0.57	0.46	0.39	0.31	0.27	0.27	0.26	0.24	0.23	0.22
250	0.54	0.54	0.53	0.53	0.50	0.49	0.47	0.42	0.36	0.30	0.25	0.23	0.23	0.22	0.21	0.20	0.18

Table A7.3 (continuation)

Equivalent dose rate from Pixel + VI, Scenario 2 for T= 100d, t= 30 d

R\Z	0	20	40	50	70	88.5	107	150	200	250	300	325	335	345	365	380	400
0															47.5	3.1	0.87
5				53.8	15.9	10.2	7.2	3.8	2.9	2.6	2.7	3.2	4.2	11.3	47.2	2.9	0.86
10				45.9	14.7	9.3	6.1	2.6	1.7	1.5	1.5	1.9	2.7	4.7	9.1	2.5	0.83
15	31.8	34.6		35.6	14.9	9.7	6.2	2.2	1.4	1.1	1.2	1.5	2.0	3.0	4.3	2.0	0.78
23	18.3	19.2	22.7	21.2	12.6	8.6	5.5	1.9	1.2	0.91	0.90	1.2	1.4	1.8	2.1	1.4	0.69
30	13.2	13.7	14.4	13.2	8.9	6.2	4.2	1.8	1.1	0.80	0.79	1.0	1.1	1.3	1.4	1.0	0.62
40	9.2	9.3	9.0	8.4	6.3	4.6	3.3	1.6	0.95	0.72	0.68	0.77	0.83	0.89	0.89	0.75	0.52
50	6.8	6.7	6.4	6.0	4.8	3.7	2.8	1.5	0.89	0.66	0.60	0.63	0.66	0.68	0.66	0.58	0.45
75	3.7	3.6	3.4	3.2	2.8	2.3	1.9	1.2	0.76	0.56	0.47	0.45	0.45	0.44	0.42	0.38	0.34
100	2.3	2.2	2.1	2.0	1.8	1.6	1.4	0.96	0.65	0.49	0.40	0.36	0.35	0.34	0.32	0.30	0.27
125	1.5	1.5	1.5	1.4	1.3	1.2	1.1	0.78	0.57	0.43	0.35	0.31	0.30	0.29	0.27	0.25	0.23
150	1.1	1.1	1.1	1.0	0.96	0.89	0.82	0.65	0.50	0.38	0.30	0.28	0.27	0.25	0.24	0.23	0.20
200	0.65	0.65	0.64	0.63	0.59	0.57	0.54	0.46	0.37	0.31	0.25	0.23	0.22	0.21	0.20	0.18	0.17
250	0.43	0.41	0.41	0.40	0.39	0.38	0.37	0.33	0.29	0.24	0.20	0.18	0.18	0.17	0.16	0.16	0.15

Table A7.3 (continuation)

Equivalent dose rate from Pixel + VI, Scenario 2 for T= 100d, t= 100 d

R\Z	0	20	40	50	70	88.5	107	150	200	250	300	325	335	345	365	380	400
0															42.7	2.7	0.71
5				32.0	9.3	5.6	3.7	1.8	1.3	1.2	1.3	1.8	2.7	9.4	42.4	2.5	0.70
10				27.6	8.8	5.2	3.3	1.3	0.85	0.71	0.79	1.3	1.9	3.9	8.0	2.1	0.67
15	18.1	19.7		21.8	9.2	5.5	3.4	1.2	0.71	0.58	0.65	1.0	1.5	2.5	3.8	1.7	0.63
23	10.4	11.0	13.2	13.1	7.8	4.9	3.0	1.1	0.62	0.49	0.54	0.82	1.1	1.4	1.8	1.1	0.56
30	7.6	7.8	8.4	7.9	5.4	3.6	2.4	0.99	0.57	0.45	0.48	0.67	0.83	1.0	1.1	0.84	0.49
40	5.3	5.3	5.3	4.9	3.7	2.7	1.9	0.91	0.53	0.40	0.42	0.53	0.61	0.68	0.71	0.59	0.40
50	3.9	3.9	3.7	3.5	2.8	2.1	1.6	0.84	0.50	0.38	0.38	0.43	0.47	0.50	0.50	0.45	0.34
75	2.1	2.1	2.0	1.9	1.6	1.3	1.1	0.69	0.43	0.33	0.29	0.30	0.30	0.30	0.29	0.27	0.23
100	1.3	1.3	1.2	1.2	1.1	0.93	0.80	0.56	0.39	0.29	0.24	0.23	0.24	0.23	0.22	0.20	0.18
125	0.89	0.88	0.84	0.82	0.75	0.68	0.61	0.45	0.33	0.26	0.21	0.20	0.19	0.18	0.17	0.17	0.15
150	0.63	0.63	0.61	0.59	0.56	0.51	0.47	0.38	0.29	0.23	0.19	0.17	0.16	0.16	0.15	0.14	0.14
200	0.37	0.37	0.36	0.36	0.34	0.33	0.31	0.27	0.22	0.18	0.15	0.14	0.13	0.13	0.12	0.12	0.11
250	0.25	0.25	0.24	0.24	0.24	0.23	0.22	0.19	0.16	0.14	0.12	0.11	0.11	0.11	0.10	0.10	0.09

Table A7.4

Equivalent dose rate from Pixel + VI, Scenario 2 for T= 10 y, t= 5d

R\Z	0	20	40	50	70	88.5	107	150	200	250	300	325	335	345	365	380	400
0															221.3	14.0	3.6
5				149.5	43.0	25.8	17.0	7.9	5.6	4.8	5.5	8.0	12.9	47.3	219.6	13.1	3.5
10				128.4	41.5	24.6	15.5	5.9	3.7	3.1	3.6	5.9	9.6	19.6	41.4	10.9	3.4
15	88.3	95.3		101.1	43.4	26.0	16.1	5.4	3.2	2.6	3.0	5.0	7.5	12.4	19.4	8.6	3.2
23	50.7	52.8	61.8	61.5	37.0	23.1	14.5	4.9	2.8	2.2	2.6	4.0	5.3	7.3	9.0	5.8	2.8
30	36.6	37.6	39.6	37.3	25.4	16.9	11.2	4.6	2.7	2.0	2.3	3.3	4.1	5.0	5.7	4.3	2.4
40	25.3	25.5	25.0	23.4	17.7	12.7	9.0	4.3	2.5	1.9	2.0	2.6	3.0	3.4	3.5	2.9	2.0
50	18.6	18.5	17.6	16.5	13.2	10.1	7.5	3.9	2.4	1.8	1.8	2.2	2.3	2.5	2.5	2.2	1.7
75	10.1	9.9	9.3	8.8	7.6	6.4	5.2	3.2	2.1	1.5	1.4	1.5	1.5	1.5	1.4	1.3	1.2
100	6.3	6.1	5.8	5.6	5.0	4.4	3.8	2.6	1.8	1.4	1.2	1.1	1.1	1.1	1.0	0.99	0.88
125	4.2	4.2	4.0	3.9	3.6	3.2	2.9	2.2	1.6	1.2	1.0	0.96	0.92	0.90	0.84	0.80	0.73
150	3.1	3.0	2.9	2.8	2.7	2.5	2.3	1.8	1.4	1.1	0.90	0.82	0.80	0.78	0.73	0.69	0.62
200	1.8	1.8	1.8	1.7	1.6	1.6	1.5	1.3	1.0	0.85	0.71	0.66	0.64	0.62	0.56	0.54	0.50
250	1.2	1.2	1.2	1.2	1.1	1.1	1.0	0.92	0.80	0.67	0.58	0.54	0.52	0.50	0.47	0.45	0.42

Table A7.4 (continuation)

Equivalent dose rate from Pixel + VI, Scenario 2 for T= 10 y, t= 7 d

R\Z	0	20	40	50	70	88.5	107	150	200	250	300	325	335	345	365	380	400
0															216.1	13.7	3.5
5				142.2	41.0	24.5	16.2	7.5	5.4	4.7	5.3	7.8	12.6	46.5	214.4	12.8	3.5
10				122.2	39.5	23.3	14.7	5.7	3.6	2.9	3.4	5.8	9.4	19.2	40.5	10.6	3.3
15	82.2	88.8		96.4	41.4	24.6	15.3	5.1	3.1	2.5	2.9	4.9	7.4	12.1	18.9	8.4	3.1
23	47.3	49.4	58.3	58.6	35.3	21.9	13.7	4.6	2.7	2.1	2.5	3.9	5.2	7.1	8.8	5.7	2.7
30	34.2	35.2	37.3	35.4	24.1	16.0	10.6	4.4	2.5	1.9	2.2	3.2	4.0	4.9	5.6	4.1	2.4
40	23.7	23.9	23.6	22.1	16.7	12.0	8.5	4.0	2.4	1.8	2.0	2.6	2.9	3.3	3.4	2.9	2.0
50	17.5	17.4	16.6	15.6	12.5	9.5	7.1	3.7	2.2	1.7	1.8	2.1	2.3	2.4	2.4	2.1	1.6
75	9.5	9.3	8.8	8.3	7.2	6.0	4.9	3.1	2.0	1.5	1.4	1.4	1.4	1.4	1.4	1.3	1.1
100	5.9	5.8	5.5	5.3	4.7	4.2	3.6	2.5	1.7	1.3	1.1	1.1	1.1	1.1	1.0	0.95	0.85
125	4.0	3.9	3.8	3.7	3.4	3.1	2.7	2.1	1.5	1.2	1.0	0.91	0.89	0.86	0.82	0.77	0.70
150	2.9	2.8	2.8	2.7	2.5	2.3	2.1	1.7	1.3	1.0	0.86	0.79	0.76	0.74	0.69	0.65	0.60
200	1.7	1.7	1.6	1.6	1.6	1.5	1.4	1.2	1.0	0.81	0.67	0.62	0.60	0.58	0.54	0.52	0.48
250	1.1	1.1	1.1	1.1	1.1	1.0	0.99	0.88	0.76	0.64	0.55	0.50	0.48	0.47	0.44	0.43	0.41

Table A7.4 (continuation)

Equivalent dose rate from Pixel + VI, Scenario 2 for T= 10 y, t= 15d

R\Z	0	20	40	50	70	88.5	107	150	200	250	300	325	335	345	365	380	400
0															213.5	13.5	3.4
5				126.3	36.6	21.7	14.2	6.7	4.8	4.2	4.9	7.4	12.2	45.7	211.9	12.6	3.4
10				108.8	35.4	20.5	12.9	5.0	3.2	2.7	3.2	5.5	9.1	18.9	39.9	10.5	3.2
15	69.5	75.4		86.3	37.3	21.6	13.3	4.5	2.7	2.2	2.7	4.7	7.1	11.9	18.6	8.2	3.0
23	40.2	42.2	50.9	52.5	31.8	19.1	11.9	4.1	2.4	1.9	2.3	3.7	5.0	6.9	8.6	5.5	2.6
30	29.2	30.2	32.6	31.3	21.5	14.0	9.3	3.8	2.2	1.8	2.1	3.1	3.9	4.8	5.4	4.0	2.3
40	20.4	20.6	20.5	19.4	14.8	10.5	7.4	3.6	2.1	1.6	1.8	2.4	2.8	3.2	3.3	2.8	1.9
50	15.1	15.0	14.5	13.7	11.0	8.4	6.2	3.3	2.0	1.5	1.6	2.0	2.2	2.3	2.3	2.1	1.5
75	8.2	8.1	7.6	7.3	6.3	5.3	4.3	2.7	1.7	1.3	1.3	1.3	1.3	1.3	1.3	1.2	1.0
100	5.1	5.0	4.8	4.6	4.1	3.6	3.2	2.2	1.5	1.2	1.0	1.0	0.99	0.98	0.9	0.88	0.79
125	3.5	3.4	3.3	3.2	2.9	2.7	2.4	1.8	1.3	1.0	0.88	0.82	0.81	0.79	0.75	0.71	0.64
150	2.5	2.5	2.4	2.4	2.2	2.0	1.9	1.5	1.2	0.92	0.77	0.71	0.69	0.67	0.63	0.59	0.54
200	1.5	1.5	1.4	1.4	1.4	1.3	1.2	1.0	0.86	0.71	0.60	0.56	0.54	0.53	0.49	0.46	0.44
250	1.0	1.0	1.0	1.0	0.92	0.89	0.85	0.78	0.66	0.57	0.49	0.45	0.43	0.42	0.40	0.39	0.37

Table A7.4 (continuation)

Equivalent dose rate from Pixel + VI, Scenario 2 for T= 10 y, t= 30d

R\Z	0	20	40	50	70	88.5	107	150	200	250	300	325	335	345	365	380	400
0															206.6	13.0	3.2
5				111.6	32.4	18.8	12.2	5.7	4.0	3.6	4.2	6.7	11.4	44.2	205.0	12.1	3.2
10				96.4	31.5	17.8	11.1	4.3	2.7	2.3	2.9	5.1	8.6	18.2	38.6	10.1	3.1
15	59.0	64.1		76.9	33.4	18.7	11.5	3.9	2.3	1.9	2.4	4.4	6.8	11.4	18.0	7.9	2.9
23	34.3	36.1	44.3	47.0	28.6	16.6	10.3	3.6	2.1	1.7	2.1	3.5	4.8	6.6	8.3	5.3	2.5
30	25.0	25.9	28.4	27.6	19.1	12.3	8.0	3.4	2.0	1.5	1.9	2.9	3.7	4.6	5.2	3.9	2.2
40	17.5	17.8	17.9	17.0	13.0	9.2	6.5	3.1	1.8	1.4	1.7	2.3	2.6	3.0	3.2	2.6	1.8
50	13.0	13.0	12.6	11.9	9.6	7.3	5.4	2.9	1.7	1.3	1.5	1.8	2.0	2.2	2.2	1.9	1.5
75	7.1	7.0	6.6	6.3	5.5	4.6	3.8	2.4	1.5	1.2	1.1	1.2	1.2	1.3	1.2	1.1	1.0
100	4.4	4.4	4.2	4.0	3.6	3.2	2.8	1.9	1.3	1.0	0.93	0.91	0.91	0.90	0.9	0.81	0.72
125	3.0	3.0	2.9	2.8	2.6	2.3	2.1	1.6	1.2	0.9	0.79	0.74	0.73	0.71	0.67	0.63	0.58
150	2.2	2.2	2.1	2.0	1.9	1.8	1.6	1.3	1.0	0.81	0.68	0.64	0.62	0.60	0.56	0.54	0.49
200	1.3	1.3	1.3	1.2	1.2	1.1	1.1	0.92	0.76	0.63	0.54	0.50	0.48	0.46	0.44	0.42	0.39
250	0.85	0.85	0.84	0.83	0.81	0.77	0.75	0.68	0.58	0.50	0.43	0.40	0.39	0.37	0.35	0.34	0.32

Table A7.4 (continuation)

Equivalent dose rate from Pixel + VI, Scenario 2 for T= 10 y, t= 100d

R\Z	0	20	40	50	70	88.5	107	150	200	250	300	325	335	345	365	380	400
0															195.7	12.2	3.0
5				84.5	24.2	13.3	8.2	3.4	2.2	2.0	2.6	5.0	9.4	40.4	194.2	11.3	2.9
10				73.6	24.1	12.9	7.8	2.9	1.7	1.4	2.0	4.2	7.5	16.6	36.4	9.4	2.8
15	42.4	46.0		59.5	26.1	13.6	8.1	2.7	1.6	1.3	1.8	3.7	6.0	10.4	16.8	7.4	2.6
23	24.7	26.1	32.8	36.7	22.4	12.1	7.4	2.5	1.4	1.2	1.7	3.0	4.3	6.0	7.7	4.9	2.3
30	18.1	18.8	21.1	21.0	14.6	9.1	5.9	2.4	1.4	1.1	1.5	2.5	3.2	4.1	4.8	3.5	2.0
40	12.7	13.0	13.3	12.8	9.8	6.9	4.8	2.2	1.3	1.1	1.3	1.9	2.3	2.7	2.9	2.4	1.6
50	9.5	9.5	9.3	8.9	7.2	5.5	4.0	2.1	1.3	1.0	1.2	1.6	1.7	1.9	2.0	1.7	1.3
75	5.2	5.2	4.9	4.7	4.1	3.4	2.8	1.7	1.1	0.89	0.92	1.0	1.0	1.1	1.0	0.97	0.83
100	3.3	3.2	3.1	3.0	2.7	2.4	2.0	1.4	0.99	0.79	0.73	0.74	0.74	0.74	0.71	0.67	0.61
125	2.2	2.2	2.1	2.1	1.9	1.7	1.5	1.2	0.86	0.69	0.61	0.60	0.59	0.58	0.55	0.52	0.48
150	1.6	1.6	1.6	1.5	1.4	1.3	1.2	1.0	0.75	0.61	0.53	0.51	0.48	0.47	0.45	0.43	0.40
200	1.0	1.0	0.93	0.93	0.88	0.84	0.79	0.69	0.57	0.47	0.41	0.38	0.37	0.36	0.34	0.33	0.31
250	0.63	0.63	0.62	0.61	0.61	0.59	0.56	0.50	0.44	0.38	0.33	0.31	0.30	0.29	0.28	0.27	0.25

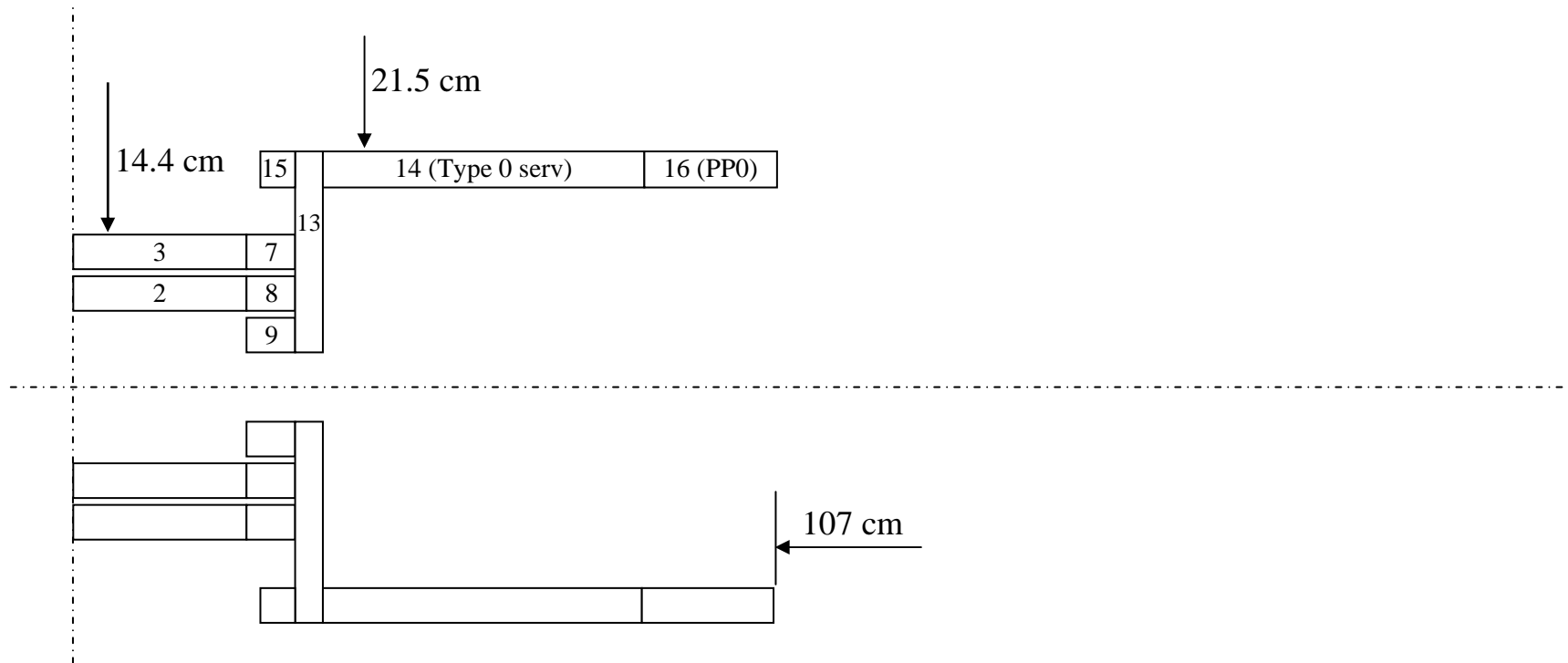

Fig. A7.3 Scenario 3-- Pixel Detector dismantled.

Table A7.5

Equivalent dose rate from Pixel, Scenario 3 for T= 100d, t= 5d

R\Z	0	20	40	50	70	88.5	107	150	200	250	300	325	335	345	365	380	400
0	38.8	42.1	64.6	50.1	16.6	10.7	6.8	2.0	0.90	0.53	0.36	0.30	0.28	0.26	0.23	0.21	0.19
5	41.1	44.6	73.5	52.4	16.6	10.9	6.9	2.0	0.90	0.53	0.36	0.30	0.28	0.26	0.23	0.21	0.19
10				49.7	16.8	11.4	7.2	2.0	0.90	0.53	0.36	0.30	0.28	0.26	0.23	0.21	0.19
15	35.3	39.7		40.8	17.9	13.0	8.1	1.9	0.90	0.53	0.36	0.29	0.28	0.26	0.23	0.21	0.19
23	19.7	20.9	26.0	24.4	15.4	11.6	7.3	1.9	0.89	0.52	0.36	0.29	0.28	0.26	0.23	0.21	0.19
30	14.2	14.9	16.1	15.0	10.5	7.7	5.2	1.8	0.87	0.52	0.36	0.29	0.28	0.26	0.23	0.21	0.19
40	9.9	10.1	10.1	9.4	7.3	5.5	3.9	1.7	0.85	0.51	0.35	0.29	0.27	0.26	0.23	0.21	0.19
50	7.3	7.3	7.1	6.7	5.4	4.2	3.2	1.6	0.83	0.50	0.35	0.29	0.27	0.26	0.23	0.21	0.19
75	4.0	3.9	3.7	3.5	3.1	2.6	2.1	1.3	0.74	0.48	0.34	0.28	0.26	0.25	0.22	0.21	0.19
100	2.5	2.4	2.3	2.2	2.0	1.8	1.5	1.0	0.66	0.44	0.32	0.27	0.25	0.24	0.22	0.20	0.18
125	1.7	1.7	1.6	1.5	1.4	1.3	1.2	0.84	0.58	0.41	0.29	0.25	0.24	0.23	0.21	0.19	0.18
150	1.2	1.2	1.2	1.1	1.0	1.0	0.88	0.68	0.50	0.37	0.27	0.24	0.23	0.22	0.20	0.18	0.17
200	0.70	0.70	0.68	0.66	0.64	0.61	0.57	0.48	0.38	0.29	0.23	0.21	0.20	0.19	0.18	0.17	0.15
250	0.45	0.45	0.44	0.44	0.43	0.41	0.39	0.35	0.29	0.24	0.20	0.18	0.17	0.17	0.16	0.15	0.14

Table A7.5 (continuation)

Equivalent dose rate from Pixel, Scenario 3 for T= 100d, t= 7 d

R\Z	0	20	40	50	70	88.5	107	150	200	250	300	325	335	345	365	380	400
0	35.0	38.1	59.4	46.3	15.3	9.9	6.2	1.8	0.83	0.49	0.33	0.27	0.25	0.24	0.21	0.20	0.18
5	37.1	40.3	67.6	48.6	15.3	10.0	6.3	1.8	0.83	0.49	0.33	0.27	0.25	0.24	0.21	0.20	0.18
10				46.0	15.5	10.5	6.6	1.8	0.83	0.49	0.33	0.27	0.25	0.24	0.21	0.20	0.18
15	31.9	35.9		37.8	16.6	12.0	7.4	1.8	0.82	0.48	0.33	0.27	0.25	0.24	0.21	0.20	0.18
23	17.8	19.0	23.9	22.6	14.3	10.7	6.6	1.7	0.81	0.48	0.33	0.27	0.25	0.24	0.21	0.20	0.18
30	12.9	13.6	14.8	13.9	9.7	7.1	4.7	1.7	0.80	0.48	0.33	0.27	0.25	0.24	0.21	0.20	0.18
40	9.0	9.2	9.2	8.7	6.7	5.0	3.6	1.6	0.78	0.47	0.32	0.27	0.25	0.24	0.21	0.19	0.18
50	6.7	6.7	6.5	6.1	5.0	3.9	2.9	1.4	0.76	0.46	0.32	0.26	0.25	0.23	0.21	0.19	0.18
75	3.7	3.6	3.4	3.3	2.8	2.4	2.0	1.2	0.68	0.44	0.31	0.26	0.24	0.23	0.20	0.19	0.17
100	2.3	2.2	2.1	2.0	1.8	1.6	1.4	0.95	0.60	0.41	0.28	0.25	0.23	0.22	0.20	0.18	0.17
125	1.5	1.5	1.5	1.4	1.3	1.2	1.0	0.77	0.53	0.37	0.27	0.23	0.22	0.21	0.19	0.18	0.16
150	1.1	1.1	1.1	1.0	0.96	0.89	0.81	0.63	0.46	0.34	0.25	0.22	0.21	0.20	0.18	0.17	0.16
200	0.65	0.63	0.62	0.61	0.58	0.56	0.53	0.44	0.35	0.27	0.21	0.19	0.18	0.18	0.16	0.15	0.14
250	0.42	0.41	0.41	0.40	0.39	0.38	0.36	0.32	0.26	0.22	0.18	0.17	0.16	0.15	0.14	0.14	0.13

Table A7.5 (continuation)

Equivalent dose rate from Pixel, Scenario 3 for T= 100d, t= 15 d

R\Z	0	20	40	50	70	88.5	107	150	200	250	300	325	335	345	365	380	400
0	27.3	30.0	48.5	38.9	12.8	8.1	5.1	1.5	0.68	0.40	0.27	0.22	0.21	0.20	0.17	0.16	0.15
5	28.9	31.6	54.9	40.9	12.8	8.2	5.1	1.5	0.68	0.40	0.27	0.22	0.21	0.20	0.17	0.16	0.15
10				38.7	13.0	8.6	5.3	1.5	0.68	0.40	0.27	0.22	0.21	0.20	0.17	0.16	0.15
15	25.0	28.2		31.8	13.9	9.7	6.0	1.5	0.67	0.40	0.27	0.22	0.21	0.20	0.17	0.16	0.15
23	14.1	15.2	19.6	19.0	12.0	8.7	5.4	1.4	0.67	0.39	0.27	0.22	0.21	0.19	0.17	0.16	0.15
30	10.3	10.9	12.1	11.5	8.1	5.8	3.9	1.3	0.66	0.39	0.27	0.22	0.21	0.19	0.17	0.16	0.14
40	7.2	7.4	7.5	7.1	5.5	4.1	2.9	1.3	0.63	0.38	0.27	0.22	0.20	0.19	0.17	0.16	0.14
50	5.4	5.4	5.3	5.0	4.1	3.2	2.4	1.2	0.61	0.38	0.25	0.22	0.20	0.19	0.17	0.16	0.14
75	3.0	2.9	2.8	2.6	2.3	2.0	1.6	0.95	0.55	0.36	0.24	0.21	0.20	0.19	0.17	0.15	0.14
100	1.8	1.8	1.7	1.7	1.5	1.3	1.1	0.77	0.49	0.33	0.23	0.20	0.19	0.18	0.16	0.15	0.14
125	1.2	1.2	1.2	1.1	1.1	1.0	0.85	0.63	0.42	0.30	0.22	0.19	0.18	0.17	0.16	0.14	0.13
150	0.90	0.89	0.85	0.83	0.78	0.72	0.66	0.51	0.37	0.28	0.20	0.18	0.17	0.16	0.15	0.14	0.13
200	0.52	0.52	0.50	0.50	0.48	0.45	0.43	0.36	0.29	0.22	0.17	0.16	0.15	0.14	0.13	0.13	0.12
250	0.34	0.34	0.33	0.33	0.32	0.31	0.30	0.26	0.21	0.18	0.15	0.14	0.13	0.13	0.12	0.11	0.10

Table A7.5 (continuation)

Equivalent dose rate from Pixel, Scenario 3 for T= 100d, t= 30 d

R\Z	0	20	40	50	70	88.5	107	150	200	250	300	325	335	345	365	380	400
0	21.2	23.4	39.1	32.3	10.5	6.5	4.0	1.2	0.54	0.32	0.21	0.18	0.17	0.16	0.14	0.13	0.12
5	22.4	24.7	44.0	34.0	10.5	6.6	4.1	1.2	0.54	0.32	0.21	0.18	0.17	0.16	0.14	0.13	0.12
10				32.1	10.7	6.9	4.2	1.2	0.54	0.32	0.21	0.18	0.17	0.16	0.14	0.13	0.12
15	19.5	22.1		26.5	11.5	7.7	4.7	1.2	0.54	0.32	0.21	0.18	0.17	0.16	0.14	0.13	0.12
23	11.1	12.0	15.9	15.8	9.9	6.9	4.3	1.1	0.53	0.32	0.21	0.18	0.17	0.16	0.14	0.13	0.12
30	8.1	8.6	9.8	9.4	6.6	4.7	3.1	1.1	0.52	0.31	0.21	0.18	0.17	0.16	0.14	0.13	0.12
40	5.7	5.9	6.1	5.8	4.5	3.3	2.4	1.0	0.51	0.31	0.21	0.18	0.16	0.16	0.14	0.13	0.12
50	4.3	4.3	4.3	4.1	3.3	2.6	1.9	0.95	0.49	0.31	0.20	0.17	0.16	0.15	0.14	0.13	0.12
75	2.4	2.4	2.2	2.1	1.9	1.6	1.3	0.77	0.45	0.29	0.20	0.17	0.16	0.15	0.14	0.13	0.11
100	1.5	1.5	1.4	1.3	1.2	1.1	0.92	0.62	0.40	0.27	0.19	0.16	0.15	0.14	0.13	0.12	0.11
125	1.0	0.99	0.95	0.92	0.85	0.78	0.69	0.50	0.34	0.25	0.18	0.15	0.15	0.14	0.13	0.12	0.11
150	0.72	0.71	0.69	0.67	0.63	0.58	0.53	0.42	0.30	0.23	0.16	0.14	0.14	0.13	0.12	0.11	0.10
200	0.42	0.42	0.41	0.40	0.39	0.37	0.34	0.29	0.23	0.18	0.14	0.13	0.12	0.12	0.11	0.10	0.09
250	0.27	0.27	0.27	0.27	0.26	0.25	0.24	0.21	0.17	0.14	0.12	0.11	0.11	0.10	0.10	0.09	0.09

Table A7.5 (continuation)

Equivalent dose rate from Pixel, Scenario 3 for T= 100d, t= 100 d

R\Z	0	20	40	50	70	88.5	107	150	200	250	300	325	335	345	365	380	400
0	12.5	13.8	23.6	20.9	6.7	3.9	2.4	0.71	0.33	0.20	0.13	0.11	0.10	0.10	0.09	0.08	0.07
5	13.2	14.5	26.2	22.2	6.7	3.9	2.4	0.71	0.33	0.20	0.13	0.11	0.10	0.10	0.09	0.08	0.07
10				20.7	6.9	4.1	2.5	0.71	0.33	0.20	0.13	0.11	0.10	0.10	0.09	0.08	0.07
15	11.6	13.1		17.2	7.5	4.5	2.7	0.70	0.33	0.20	0.13	0.11	0.10	0.10	0.09	0.08	0.07
23	6.6	7.2	9.8	10.4	6.4	4.0	2.5	0.68	0.33	0.20	0.13	0.11	0.10	0.10	0.09	0.08	0.07
30	4.9	5.2	6.1	6.0	4.2	2.8	1.8	0.66	0.32	0.20	0.13	0.11	0.10	0.10	0.09	0.08	0.07
40	3.5	3.6	3.8	3.6	2.8	2.0	1.4	0.62	0.32	0.19	0.13	0.11	0.10	0.10	0.09	0.08	0.07
50	2.6	2.6	2.6	2.5	2.1	1.6	1.2	0.57	0.31	0.19	0.13	0.11	0.10	0.10	0.09	0.08	0.07
75	1.4	1.4	1.4	1.3	1.1	1.0	0.79	0.47	0.27	0.18	0.12	0.10	0.10	0.09	0.08	0.08	0.07
100	0.91	0.89	0.86	0.82	0.74	0.65	0.56	0.38	0.24	0.16	0.12	0.10	0.10	0.09	0.08	0.08	0.07
125	0.61	0.60	0.58	0.57	0.52	0.47	0.42	0.31	0.21	0.15	0.11	0.10	0.09	0.09	0.08	0.07	0.07
150	0.44	0.43	0.42	0.41	0.39	0.35	0.33	0.25	0.19	0.13	0.10	0.09	0.09	0.08	0.08	0.07	0.07
200	0.26	0.25	0.25	0.24	0.23	0.22	0.21	0.18	0.14	0.11	0.09	0.08	0.08	0.07	0.07	0.06	0.06
250	0.17	0.17	0.17	0.17	0.16	0.15	0.14	0.13	0.11	0.09	0.08	0.07	0.07	0.07	0.06	0.05	0.05

Table A7.6

Equivalent dose rate from Pixel, Scenario 3 for T= 10 y, t= 5d

R\Z	0	20	40	50	70	88.5	107	150	200	250	300	325	335	345	365	380	400
0	59.0	64.8	108.0	97.2	31.3	18.4	11.2	3.4	1.5	0.92	0.61	0.51	0.48	0.45	0.40	0.36	0.33
5	62.4	68.3	119.0	103.5	31.5	18.6	11.3	3.4	1.5	0.92	0.61	0.51	0.48	0.45	0.40	0.36	0.33
10				95.4	32.3	19.3	11.7	3.3	1.5	0.92	0.61	0.51	0.48	0.45	0.40	0.36	0.33
15	54.0	60.9		78.7	35.3	21.4	12.9	3.3	1.5	0.91	0.61	0.51	0.48	0.45	0.40	0.36	0.33
23	30.8	33.2	44.3	48.0	30.3	19.1	11.6	3.2	1.5	0.91	0.61	0.51	0.48	0.45	0.40	0.36	0.33
30	22.6	24.0	27.9	27.6	19.7	13.2	8.6	3.1	1.5	0.90	0.60	0.51	0.48	0.45	0.40	0.36	0.33
40	16.1	16.6	17.3	16.7	13.2	9.5	6.7	2.9	1.5	0.89	0.60	0.50	0.47	0.45	0.40	0.36	0.33
50	12.0	12.2	12.1	11.6	9.6	7.4	5.5	2.7	1.4	0.86	0.59	0.50	0.47	0.44	0.40	0.36	0.32
75	6.7	6.6	6.3	6.1	5.3	4.5	3.7	2.2	1.3	0.82	0.57	0.48	0.45	0.43	0.39	0.35	0.32
100	4.2	4.1	4.0	3.8	3.4	3.0	2.6	1.8	1.1	0.76	0.53	0.46	0.44	0.41	0.36	0.34	0.31
125	2.8	2.8	2.7	2.6	2.4	2.2	2.0	1.4	0.98	0.69	0.50	0.44	0.42	0.40	0.35	0.33	0.30
150	2.0	2.0	2.0	1.9	1.8	1.7	1.5	1.2	0.86	0.63	0.47	0.41	0.40	0.37	0.33	0.31	0.29
200	1.2	1.2	1.2	1.1	1.1	1.0	0.98	0.81	0.65	0.51	0.40	0.35	0.34	0.33	0.30	0.28	0.26
250	0.78	0.77	0.76	0.75	0.73	0.71	0.68	0.59	0.50	0.41	0.34	0.31	0.30	0.29	0.27	0.25	0.24

Table A7.6 (continuation)

Equivalent dose rate from Pixel, Scenario 3 for T= 10 y, t= 7 d

R\Z	0	20	40	50	70	88.5	107	150	200	250	300	325	335	345	365	380	400
0	55.1	60.6	102.6	93.3	30.0	17.5	10.6	3.2	1.5	0.87	0.58	0.48	0.46	0.43	0.38	0.35	0.31
5	58.3	63.9	113.0	99.5	30.2	17.7	10.7	3.2	1.5	0.87	0.58	0.48	0.46	0.43	0.38	0.35	0.31
10				91.6	30.9	18.3	11.1	3.2	1.5	0.87	0.58	0.48	0.46	0.43	0.38	0.35	0.31
15	50.5	57.1		75.6	33.9	20.3	12.2	3.1	1.5	0.87	0.58	0.48	0.46	0.43	0.38	0.35	0.31
23	28.9	31.3	42.2	46.1	29.1	18.1	11.0	3.0	1.4	0.86	0.58	0.48	0.45	0.43	0.38	0.34	0.31
30	21.3	22.7	26.5	26.4	18.9	12.6	8.2	2.9	1.4	0.86	0.57	0.48	0.45	0.43	0.38	0.34	0.31
40	15.2	15.7	16.5	16.0	12.6	9.1	6.3	2.7	1.4	0.84	0.57	0.48	0.45	0.42	0.38	0.34	0.31
50	11.4	11.5	11.5	11.1	9.2	7.0	5.2	2.5	1.3	0.82	0.56	0.47	0.45	0.42	0.38	0.34	0.31
75	6.3	6.3	6.0	5.8	5.1	4.3	3.5	2.1	1.2	0.78	0.54	0.46	0.43	0.41	0.36	0.33	0.30
100	4.0	3.9	3.8	3.6	3.3	2.9	2.5	1.7	1.1	0.72	0.51	0.44	0.42	0.39	0.35	0.32	0.29
125	2.7	2.7	2.6	2.5	2.3	2.1	1.9	1.4	0.93	0.65	0.48	0.42	0.40	0.38	0.33	0.31	0.28
150	1.9	1.9	1.9	1.8	1.7	1.6	1.4	1.1	0.81	0.60	0.45	0.39	0.38	0.35	0.32	0.30	0.27
200	1.1	1.1	1.1	1.1	1.0	0.98	0.92	0.77	0.61	0.48	0.38	0.34	0.32	0.31	0.29	0.27	0.25
250	0.74	0.73	0.72	0.72	0.69	0.67	0.64	0.57	0.47	0.39	0.32	0.29	0.28	0.27	0.25	0.24	0.22

Table A7.6 (continuation)

Equivalent dose rate from Pixel, Scenario 3 for T= 10 y, t= 15 d

R\Z	0	20	40	50	70	88.5	107	150	200	250	300	325	335	345	365	380	400
0	47.1	52.2	91.1	85.3	27.3	15.6	9.4	2.8	1.3	0.77	0.52	0.43	0.41	0.38	0.33	0.31	0.28
5	49.8	54.9	99.7	91.3	27.5	15.7	9.4	2.8	1.3	0.77	0.52	0.43	0.41	0.38	0.33	0.31	0.28
10				83.7	28.2	16.3	9.8	2.8	1.3	0.77	0.52	0.43	0.41	0.38	0.33	0.31	0.28
15	43.3	49.1		69.2	31.0	17.9	10.7	2.8	1.3	0.77	0.52	0.43	0.41	0.38	0.33	0.31	0.28
23	25.0	27.2	37.7	42.2	26.7	16.0	9.7	2.7	1.3	0.76	0.52	0.43	0.40	0.38	0.33	0.31	0.28
30	18.5	19.8	23.7	23.9	17.2	11.2	7.2	2.6	1.3	0.76	0.51	0.43	0.40	0.38	0.33	0.31	0.28
40	13.3	13.8	14.7	14.3	11.3	8.1	5.6	2.4	1.2	0.74	0.51	0.43	0.40	0.38	0.33	0.30	0.28
50	10.0	10.2	10.2	9.9	8.2	6.3	4.6	2.3	1.2	0.73	0.50	0.42	0.40	0.38	0.33	0.30	0.27
75	5.6	5.6	5.4	5.1	4.5	3.8	3.1	1.9	1.1	0.69	0.47	0.41	0.39	0.37	0.32	0.30	0.27
100	3.5	3.5	3.3	3.2	2.9	2.6	2.2	1.5	0.95	0.64	0.45	0.39	0.37	0.35	0.31	0.29	0.26
125	2.4	2.4	2.3	2.2	2.0	1.9	1.7	1.2	0.83	0.58	0.43	0.37	0.35	0.33	0.30	0.28	0.25
150	1.7	1.7	1.7	1.6	1.5	1.4	1.3	1.0	0.72	0.53	0.40	0.35	0.33	0.31	0.28	0.27	0.24
200	1.0	1.0	0.98	0.96	0.92	0.88	0.82	0.69	0.55	0.43	0.34	0.30	0.29	0.28	0.25	0.24	0.22
250	0.66	0.65	0.64	0.64	0.62	0.60	0.57	0.50	0.42	0.35	0.28	0.26	0.25	0.24	0.23	0.21	0.19

Table A7.6 (continuation)

Equivalent dose rate from Pixel, Scenario 3 for T= 10 y, t= 30 d

R\Z	0	20	40	50	70	88.5	107	150	200	250	300	325	335	345	365	380	400
0	40.5	45.0	80.7	77.8	24.8	13.9	8.2	2.5	1.2	0.68	0.46	0.38	0.36	0.34	0.30	0.27	0.25
5	42.7	47.3	87.6	83.5	24.9	14.0	8.3	2.5	1.2	0.68	0.46	0.38	0.36	0.34	0.30	0.27	0.25
10				76.2	25.7	14.4	8.5	2.5	1.2	0.68	0.46	0.38	0.36	0.34	0.30	0.27	0.25
15	37.3	42.4		63.2	28.3	15.7	9.3	2.5	1.2	0.68	0.46	0.38	0.36	0.34	0.30	0.27	0.25
23	21.7	23.7	33.5	38.6	24.4	14.0	8.4	2.4	1.1	0.68	0.46	0.38	0.36	0.34	0.30	0.27	0.25
30	16.2	17.4	21.1	21.6	15.5	10.0	6.4	2.3	1.1	0.67	0.46	0.38	0.36	0.34	0.29	0.27	0.25
40	11.6	12.1	13.1	12.8	10.2	7.2	5.0	2.2	1.1	0.66	0.45	0.38	0.36	0.34	0.29	0.27	0.25
50	8.8	9.0	9.1	8.8	7.4	5.6	4.1	2.0	1.1	0.65	0.44	0.38	0.35	0.33	0.29	0.27	0.24
75	5.0	4.9	4.8	4.6	4.0	3.4	2.8	1.6	0.95	0.62	0.42	0.36	0.34	0.33	0.28	0.26	0.24
100	3.1	3.1	3.0	2.9	2.6	2.3	2.0	1.3	0.85	0.56	0.40	0.35	0.33	0.30	0.28	0.26	0.23
125	2.1	2.1	2.0	2.0	1.8	1.6	1.5	1.1	0.74	0.52	0.38	0.33	0.31	0.29	0.26	0.25	0.23
150	1.5	1.5	1.5	1.4	1.3	1.2	1.1	0.88	0.64	0.47	0.36	0.30	0.29	0.28	0.25	0.24	0.22
200	0.90	0.89	0.87	0.85	0.82	0.77	0.73	0.61	0.49	0.38	0.30	0.27	0.26	0.25	0.23	0.21	0.20
250	0.58	0.58	0.57	0.57	0.55	0.52	0.50	0.45	0.37	0.31	0.25	0.23	0.22	0.22	0.20	0.19	0.17

Table A7.6 (continuation)

Equivalent dose rate from Pixel, Scenario 3 for T= 10 y, t= 100 d

R\Z	0	20	40	50	70	88.5	107	150	200	250	300	325	335	345	365	380	400
0	29.7	33.1	61.4	63.0	19.8	10.6	6.2	1.9	0.89	0.53	0.35	0.30	0.27	0.26	0.23	0.21	0.19
5	31.3	34.7	65.5	67.9	20.0	10.7	6.2	1.9	0.89	0.53	0.35	0.30	0.27	0.26	0.23	0.21	0.19
10				61.4	20.6	10.9	6.4	1.9	0.89	0.53	0.35	0.30	0.27	0.26	0.23	0.21	0.19
15	27.4	31.2		50.9	23.0	11.8	6.9	1.9	0.88	0.53	0.35	0.30	0.27	0.26	0.23	0.21	0.19
23	16.1	17.7	25.8	31.4	19.8	10.5	6.2	1.8	0.87	0.53	0.35	0.30	0.27	0.26	0.23	0.21	0.19
30	12.1	13.1	16.3	17.2	12.4	7.6	4.8	1.8	0.86	0.51	0.35	0.30	0.27	0.26	0.23	0.21	0.19
40	8.8	9.2	10.1	10.1	8.0	5.6	3.8	1.7	0.84	0.51	0.35	0.30	0.27	0.25	0.23	0.21	0.19
50	6.7	6.9	7.0	6.9	5.7	4.4	3.2	1.5	0.82	0.50	0.34	0.29	0.27	0.25	0.23	0.21	0.19
75	3.8	3.8	3.7	3.5	3.1	2.6	2.1	1.3	0.73	0.47	0.33	0.27	0.26	0.25	0.22	0.21	0.19
100	2.4	2.4	2.3	2.2	2.0	1.8	1.5	1.0	0.66	0.44	0.31	0.26	0.25	0.24	0.21	0.20	0.18
125	1.6	1.6	1.6	1.5	1.4	1.3	1.1	0.83	0.57	0.41	0.30	0.25	0.24	0.23	0.21	0.19	0.18
150	1.2	1.2	1.1	1.1	1.0	0.96	0.88	0.68	0.49	0.36	0.27	0.24	0.23	0.22	0.20	0.18	0.16
200	0.69	0.68	0.67	0.66	0.63	0.60	0.56	0.47	0.37	0.30	0.23	0.21	0.20	0.19	0.18	0.16	0.15
250	0.45	0.45	0.44	0.43	0.42	0.41	0.39	0.34	0.29	0.24	0.20	0.18	0.18	0.16	0.15	0.14	0.13