

June 2006

Side A

The scenario starts with the field mapping in June 2006 !

There will be no JD on side A for the mapping !

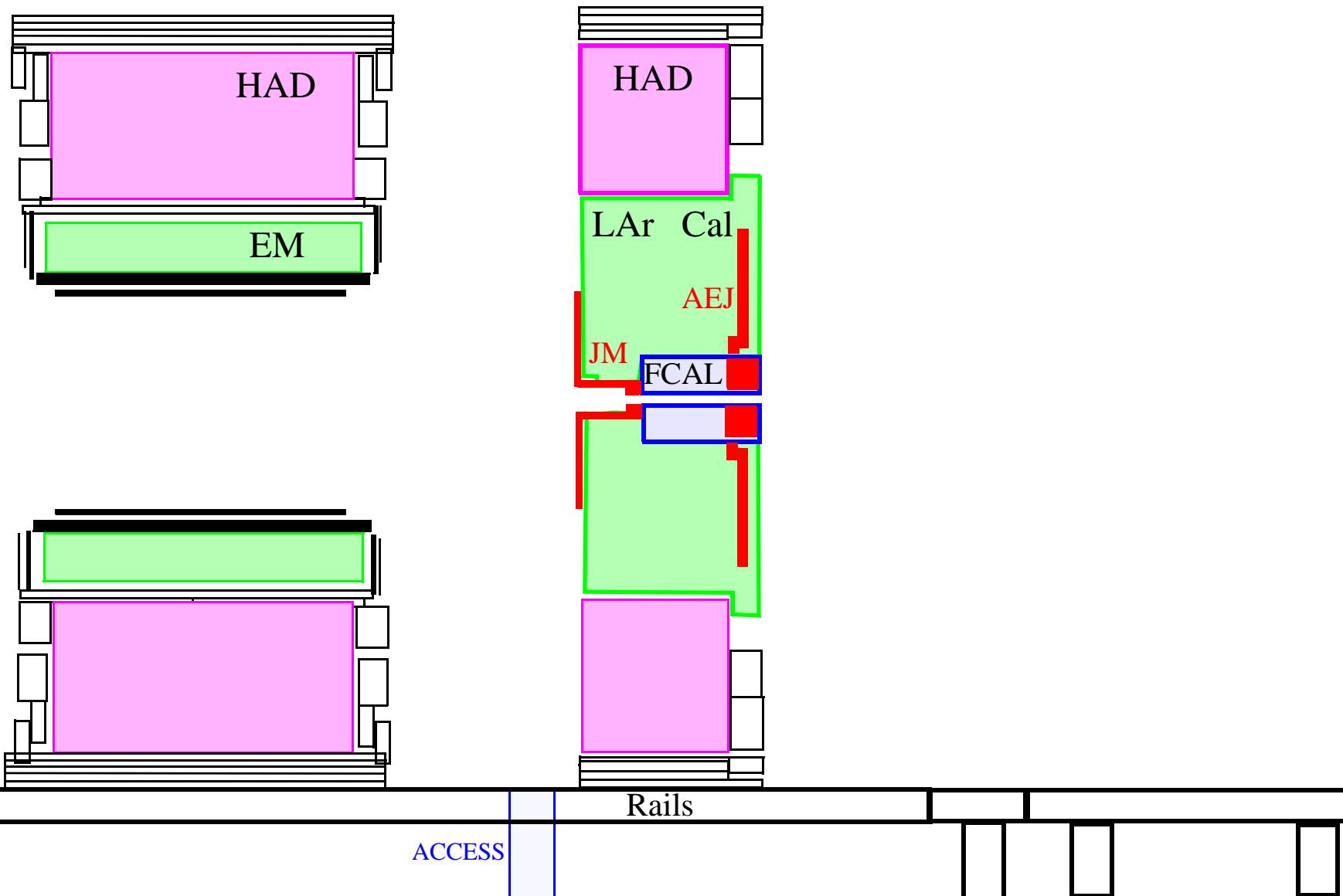

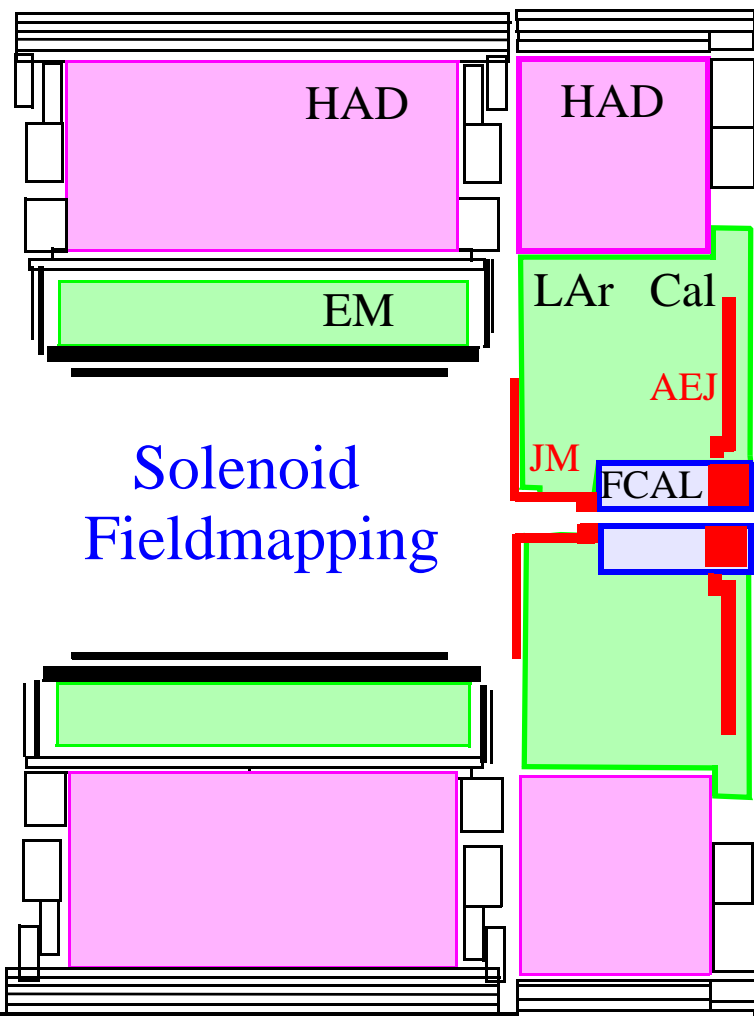

Solenoid
Fieldmapping

1.7m

Rails

Half truck

HF truck

ACCESS

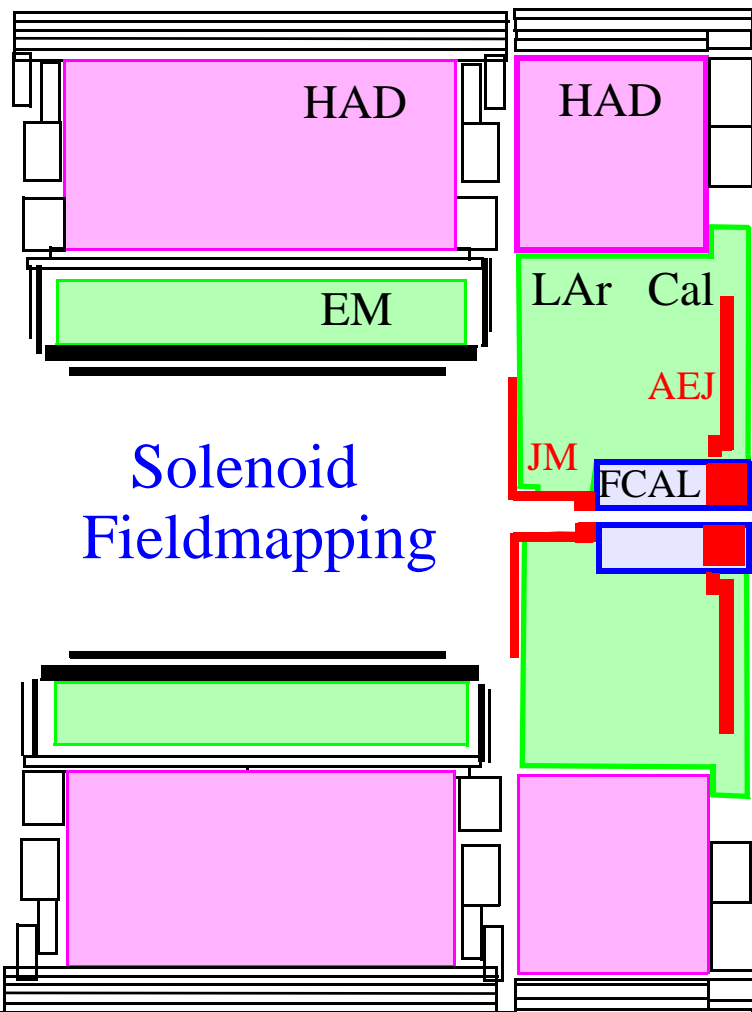

Solenoid
Fieldmapping

Rails

ACCESS

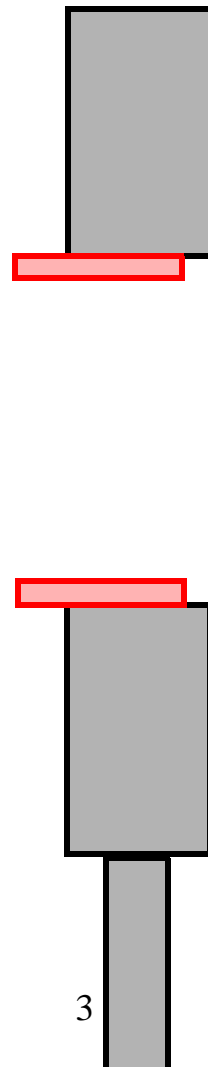

Can the JN monobloc be installed already at this stage ?



OPAL BEAMS

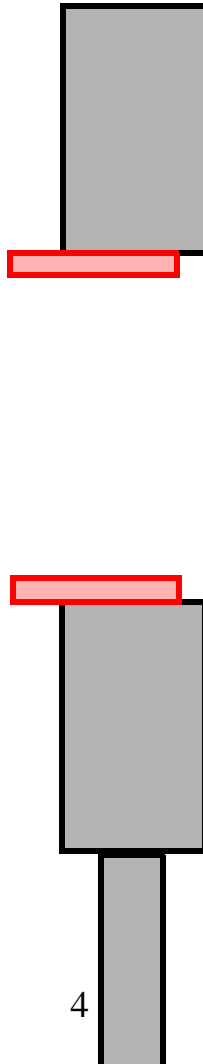
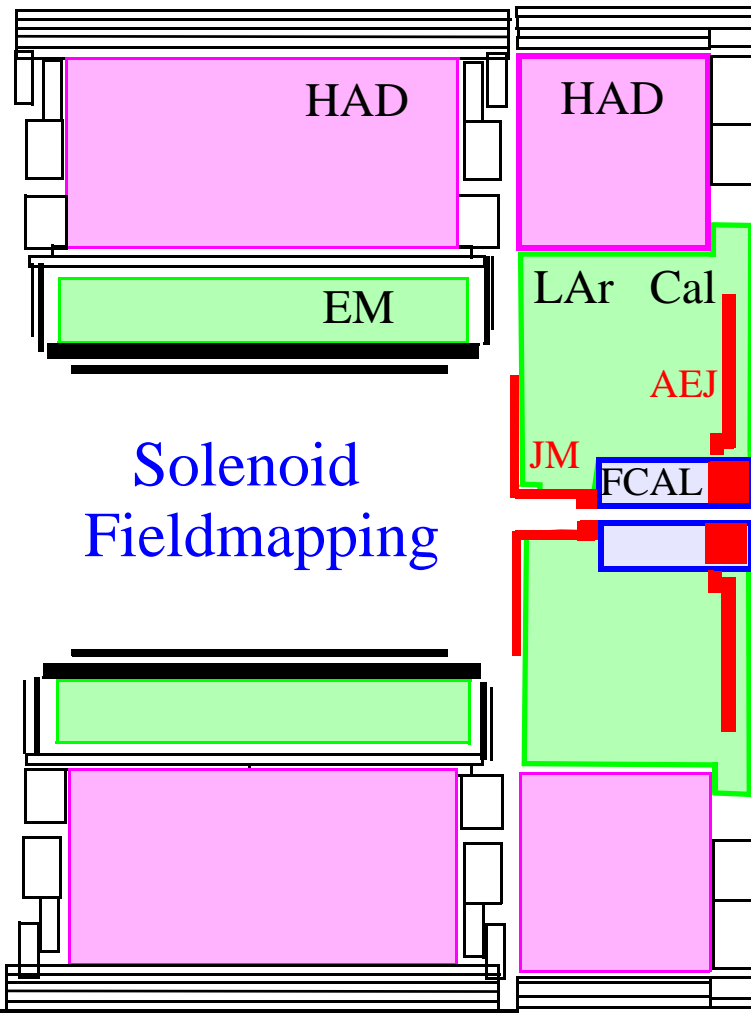

ACCESS

Rails

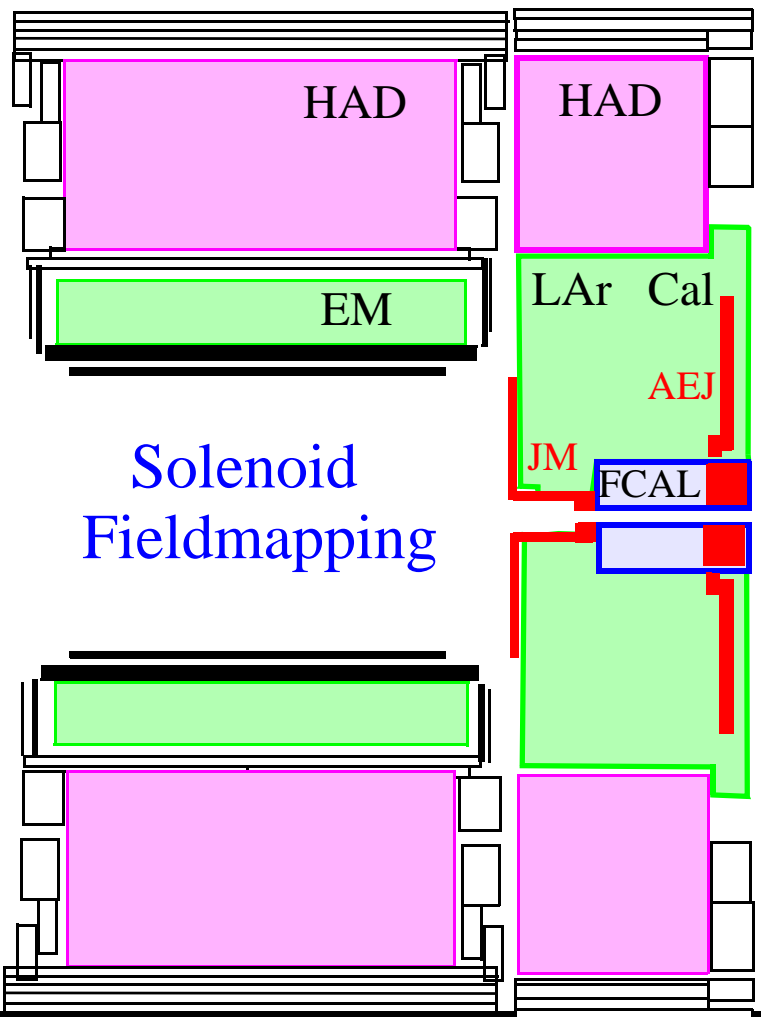

Solenoid
Fieldmapping

Rails

ACCESS

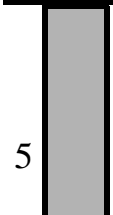
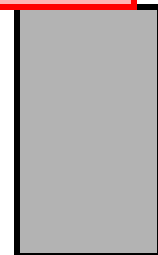
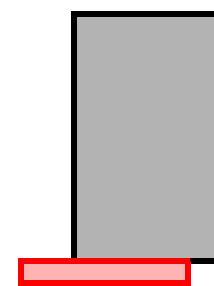

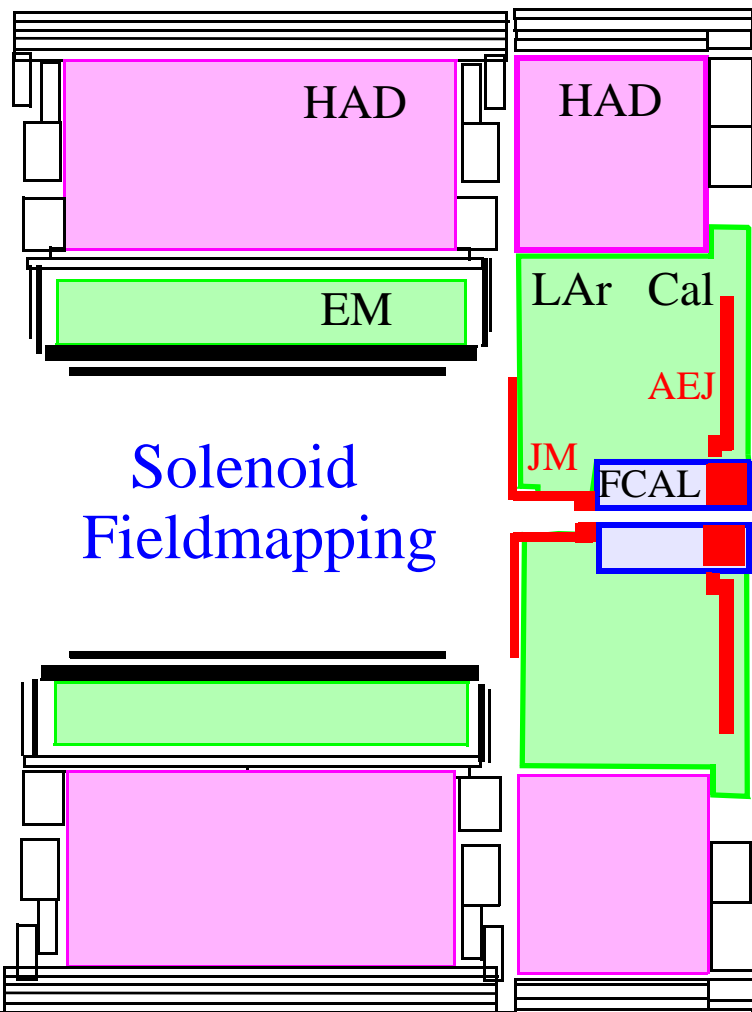

Solenoid
Fieldmapping

Rails

ACCESS

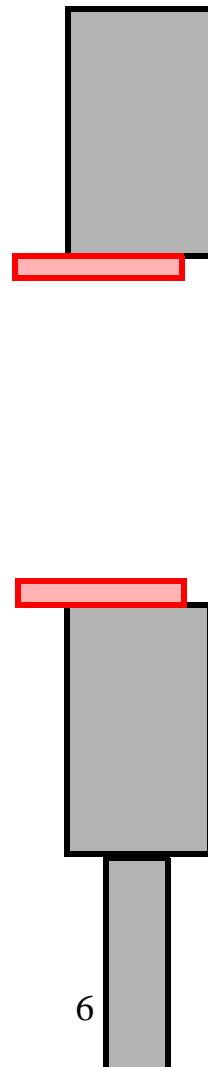

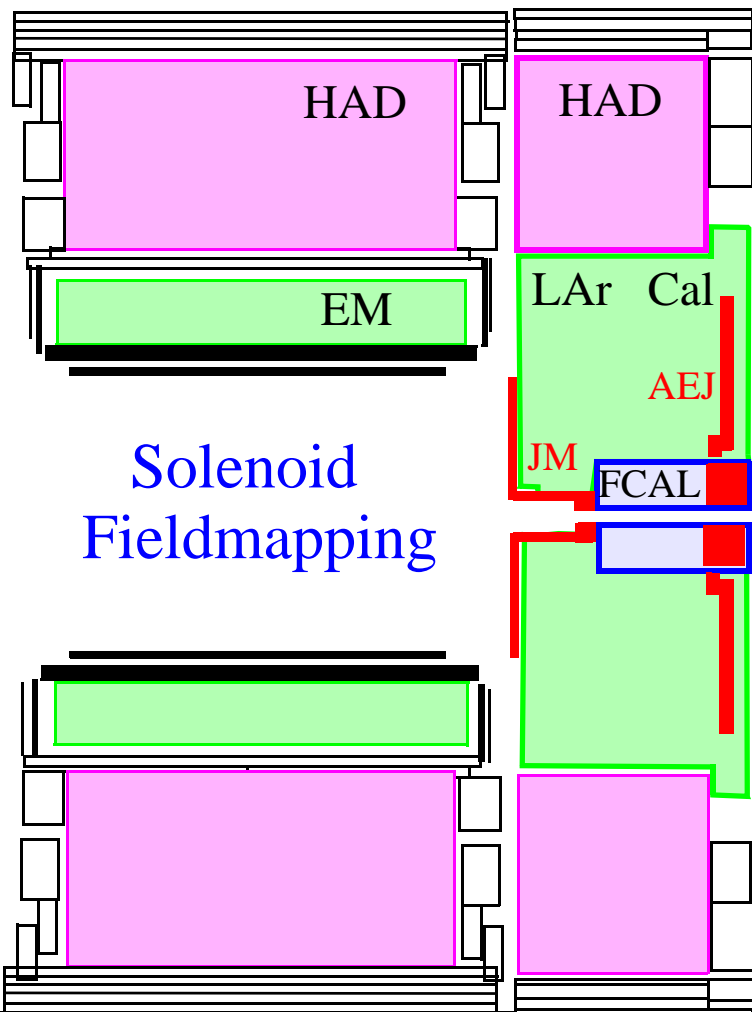

Solenoid
Fieldmapping

Rails

ACCESS

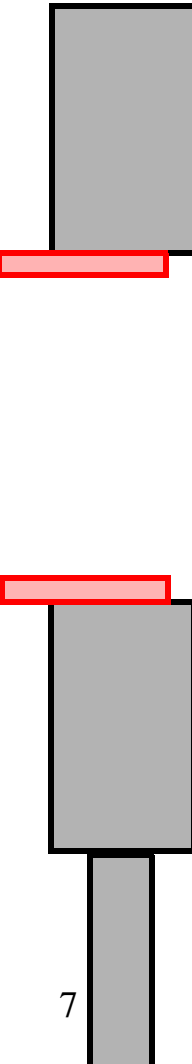

JF LIFTING FRAME

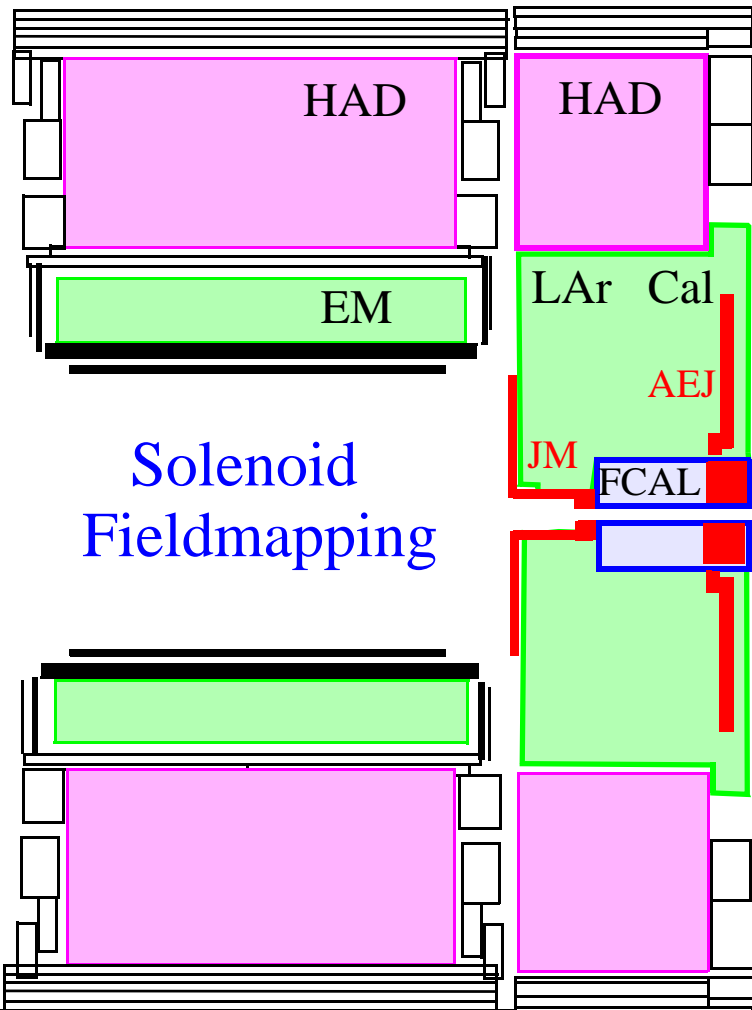

Solenoid
Fieldmapping

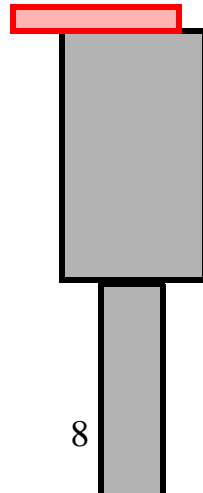
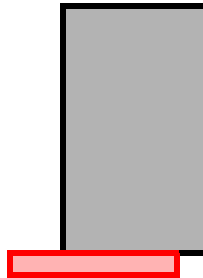
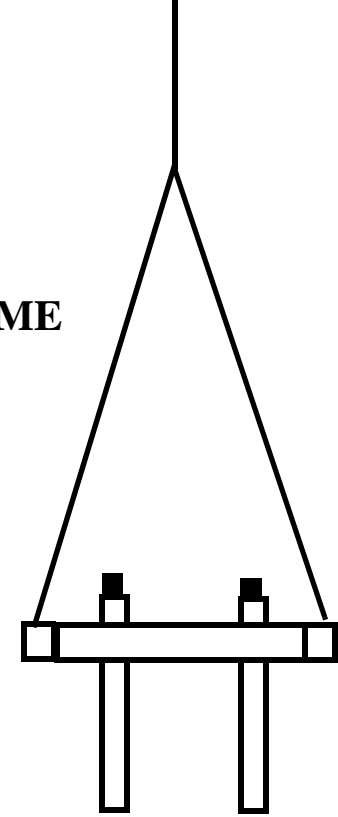

Rails

ACCESS

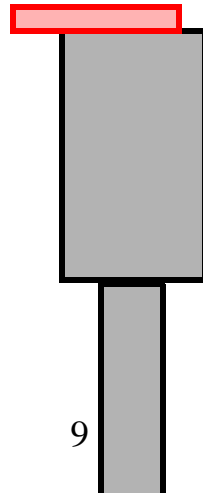
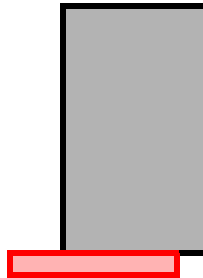
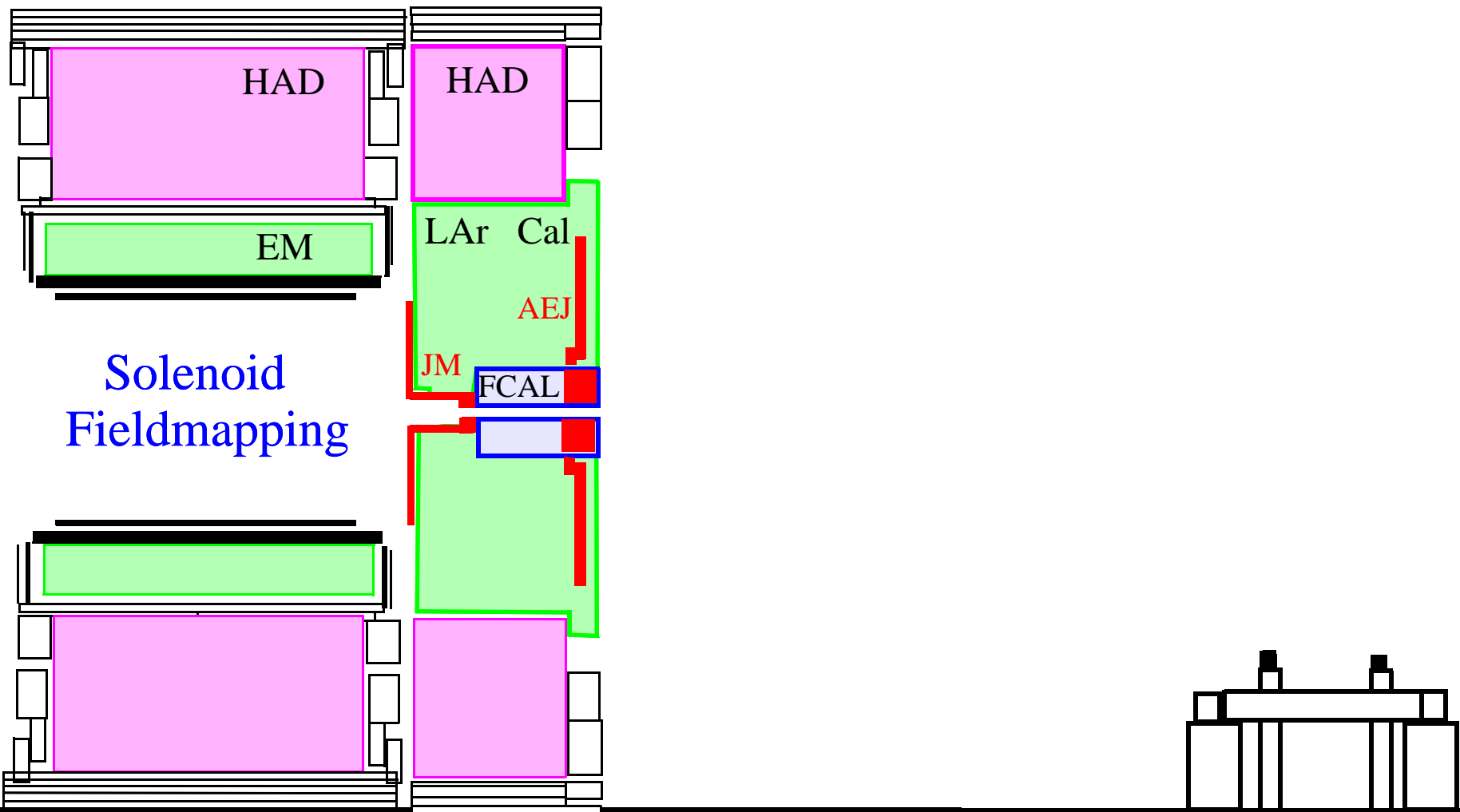

ACCESS

Rails

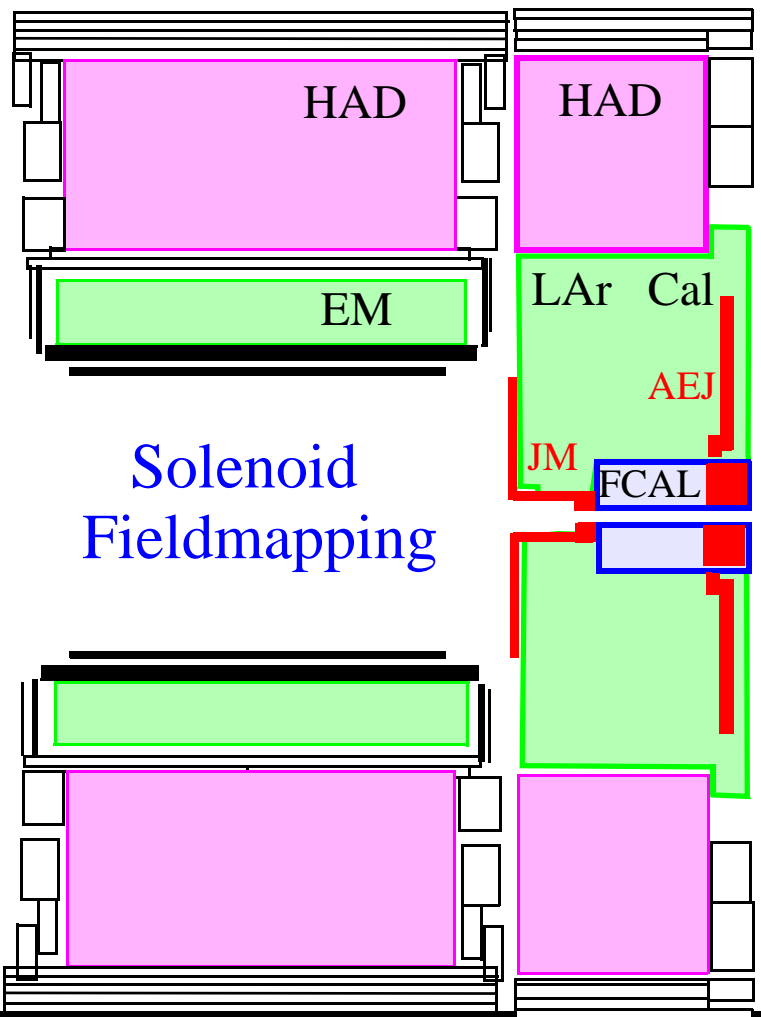

Solenoid
Fieldmapping

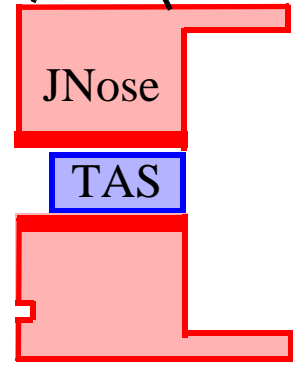

ACCESS

Rails

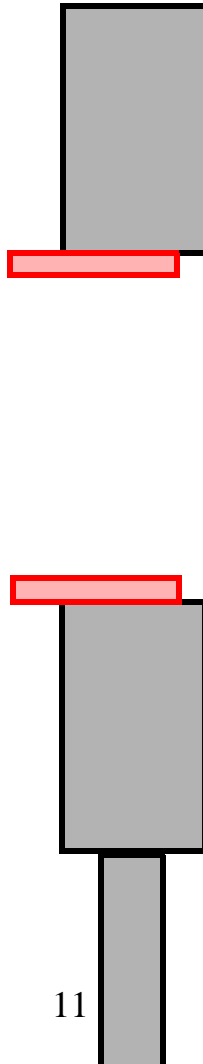
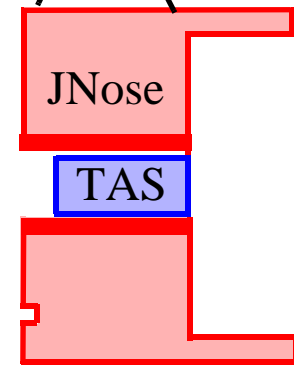
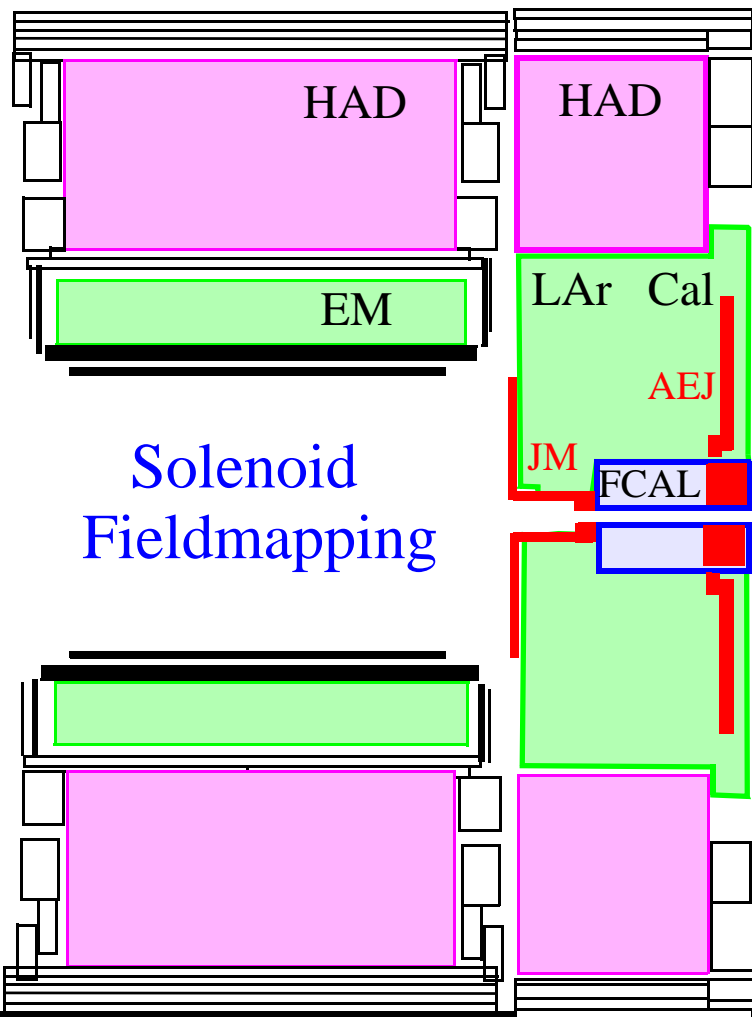

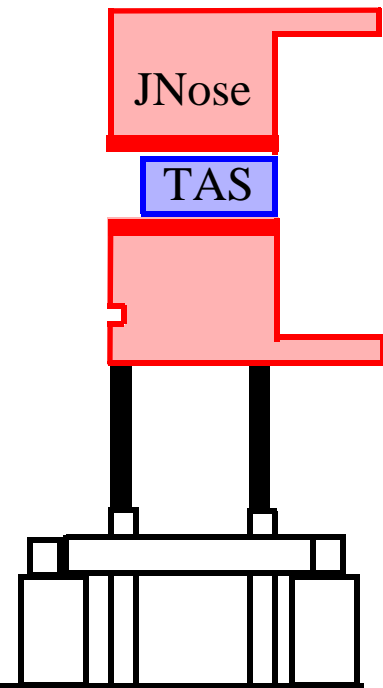
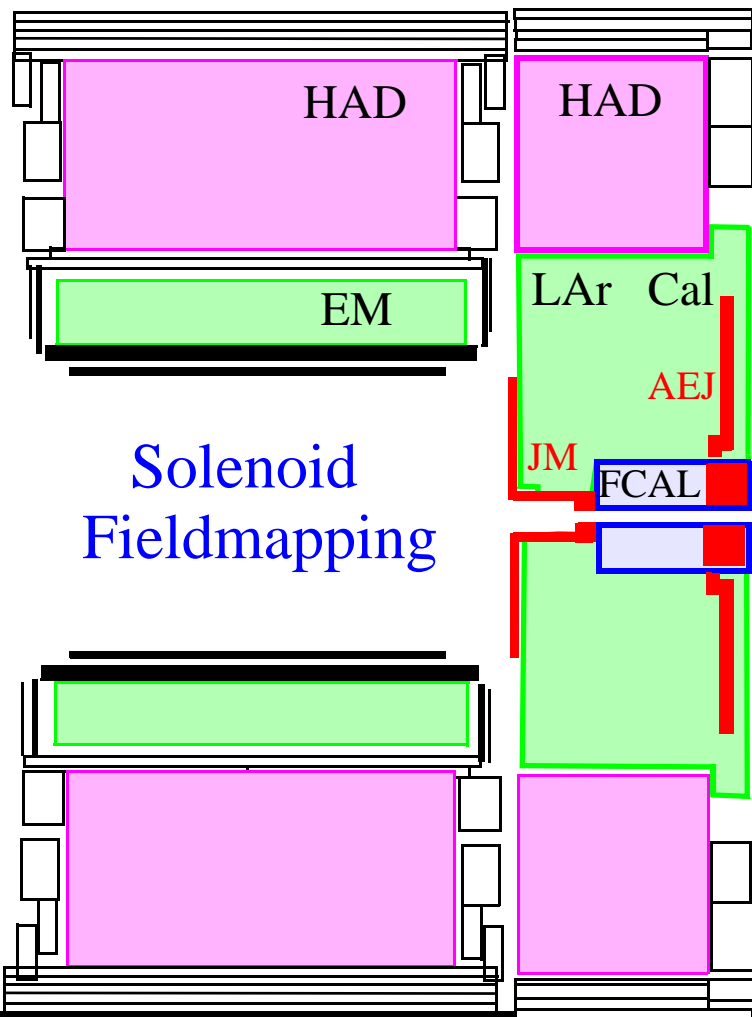

Rails

ACCESS

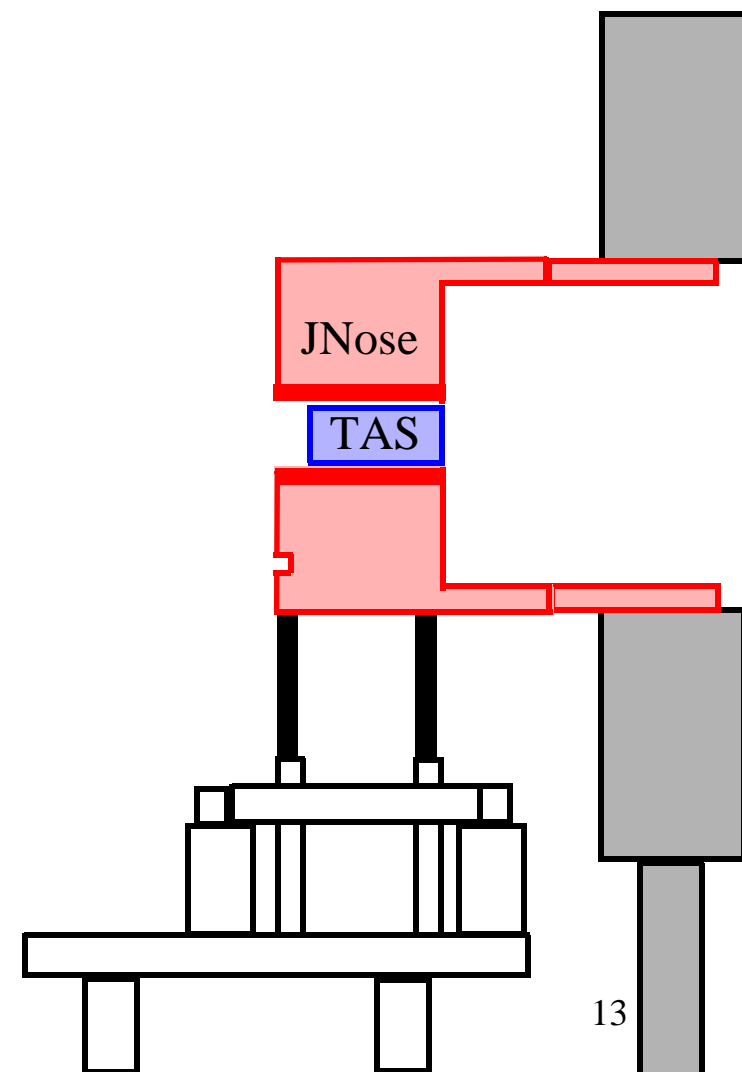
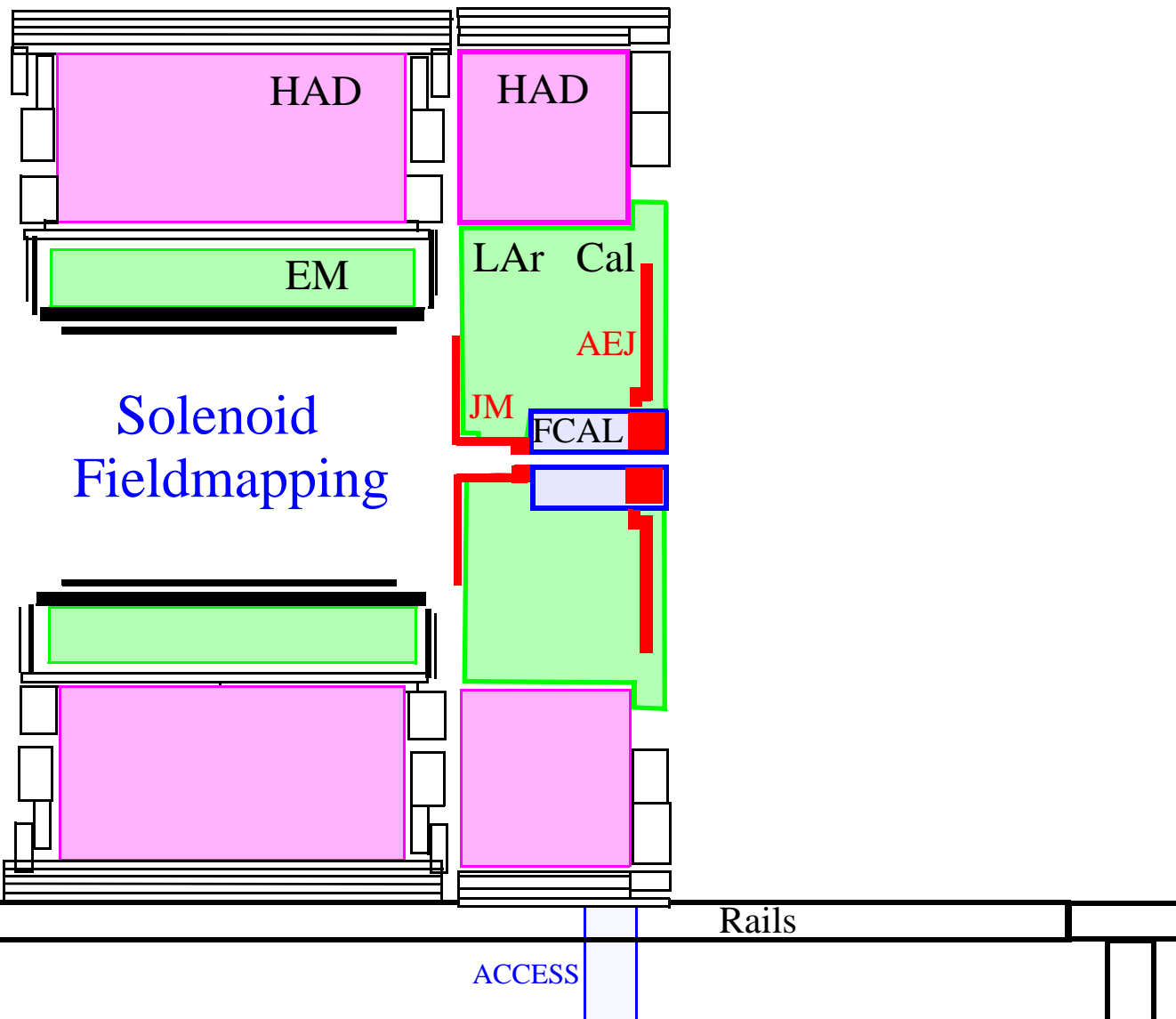



Solenoid
Fieldmapping

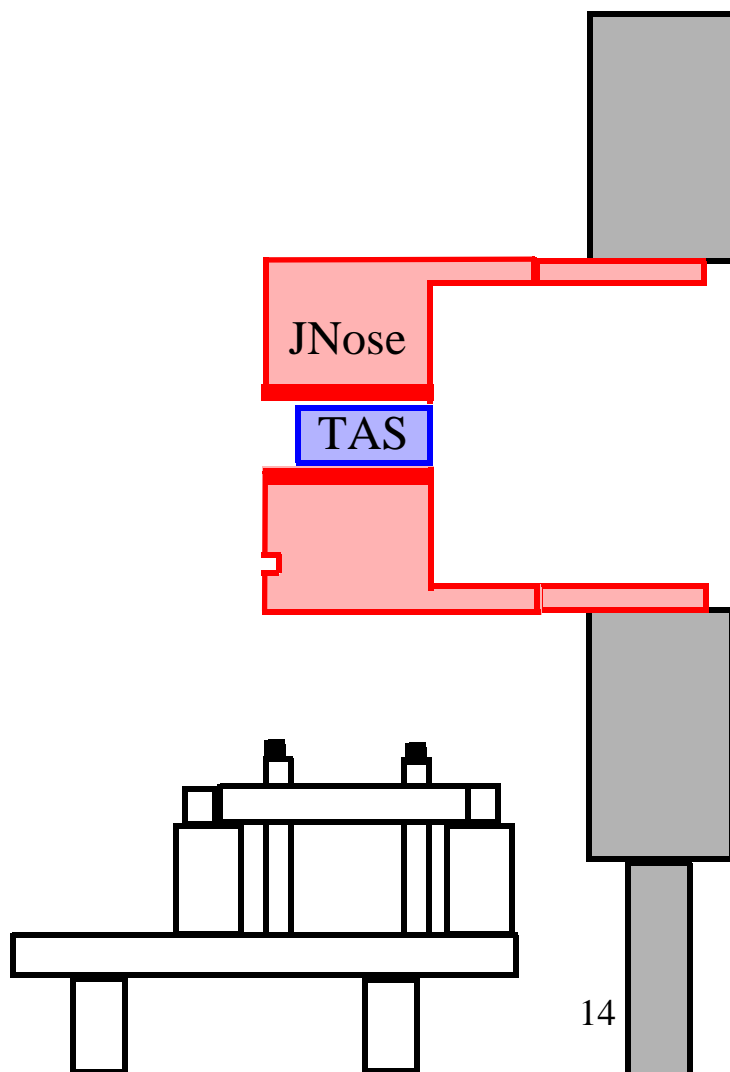

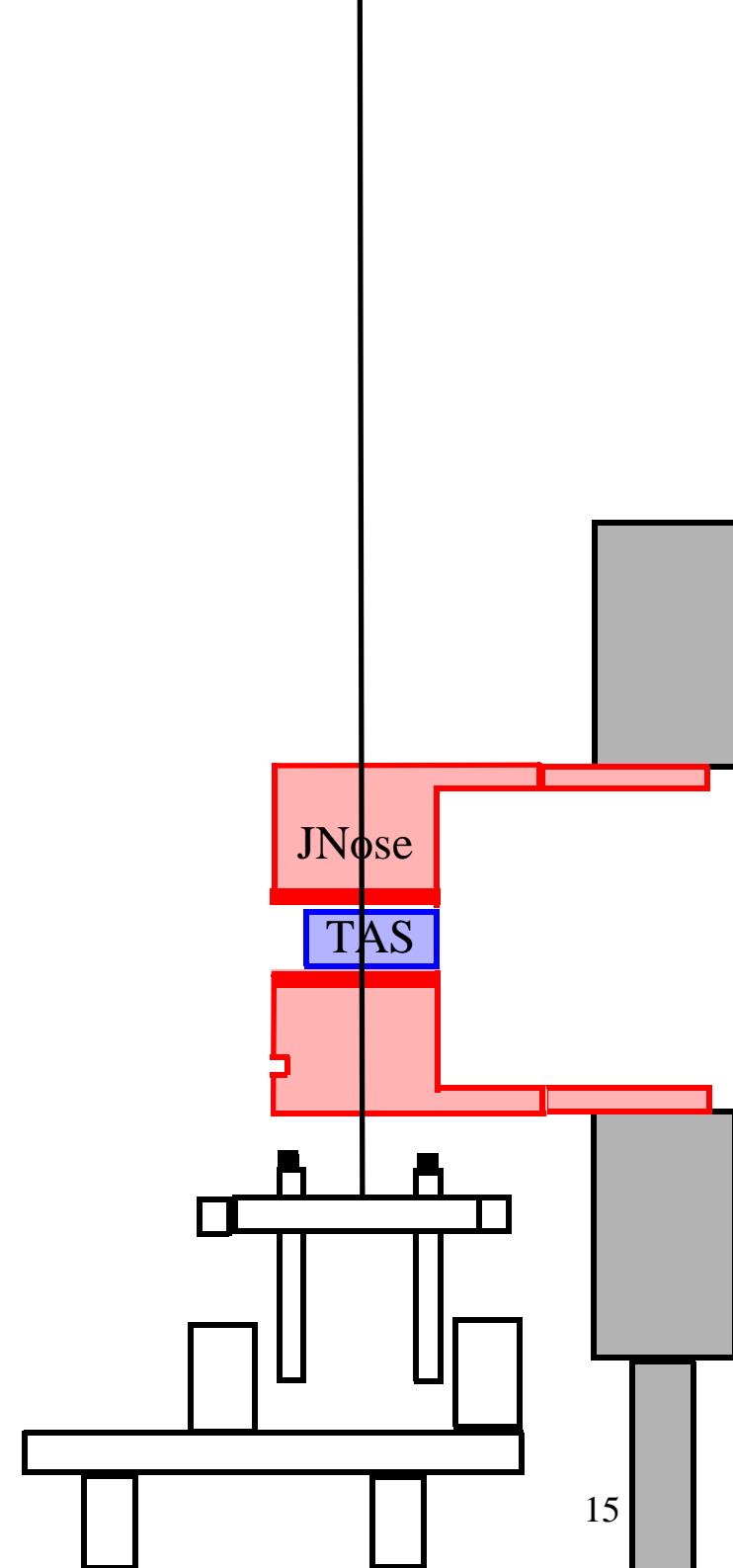

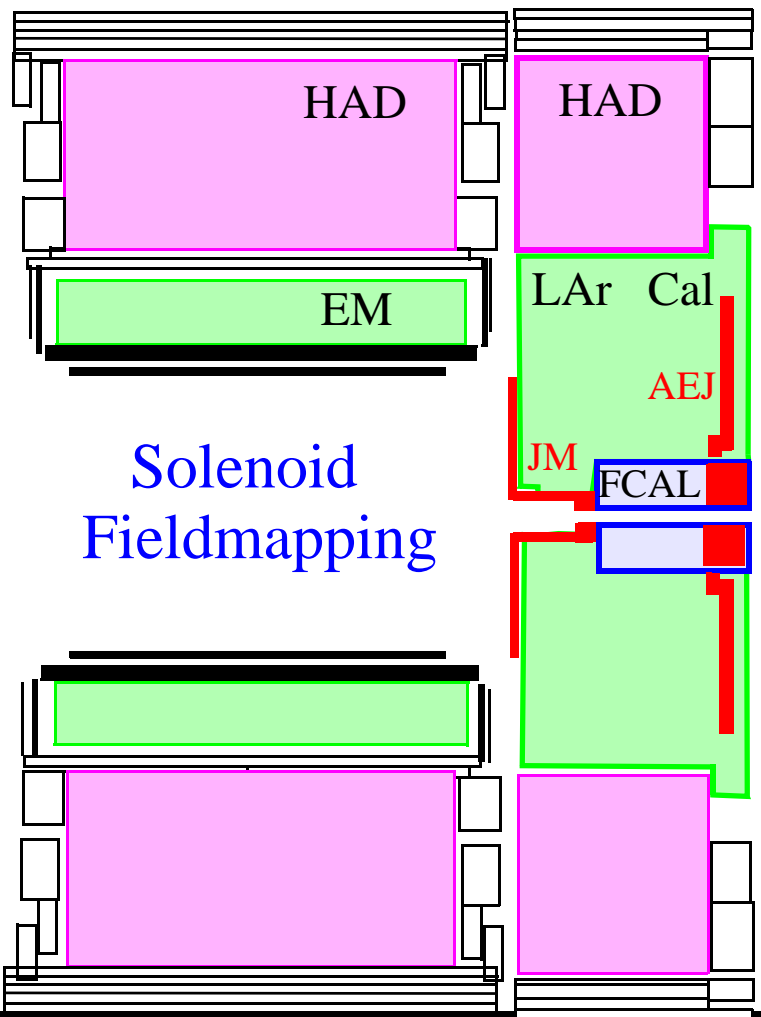

Solenoid
Fieldmapping

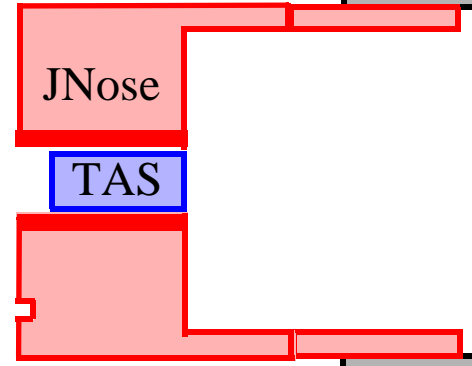

ACCESS

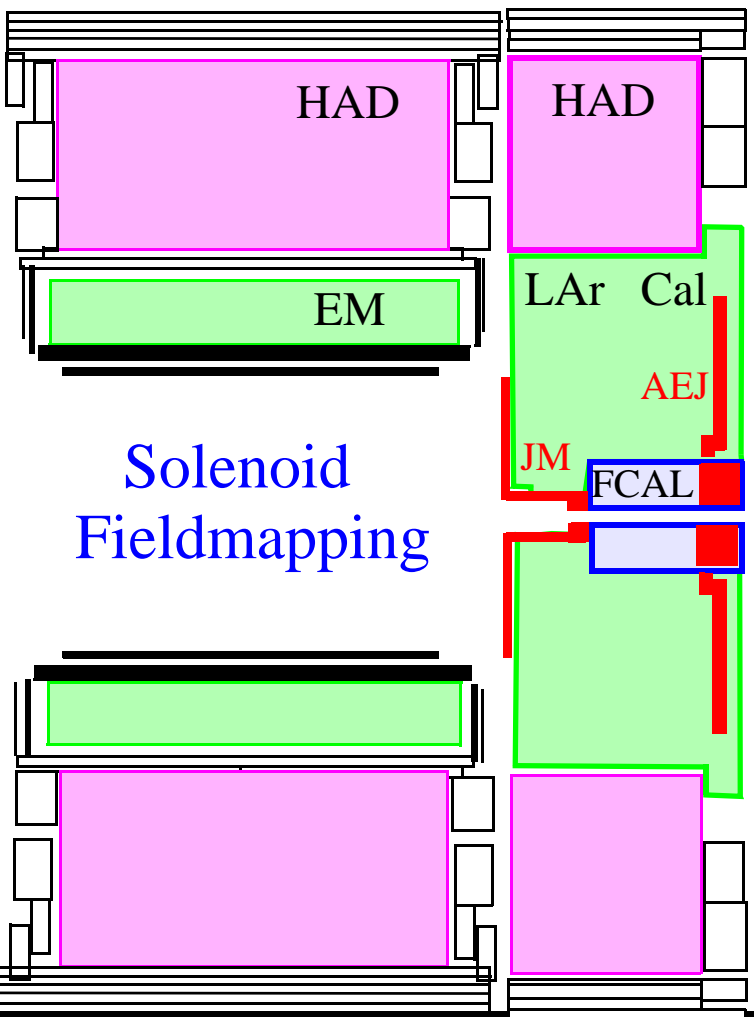

Solenoid
Fieldmapping

Rails

ACCESS

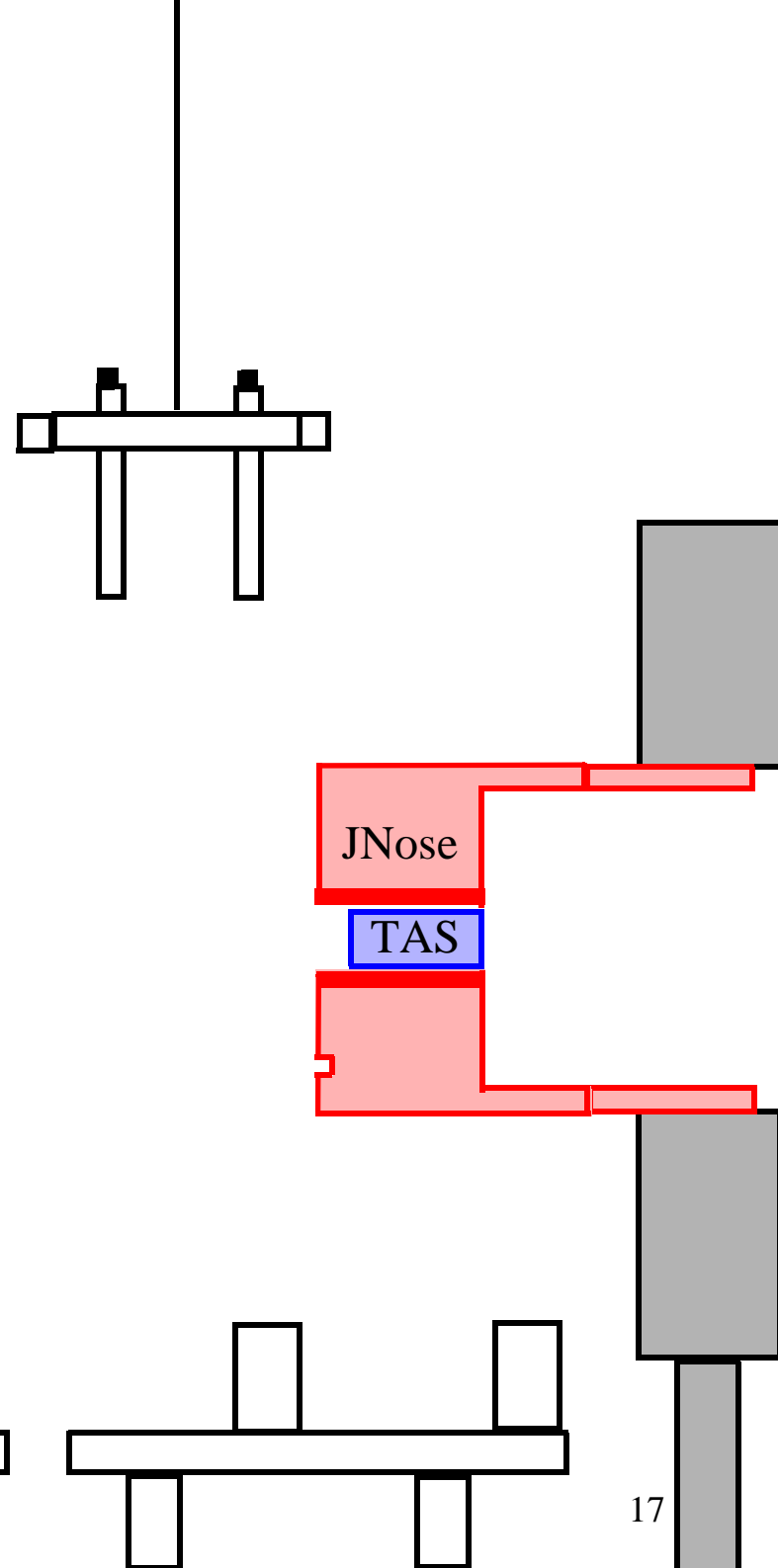



Solenoid
Fieldmapping

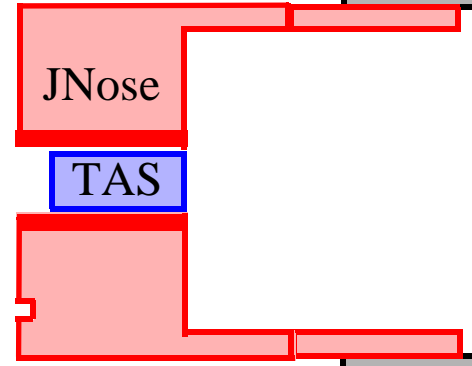
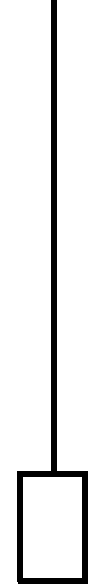

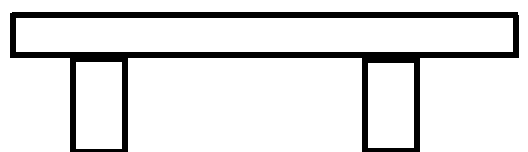
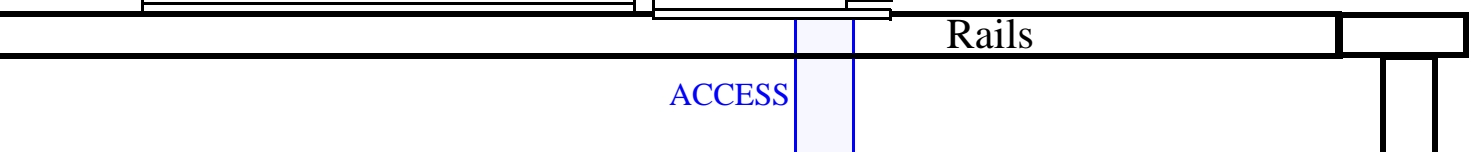
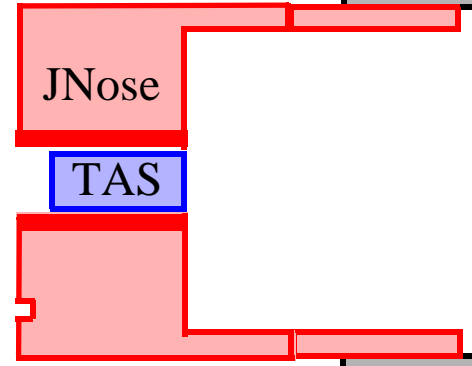
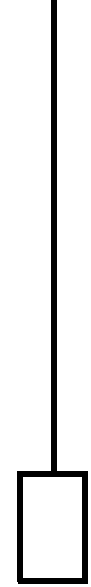
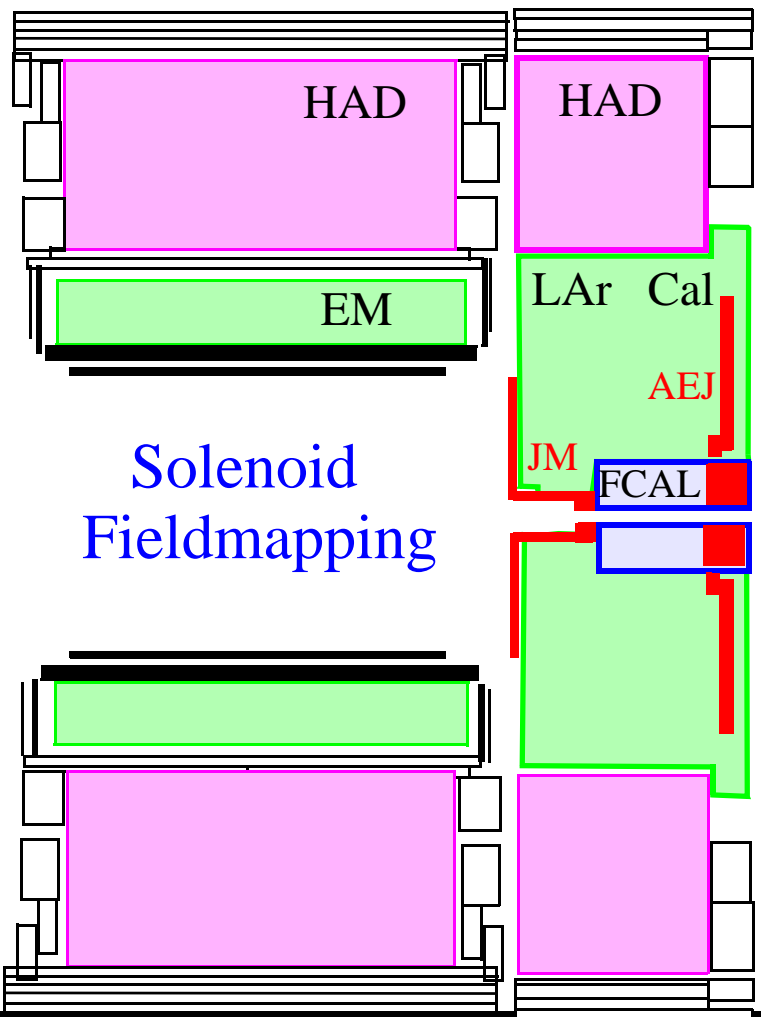

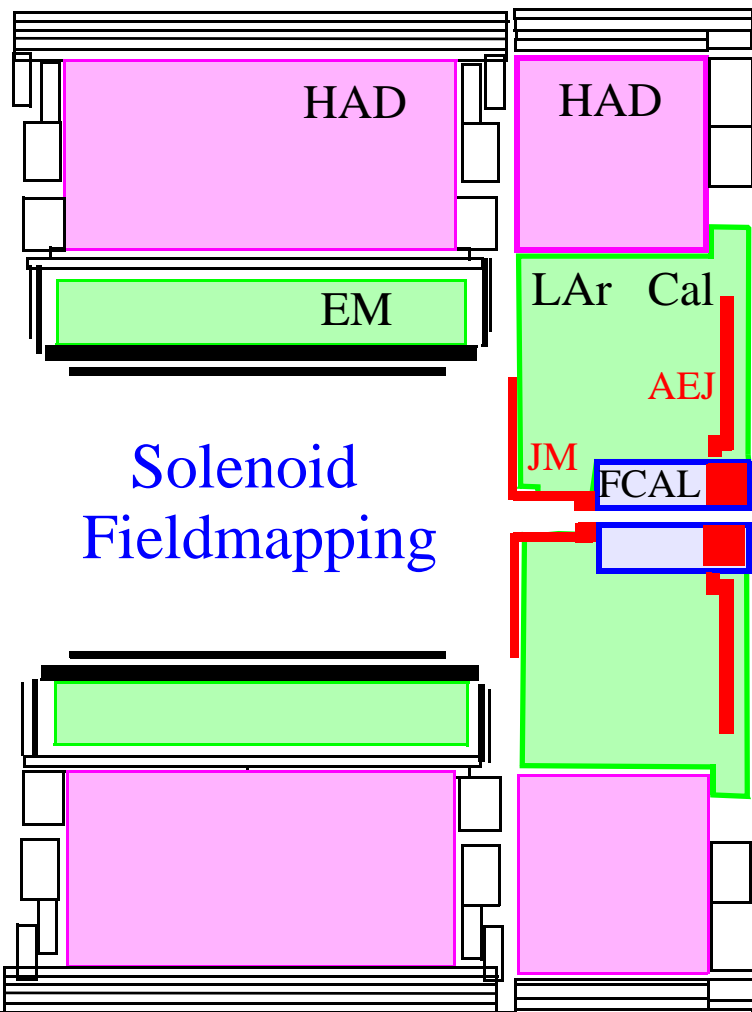

Solenoid
Fieldmapping

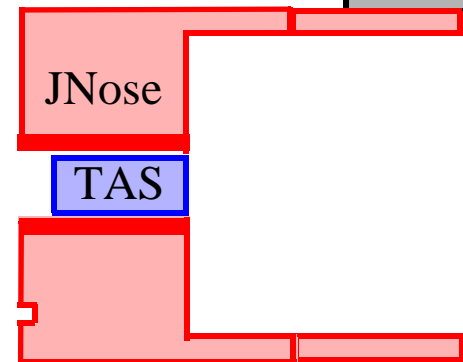

ACCESS

Rails

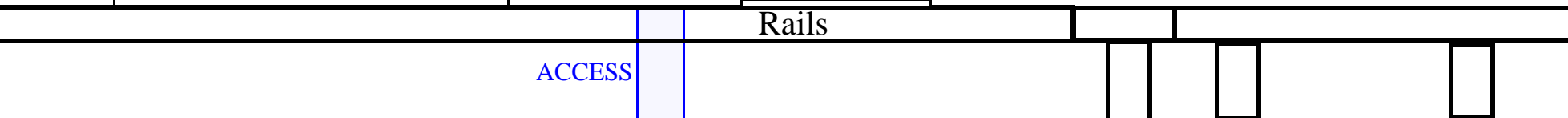
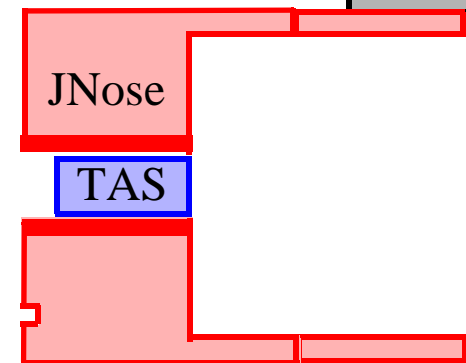
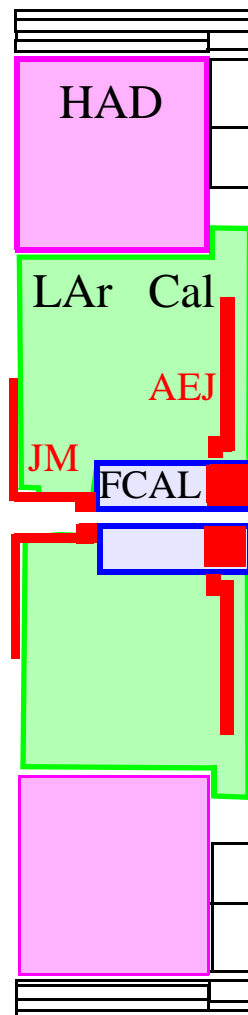
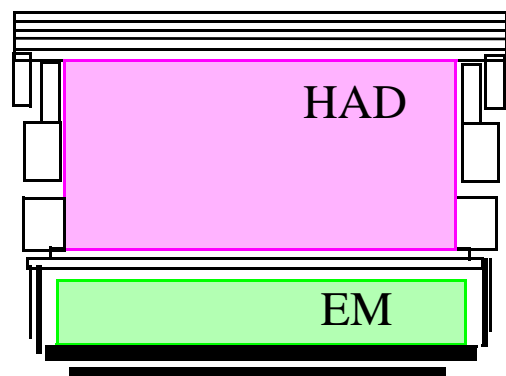

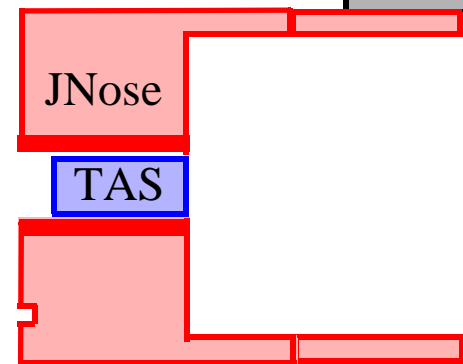
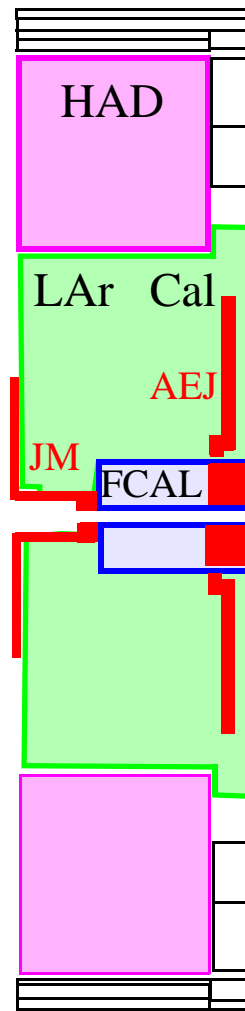
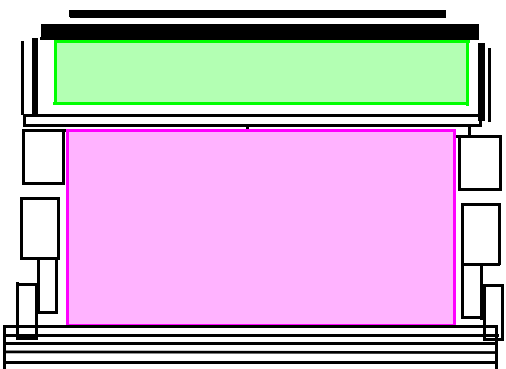

ACCESS

Rails

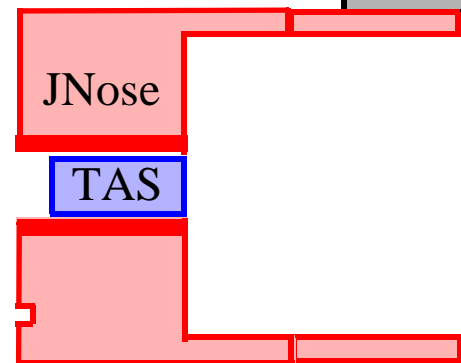
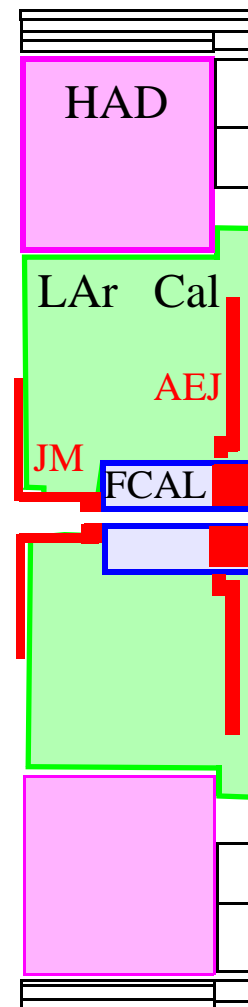
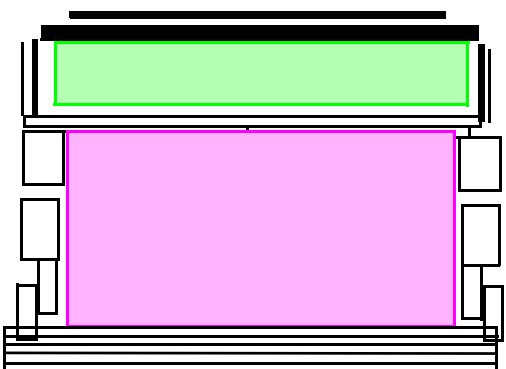
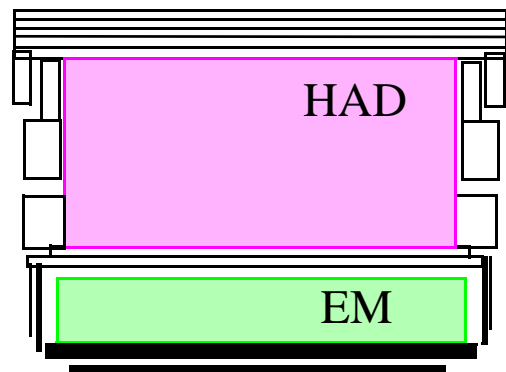

Rails

ACCESS

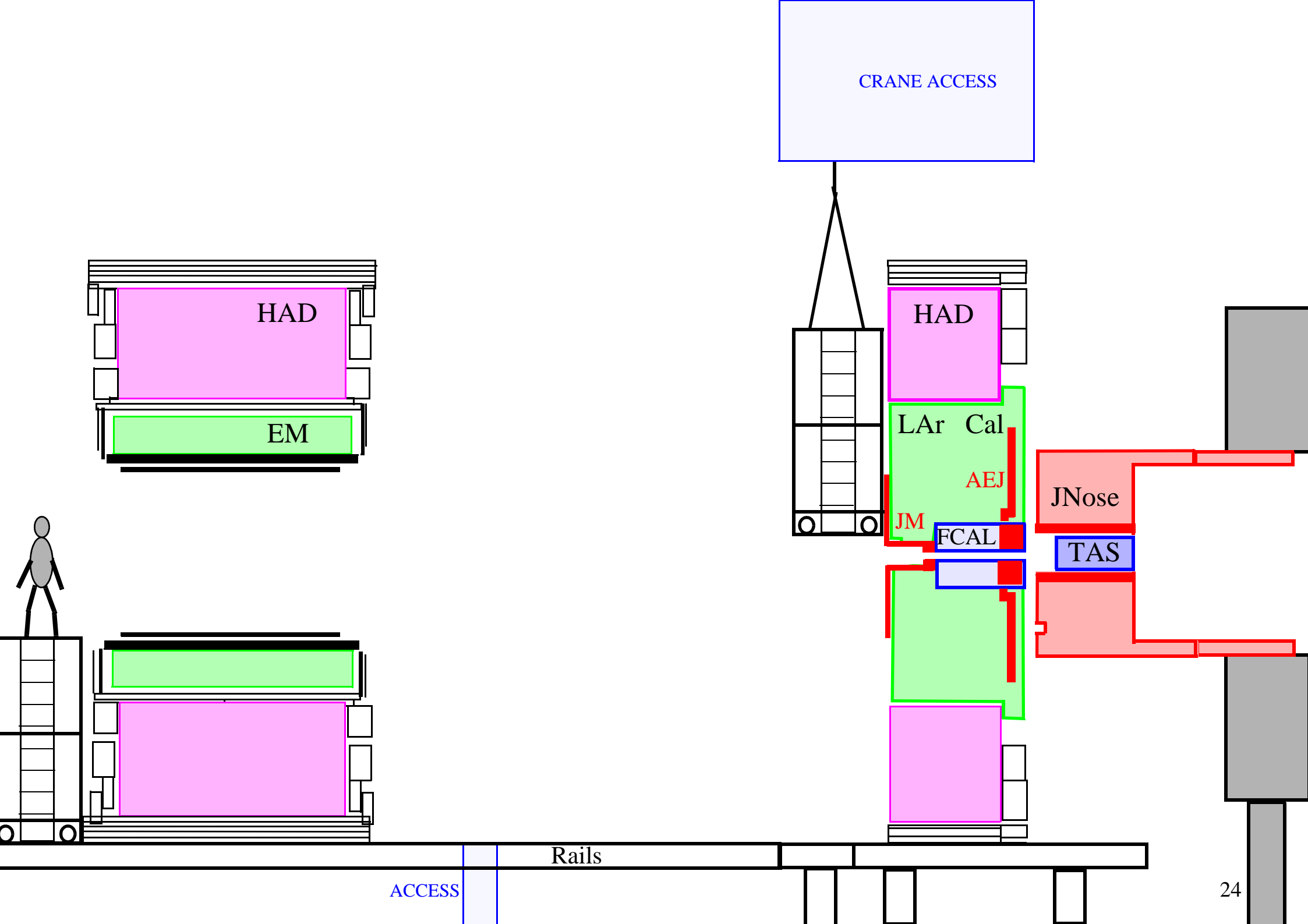

CRANE ACCESS

HAD

EM

HAD

LAr Cal

AEJ

JM

FCAL

JNose

TAS

Rails

ACCESS

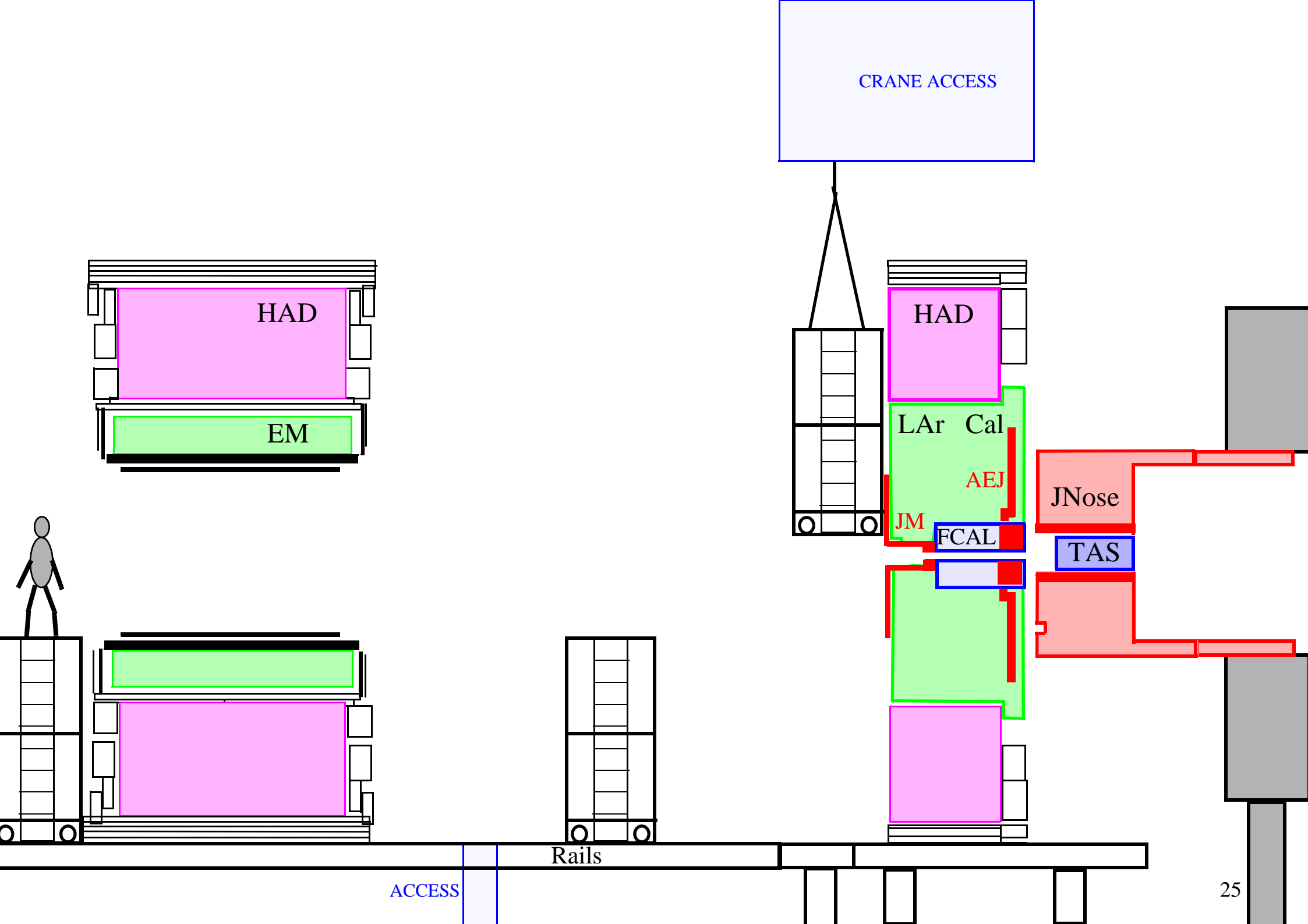

CRANE ACCESS

HAD

EM

HAD

LAr Cal

AEJ

JM

FCAL

JNose

TAS

Rails

ACCESS

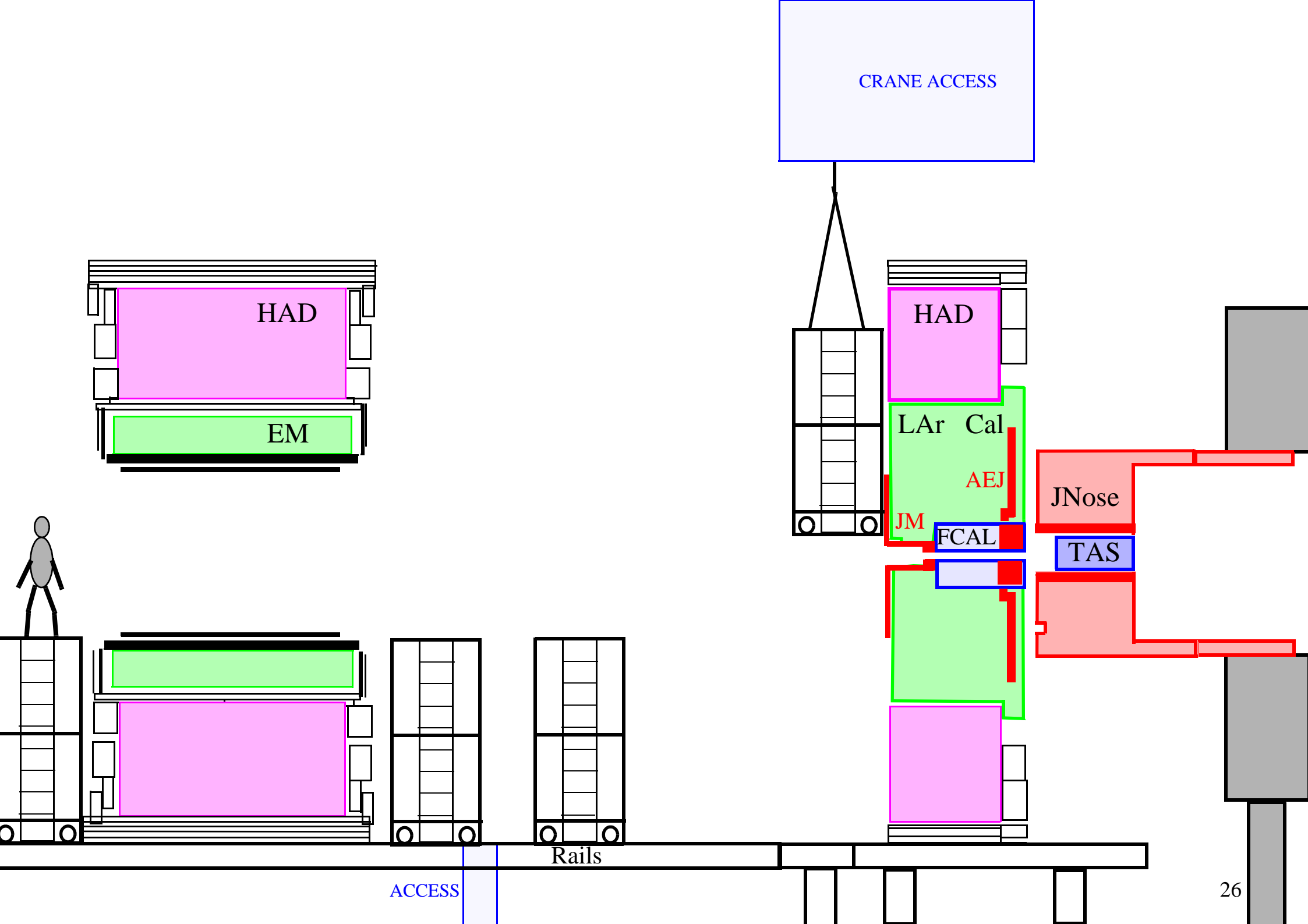

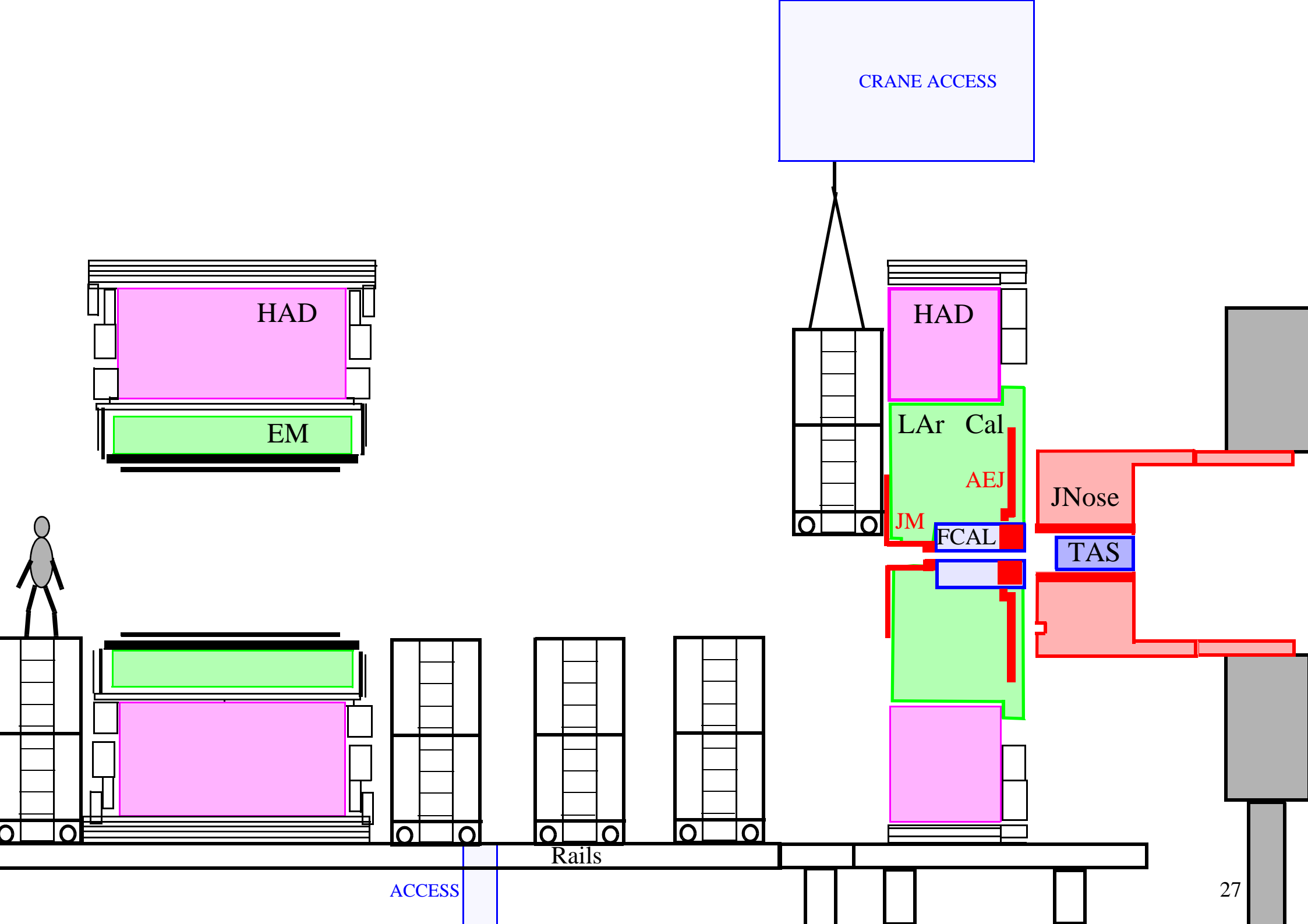

CRANE ACCESS

HAD

EM

HAD

LAr Cal

AEJ

JM

FCAL

JNose

TAS

Rails

ACCESS

July 2006

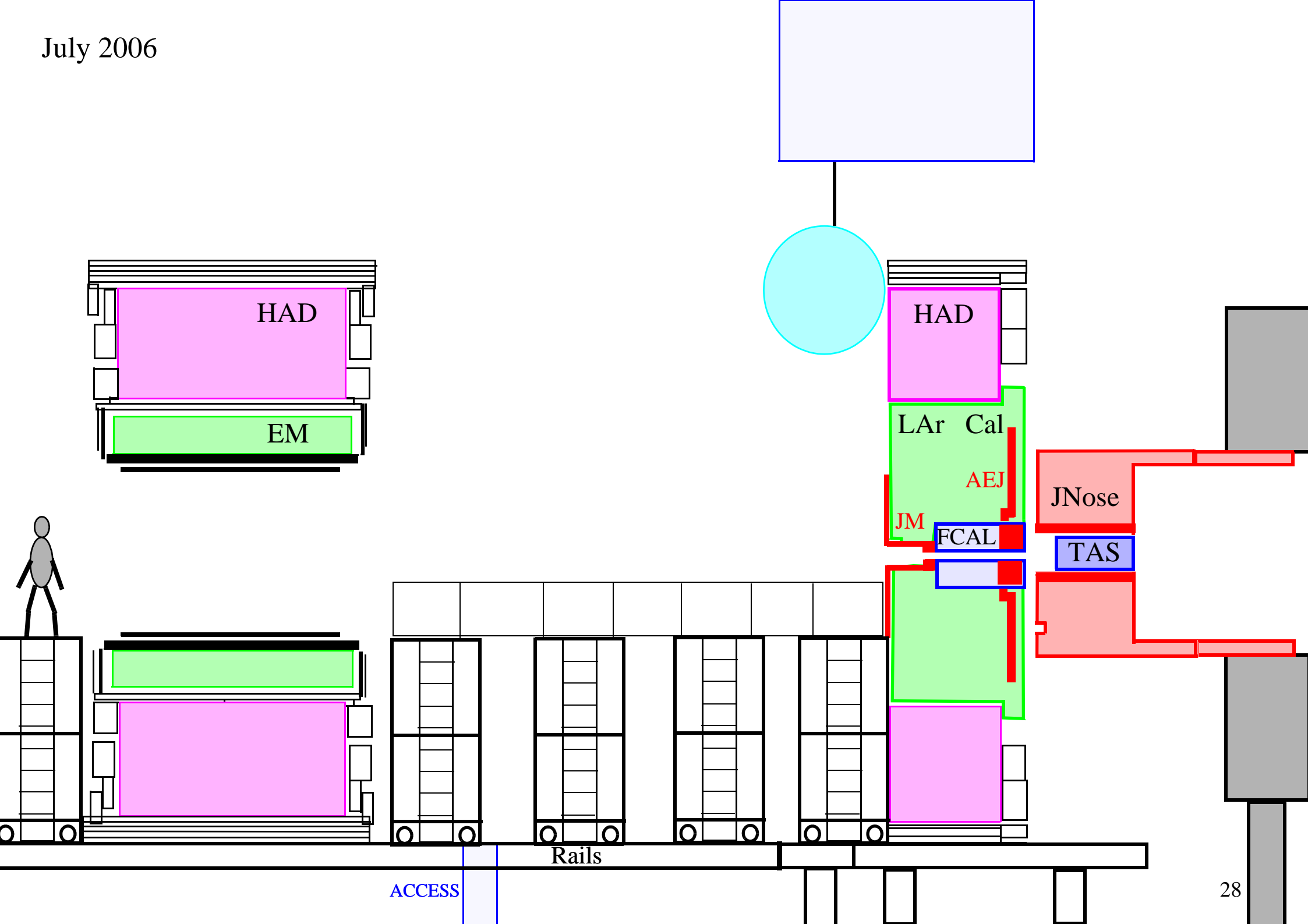

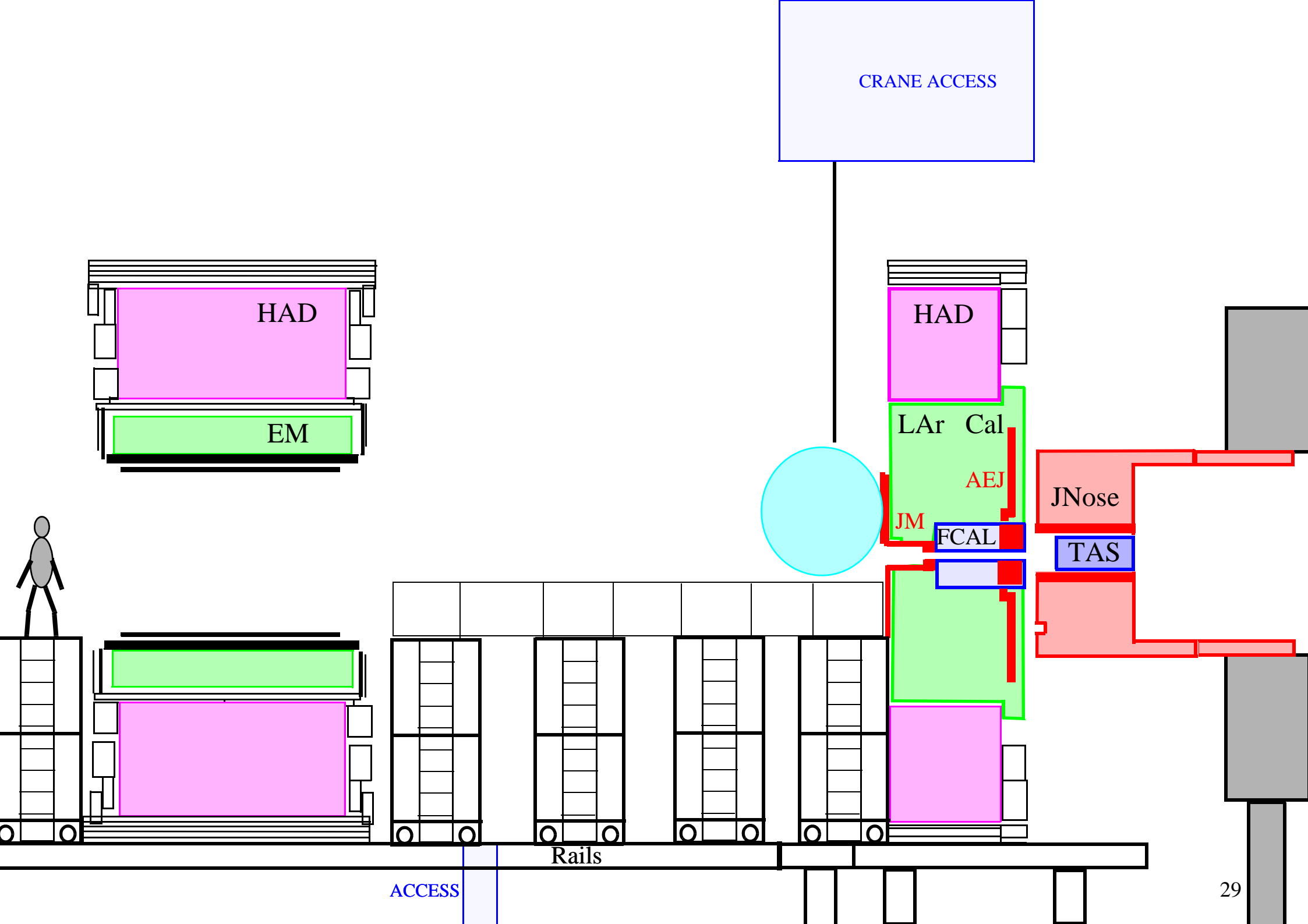

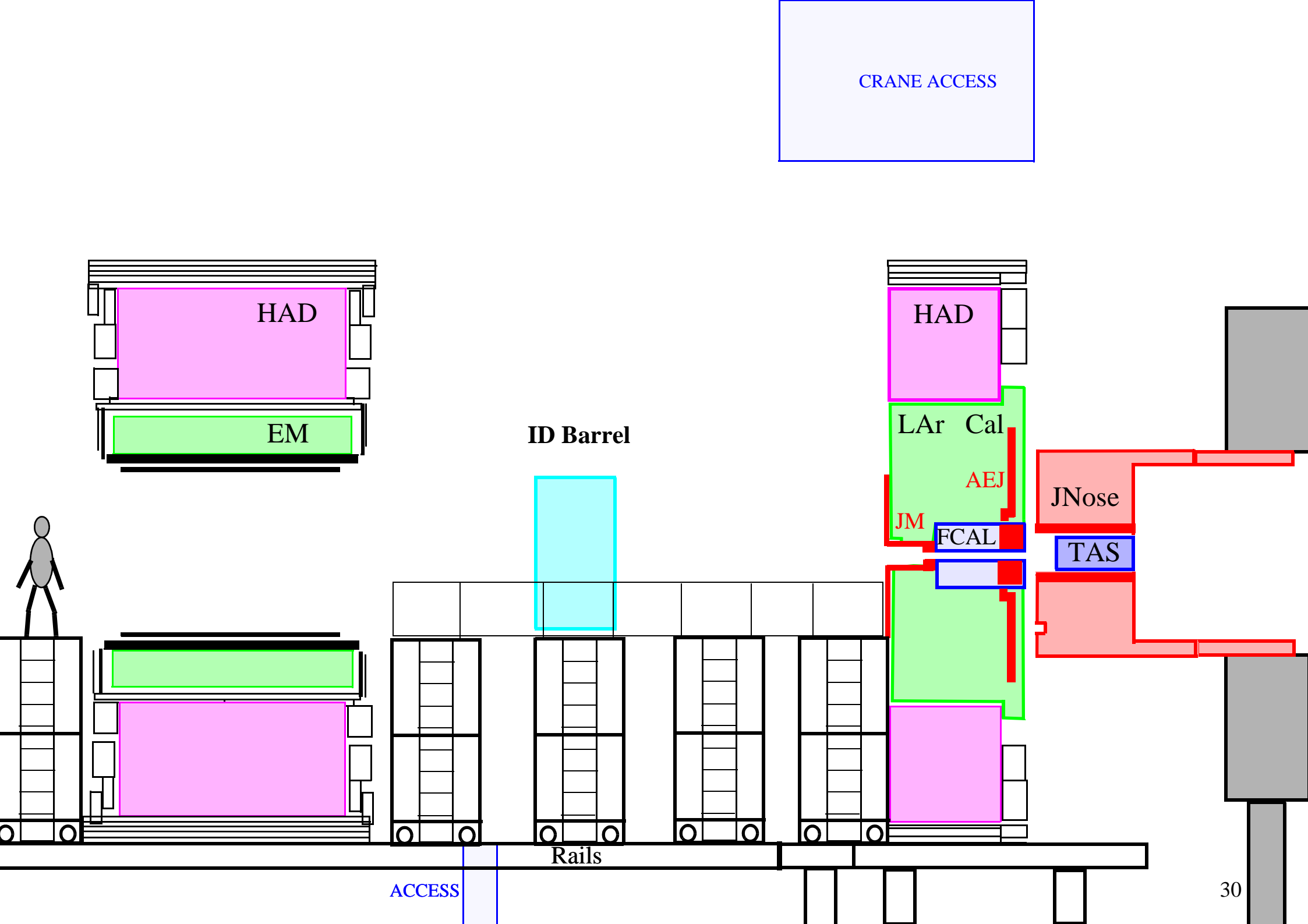

ACCESS

Rails



CRANE ACCESS

HAD

EM

HAD

LAr Cal

AEJ

JM

FCAL

JNose

TAS

Rails

ACCESS

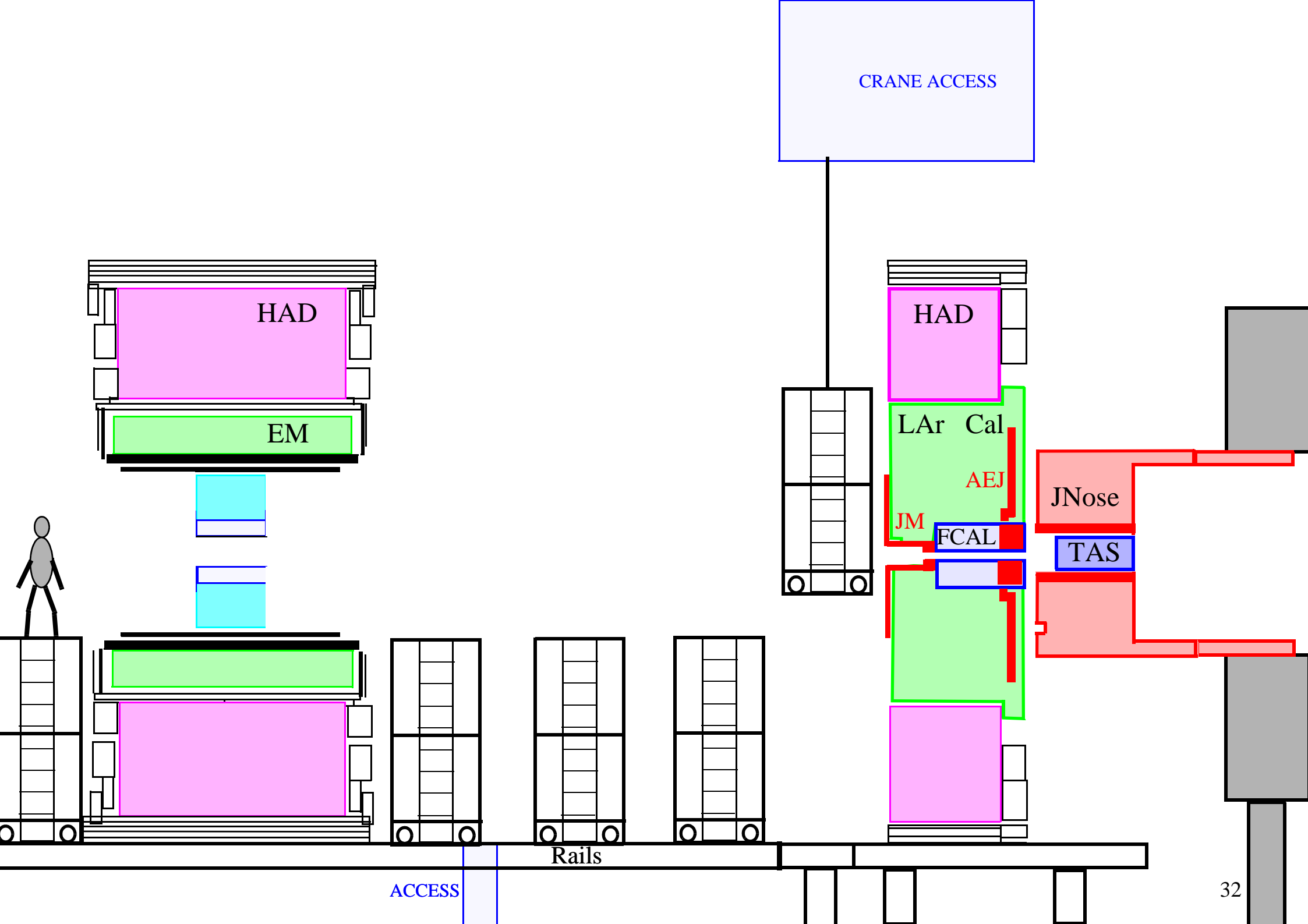

ACCESS

Rails

CRANE ACCESS

HAD

EM

HAD

LAr Cal

AEJ

JM

FCAL

JNose

TAS

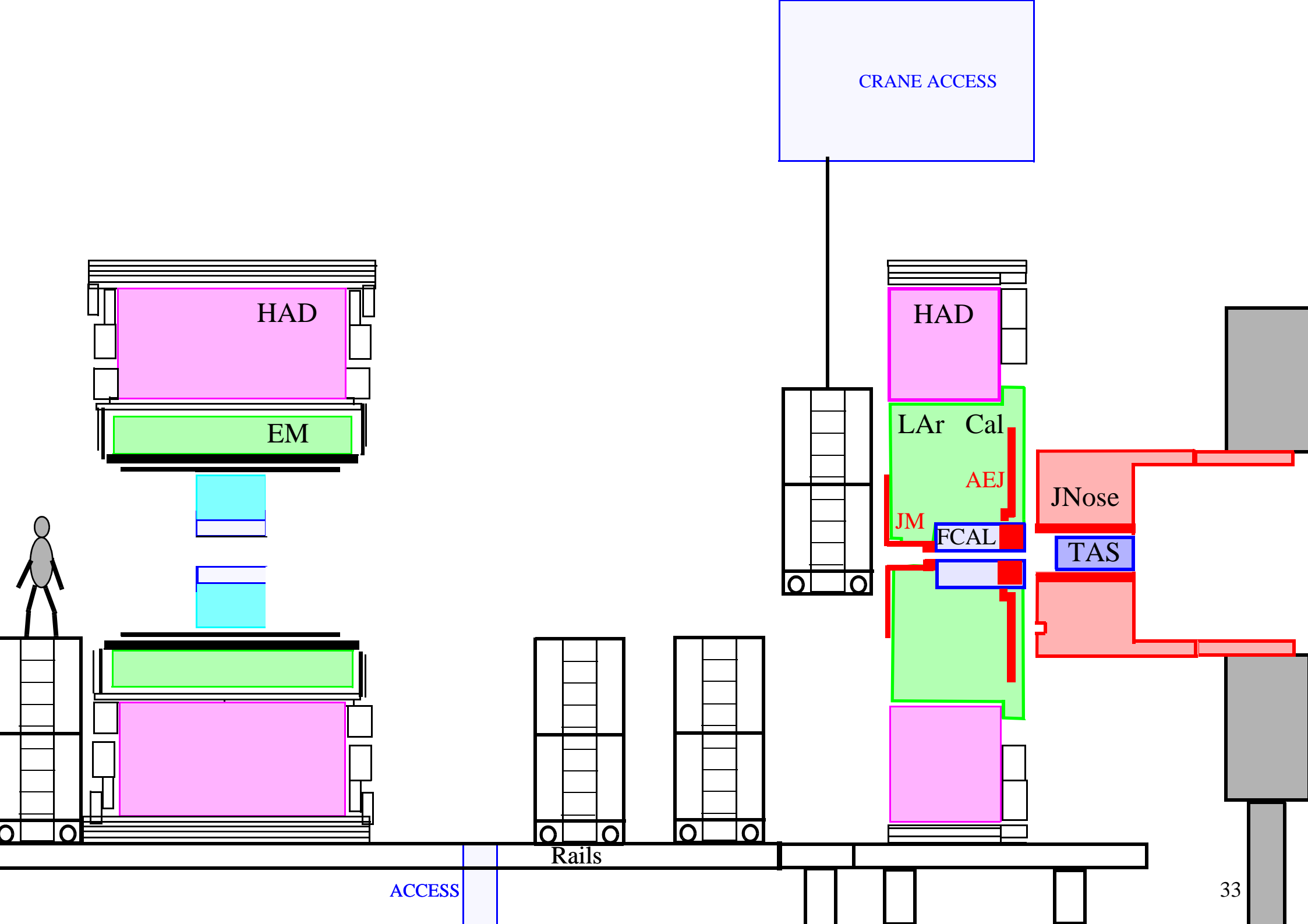

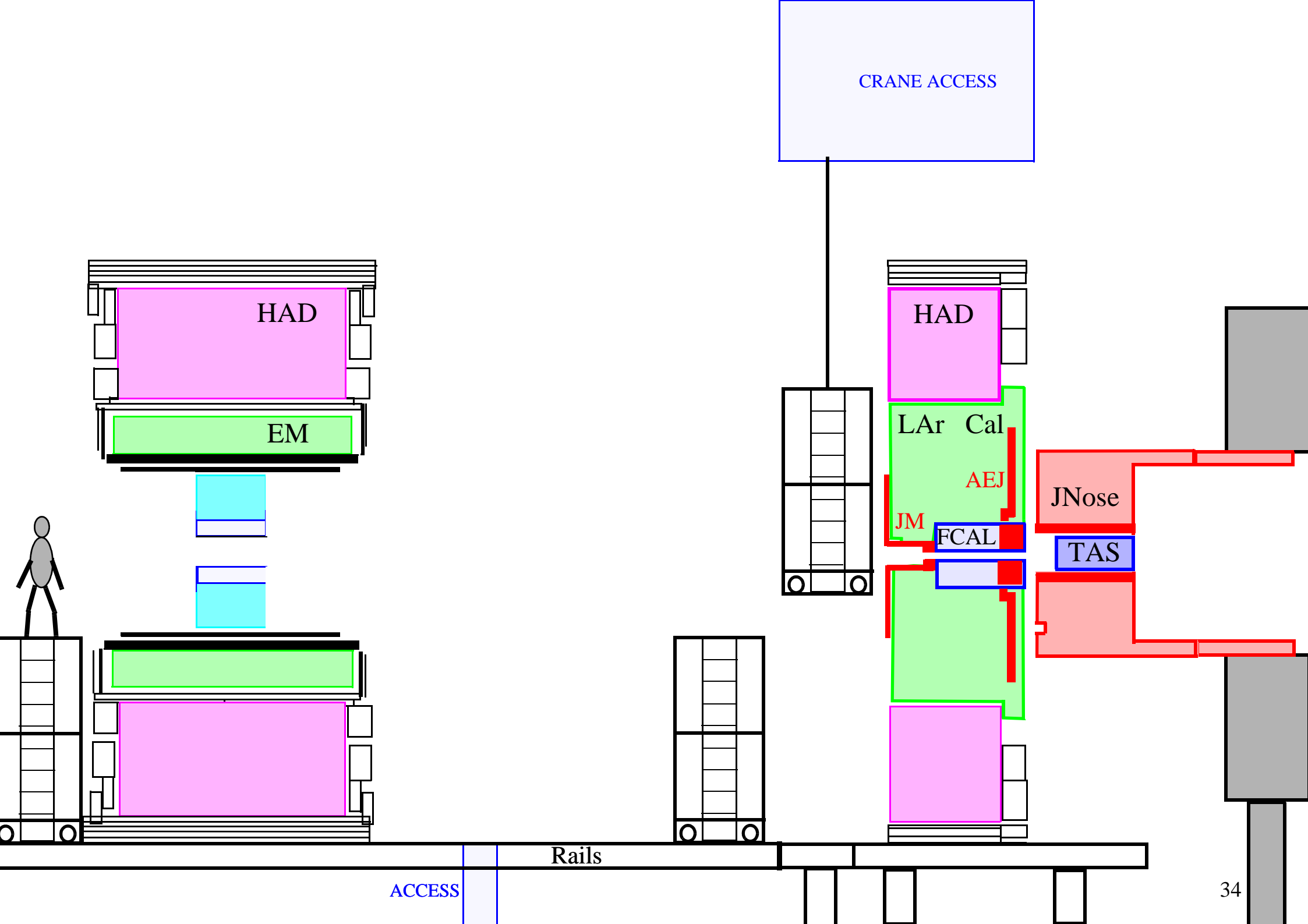

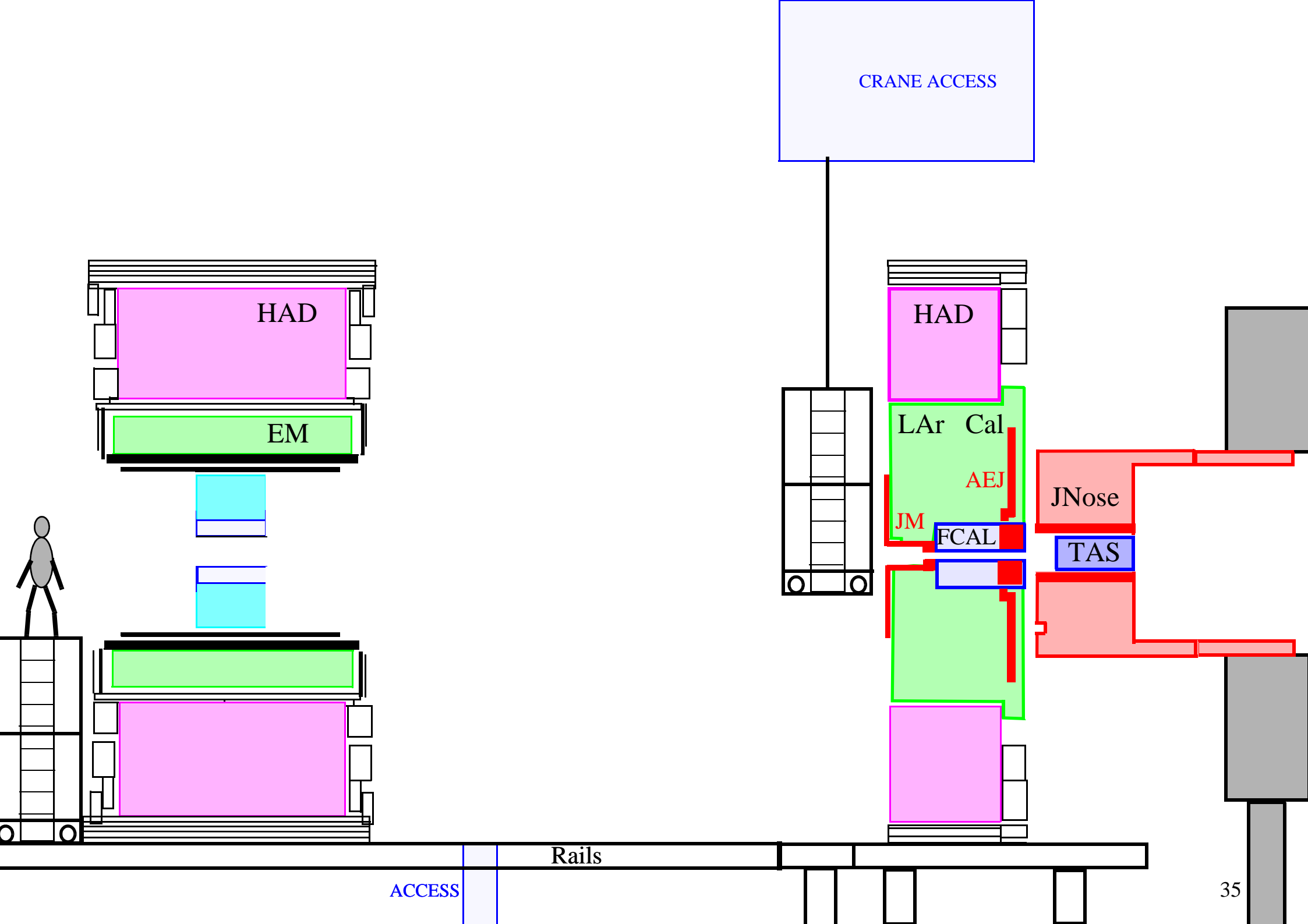

August 2006

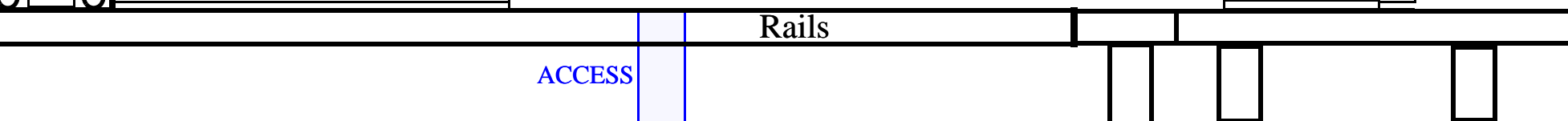
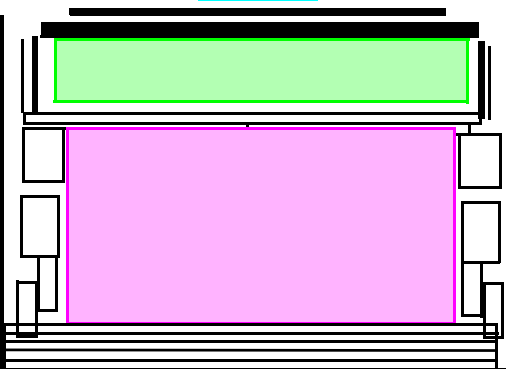
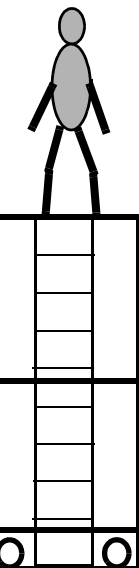
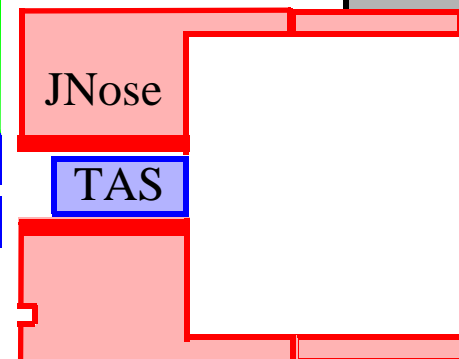
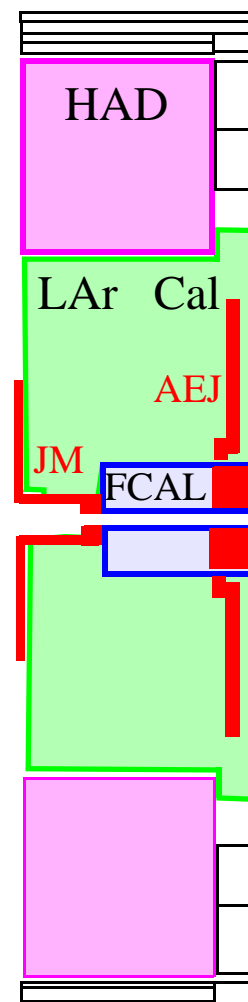
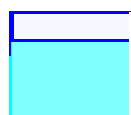
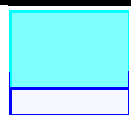
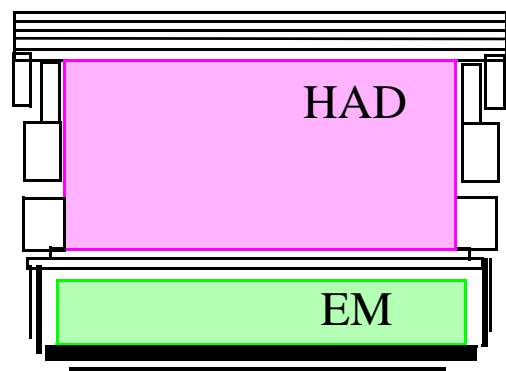

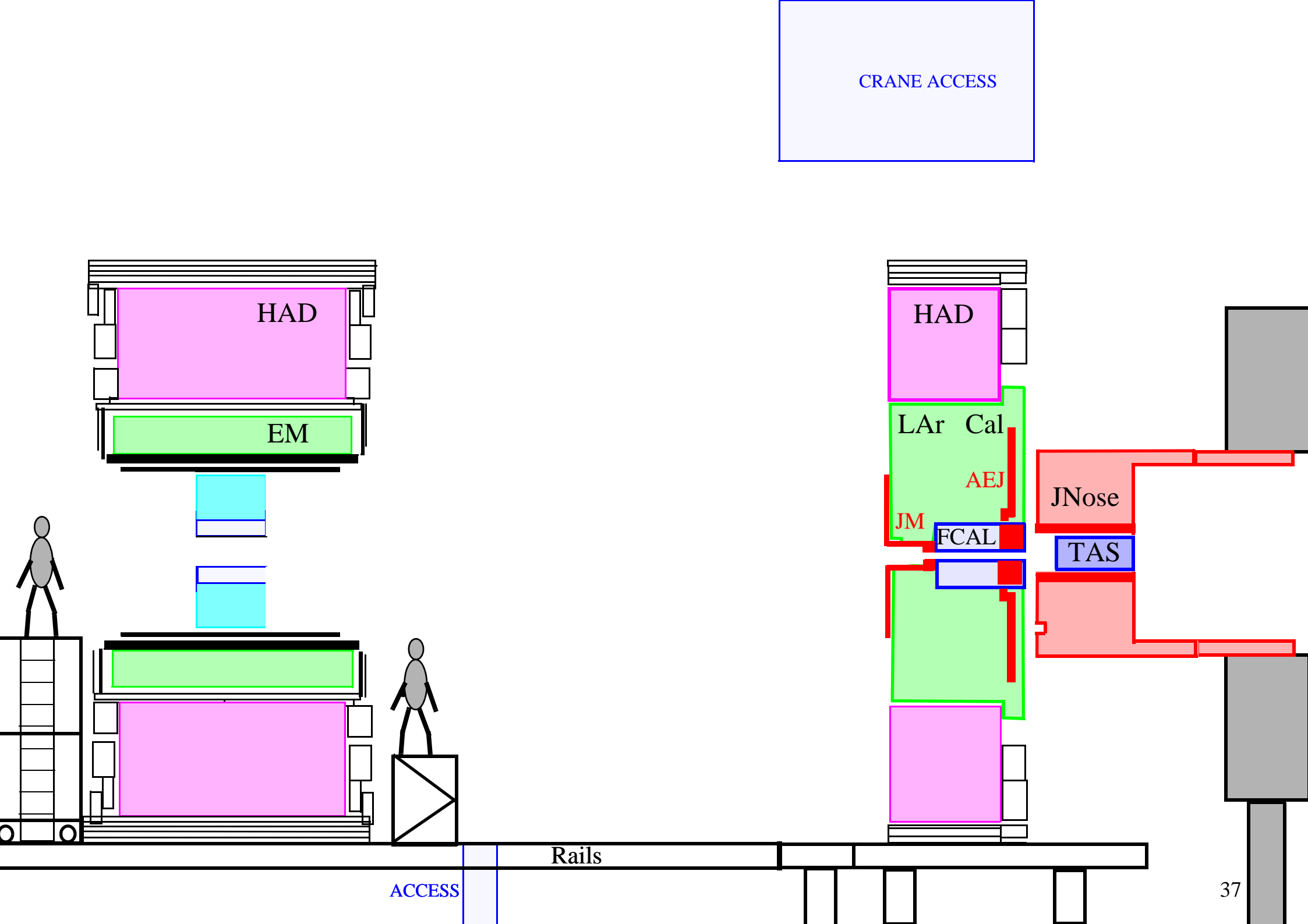

CRANE ACCESS

HAD

EM

HAD

LAr Cal

AEJ

JNose

FCAL

TAS

JM

Rails

ACCESS

CRANE ACCESS

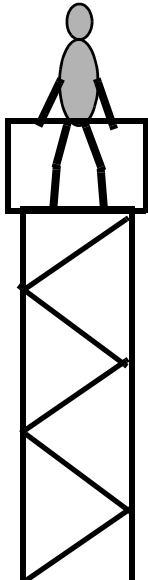
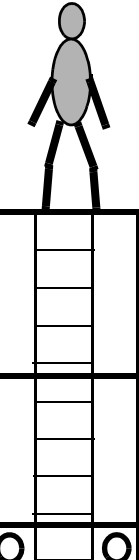
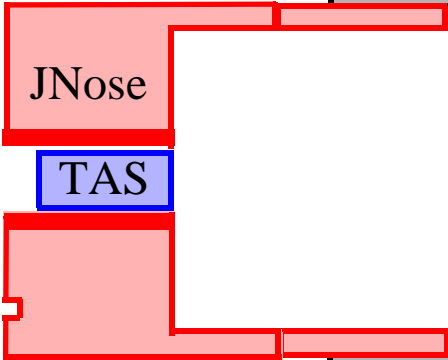
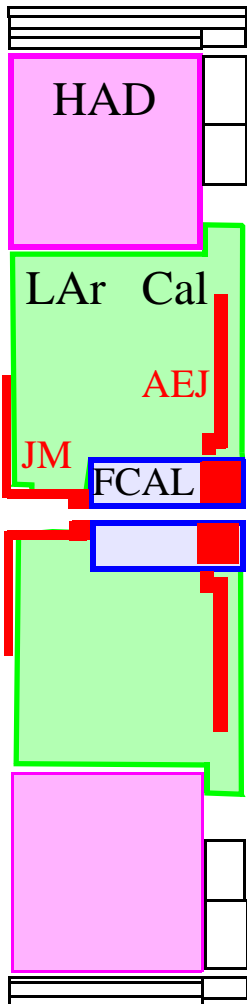
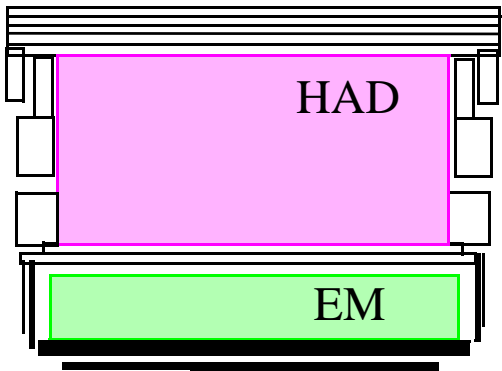

Rails

ACCESS

CRANE ACCESS

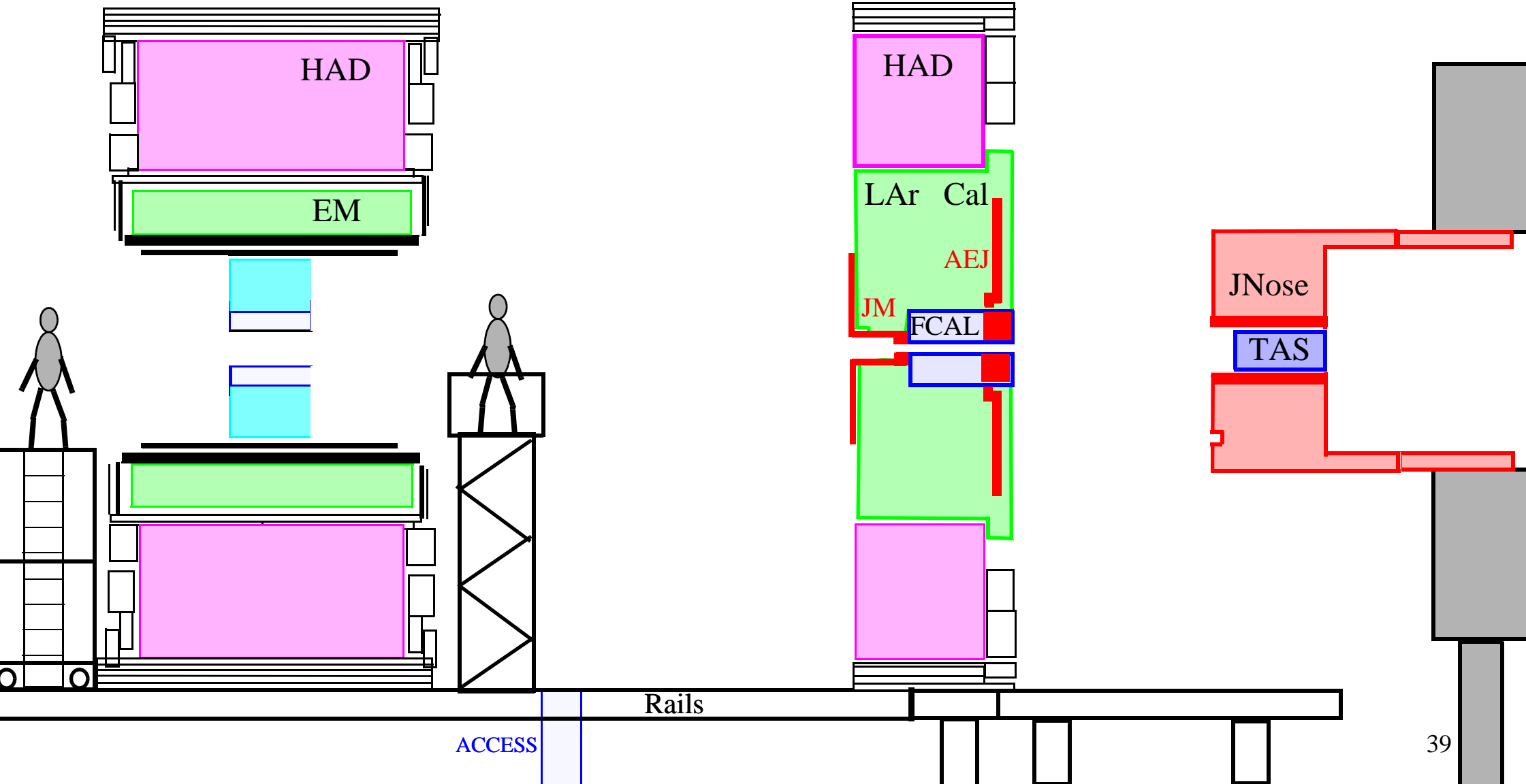

CRANE ACCESS

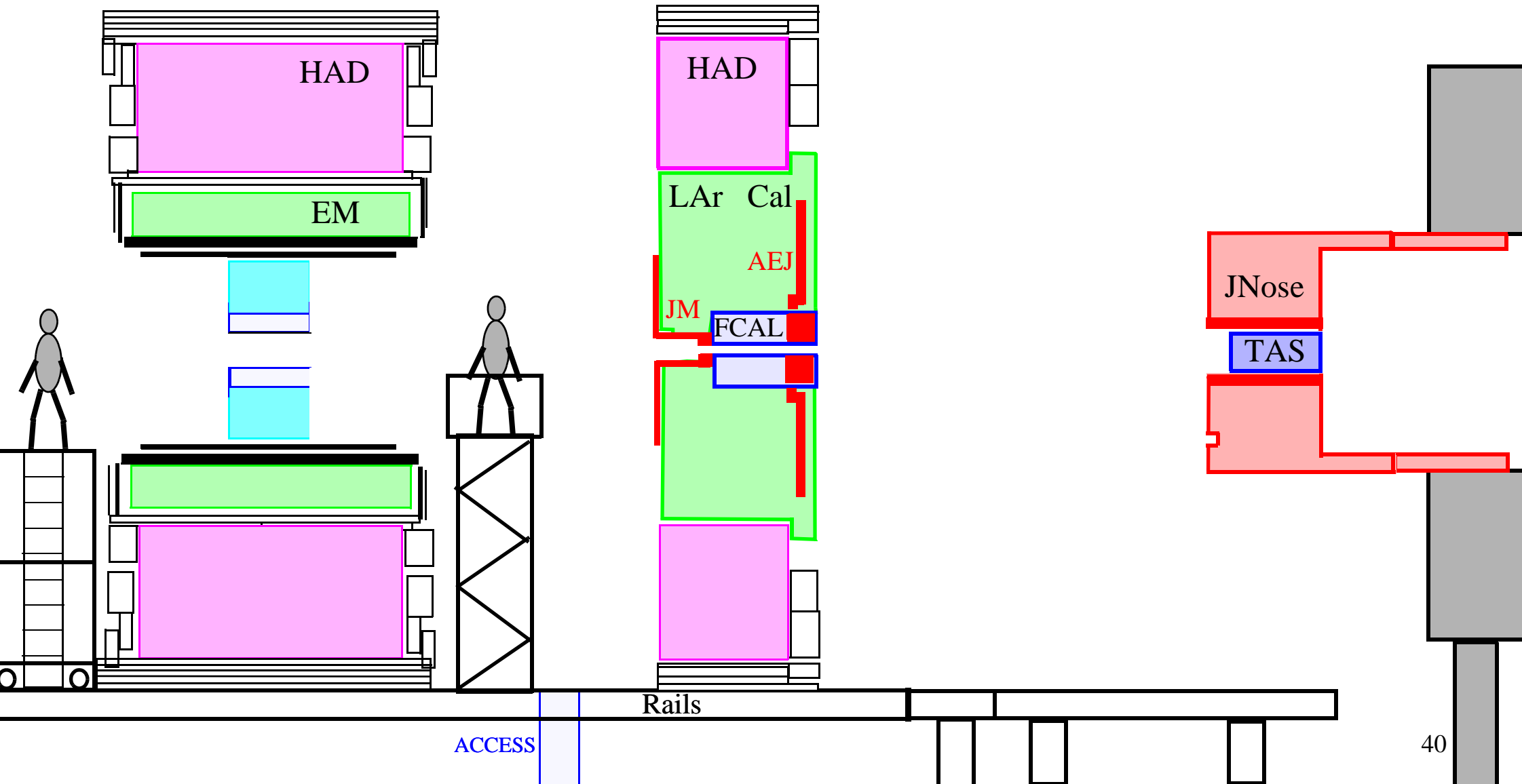

No access by the lift !

CRANE ACCESS

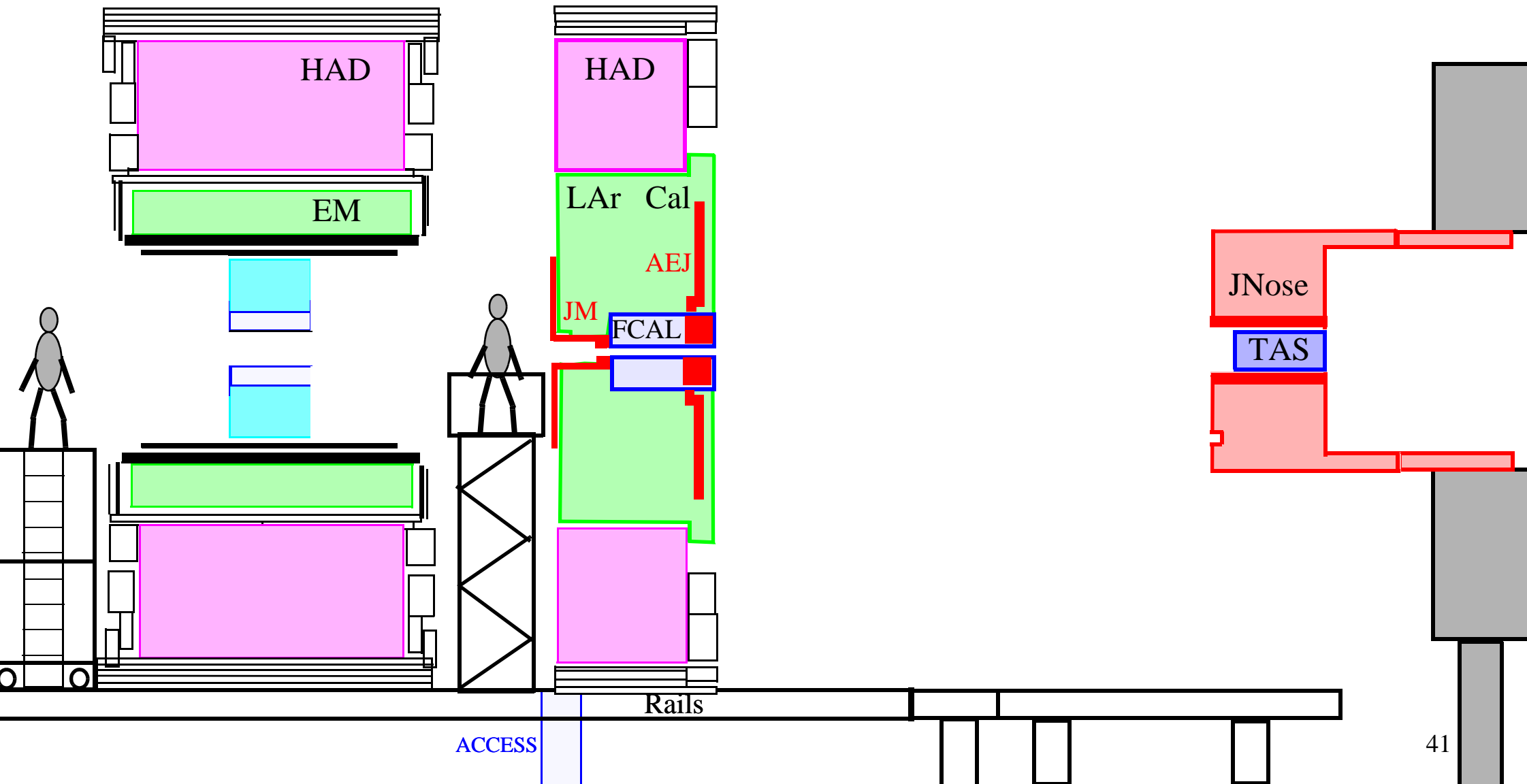

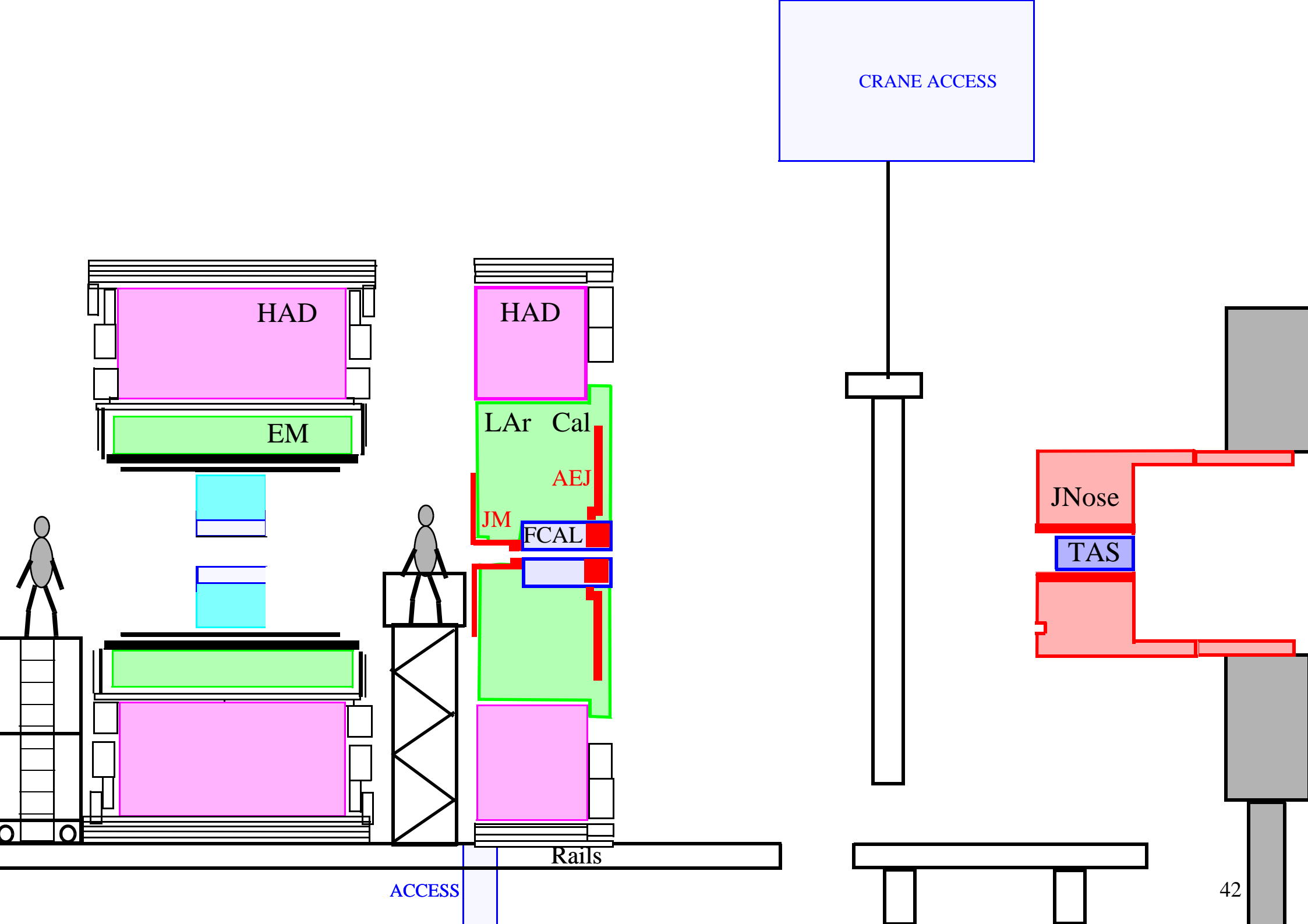

HAD

EM

HAD

LAr Cal

AEJ

JM

FCAL

CRANE ACCESS

JNose

TAS

Rails

ACCESS

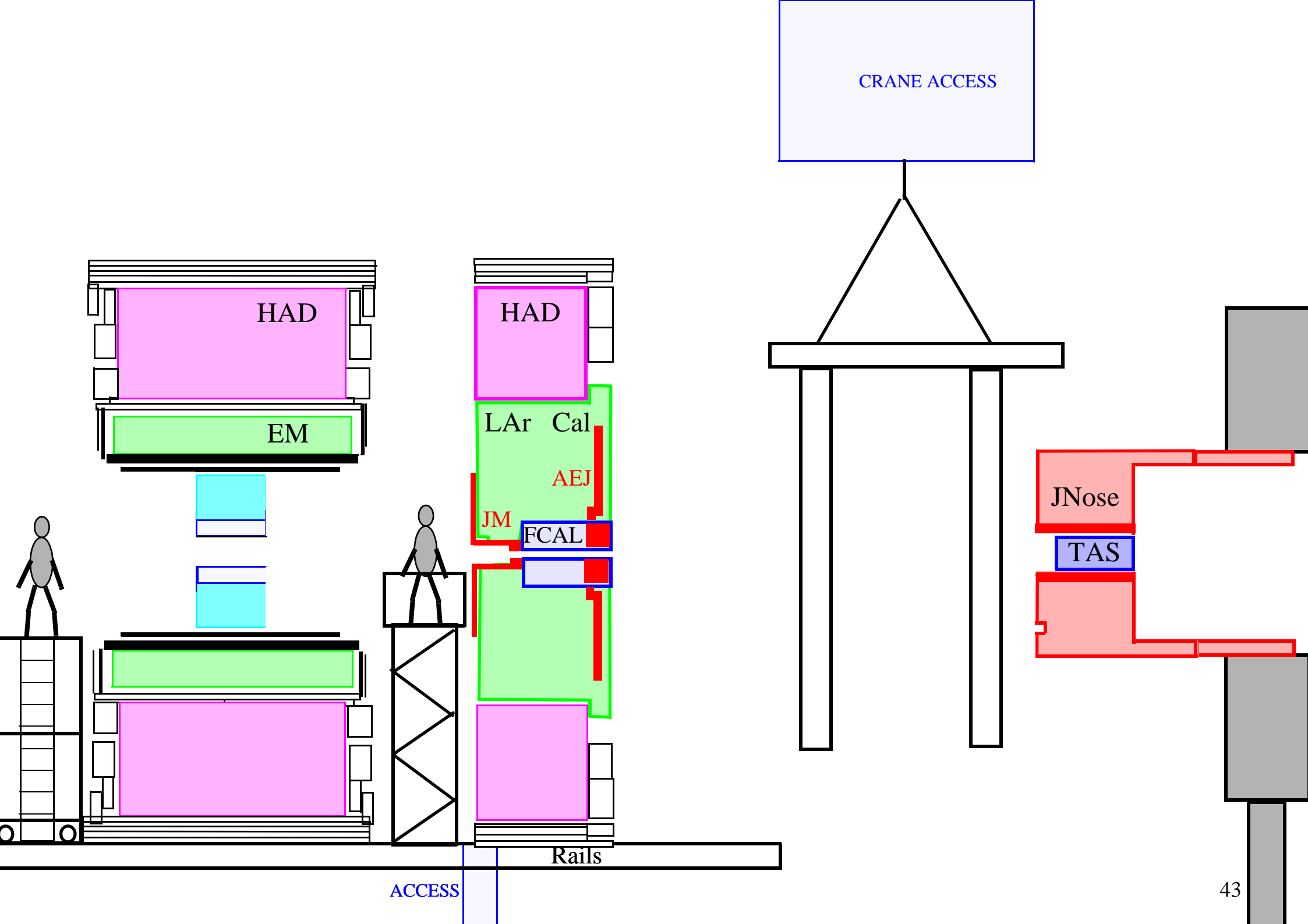

CRANE ACCESS

HAD

EM

HAD

LAr Cal

AEJ

JM

FCAL

JNose

TAS

Rails

ACCESS

CRANE ACCESS

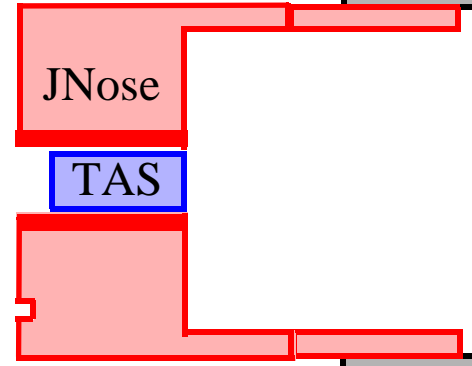
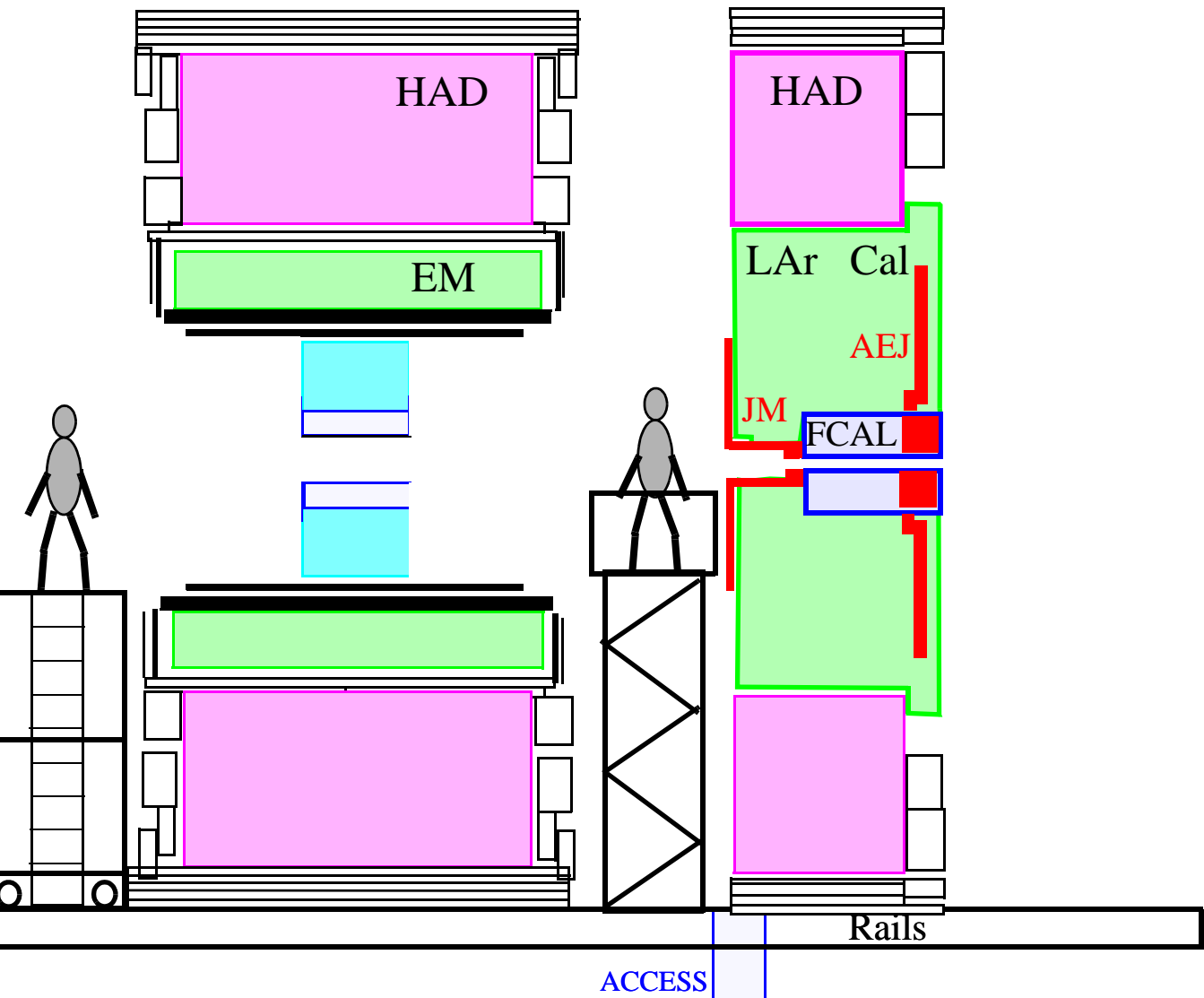

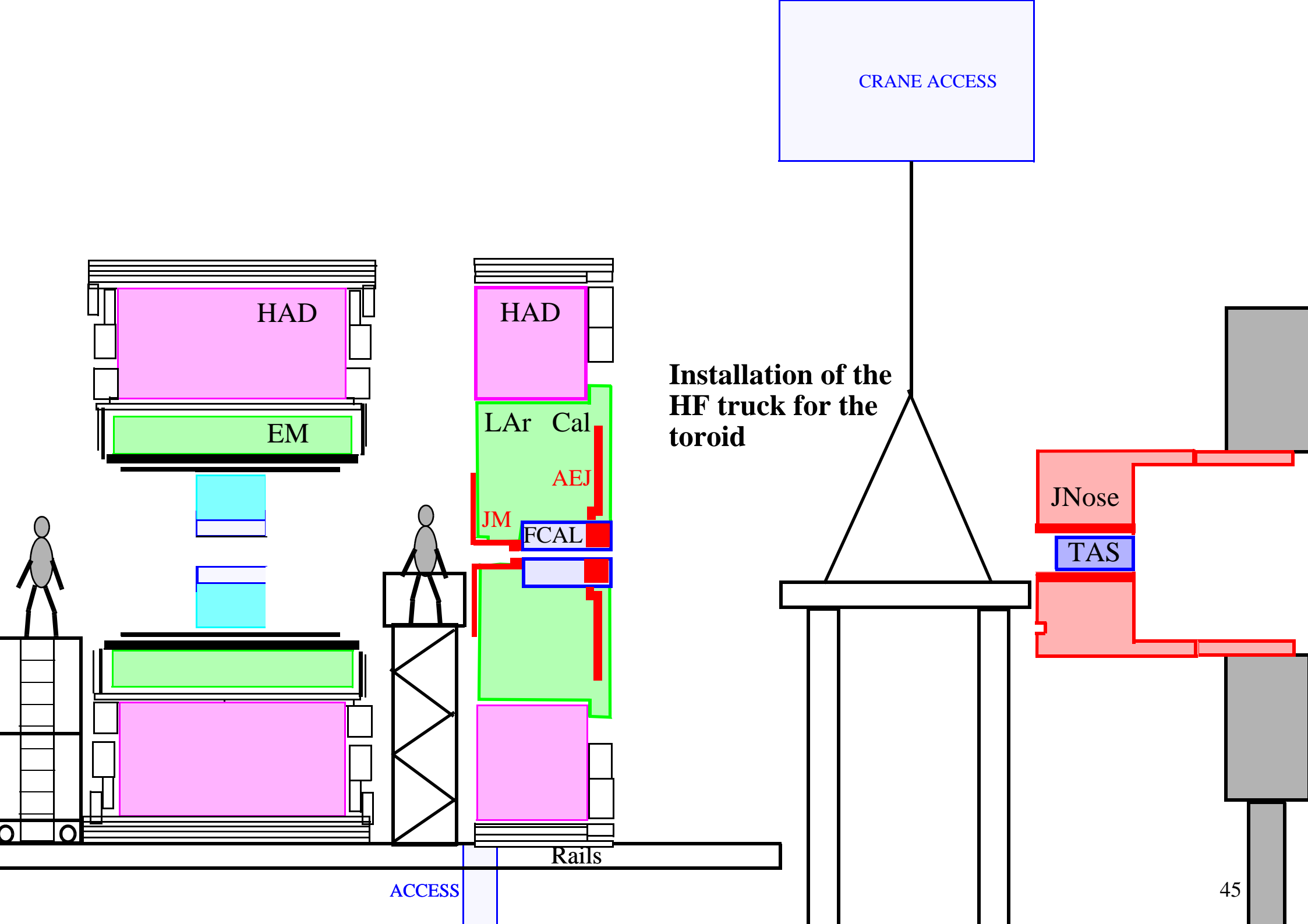

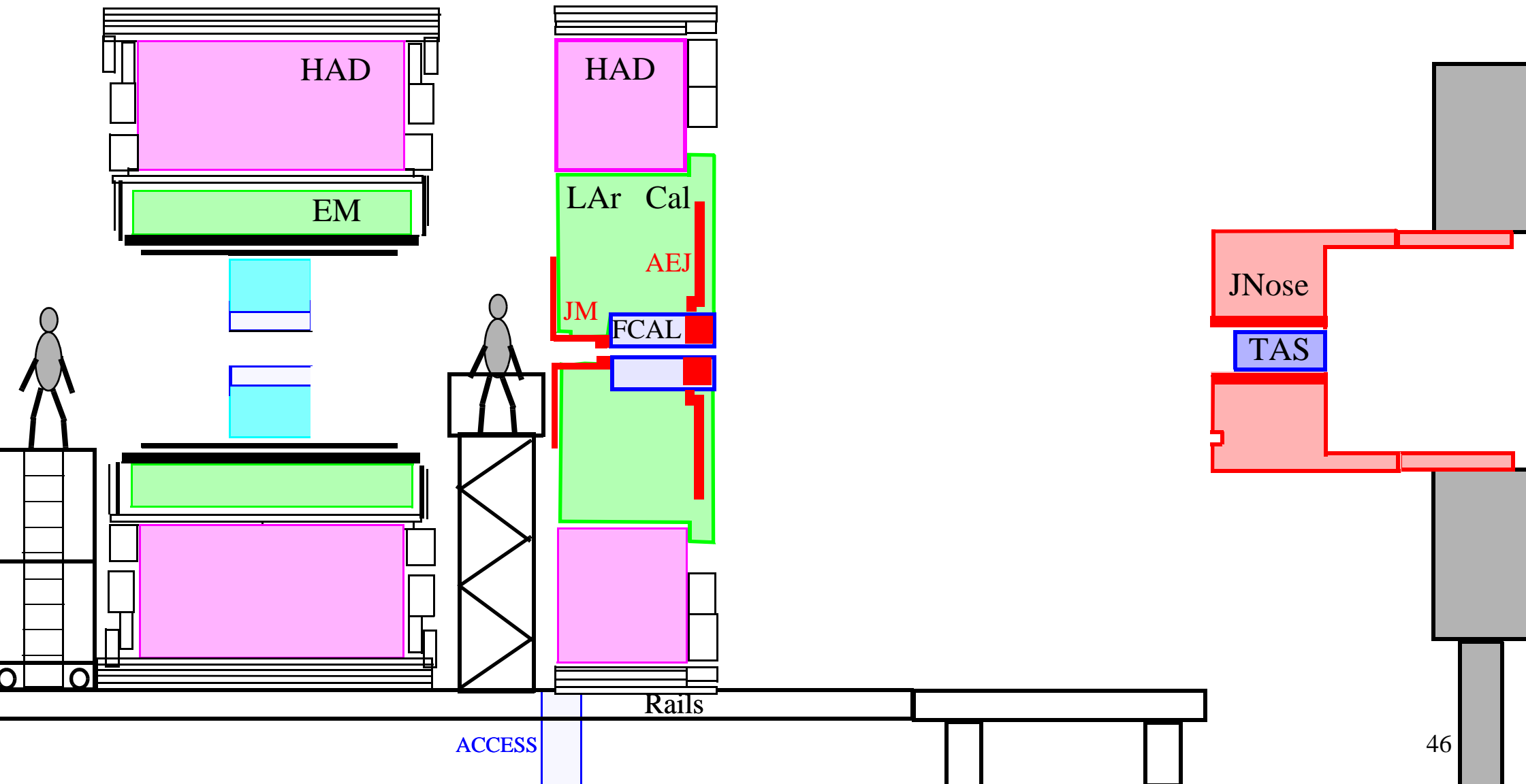

September 2006

The ID-C is installed from the C-side.
Is the scaffolding on the A-side sufficient ?

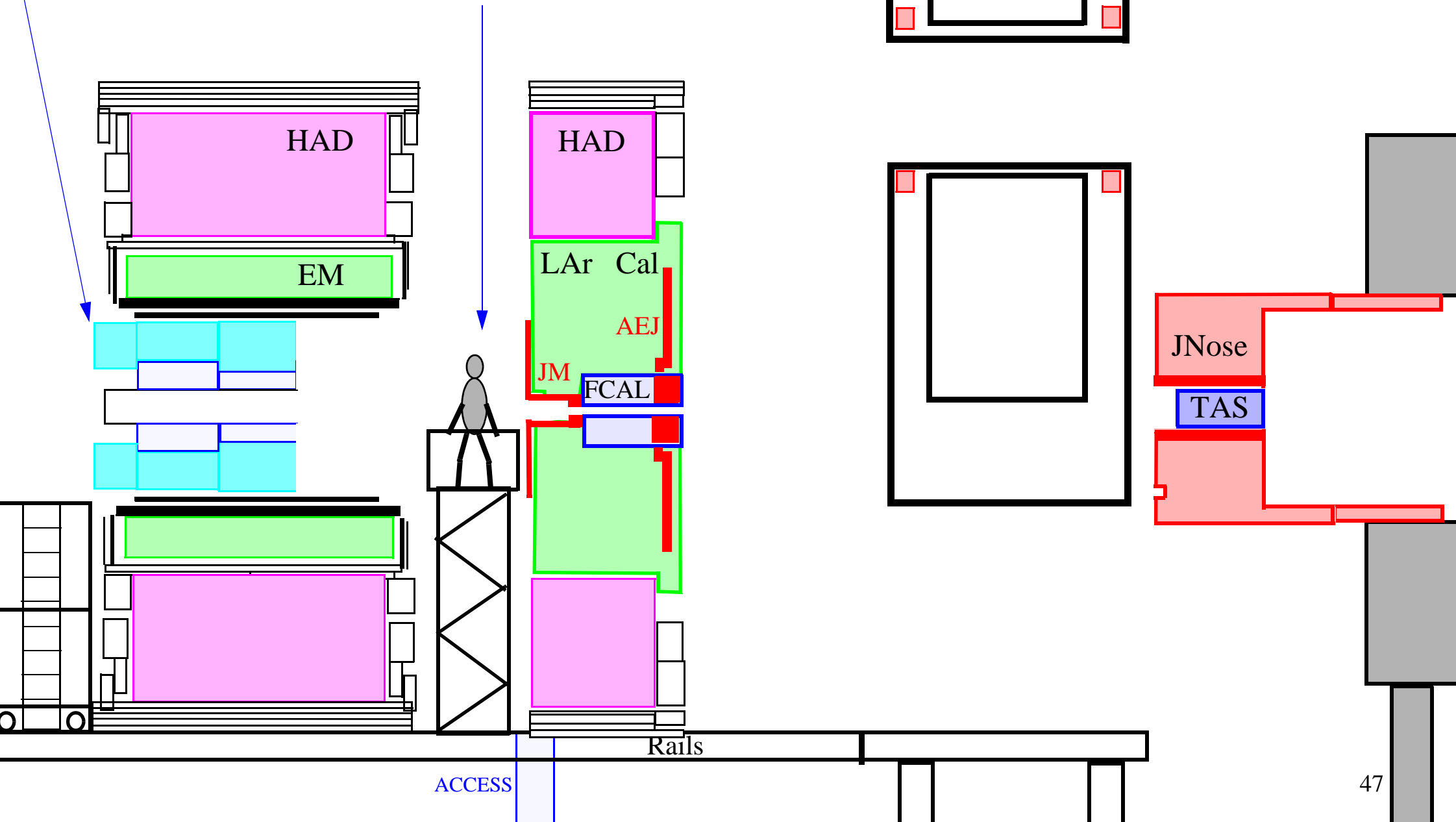

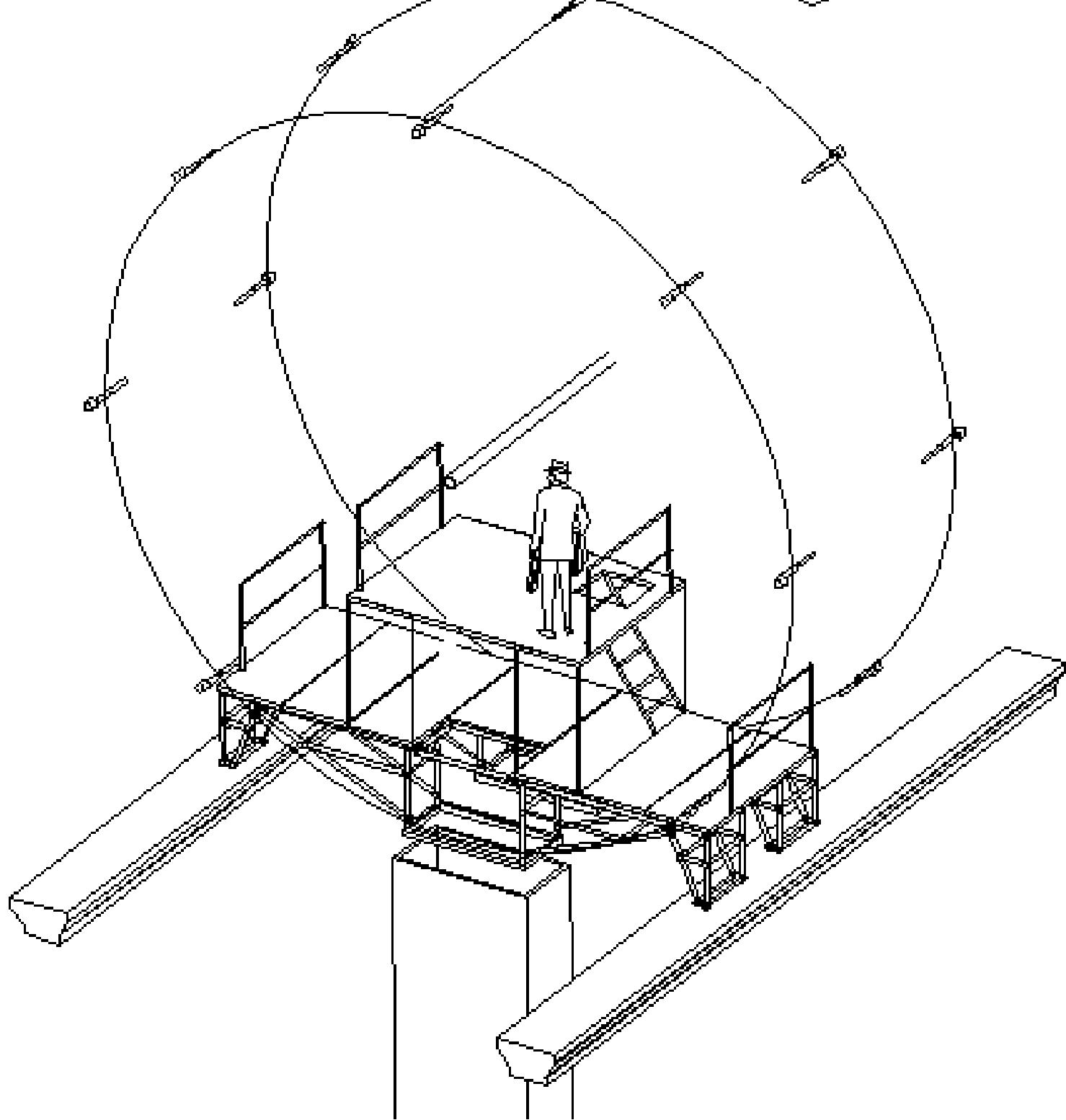

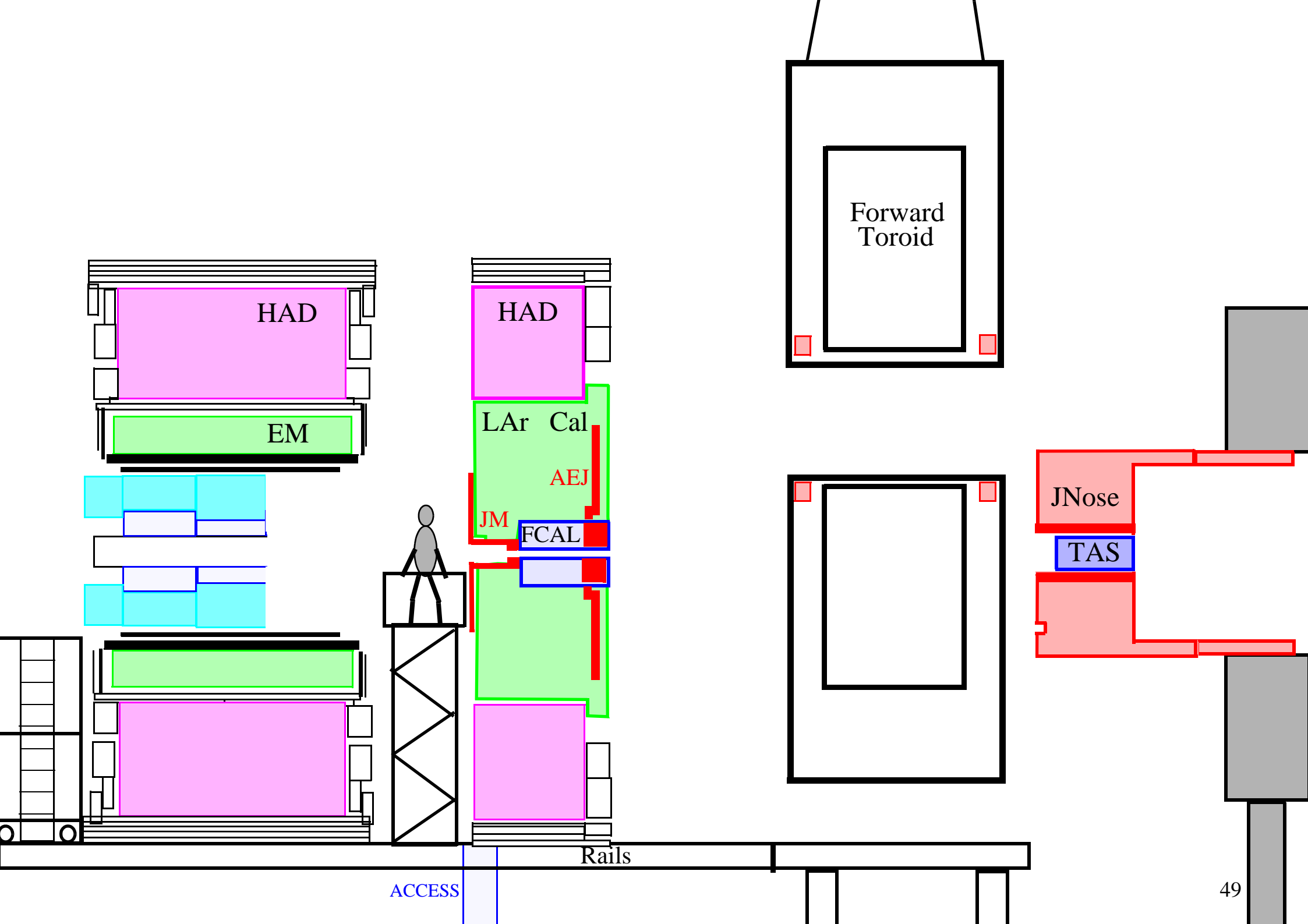

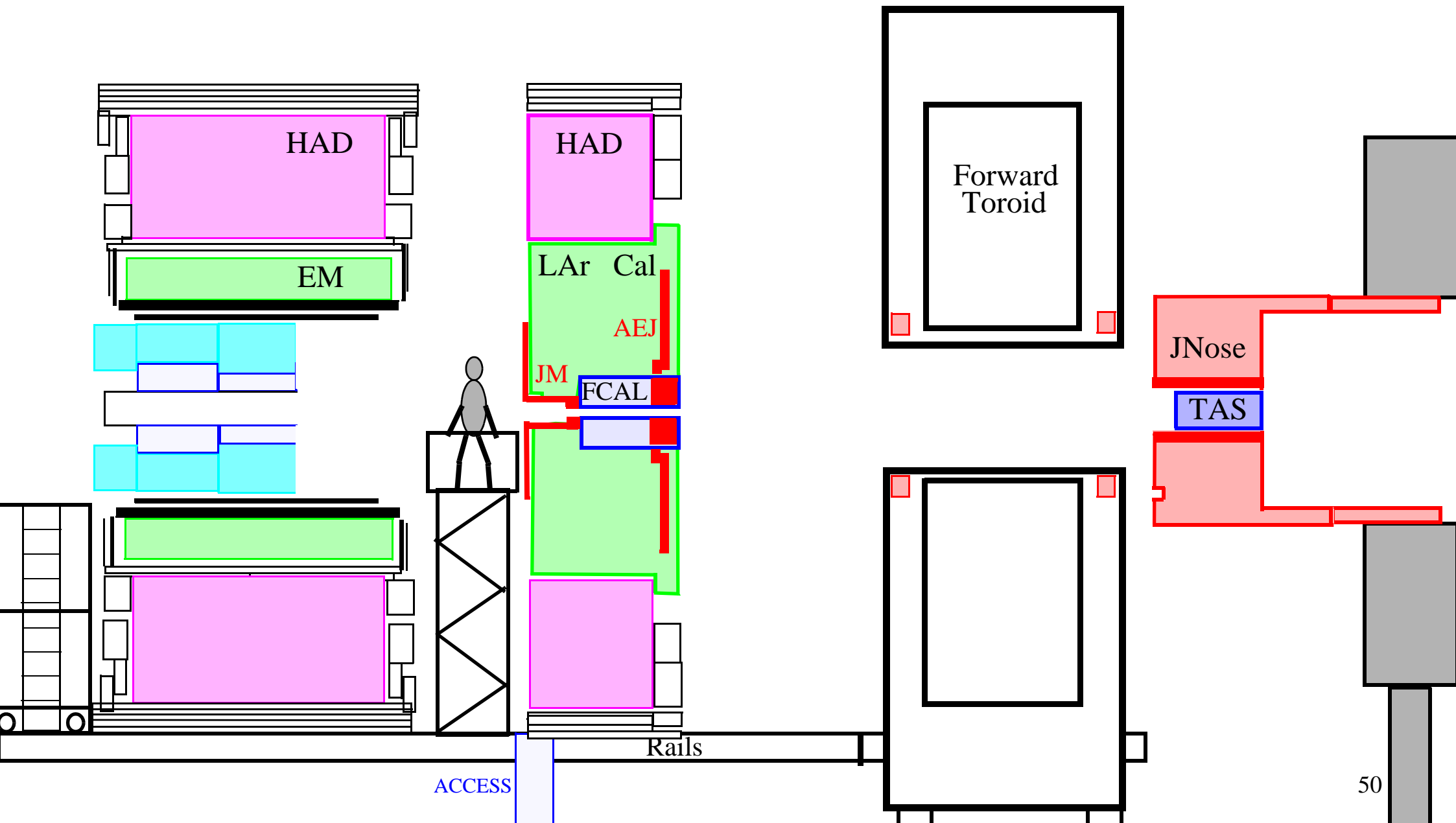

HAD

EM

HAD

LAr Cal

AEJ

JM

FCAL

HAD

Forward
Toroid

JNose

TAS

Rails

ACCESS

50

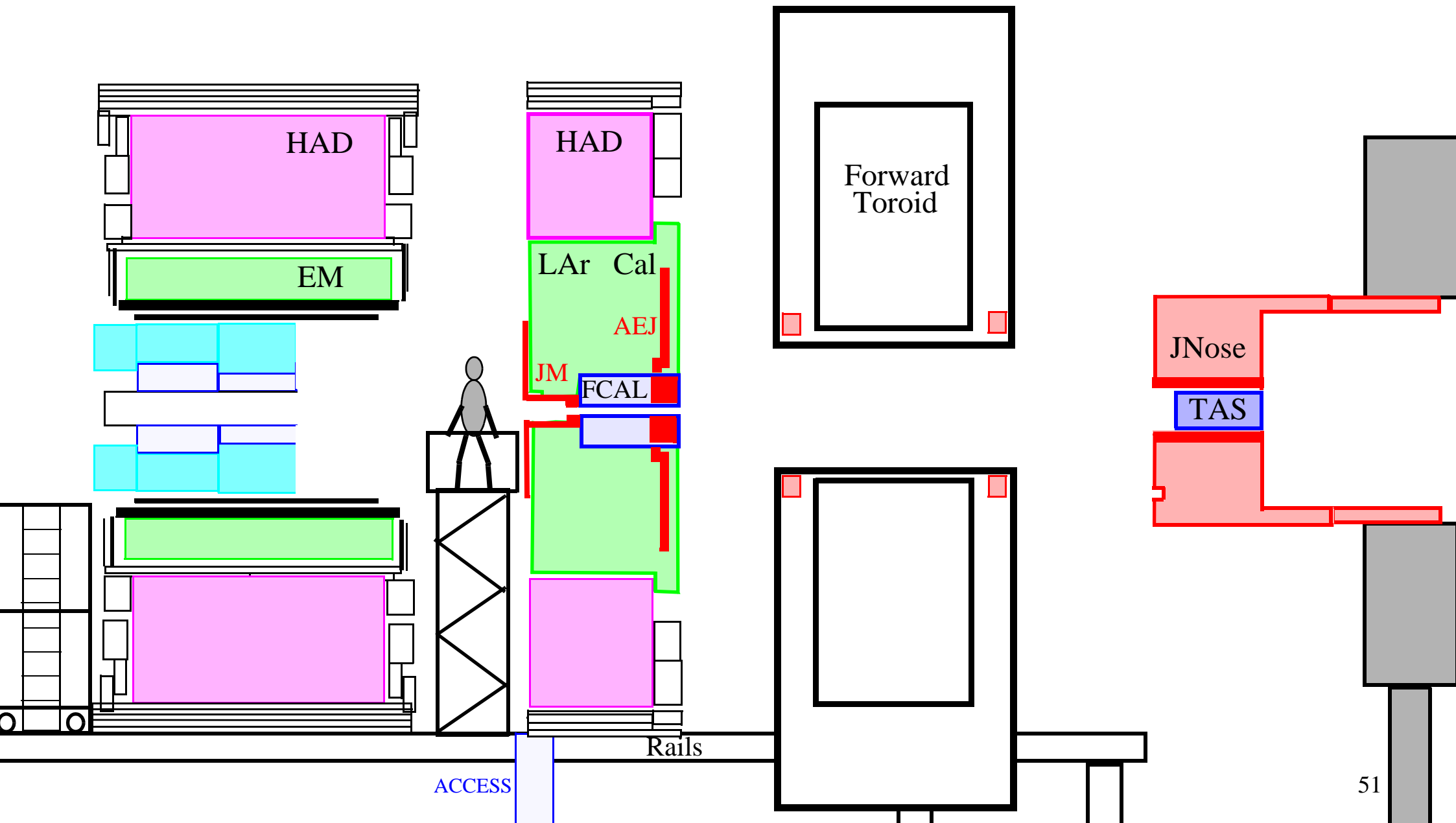

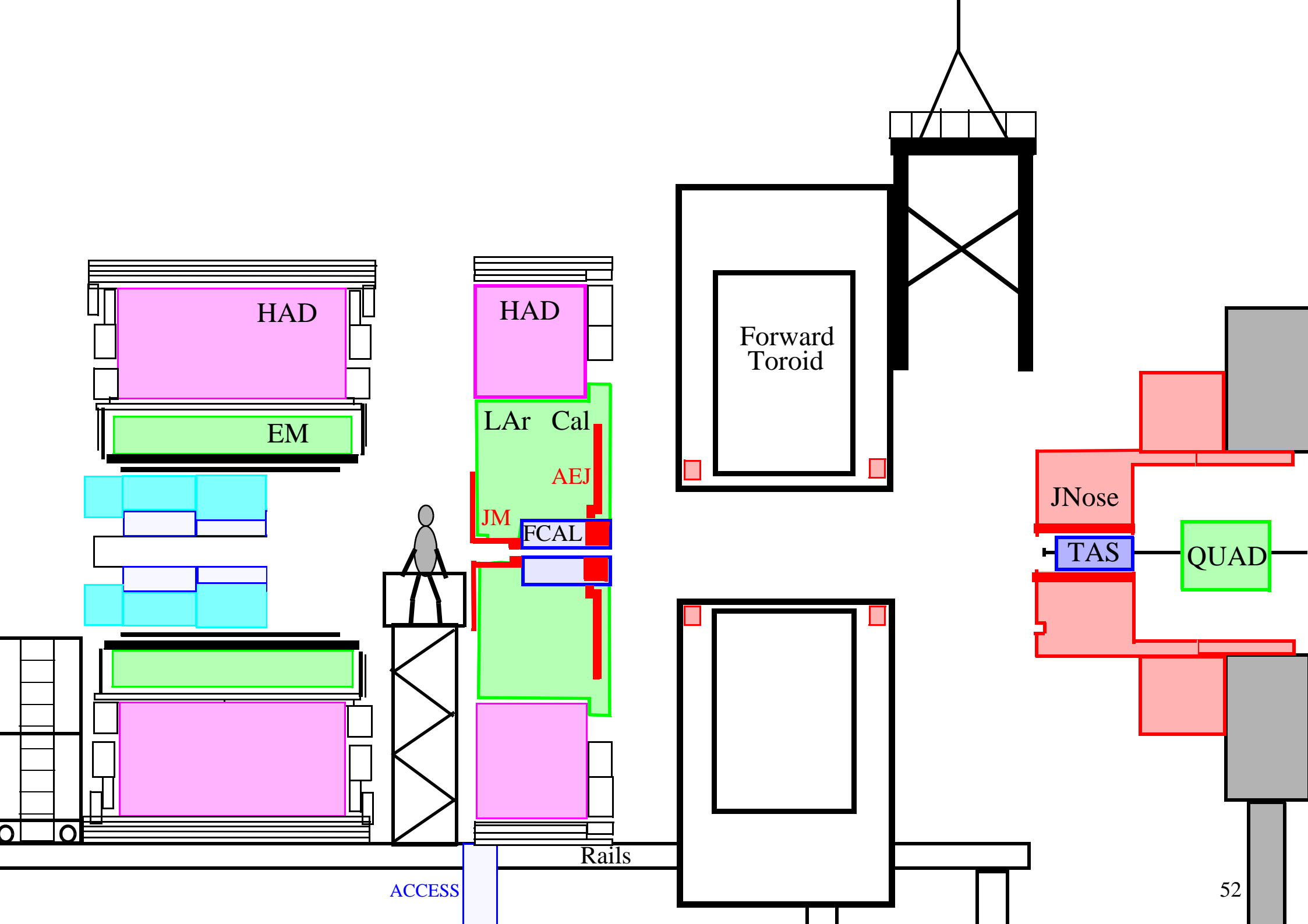

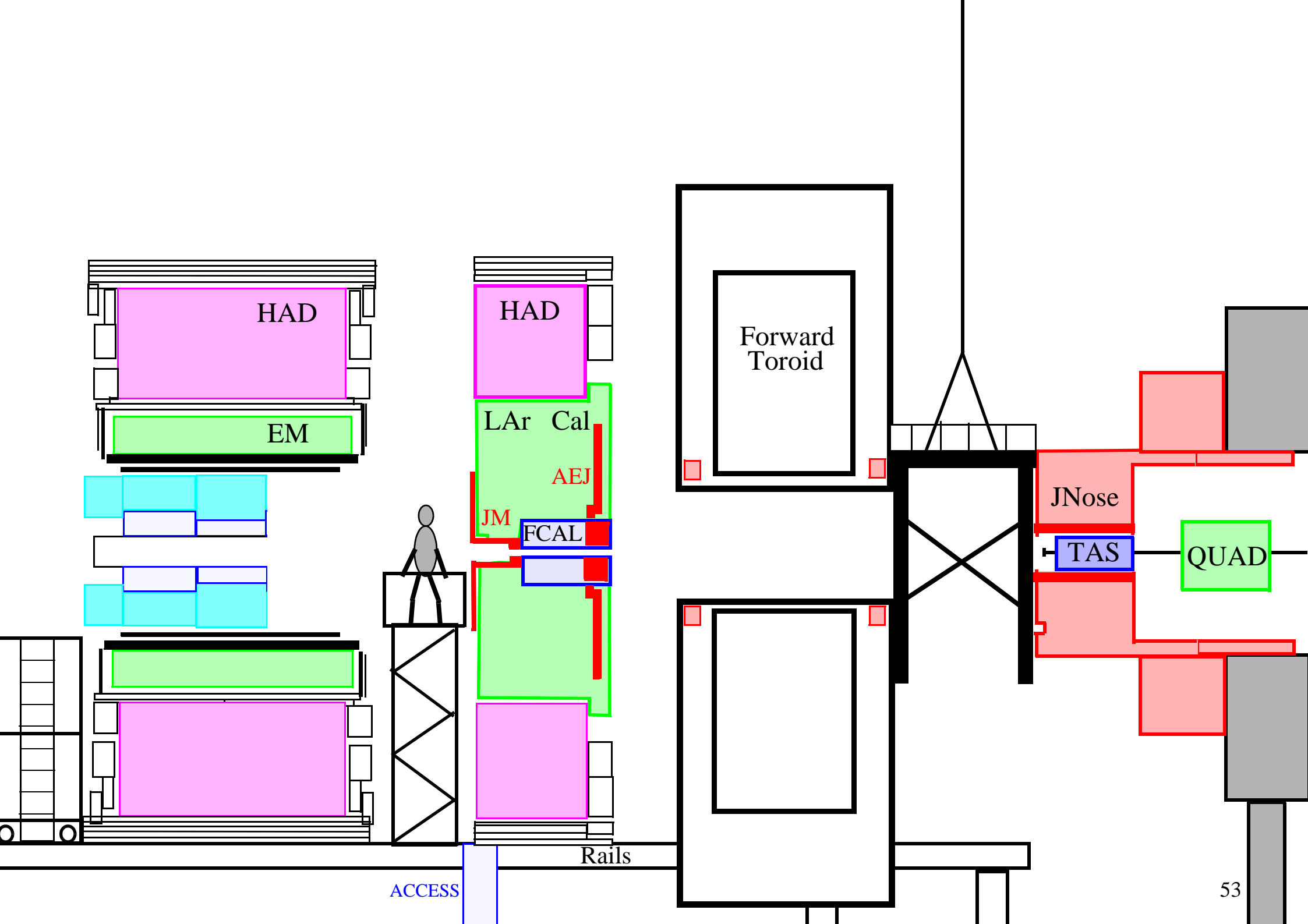

HAD

EM

HAD

LAr Cal

AEJ

JM

FCAL

Forward
Toroid

JNose

TAS

QUAD

Rails

ACCESS

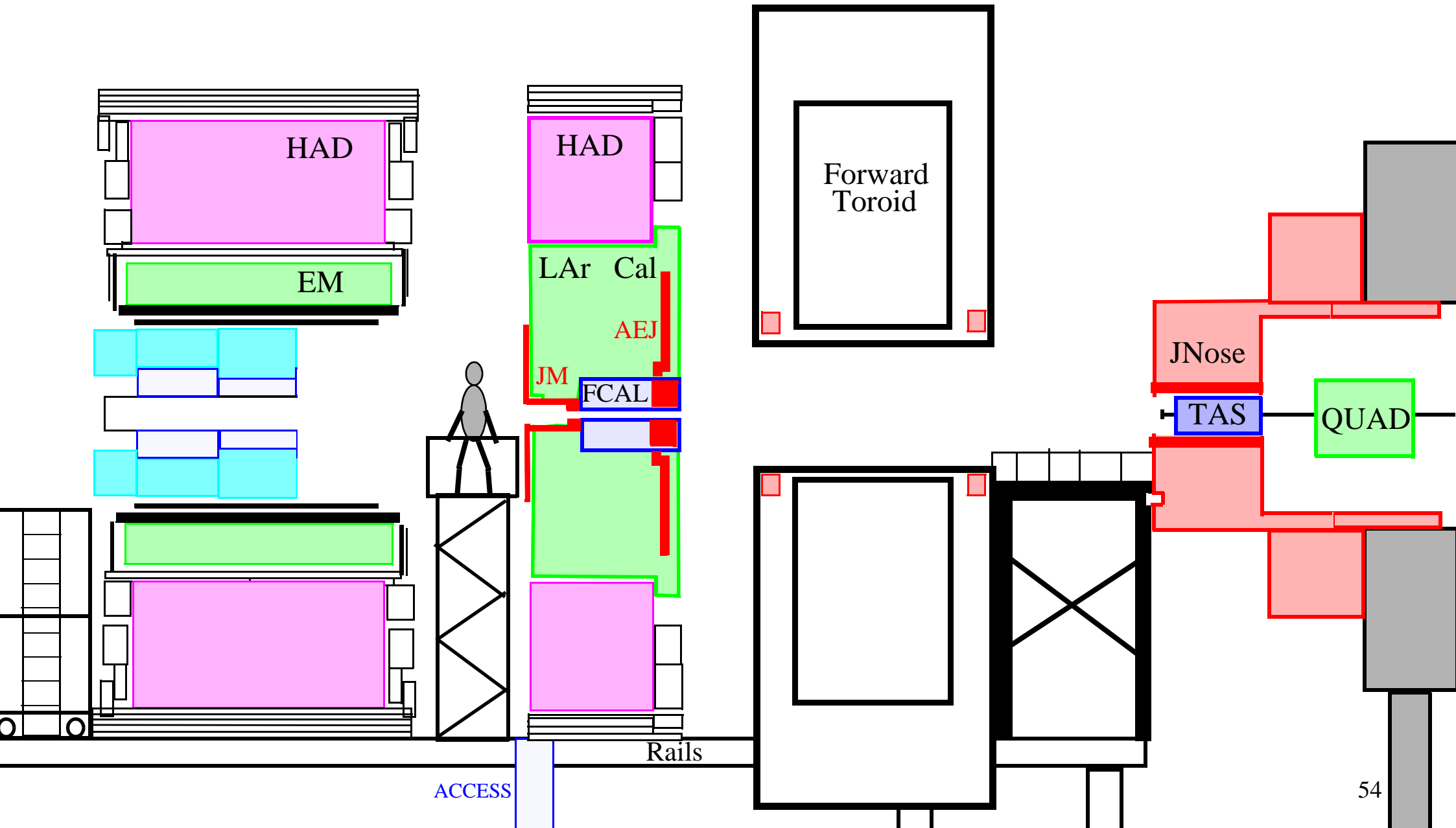

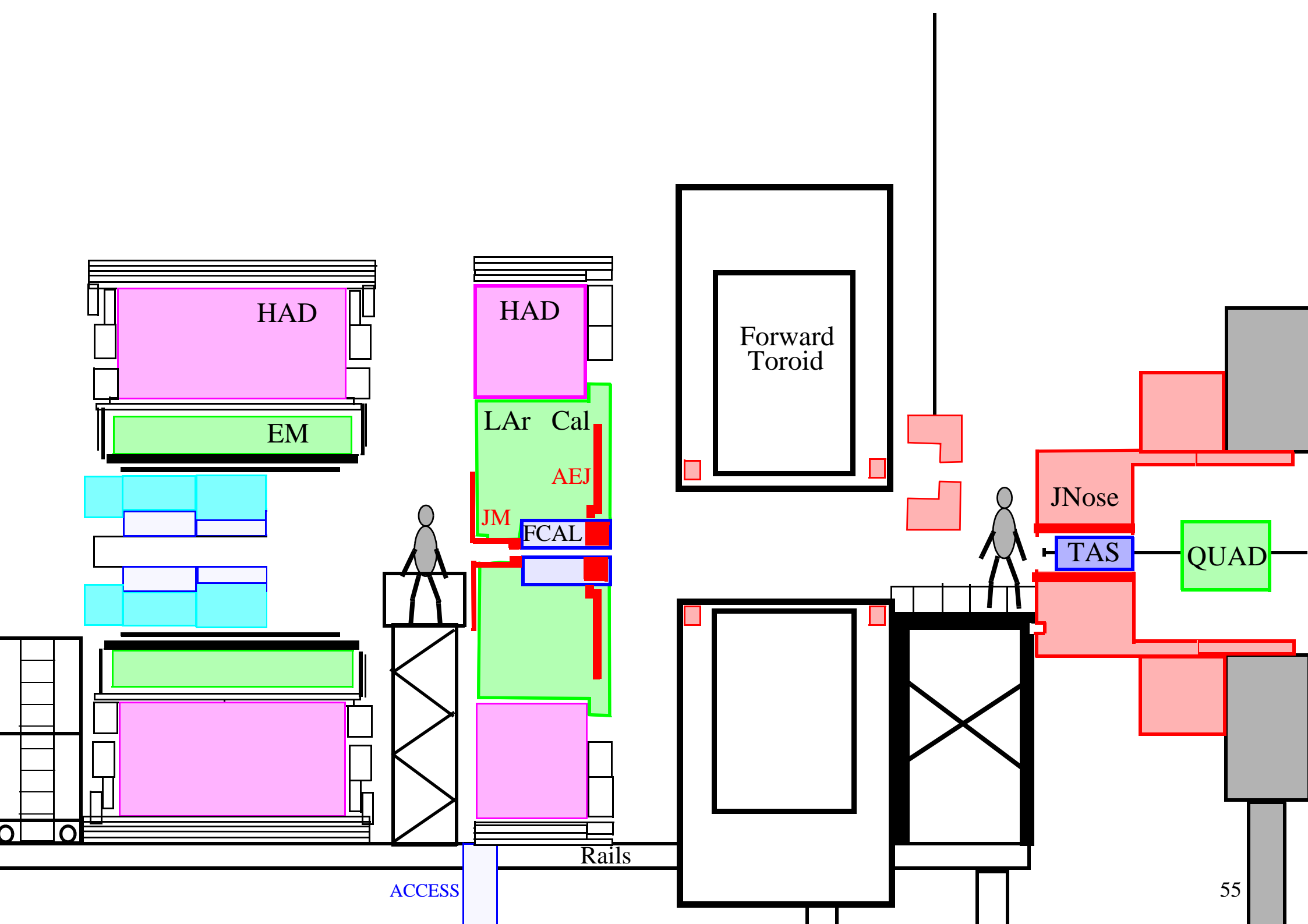

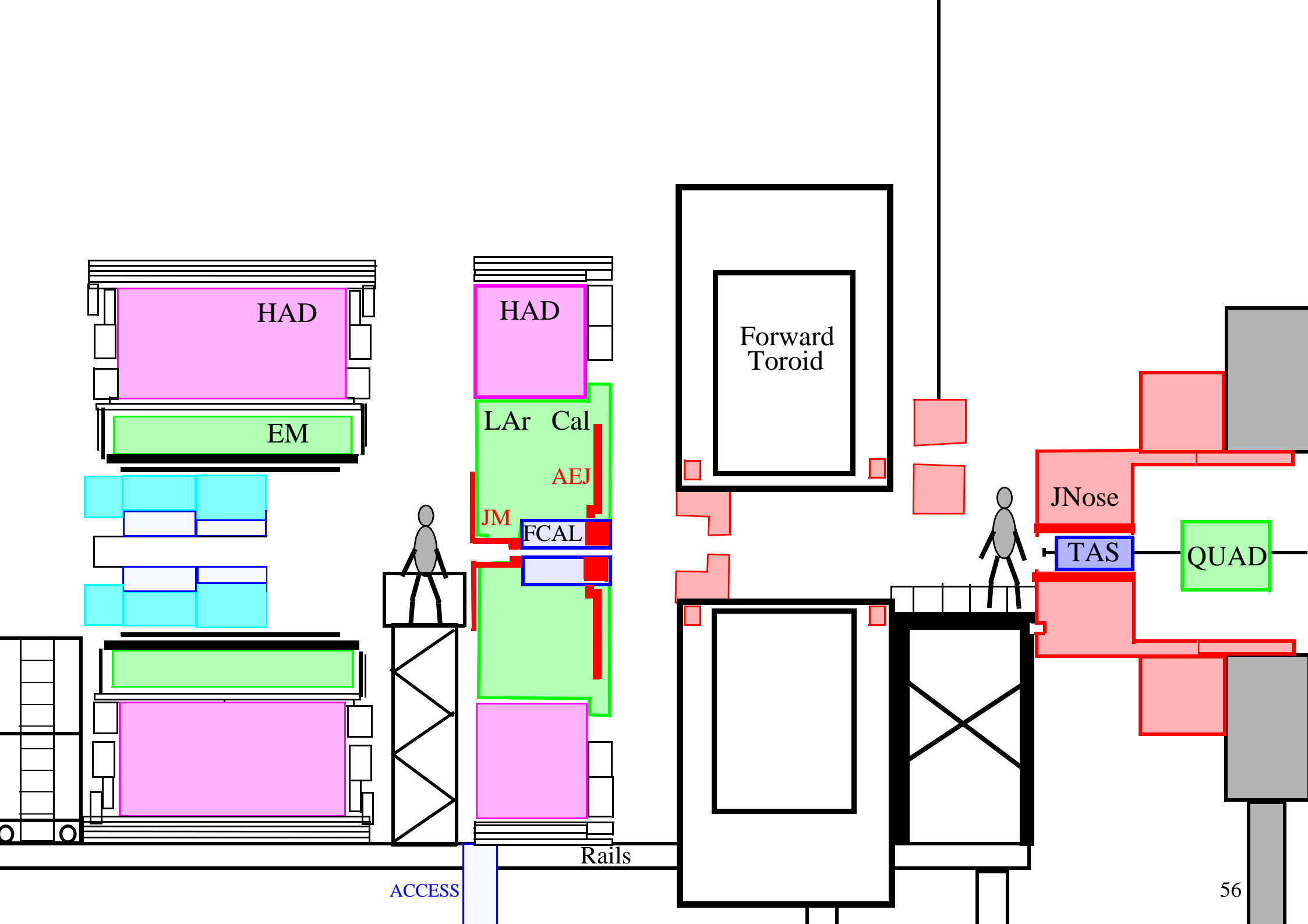

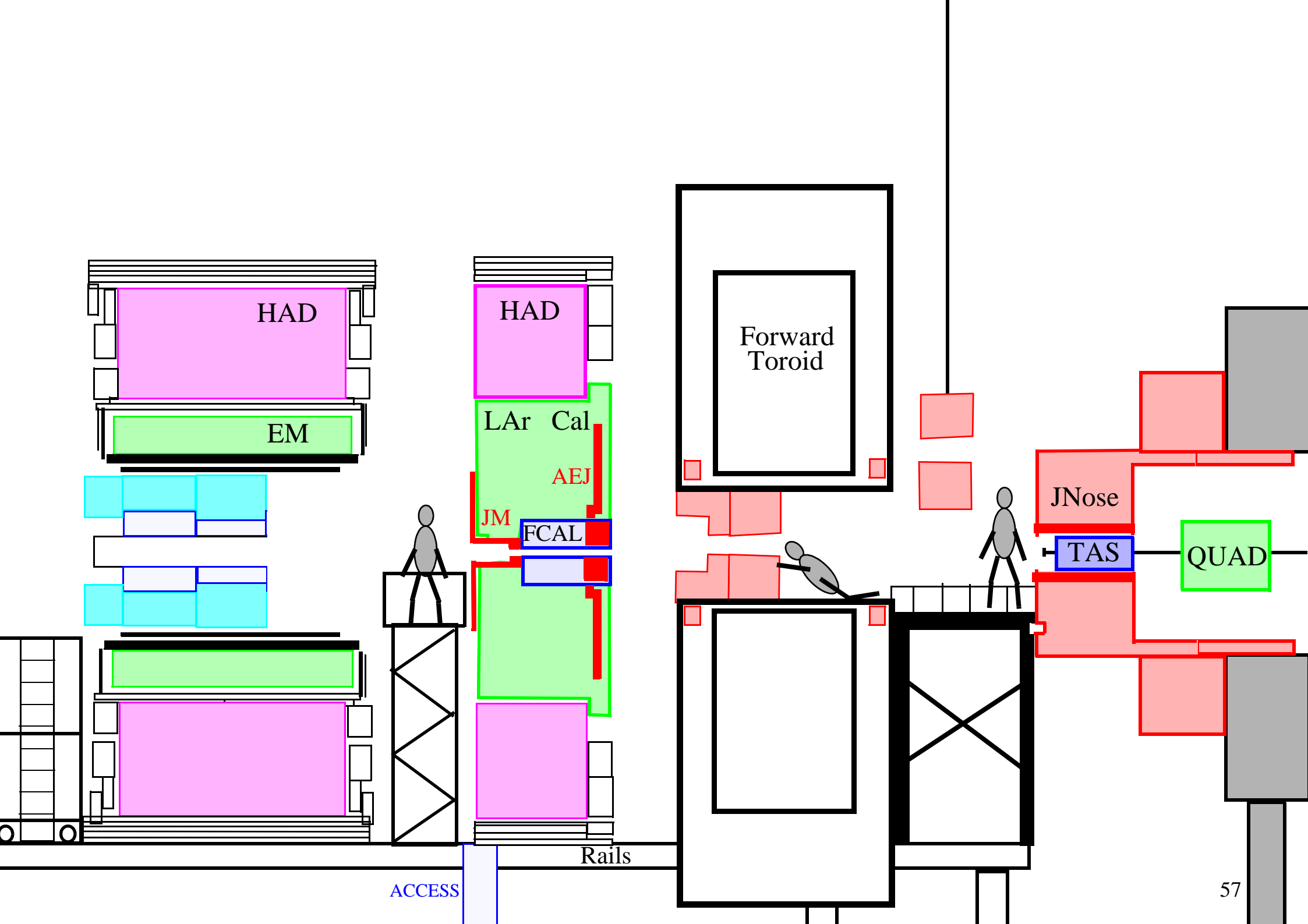

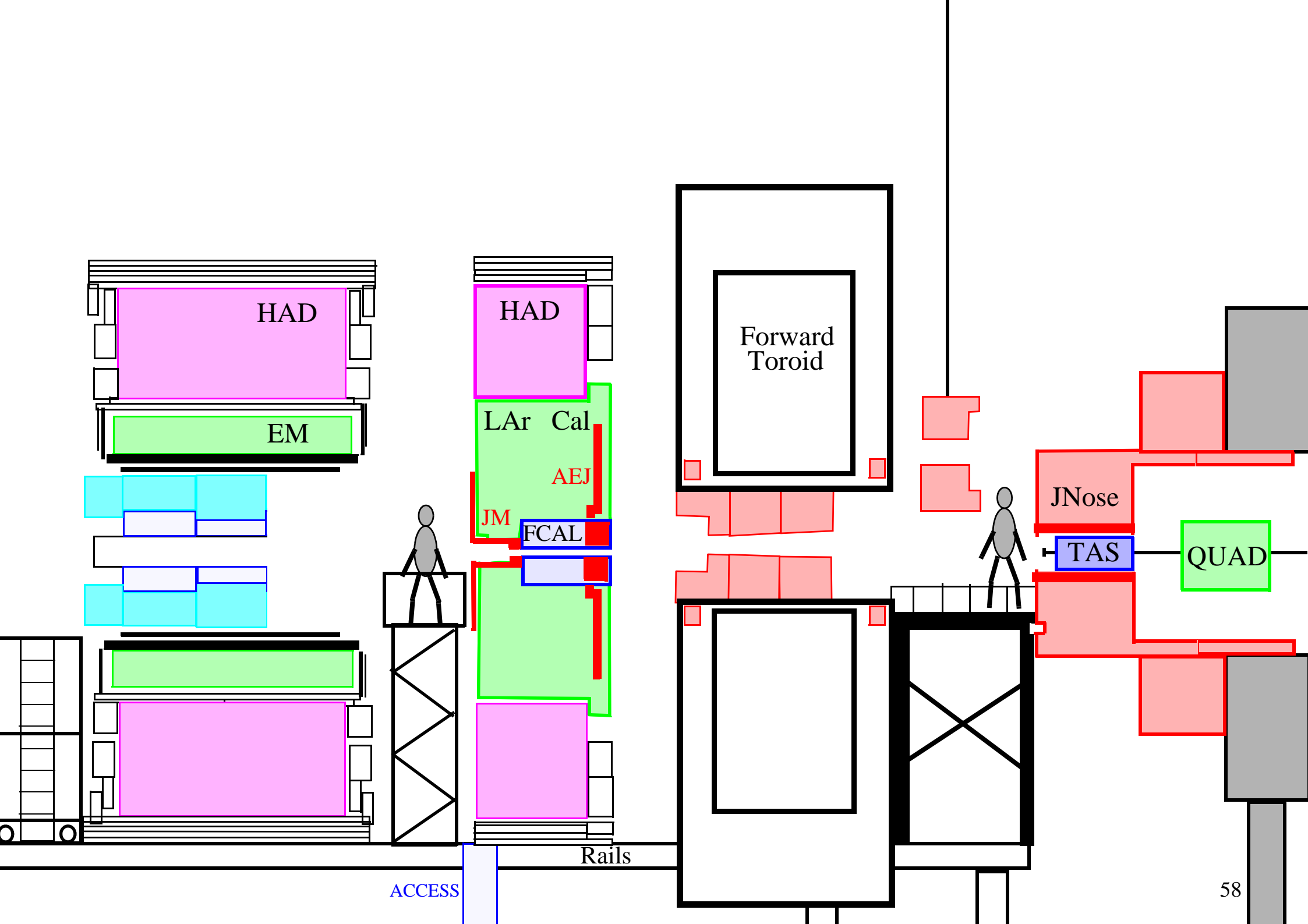

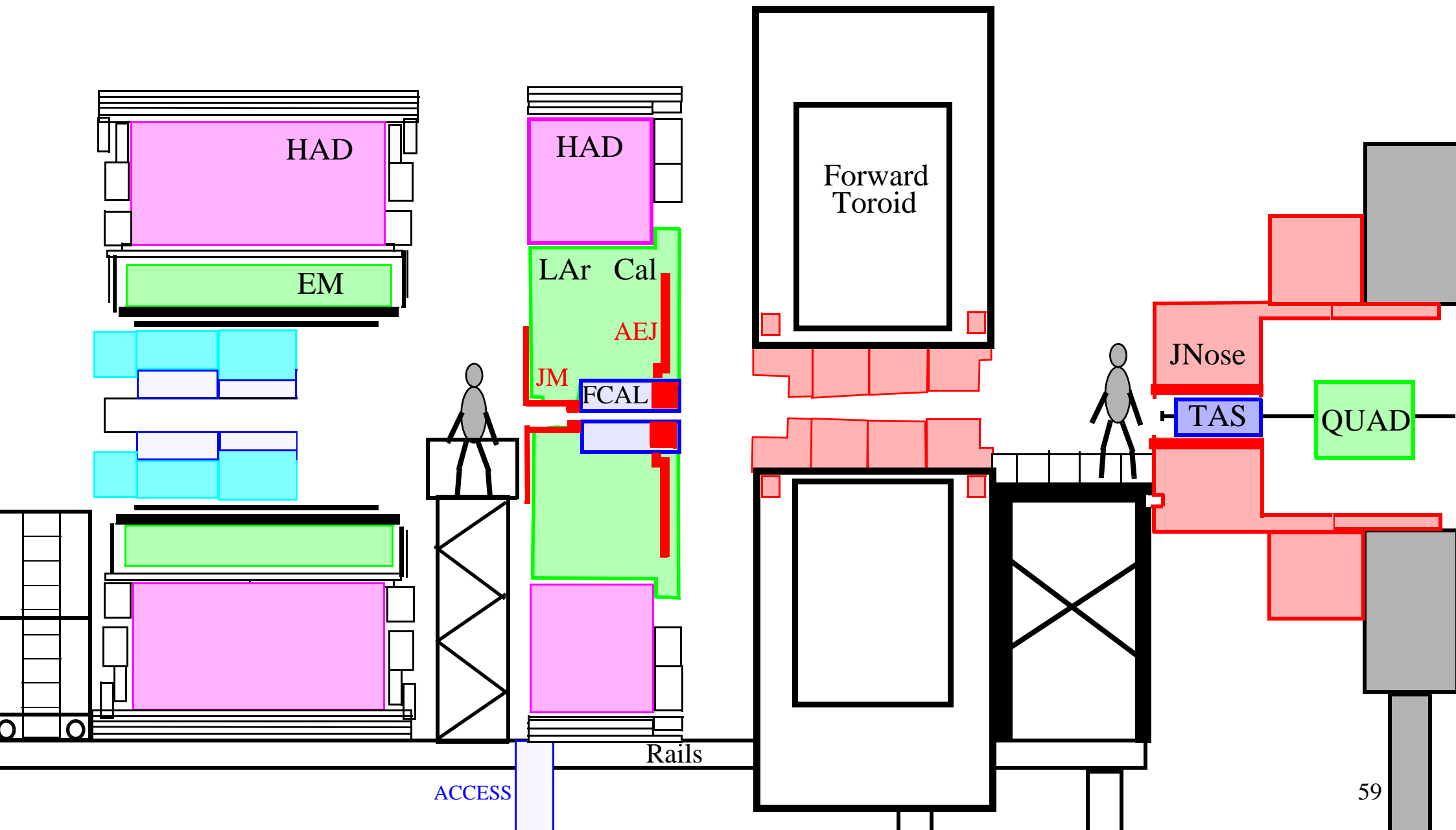

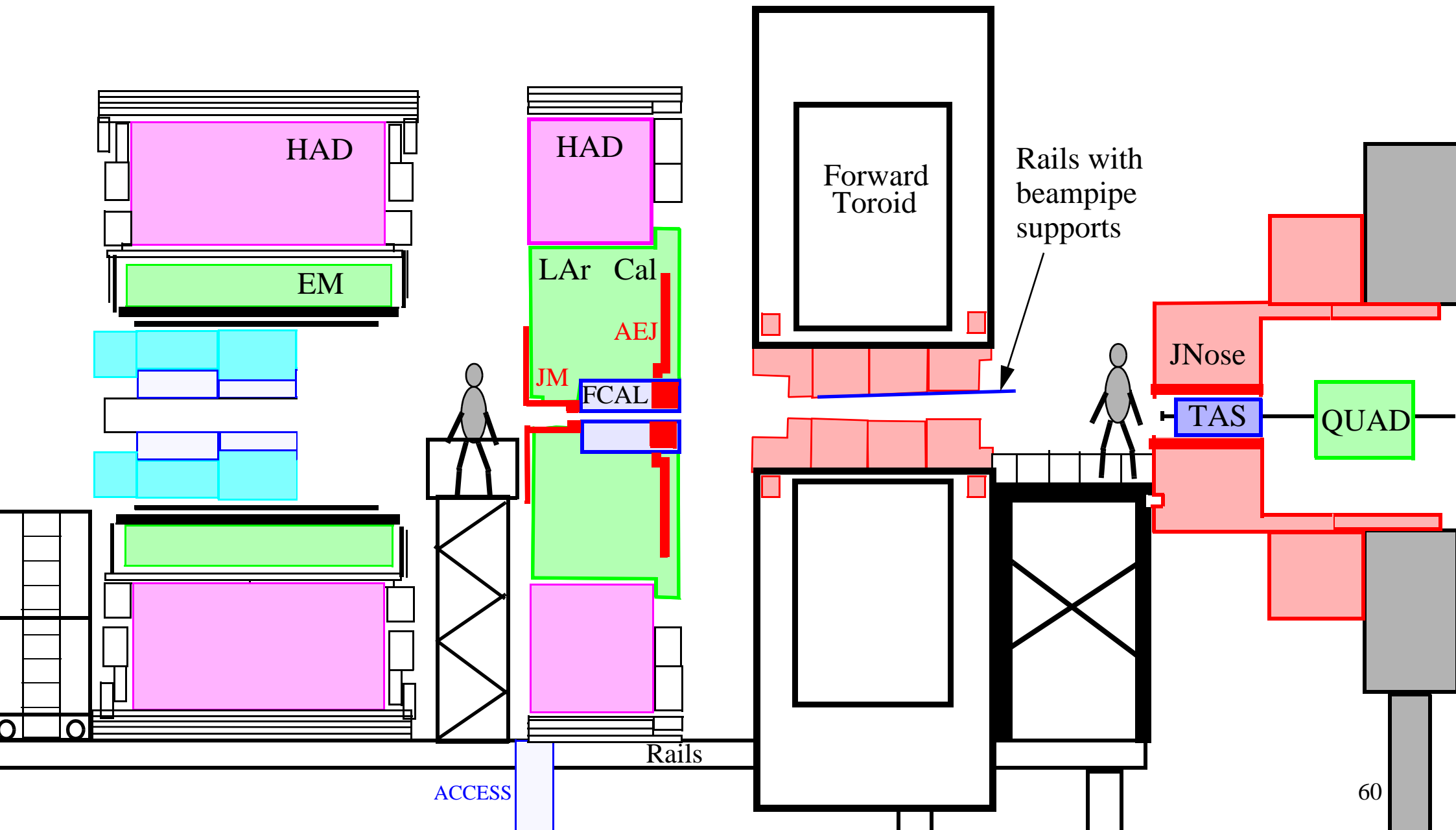

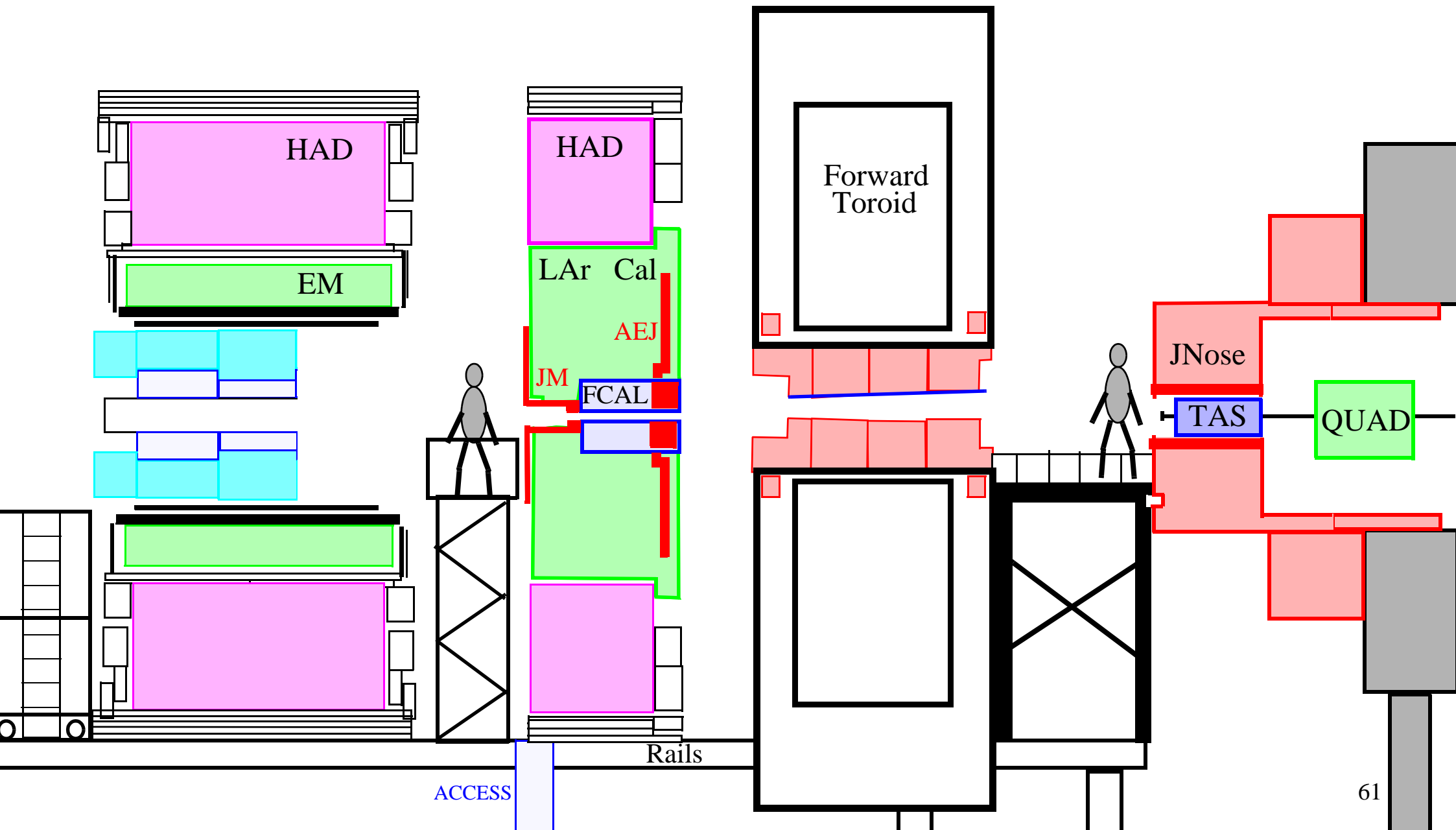

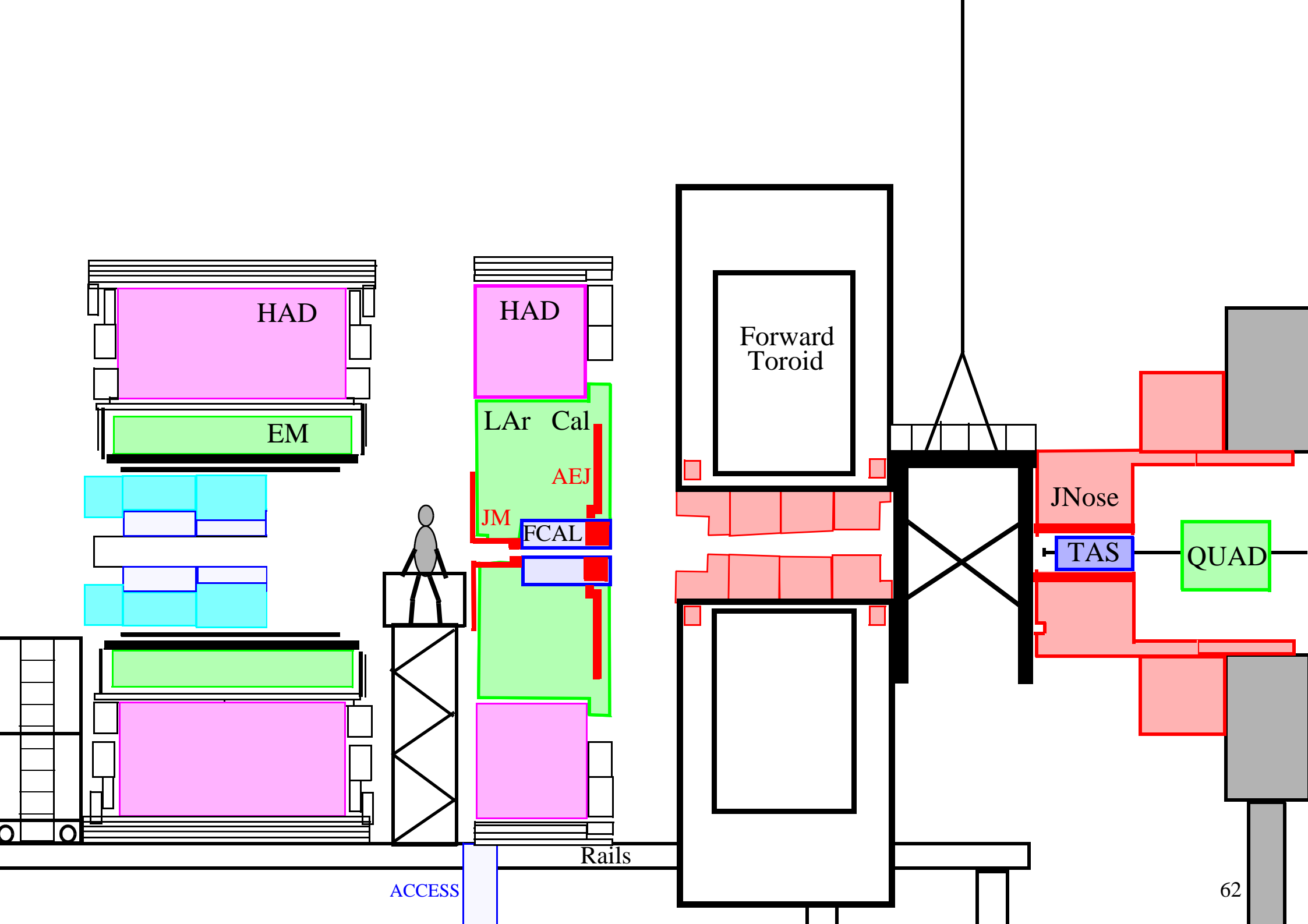

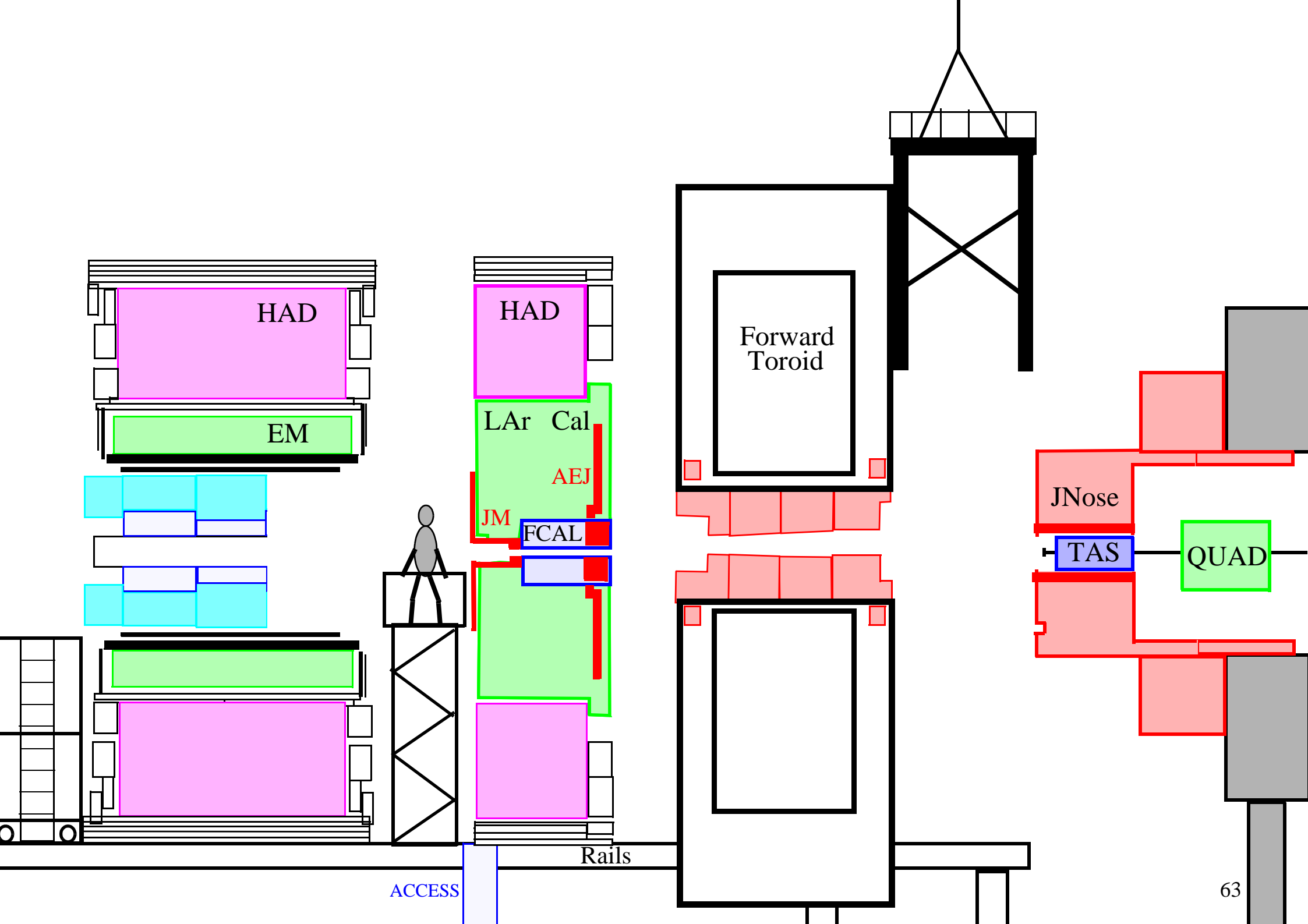

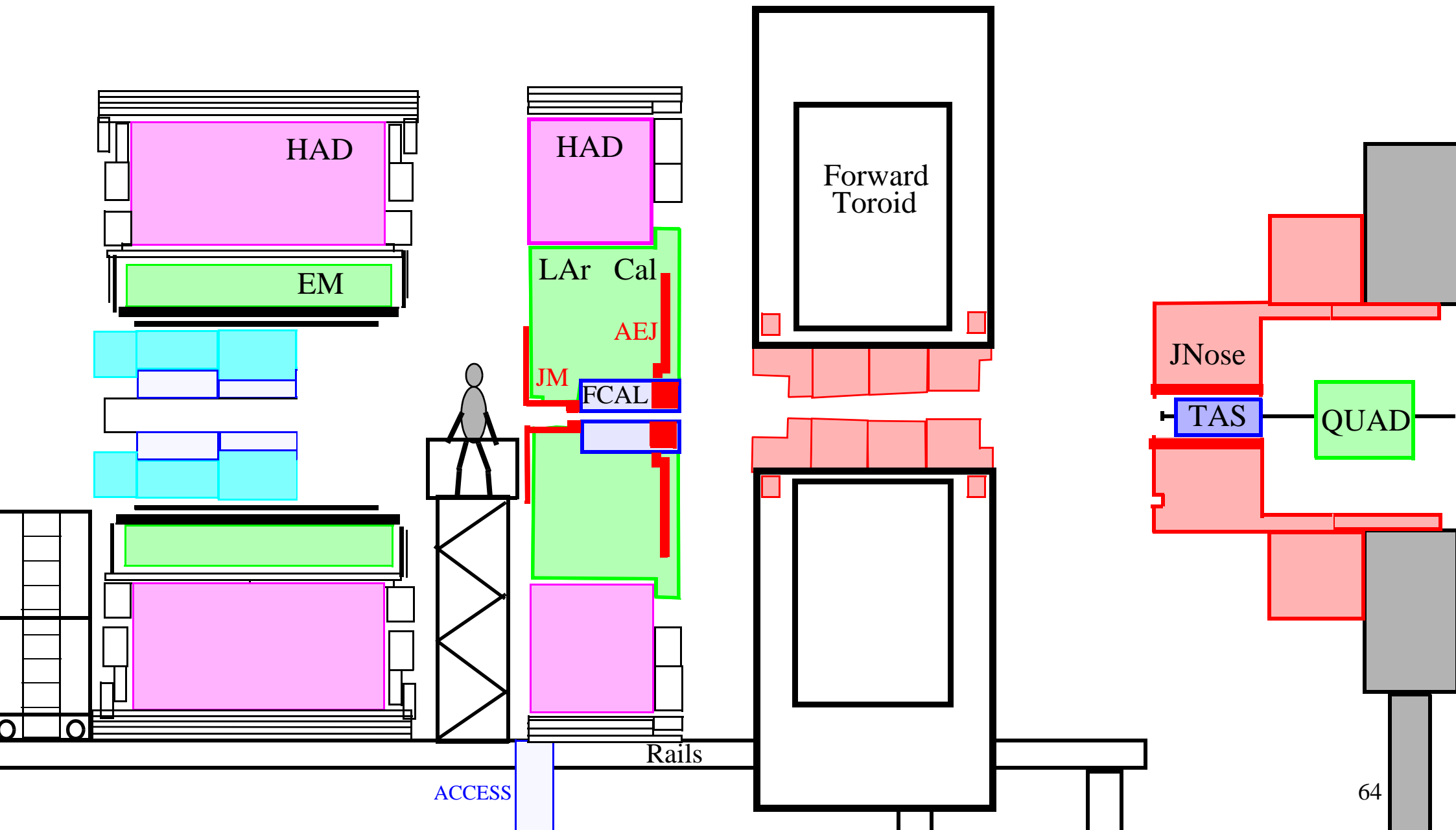

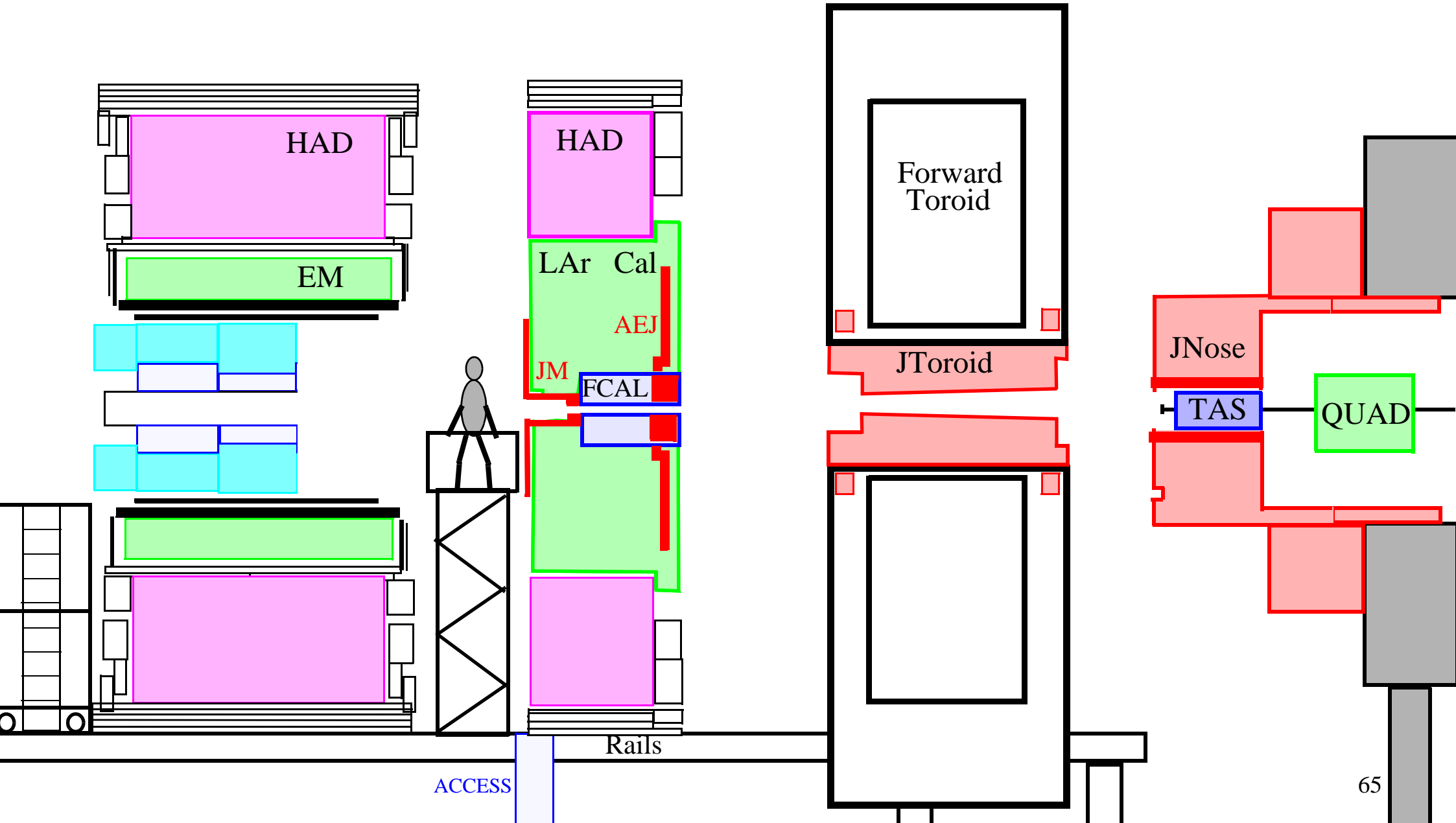

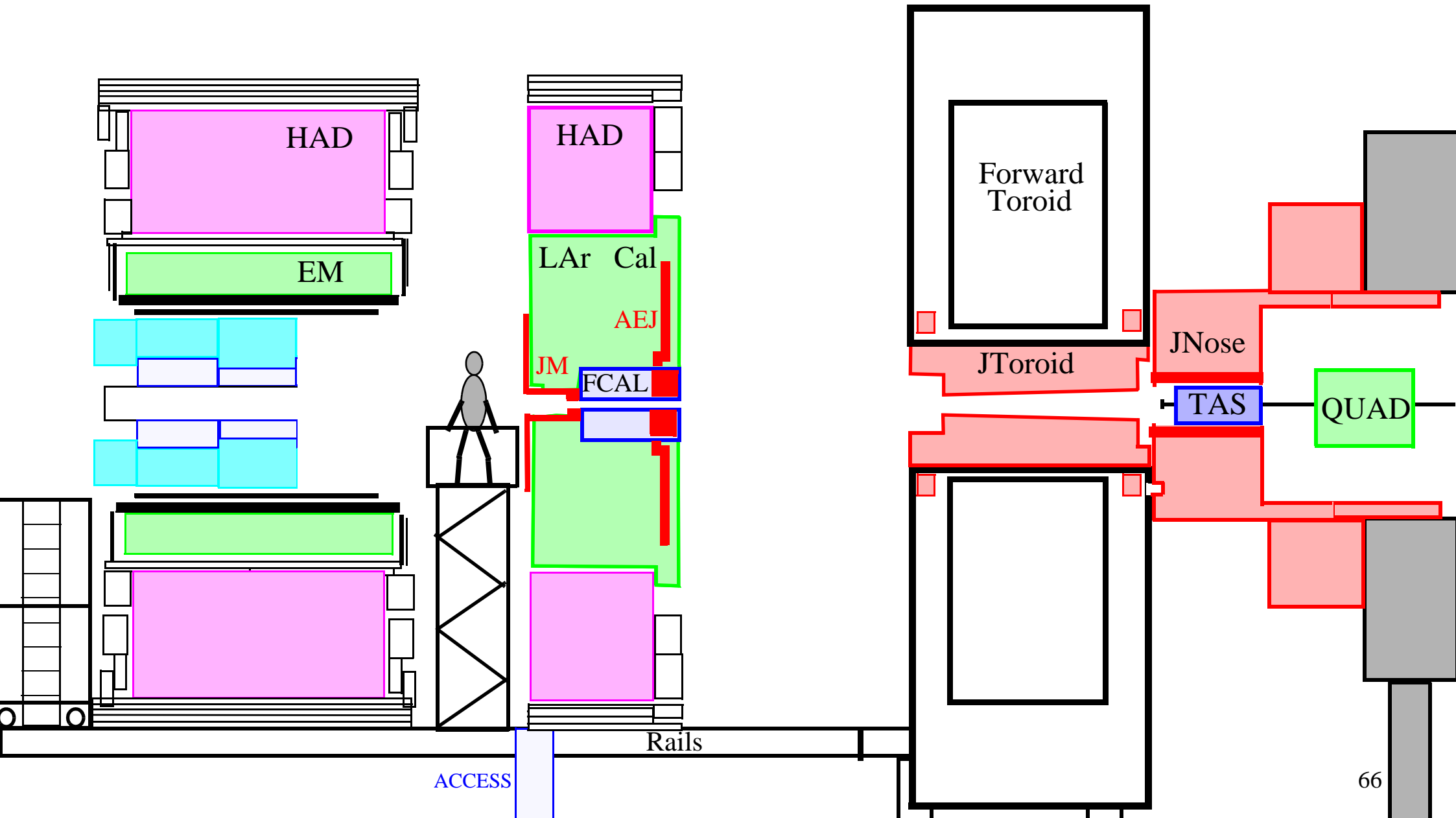

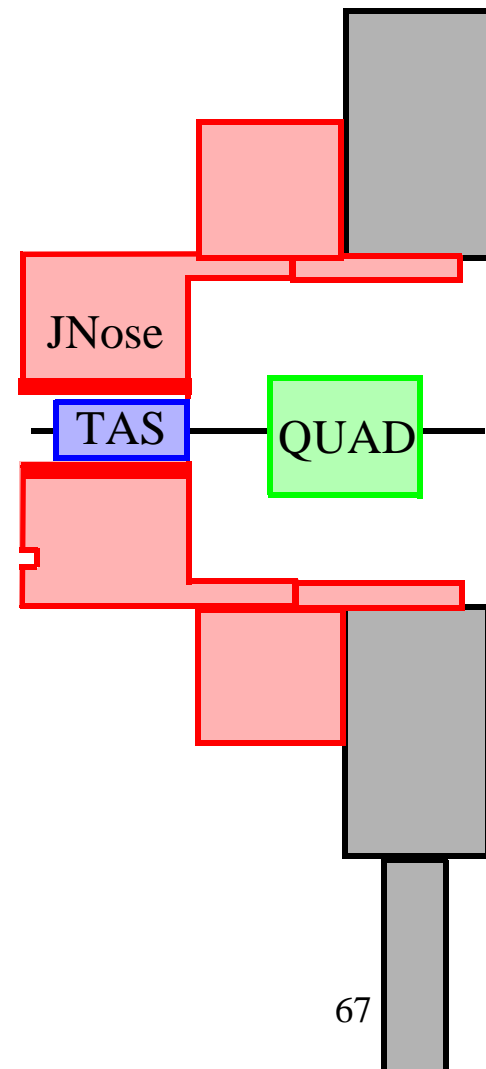
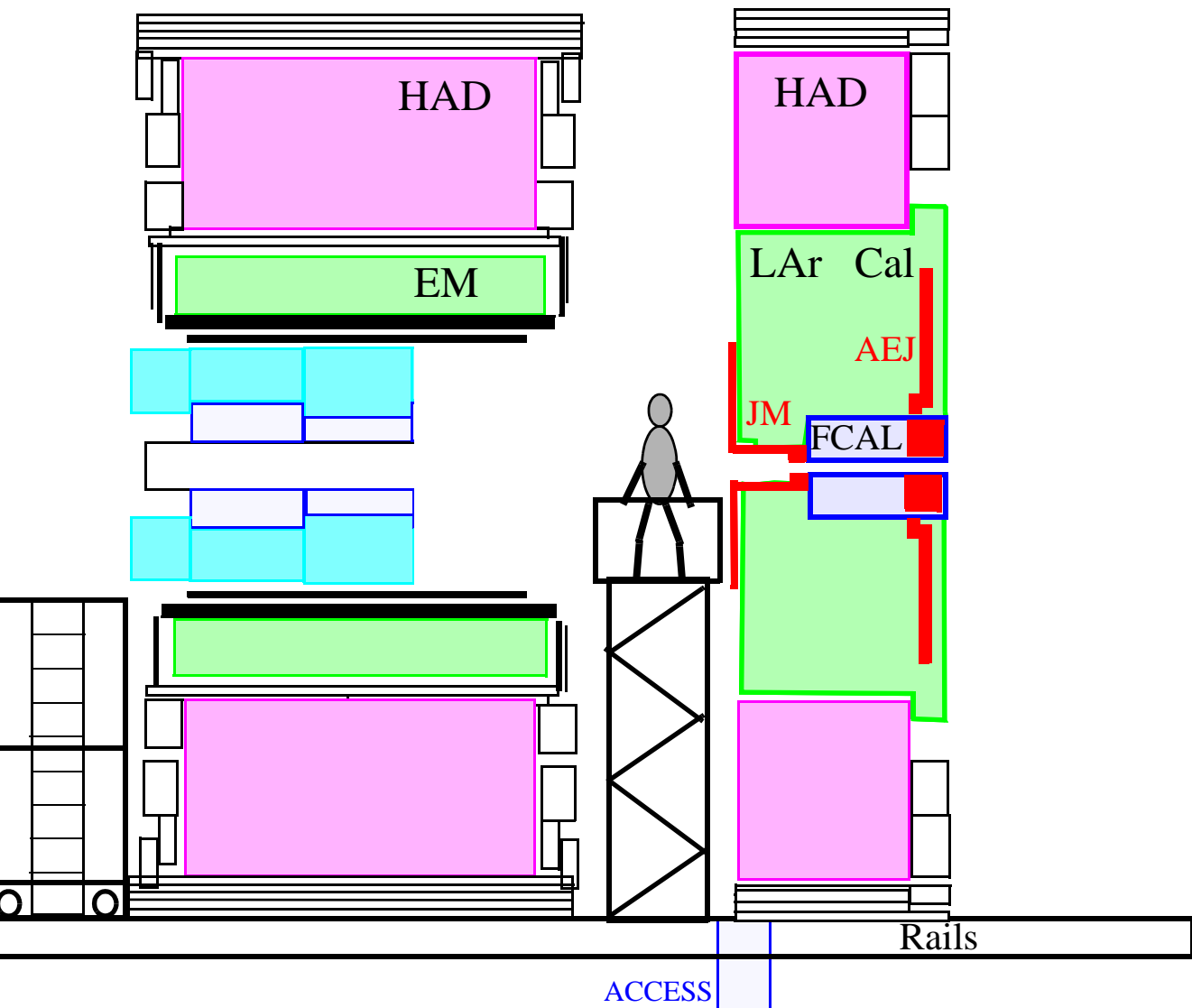

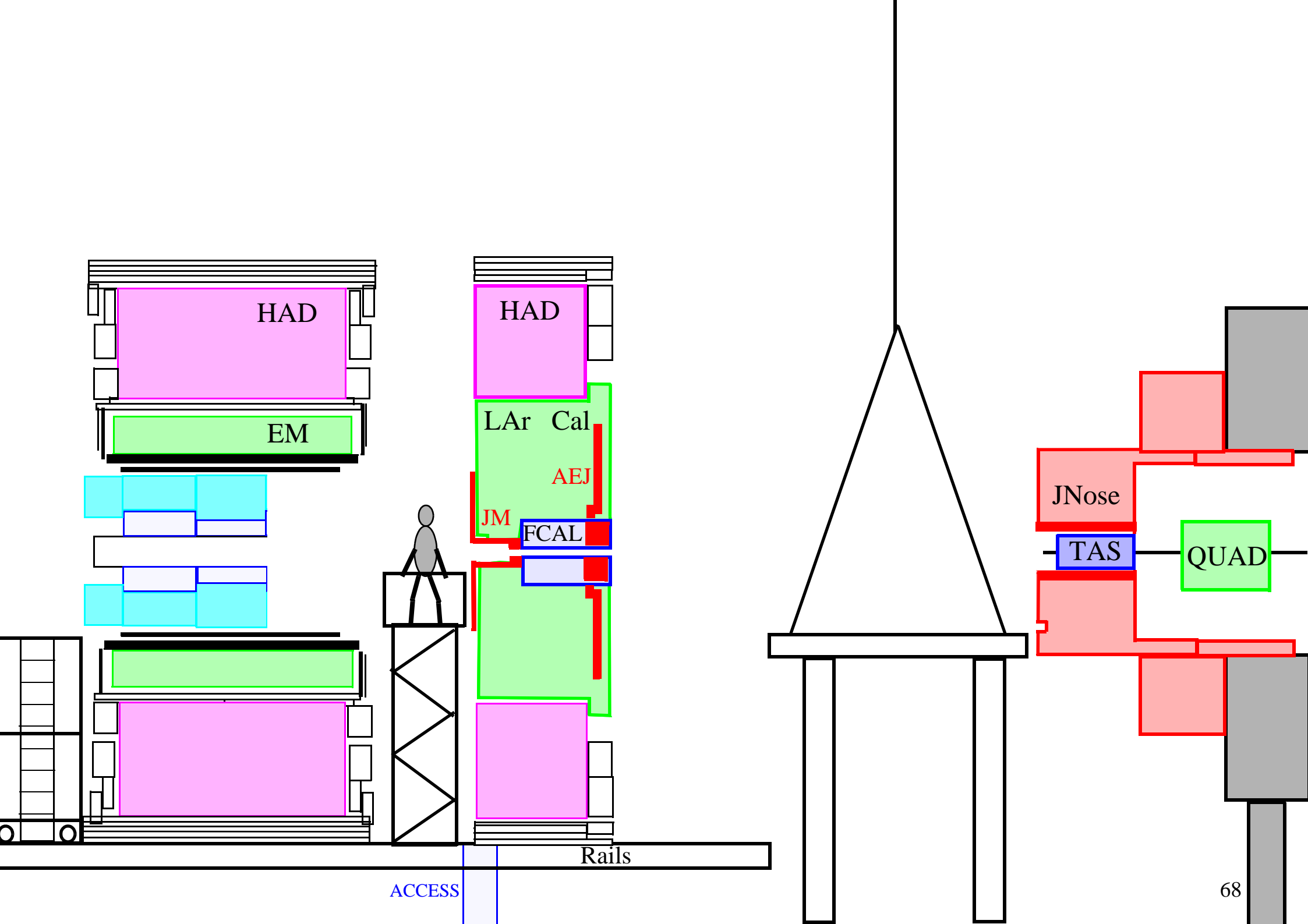

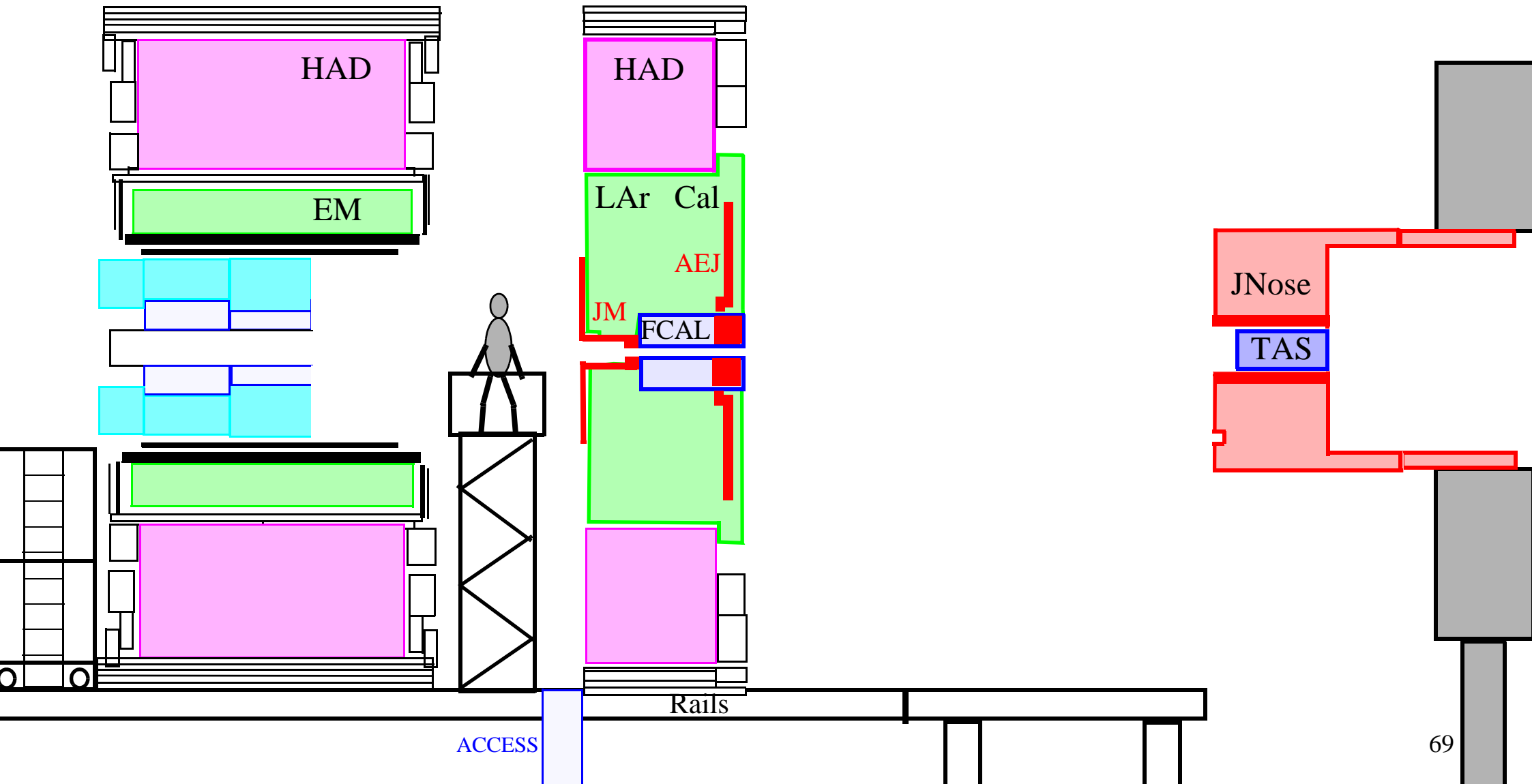

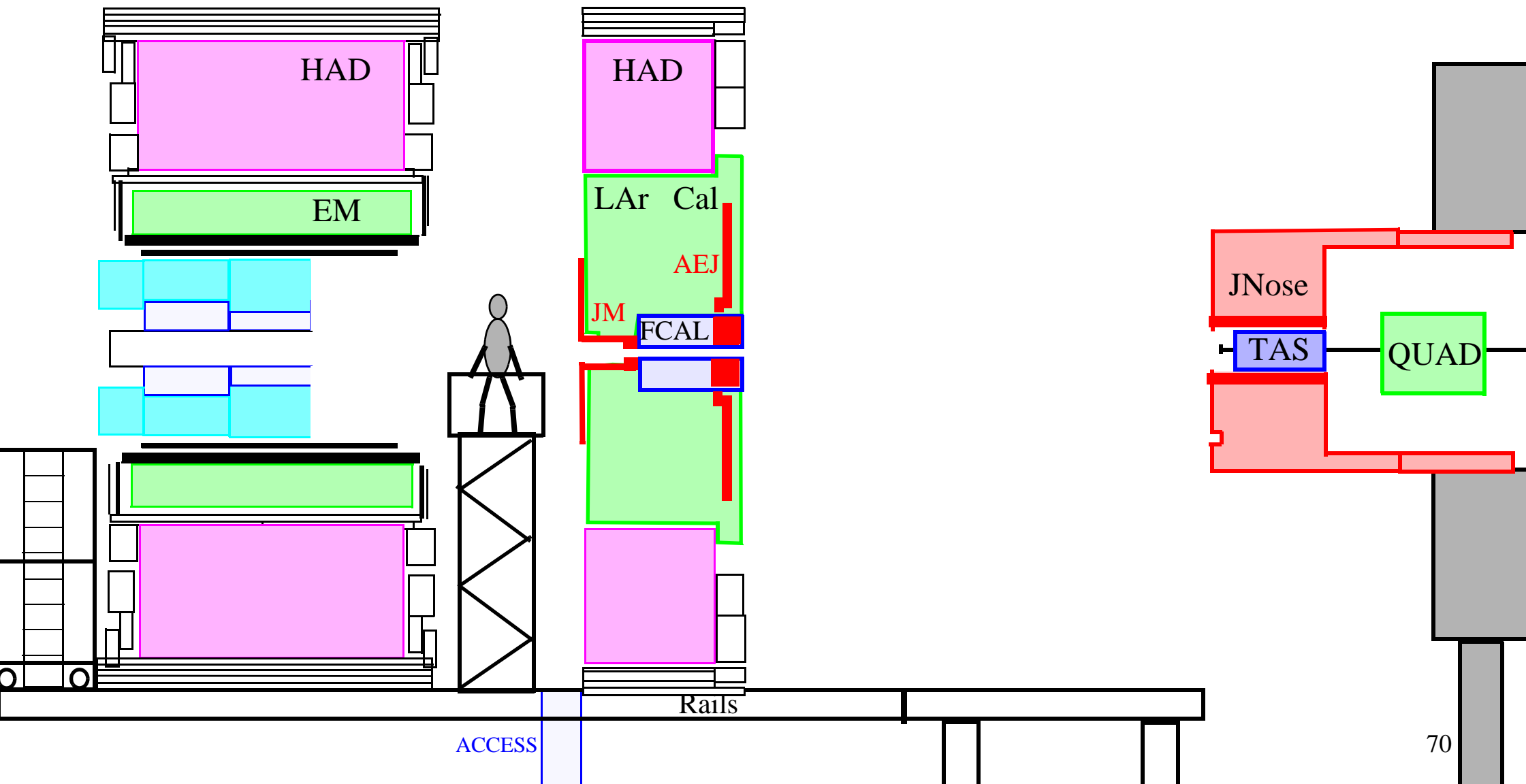

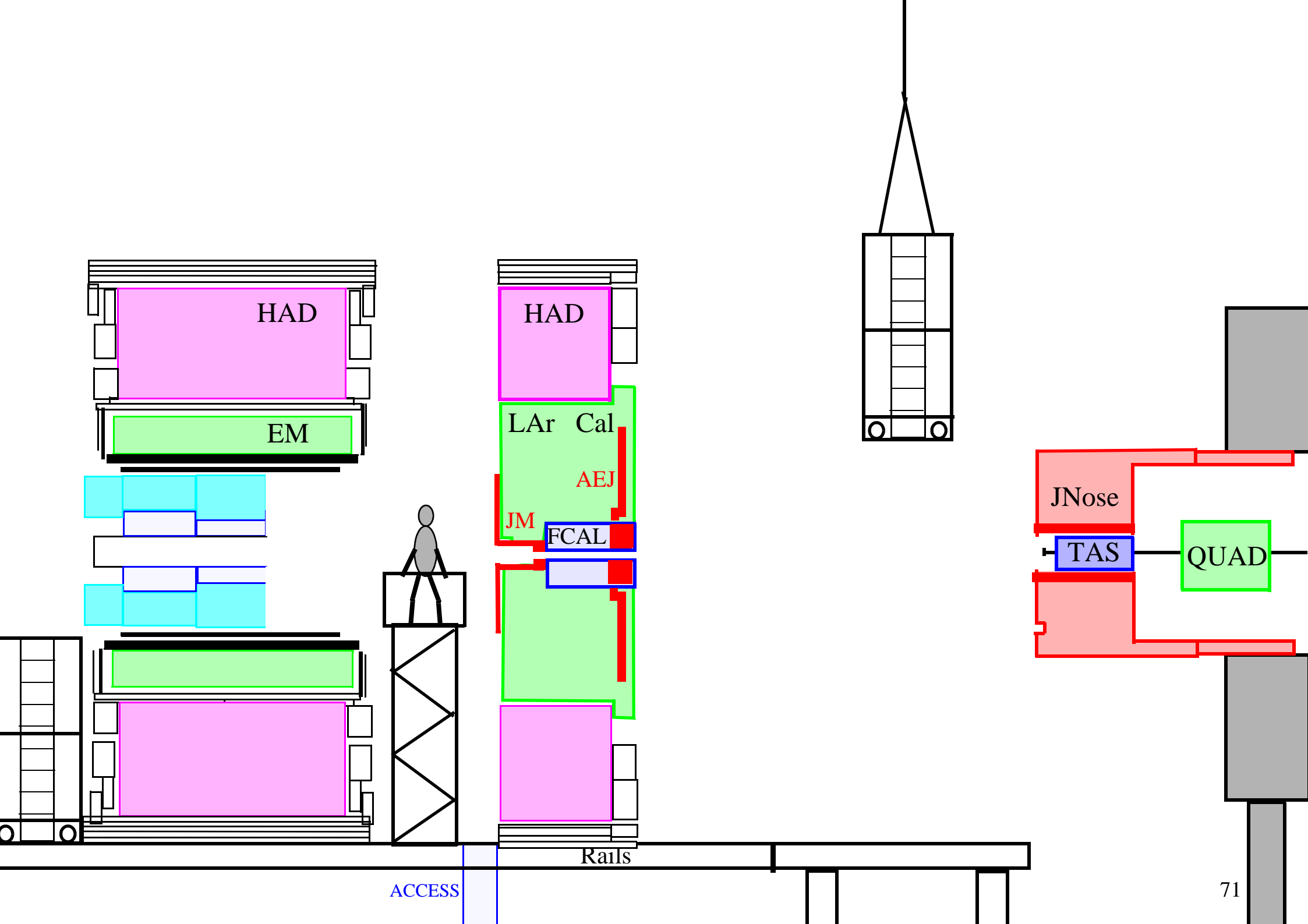

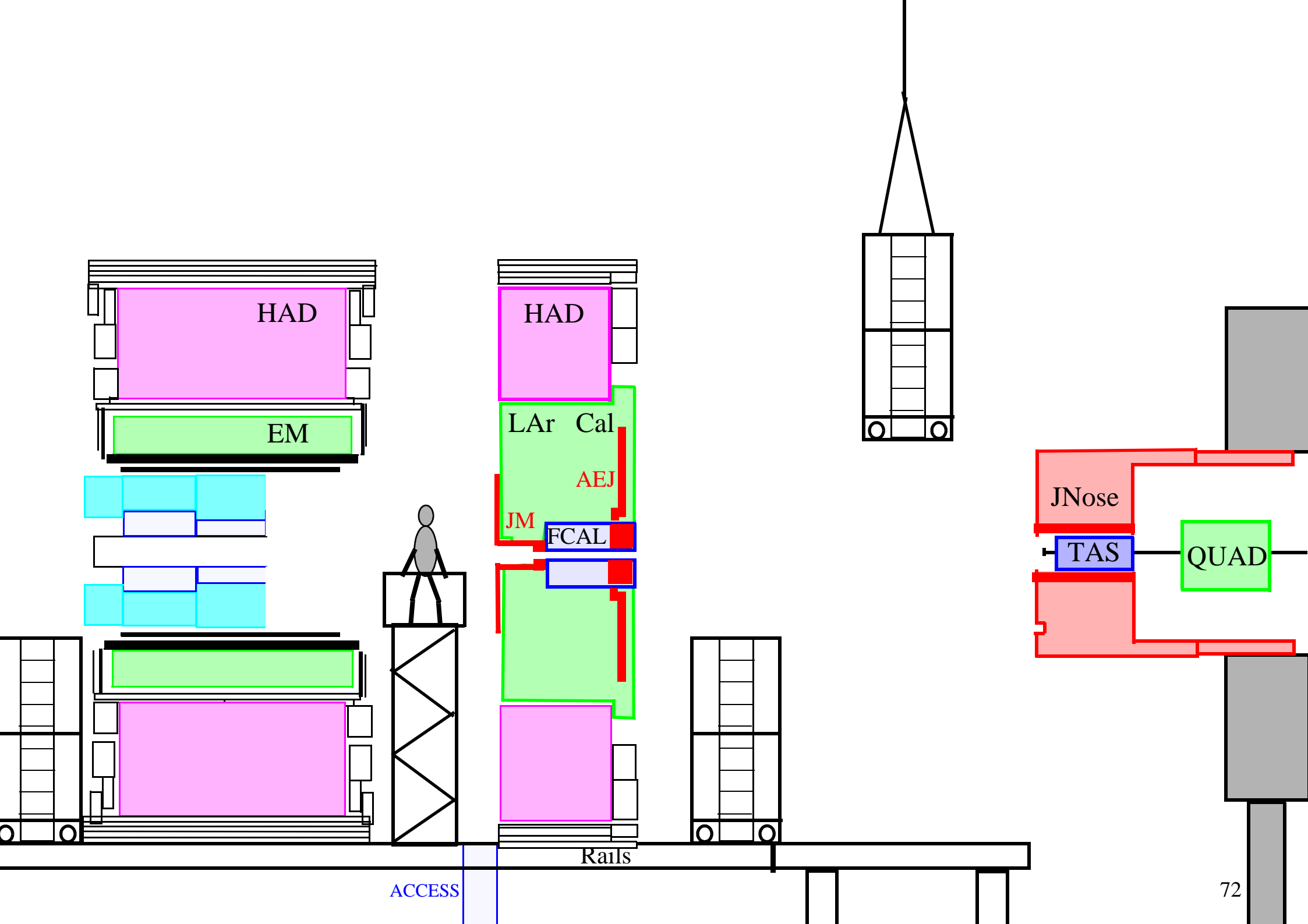

HAD

EM

HAD

LAr Cal

AEJ

JM

FCAL

JNose

TAS

QUAD

Rails

ACCESS

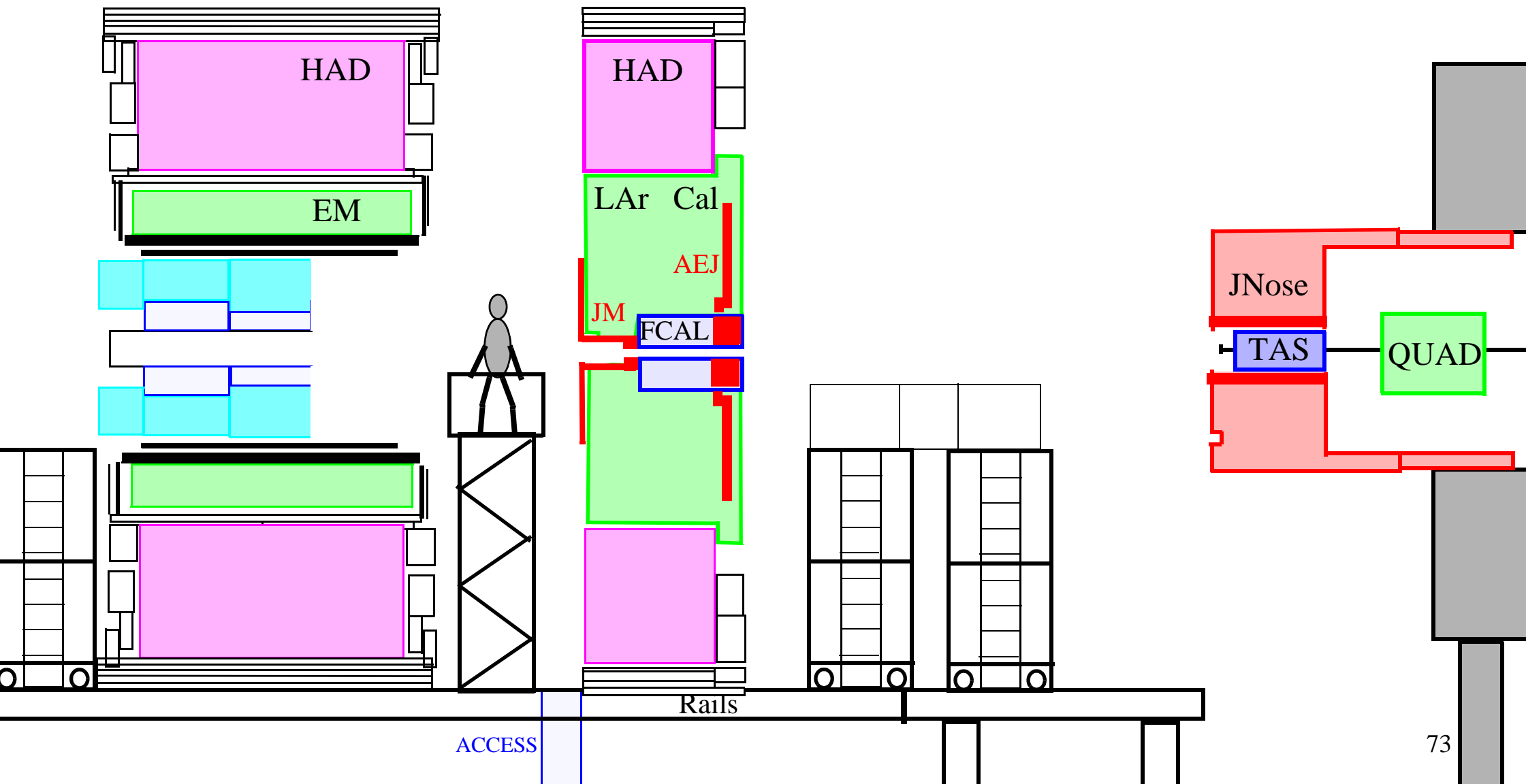

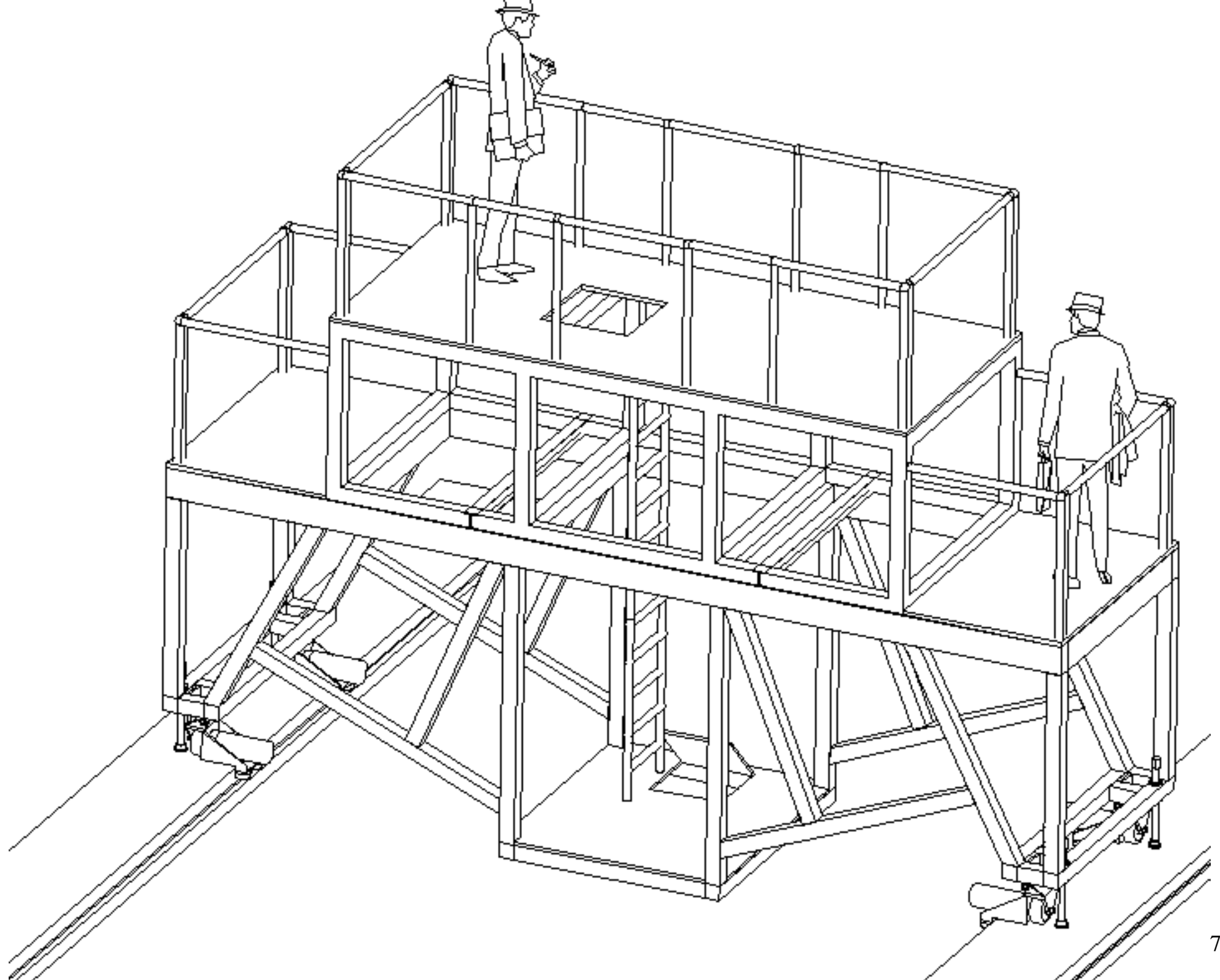

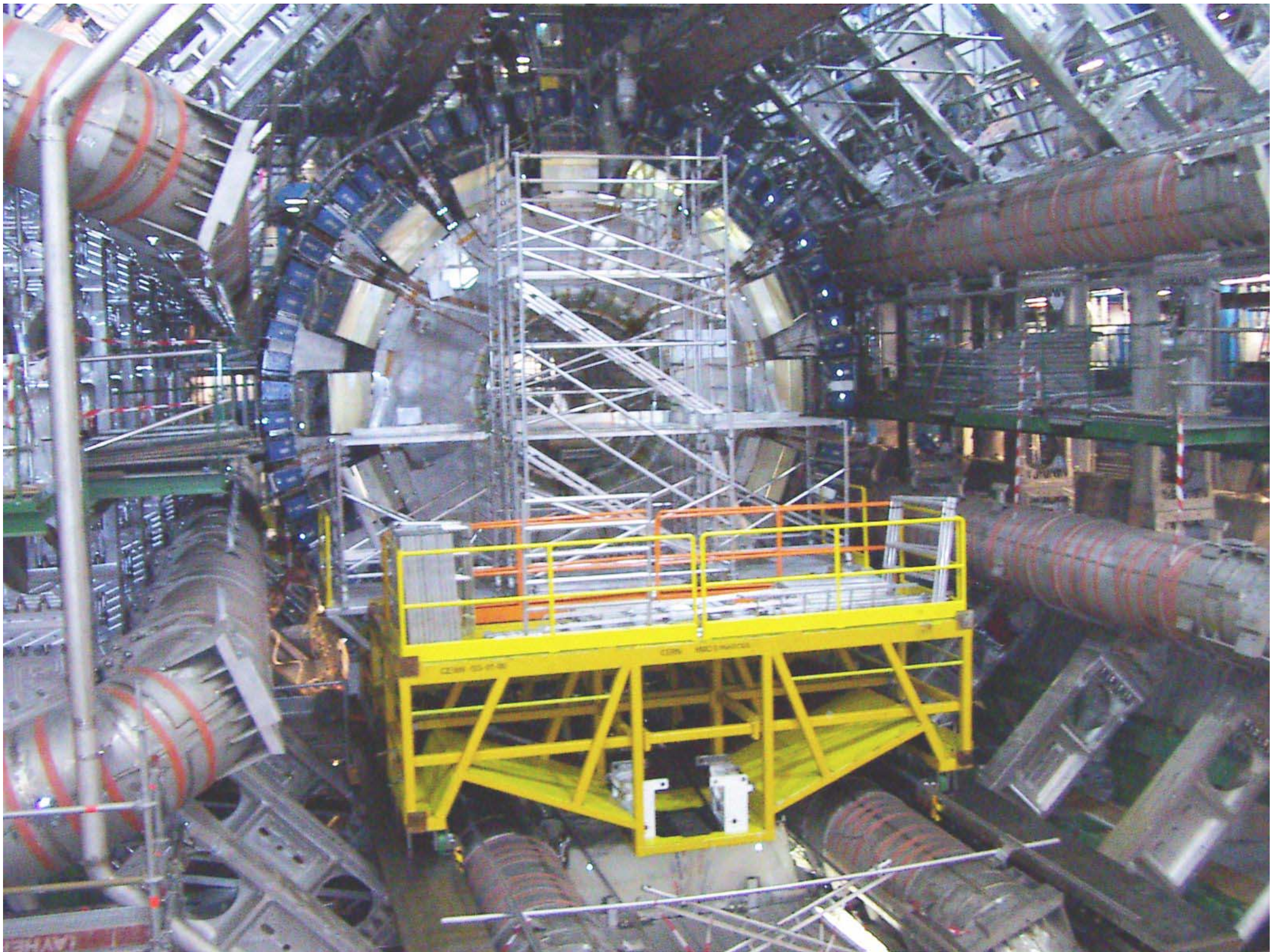

Should this happen at this stage ?
Can it be done from the HS structure ?

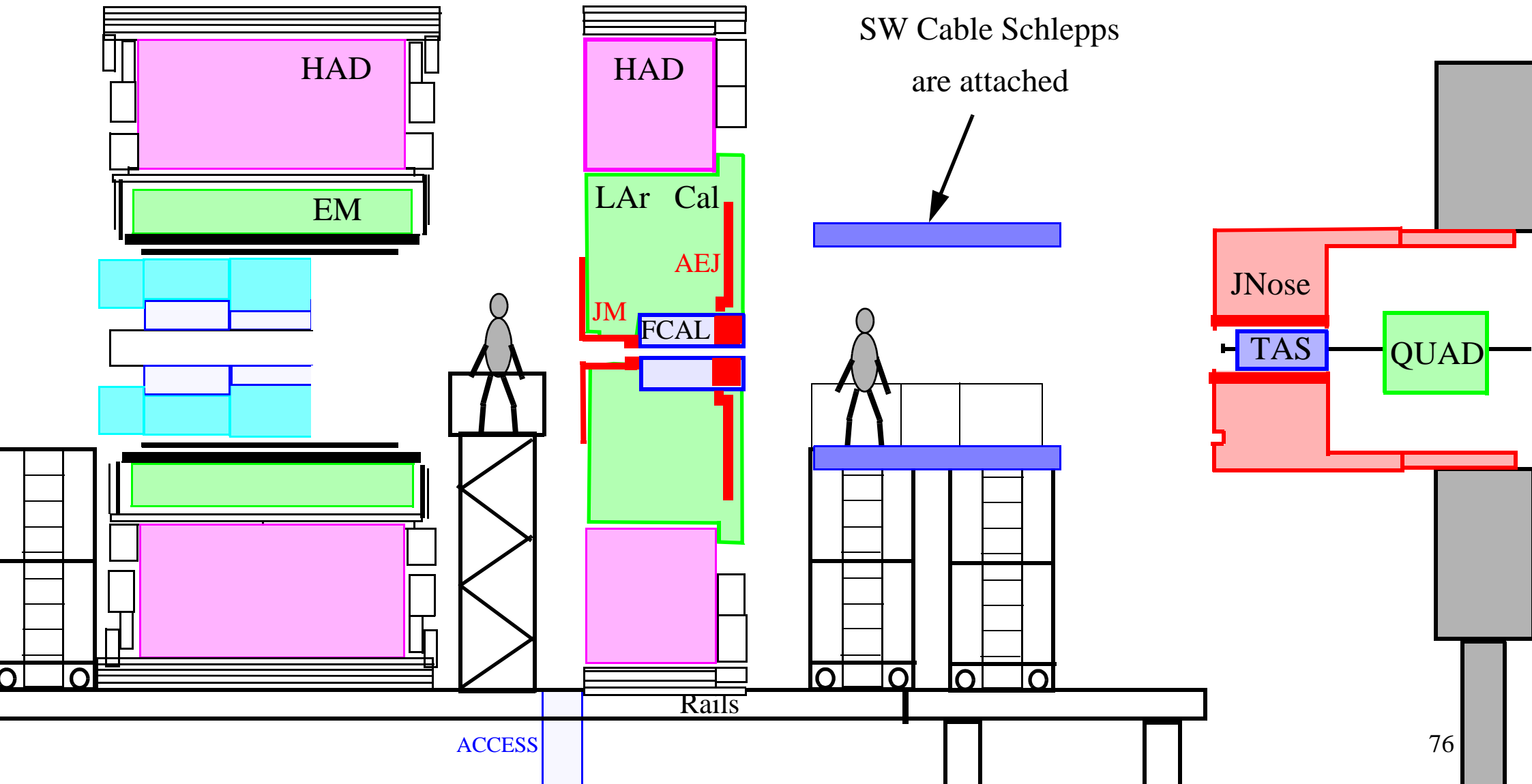

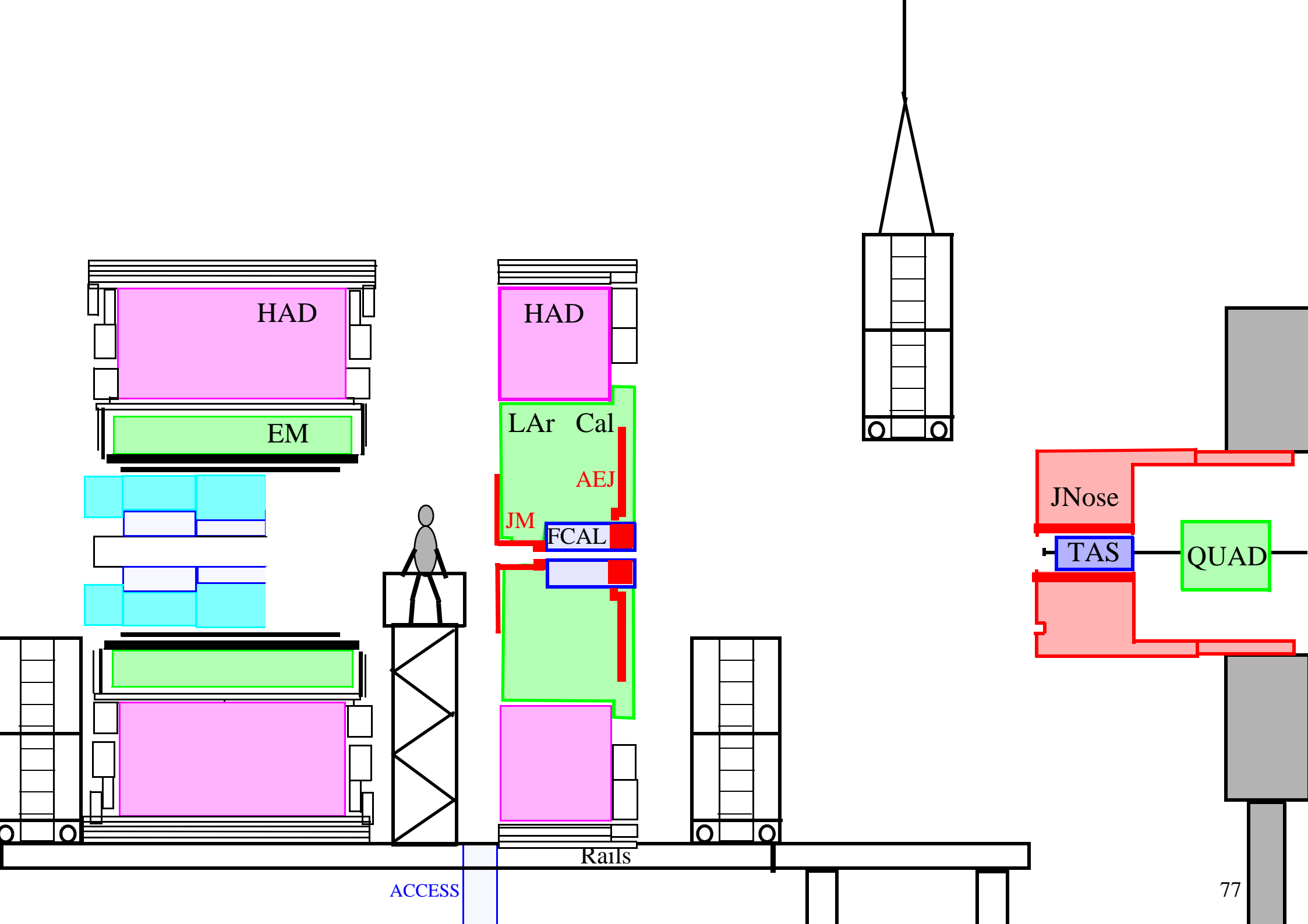

HAD

EM

HAD

LAr Cal

AEJ

JM

FCAL

JNose

TAS

QUAD

Rails

ACCESS

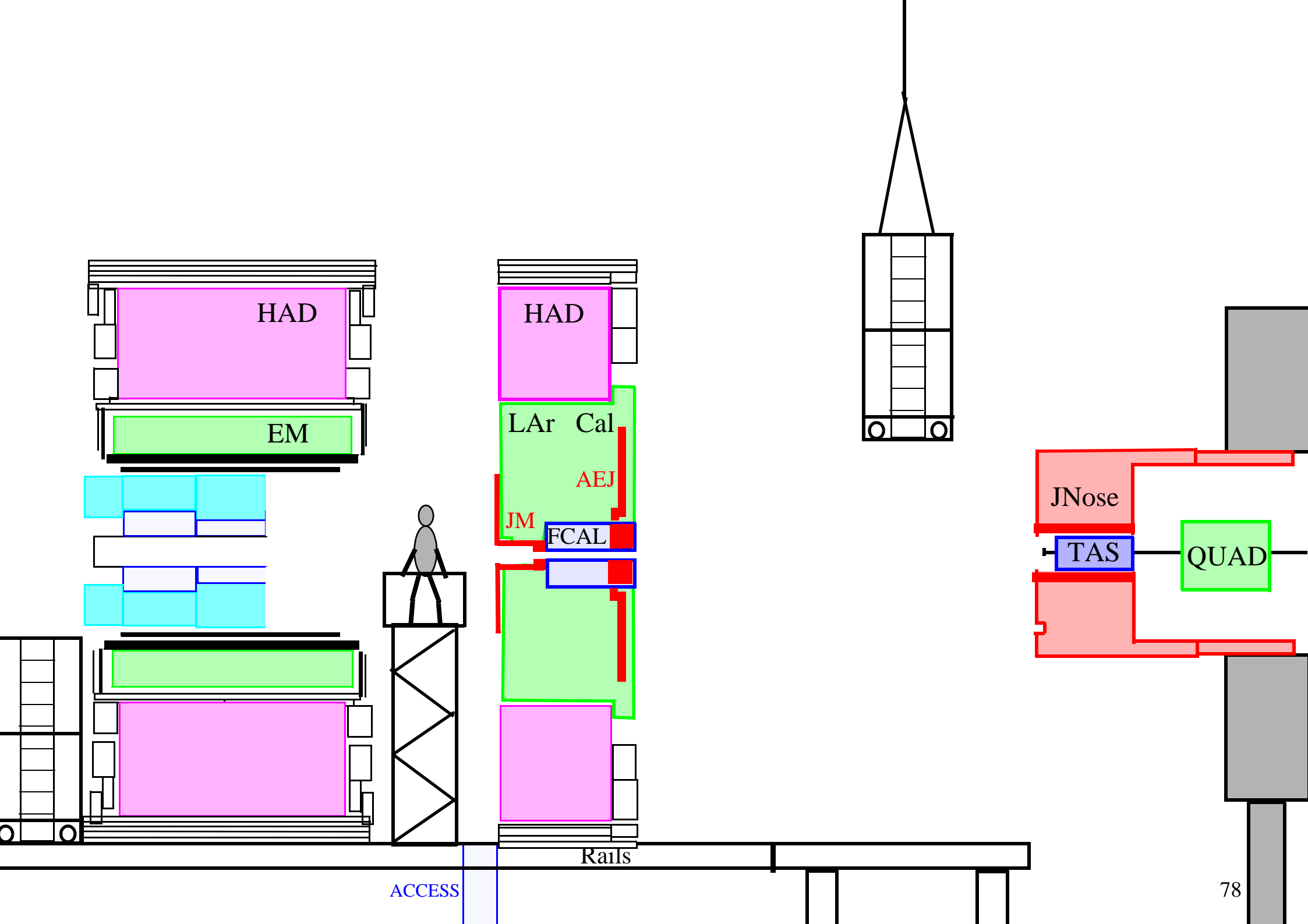

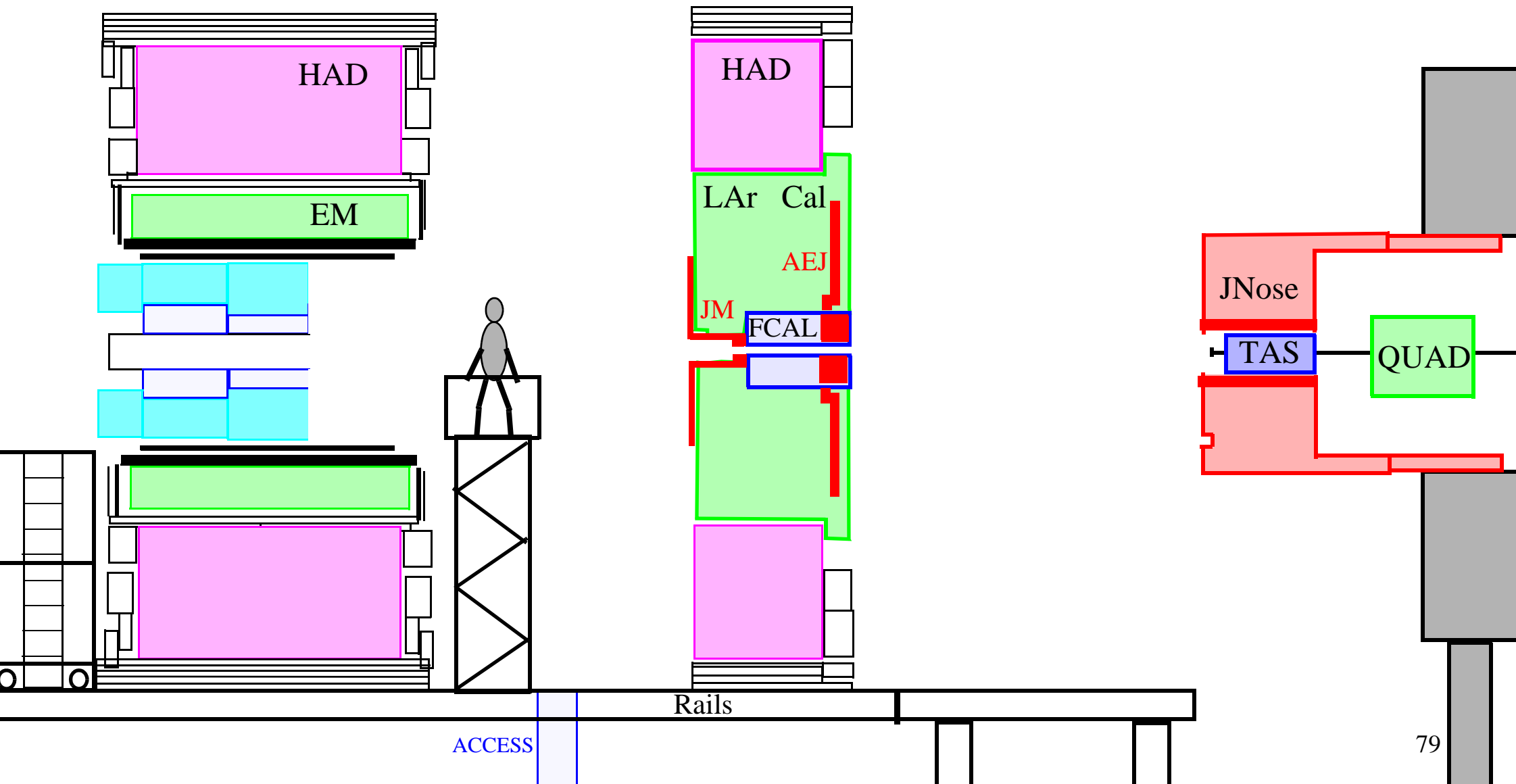

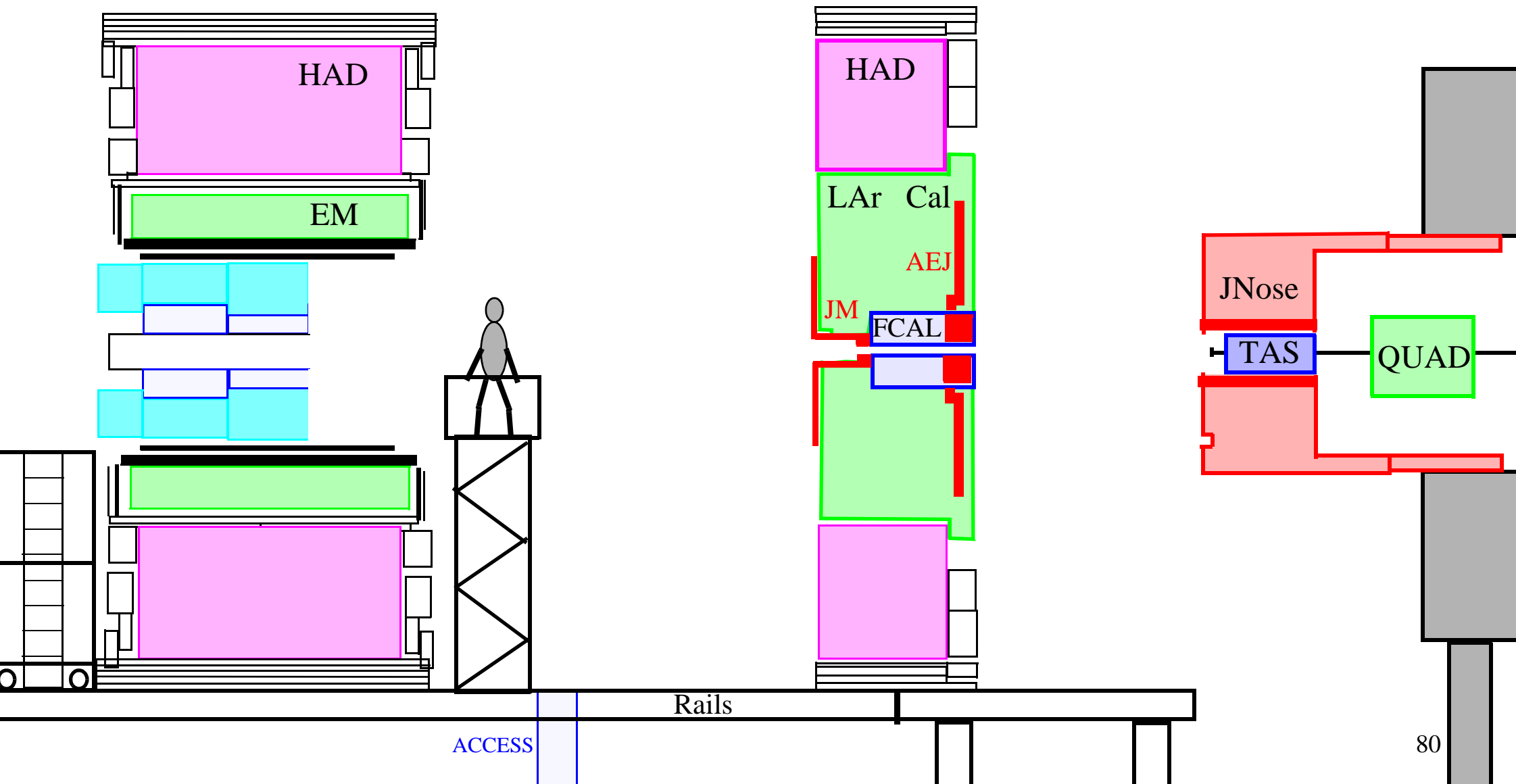

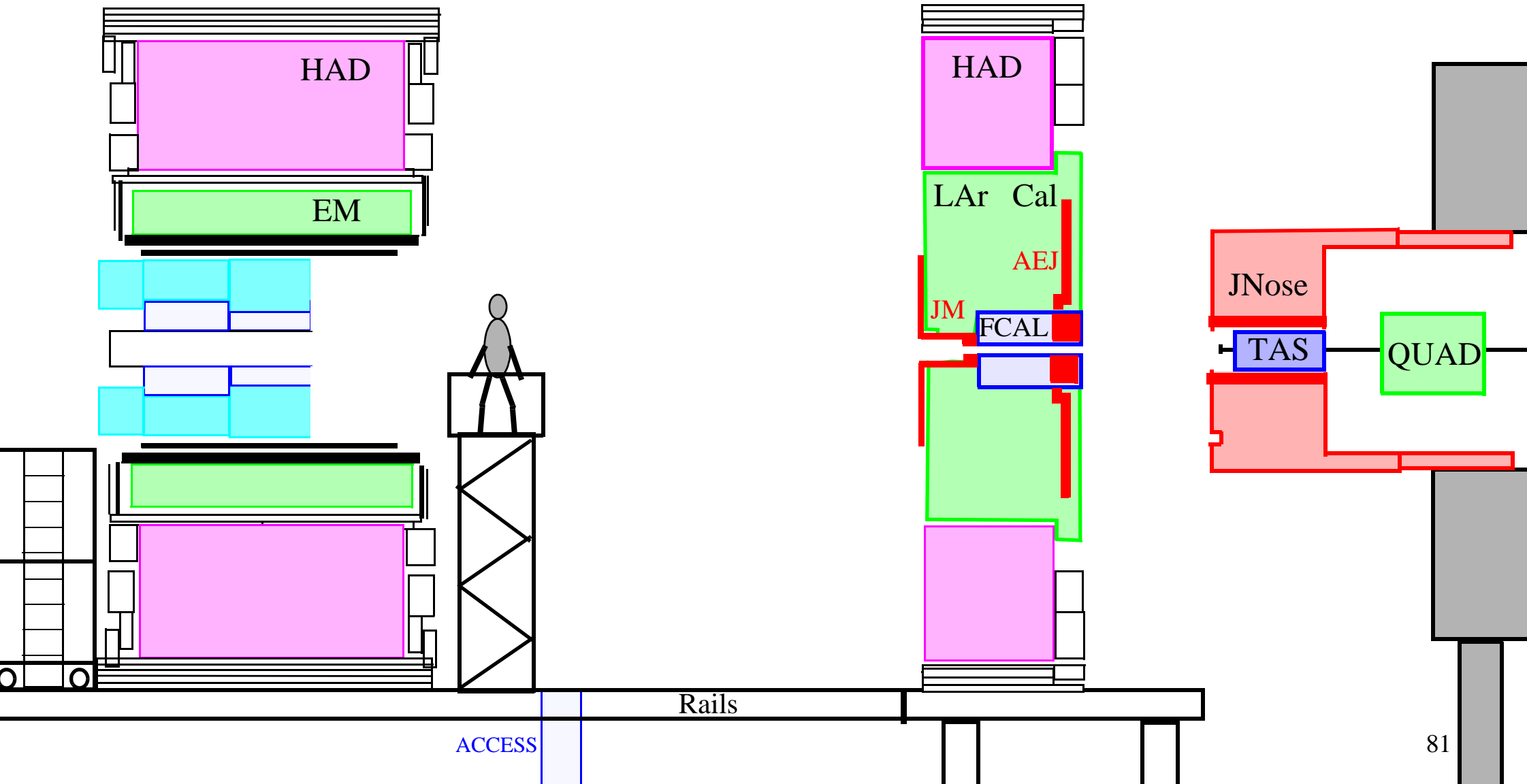

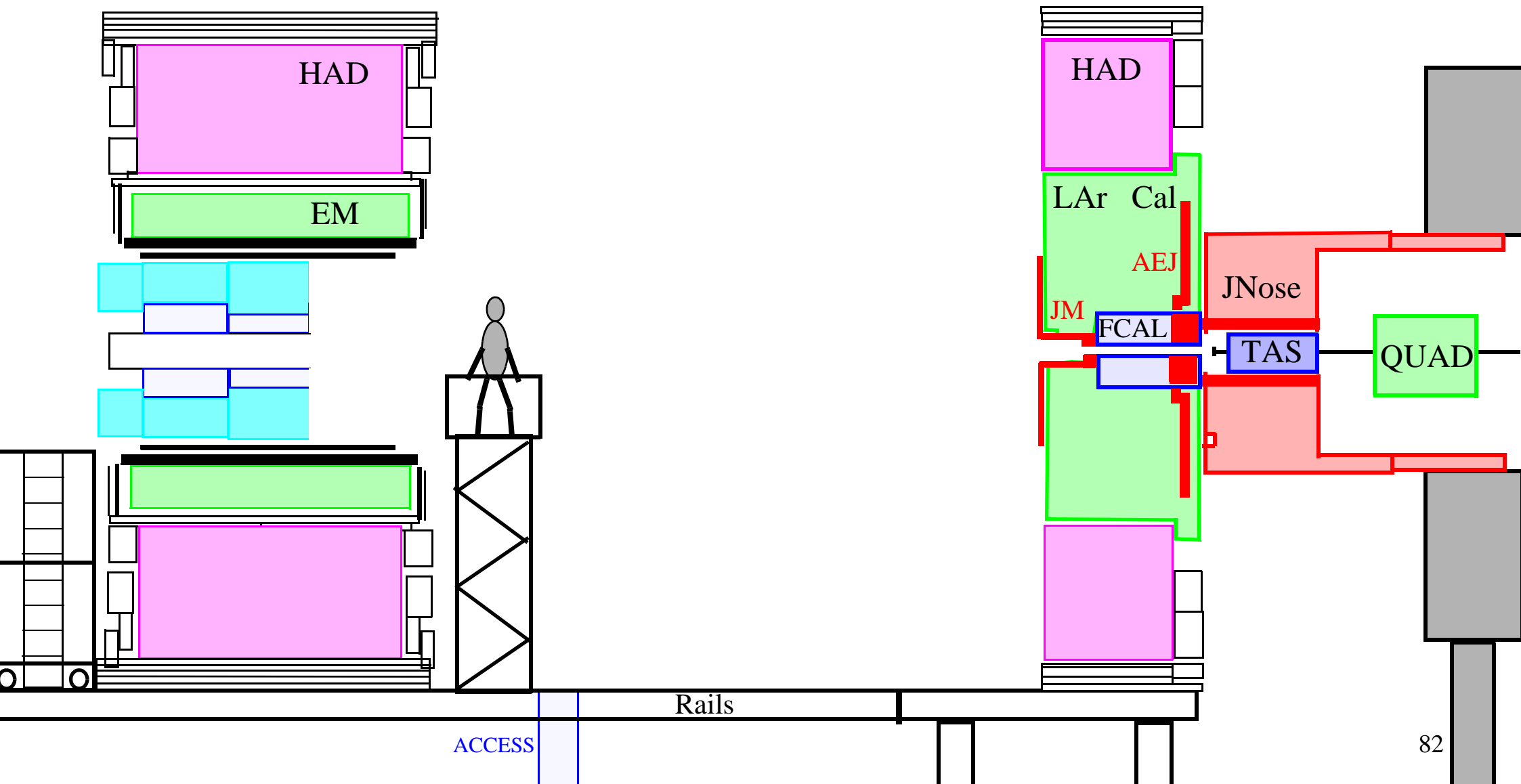

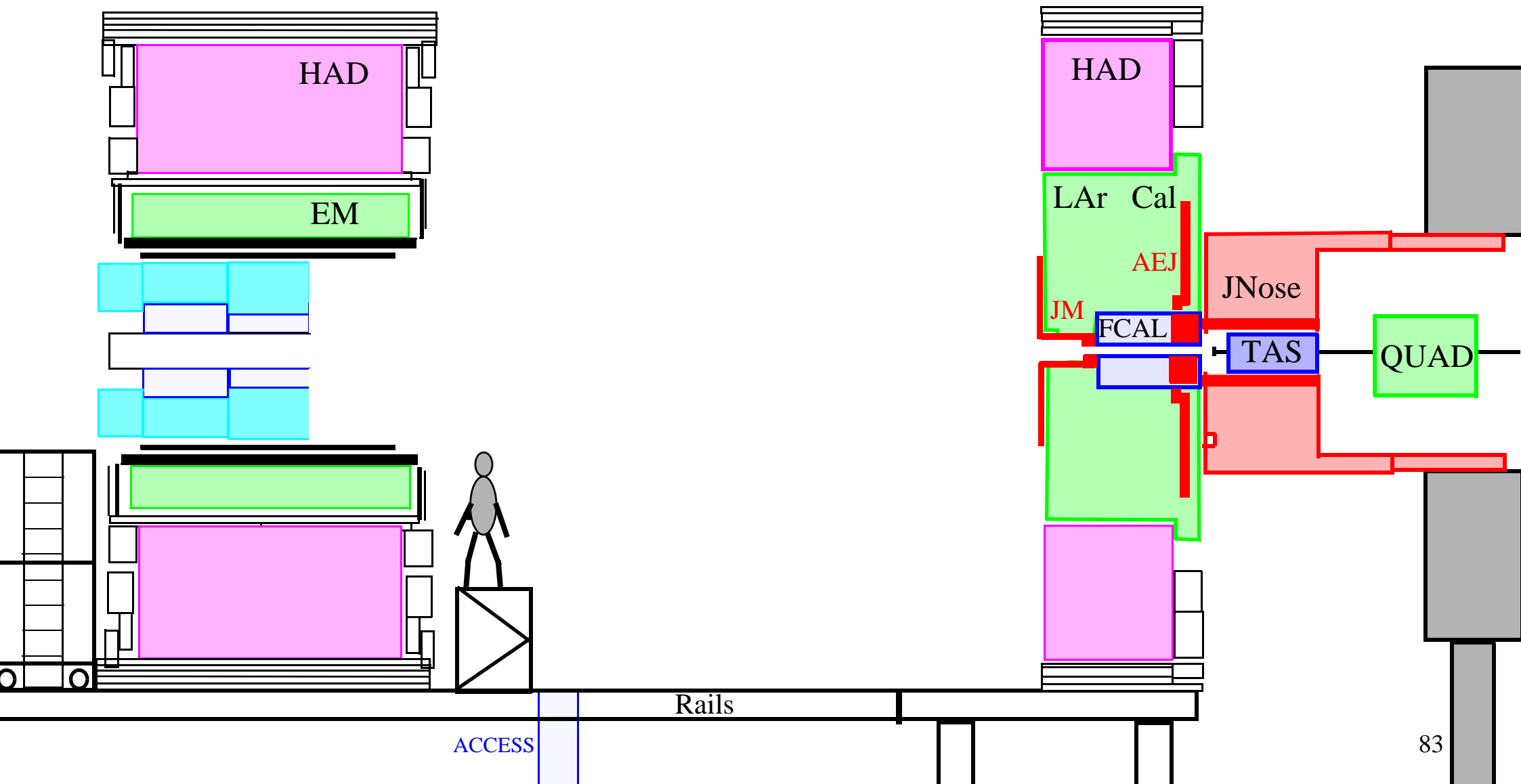

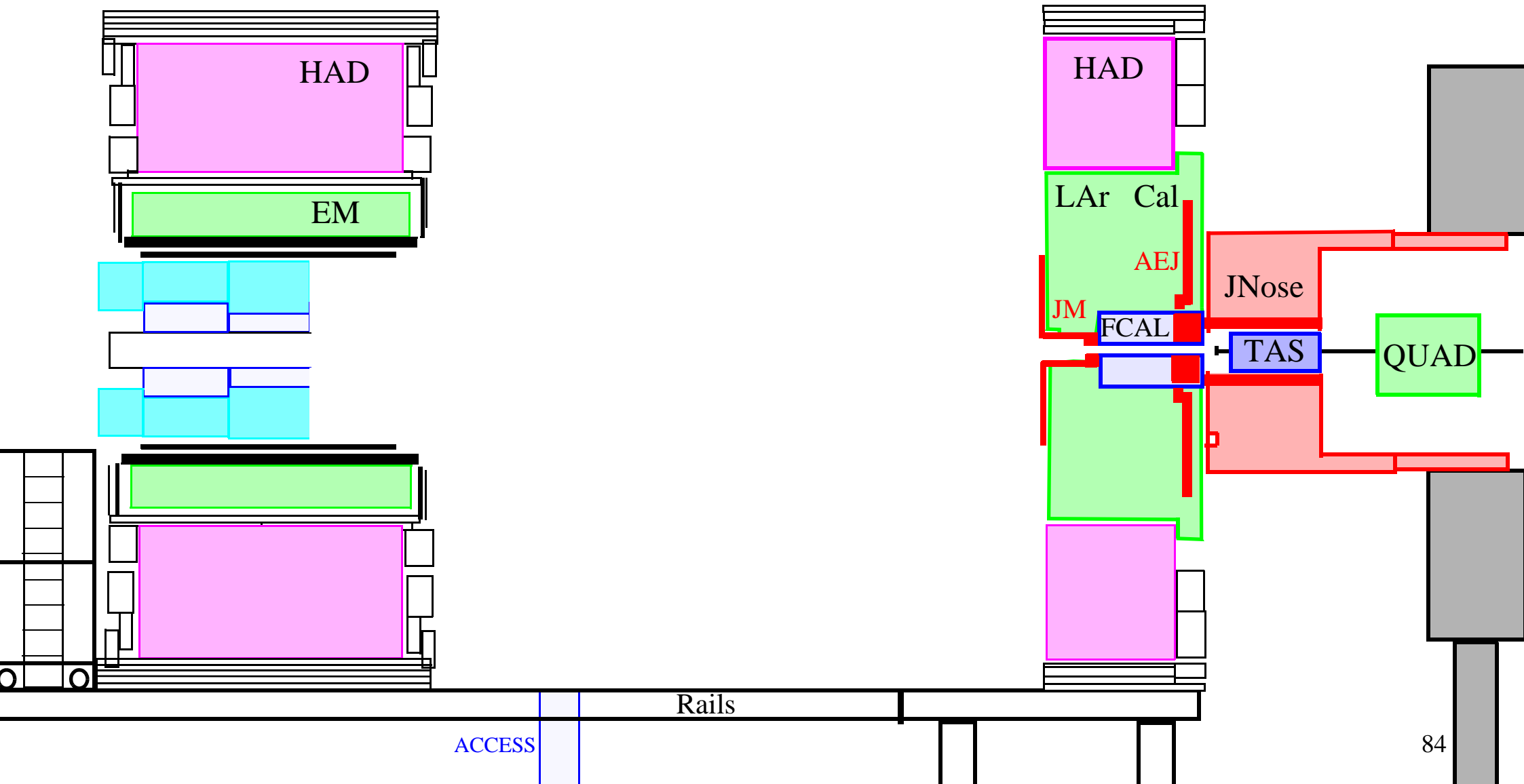

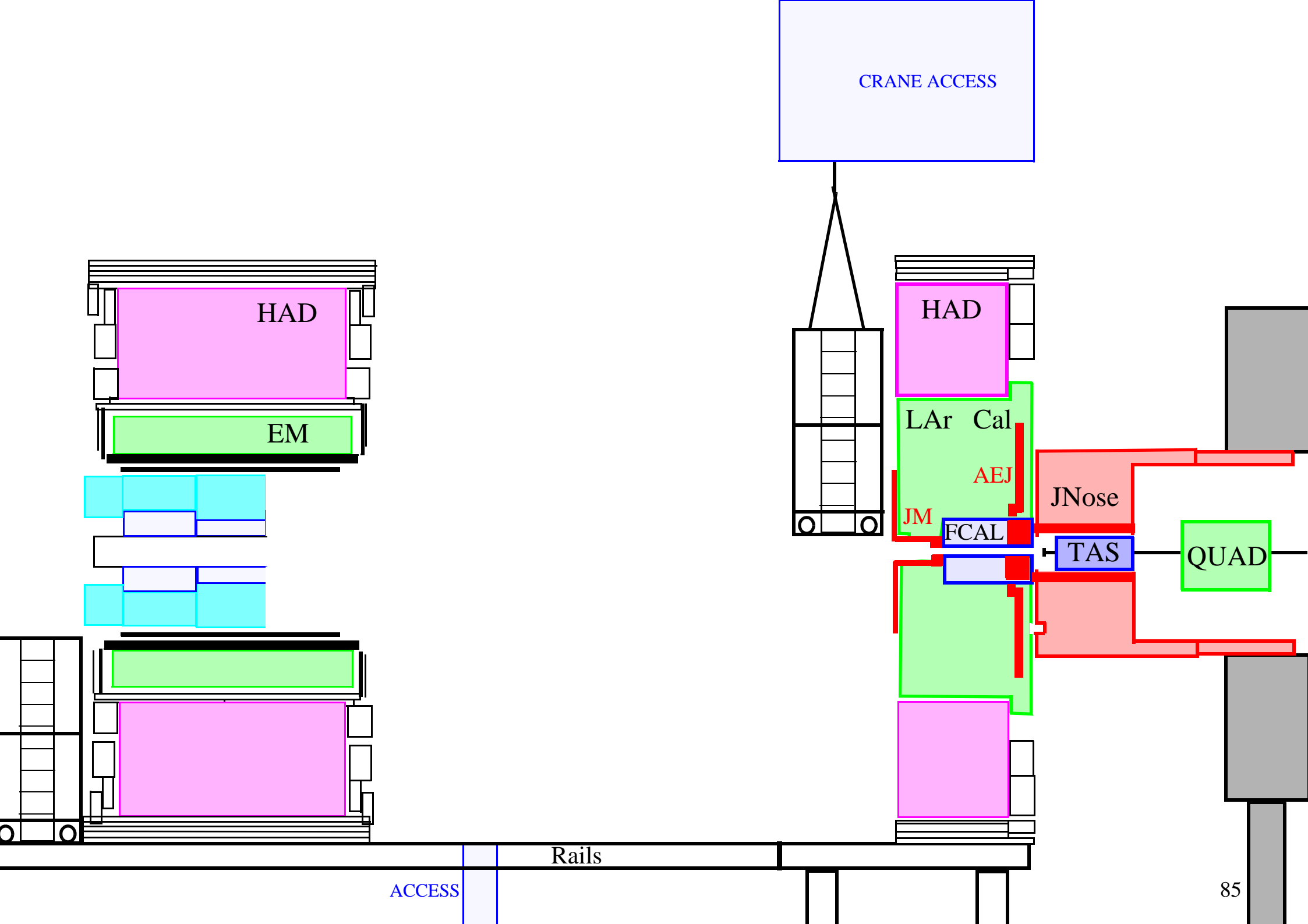

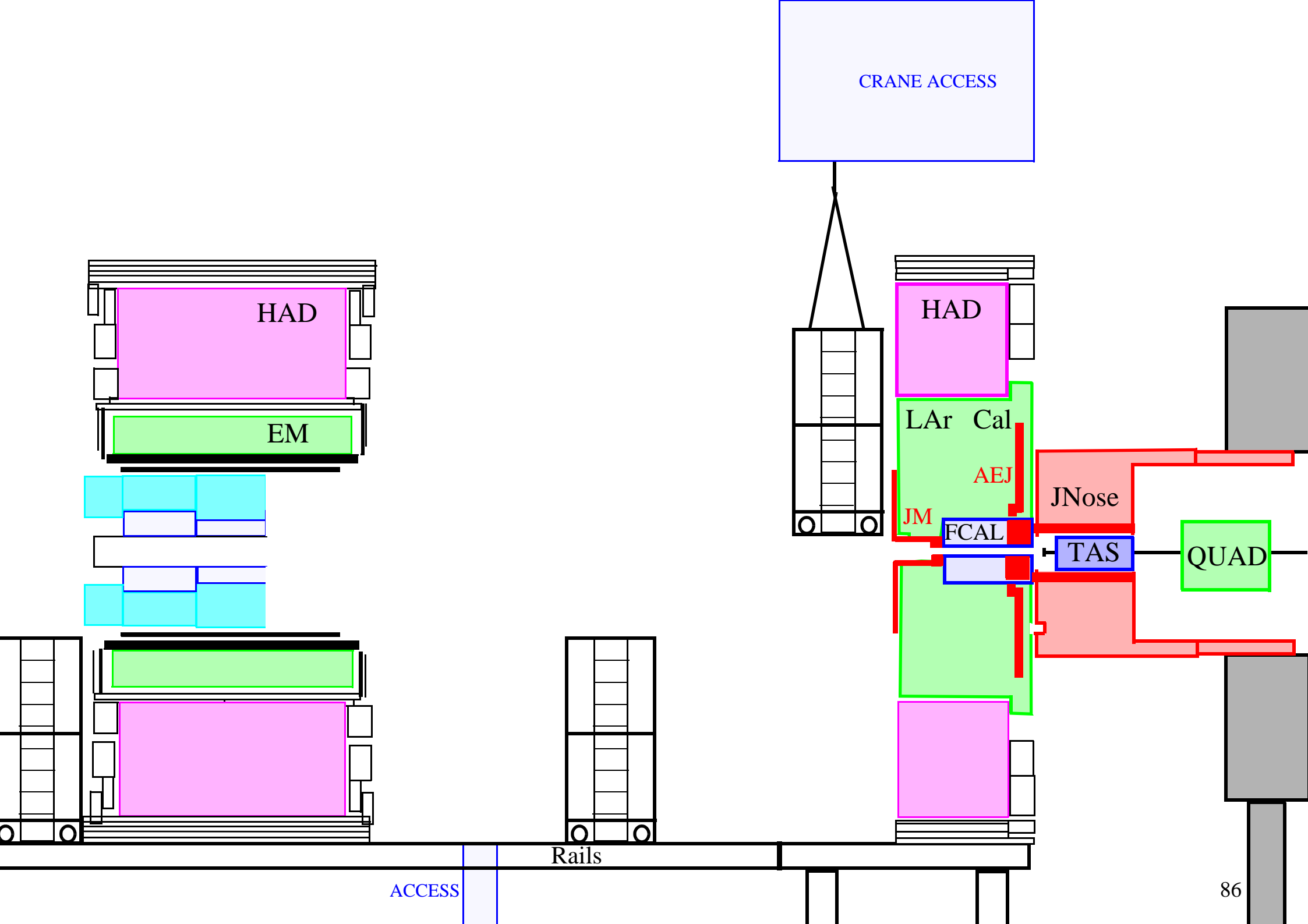

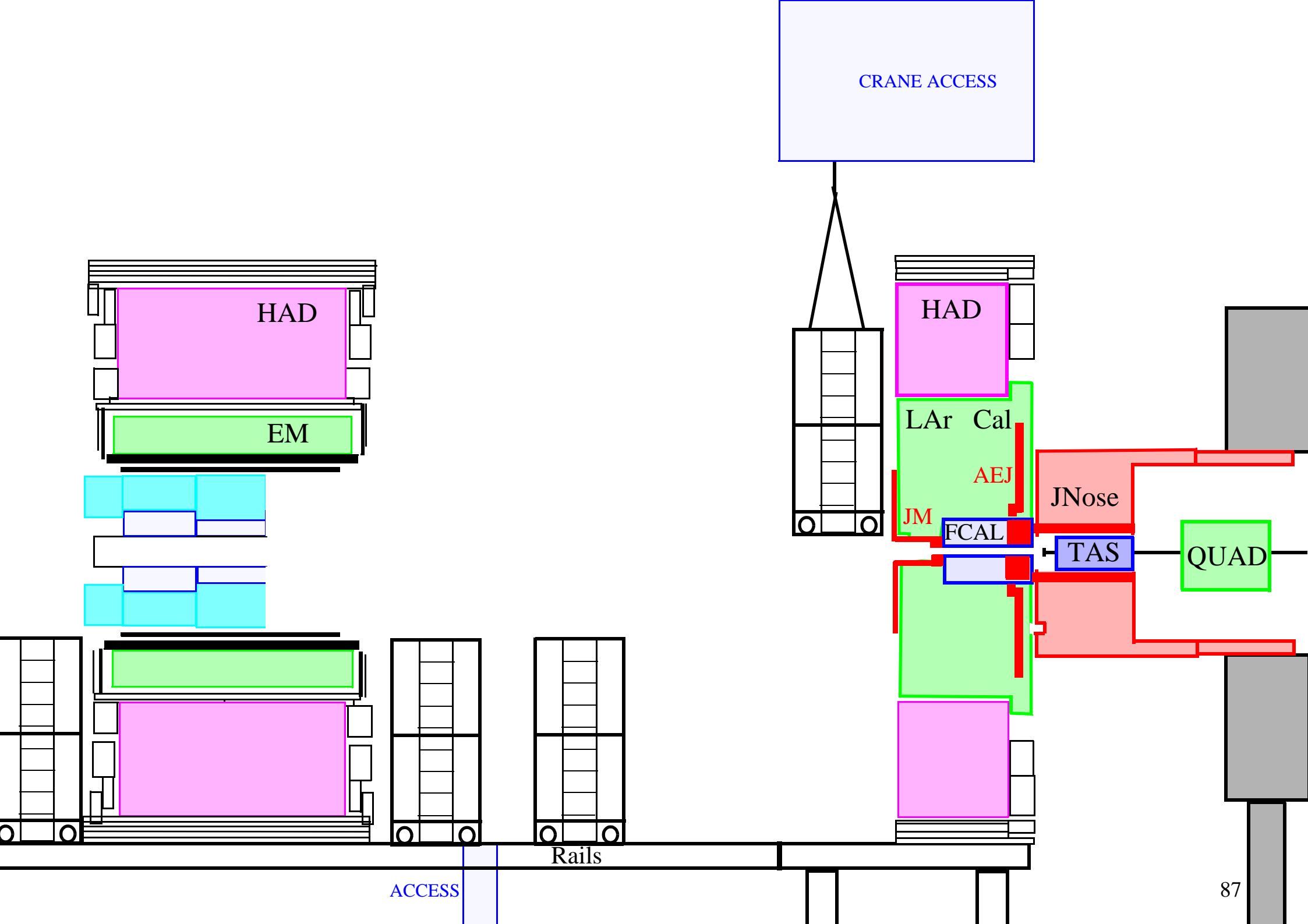

CRANE ACCESS

HAD

EM

HAD

LAr Cal

AEJ

JM

FCAL

JNose

TAS

QUAD

Rails

ACCESS

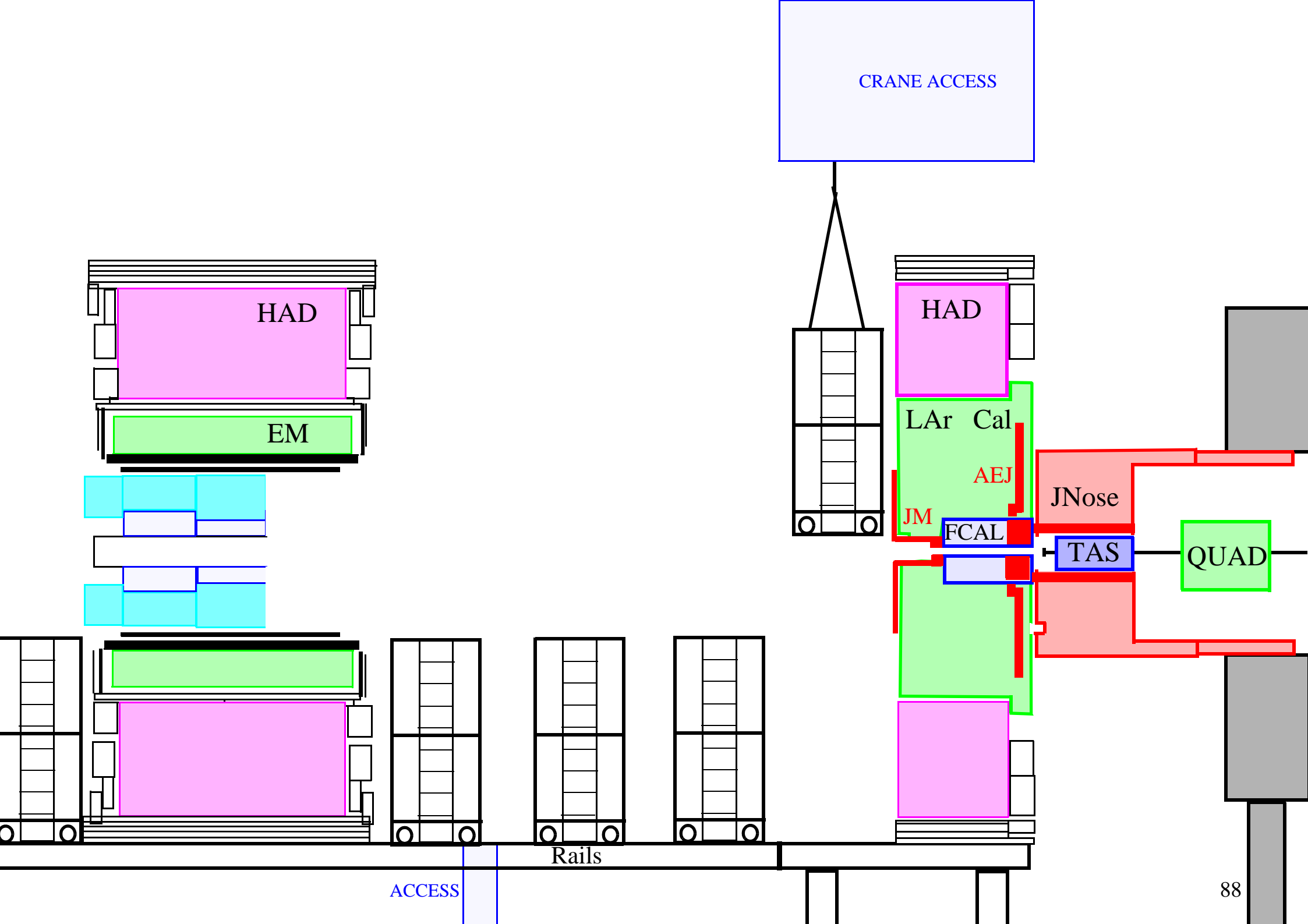

CRANE ACCESS

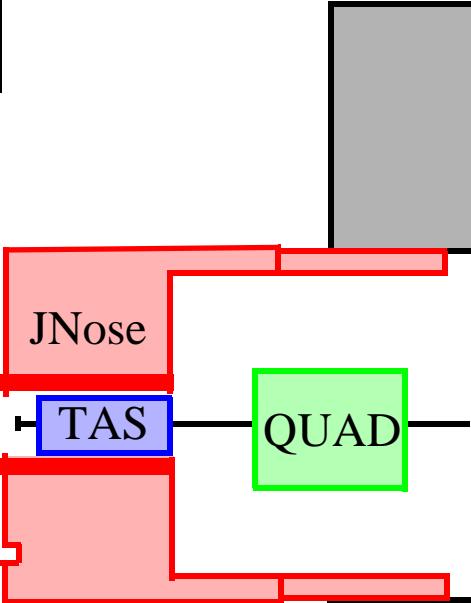
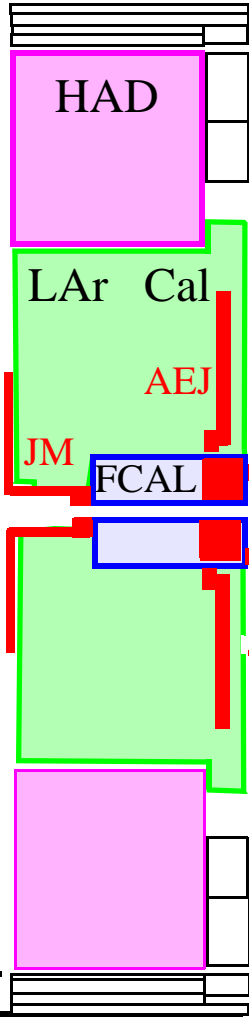
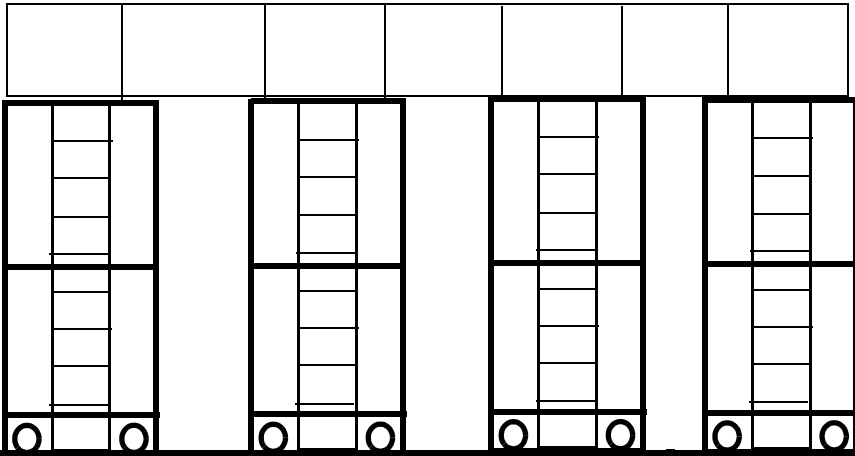
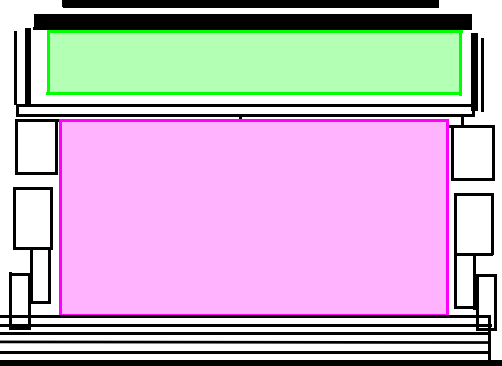
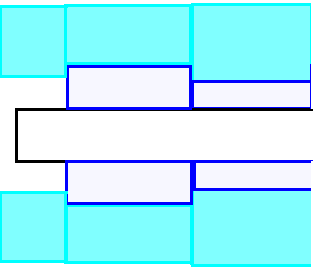
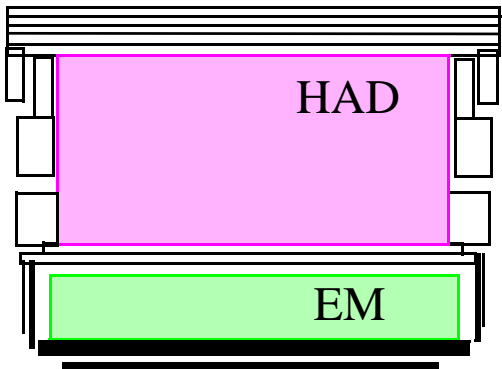

ACCESS

Rails

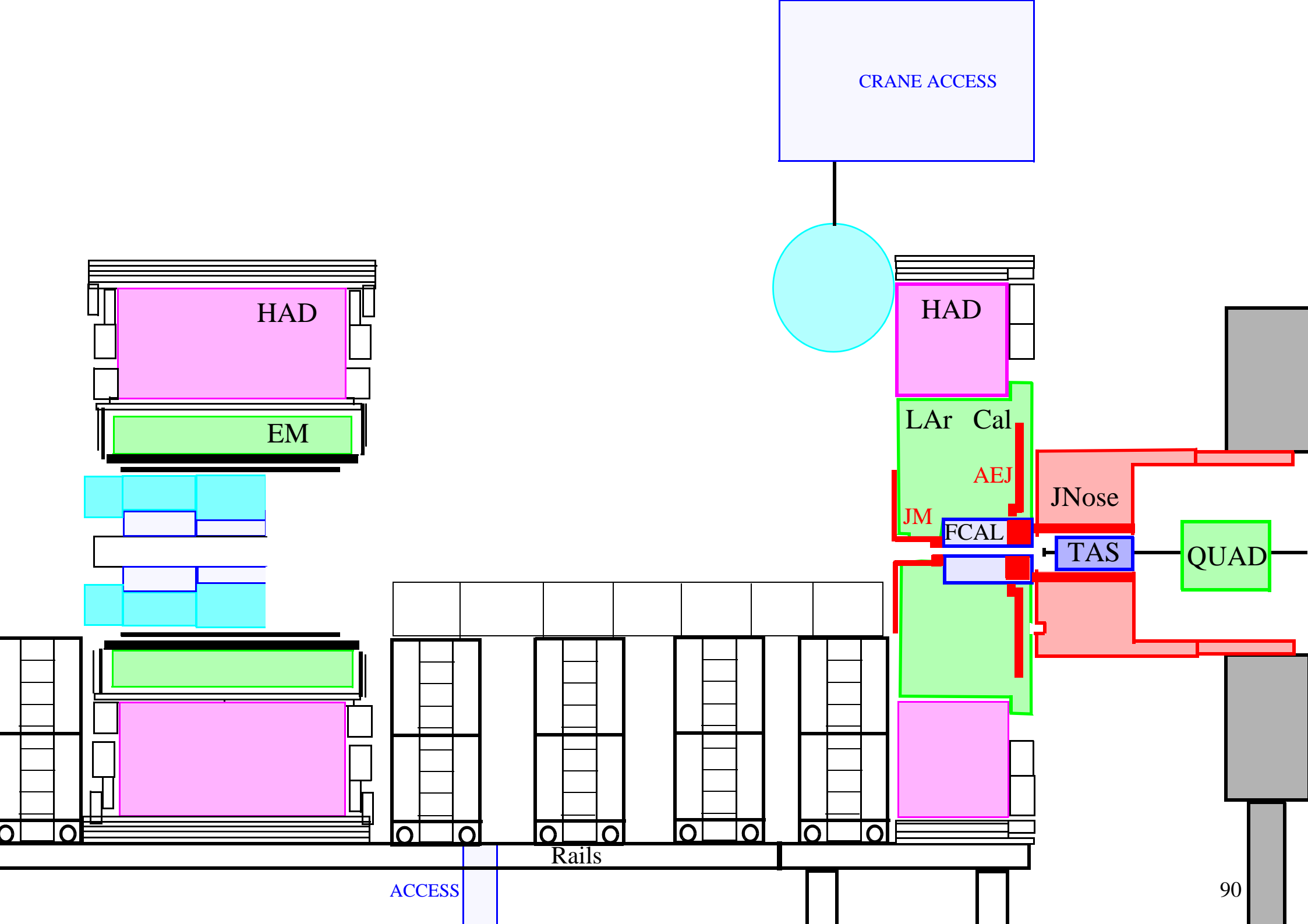

CRANE ACCESS

HAD

EM

HAD

LAr Cal

AEJ

JM

FCAL

JNose

TAS

QUAD

Rails

ACCESS

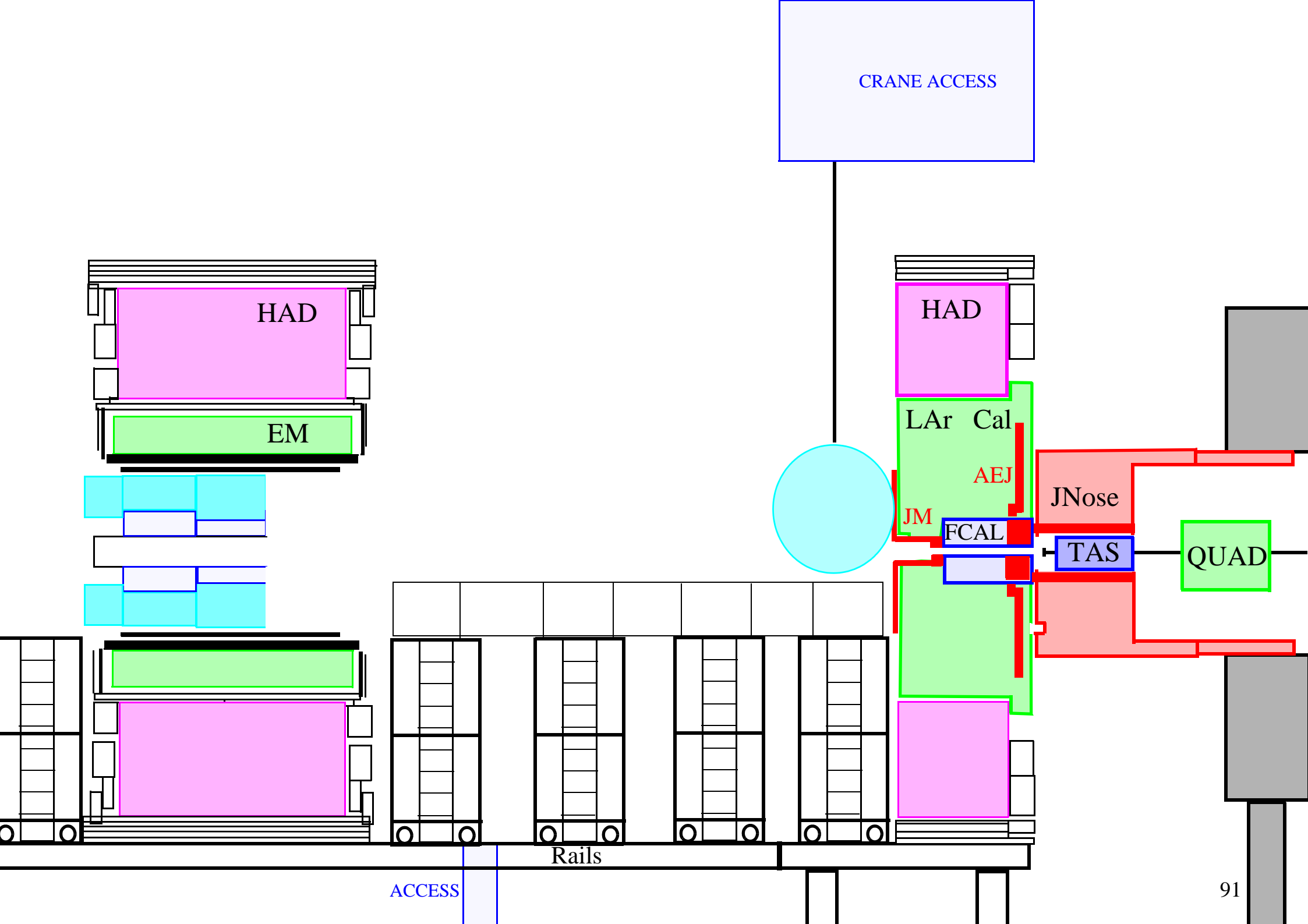

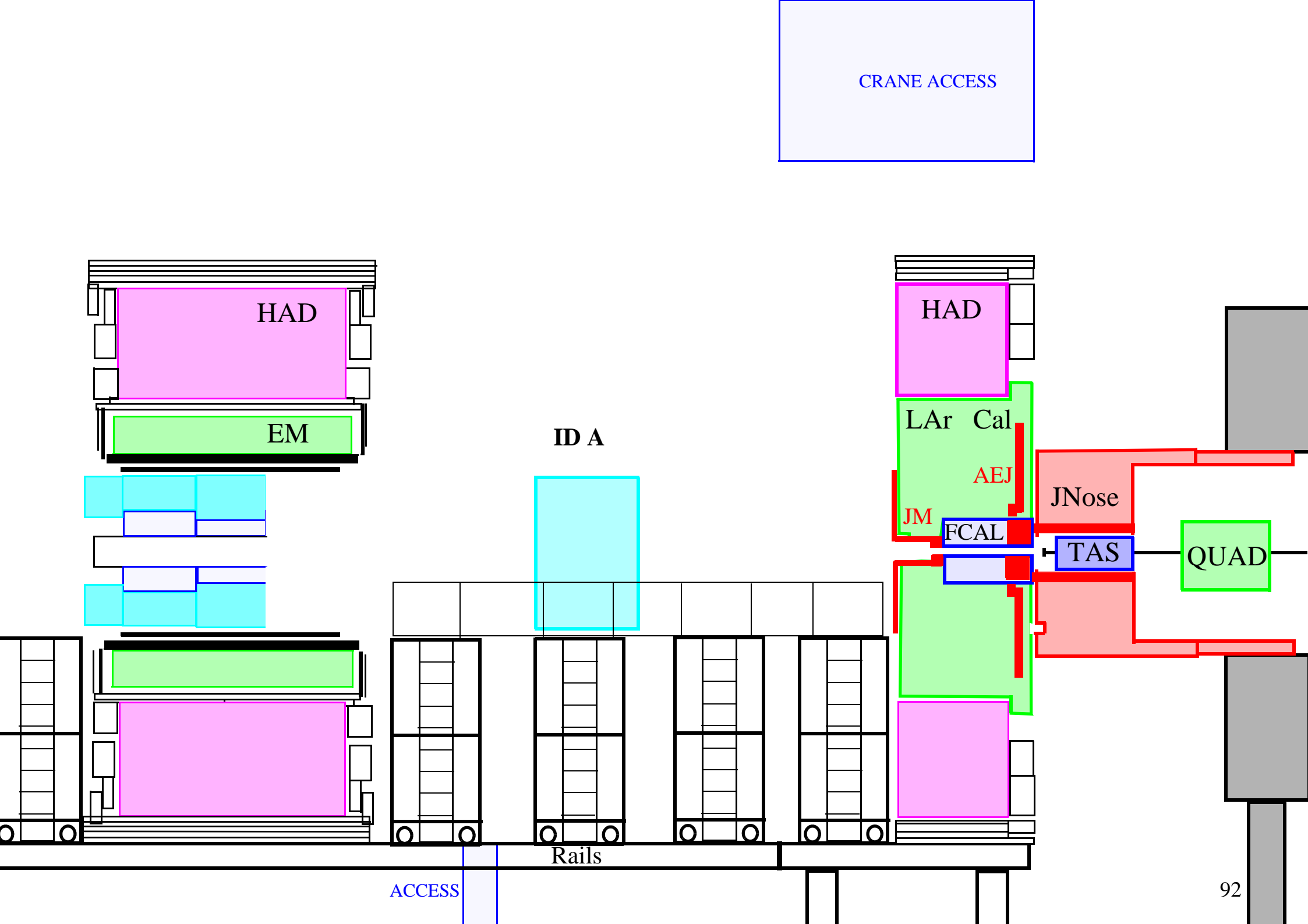

CRANE ACCESS

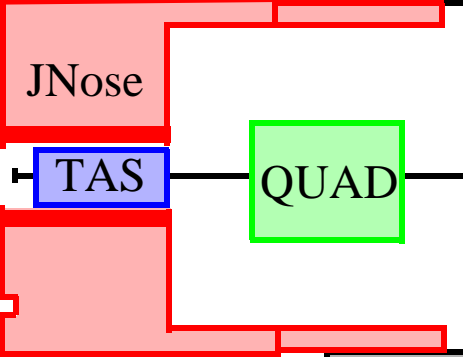
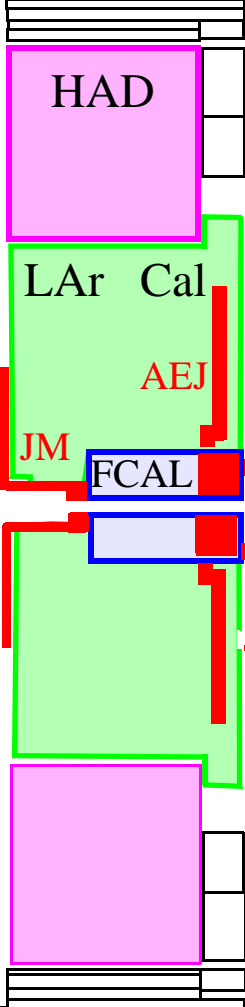
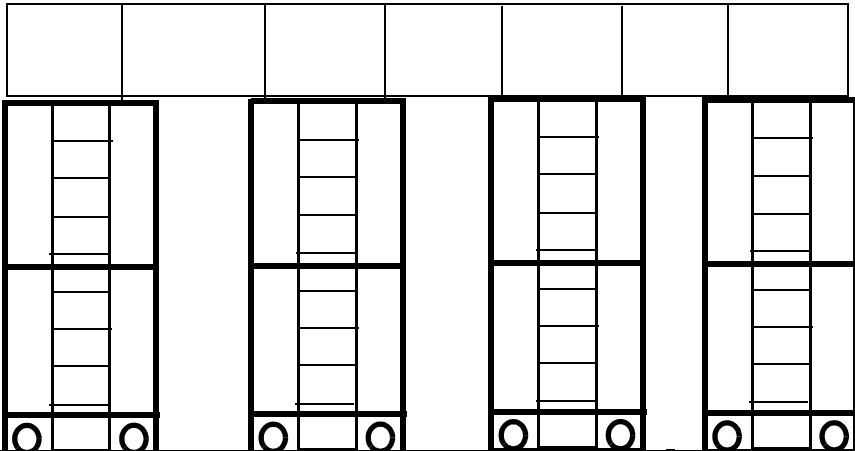
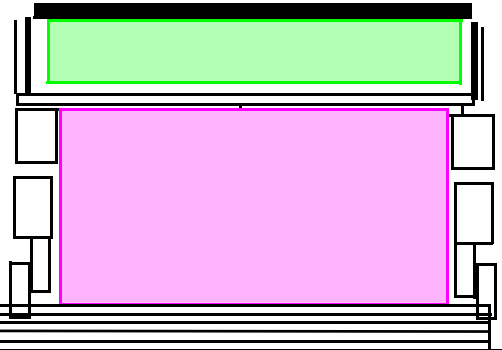
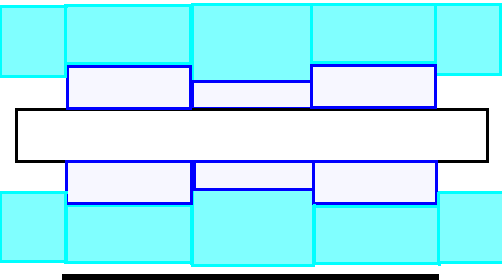
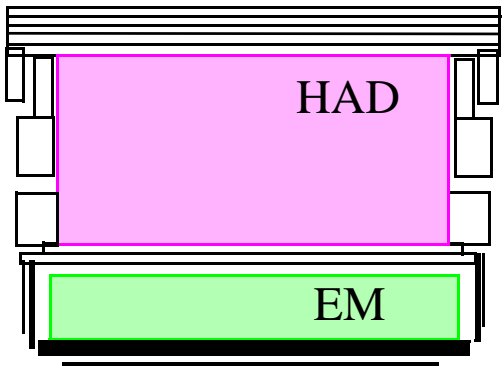

Rails

ACCESS

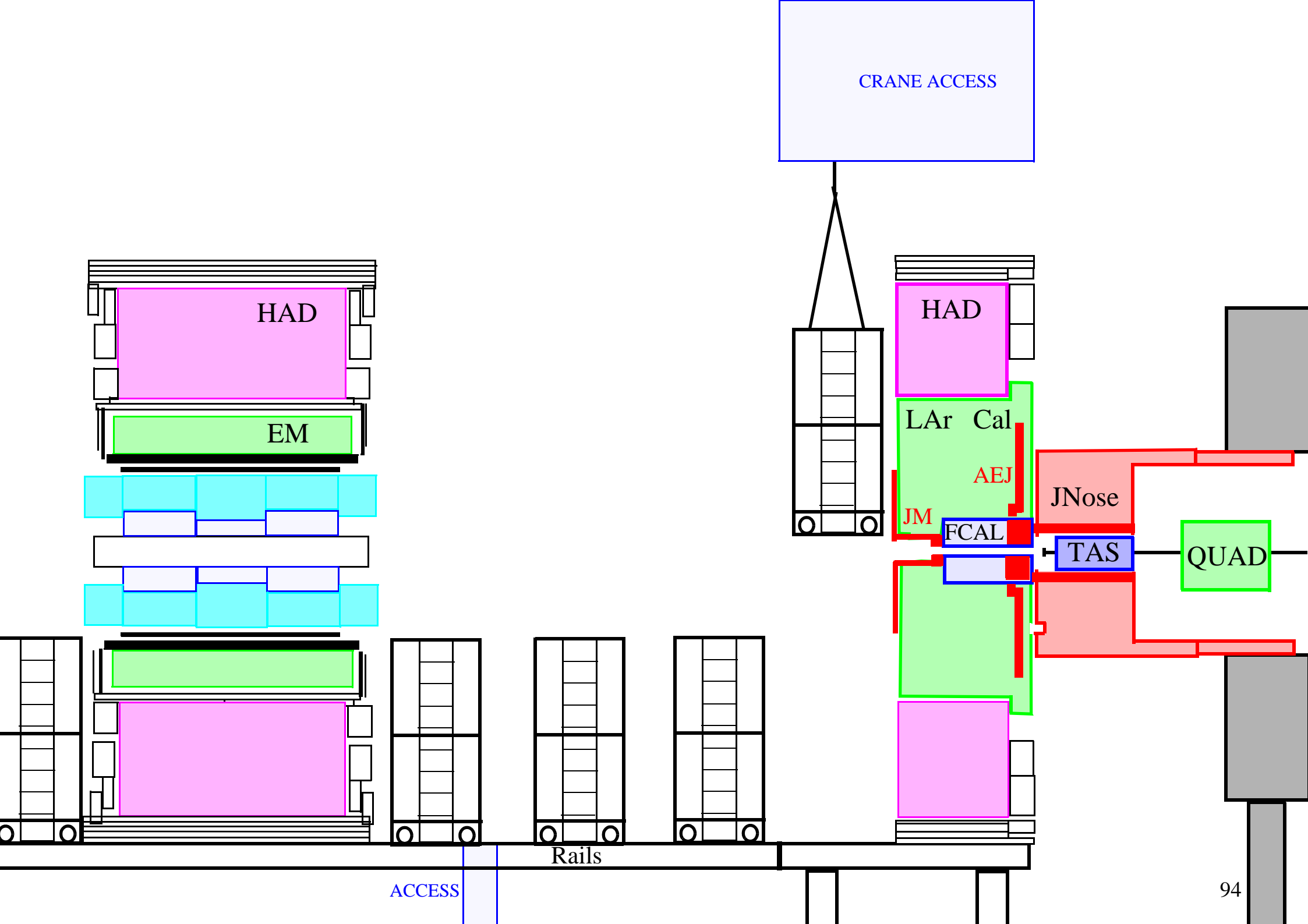

ACCESS

Rails

CRANE ACCESS

HAD

EM

HAD

LAr Cal

AEJ

JM

FCAL

JNose

TAS

QUAD

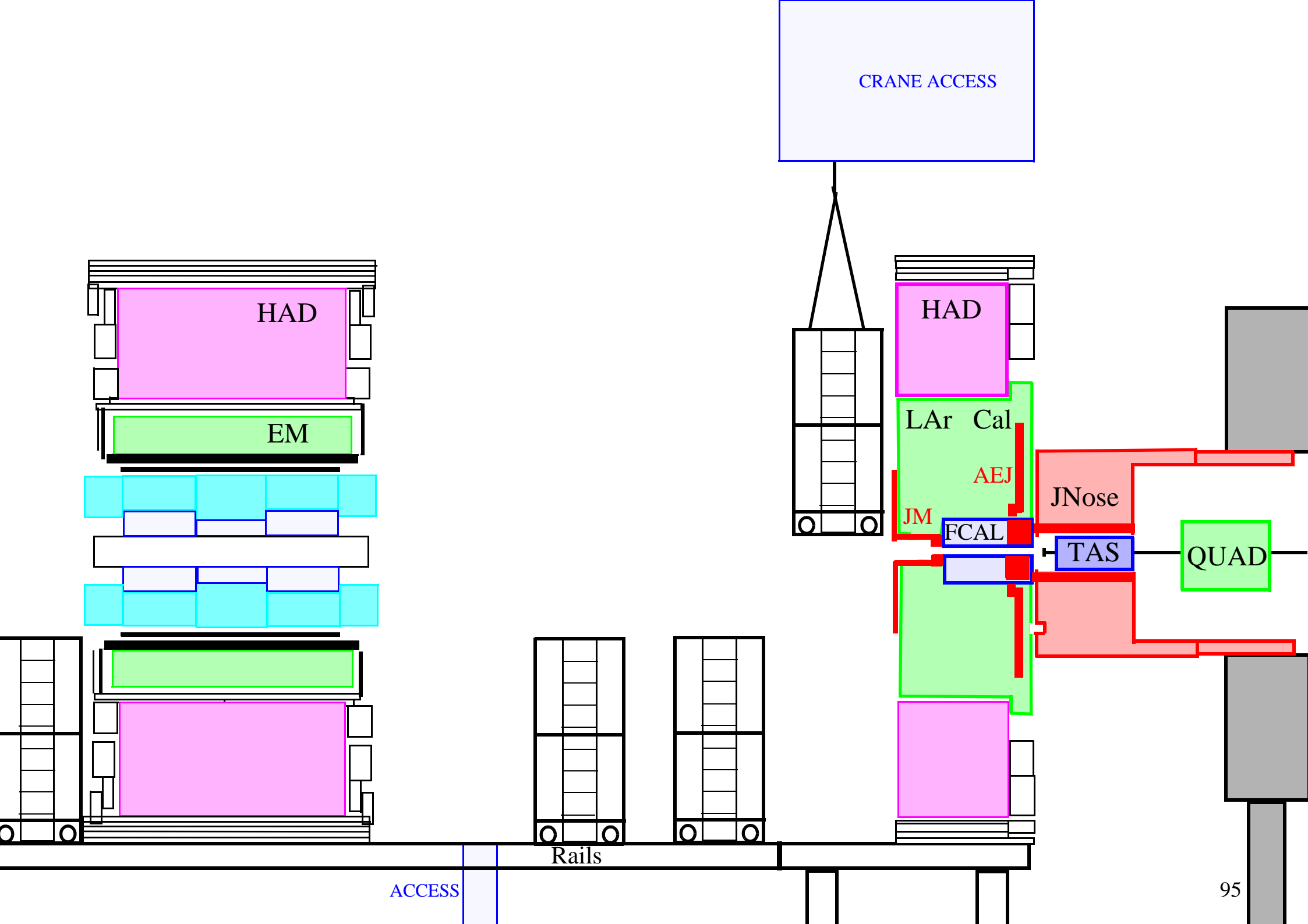

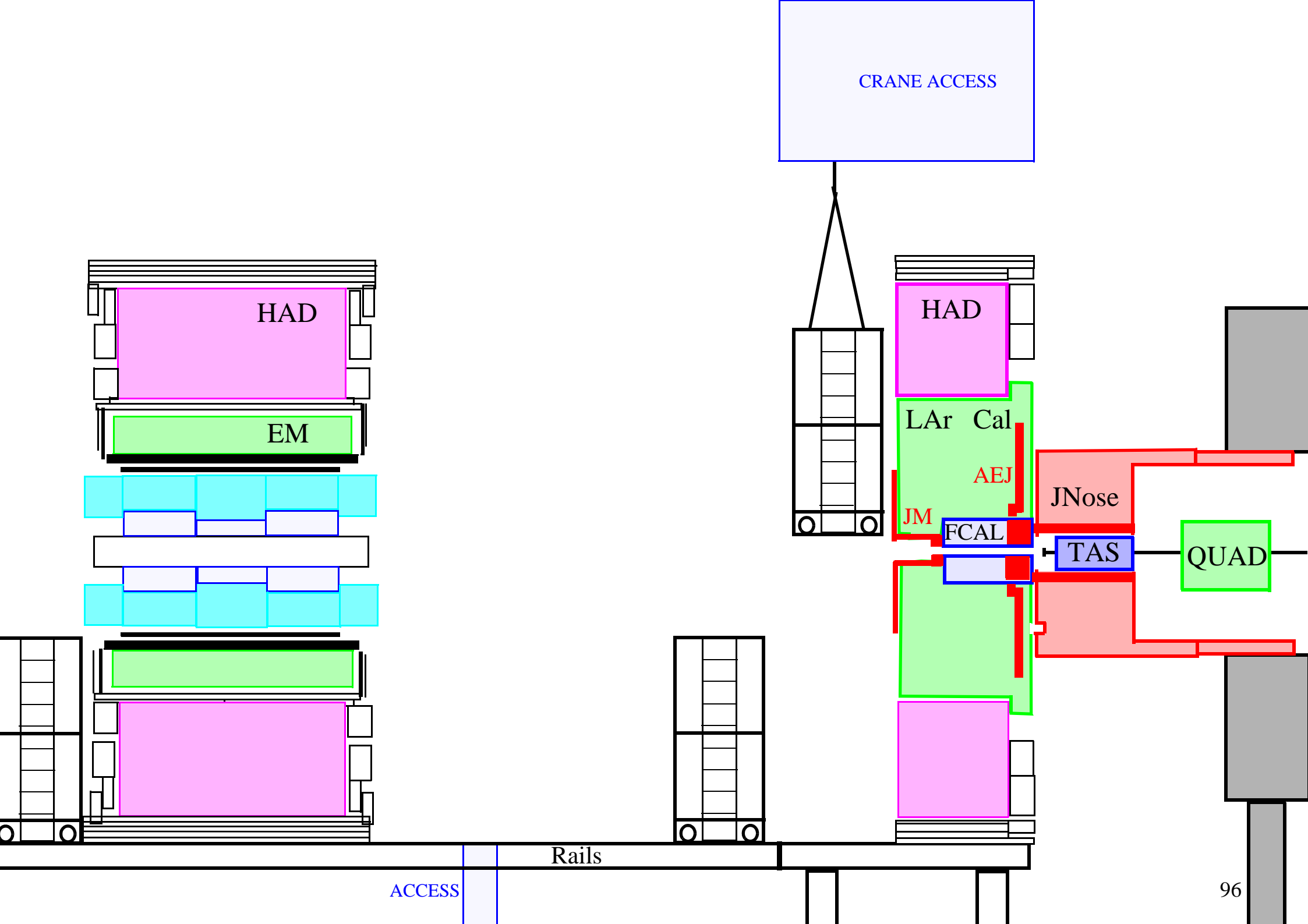

CRANE ACCESS

HAD

EM

HAD

LAr Cal

AEJ

JM

FCAL

JNose

TAS

QUAD

Rails

ACCESS

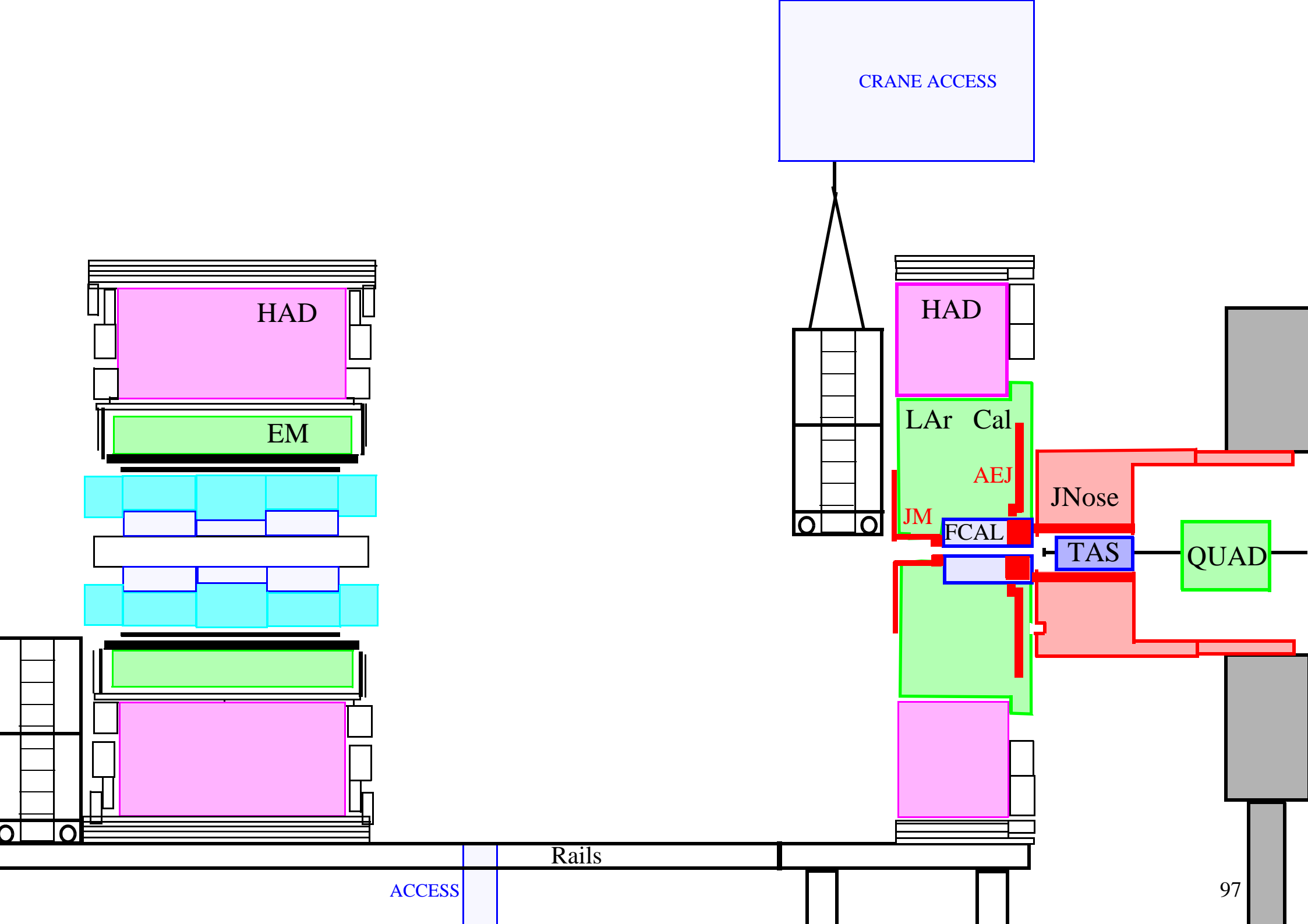

Scaffolding that is max 1.1 m
with access through muon detector.

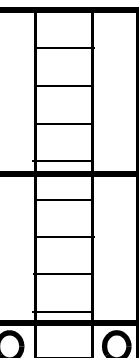
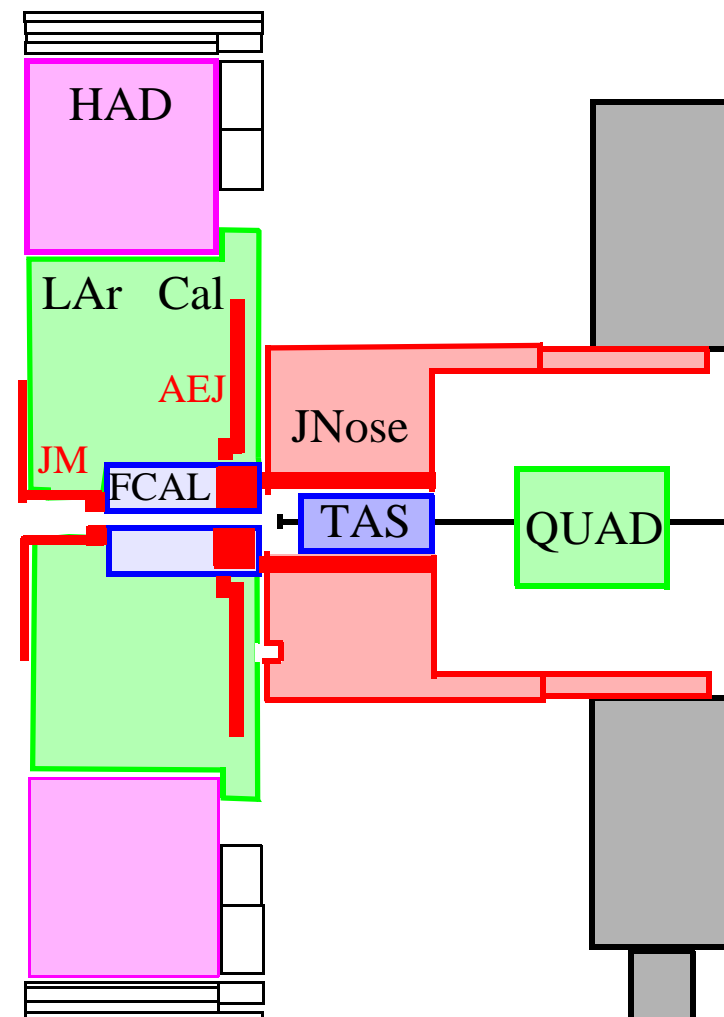
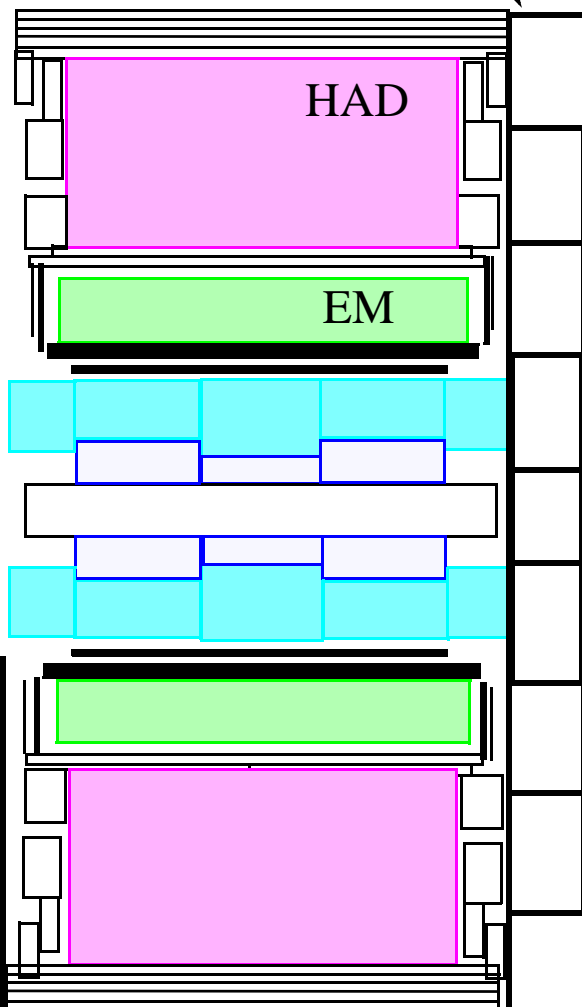
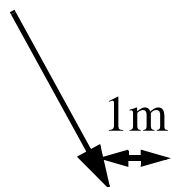

ACCESS

Rails

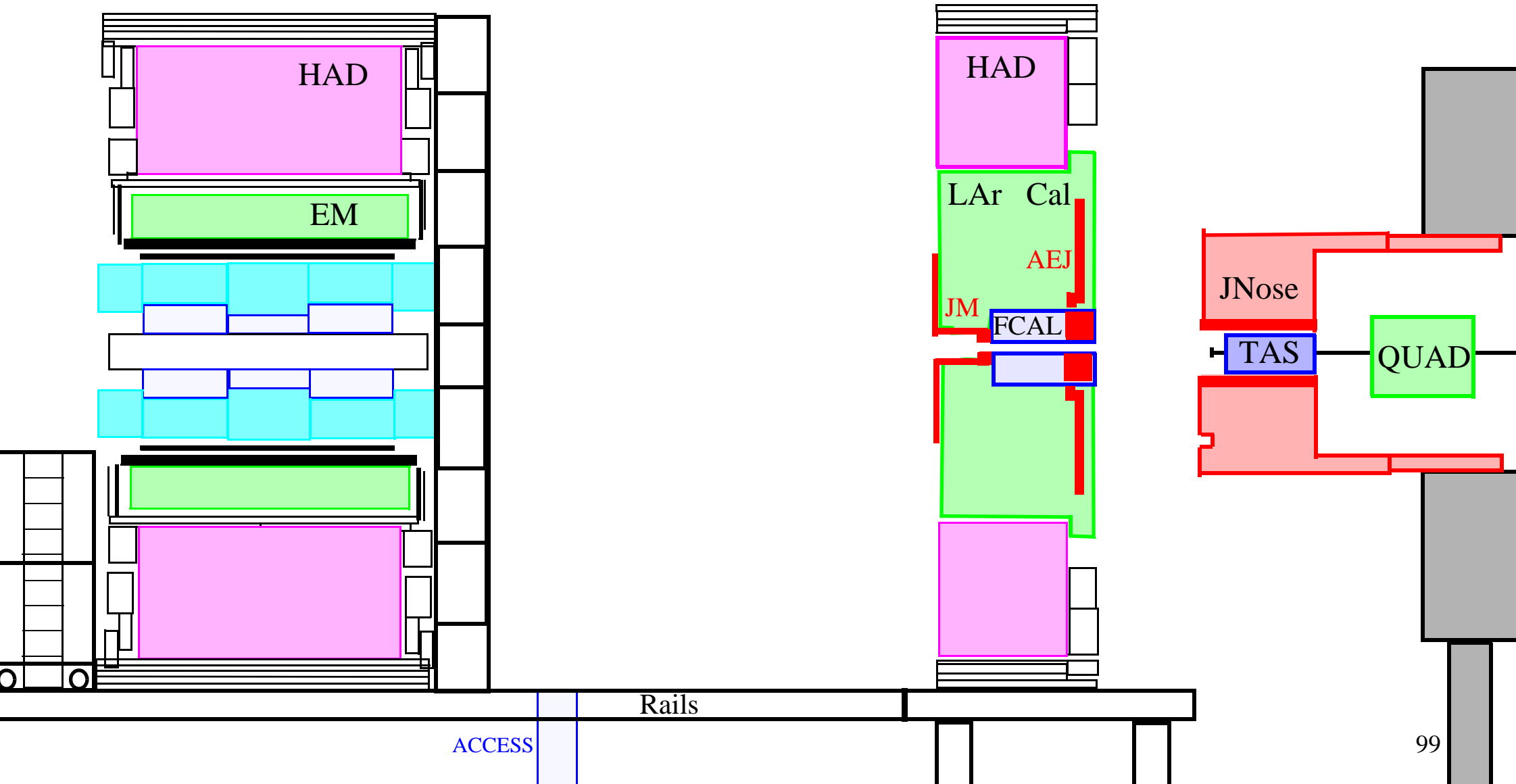



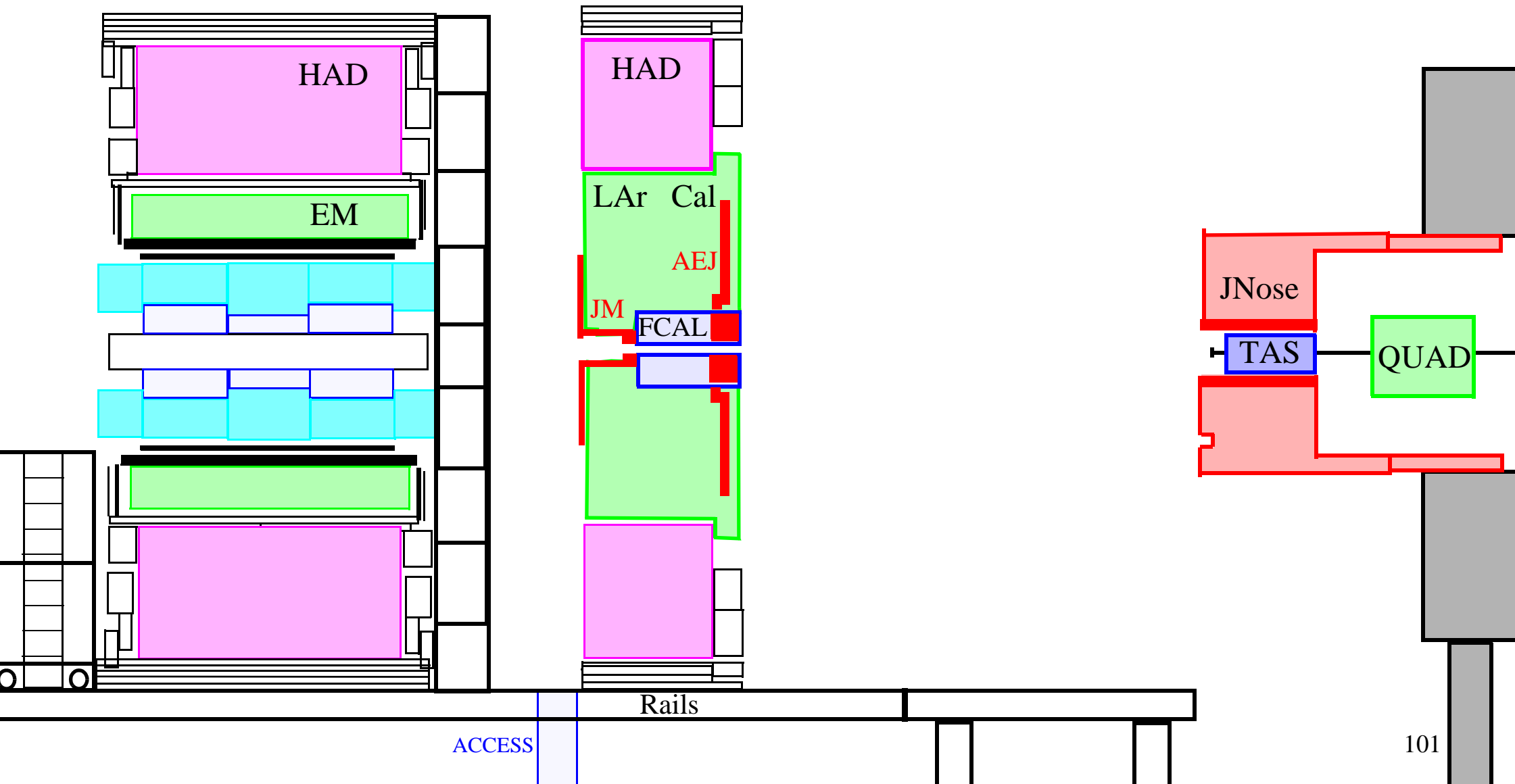

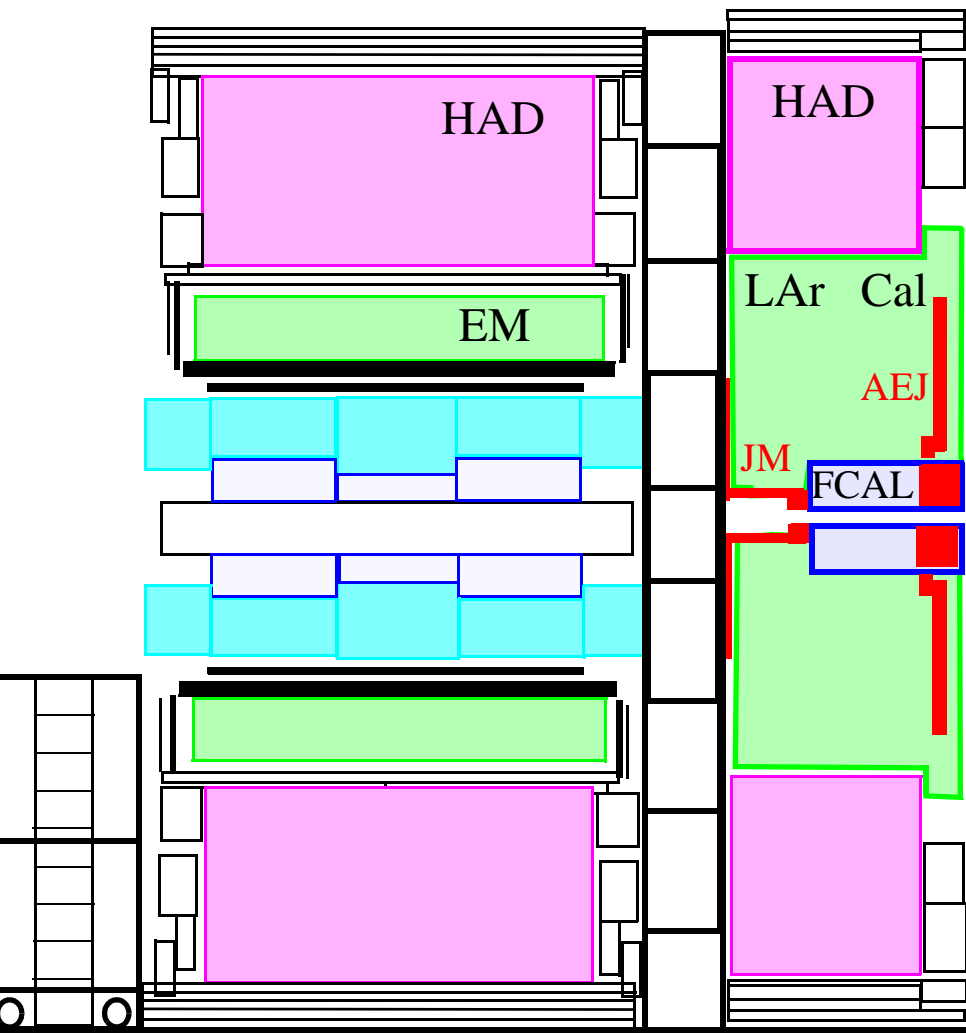

ACCESS

Rails

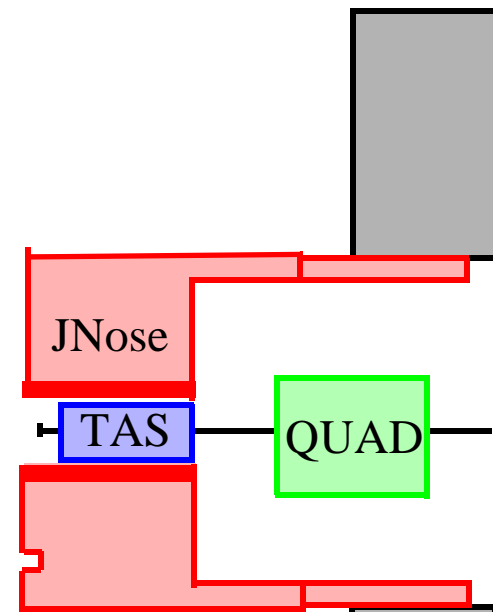

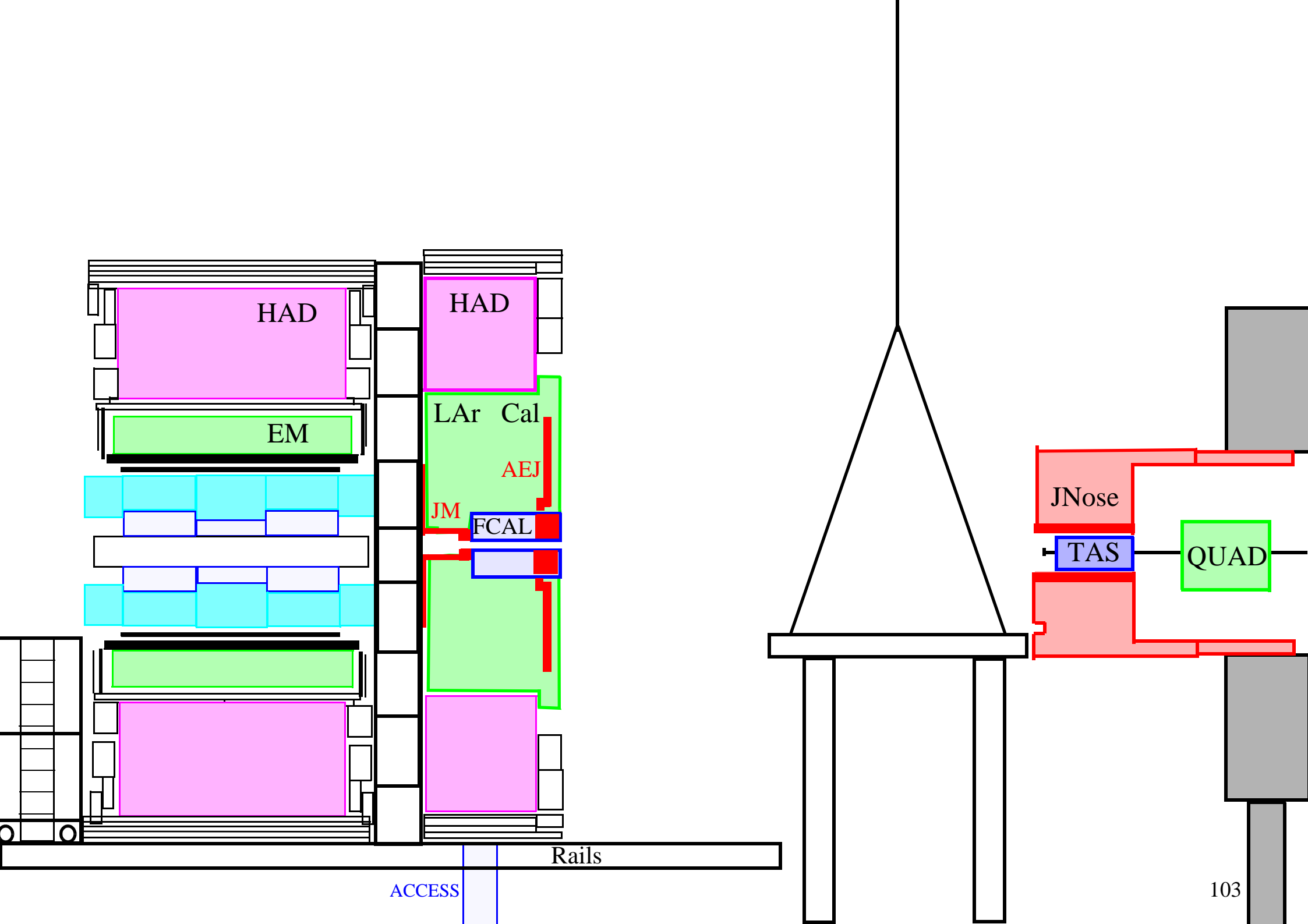

HAD

HAD

EM

LAr Cal

AEJ

JM

FCAL

JNose

TAS

QUAD

Rails

ACCESS

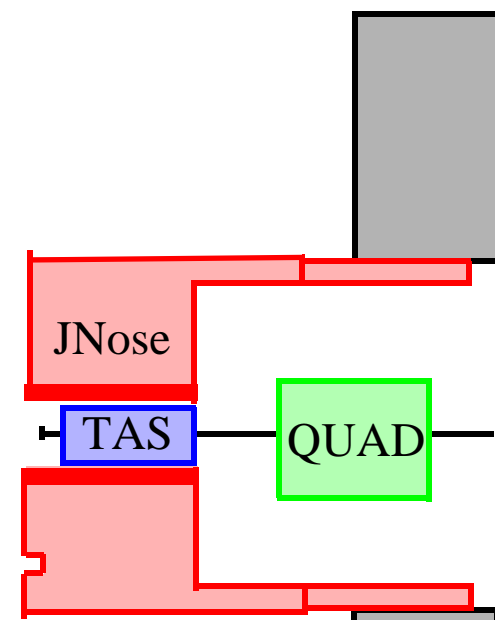
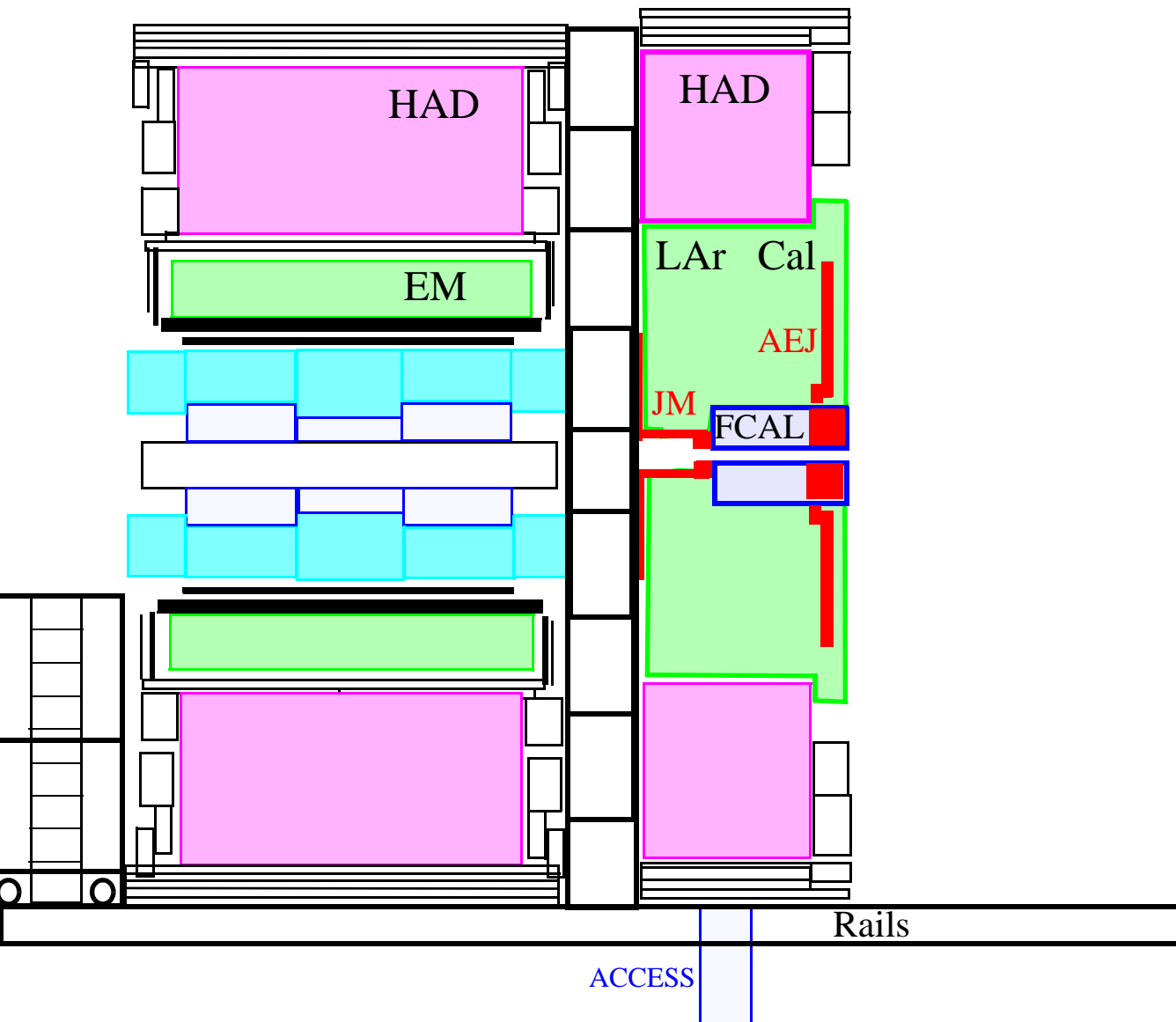

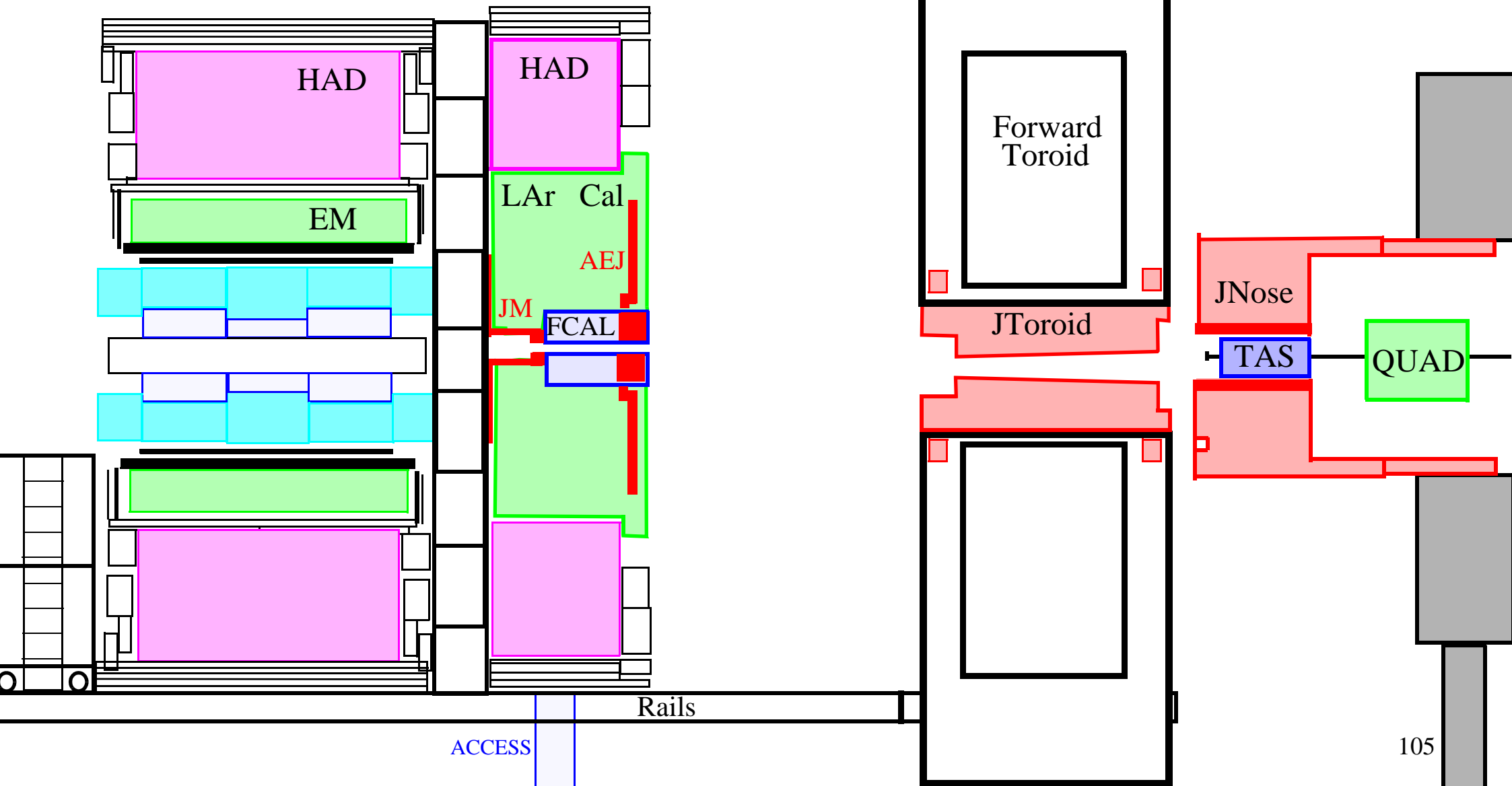

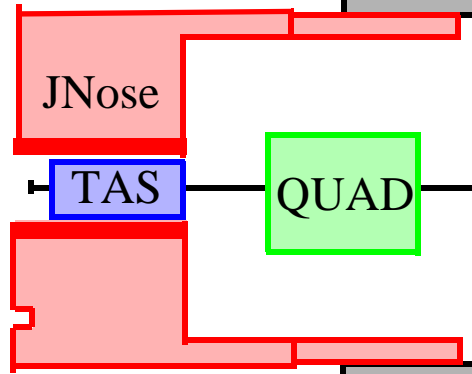
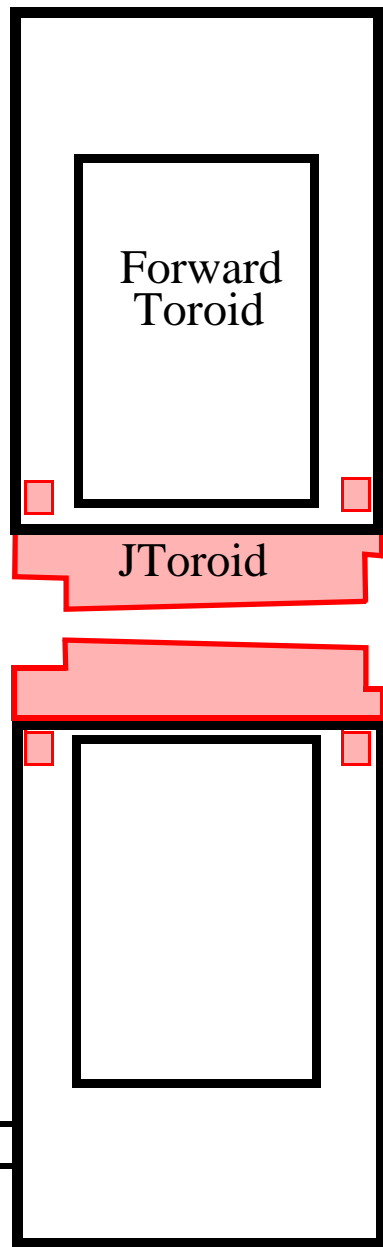
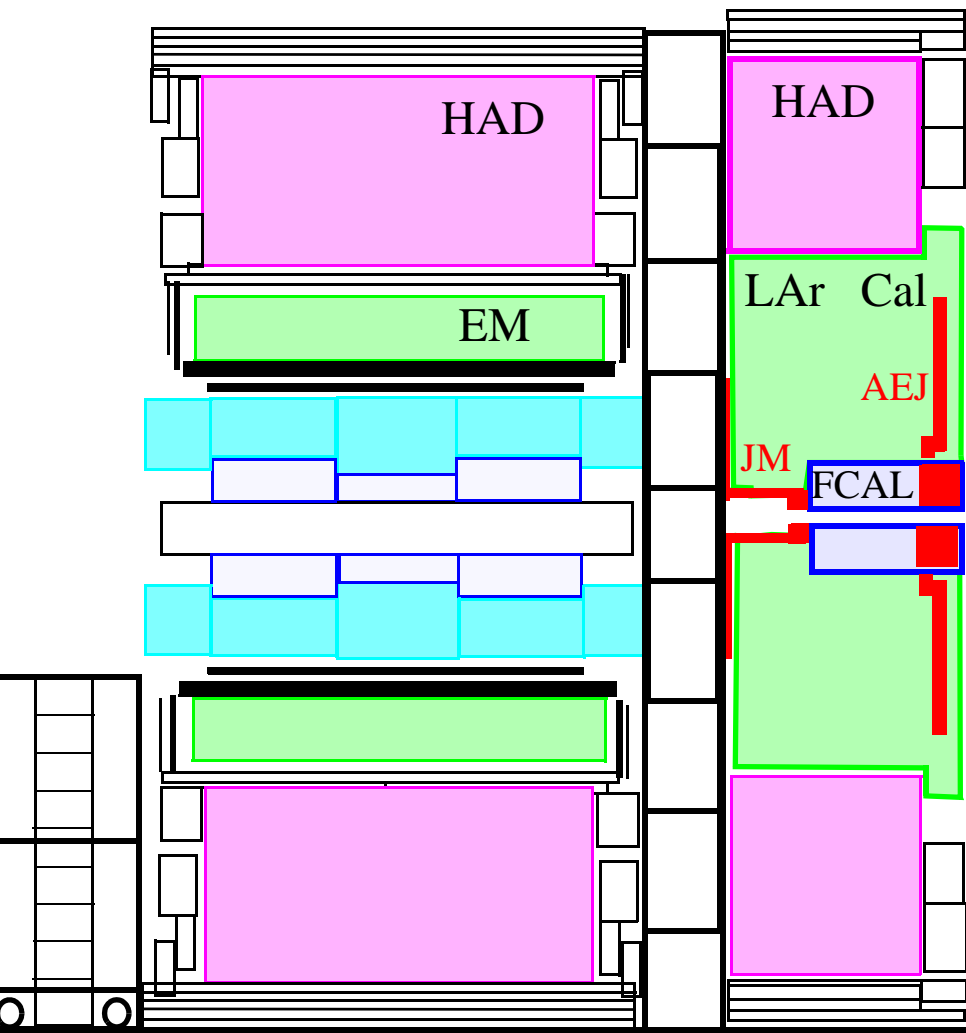

ACCESS
Rails

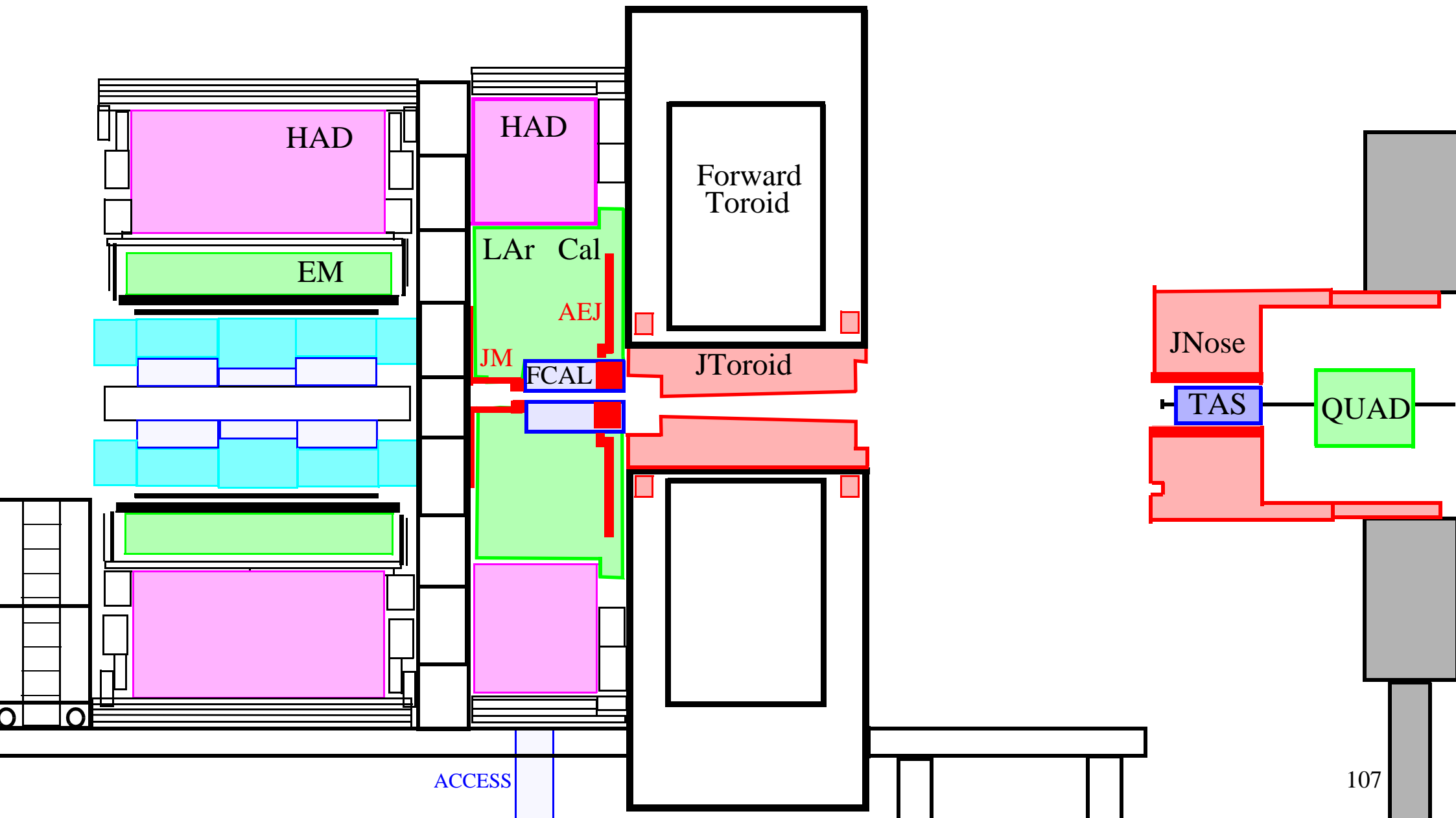

ACCESS

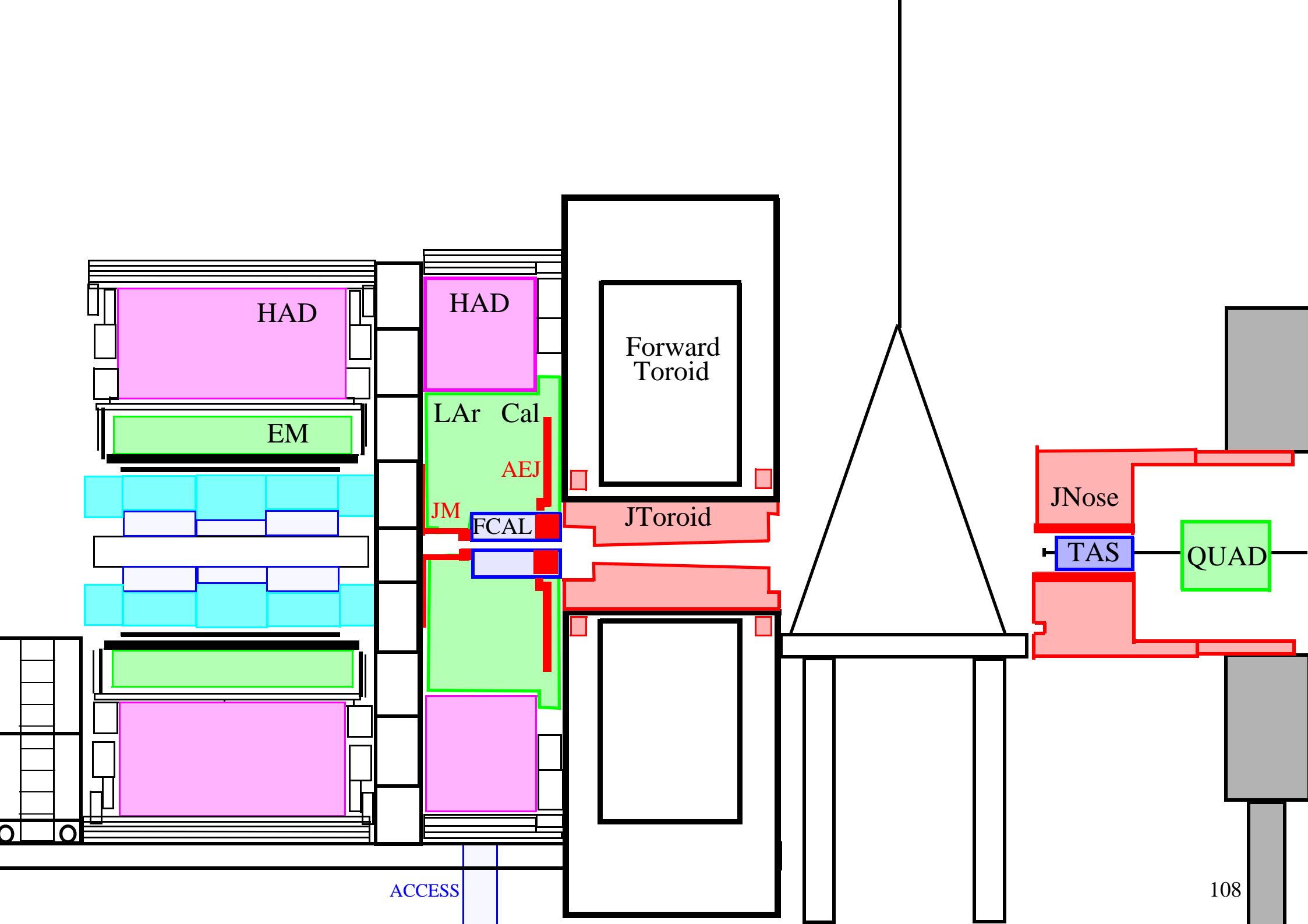

ACCESS

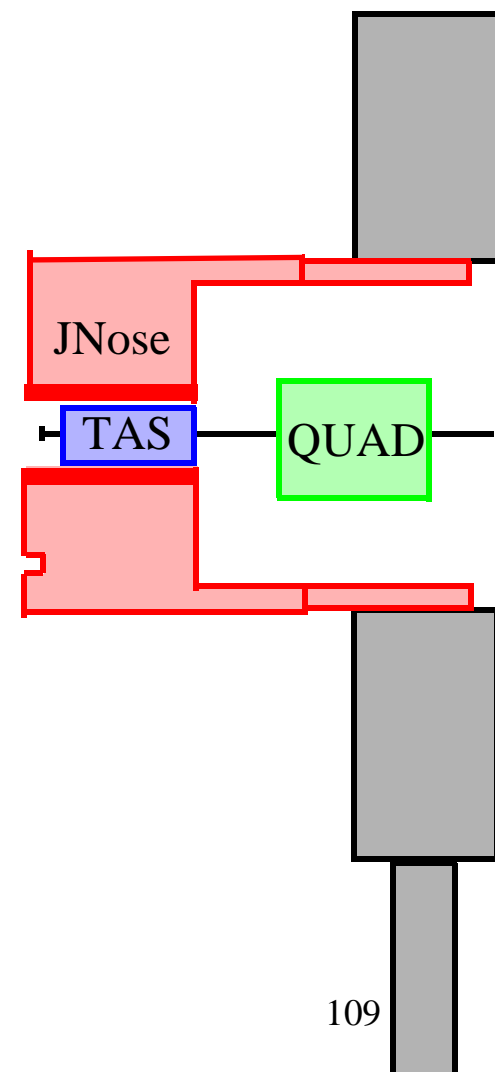
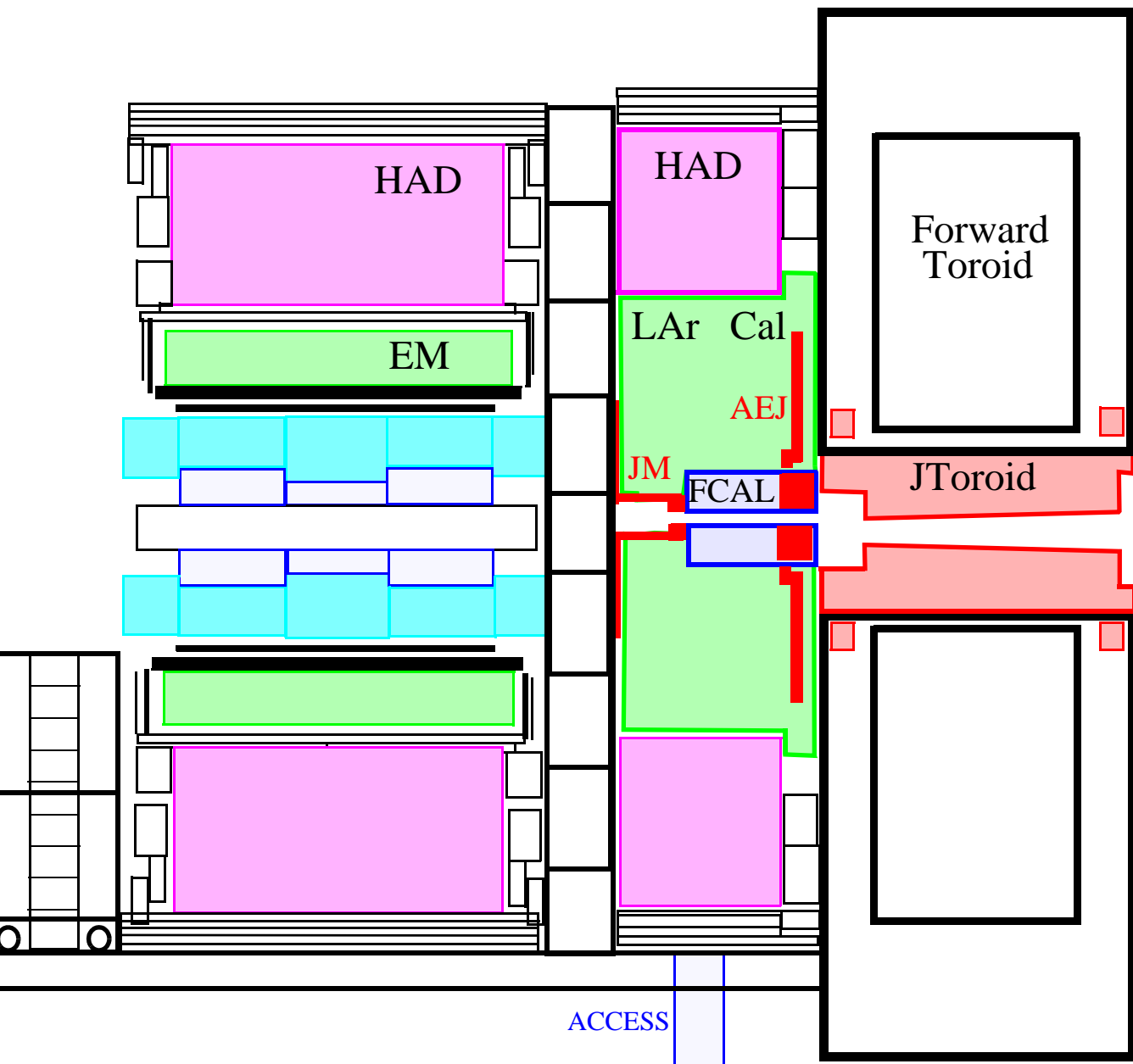

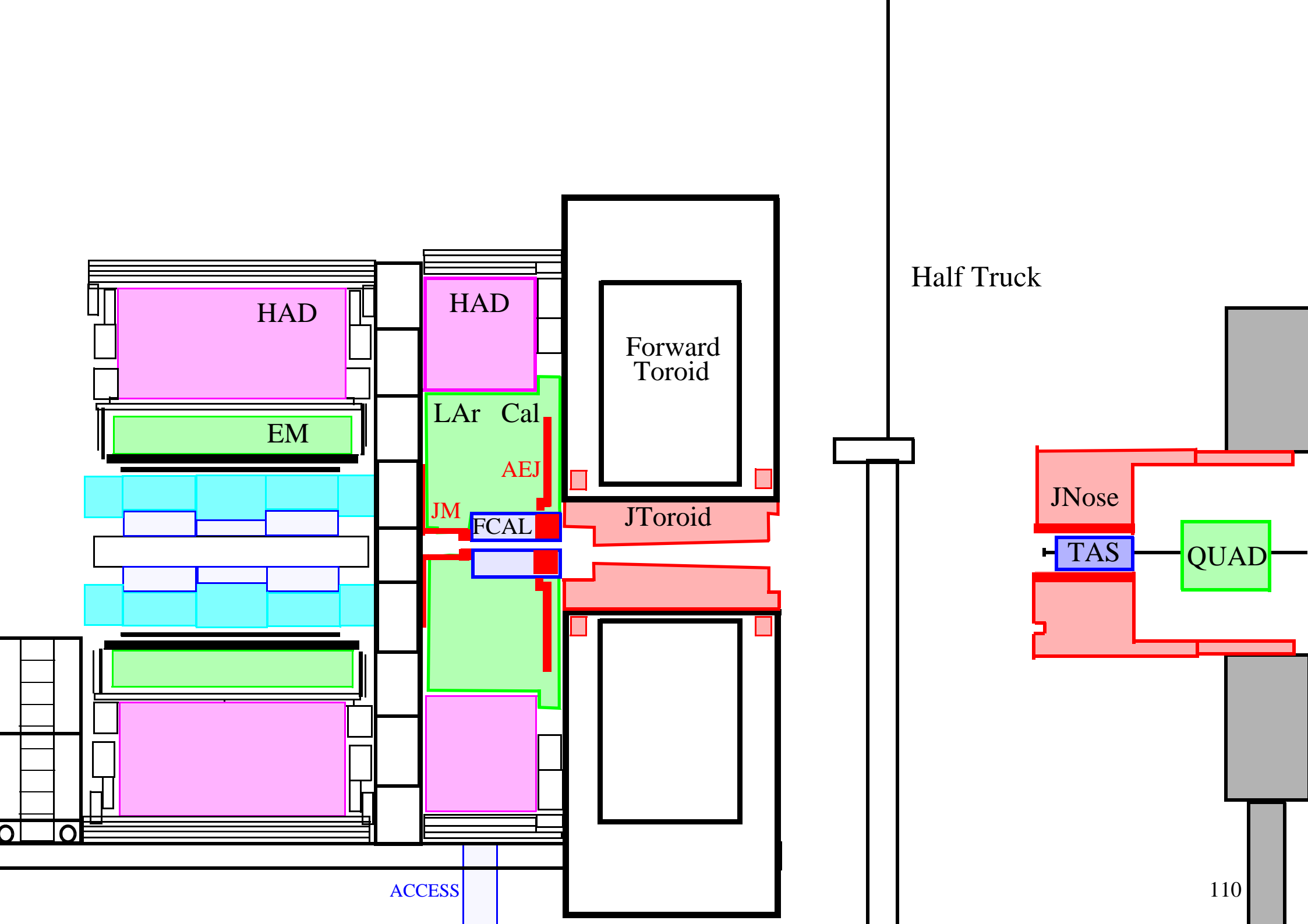

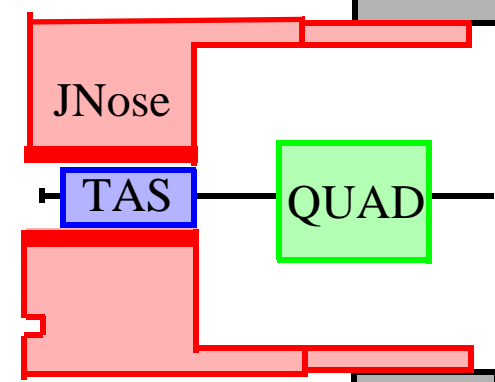
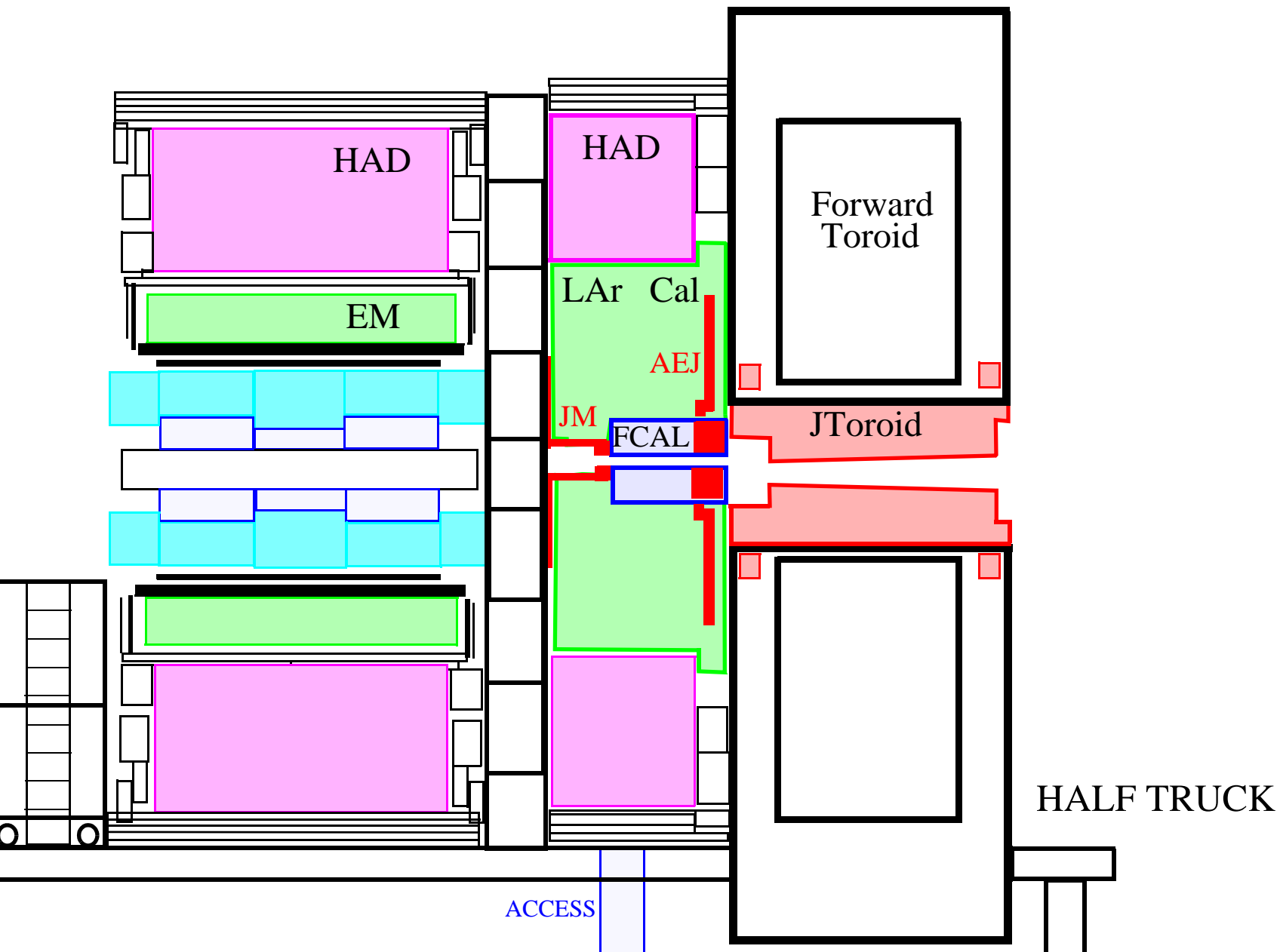

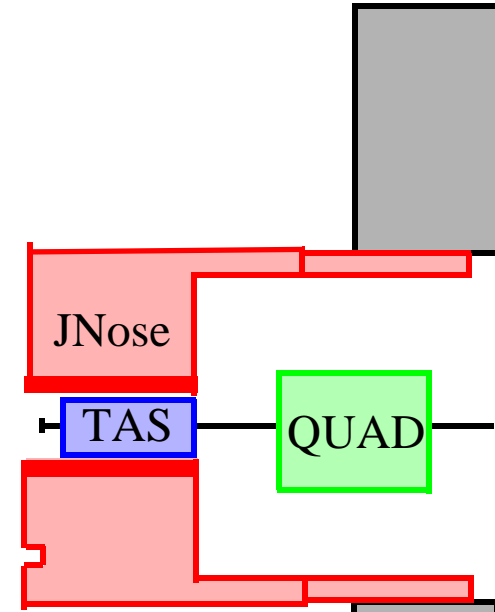
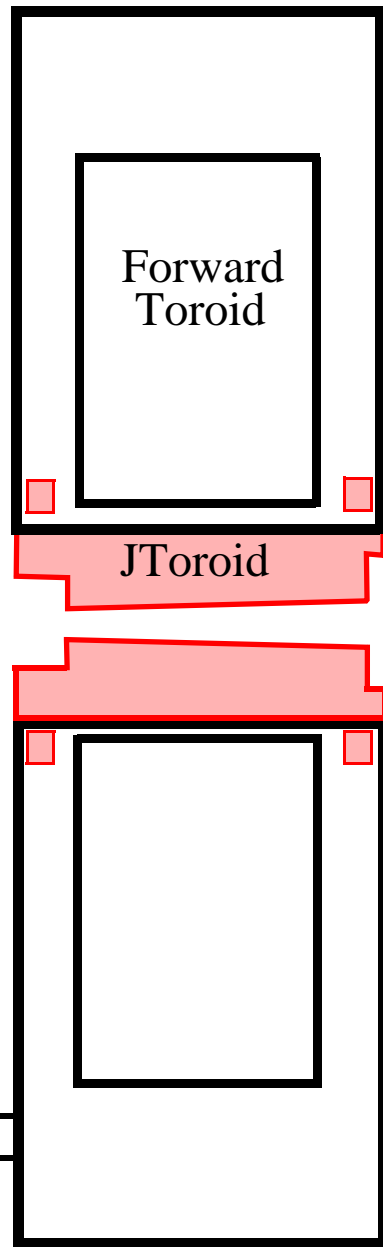
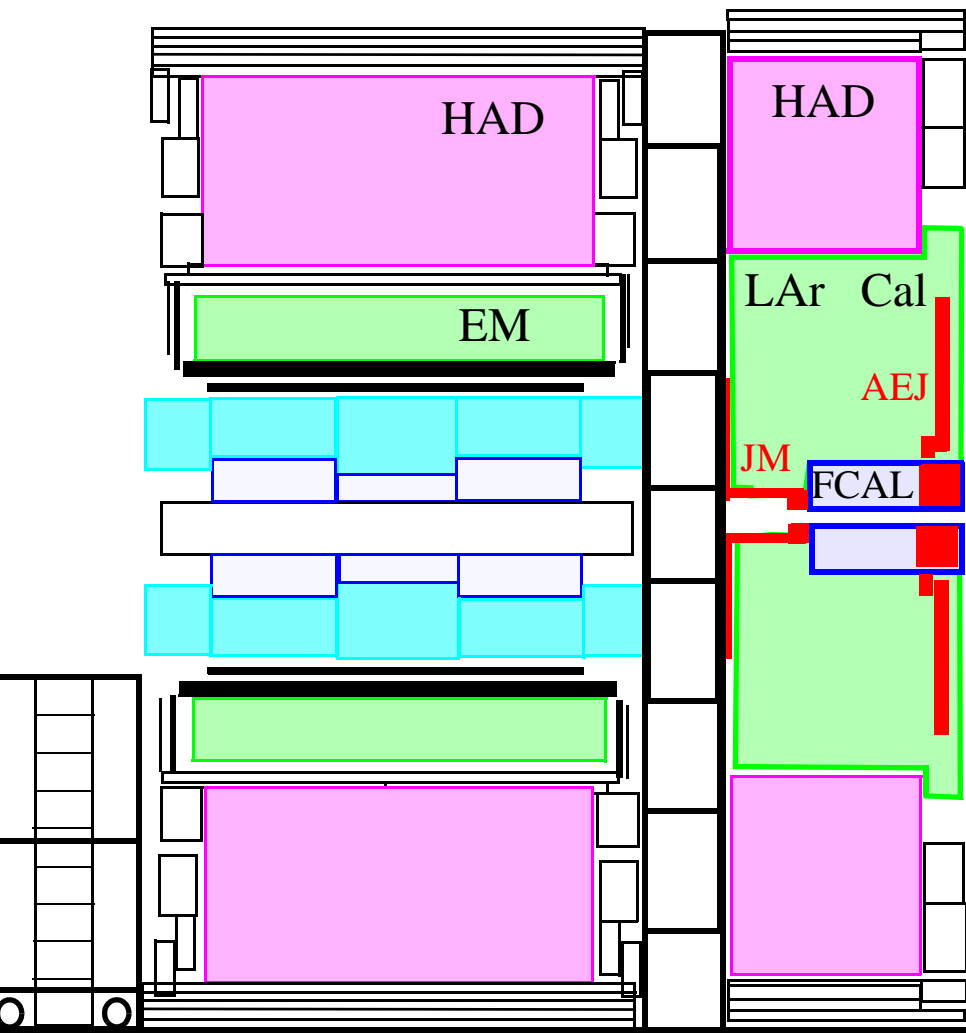

ACCESS

Scaffolding that is max 1.7 m
with access through muon detector.

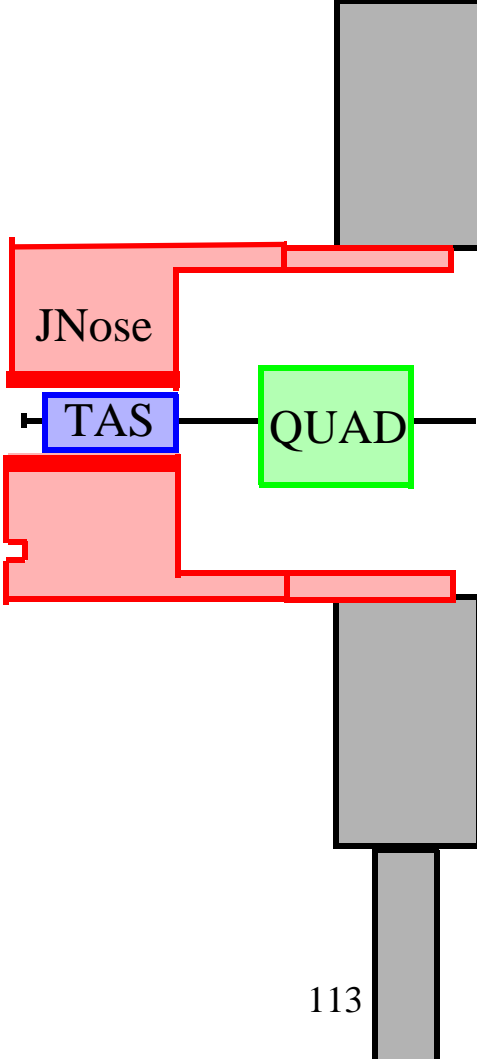
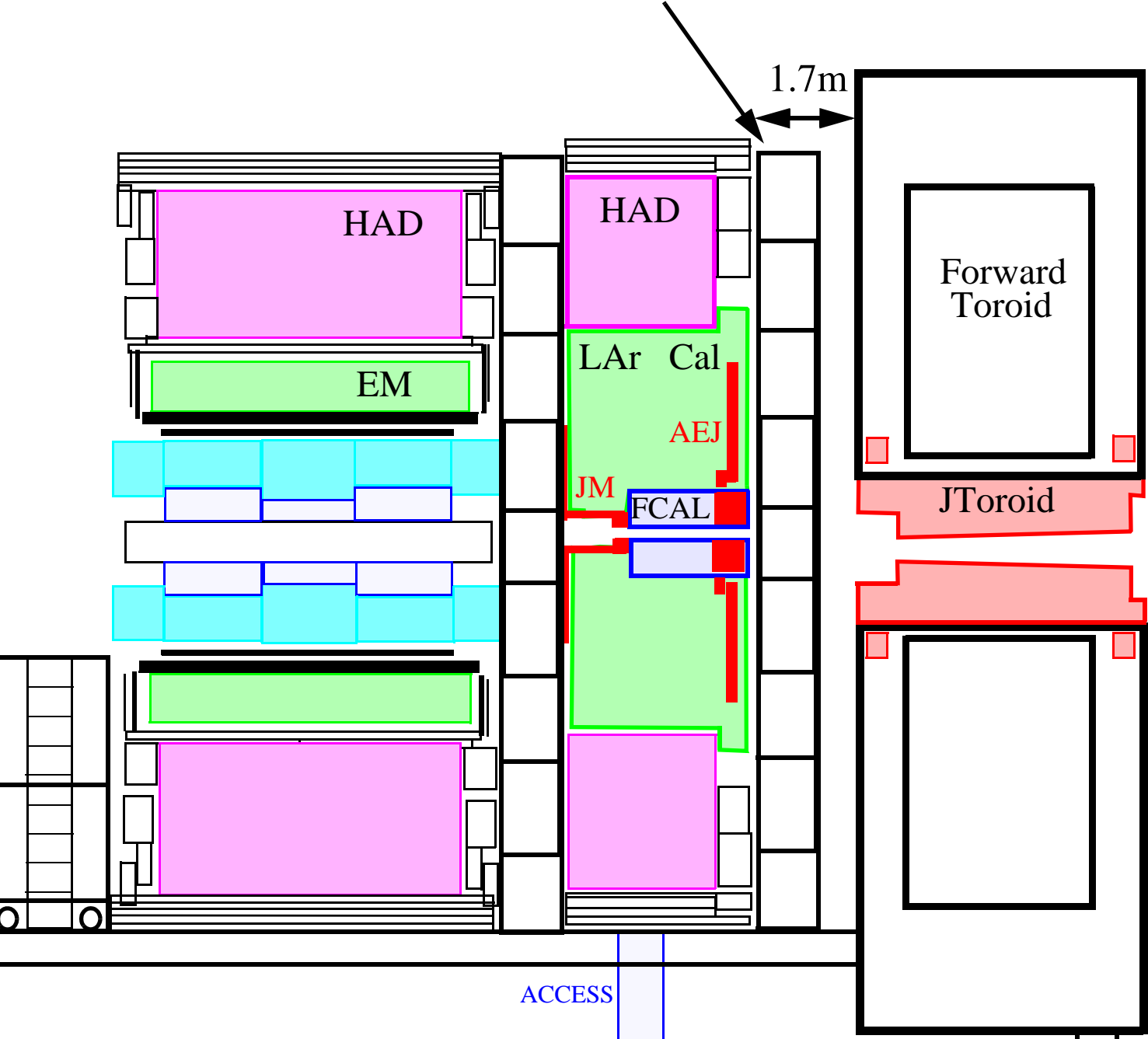

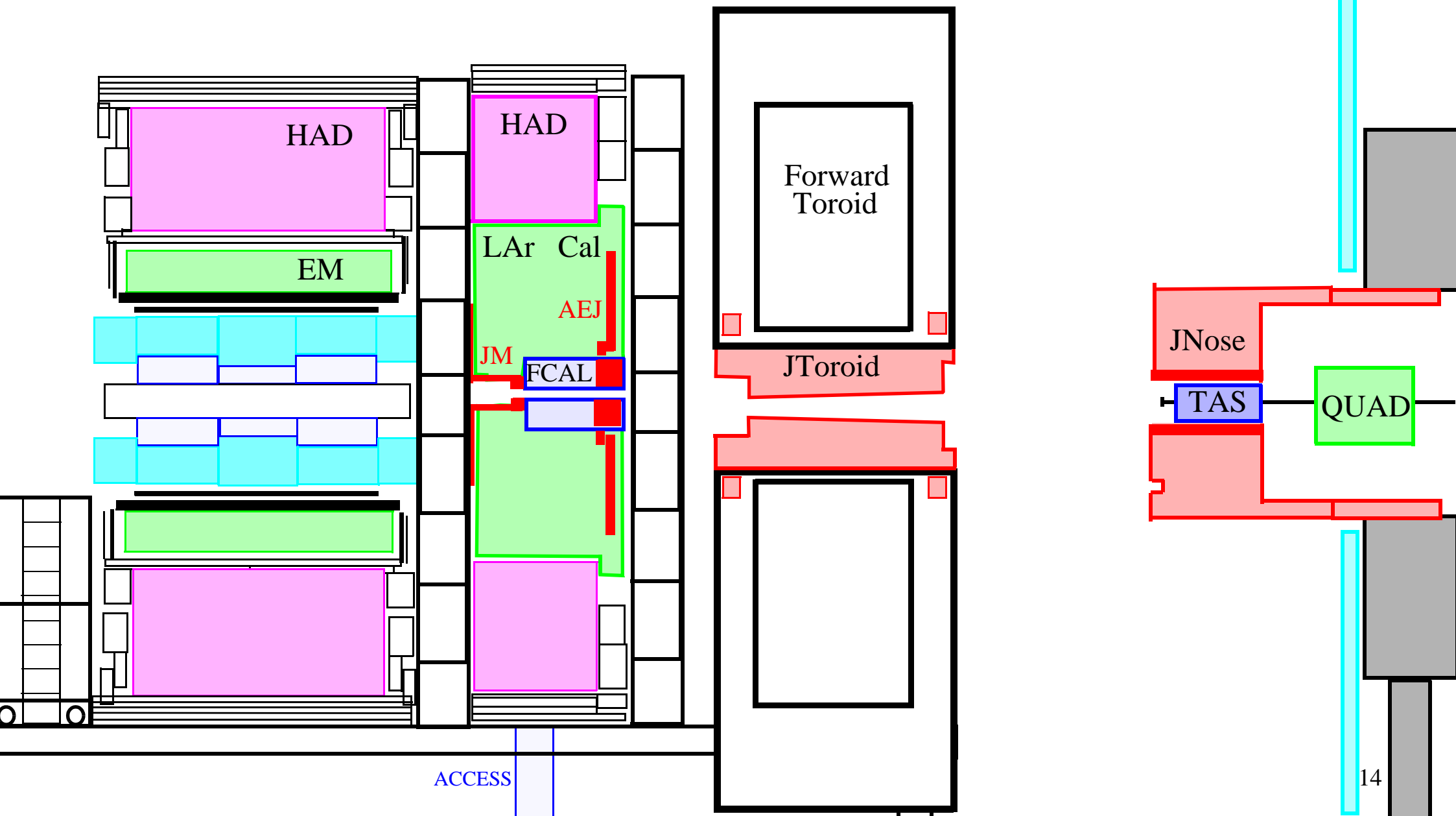

ACCESS

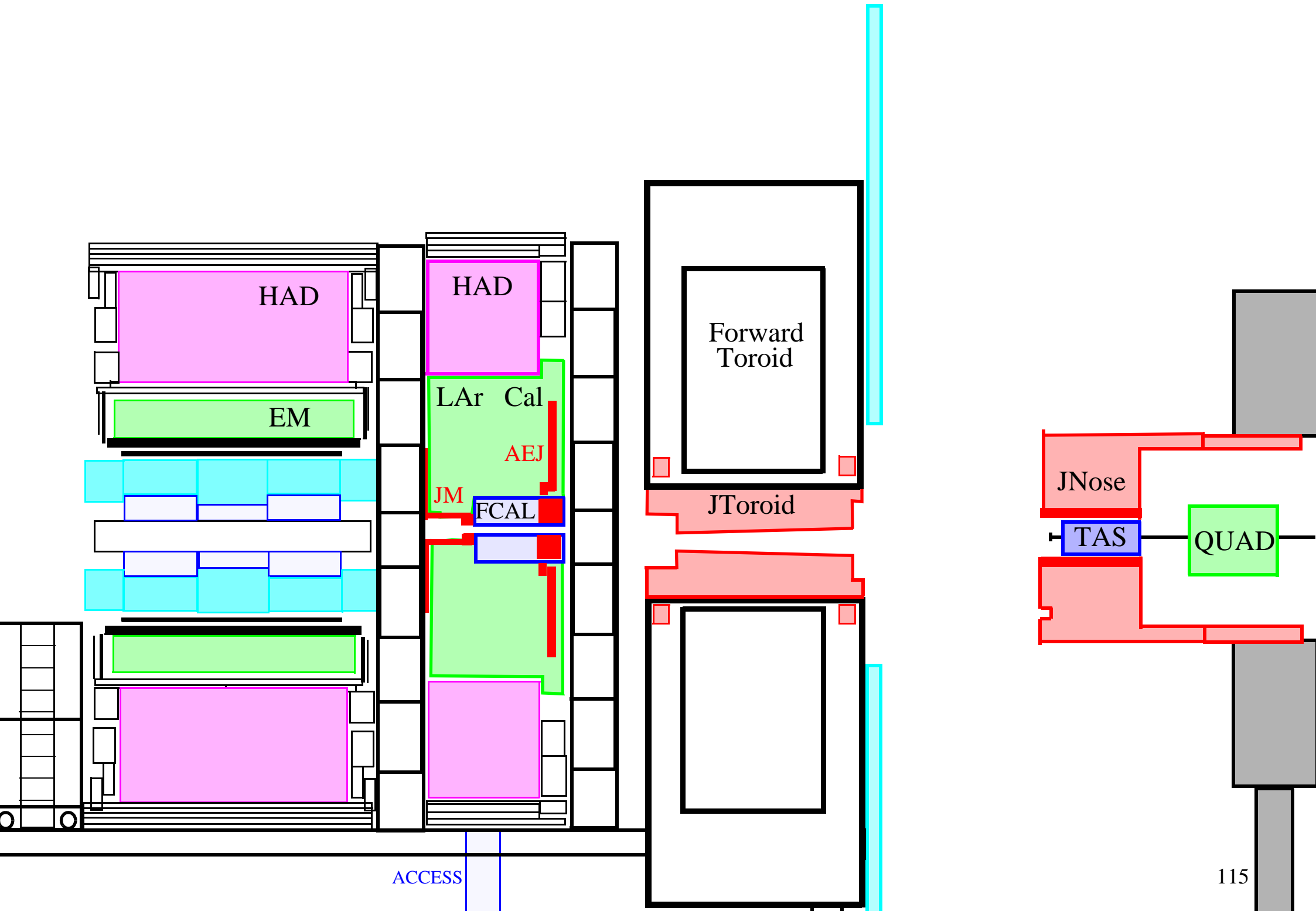

January 2007

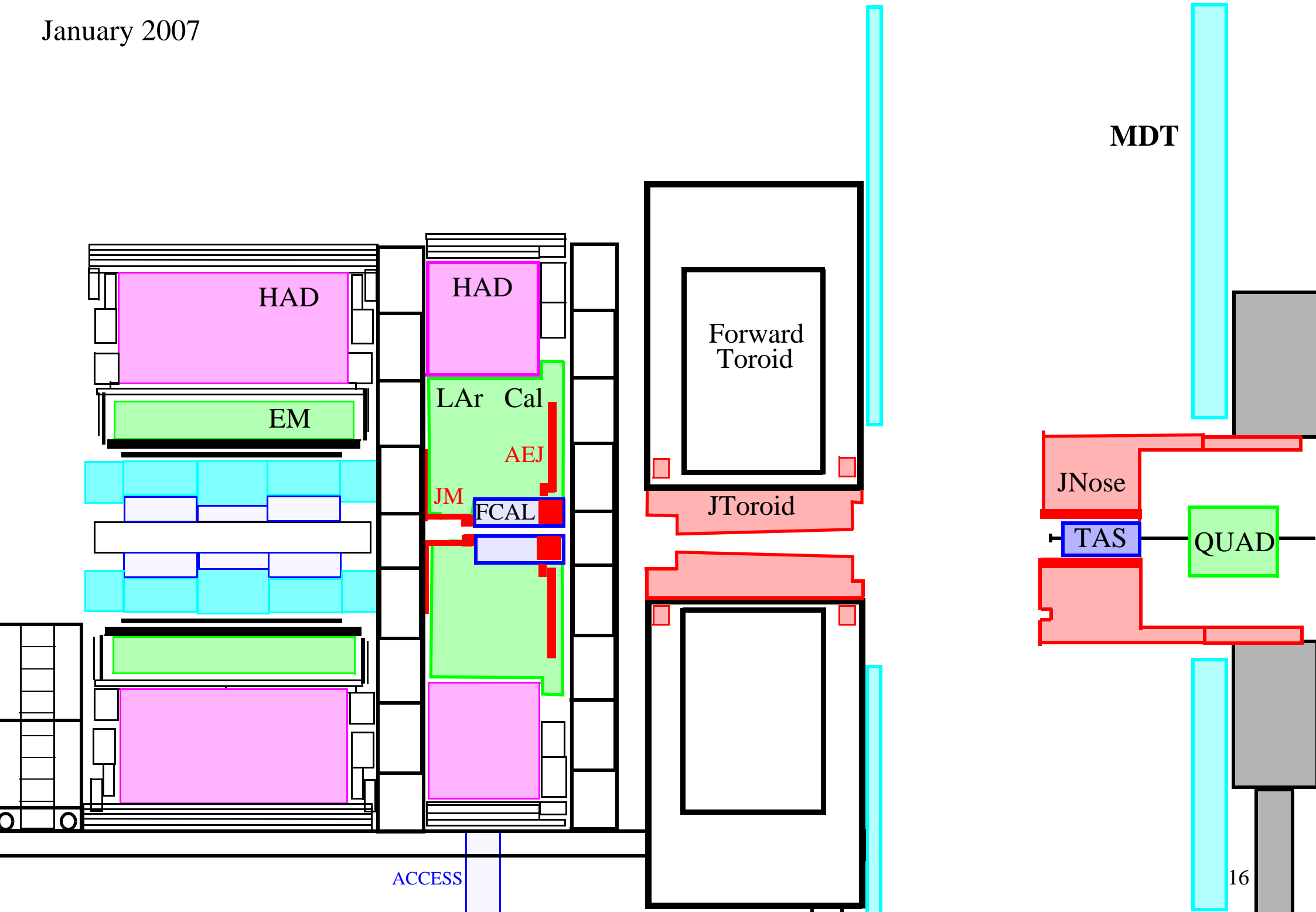

When is the Big Wheel electronic racks and gangways installed ?

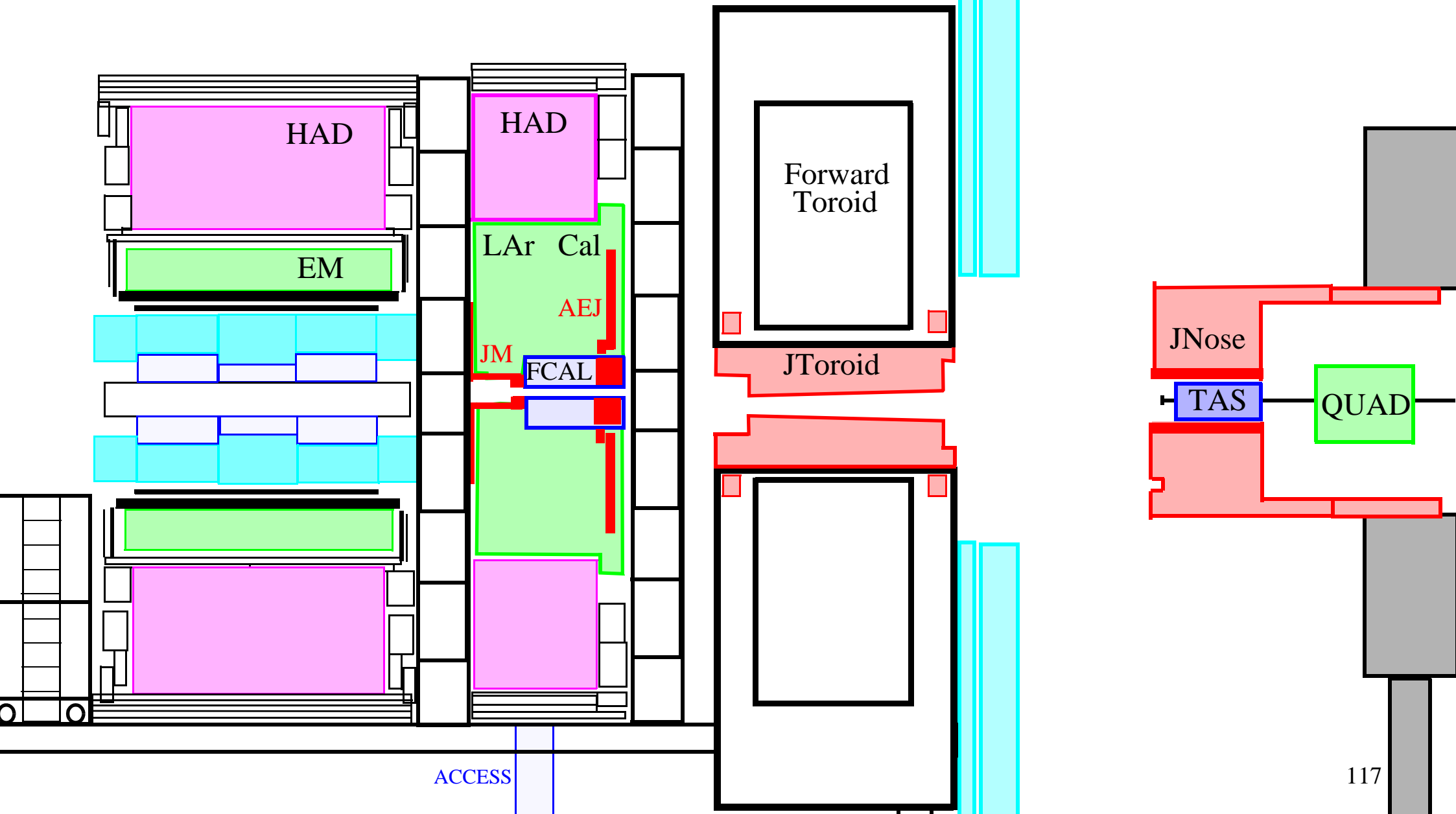

Is this scaffolding sufficient during PIXEL installation ?

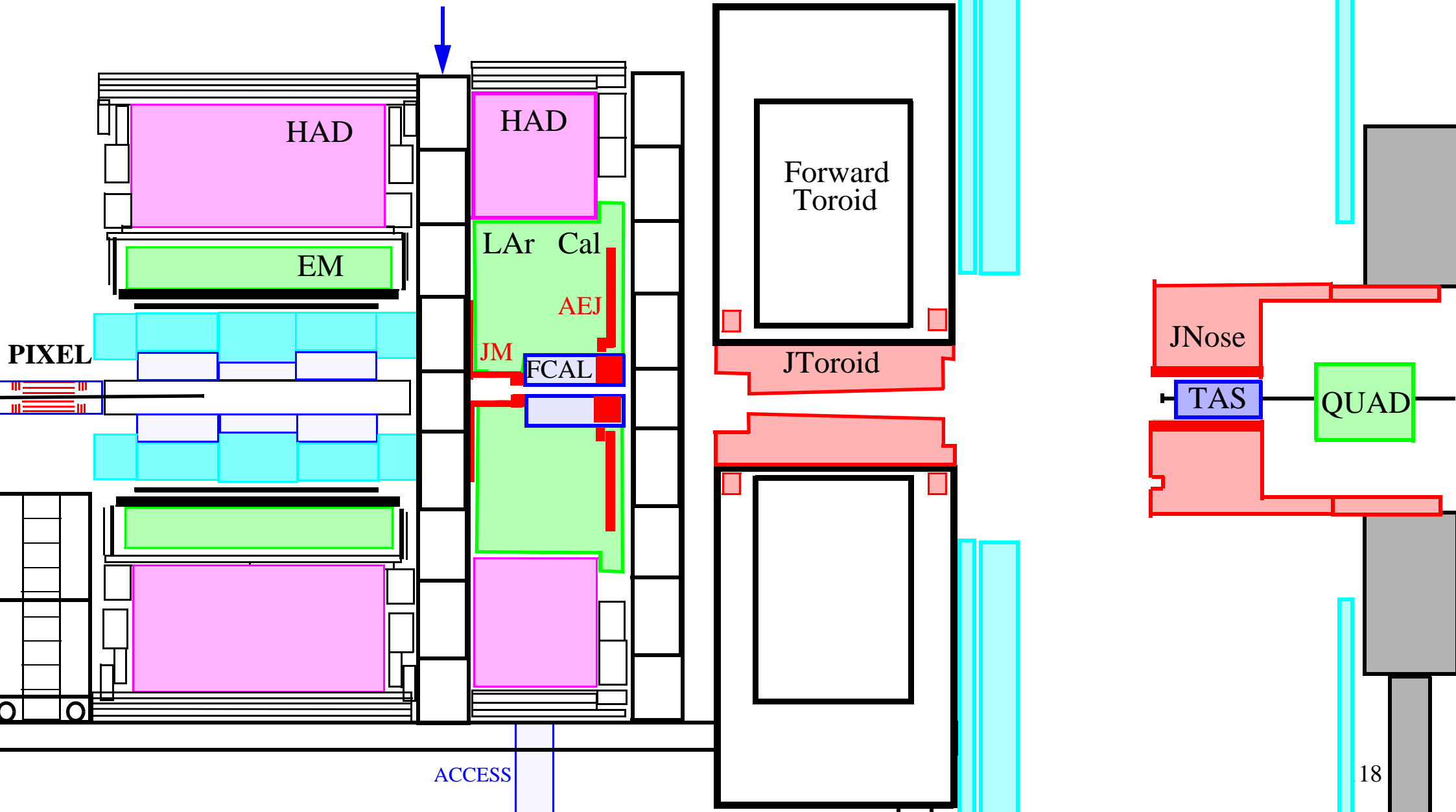

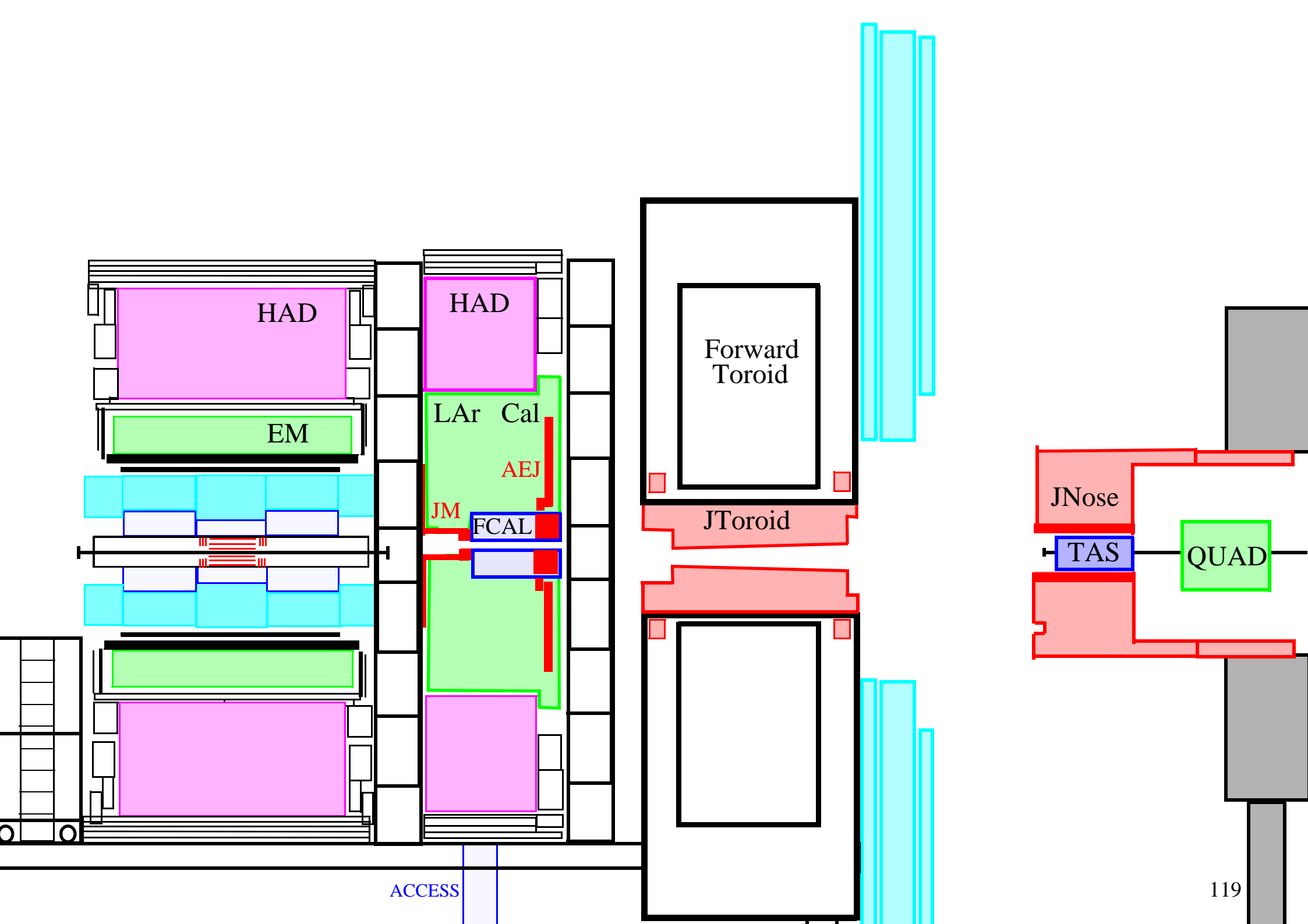

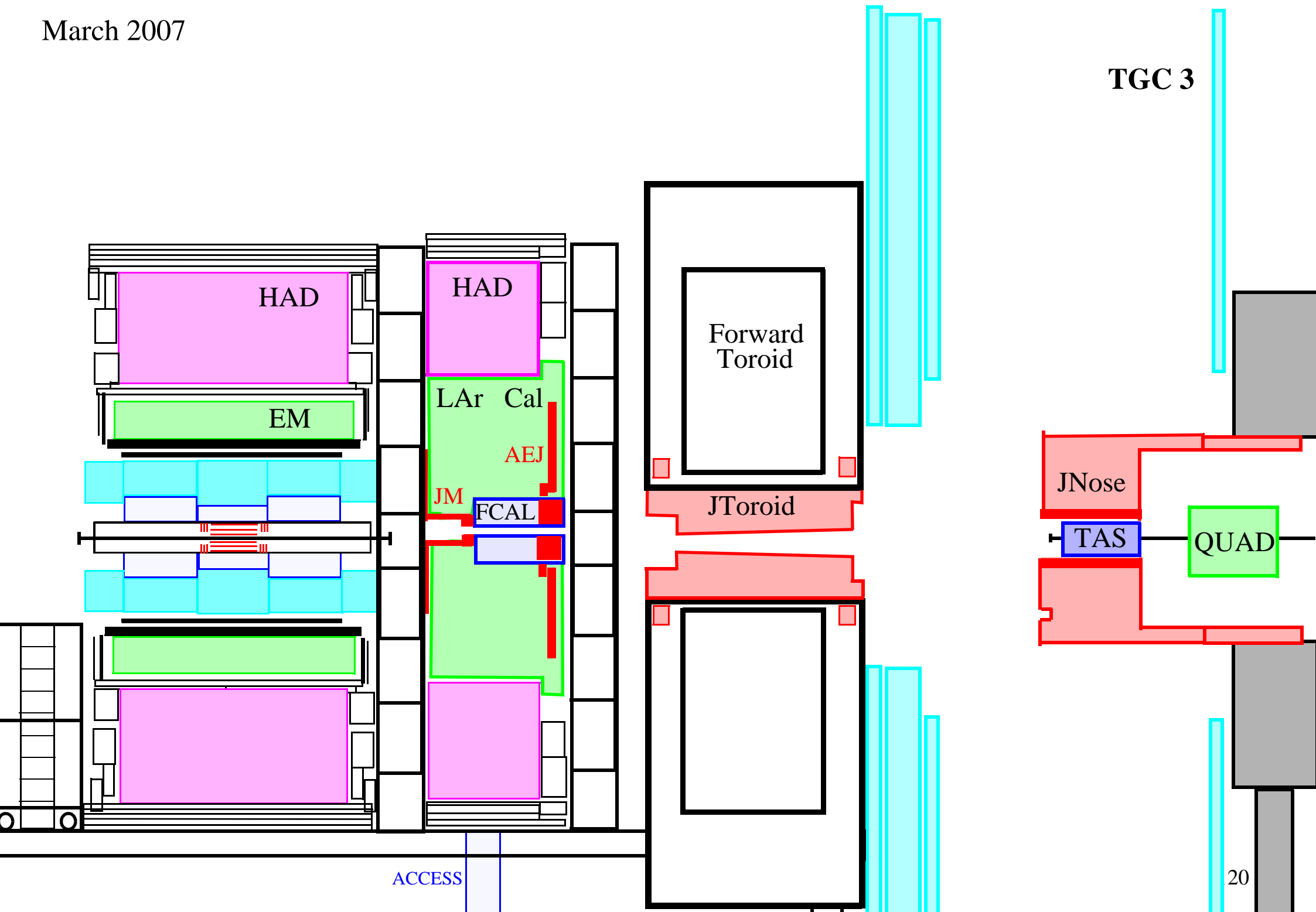

ACCESS

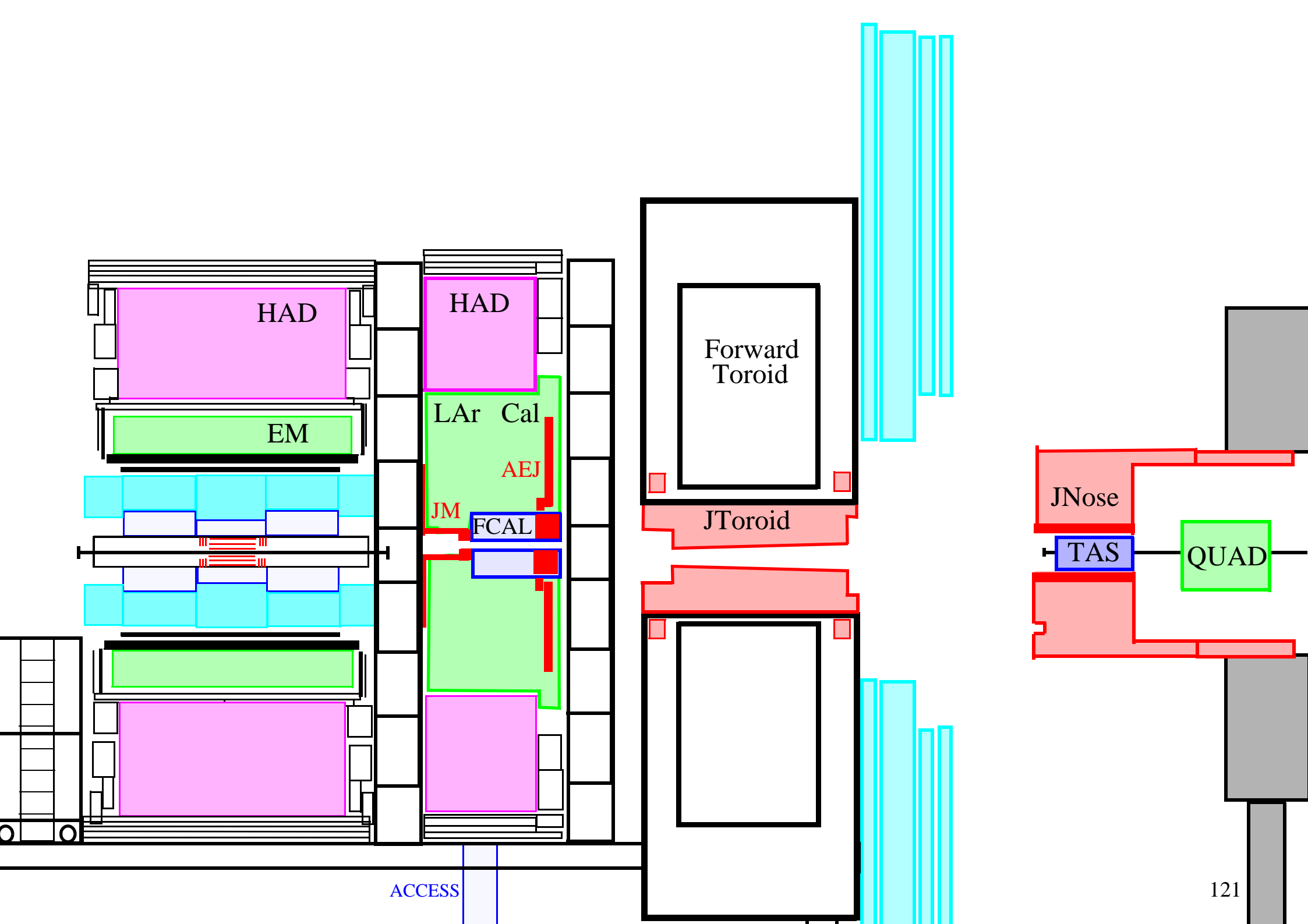

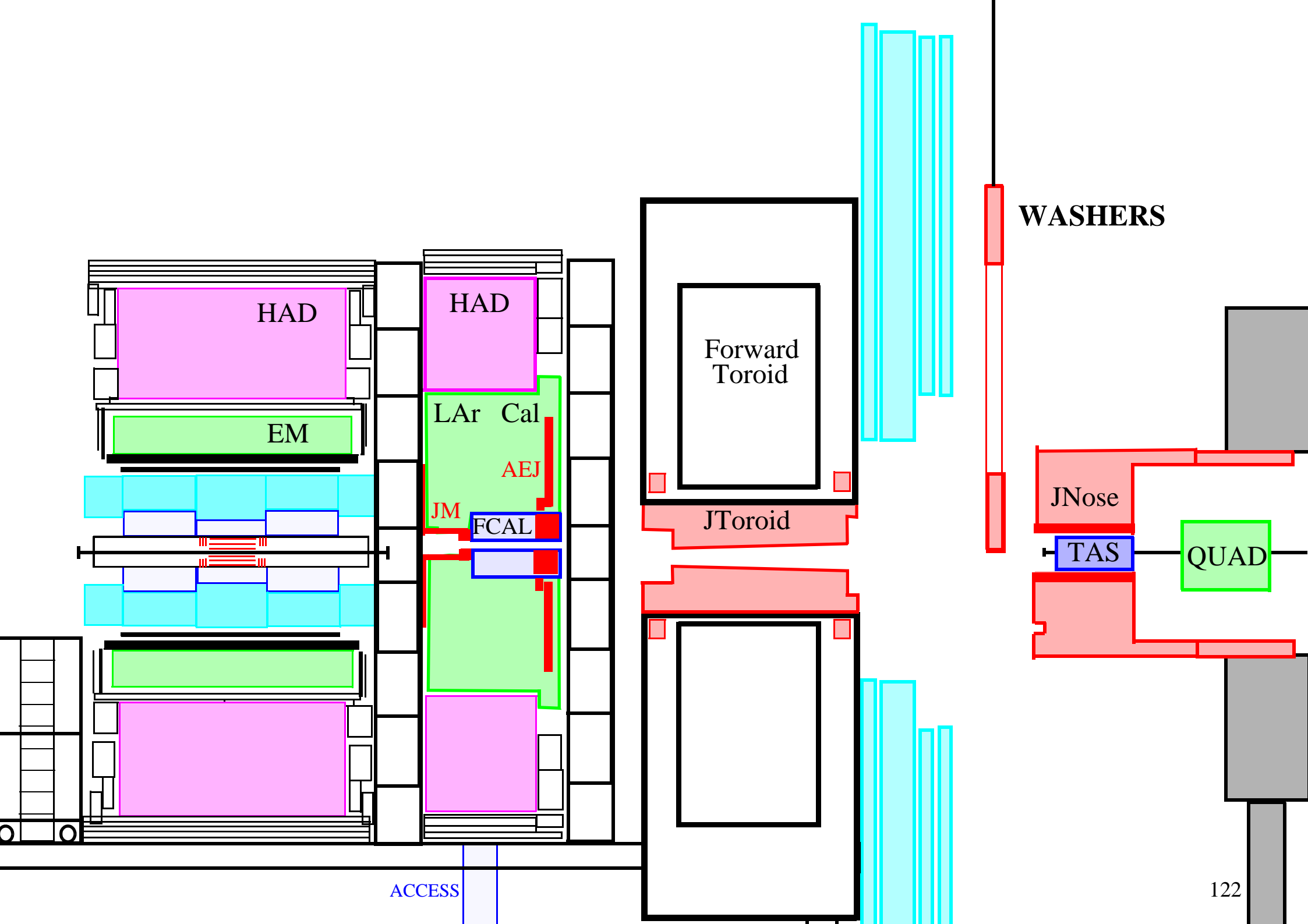

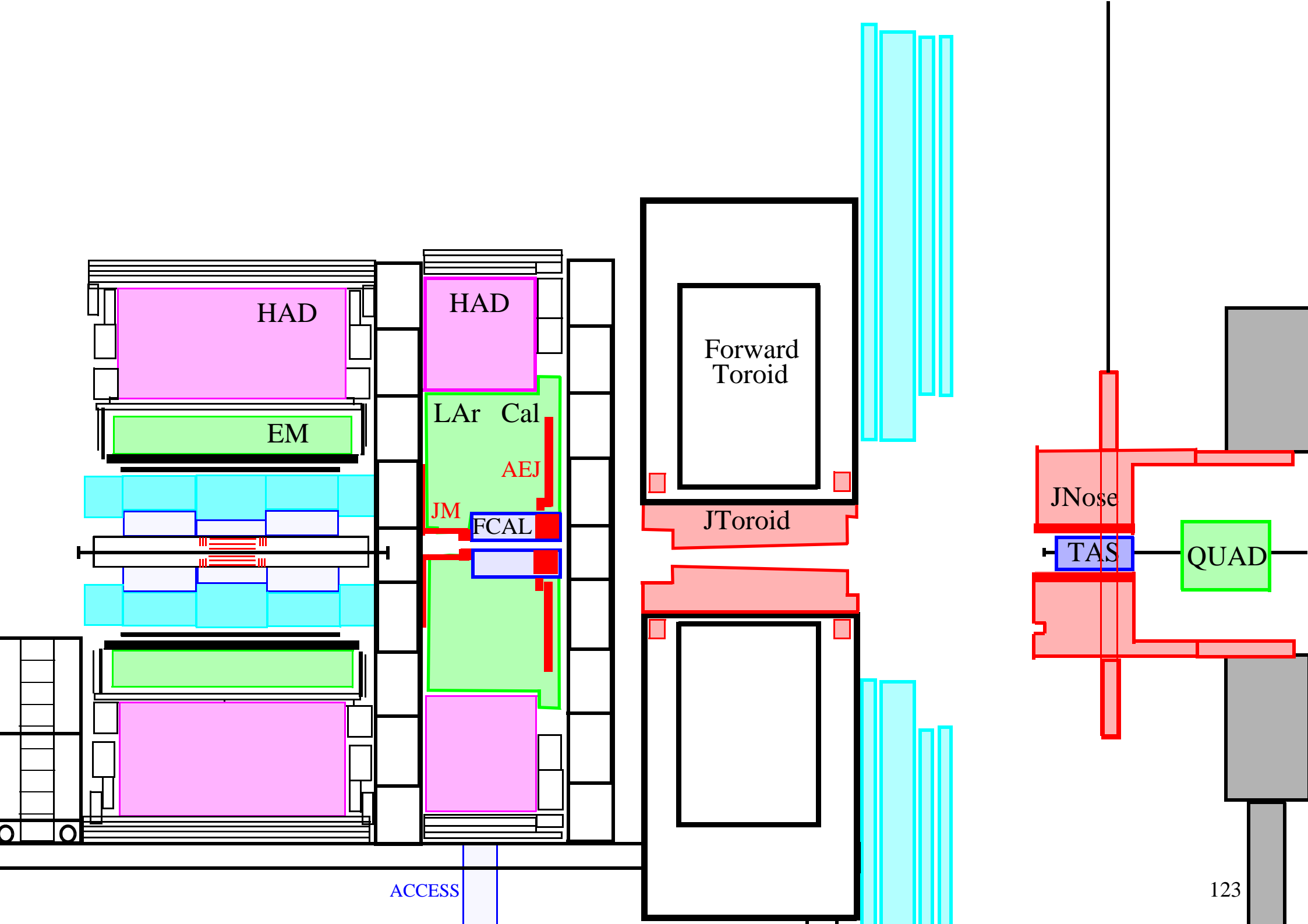

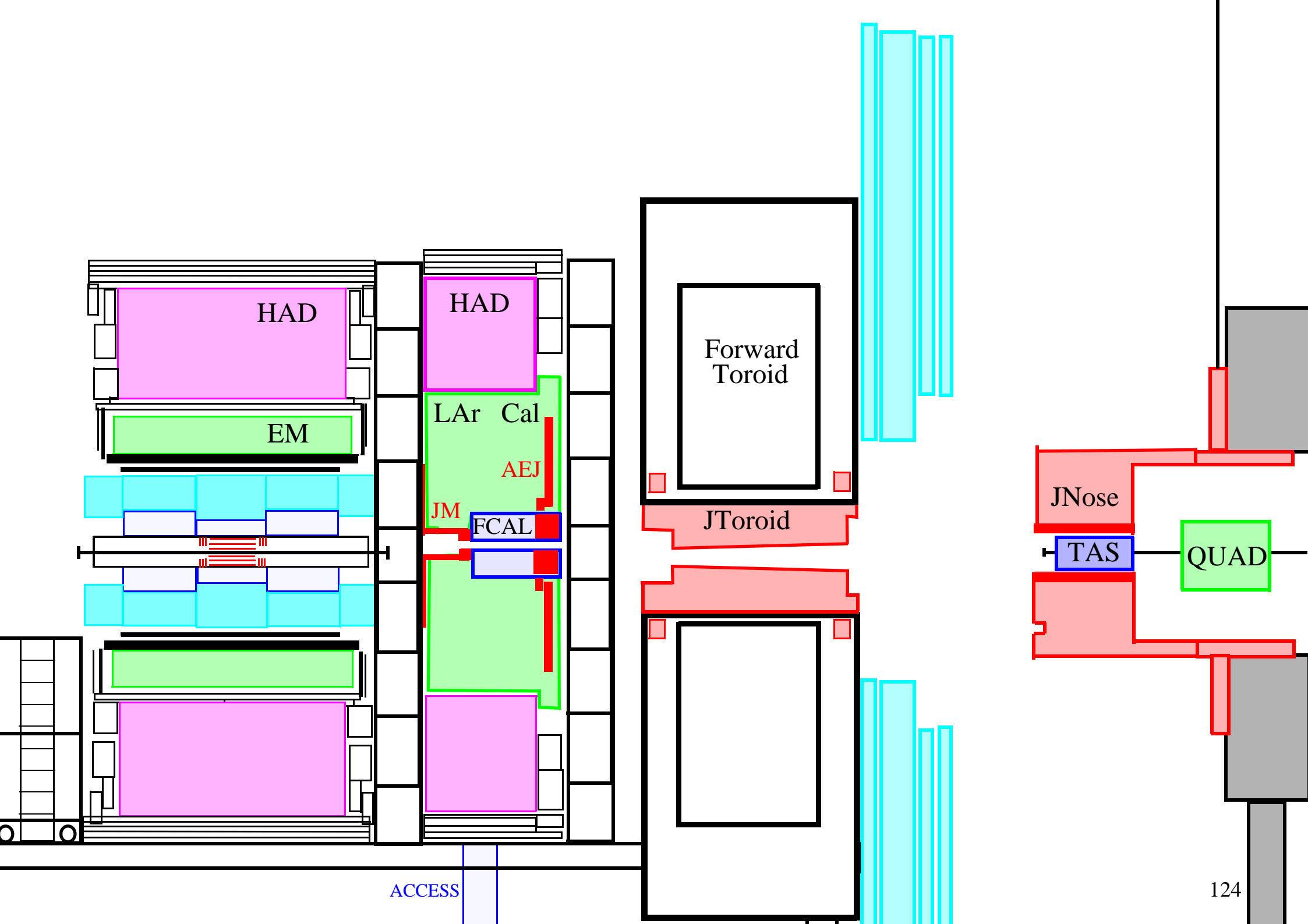

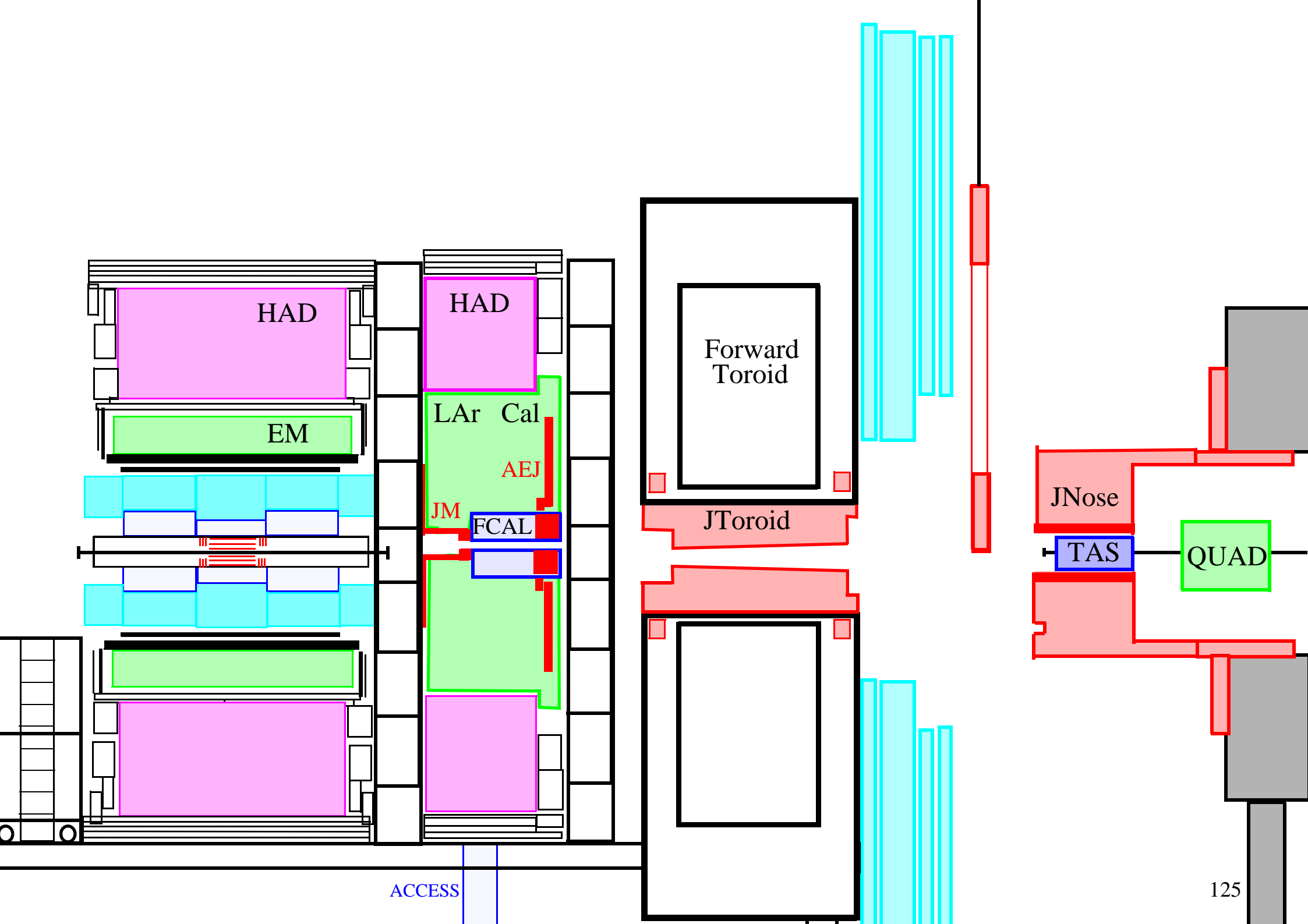

ACCESS

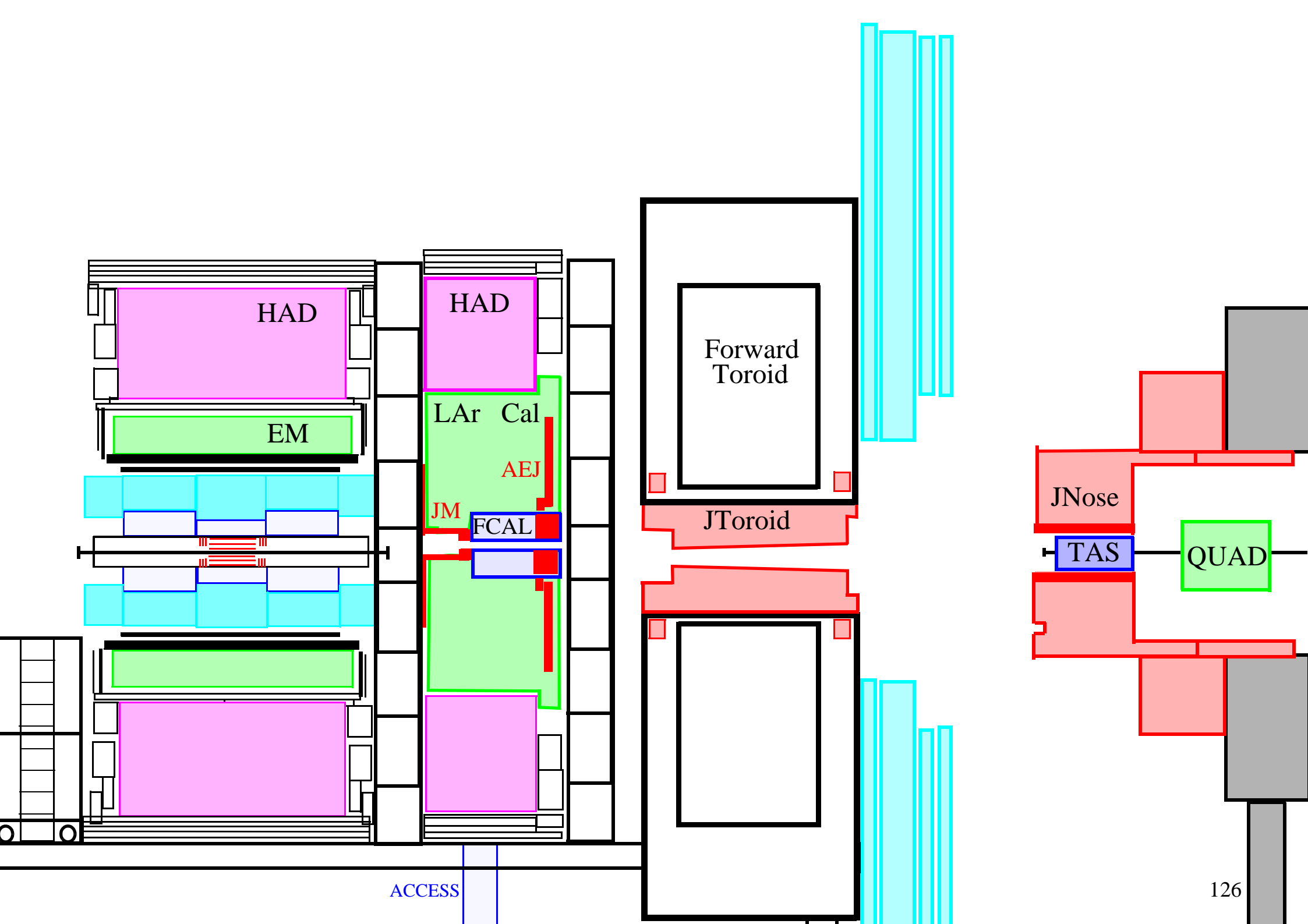

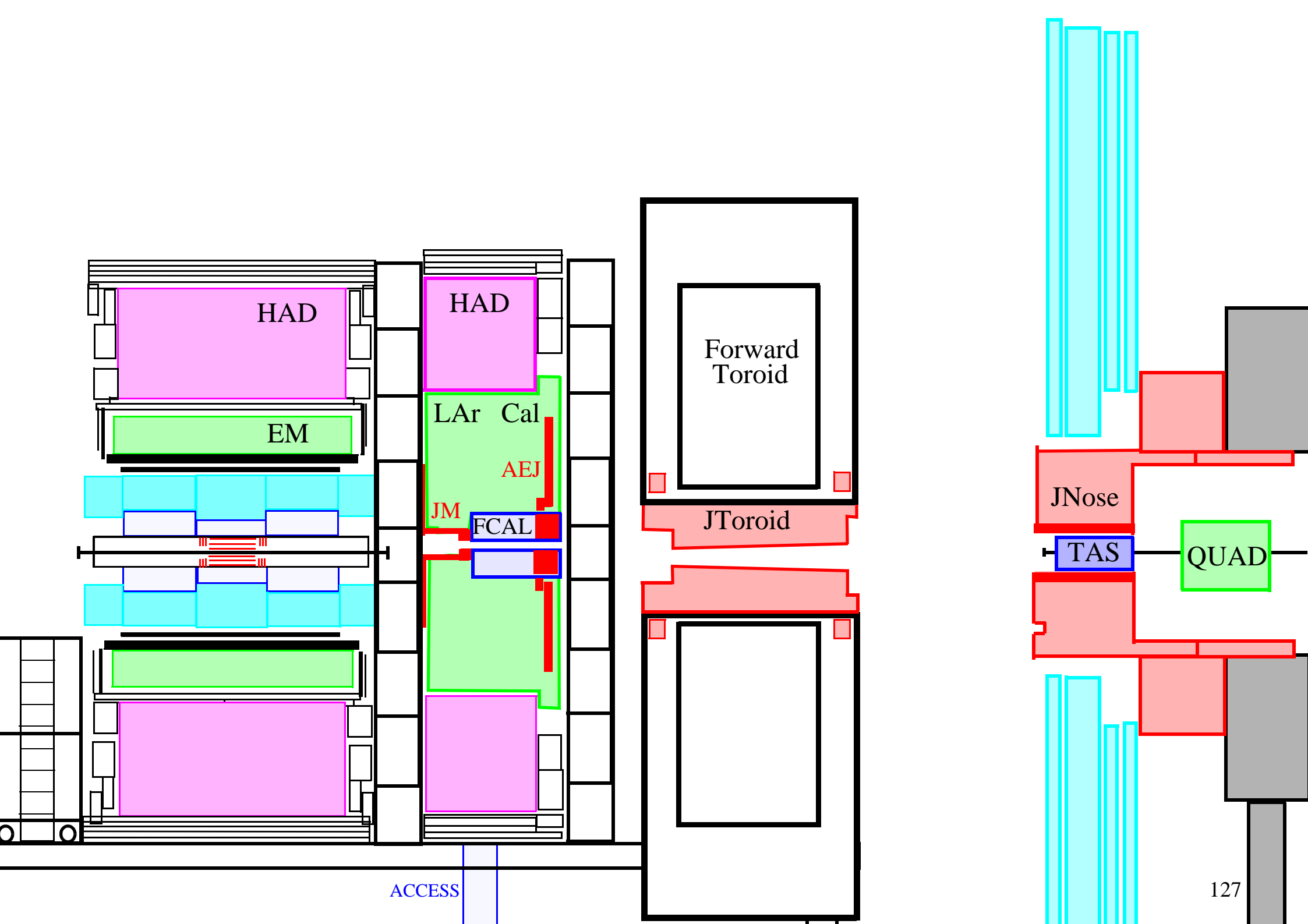

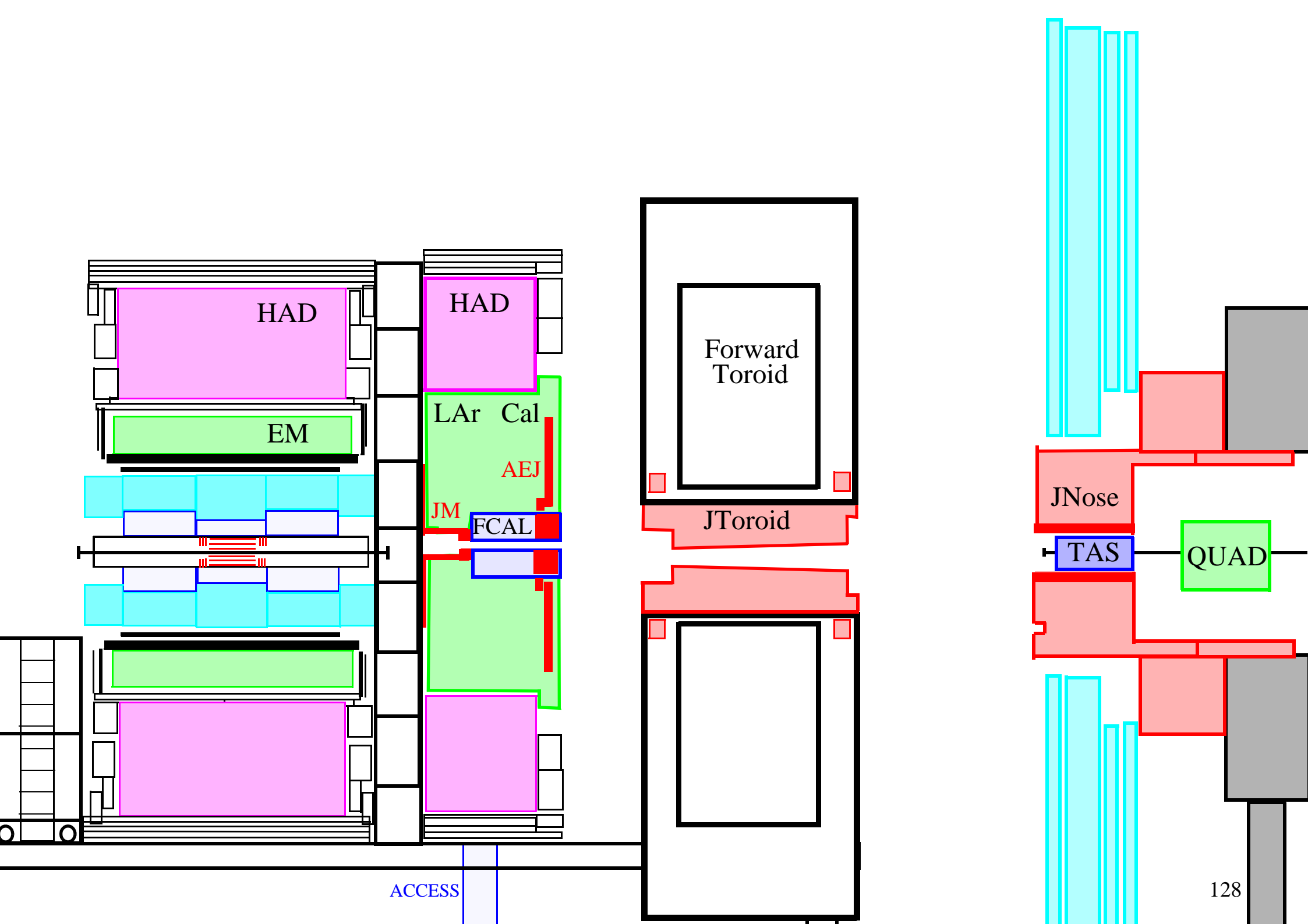

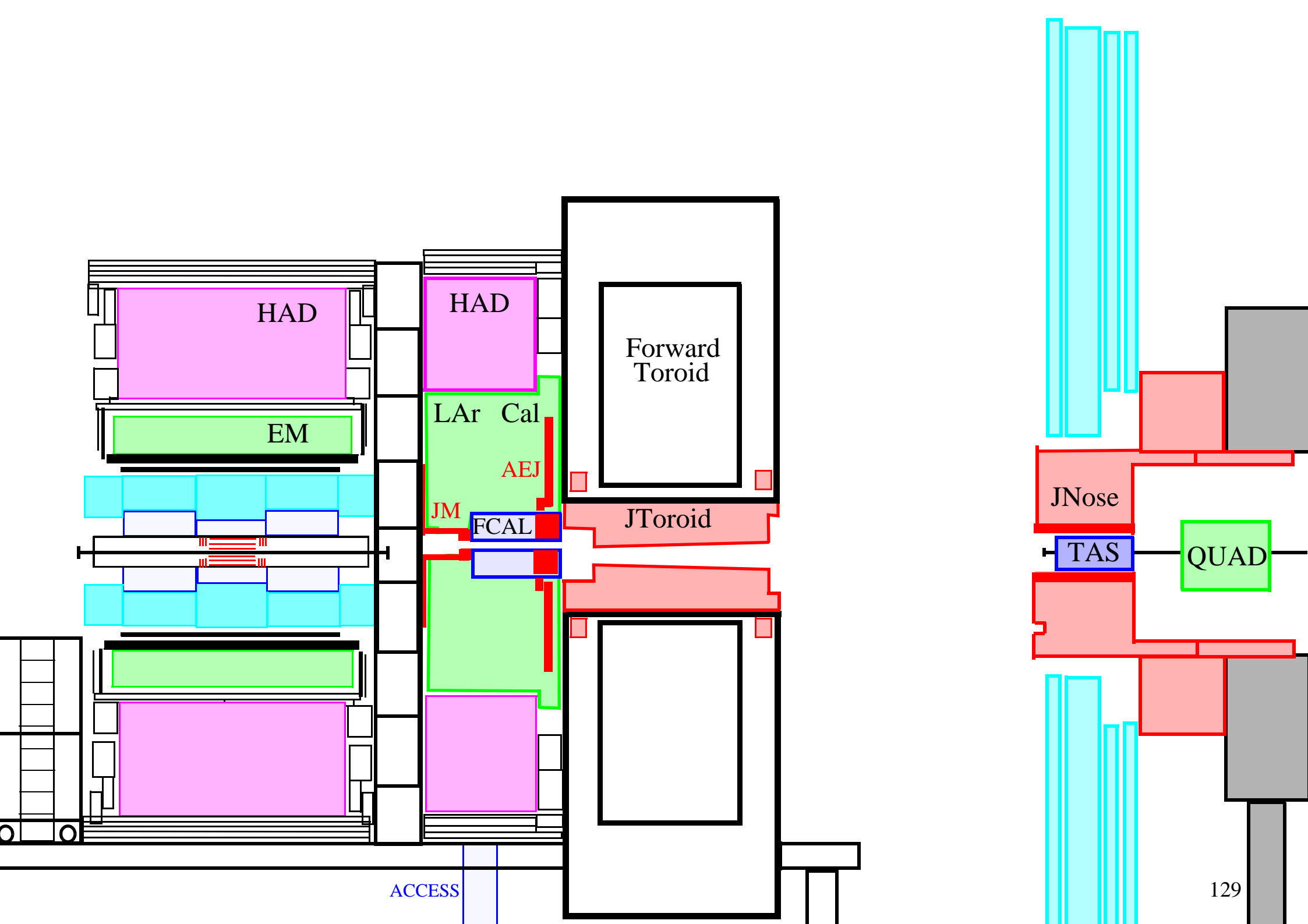

ACCESS

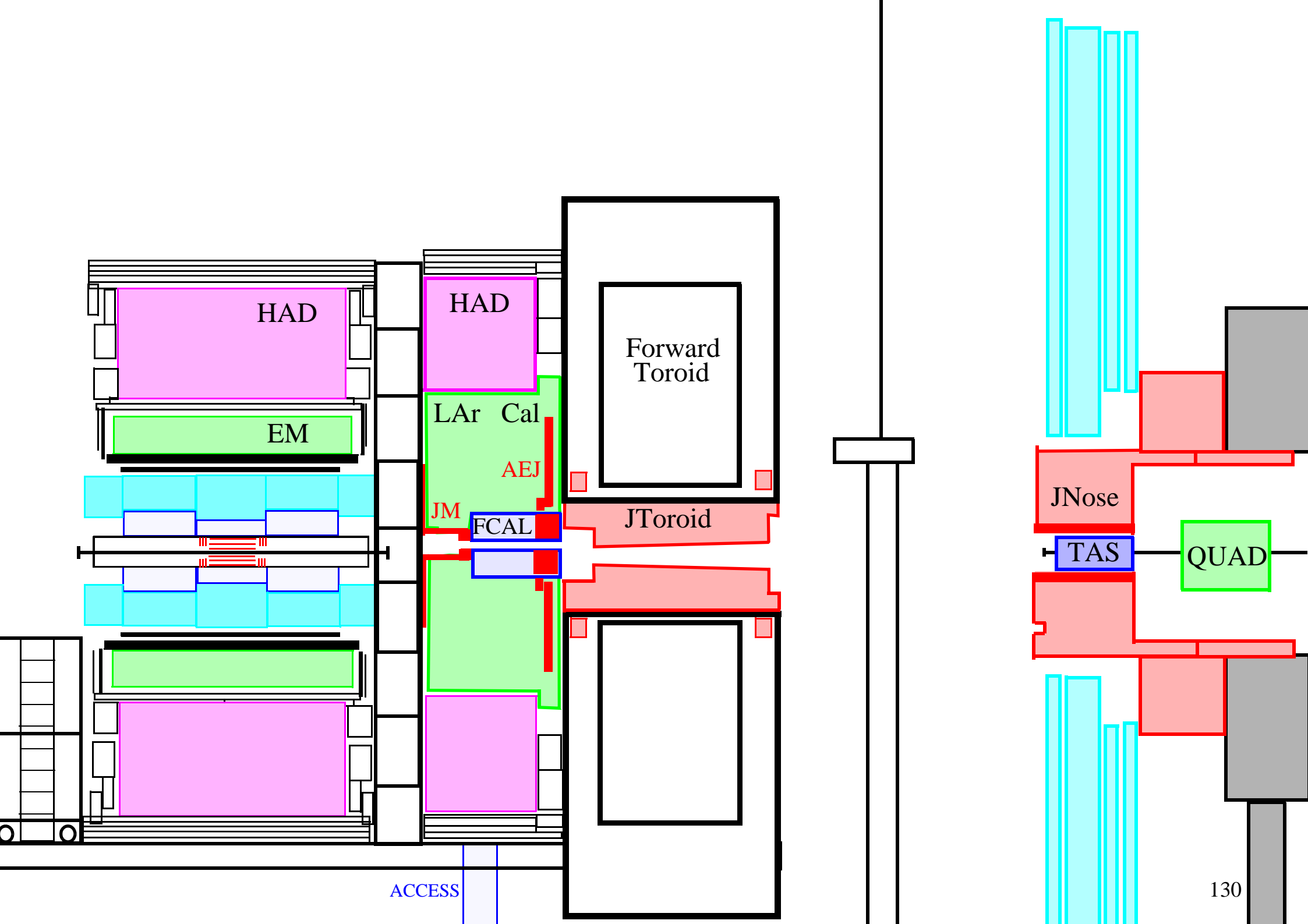

ACCESS

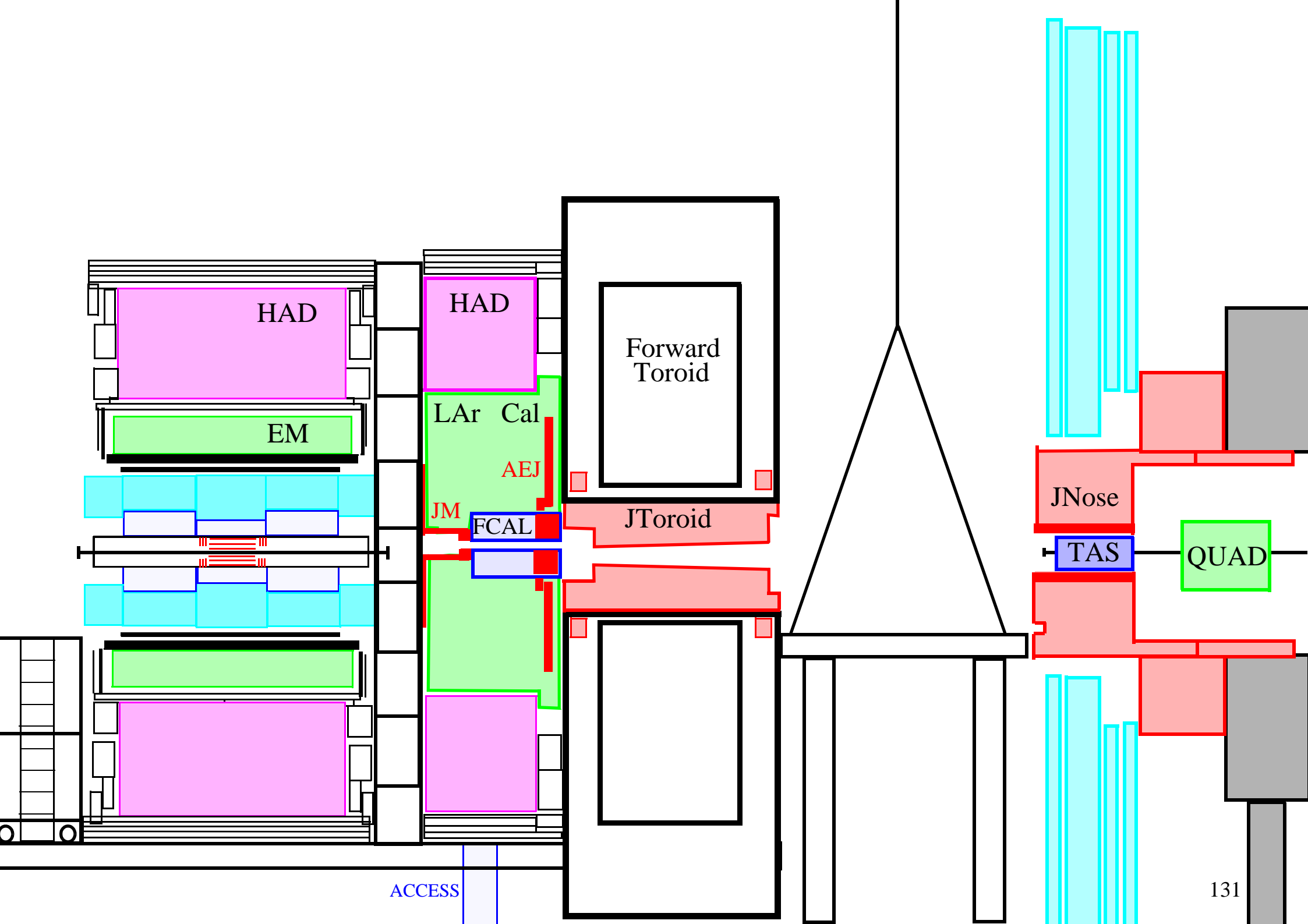

ACCESS

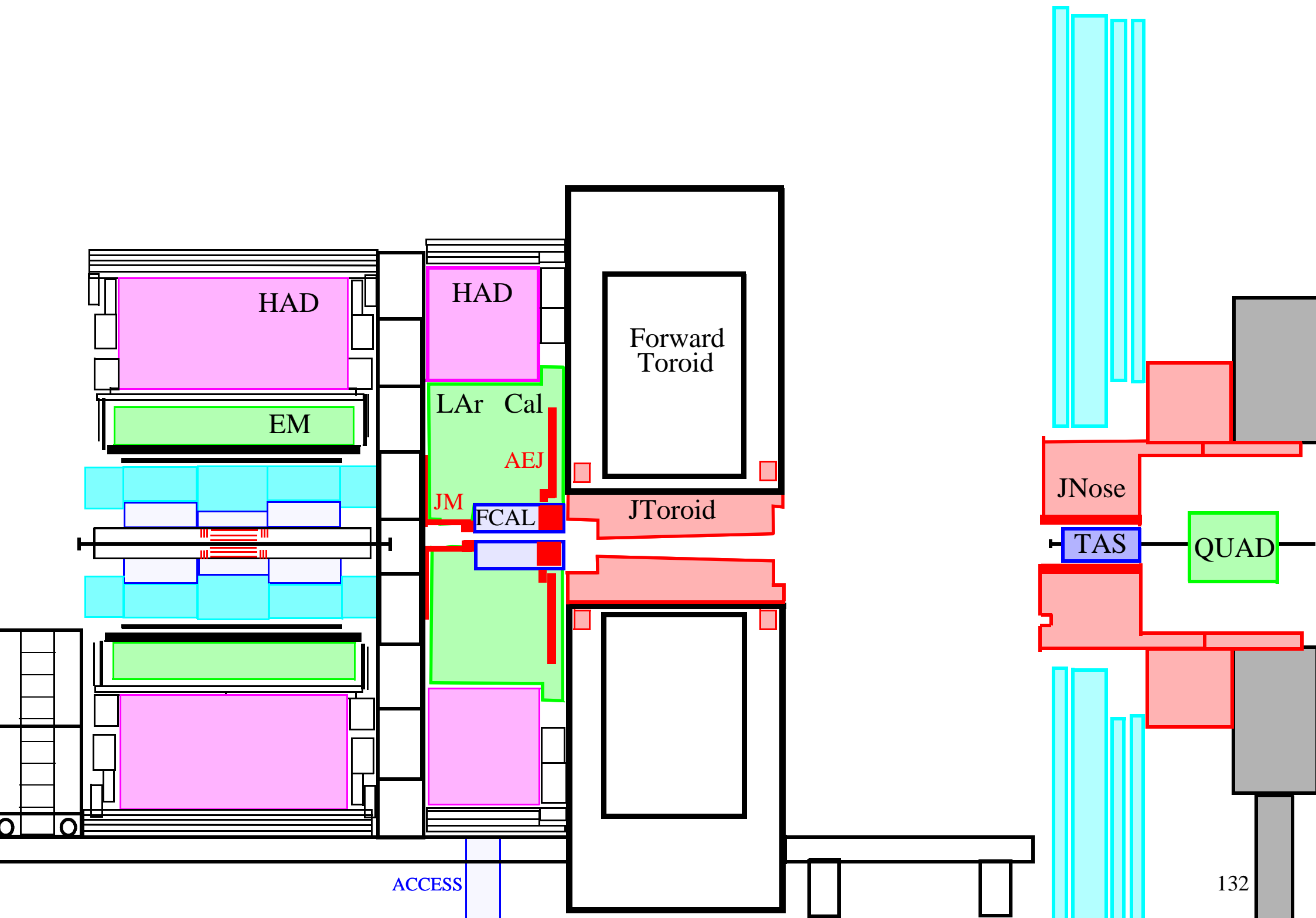

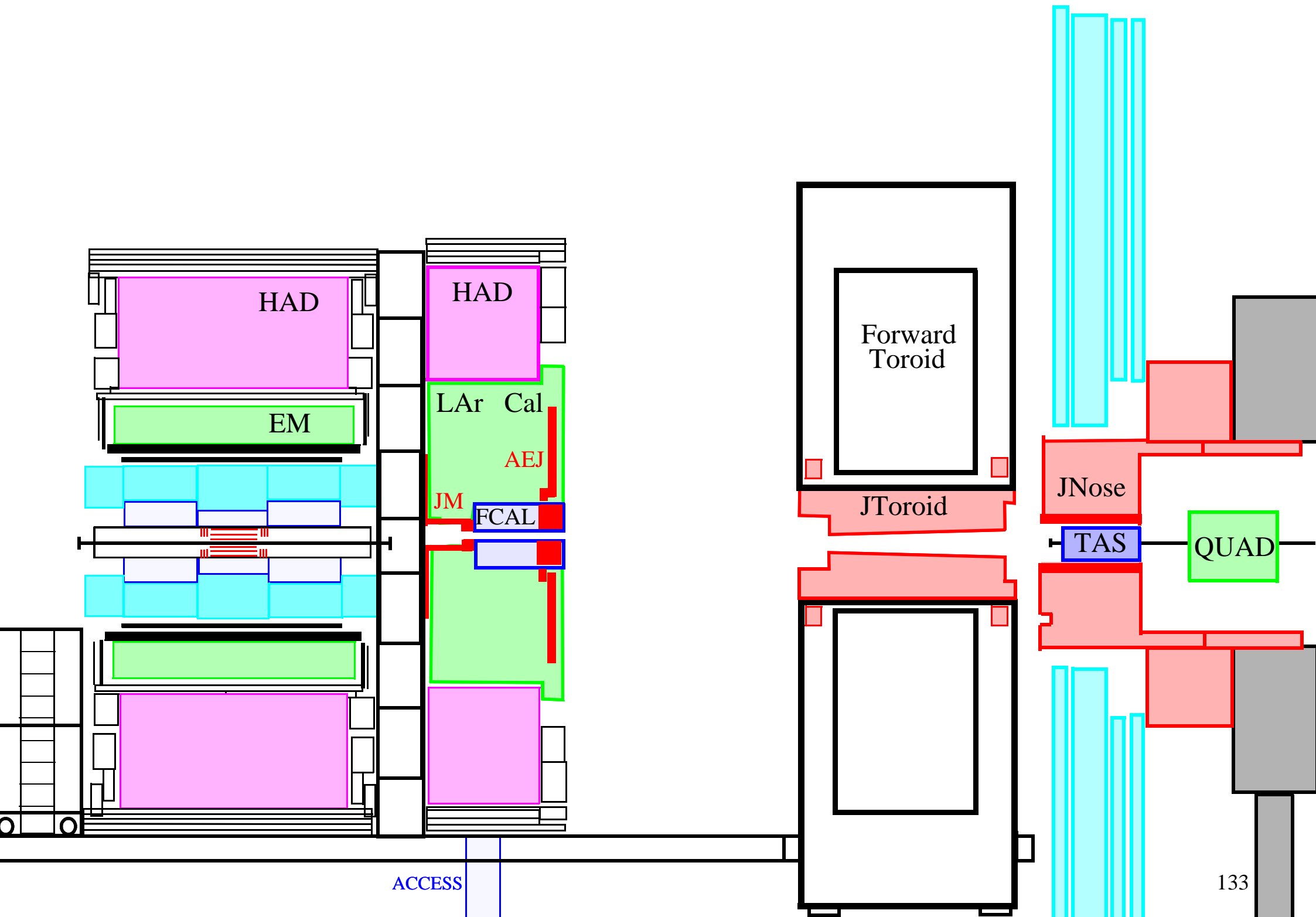

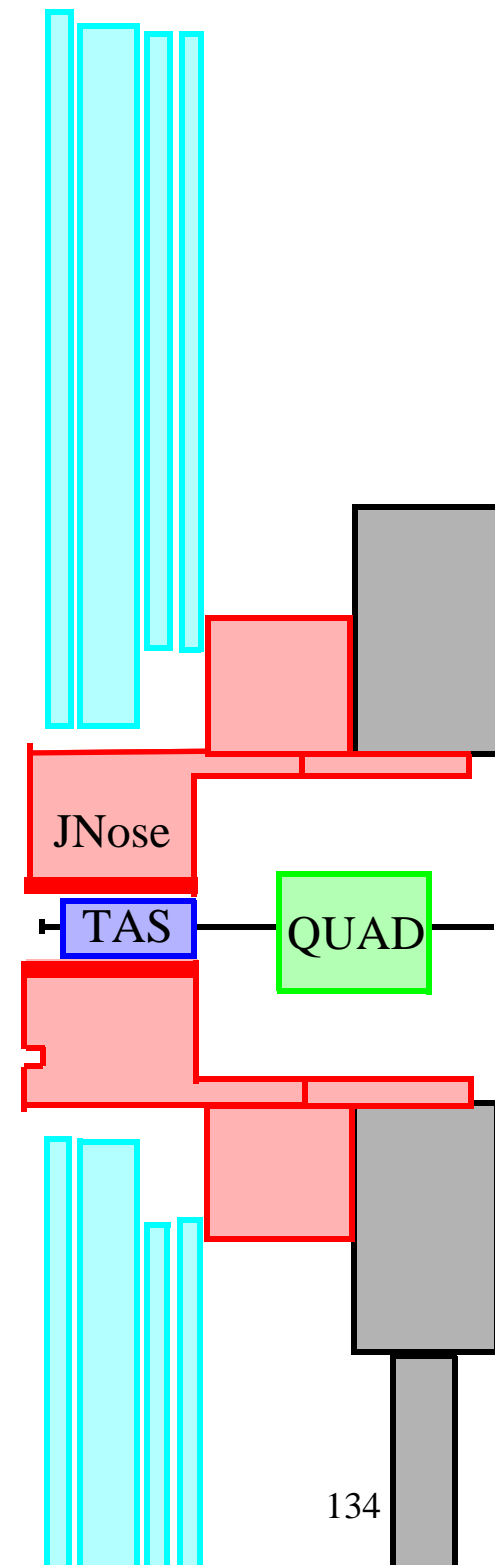
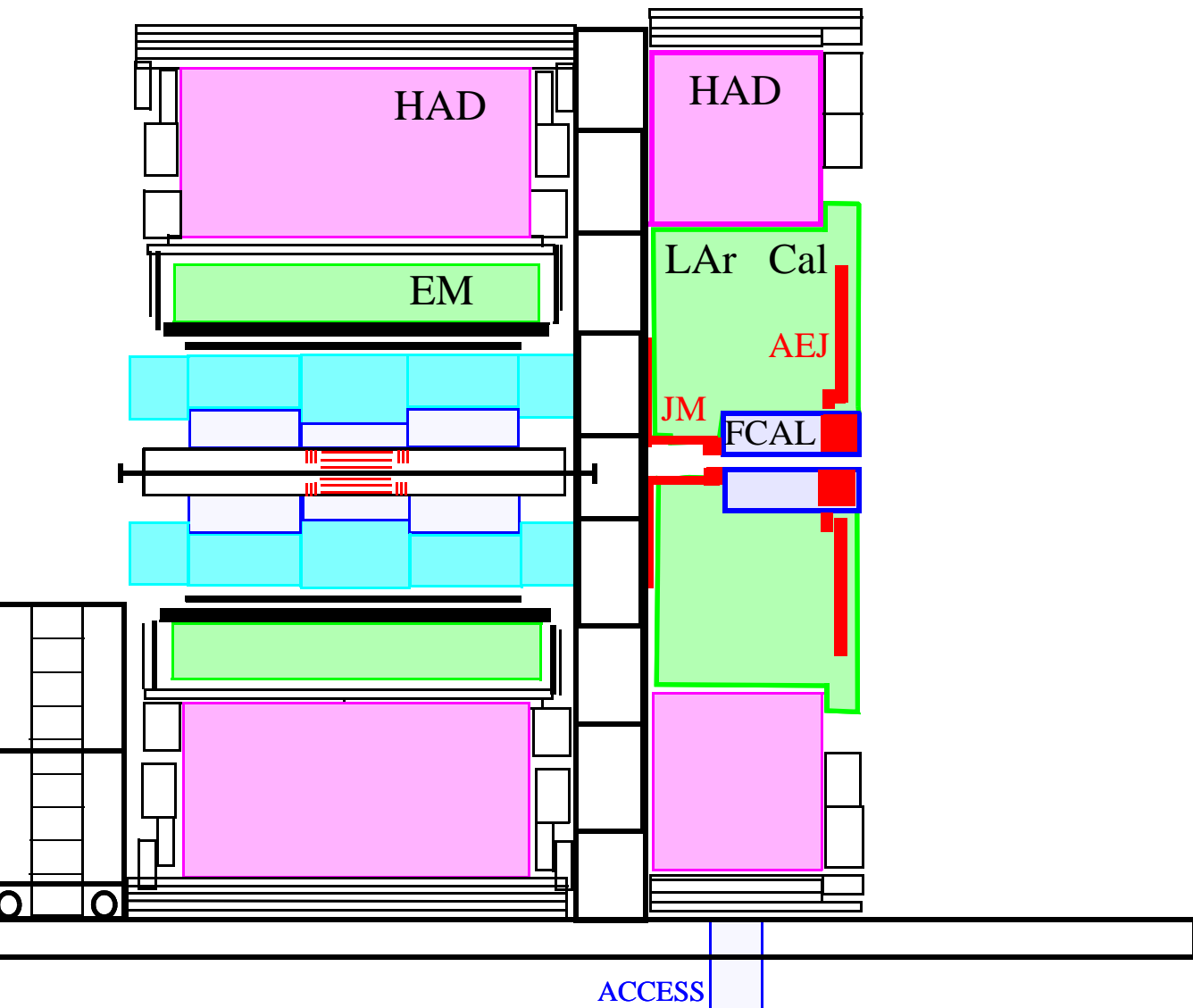

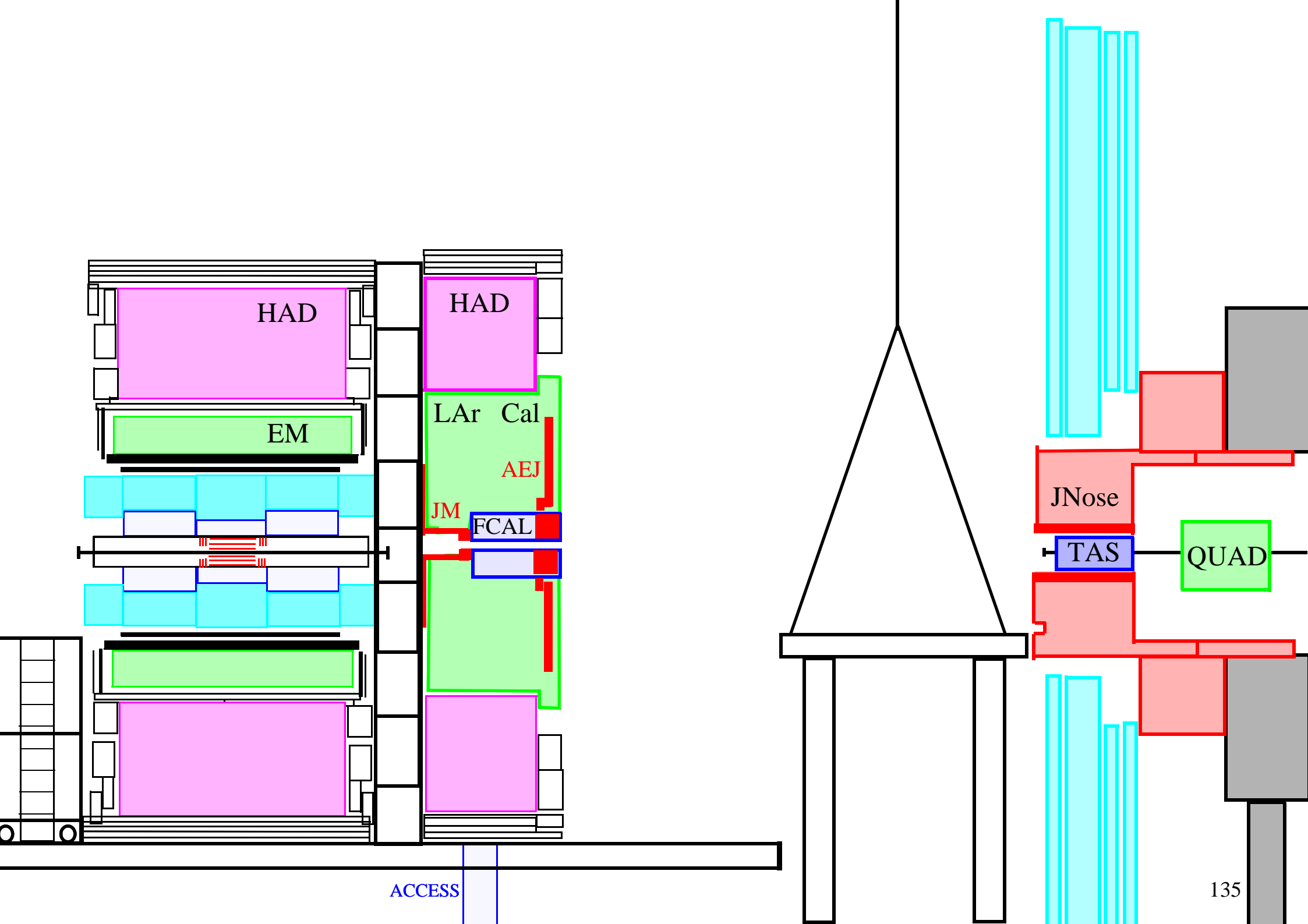

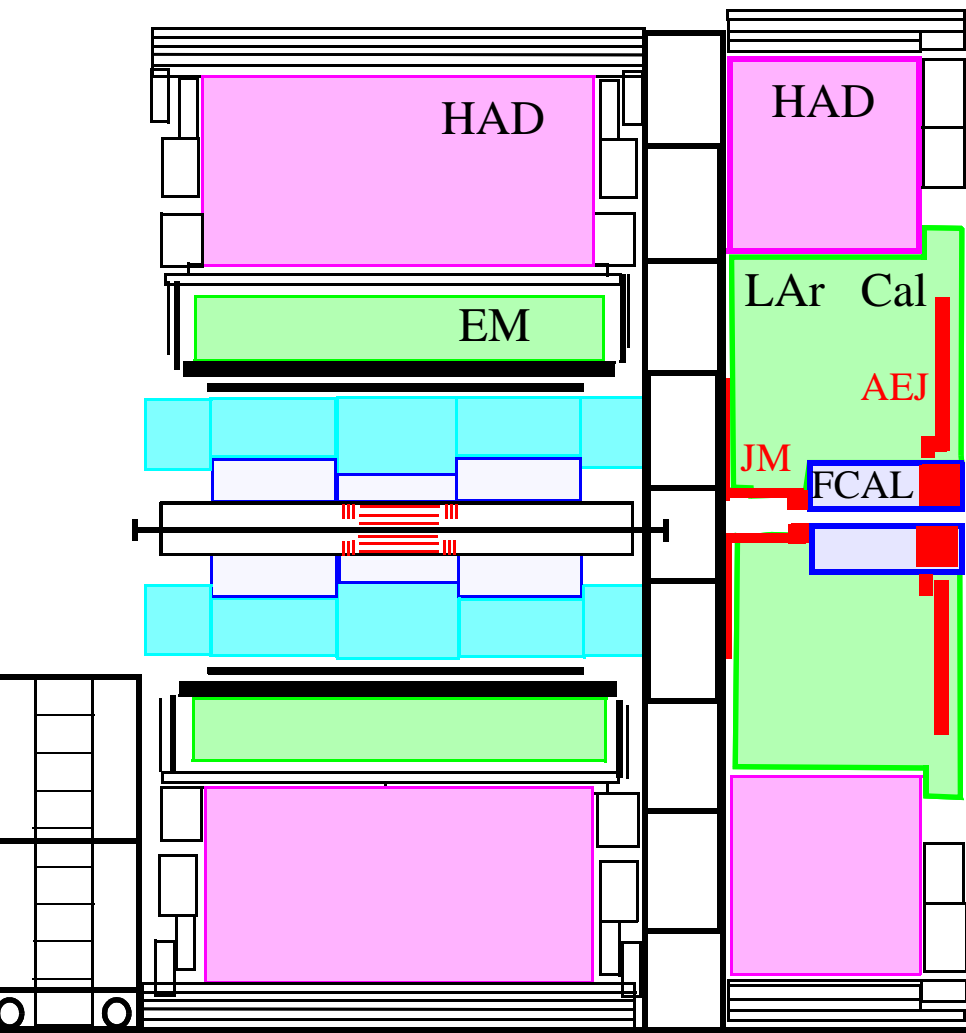

ACCESS

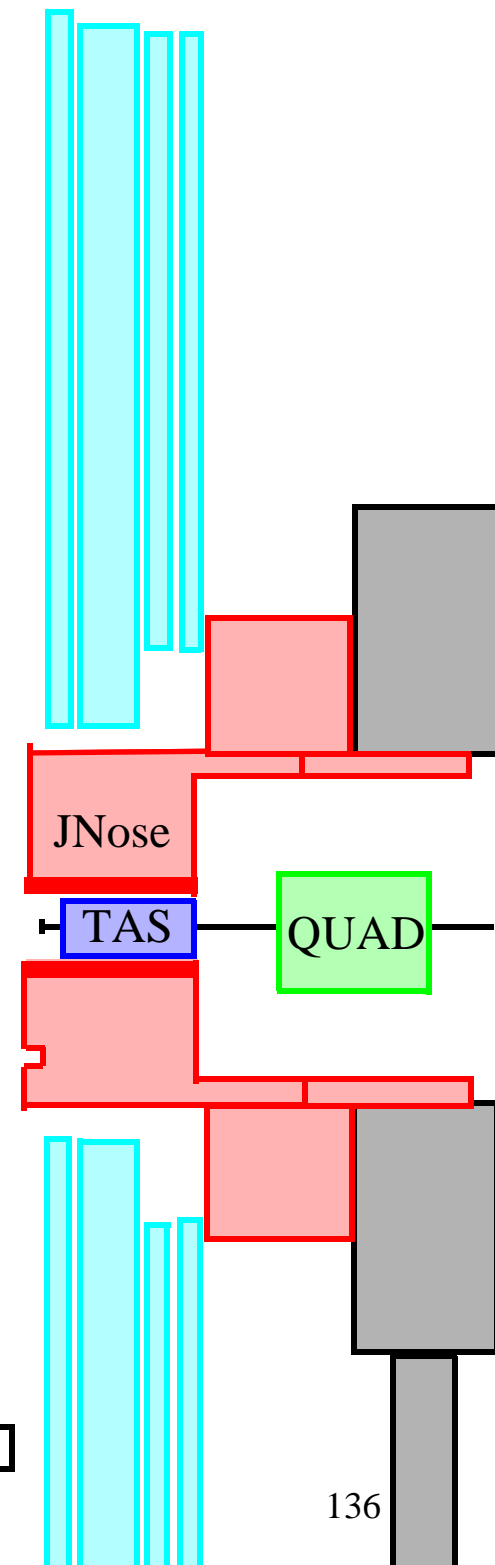

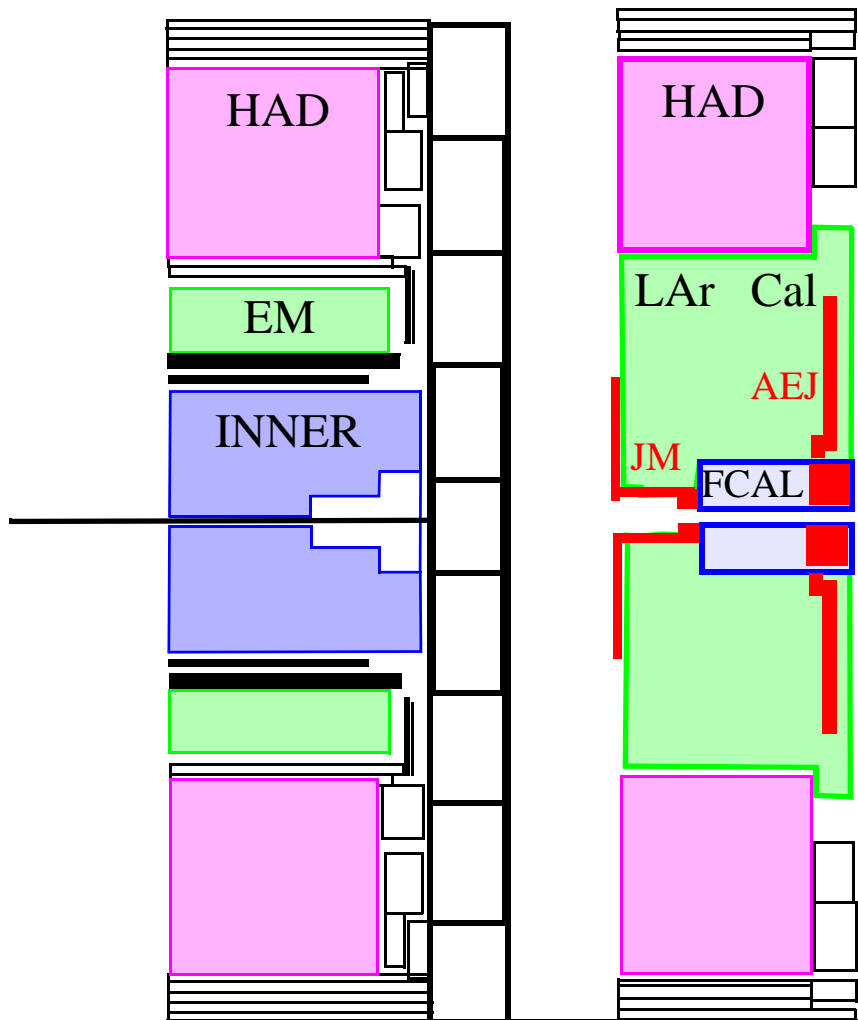

ACCESS

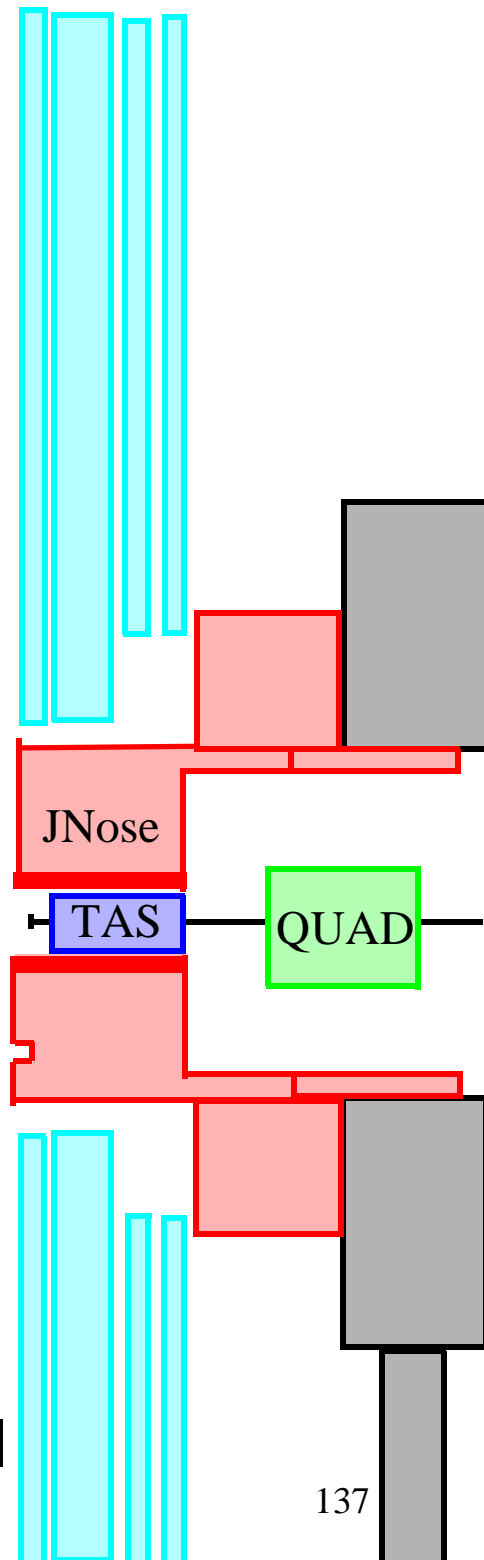

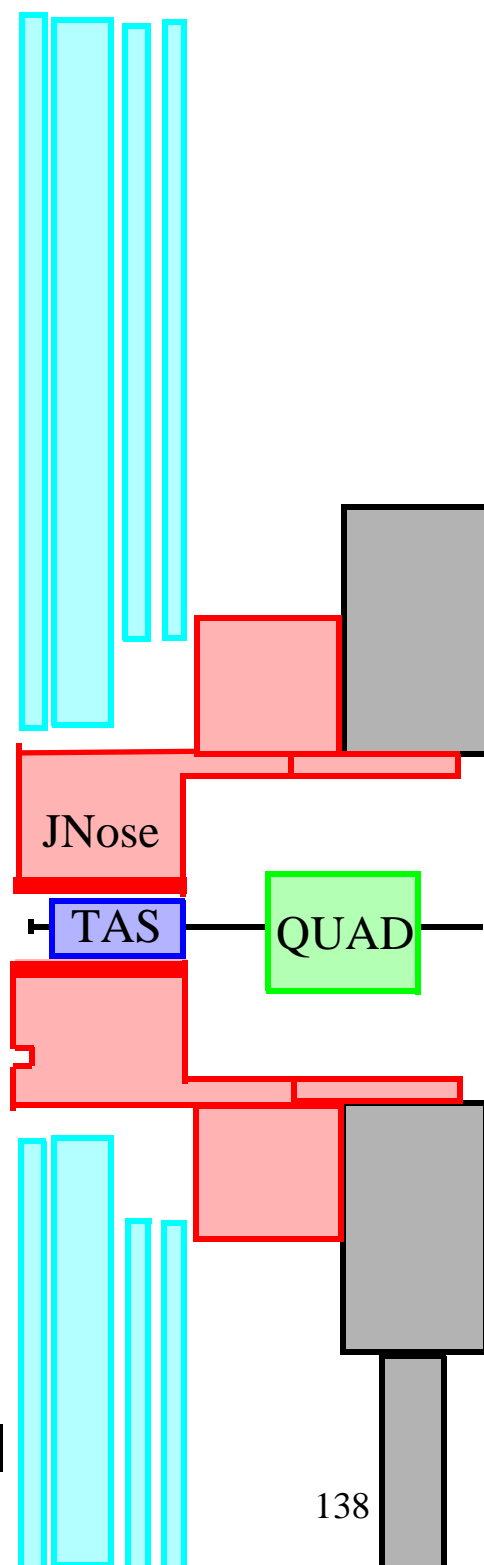
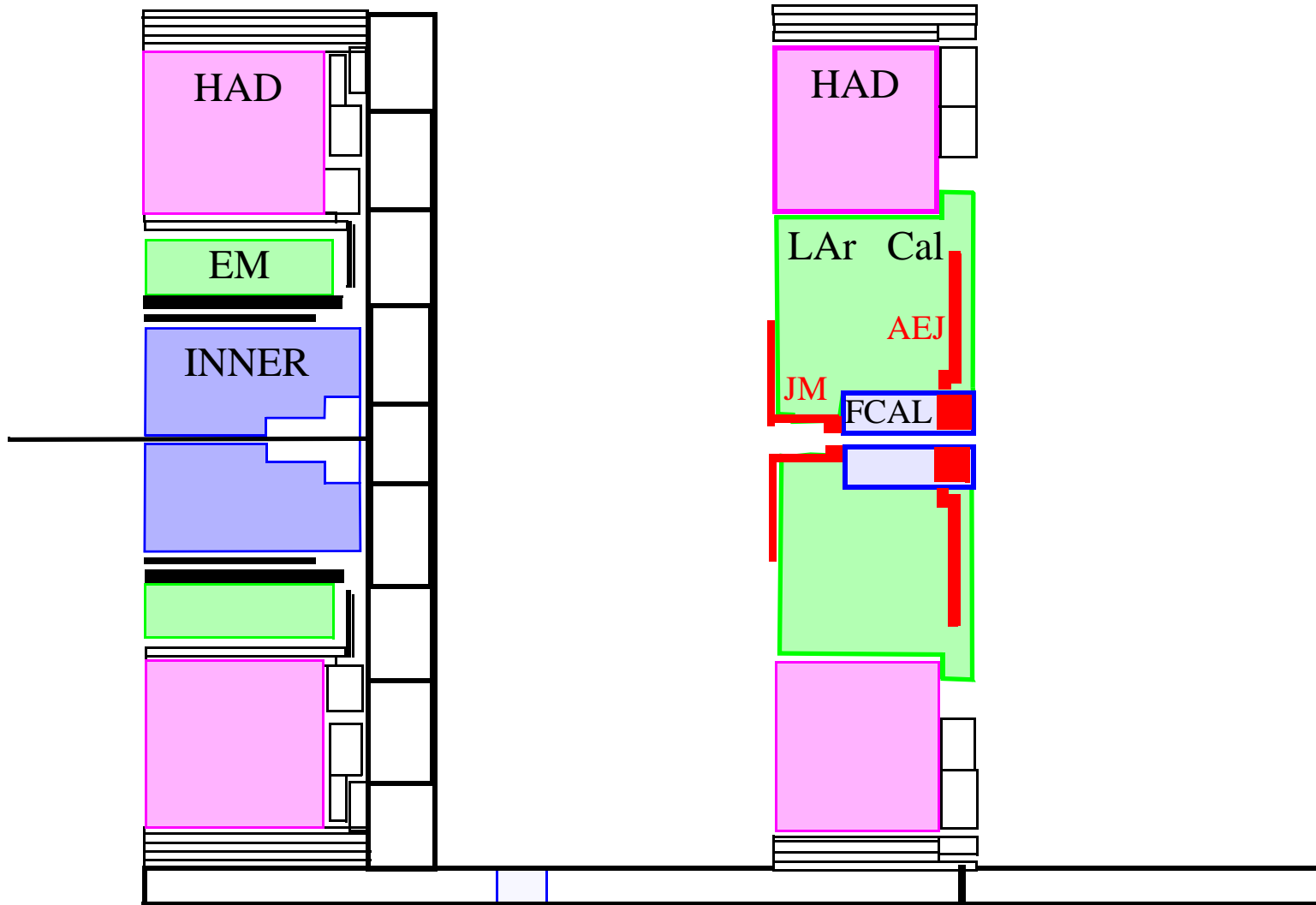

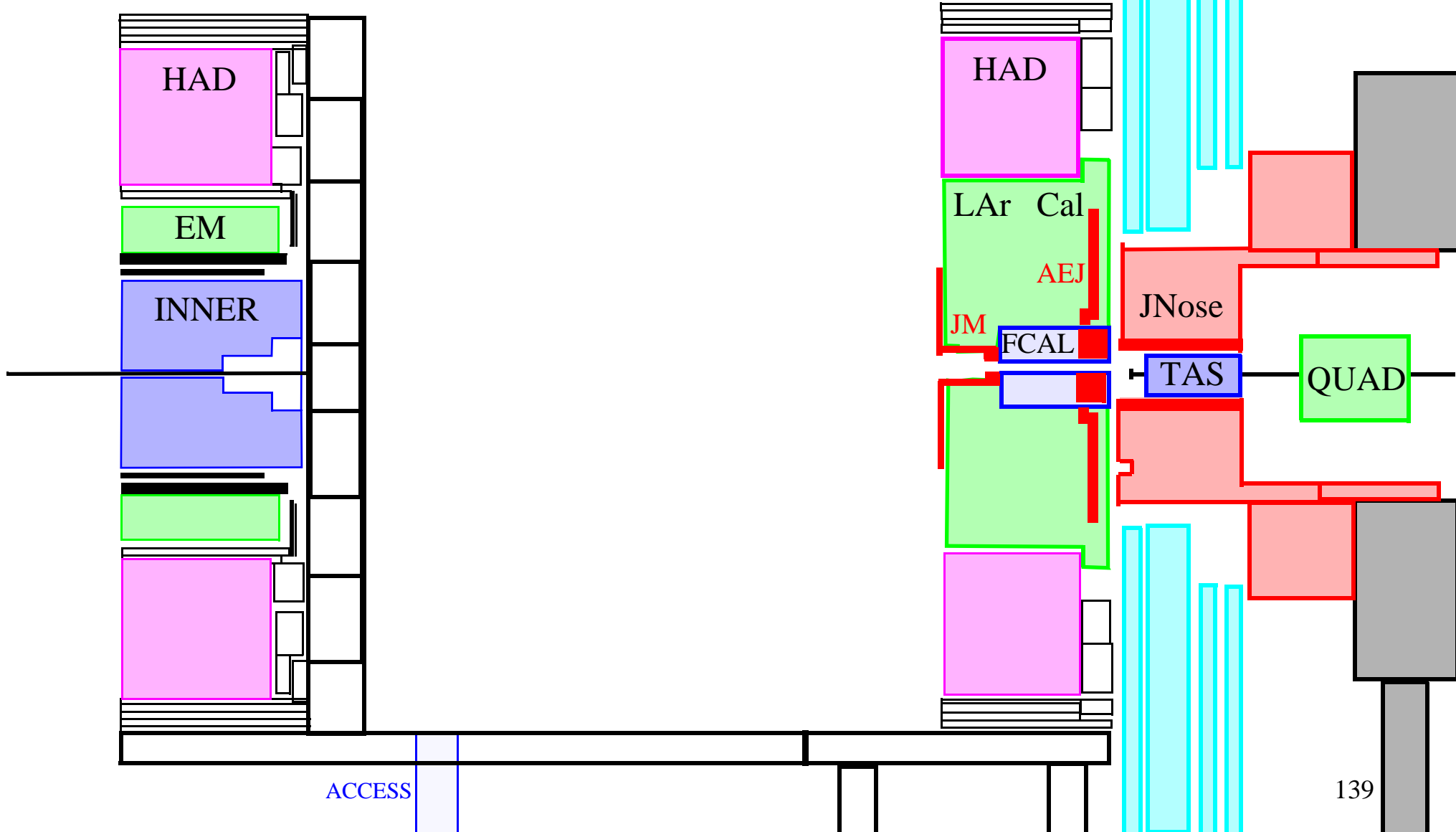

ACCESS

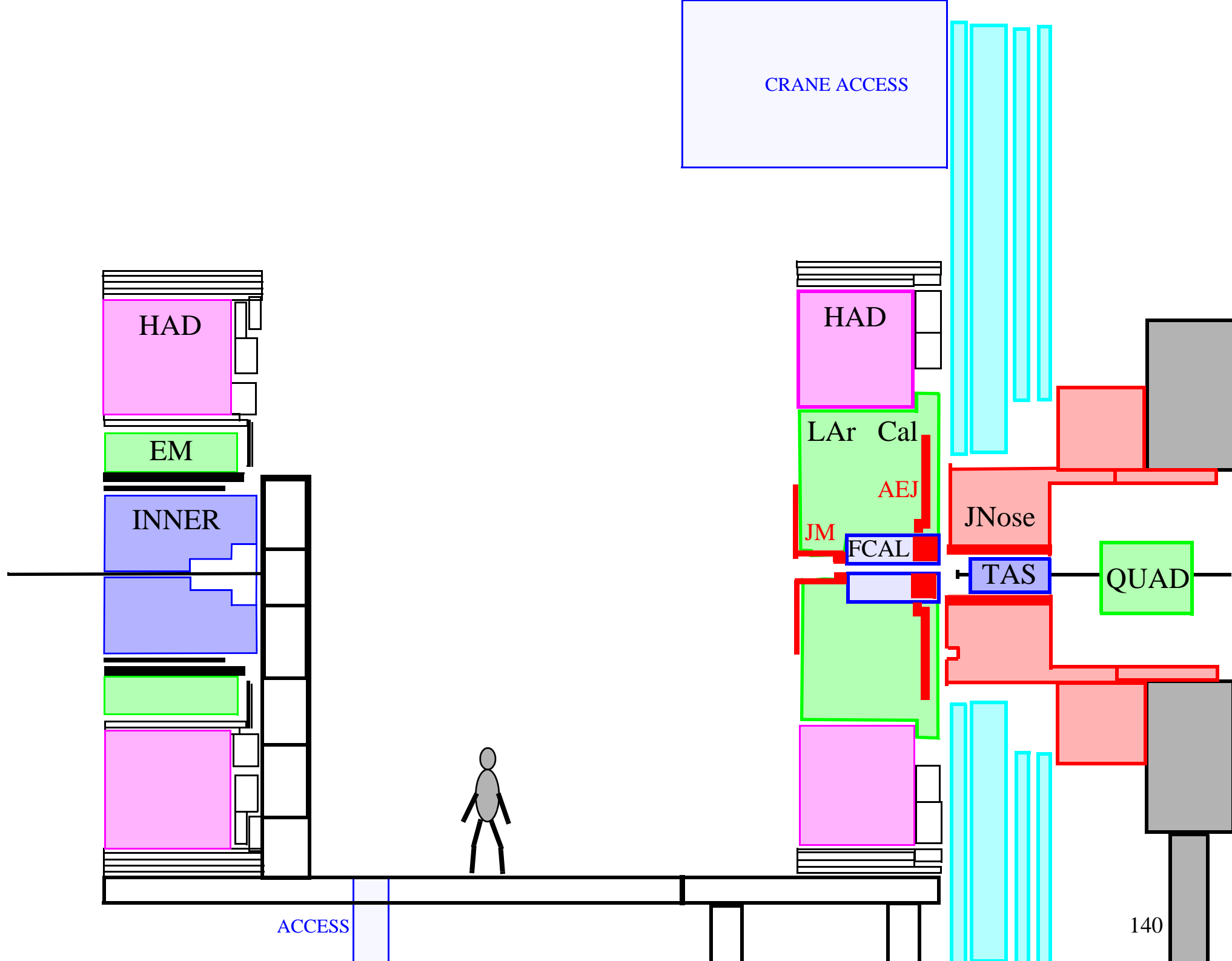

CRANE ACCESS

HAD

EM

INNER

HAD

LAr Cal

AEJ

JM

FCAL

JNose

TAS

QUAD

ACCESS

140

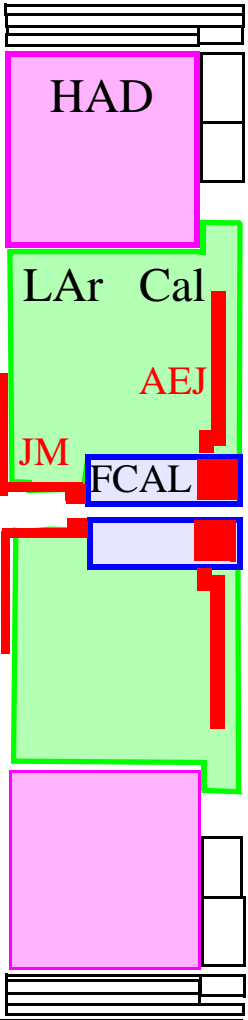
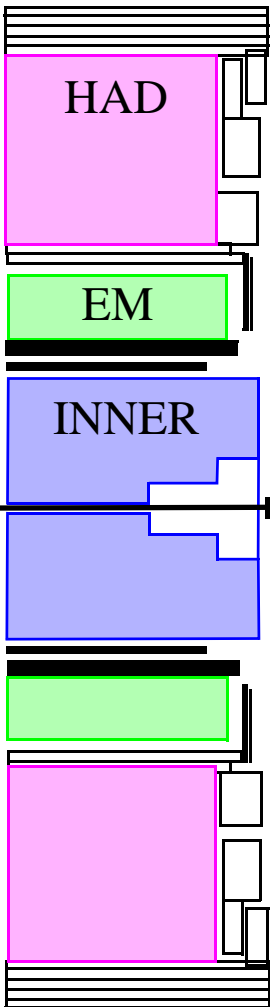
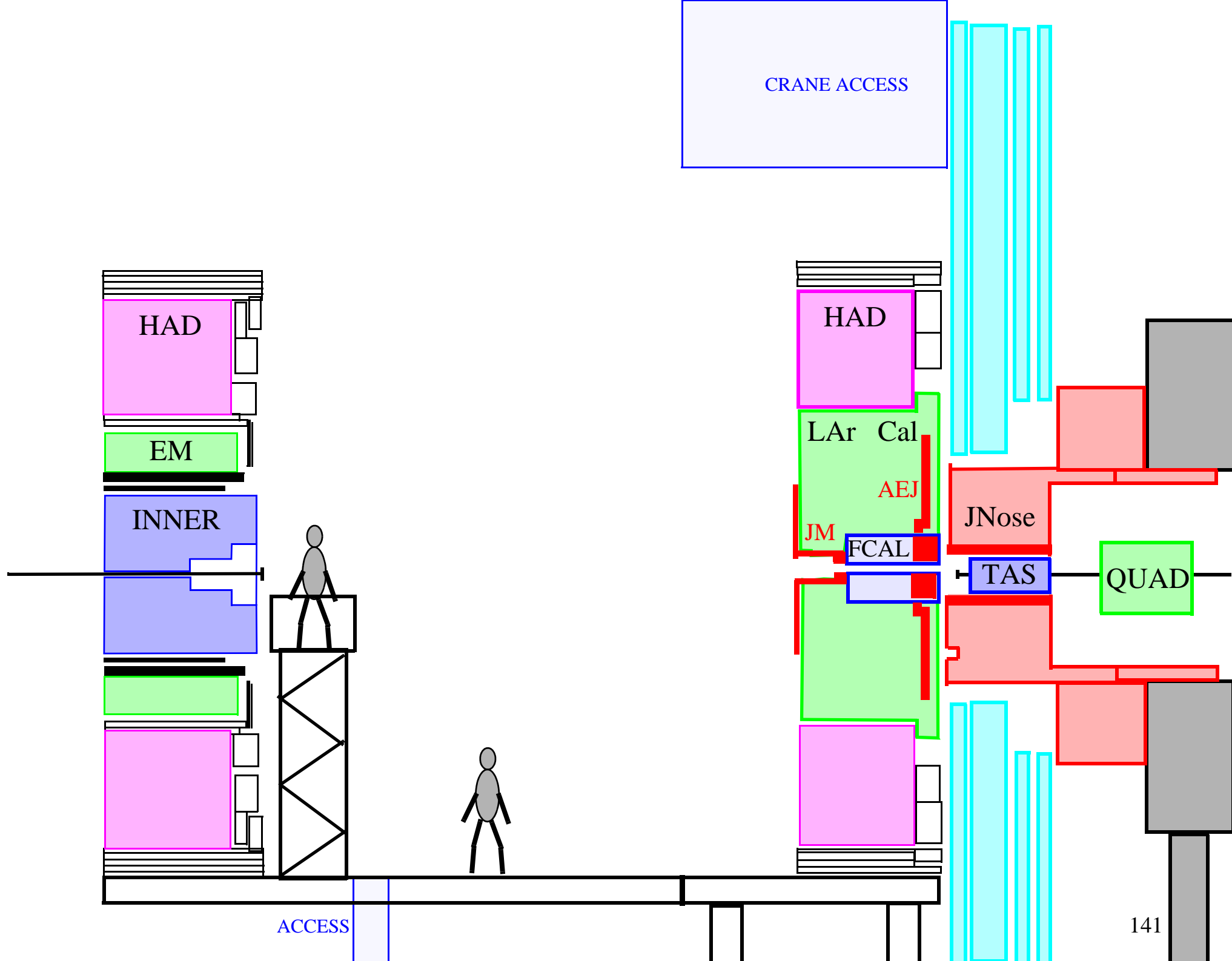

CRANE ACCESS

ACCESS

QUAD

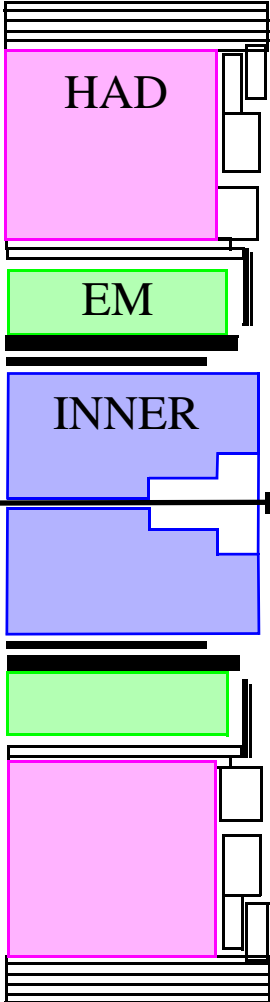
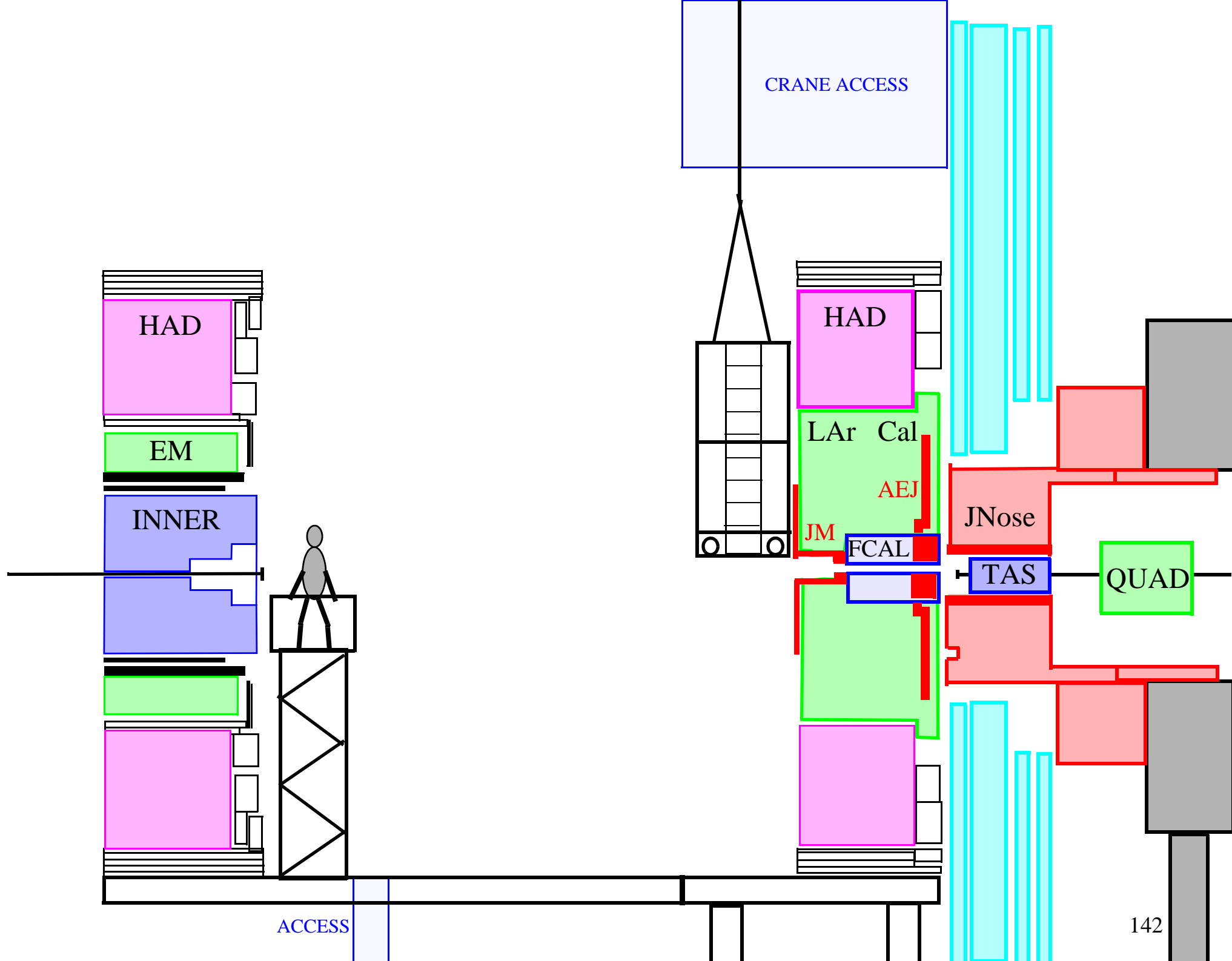

HAD

EM

INNER

HAD

ACCESS

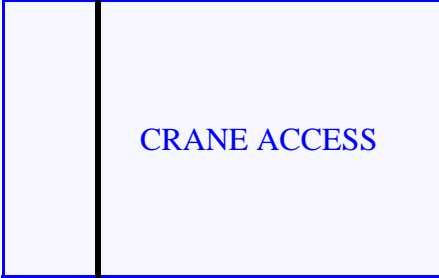

CRANE ACCESS

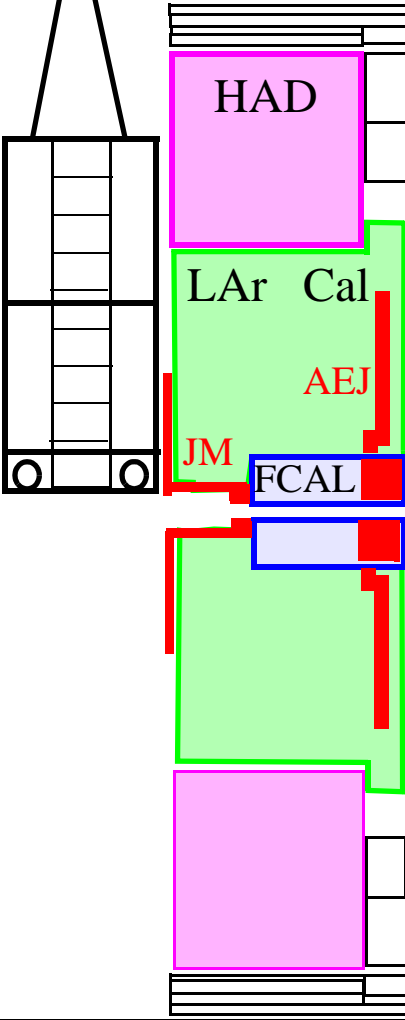

HAD

LAr Cal

HAD

AEJ

JM

FCAL

JNose

TAS

QUAD

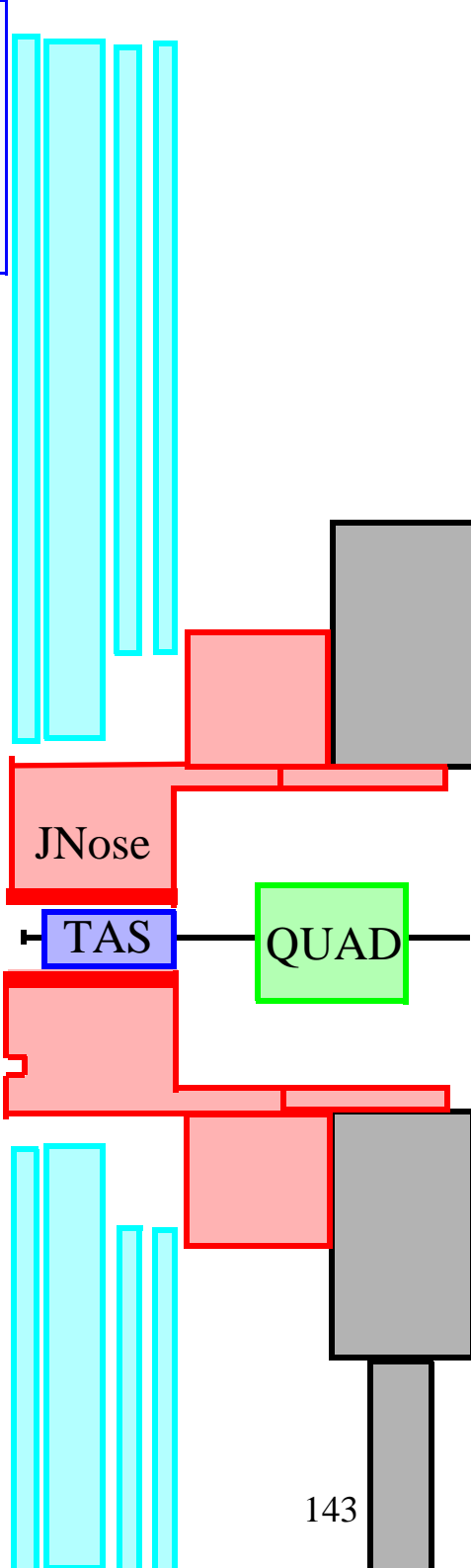
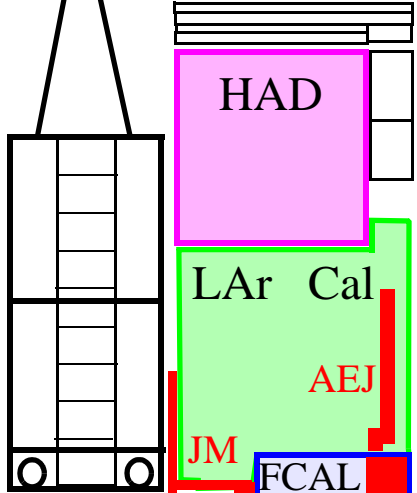
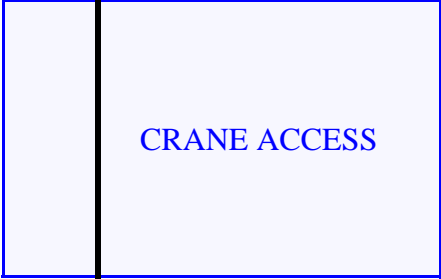
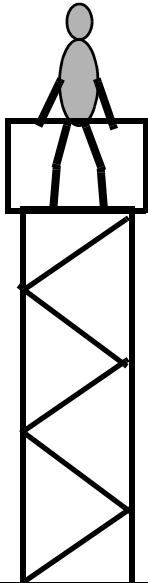
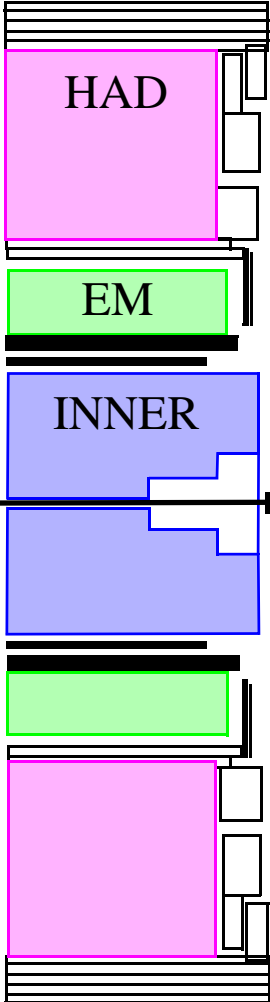
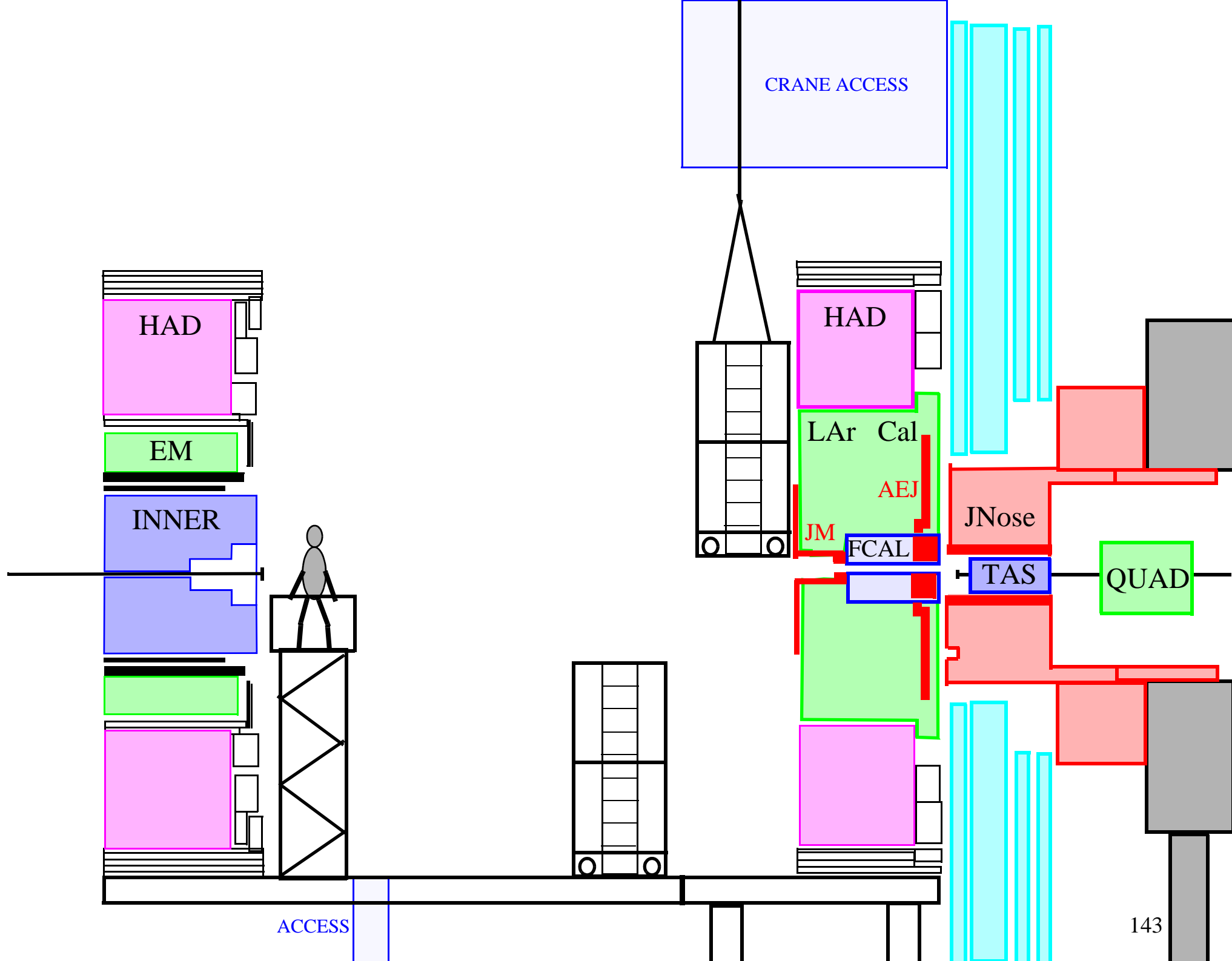

ACCESS

April 2007

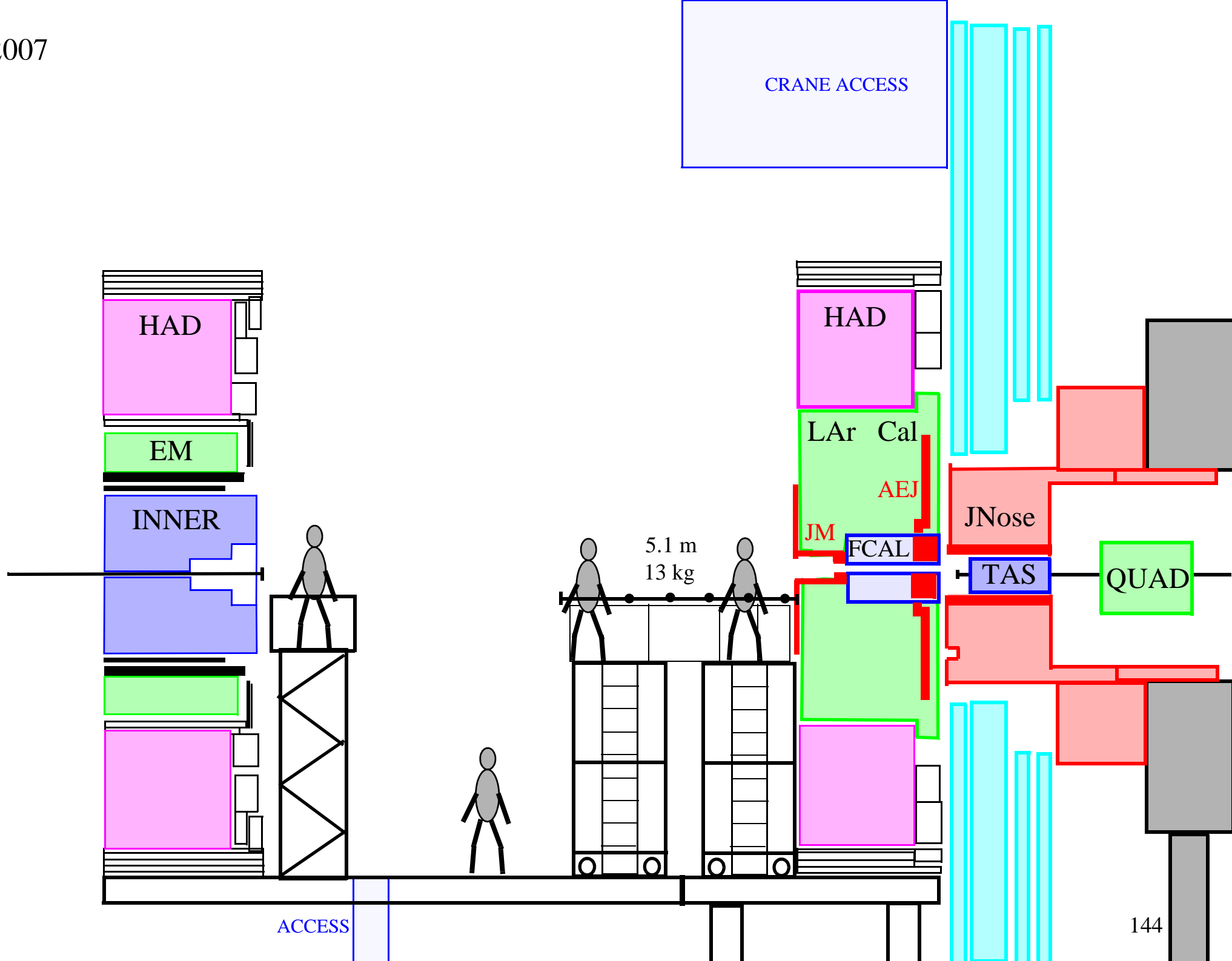

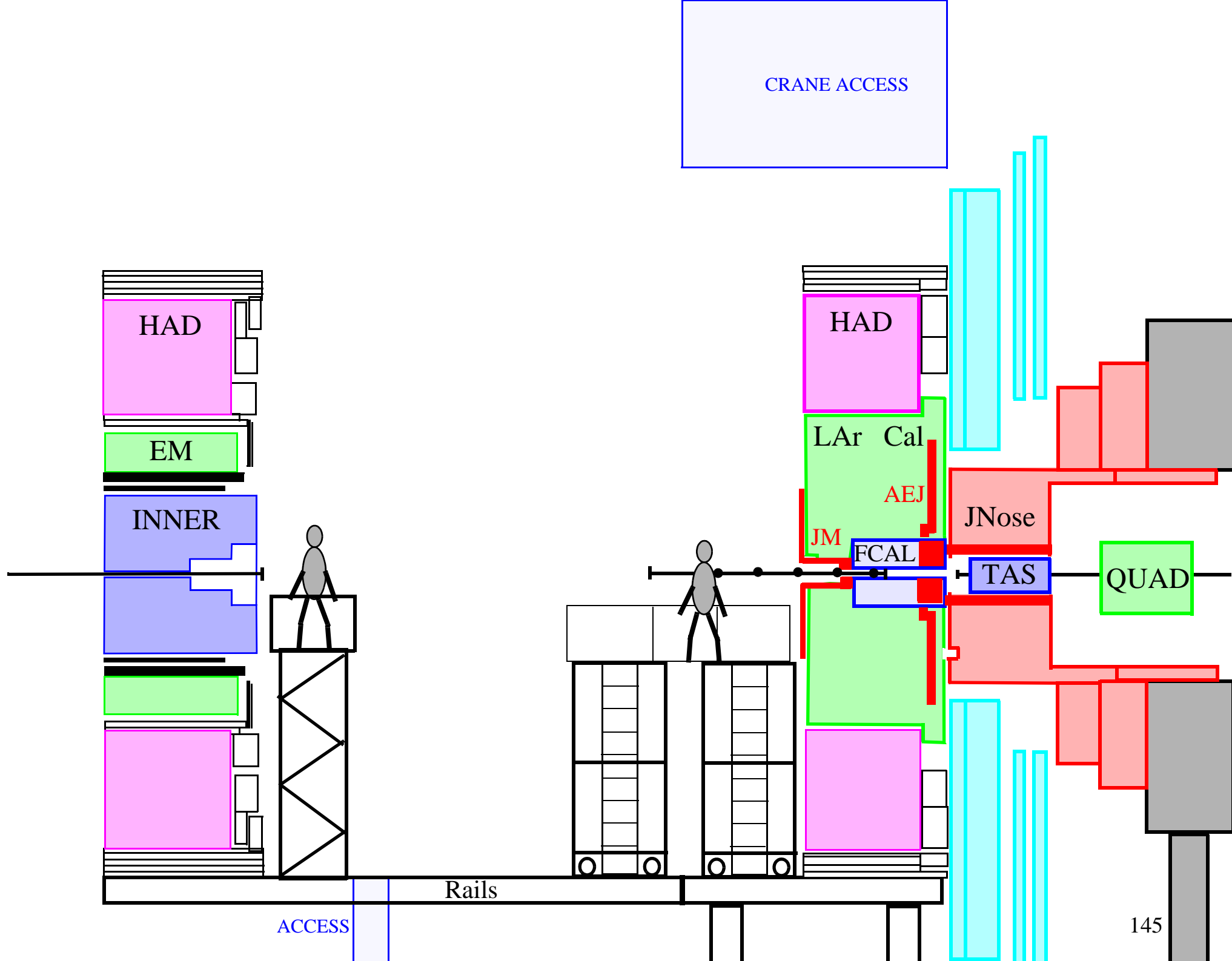

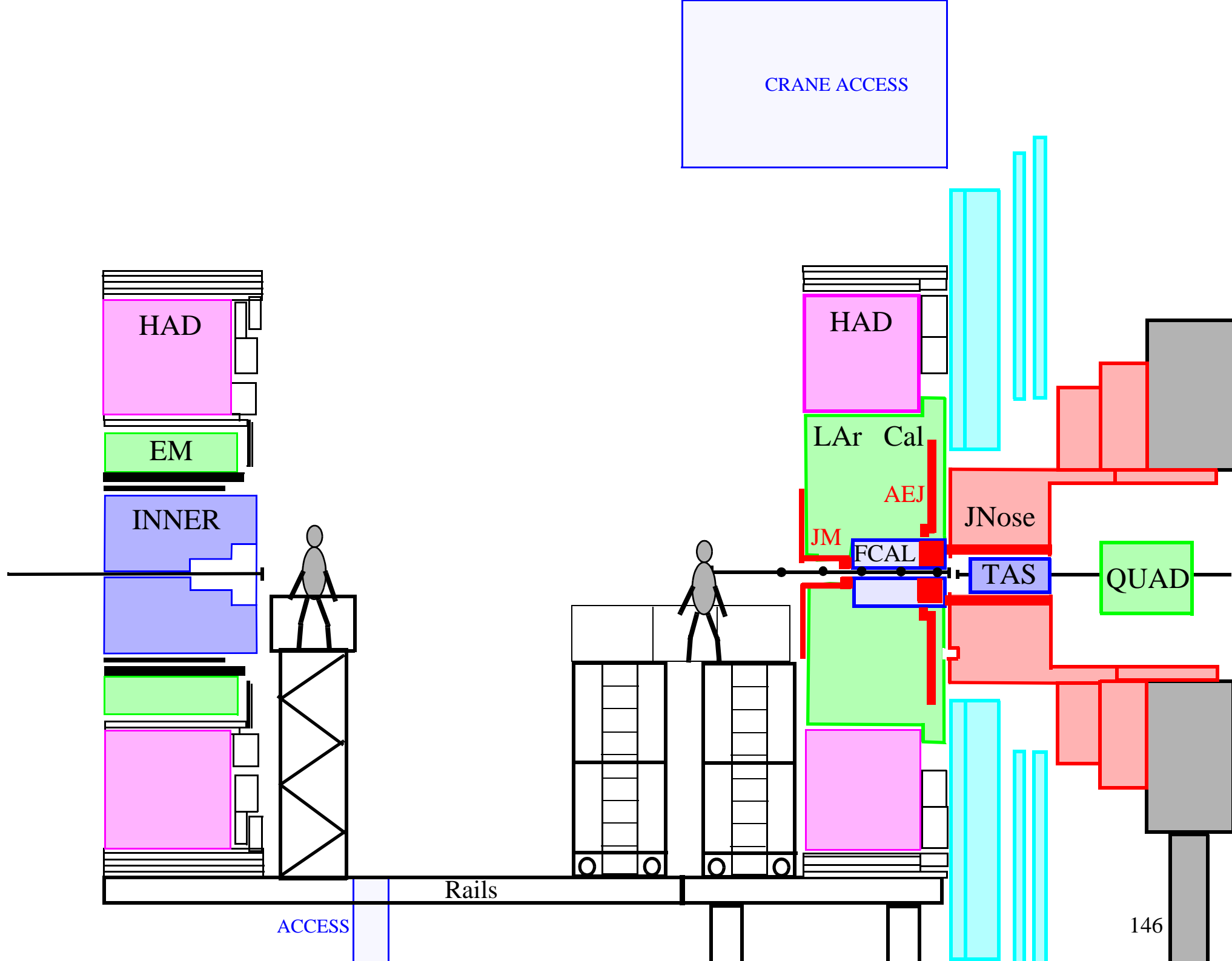

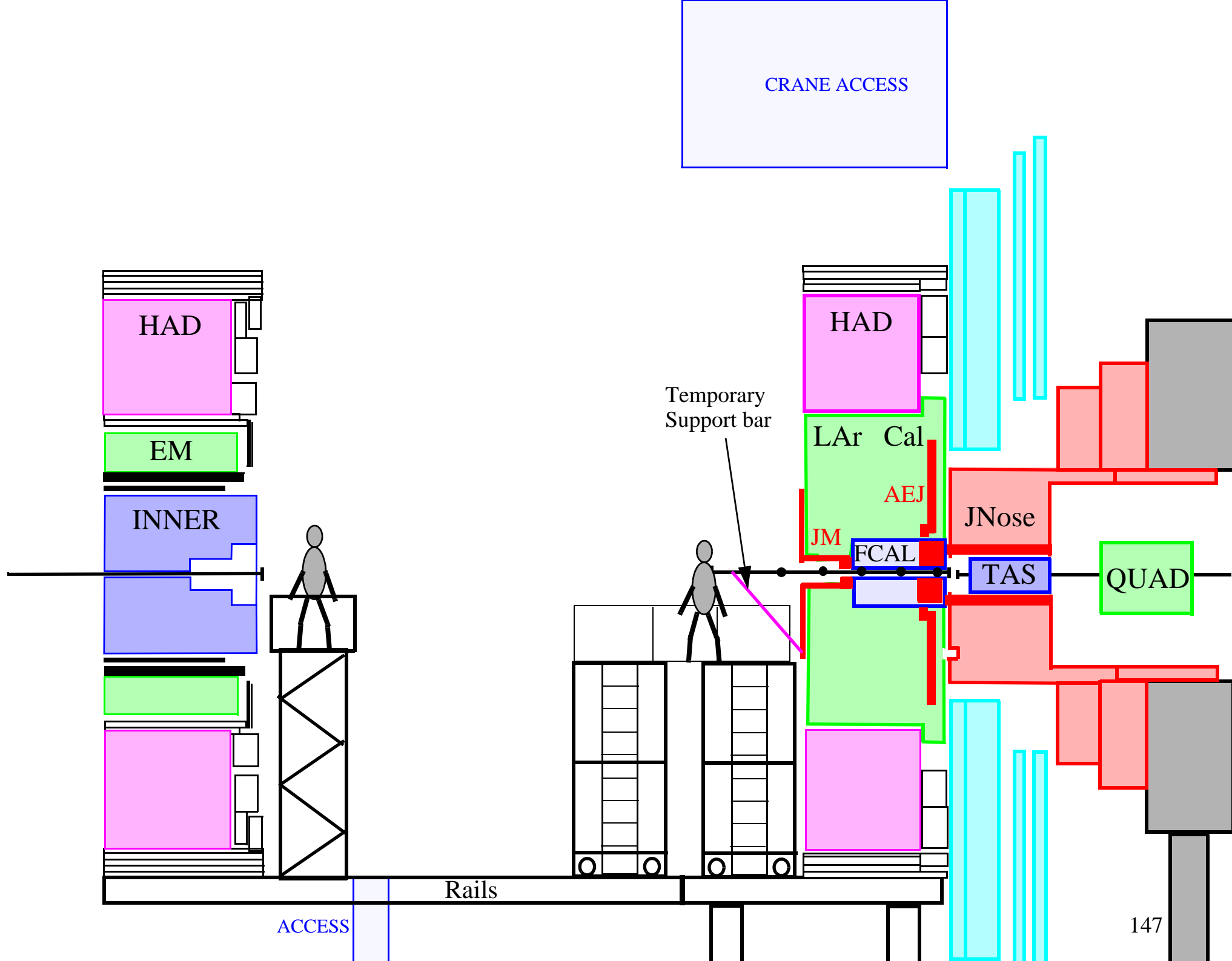

CRANE ACCESS

HAD

EM

INNER

Temporary Support bar

HAD

LAr Cal

AEJ

JM

FCAL

JNose

TAS

QUAD

Rails

ACCESS

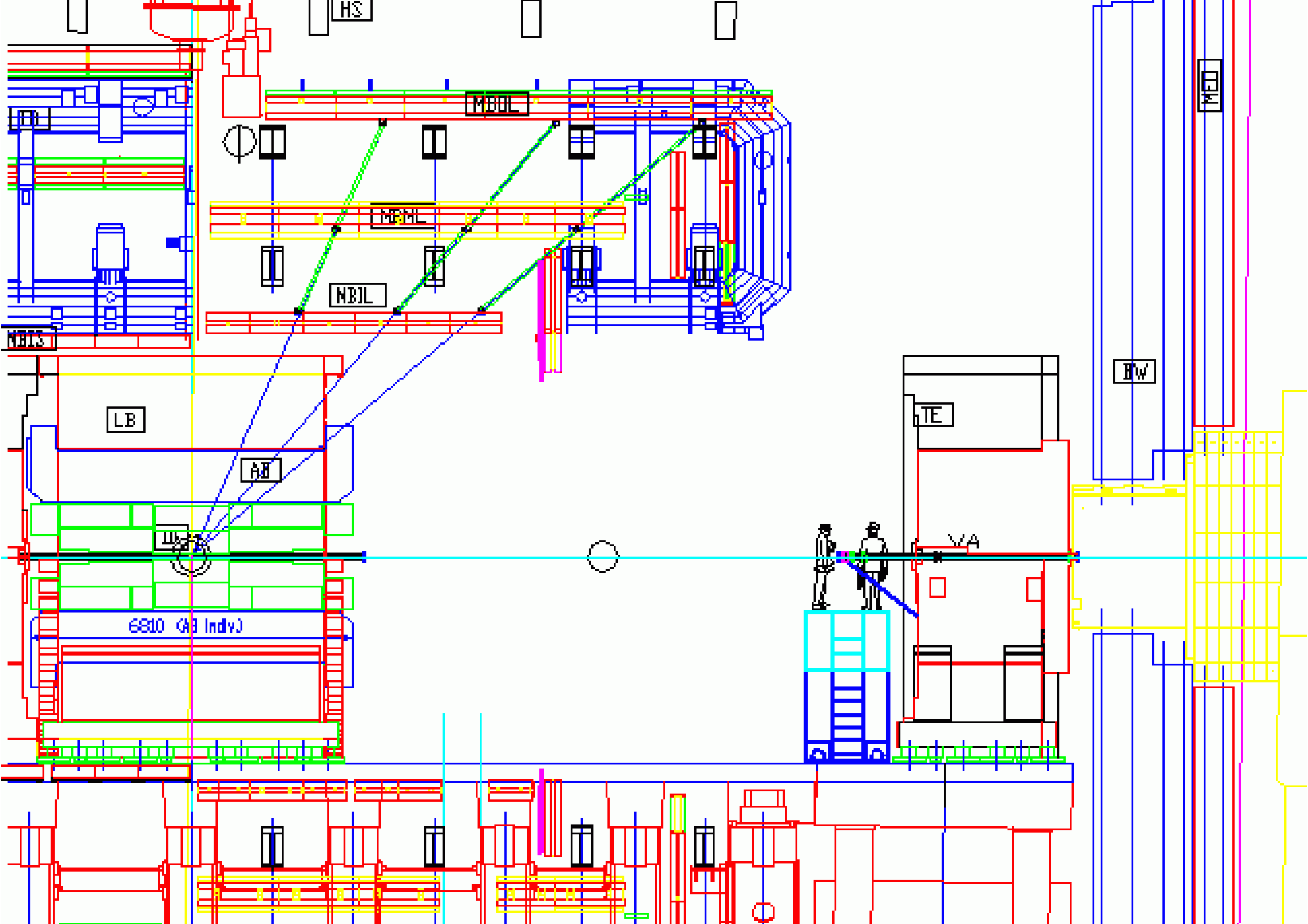

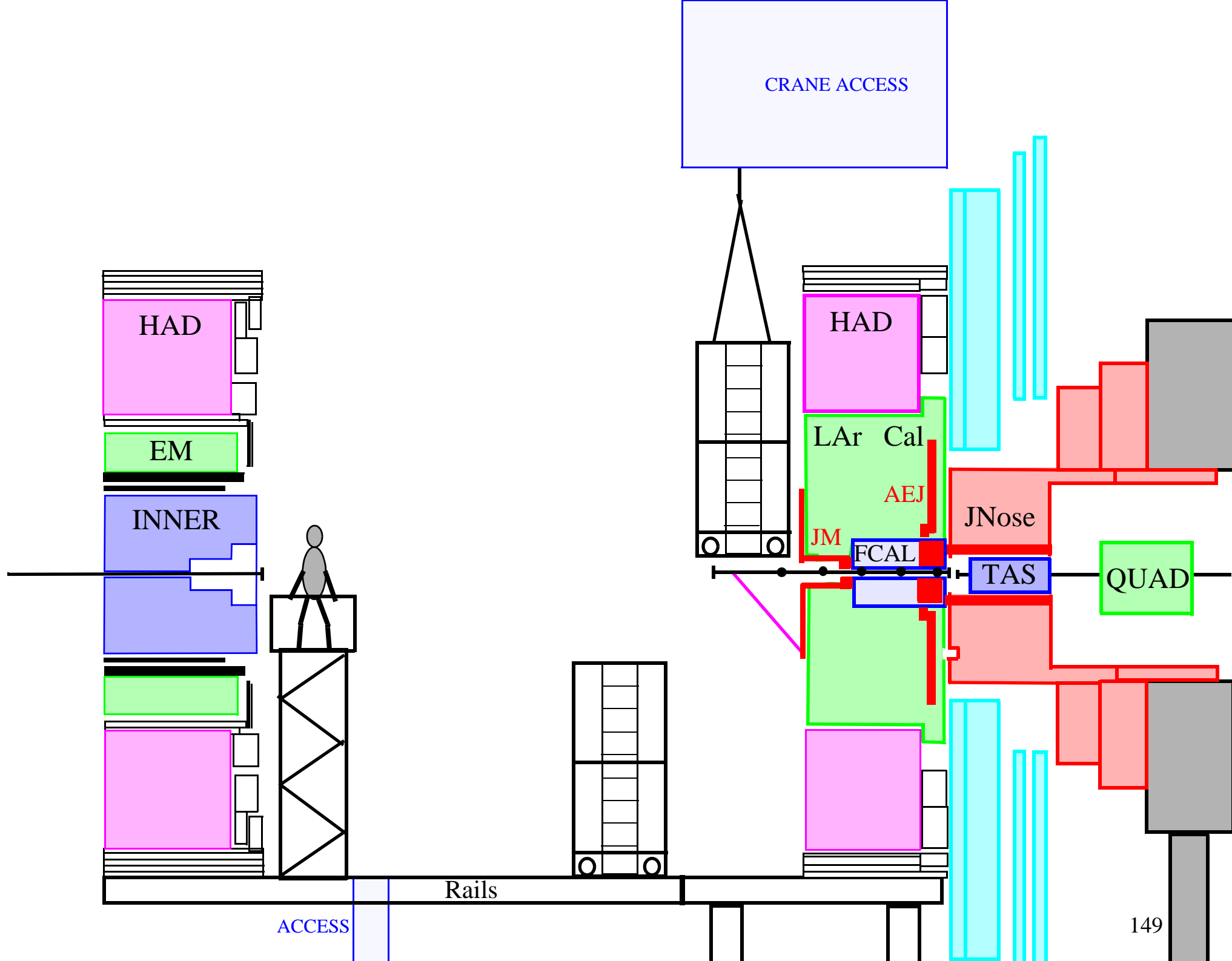

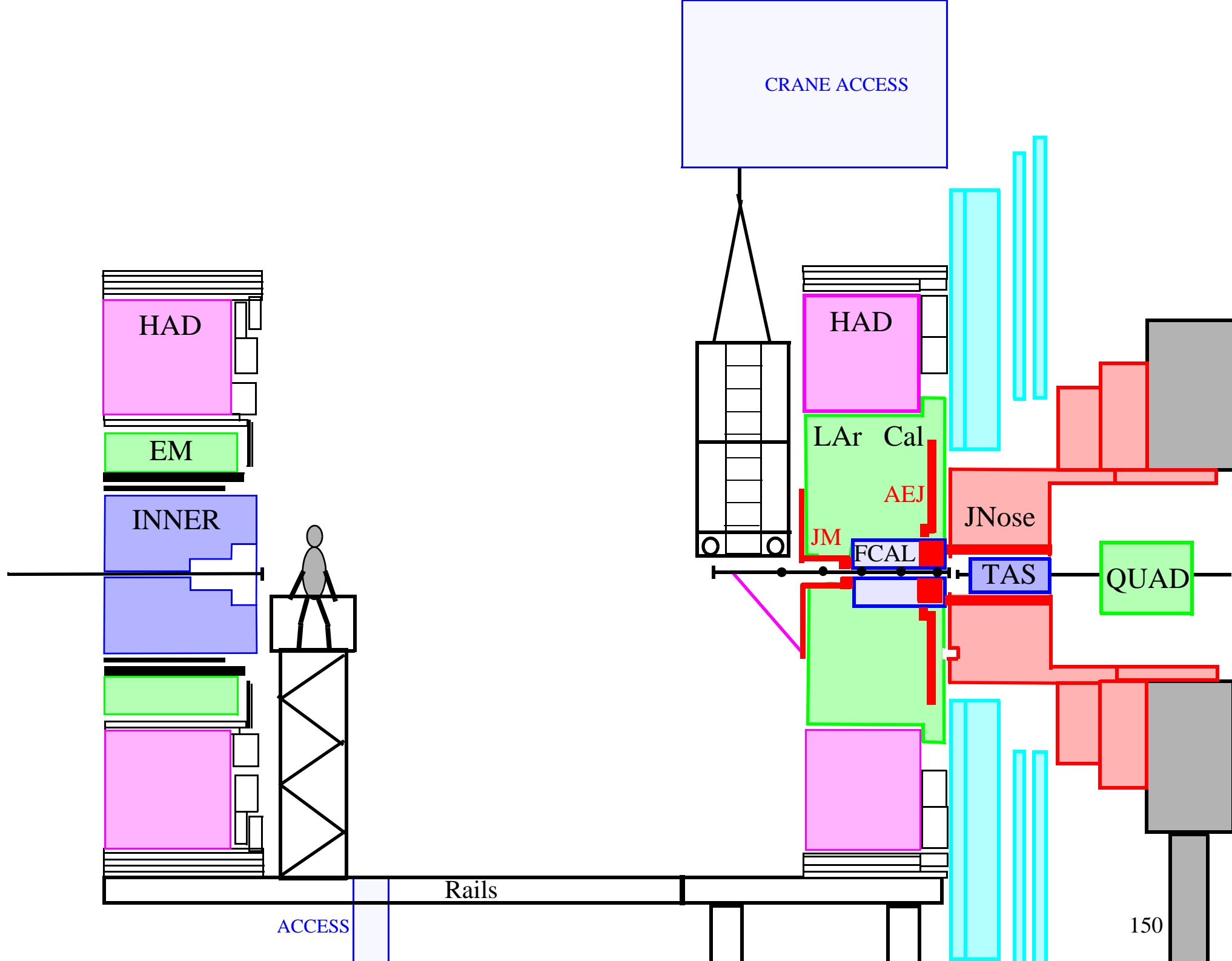

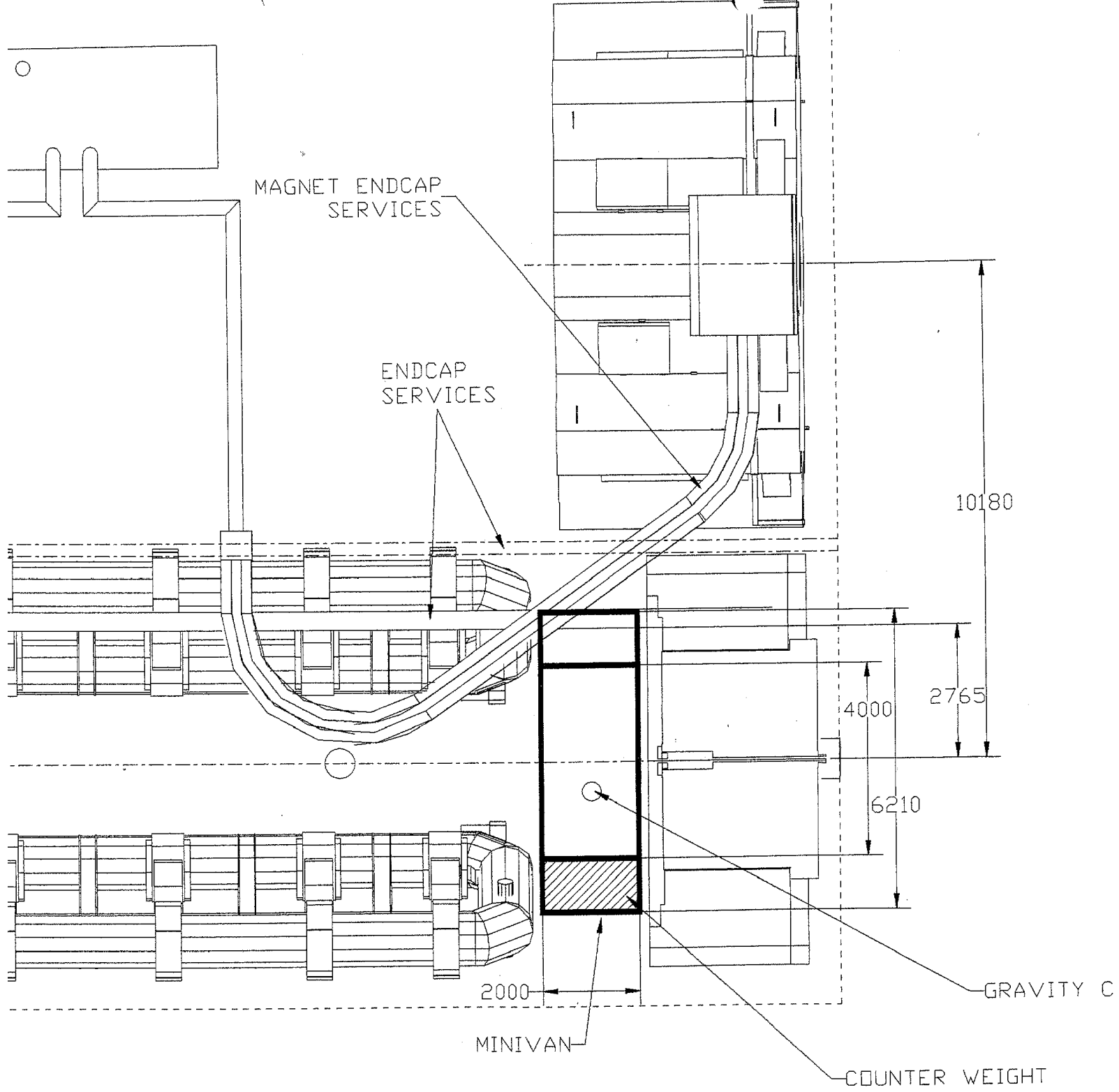

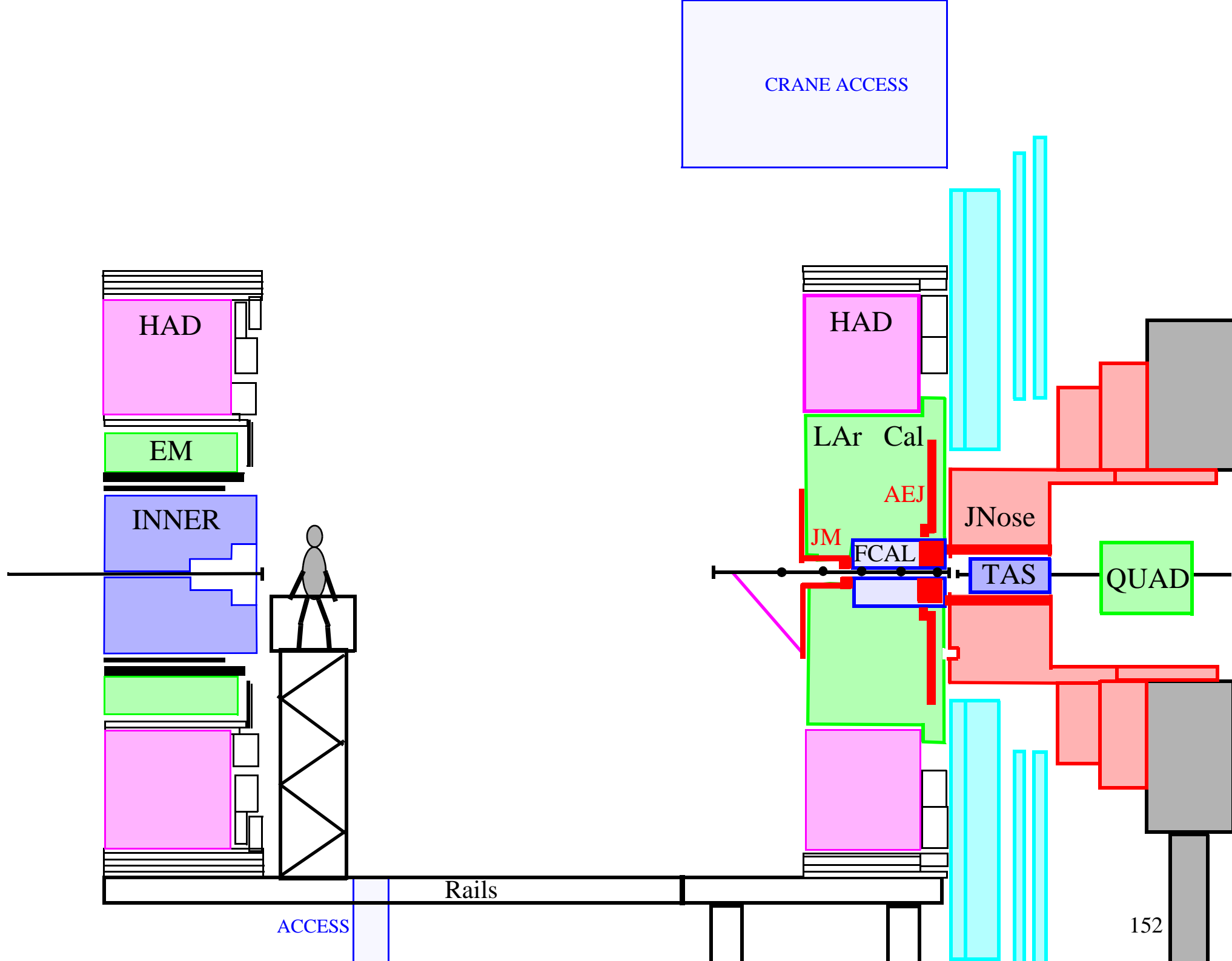

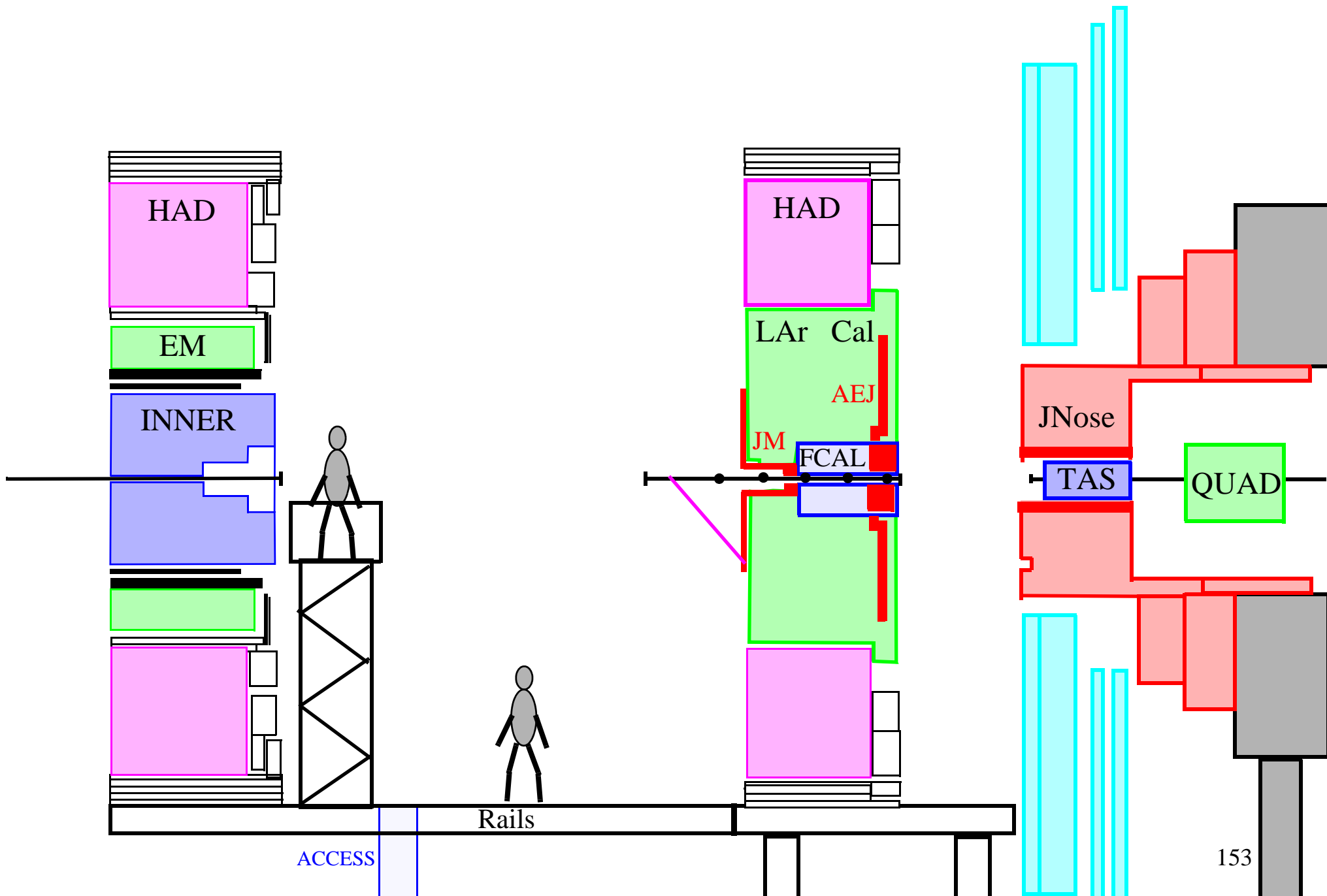

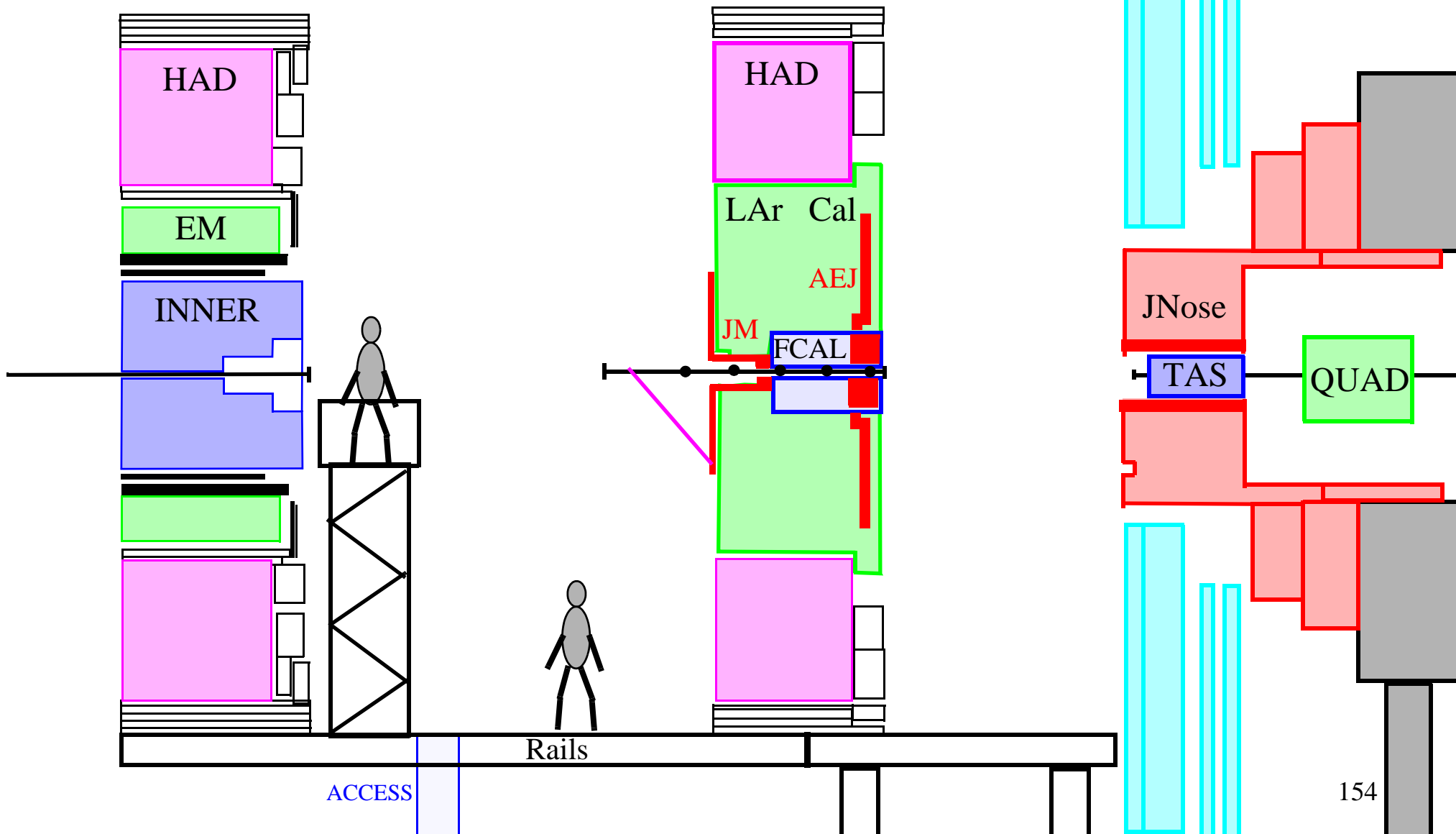

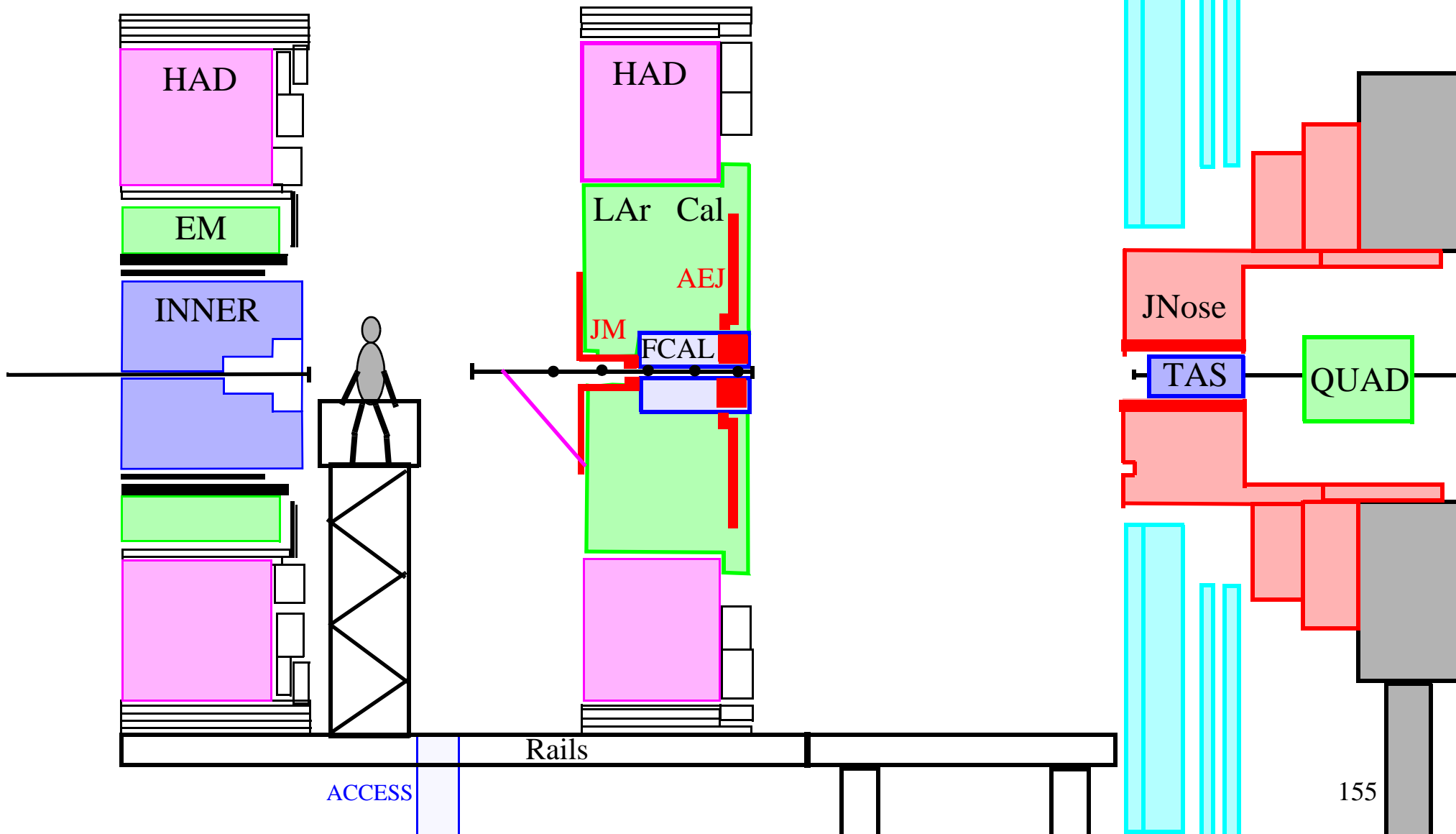

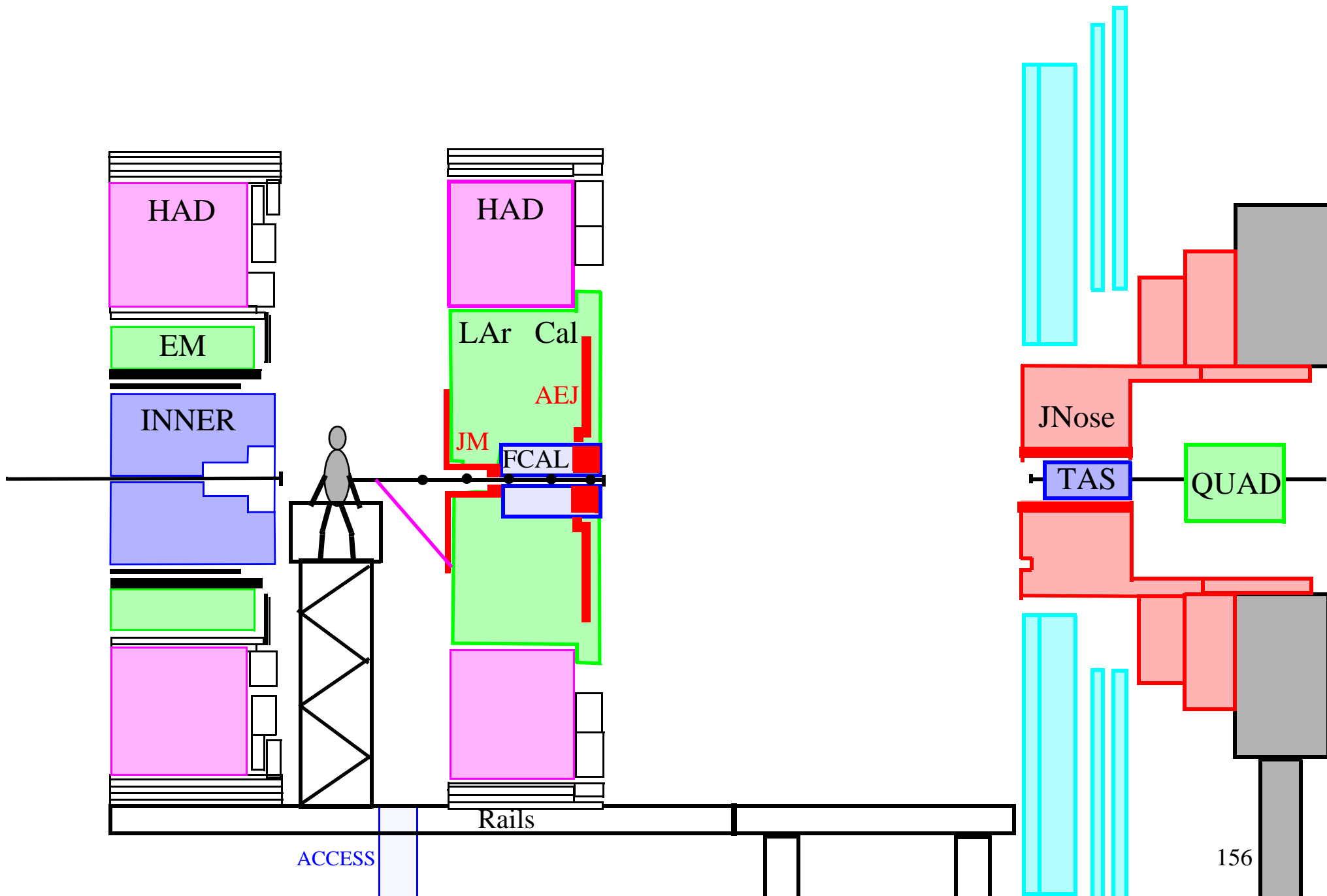

ACCESS

RAILS

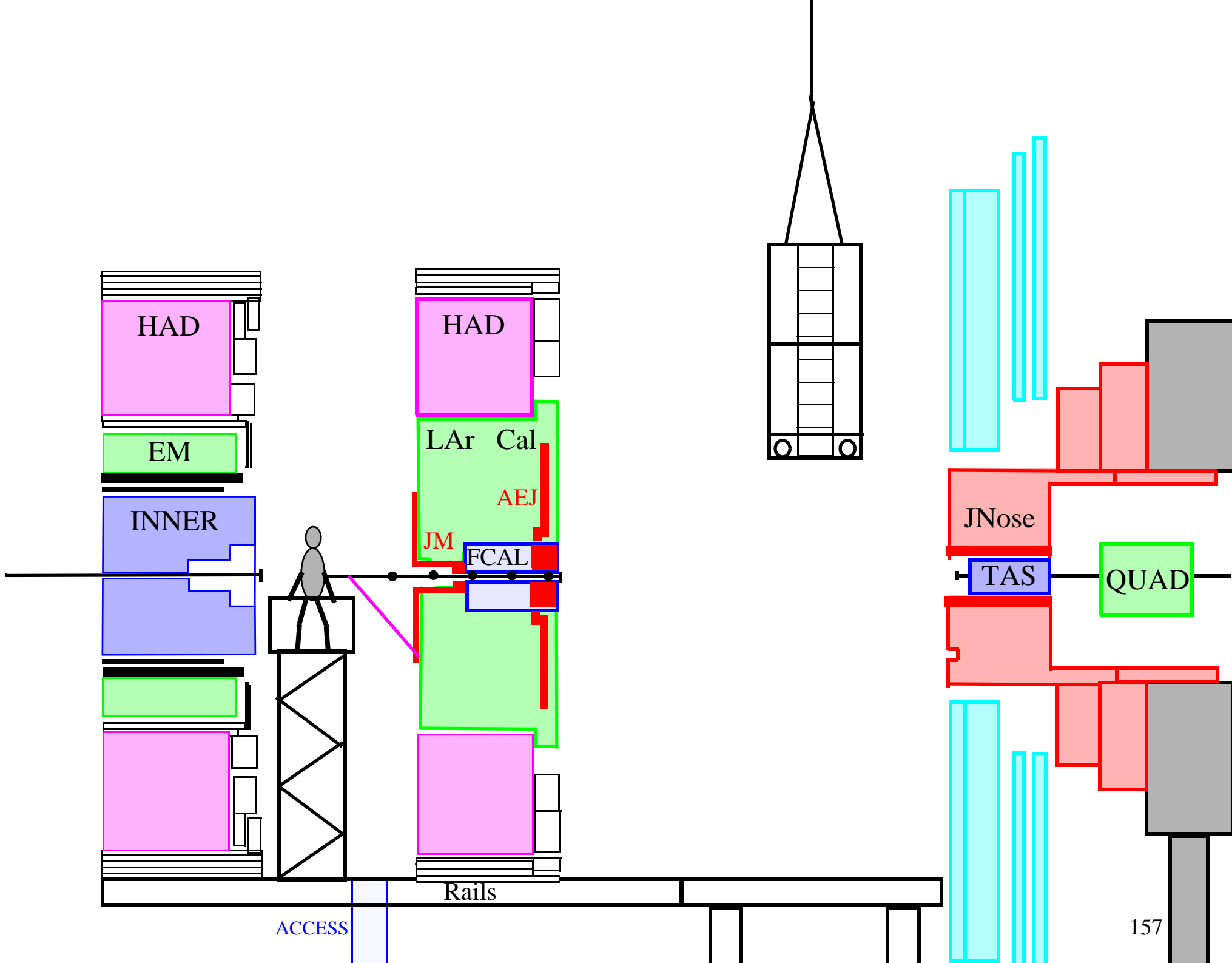

ACCESS

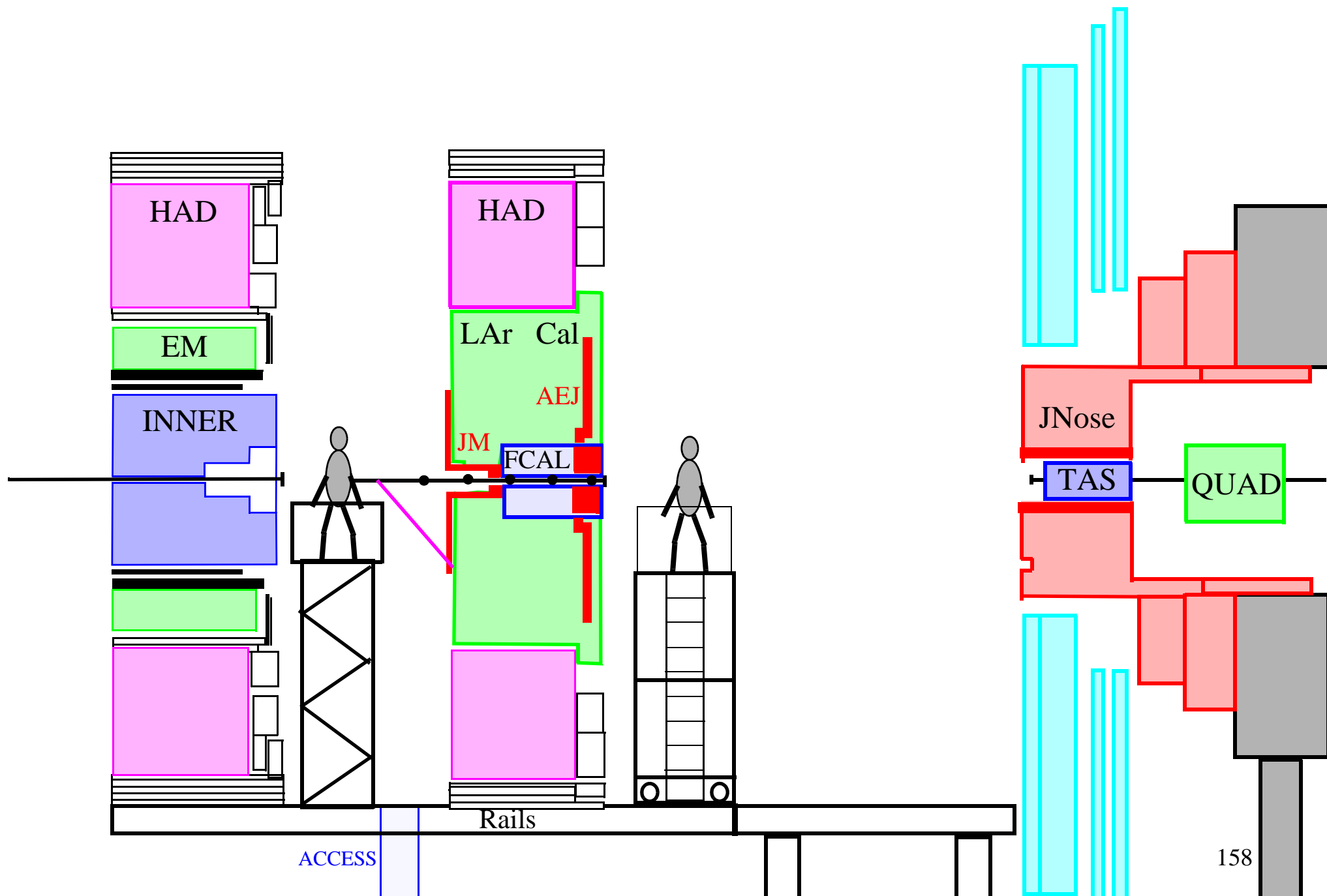

ACCESS

Rails

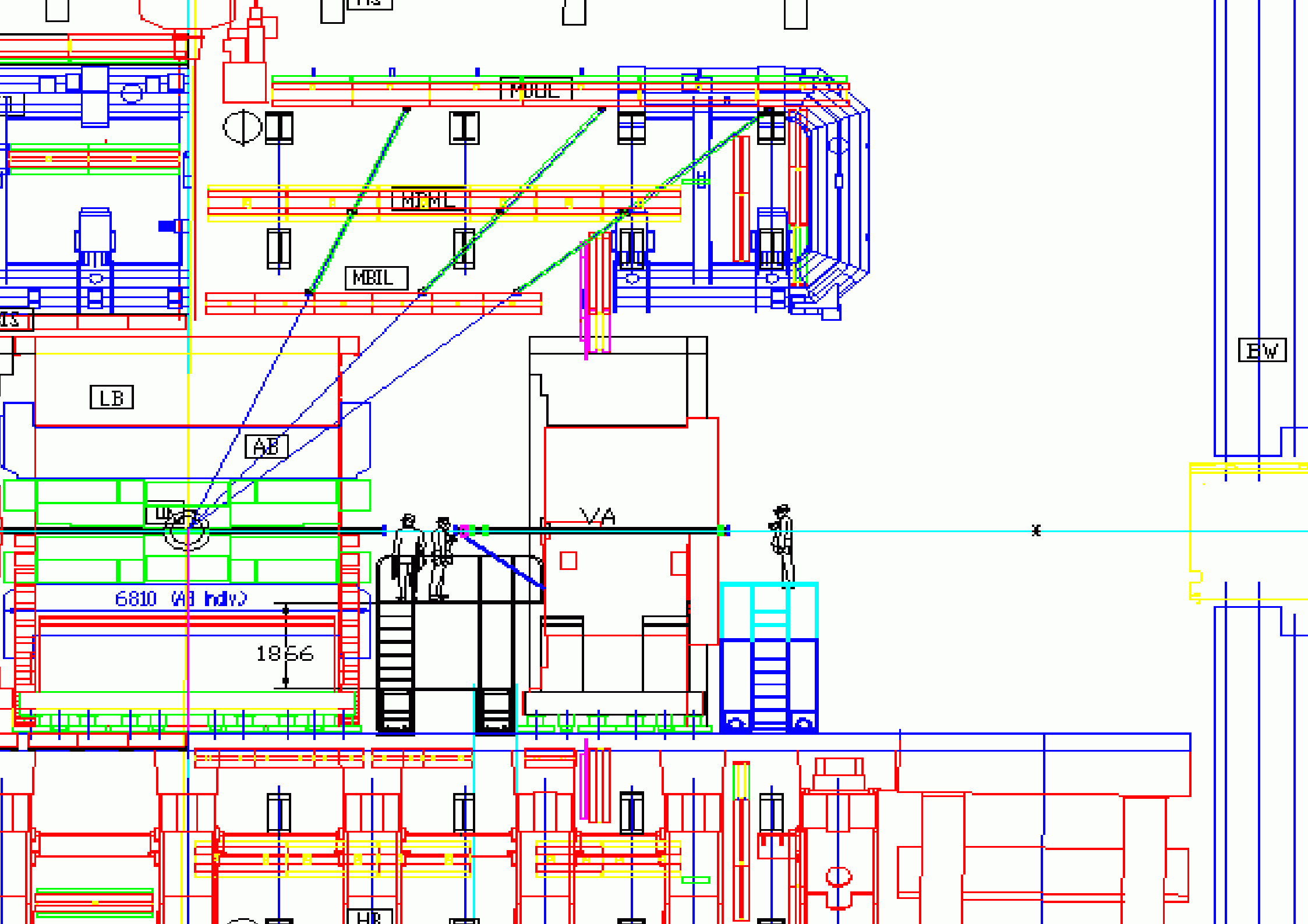

MBIL

MBIL

MBIL

LB

AB

VA

BW

6810 (AB Indiv)

1856

*

HR

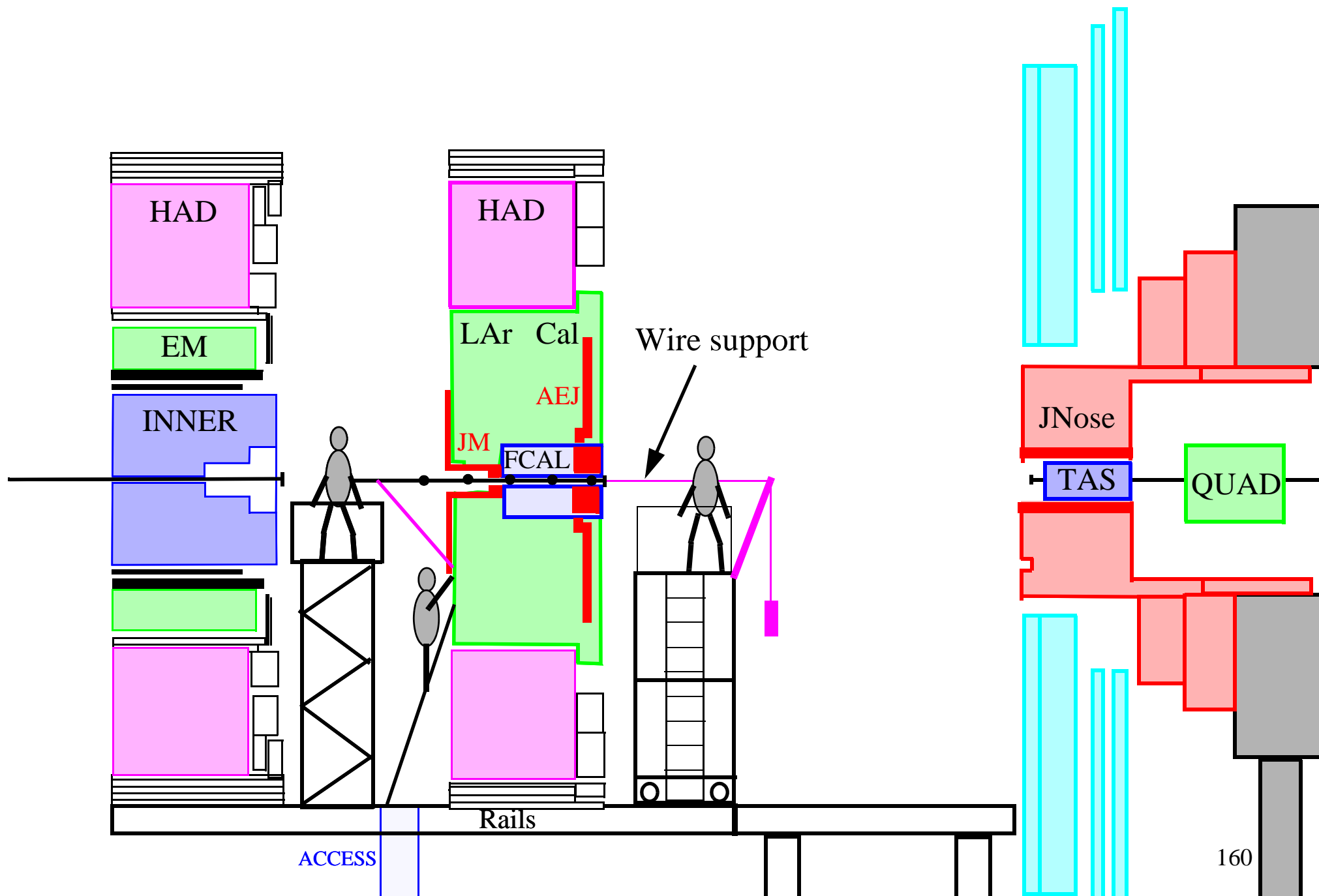

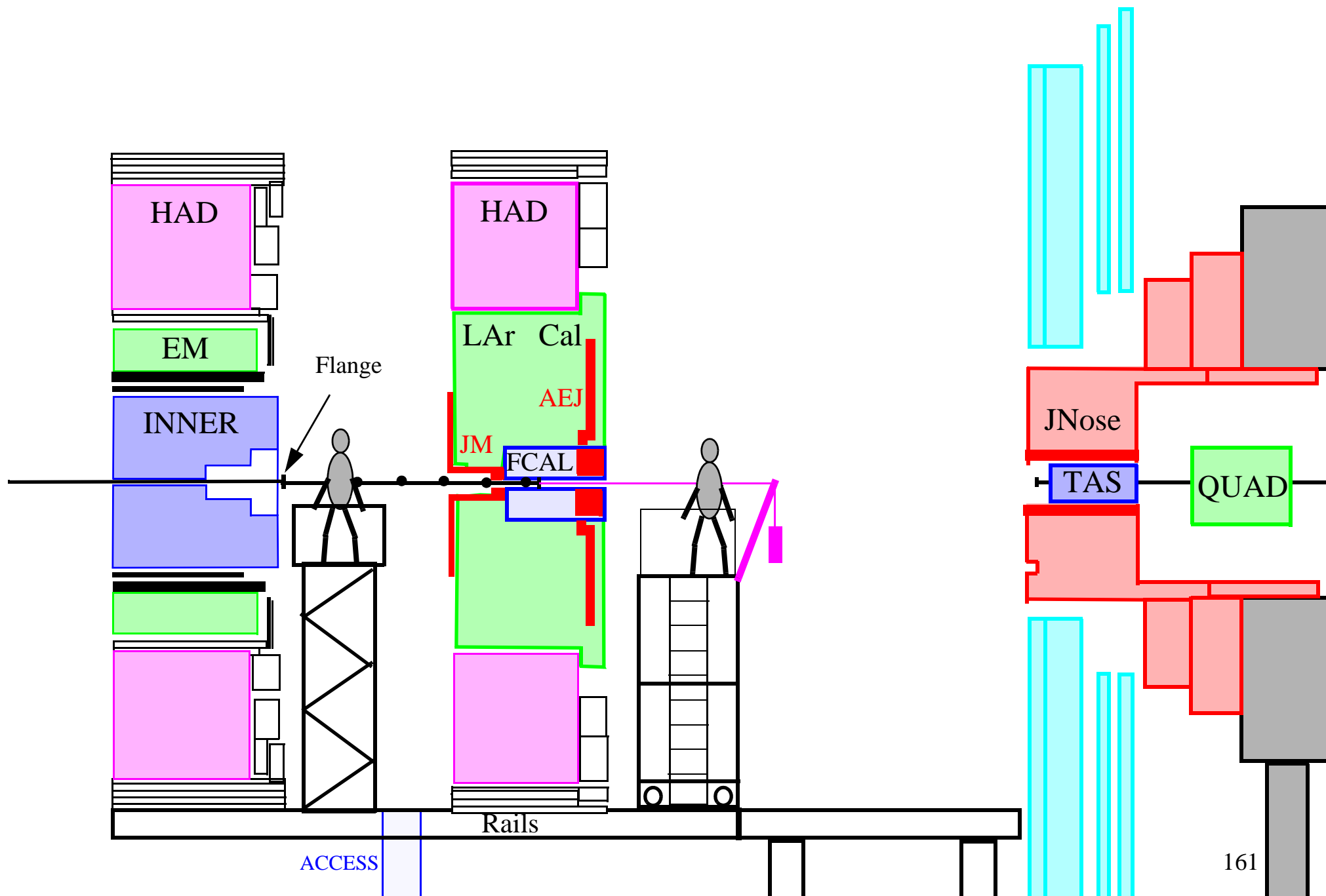

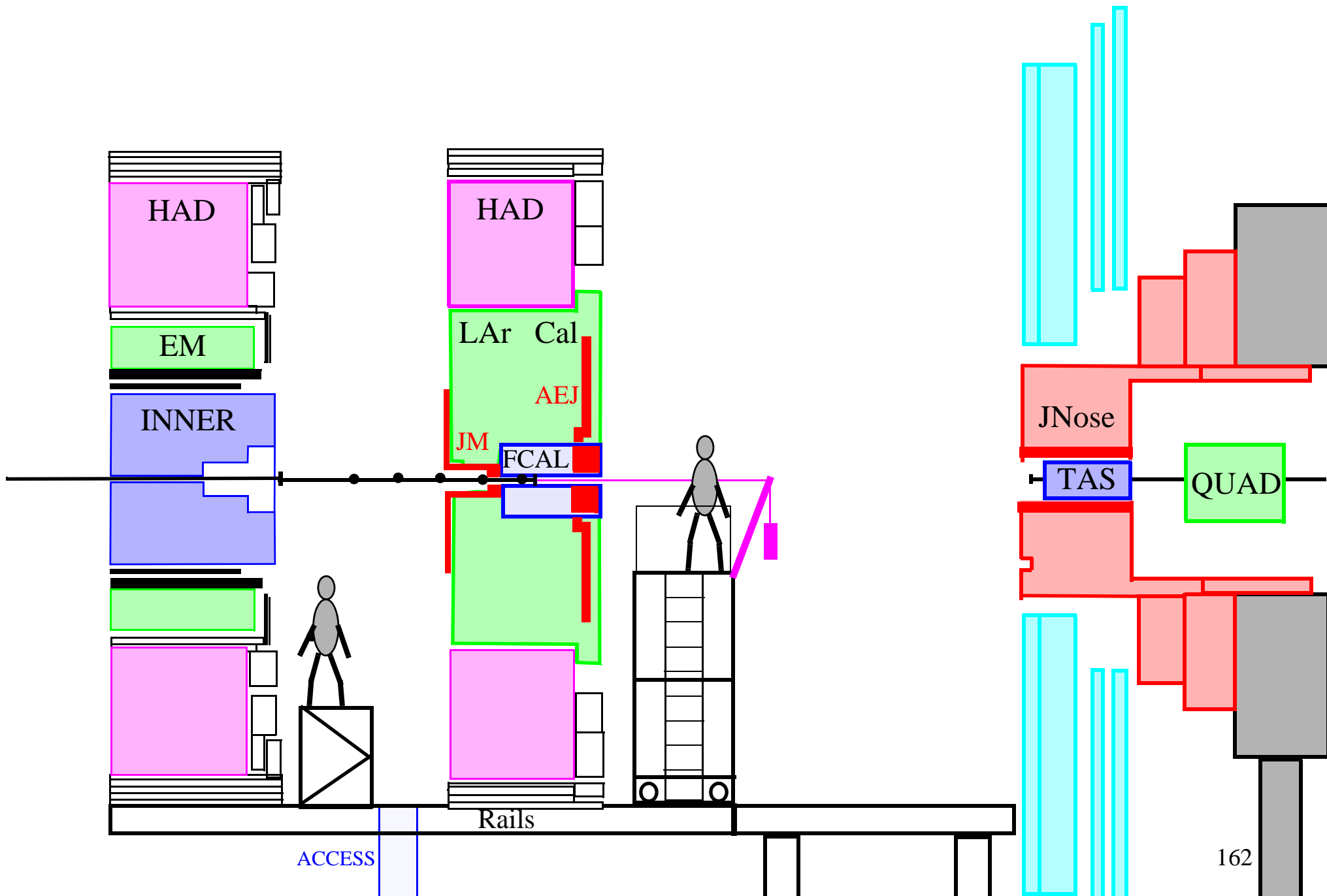

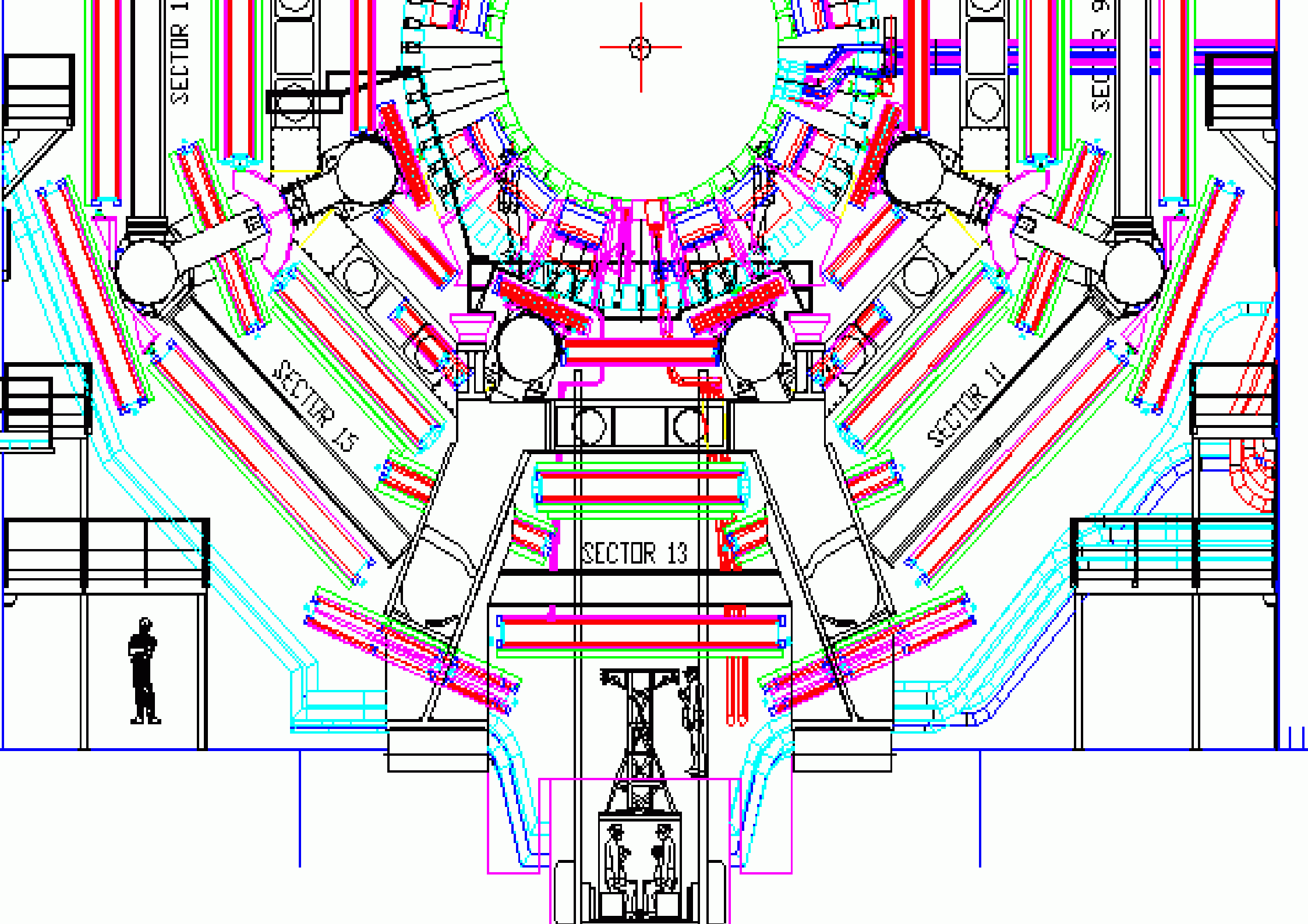

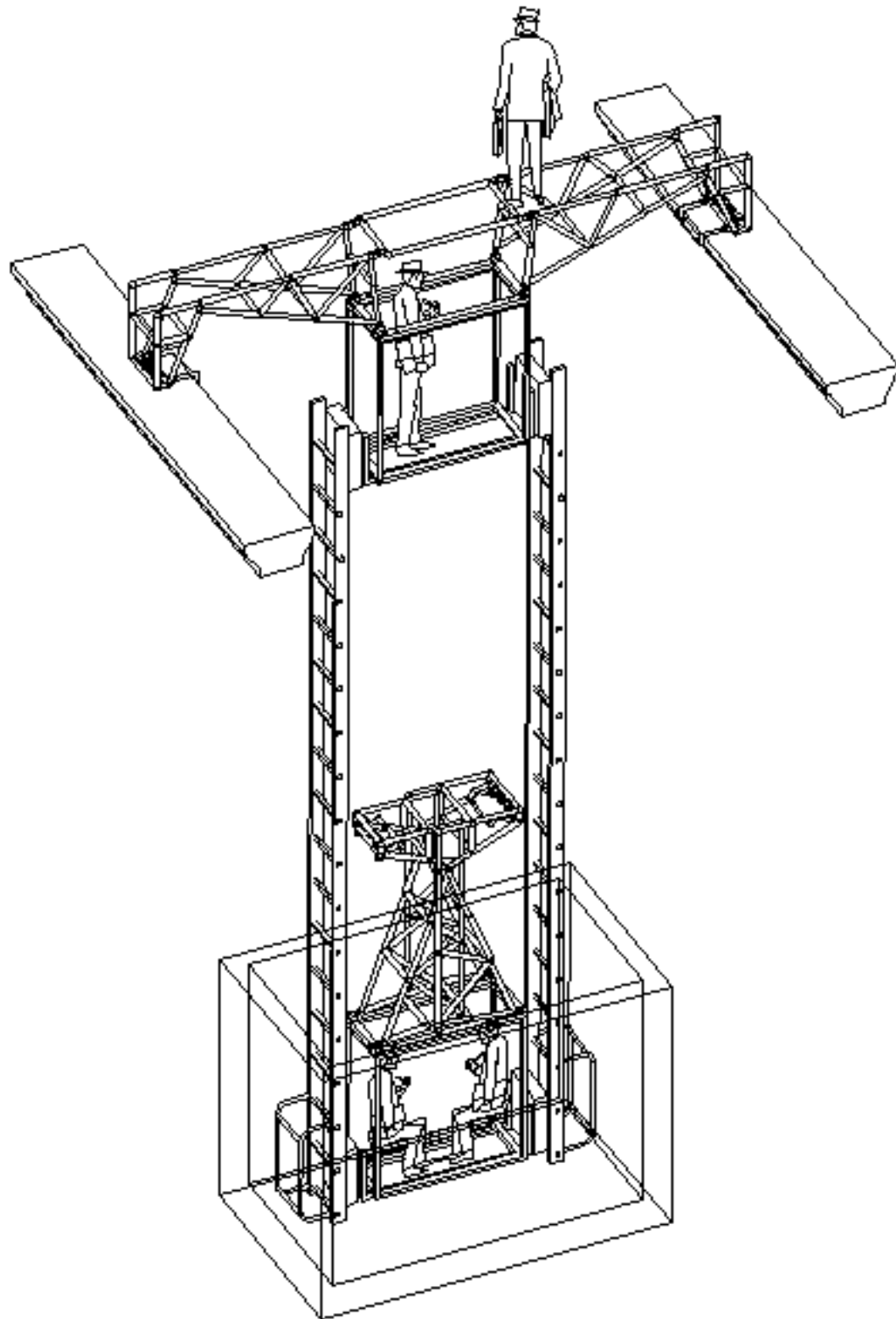

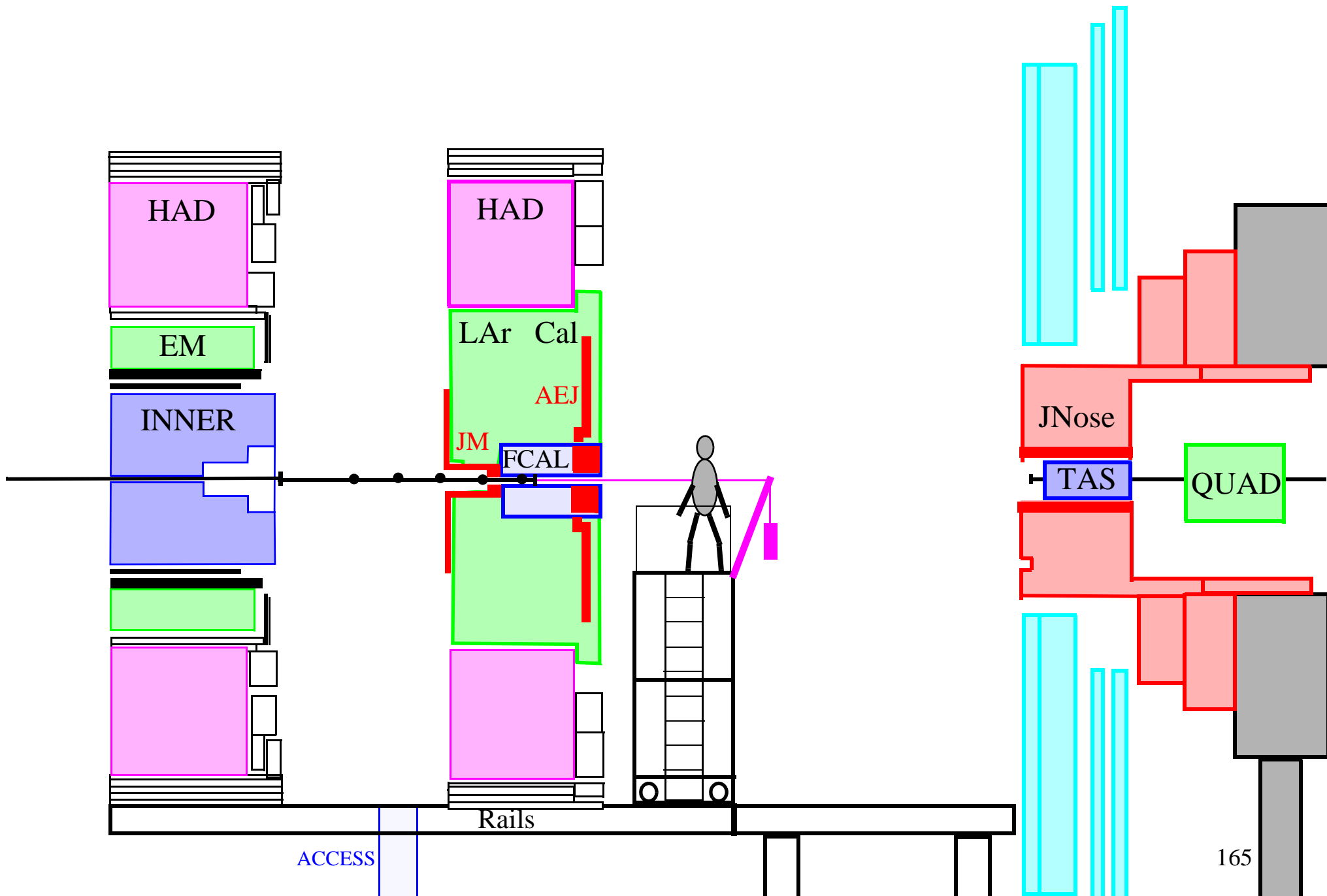

ACCESS

RAILS

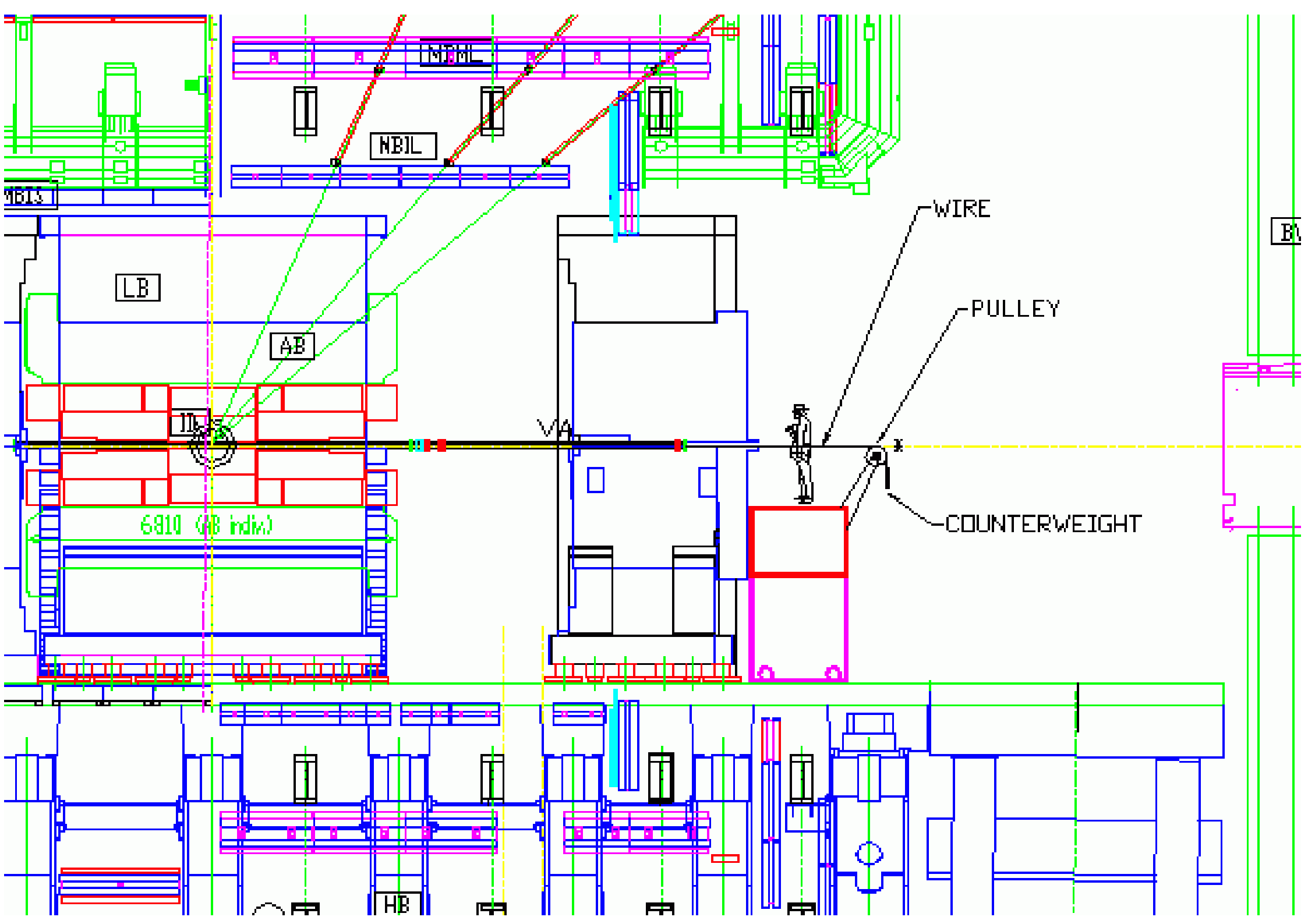

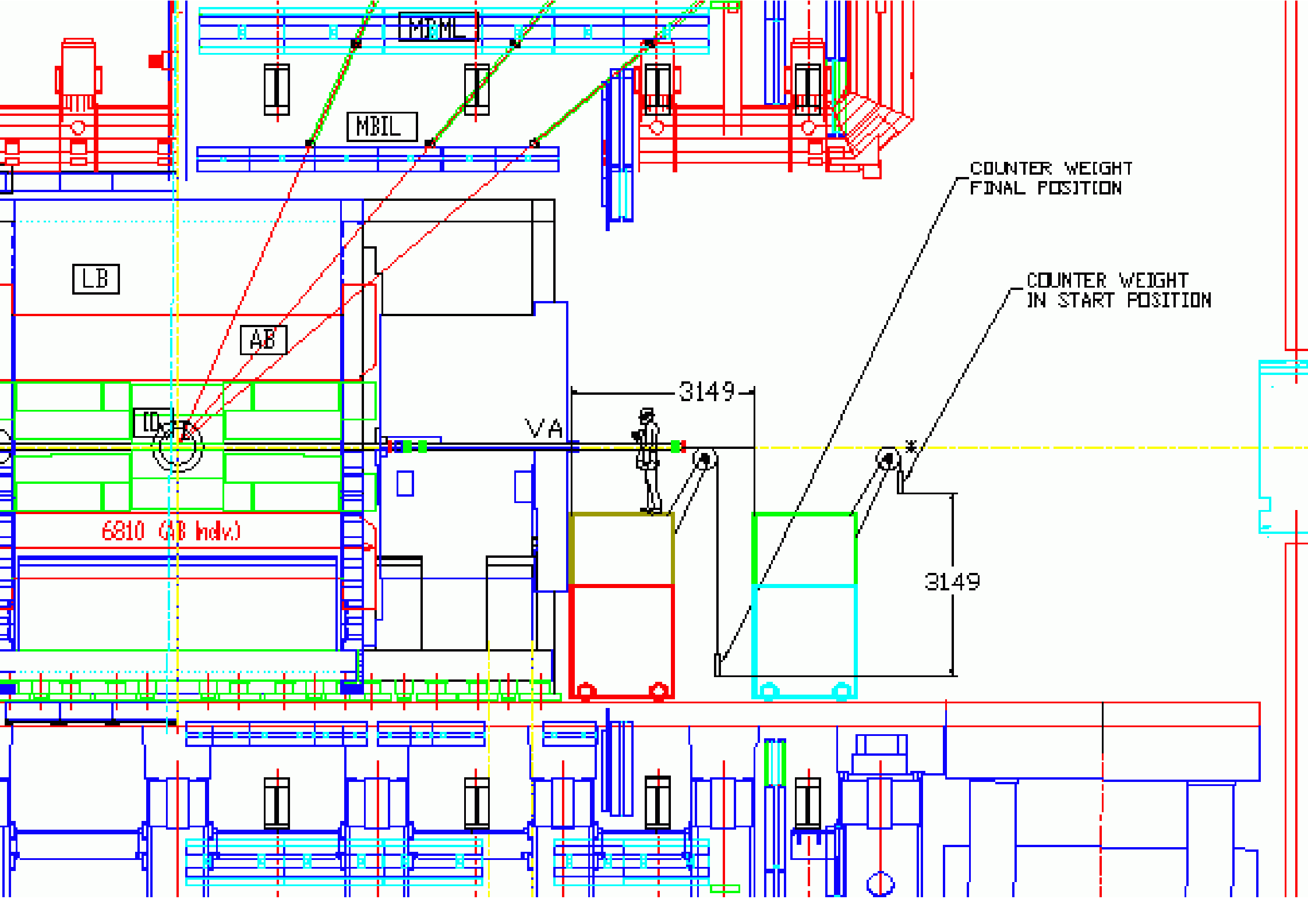

LB

AB

MBML

MBML

MBIL

3149

VA

6810 (AB incl.)

3149

COUNTER WEIGHT
FINAL POSITION

COUNTER WEIGHT
IN START POSITION

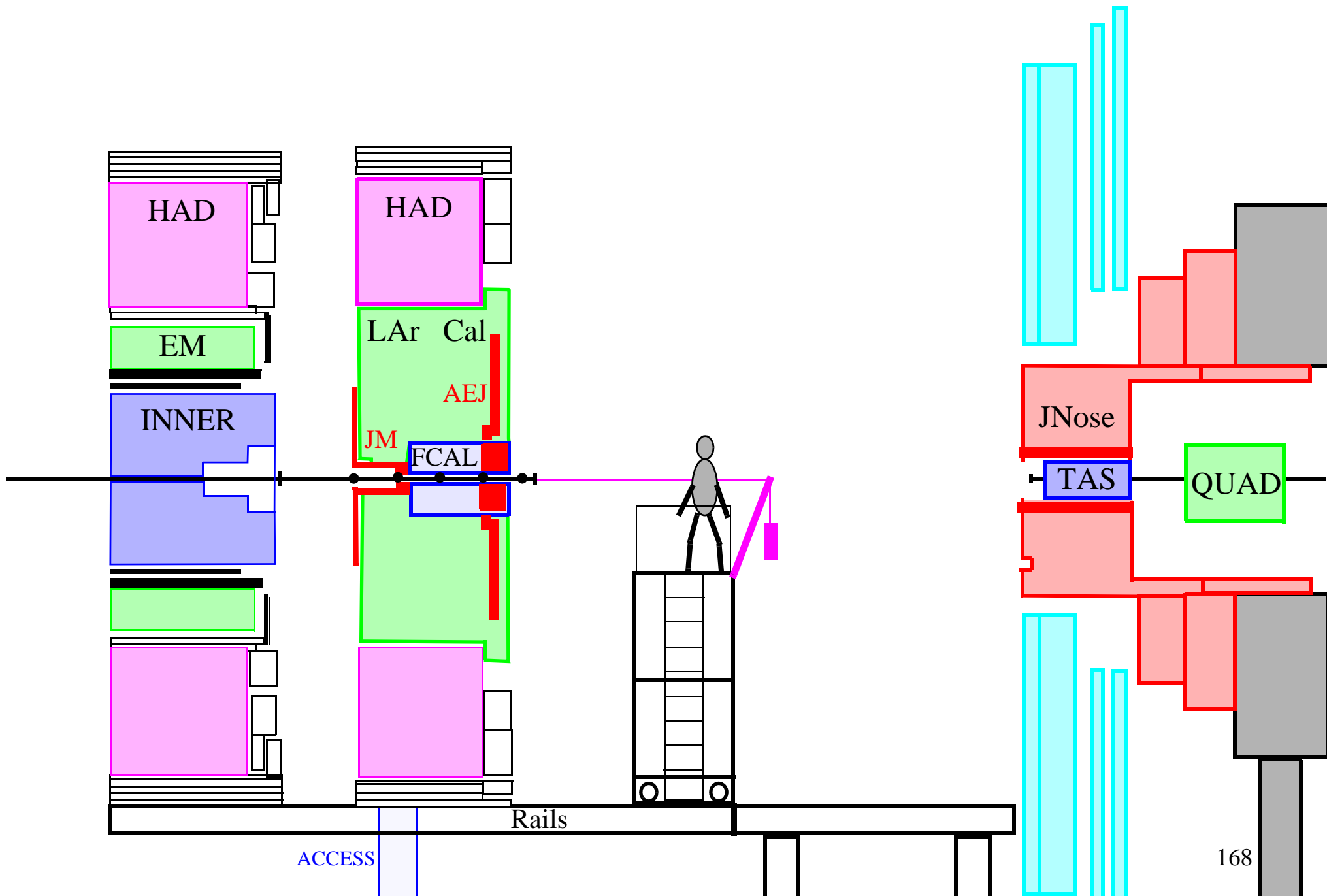

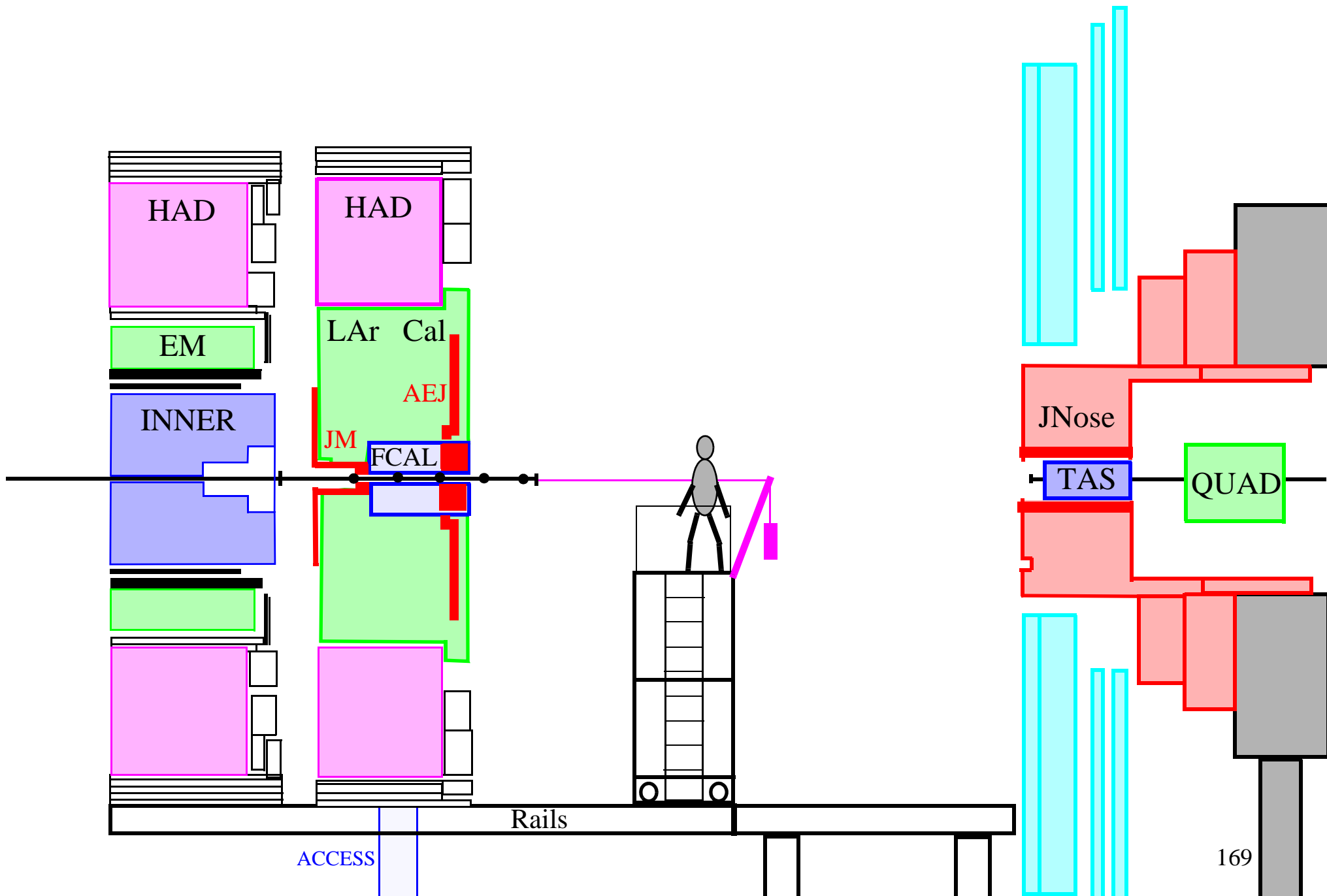

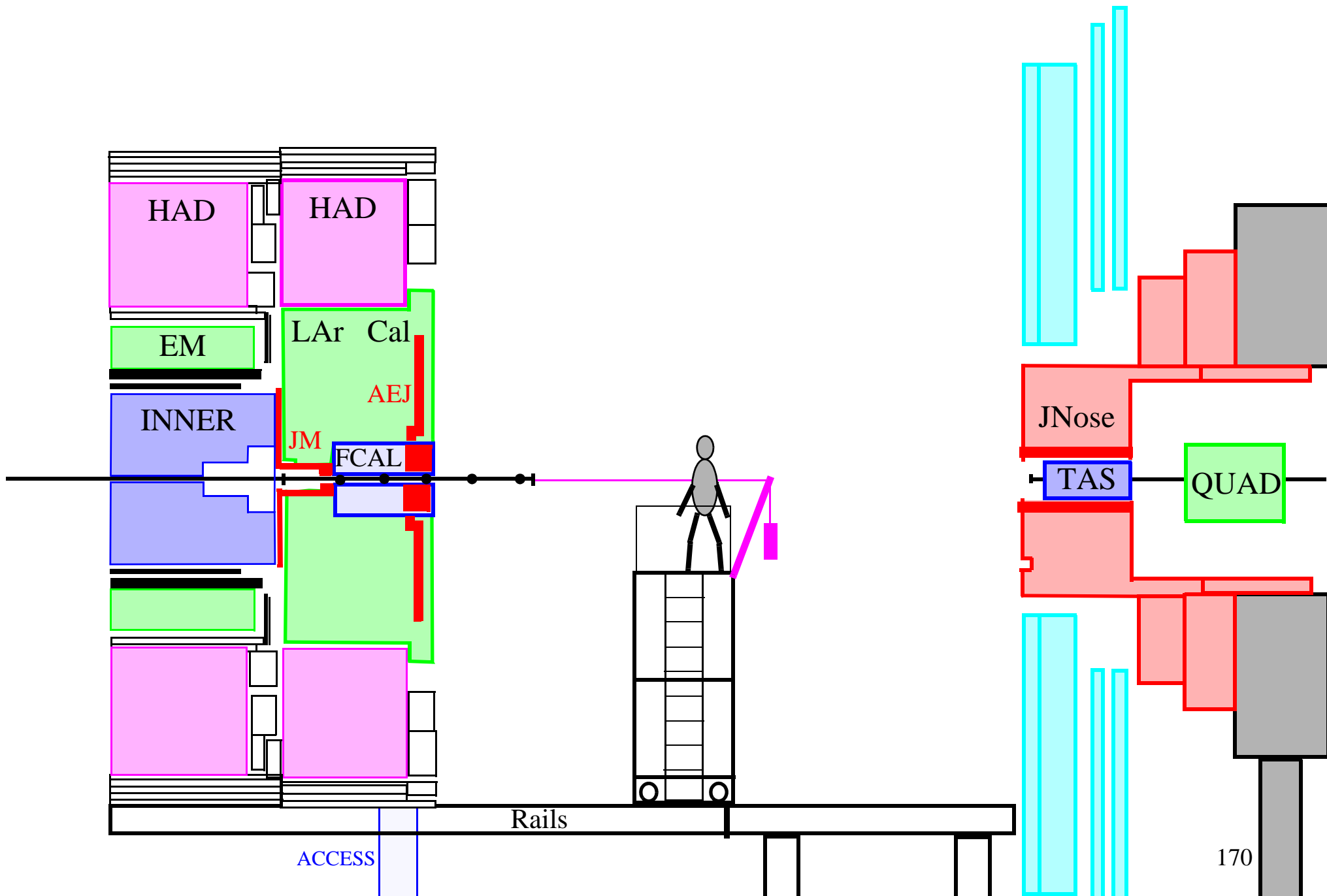

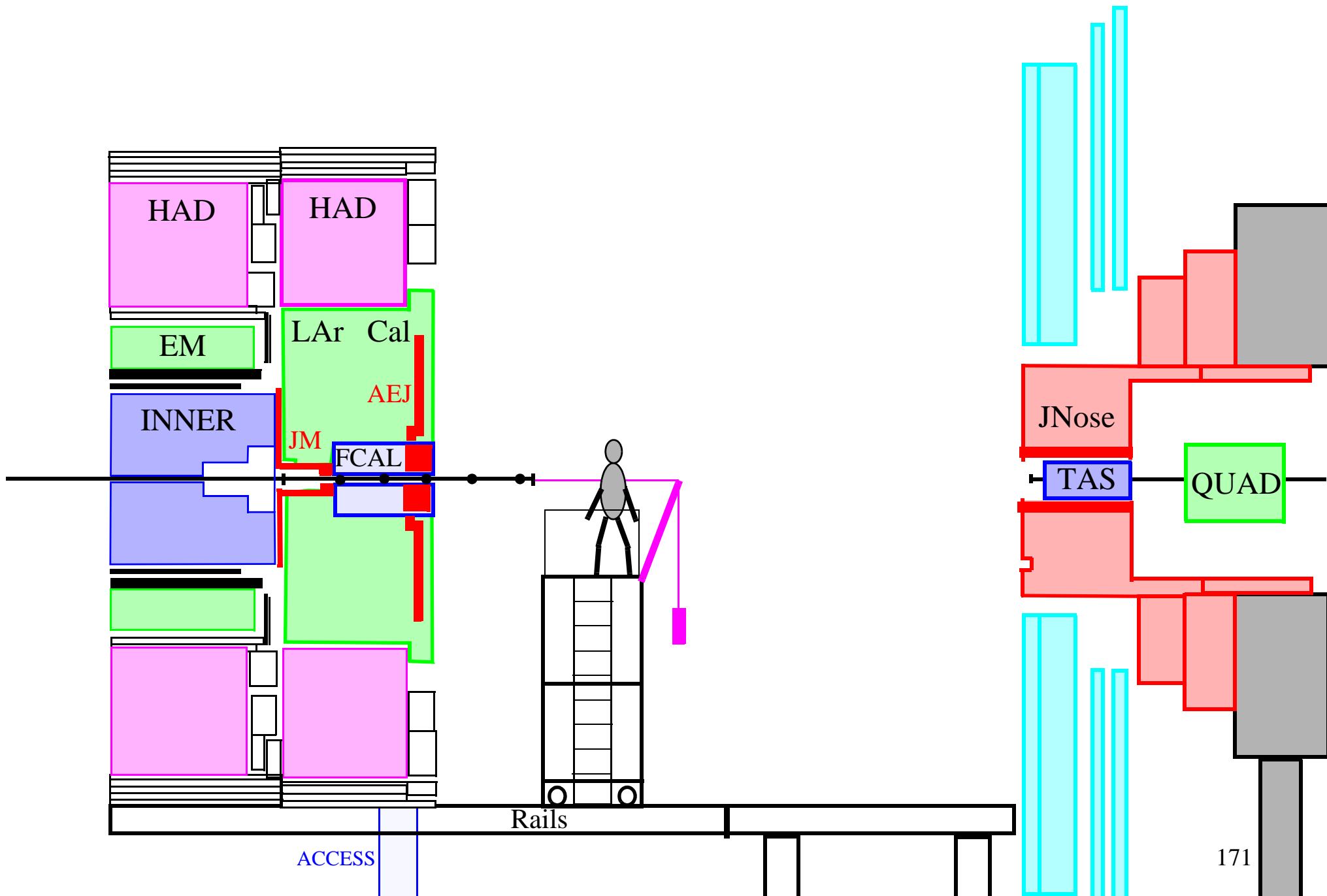

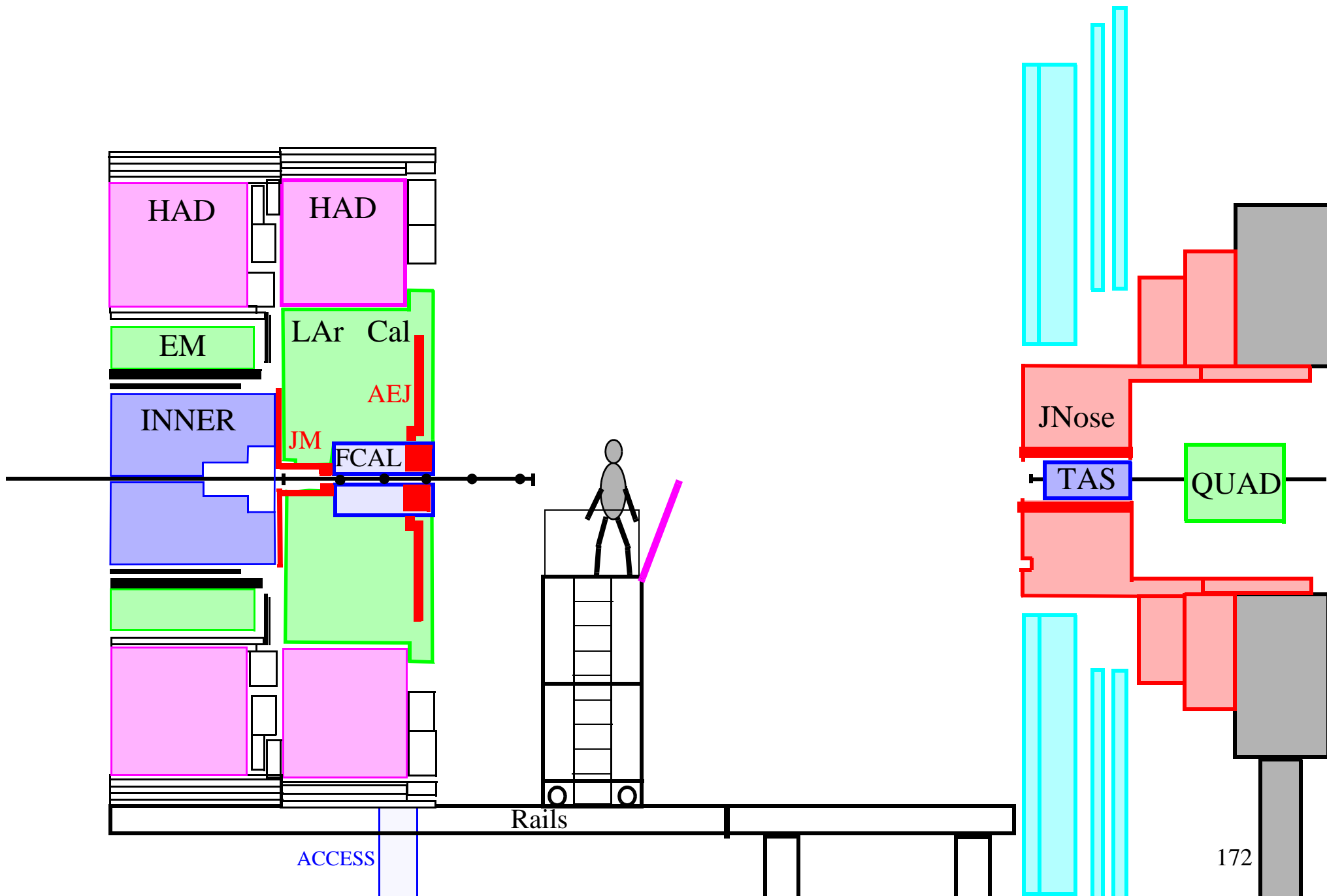

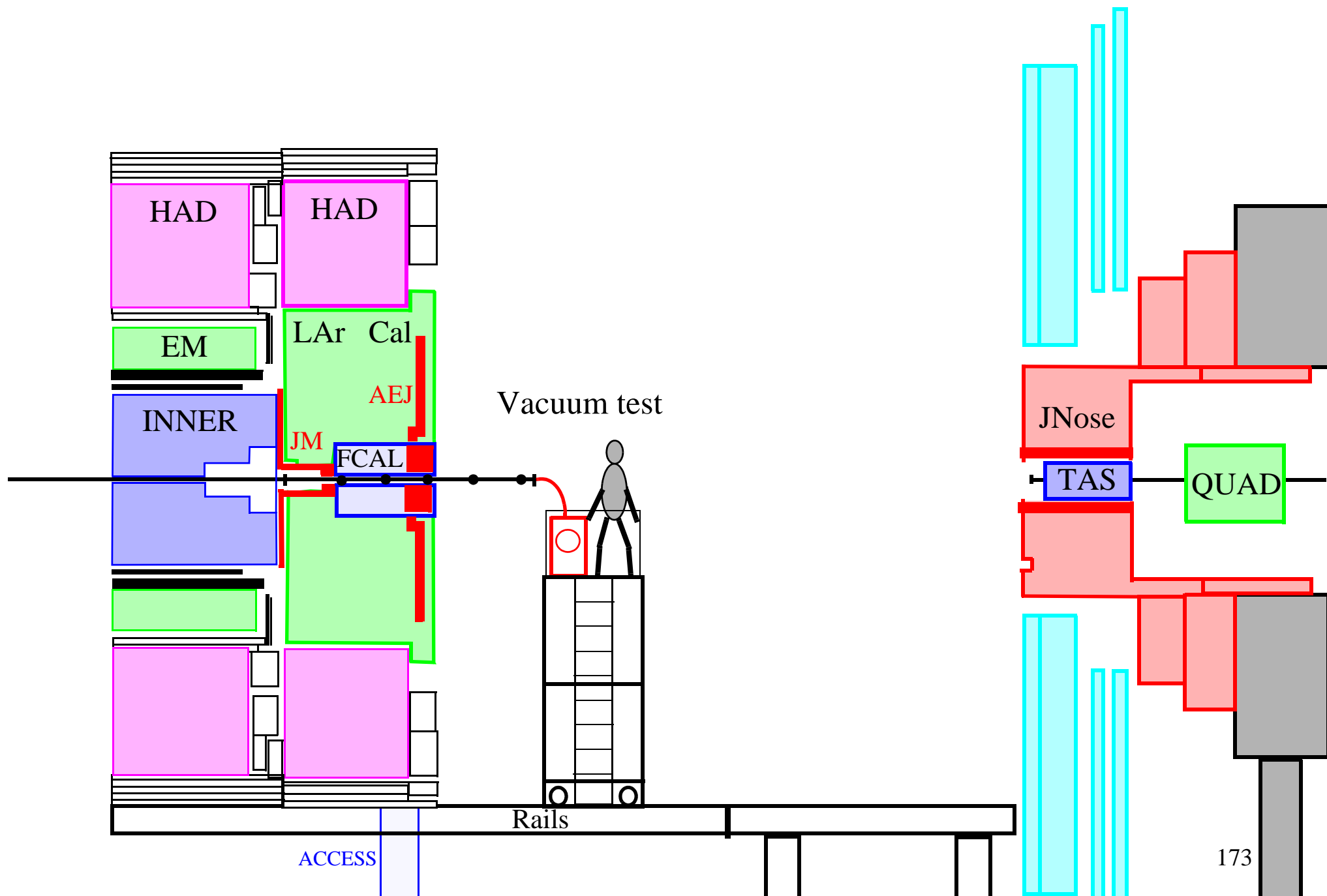

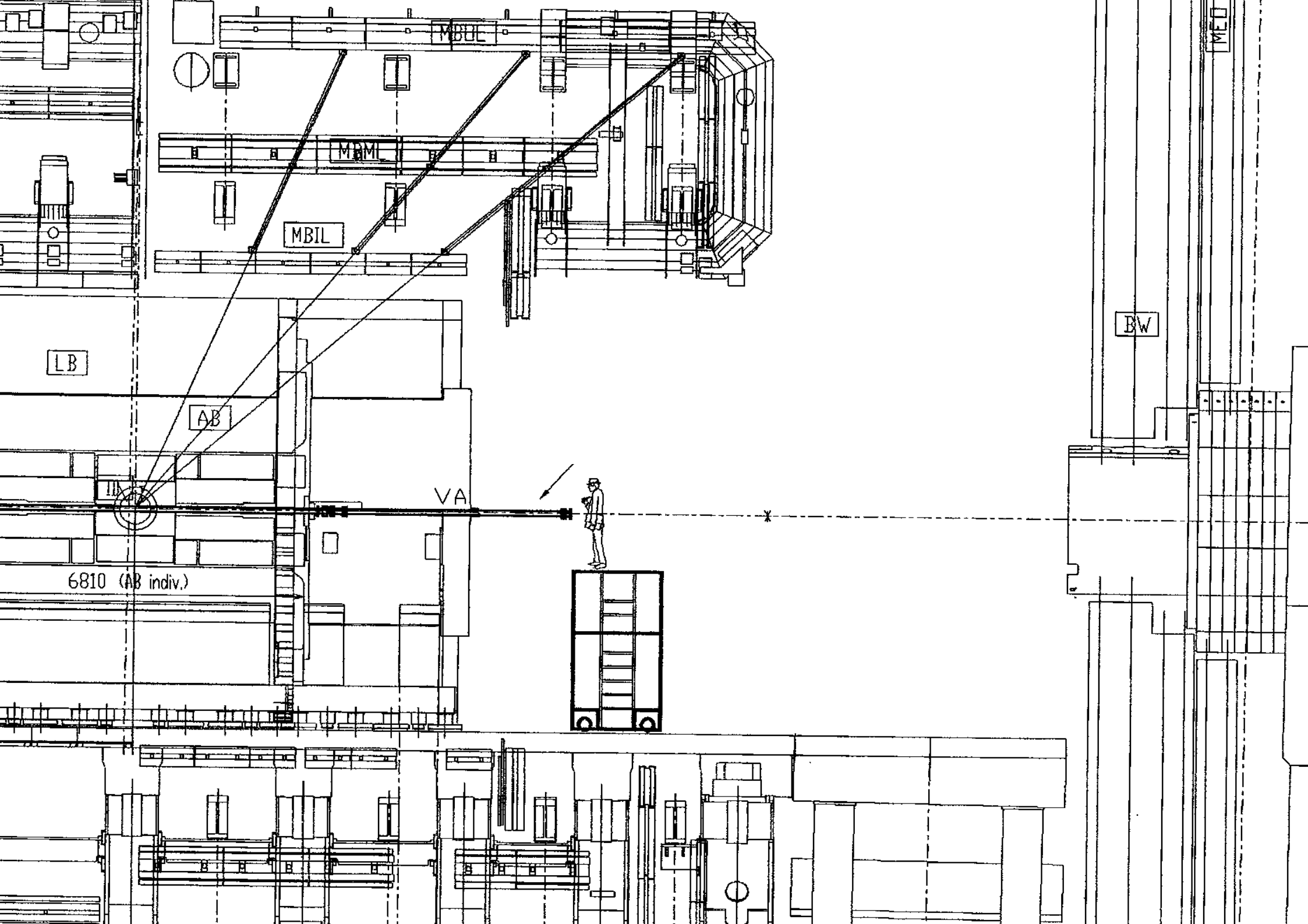

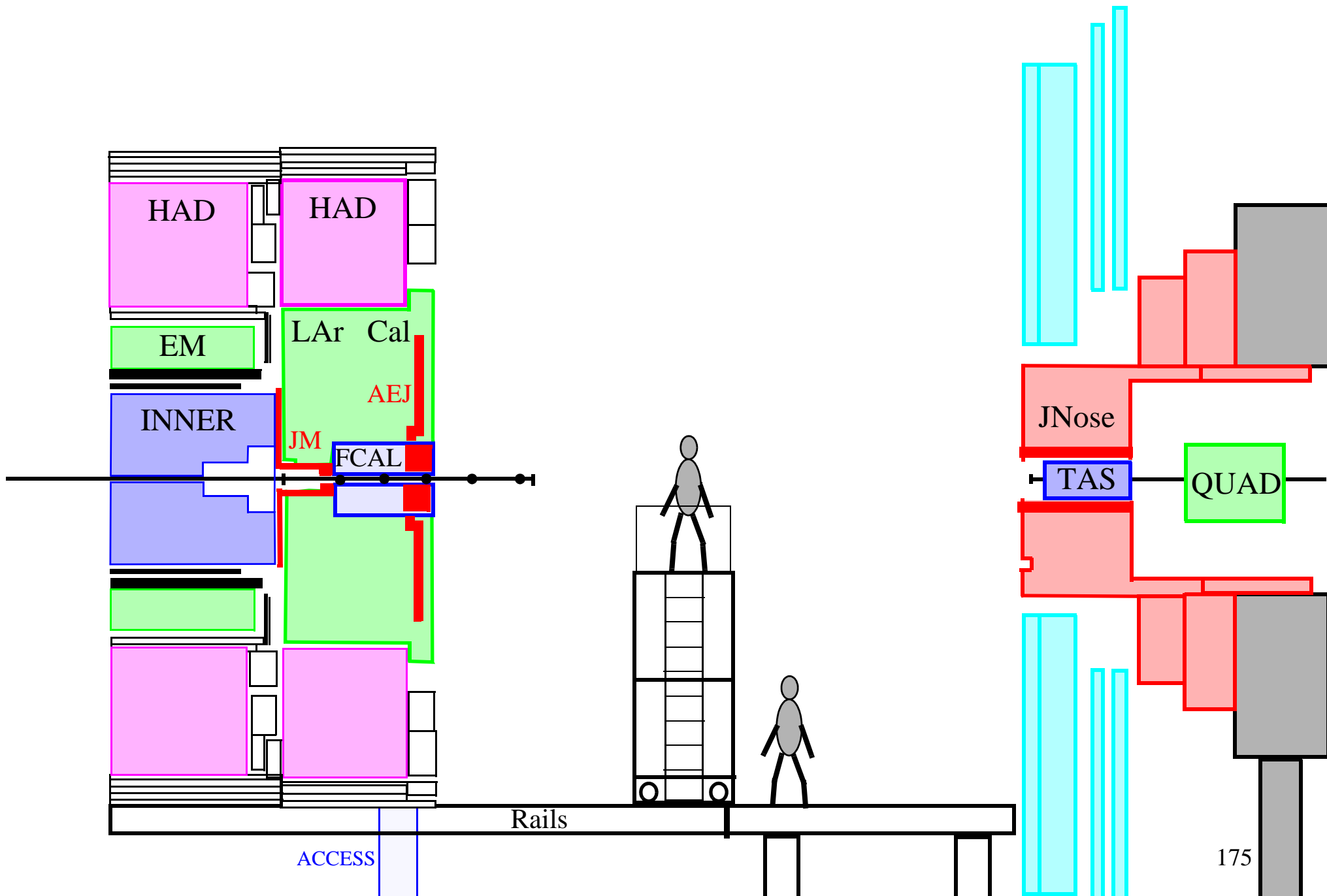

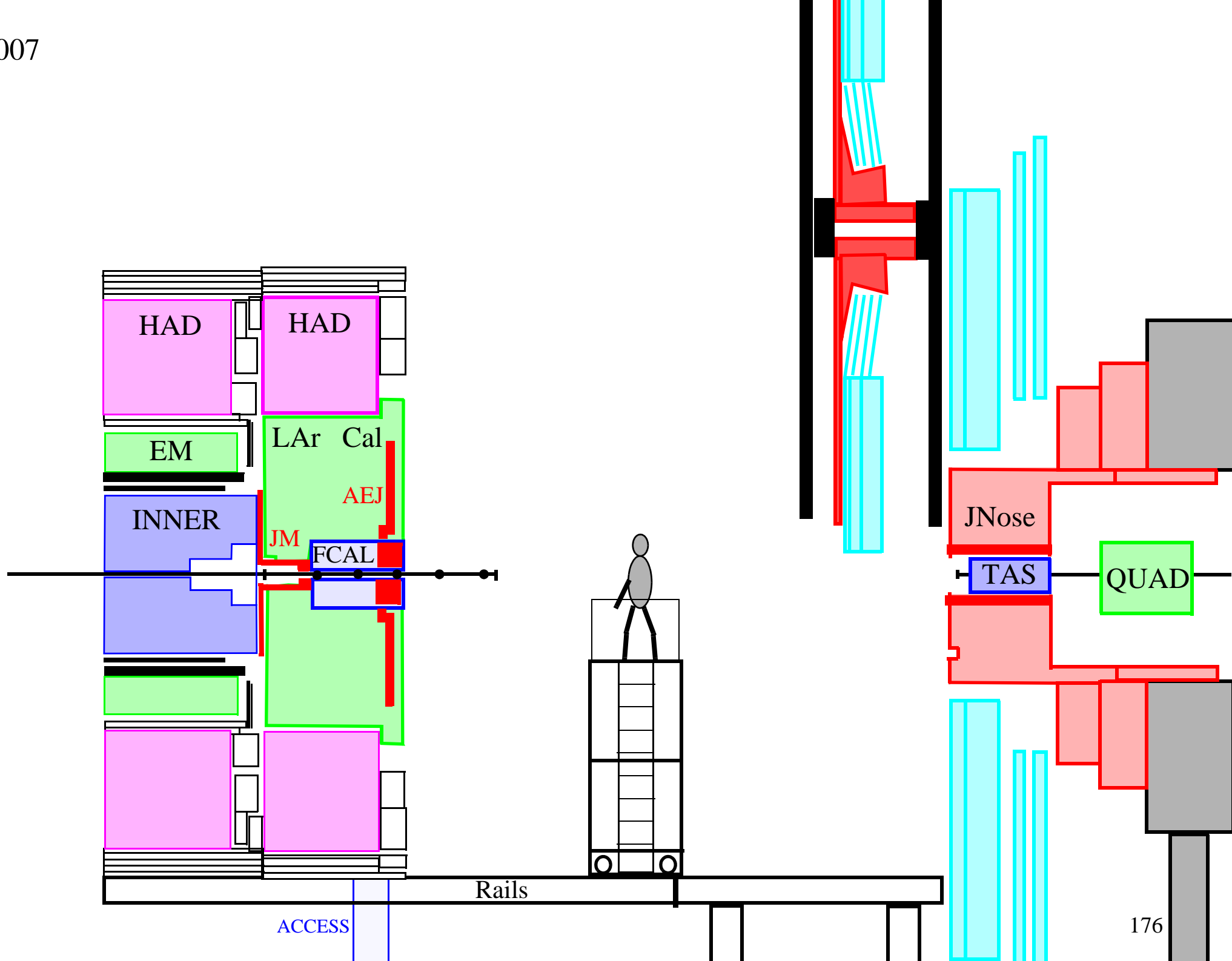

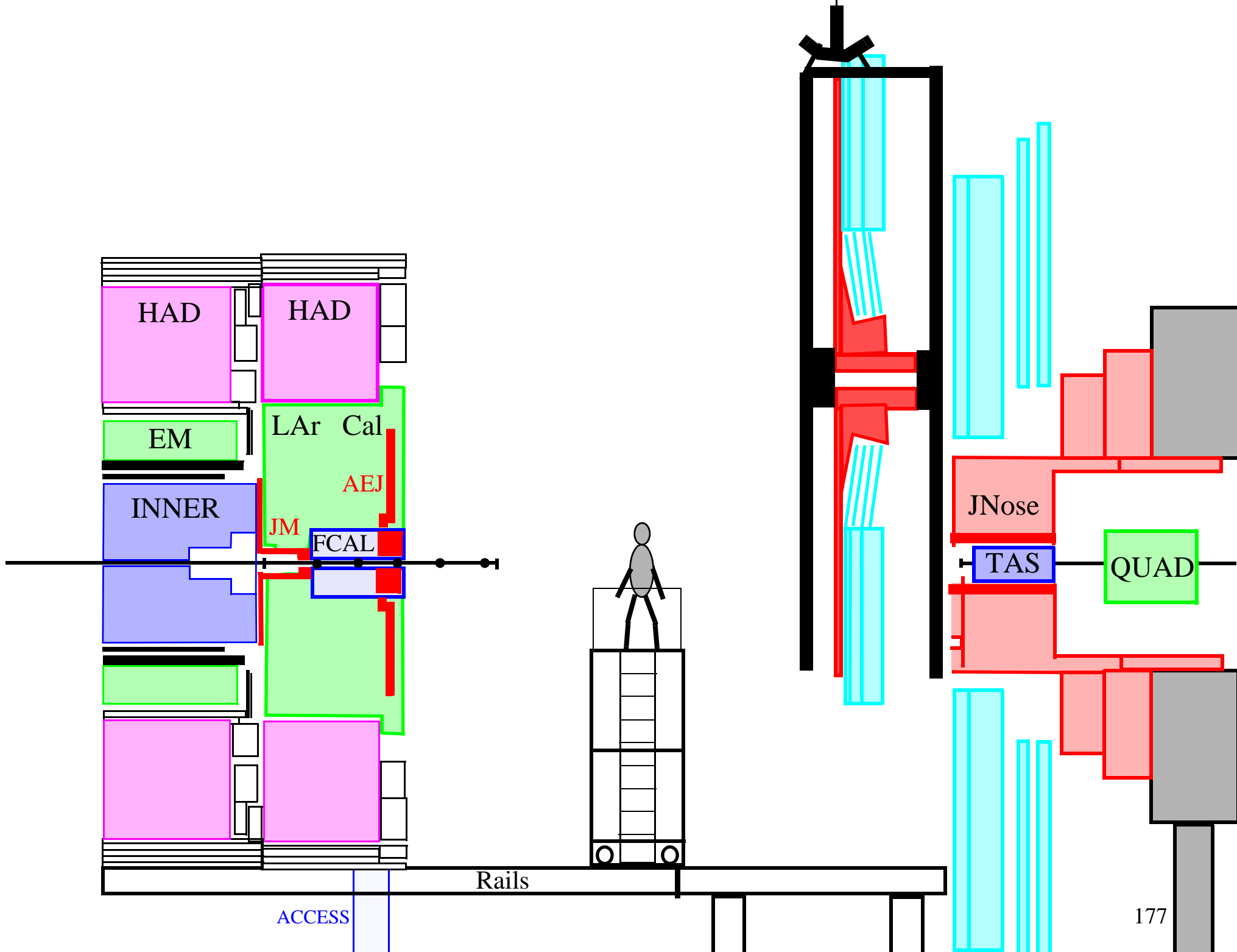

The JD/SW has to be moved in sideways to get under the ECT services.

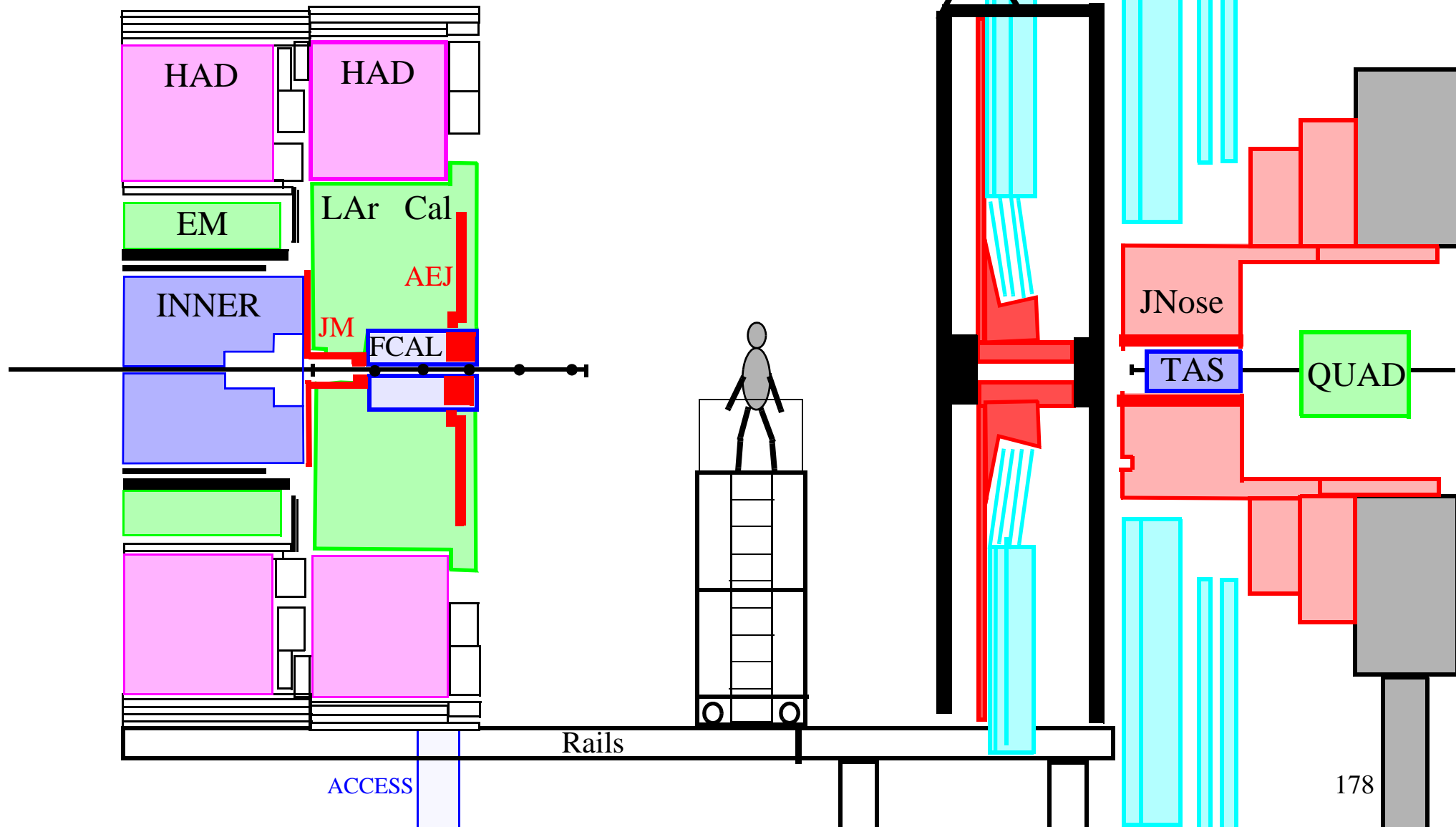

20 T THEORETICAL ZONE

20 T SAFETY ZONE

20 F EXTENDED ZONE

ECT

Liftingpoints

JD

JN

15787

437

1475

1664

800

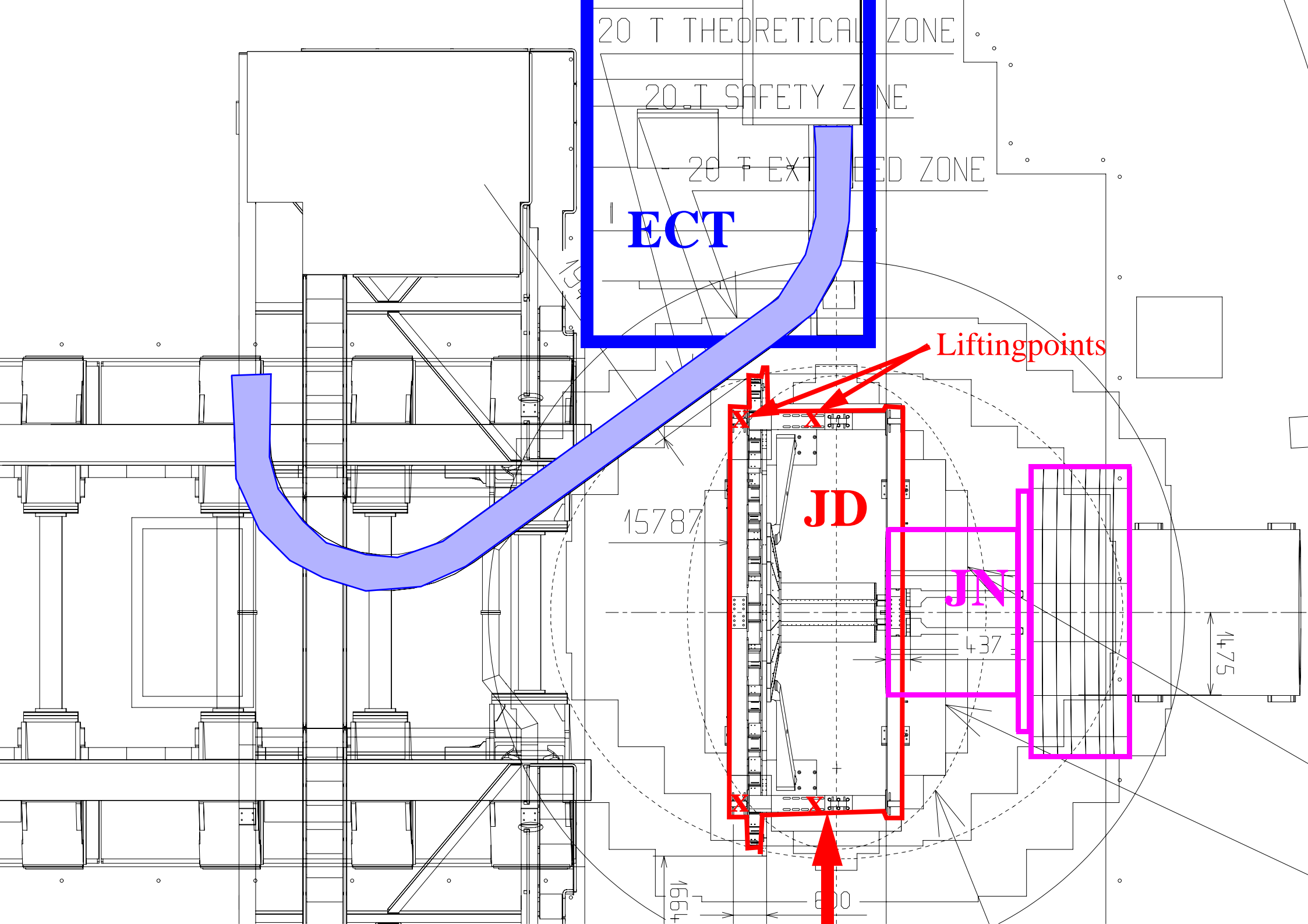

The JD/SW has to be moved towards the IP on its airpads.

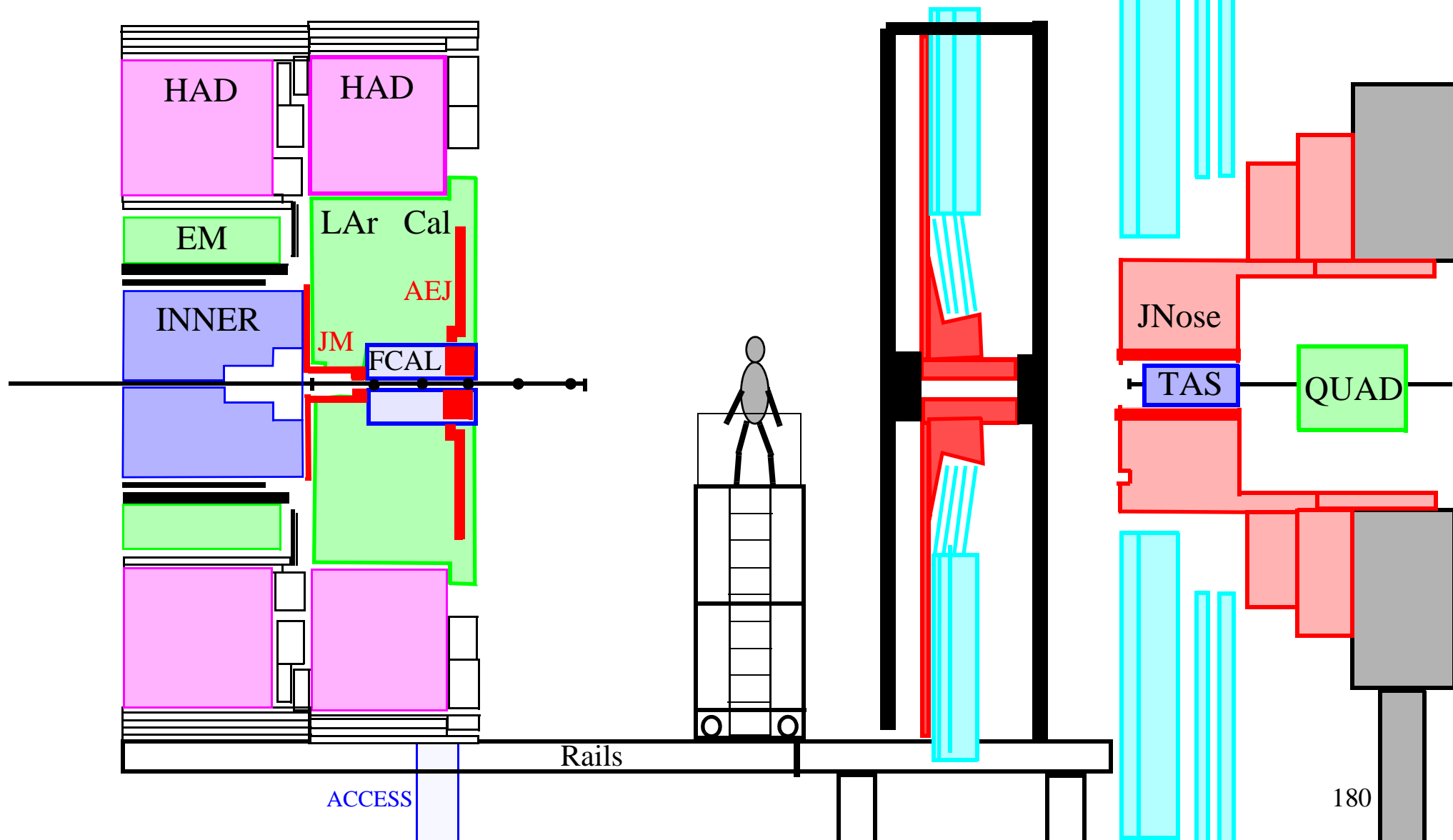

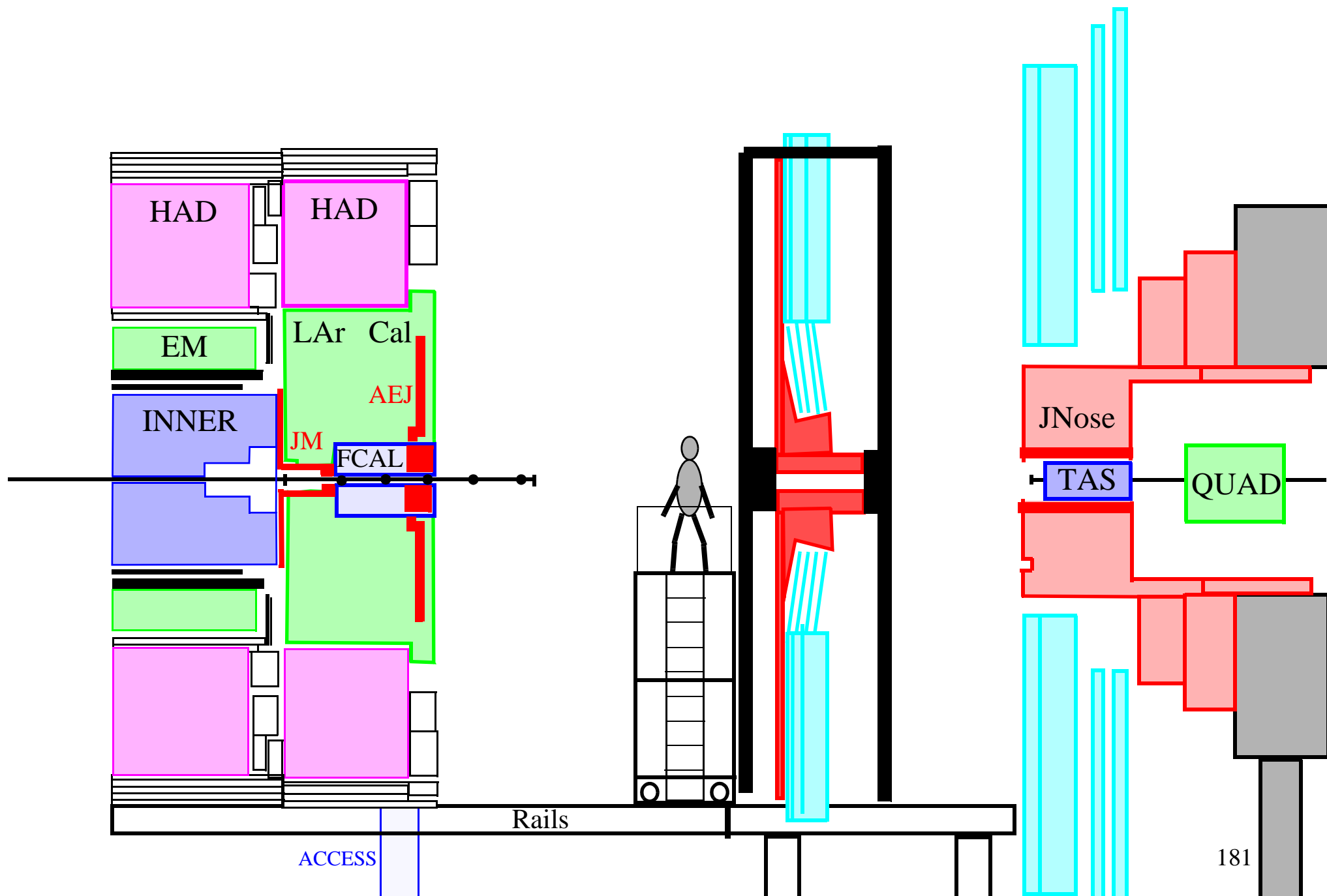

20 T THEORETICAL ZONE

20 T SAFETY ZONE

20 F EXTENDED ZONE

ECT

JD

15787

JN

437

1475

1564

600

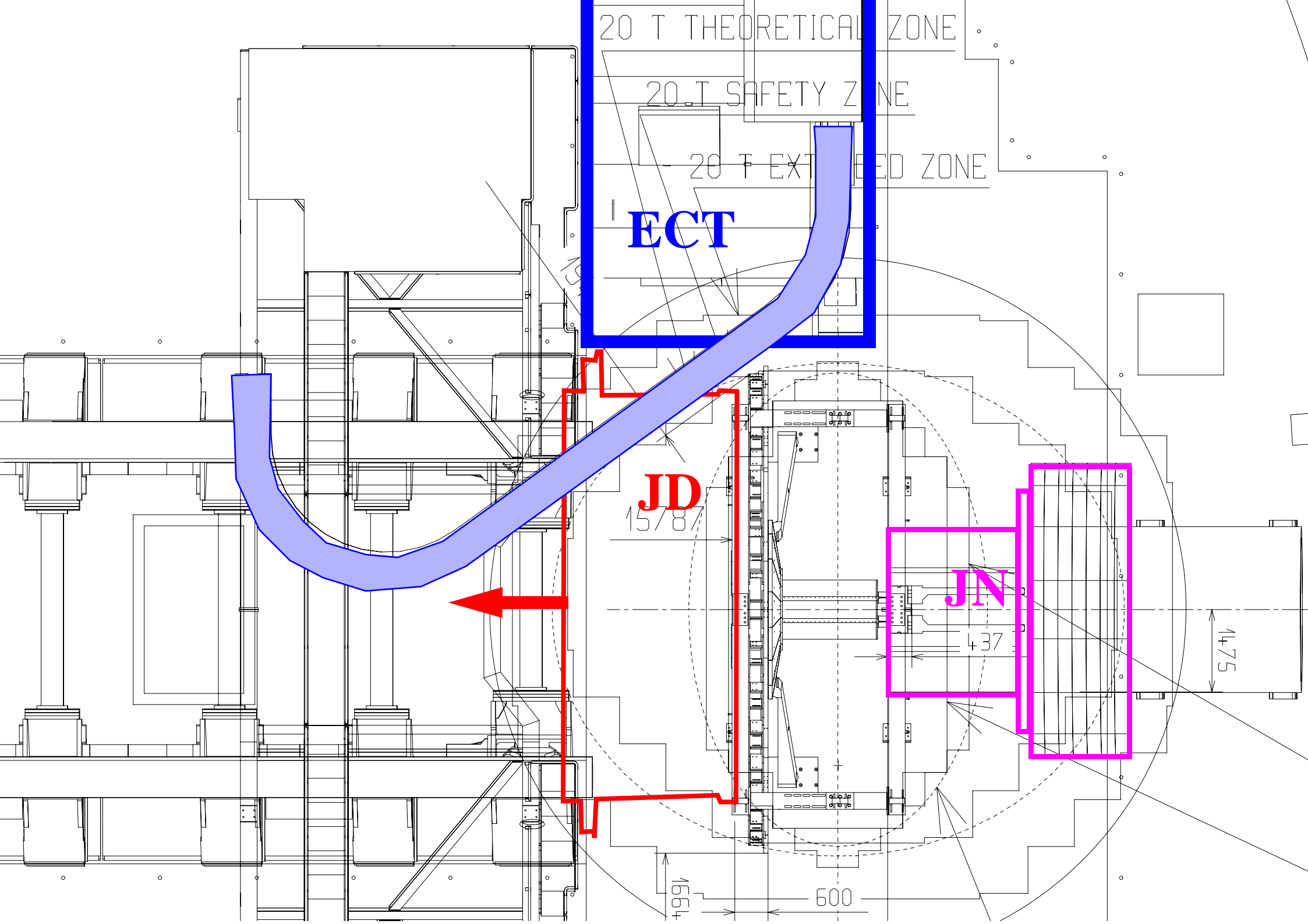

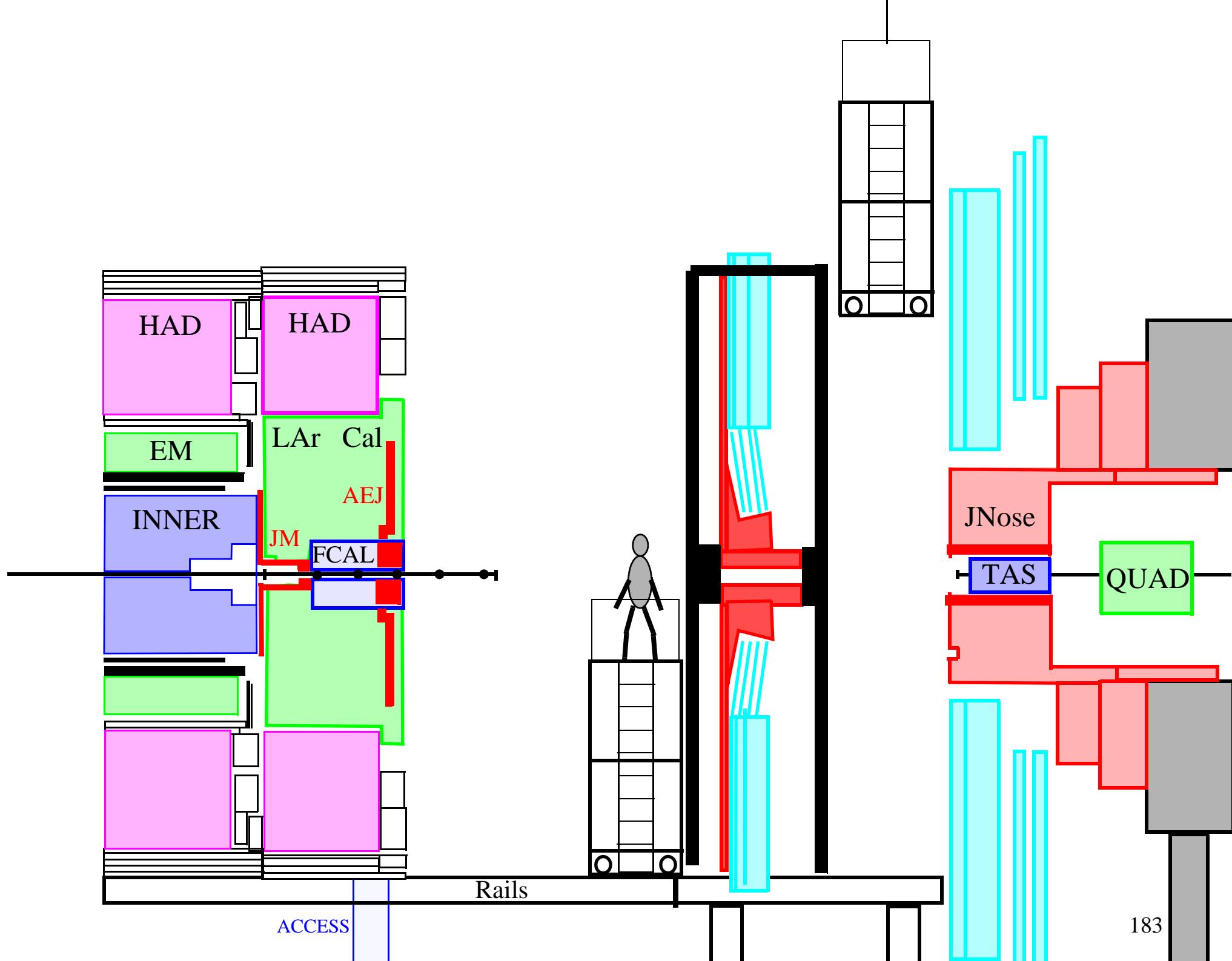

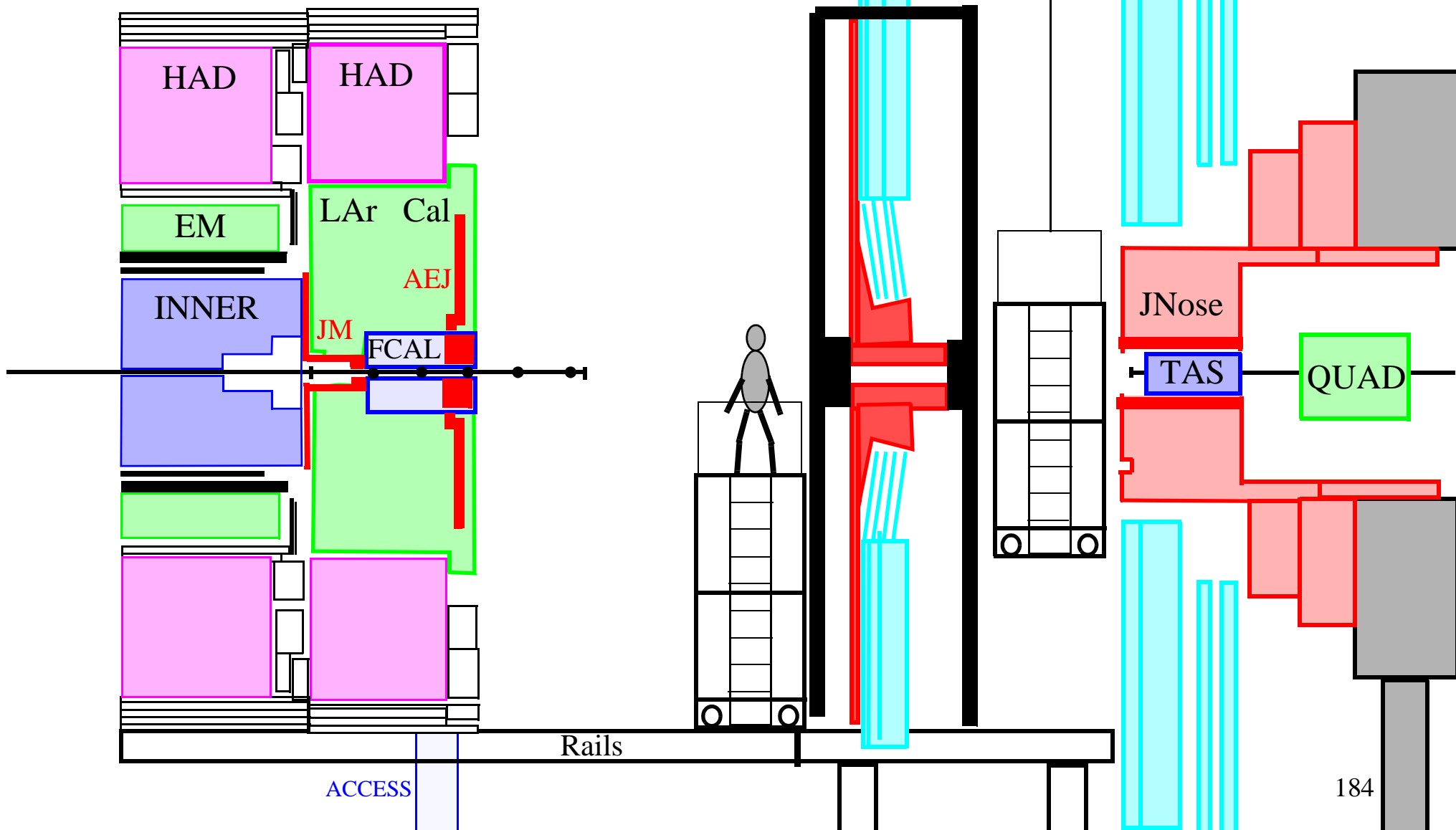

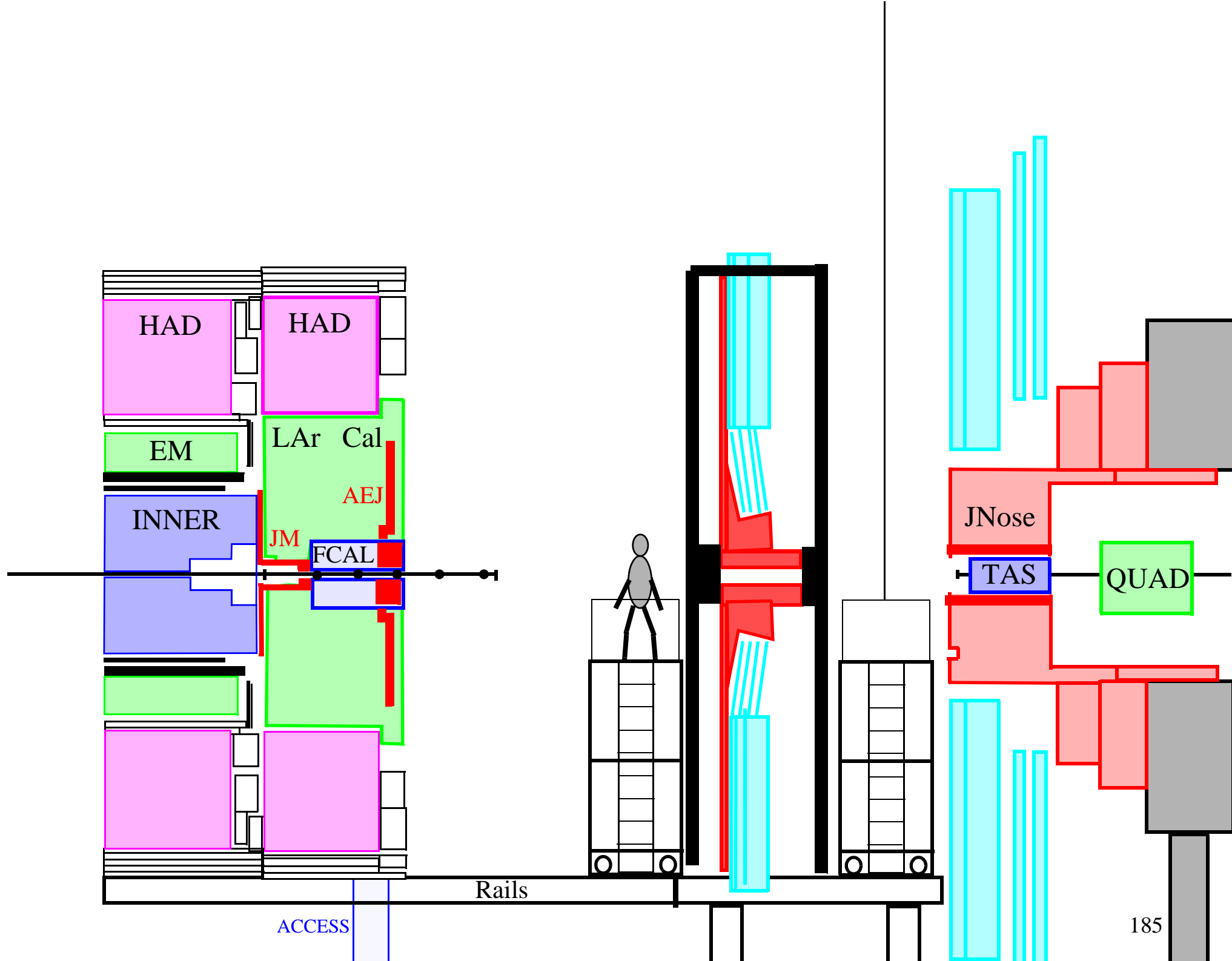

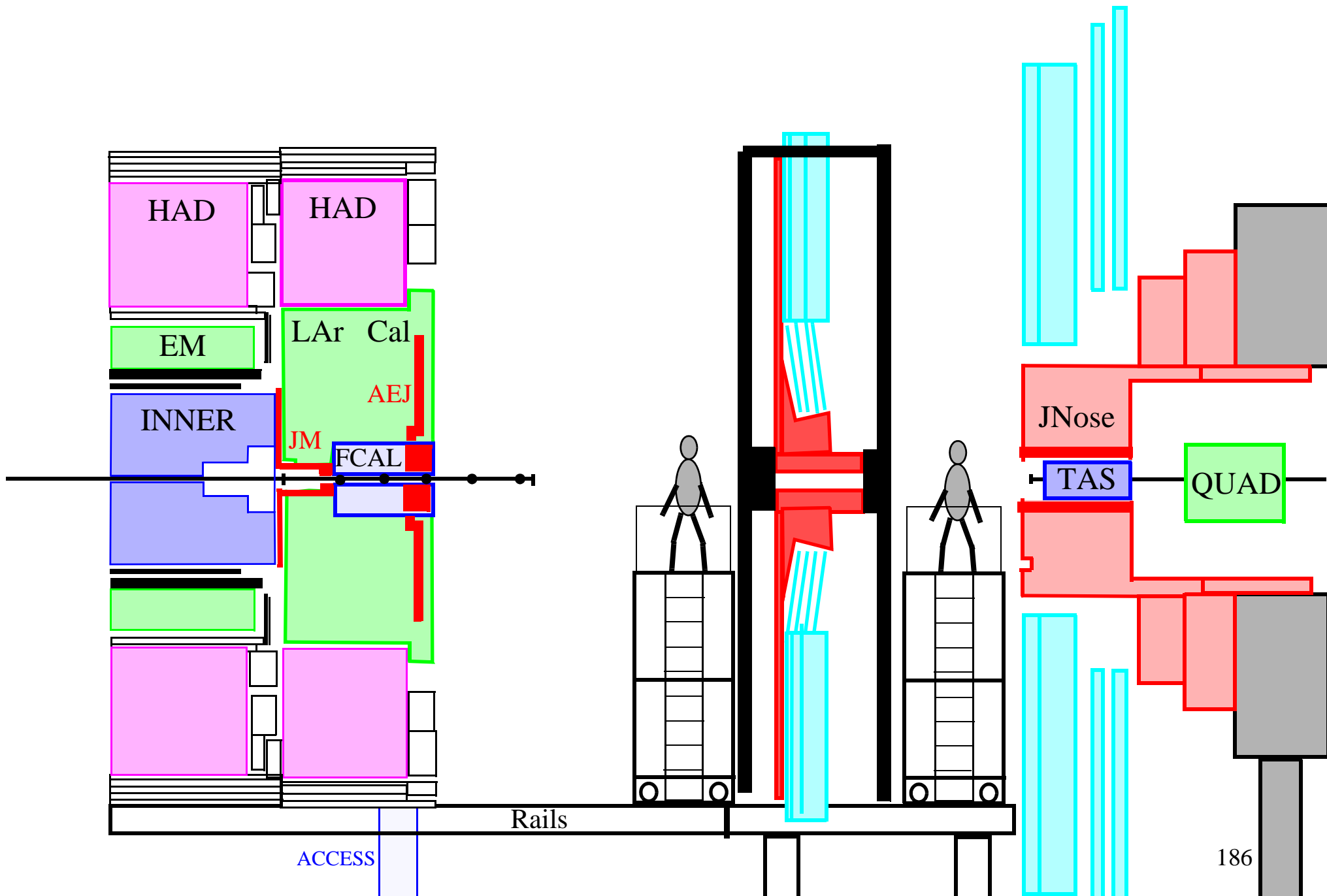

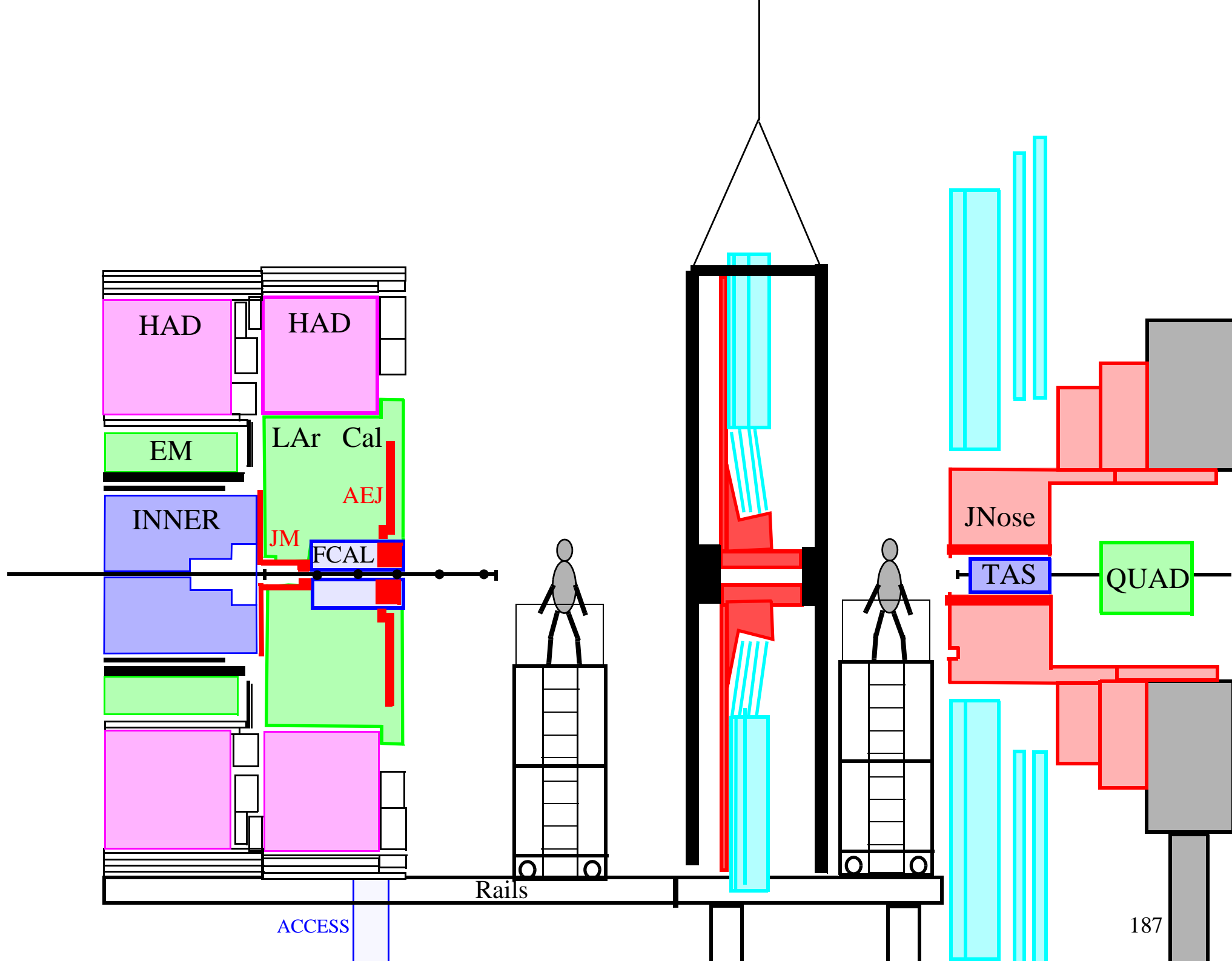

HAD

HAD

EM

LAr Cal

INNER

AEJ

JM

FCAL

JNose

TAS

QUAD

RAILS

ACCESS

20 T THEORETICAL ZONE

20 T SAFETY ZONE

20 F EXTENDED ZONE

ECT

New
Liftingpoints

JD

JN

15787

437

1475

1564

600

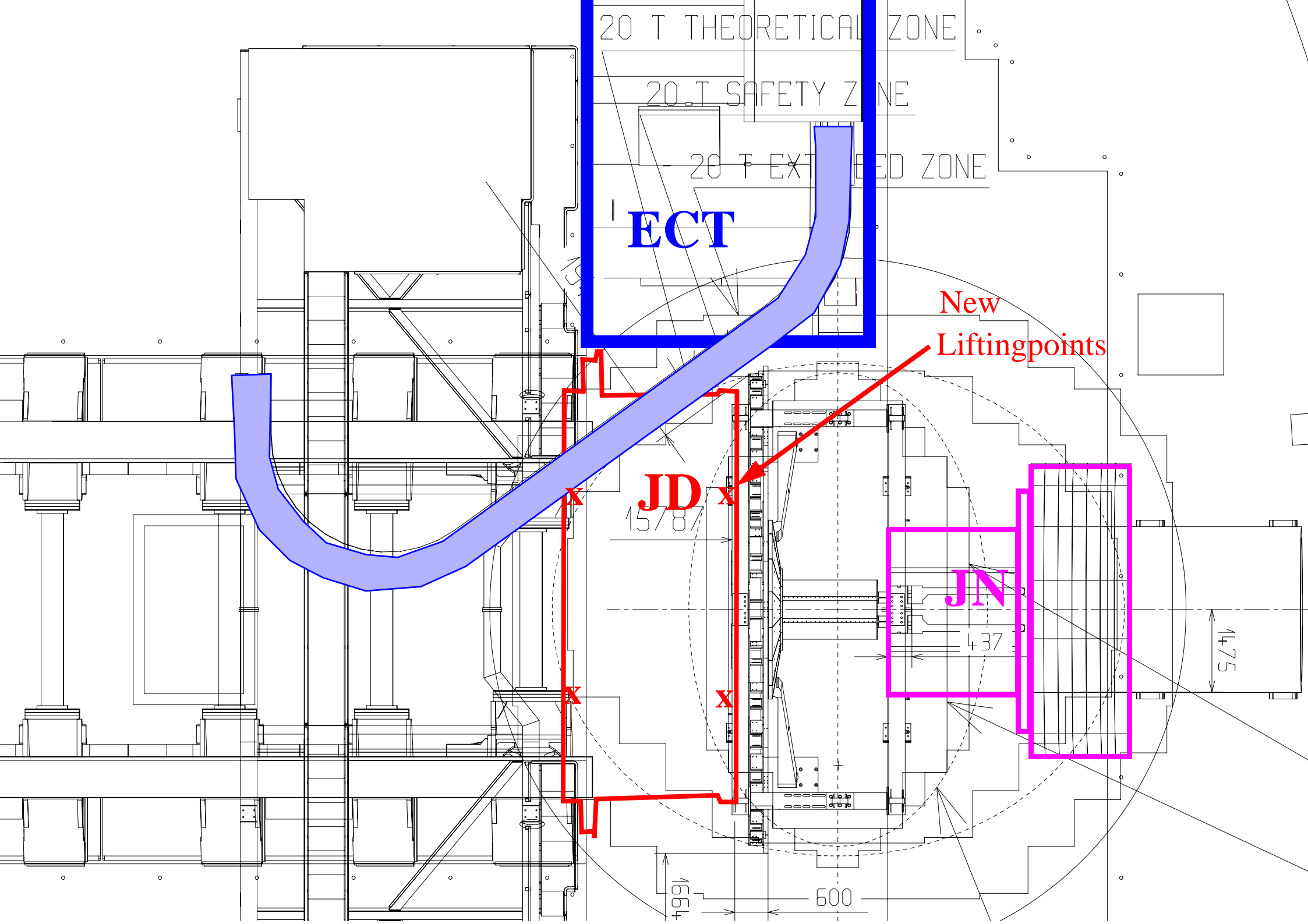

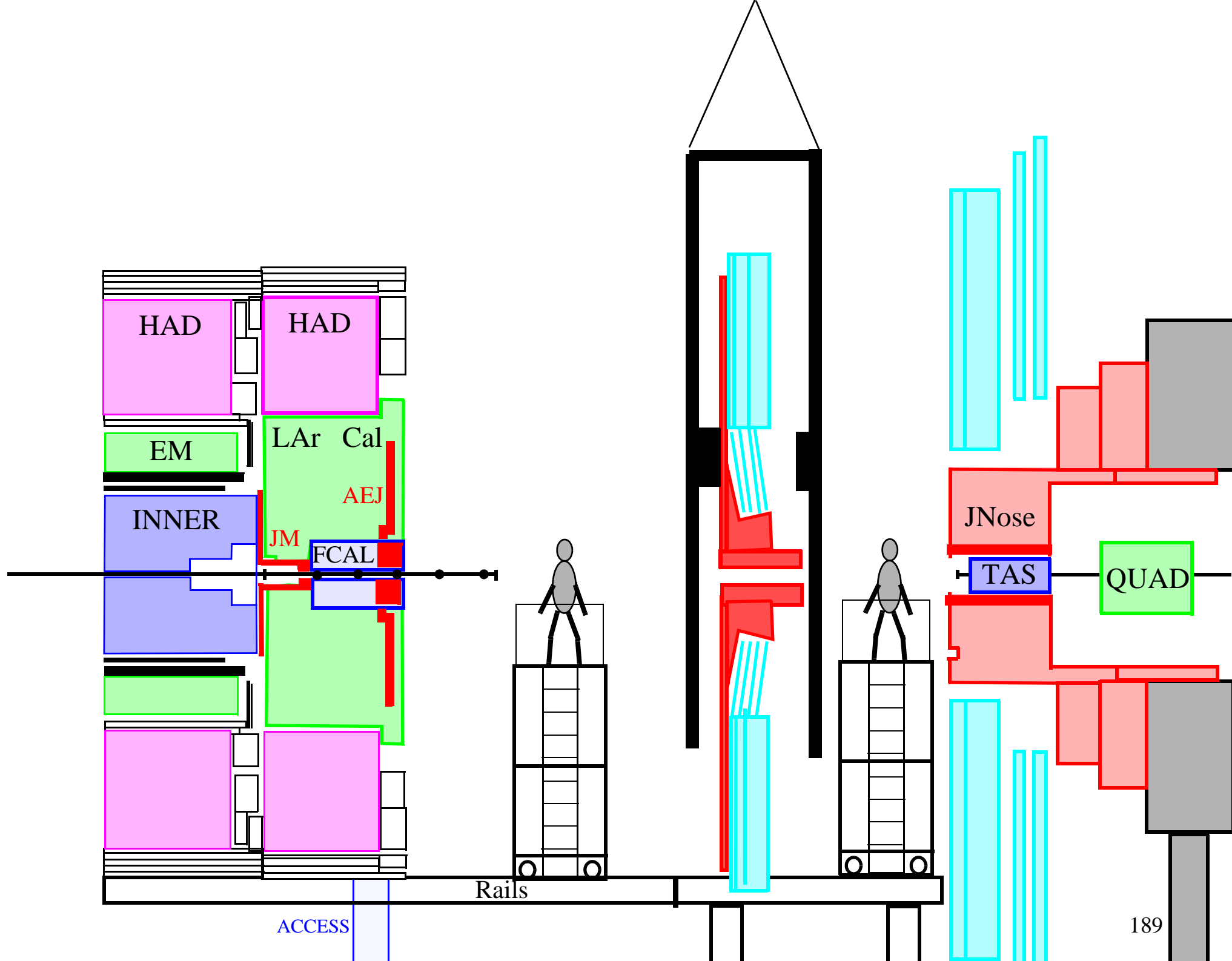

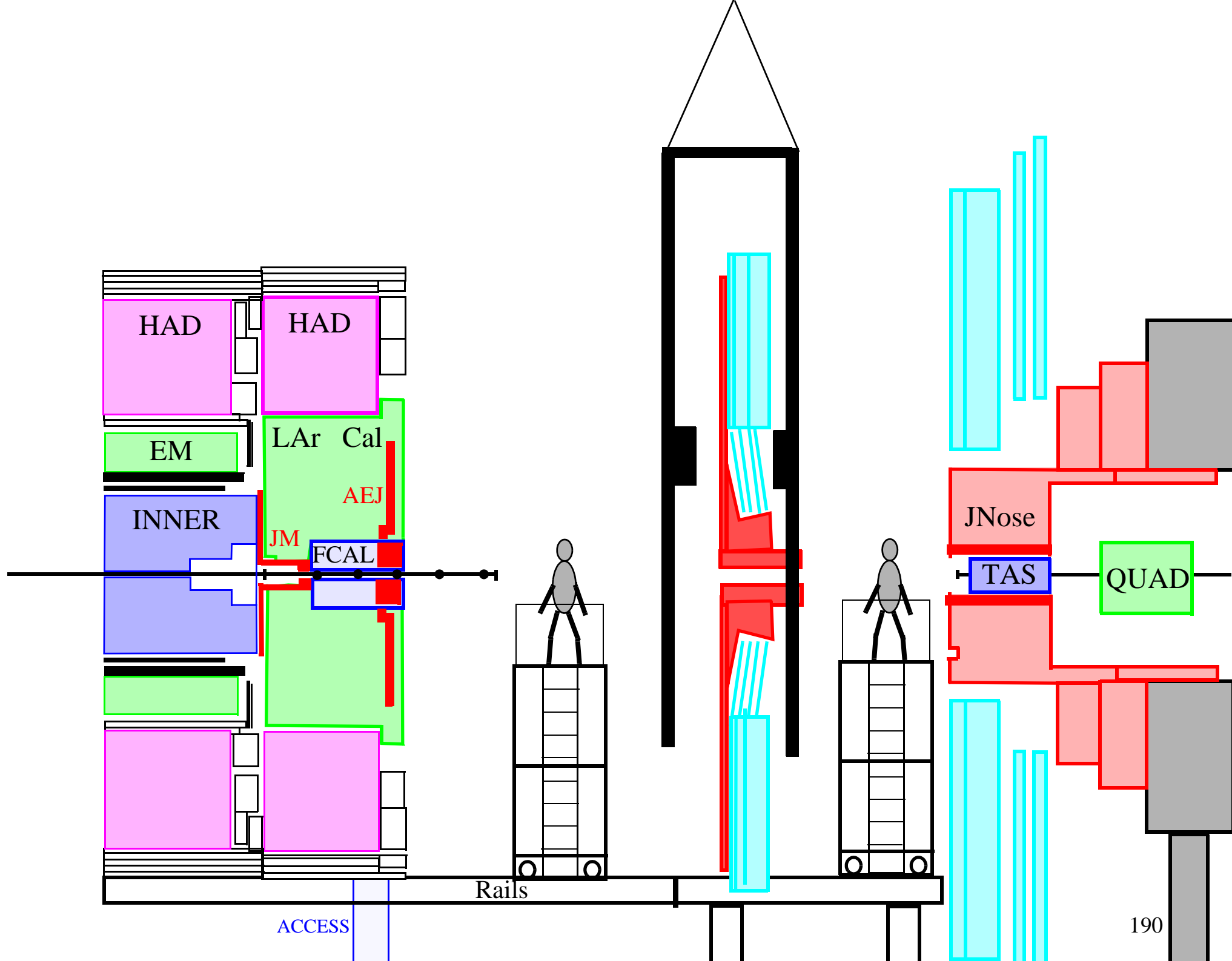

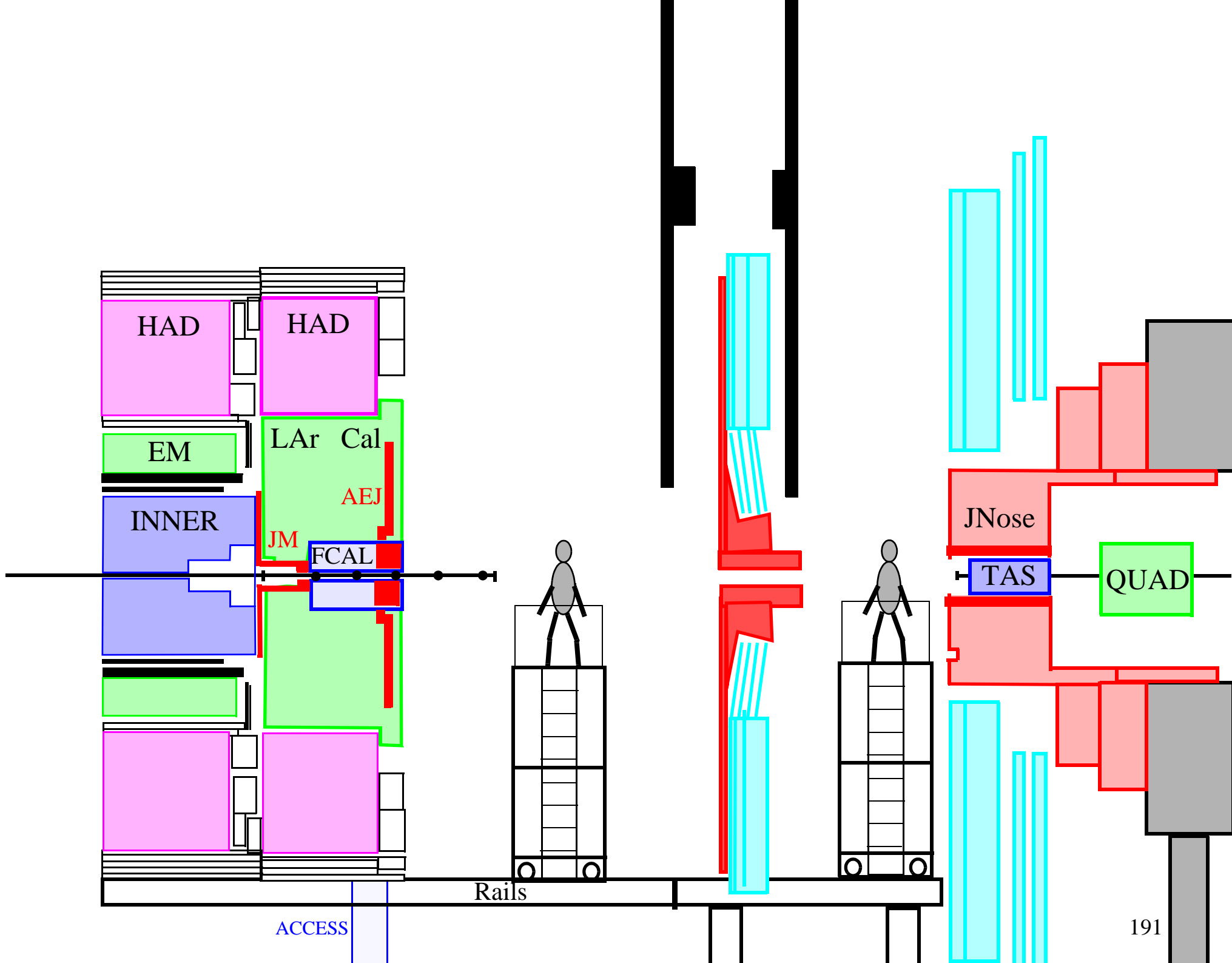

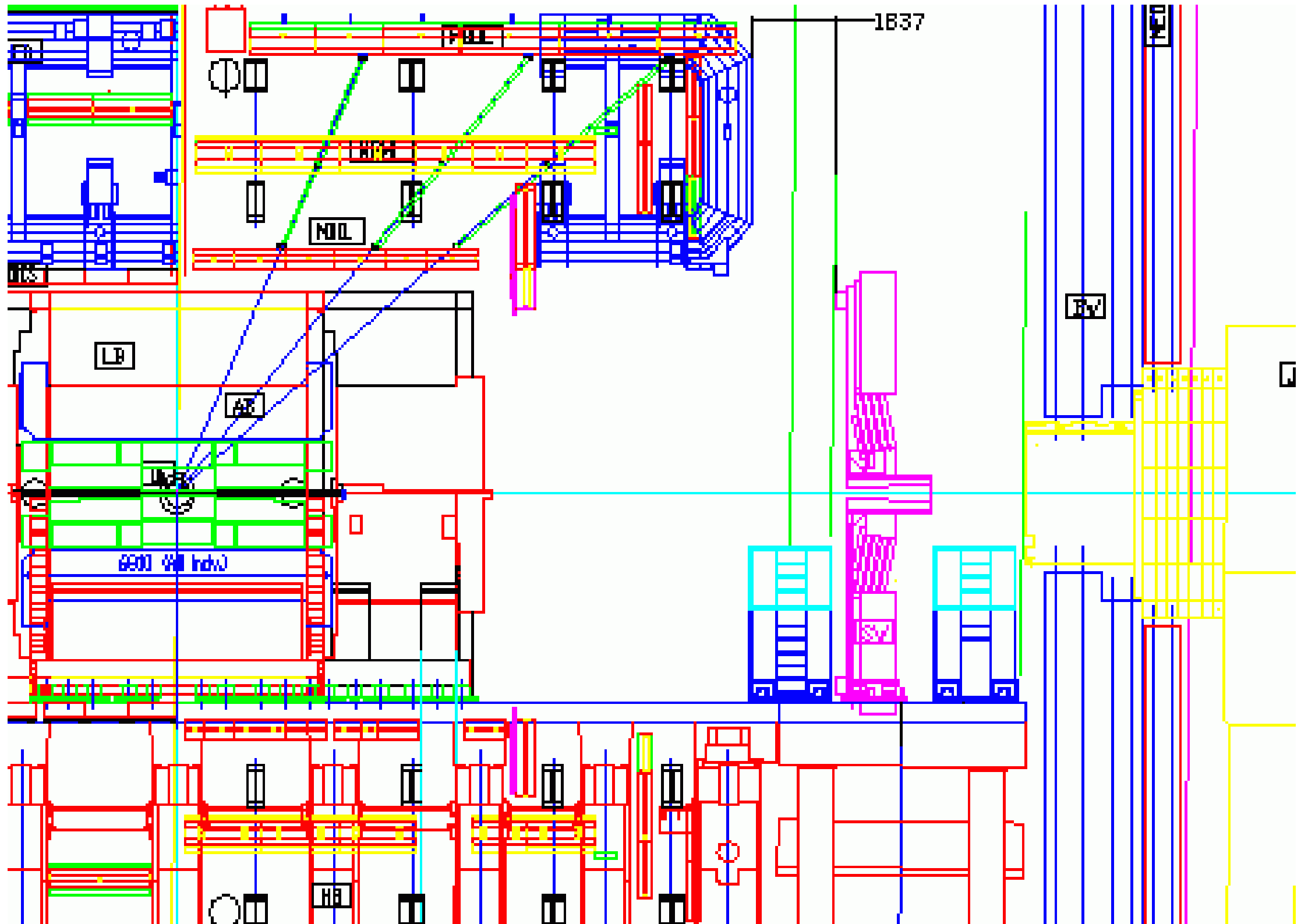

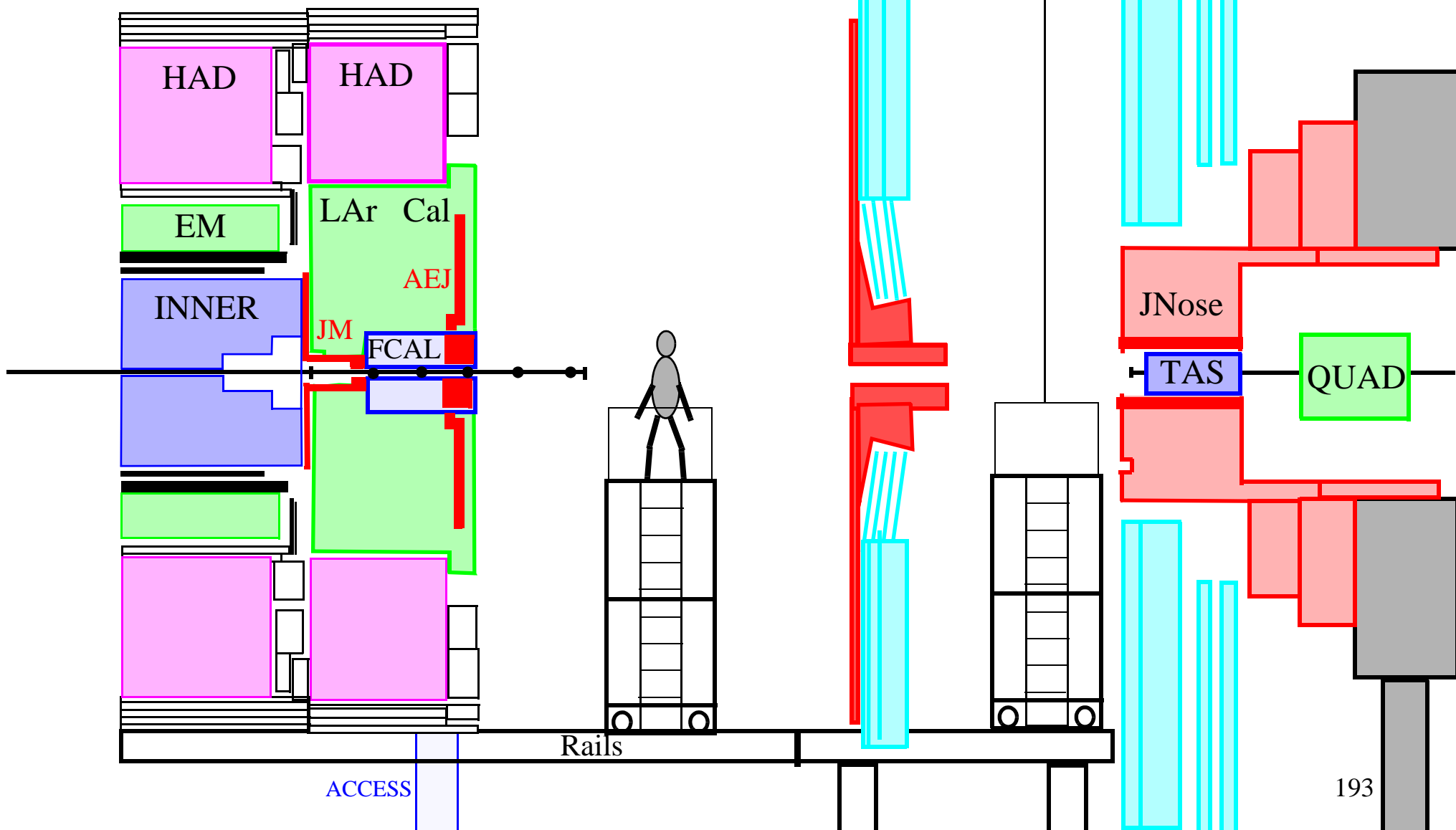

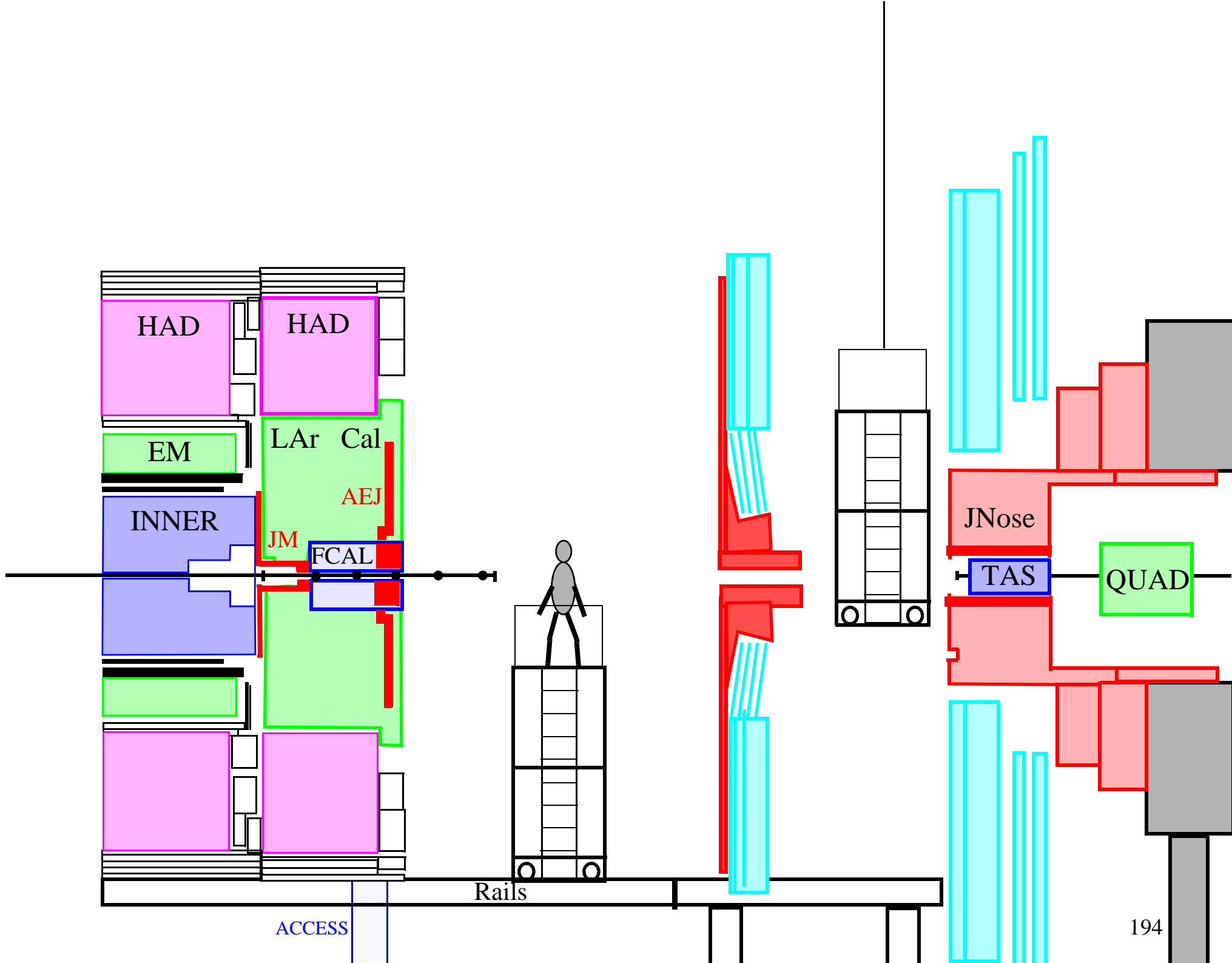

HAD

HAD

EM

LAr Cal

INNER

AEJ

JM

FCAL

Rails

ACCESS

JNose

TAS

QUAD

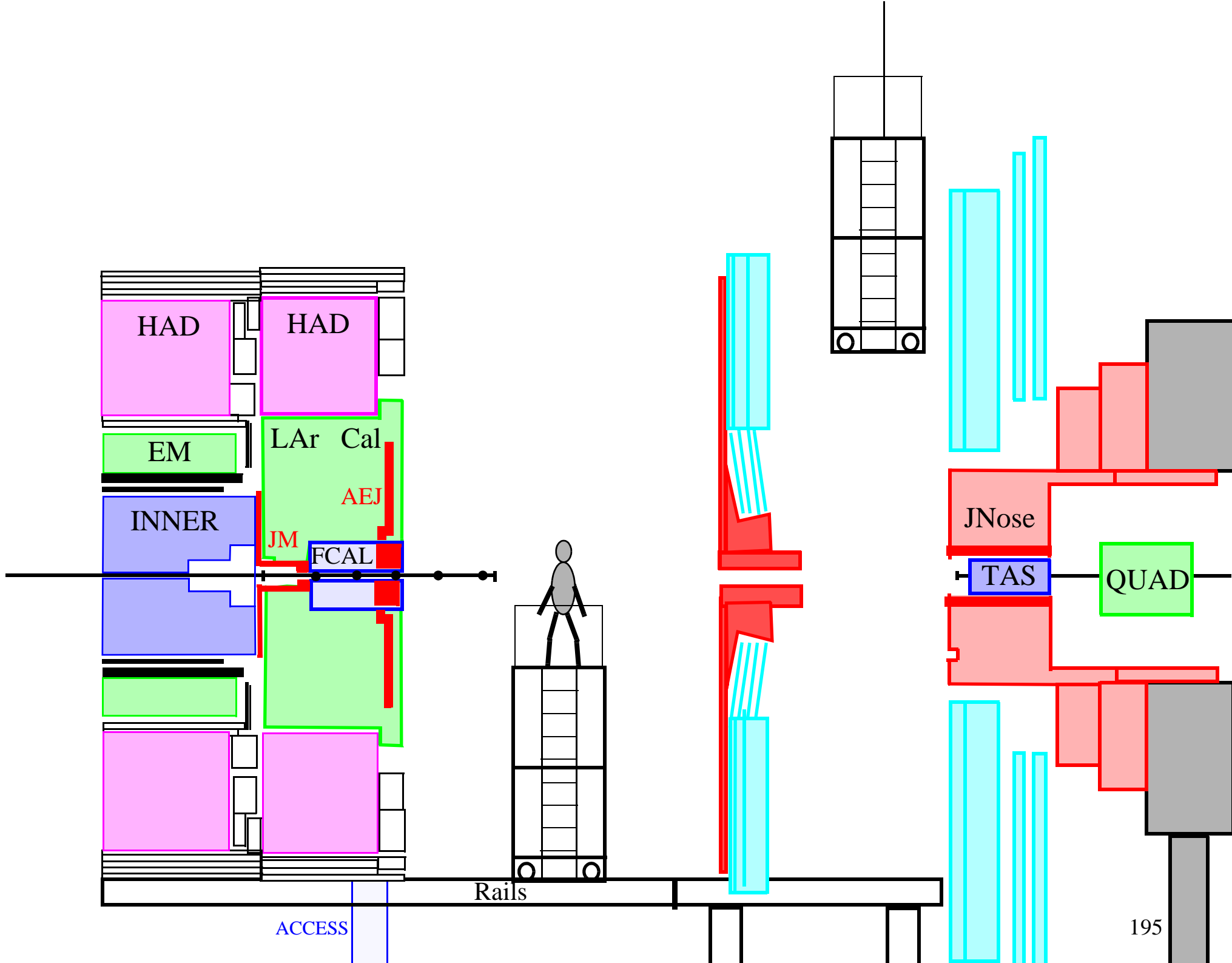

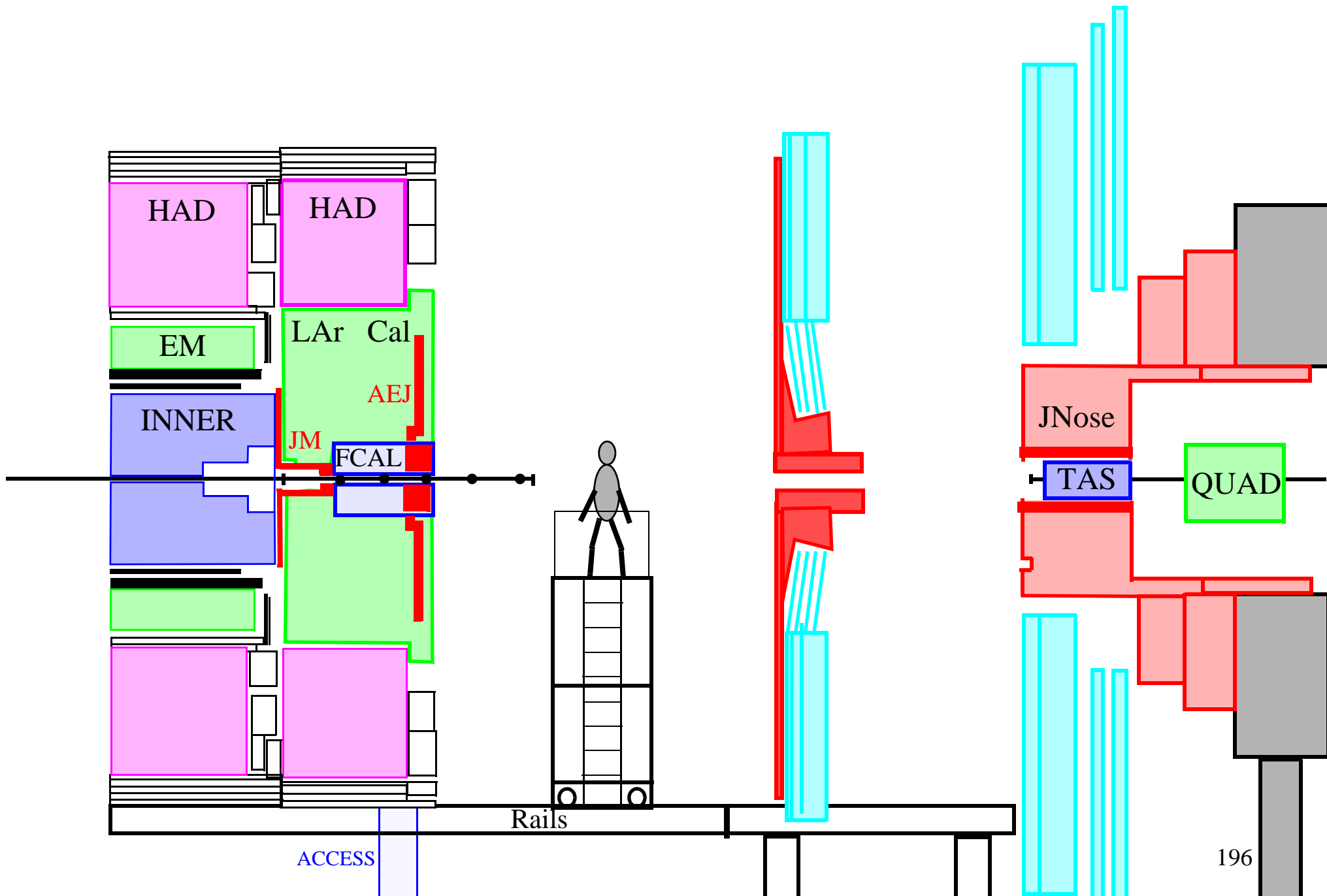

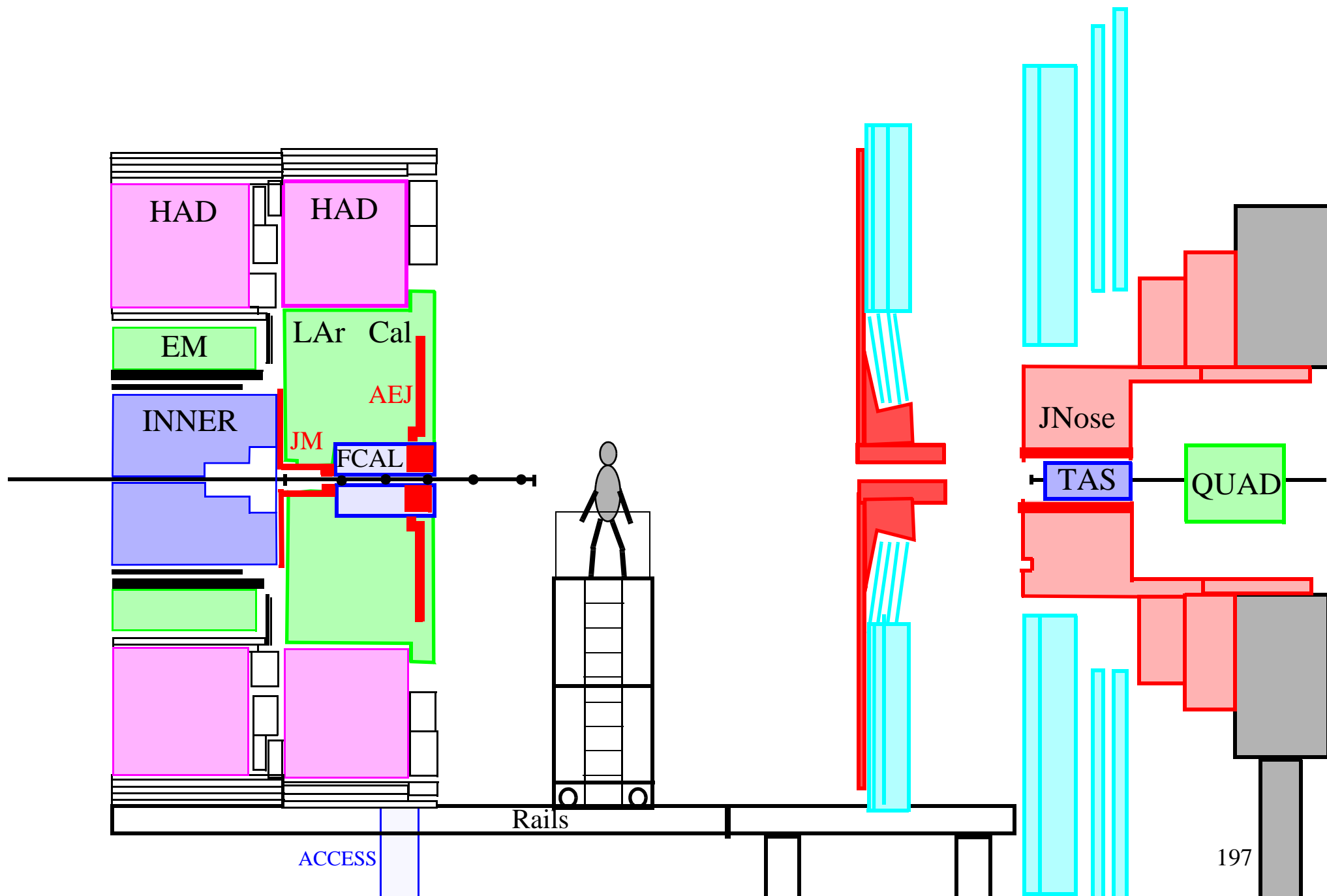

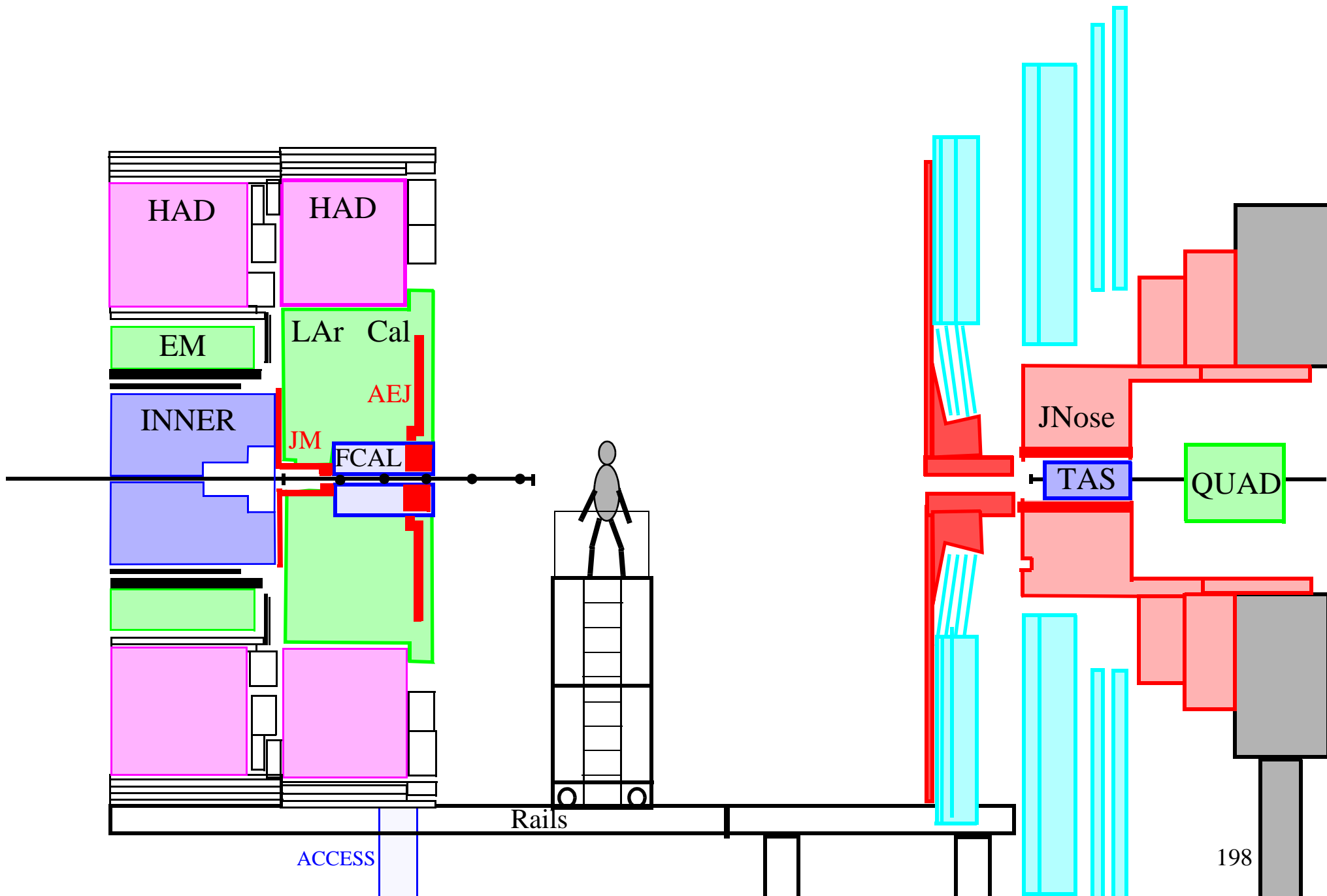

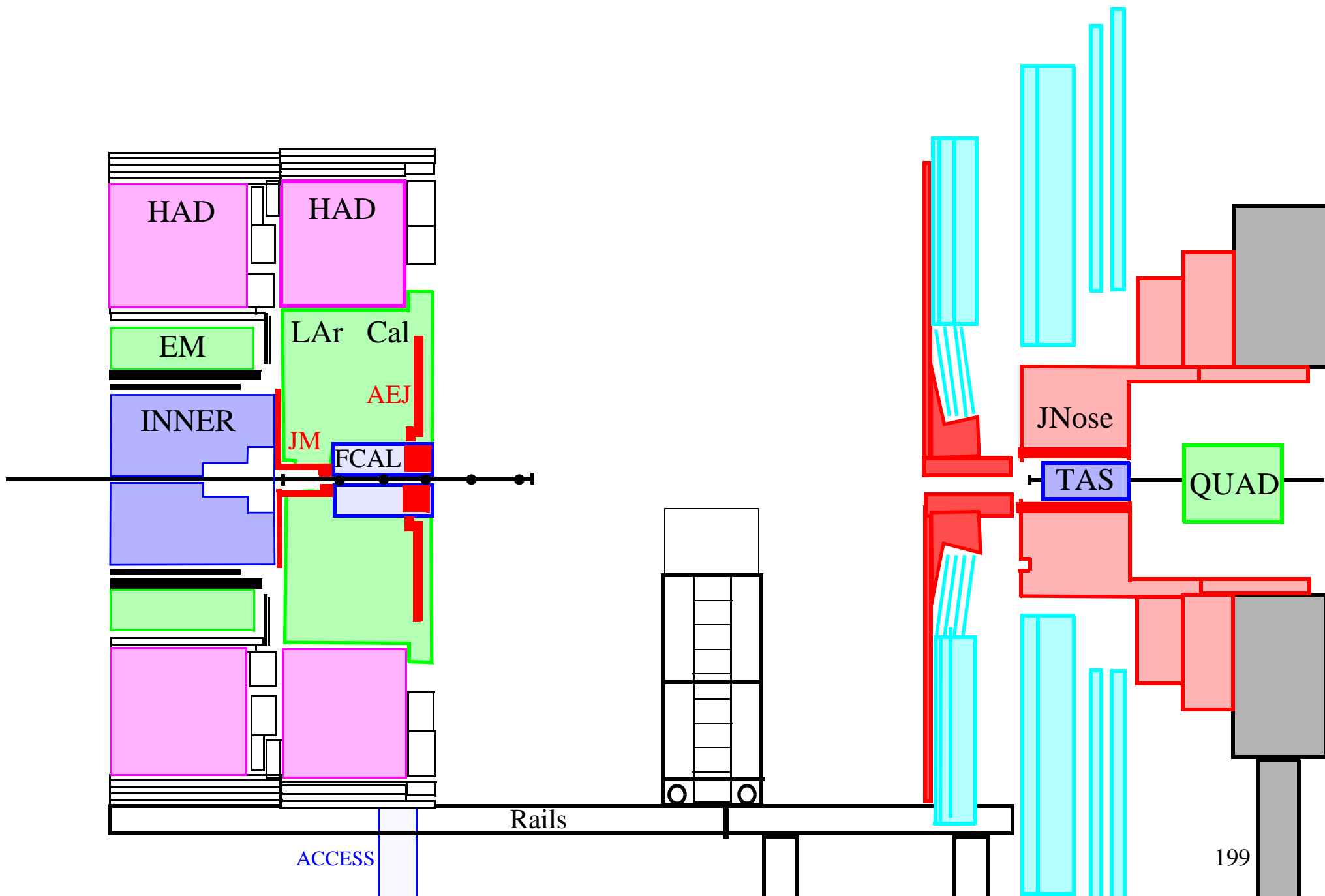

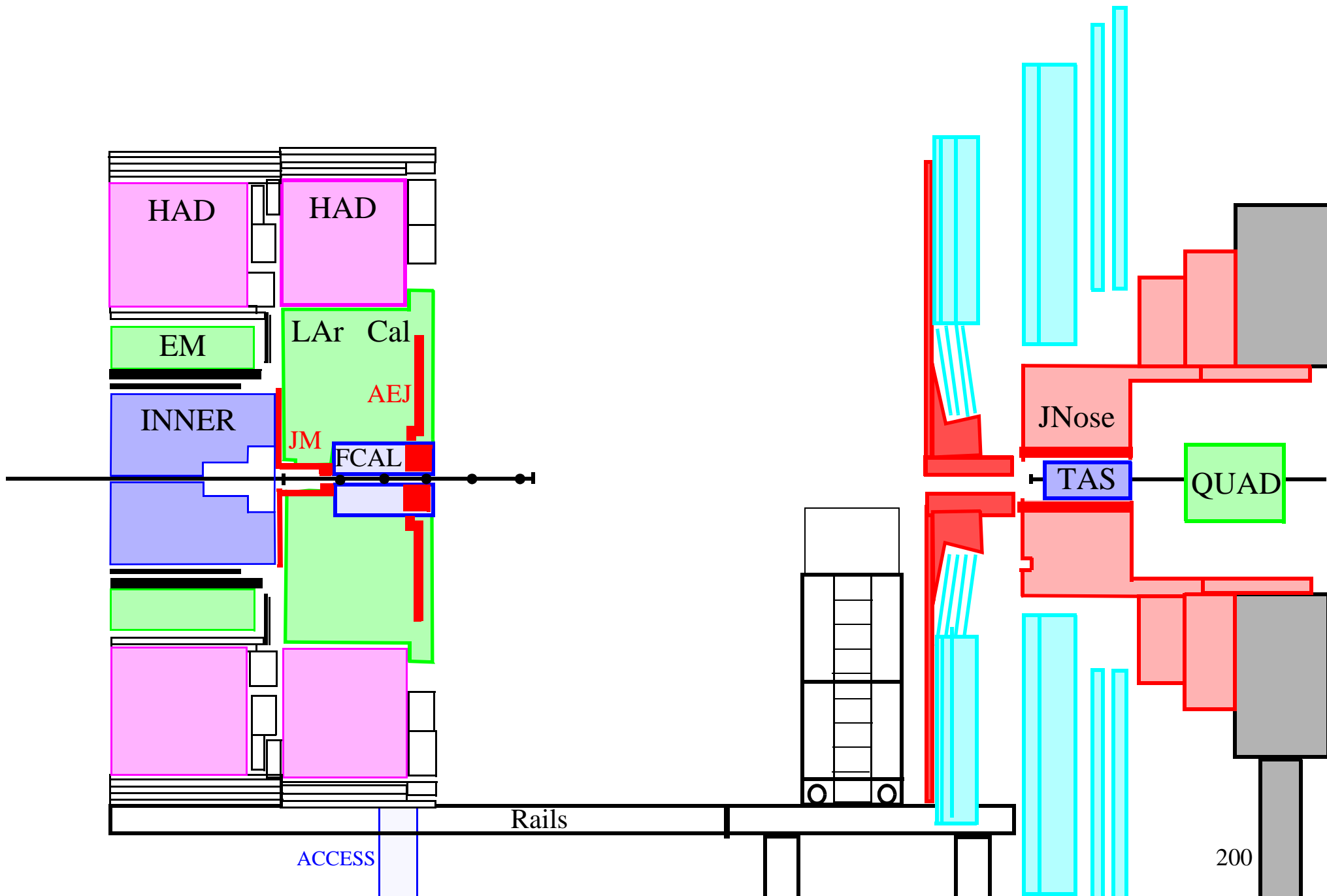

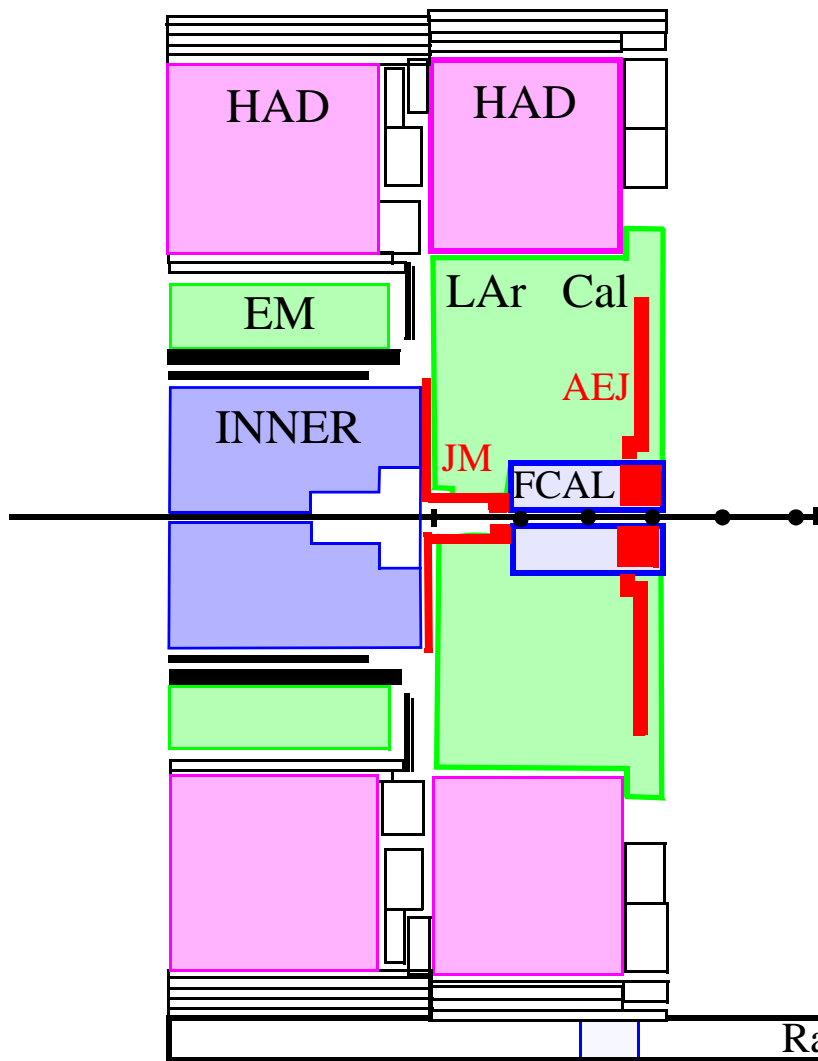

ACCESS

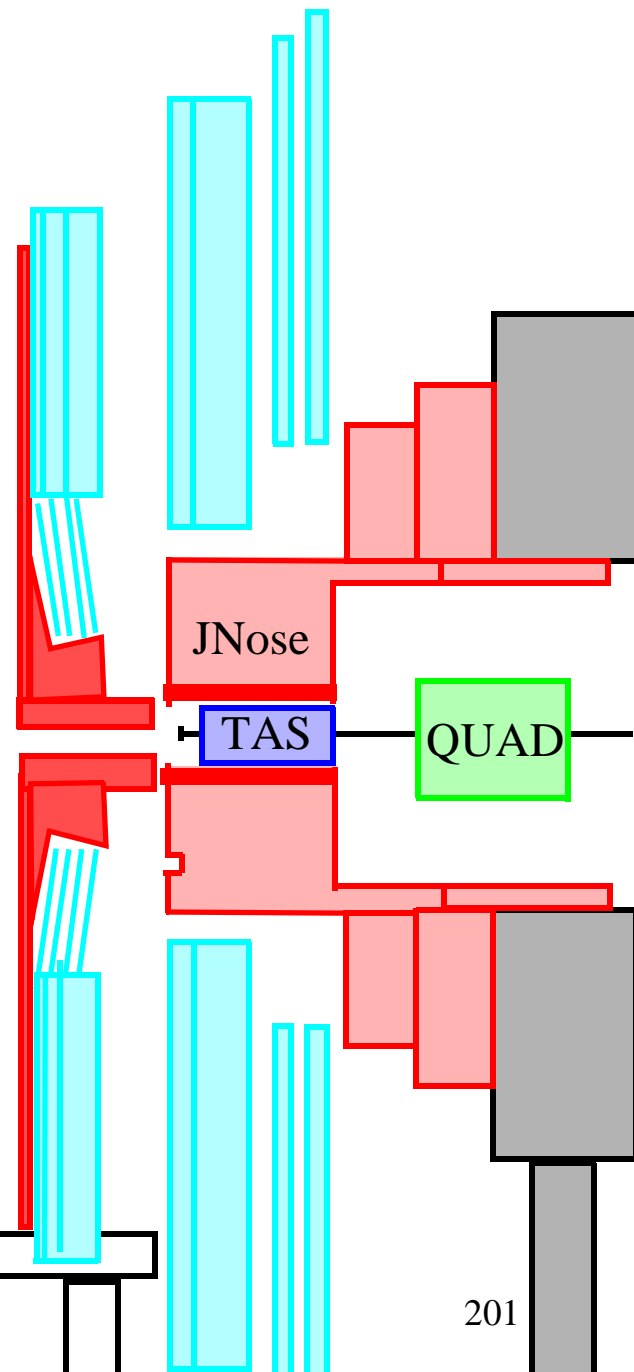
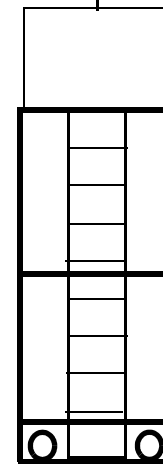

201

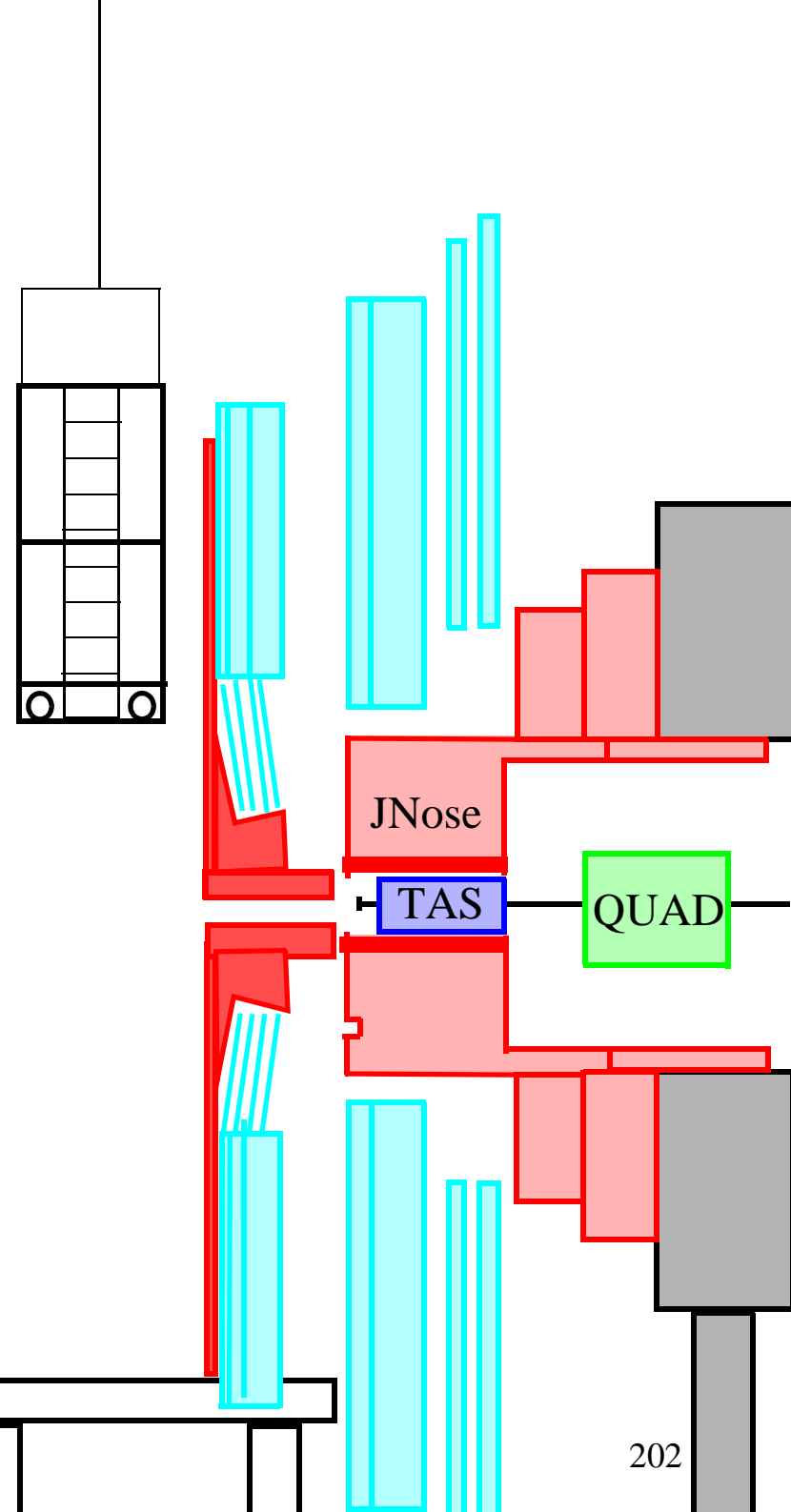
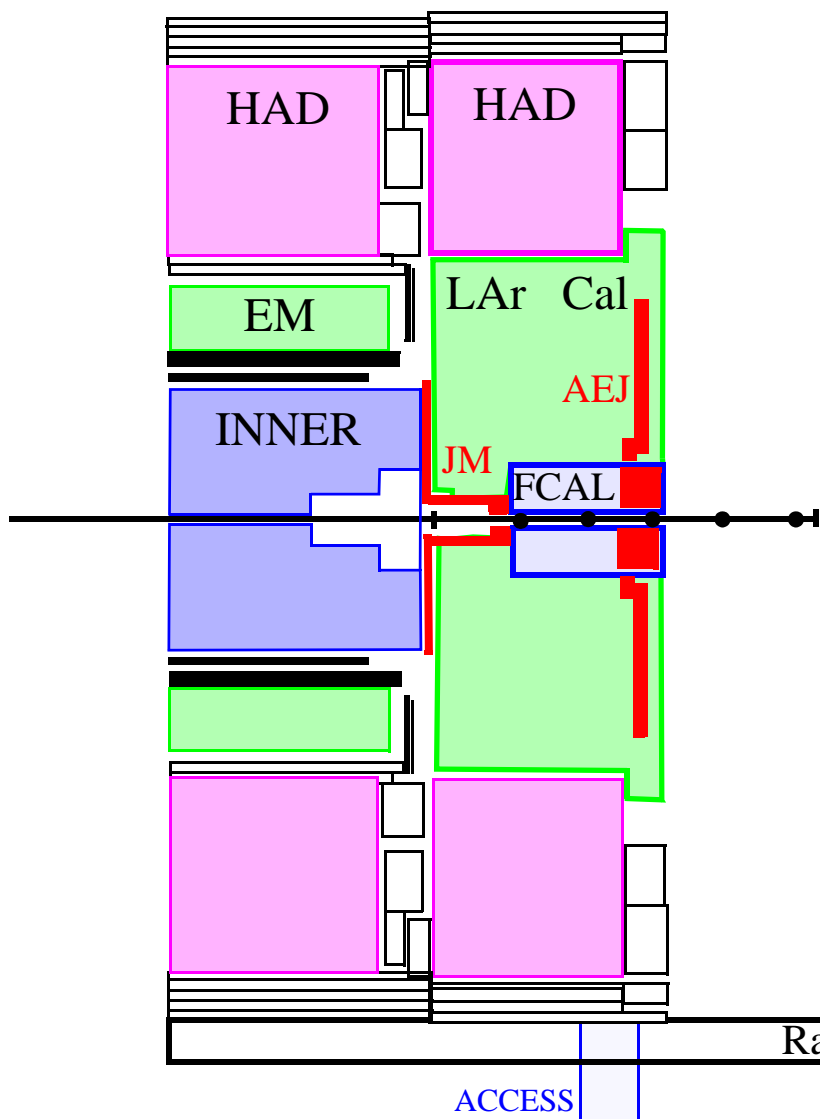

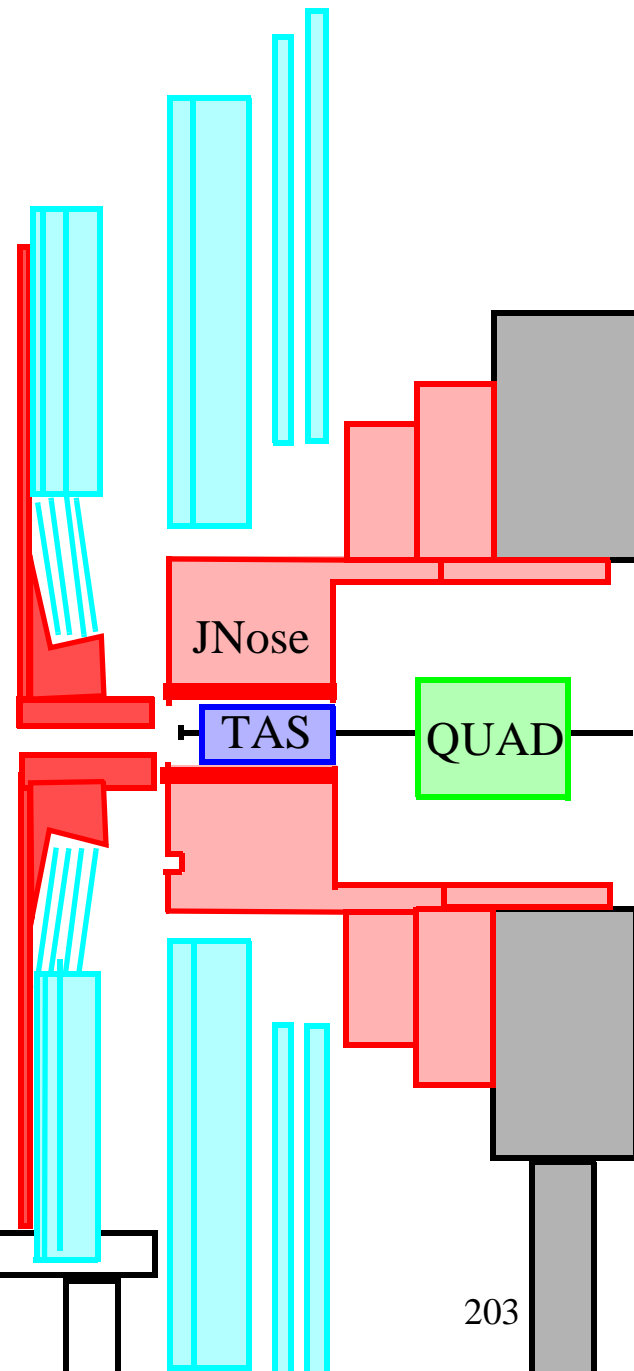
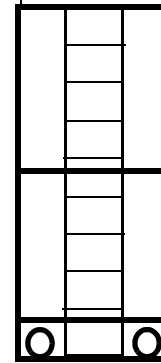
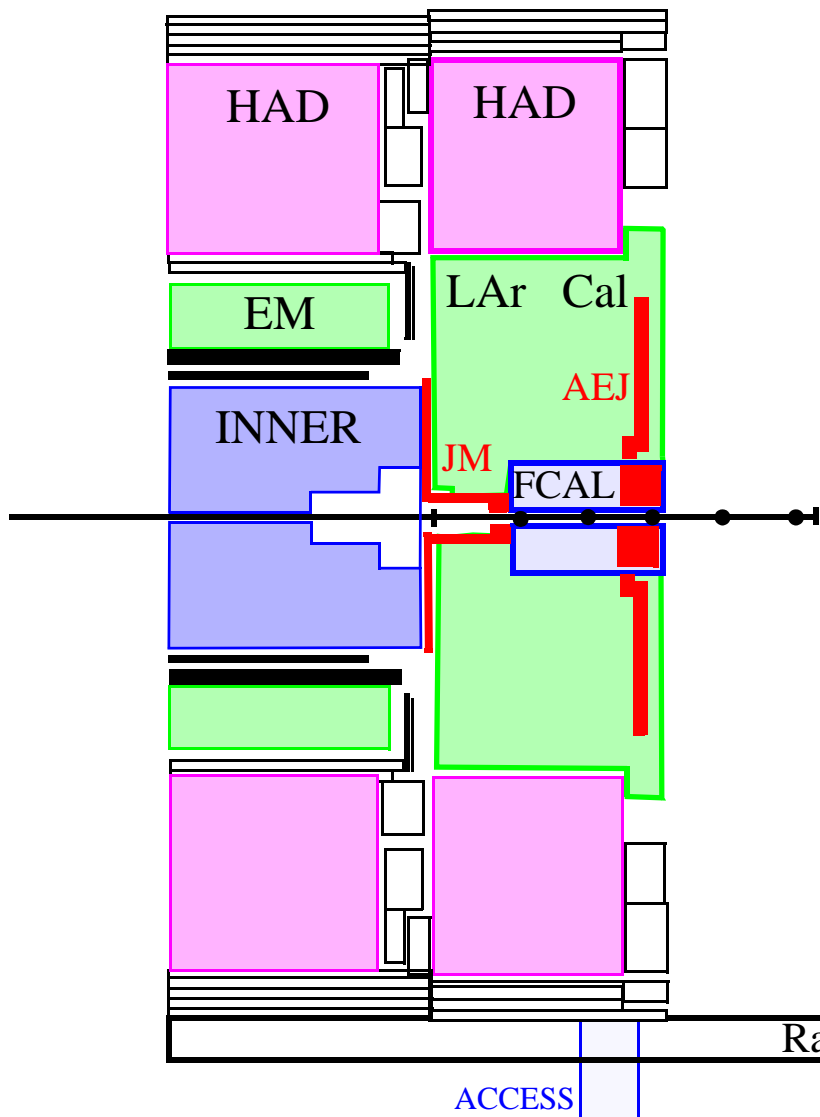

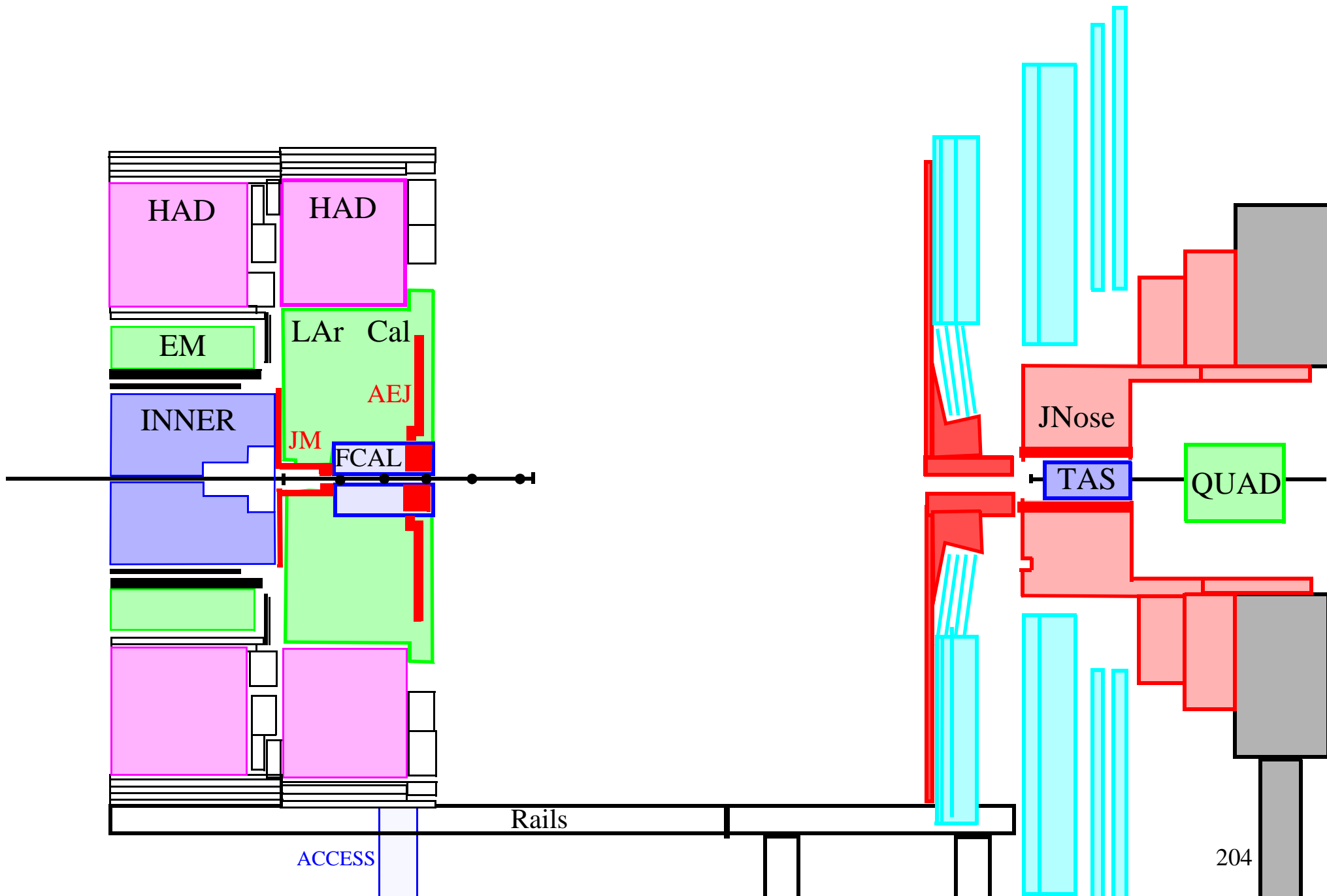

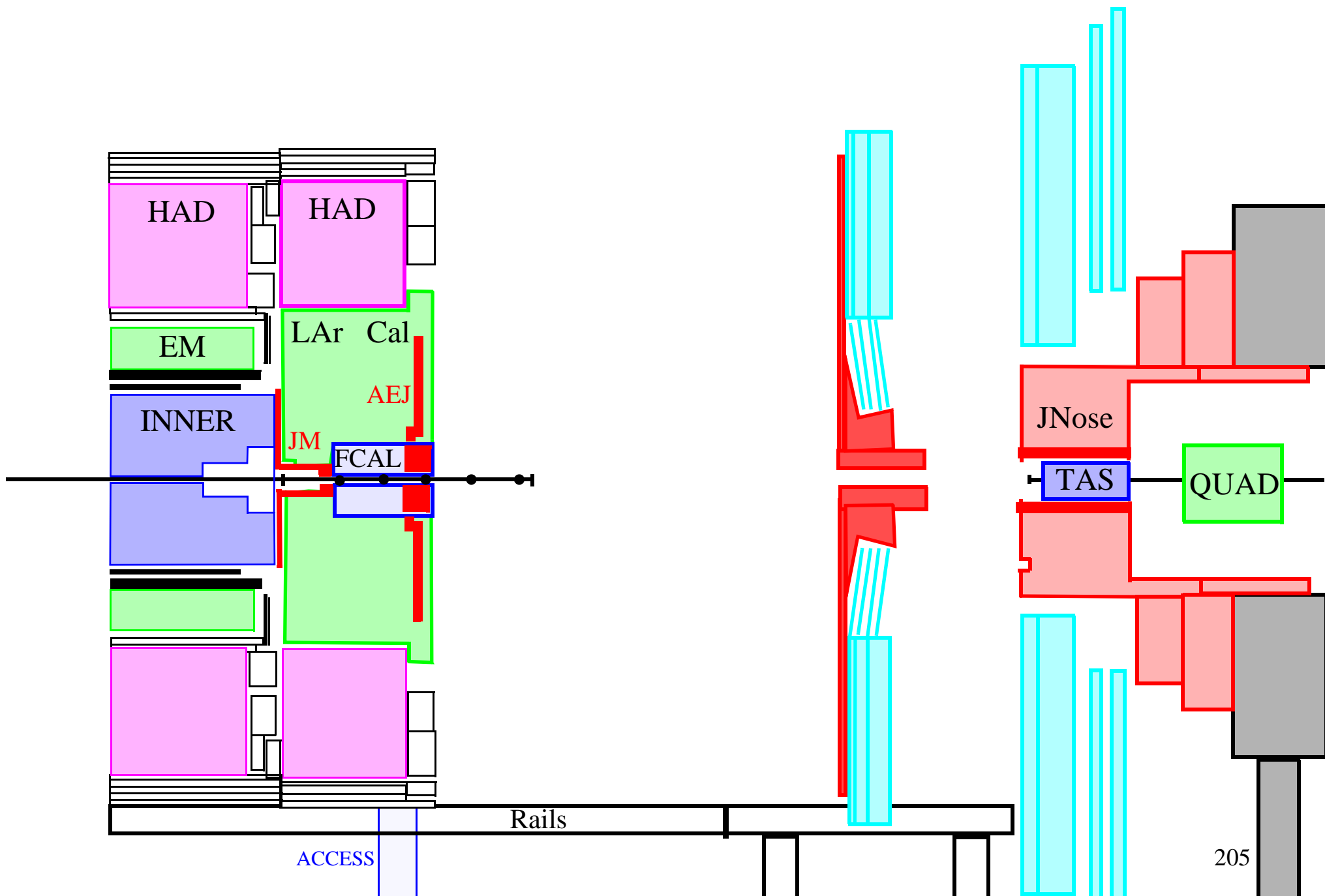

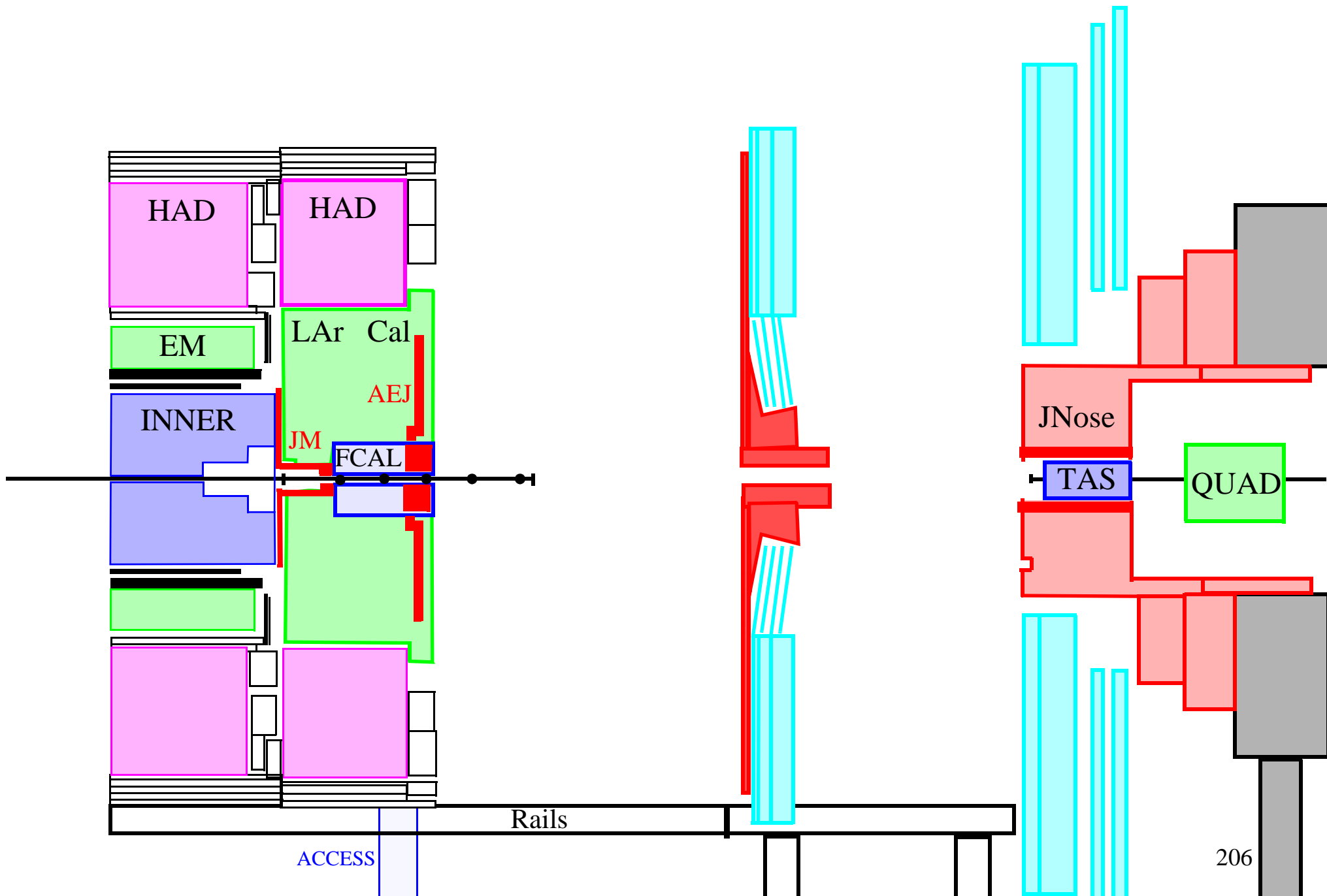

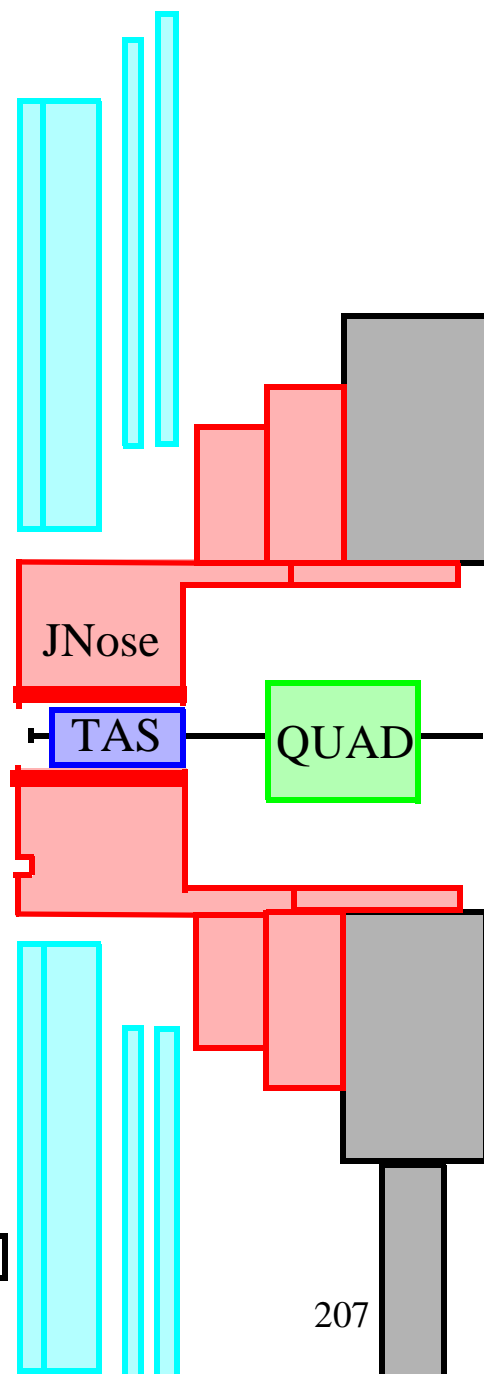
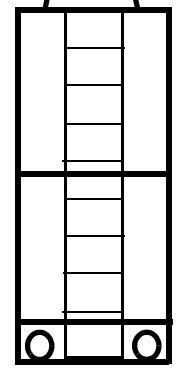
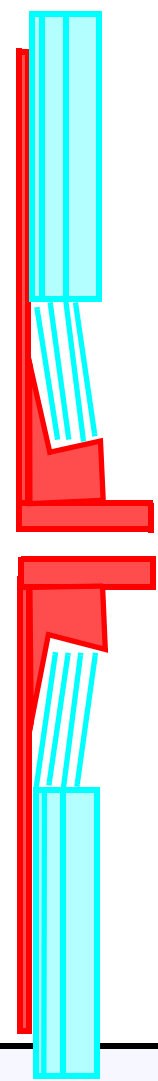
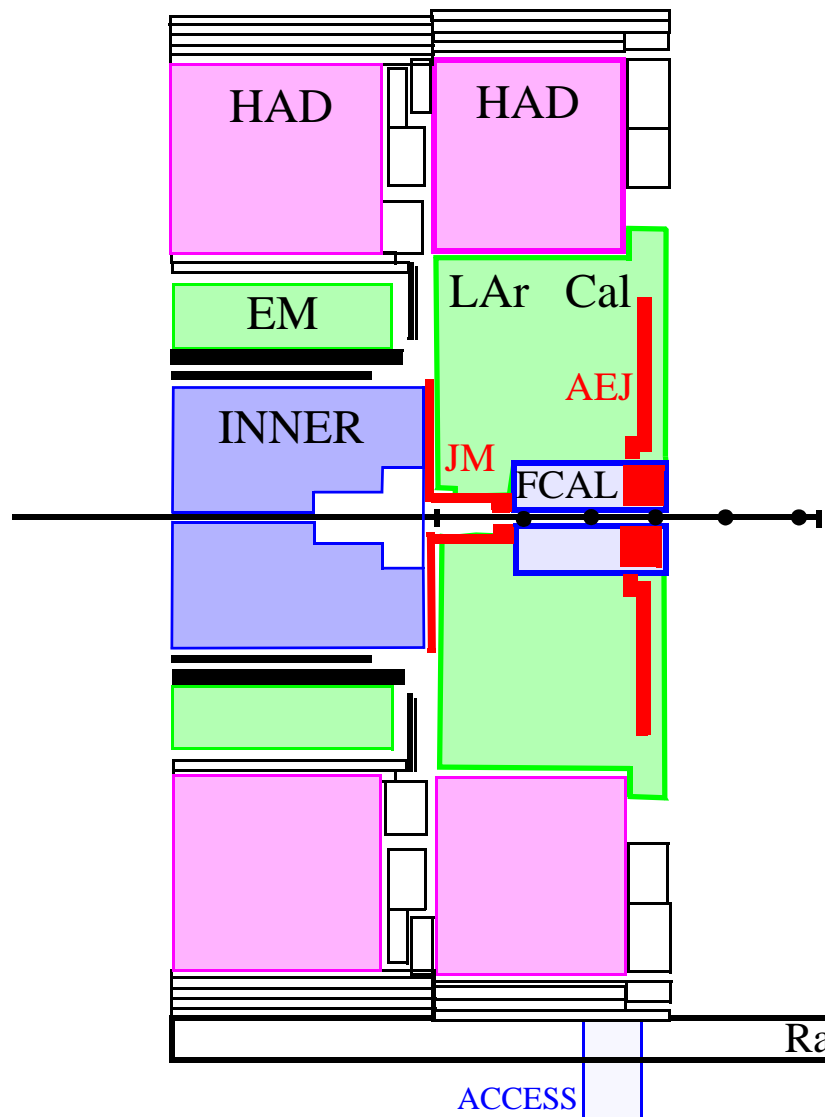

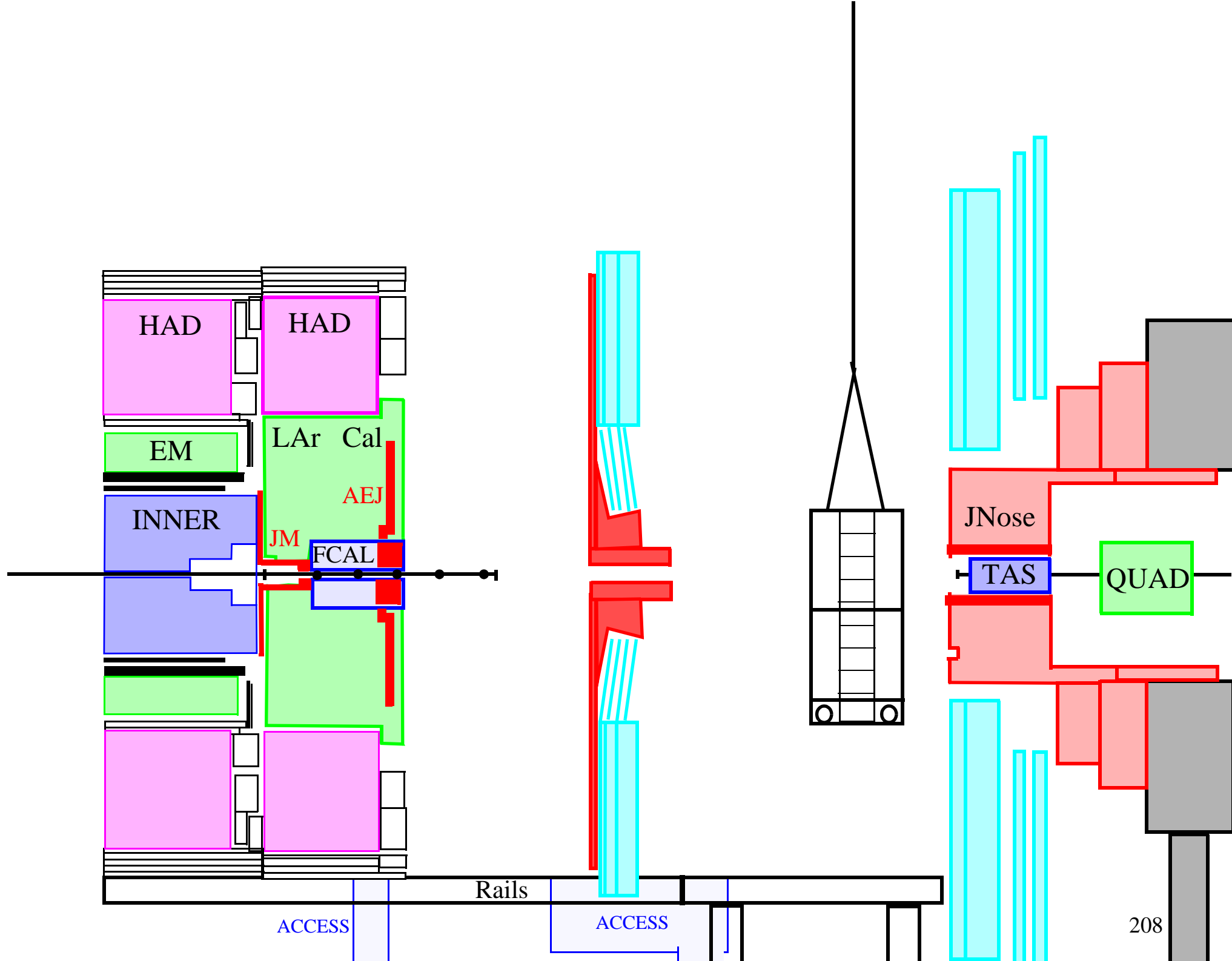

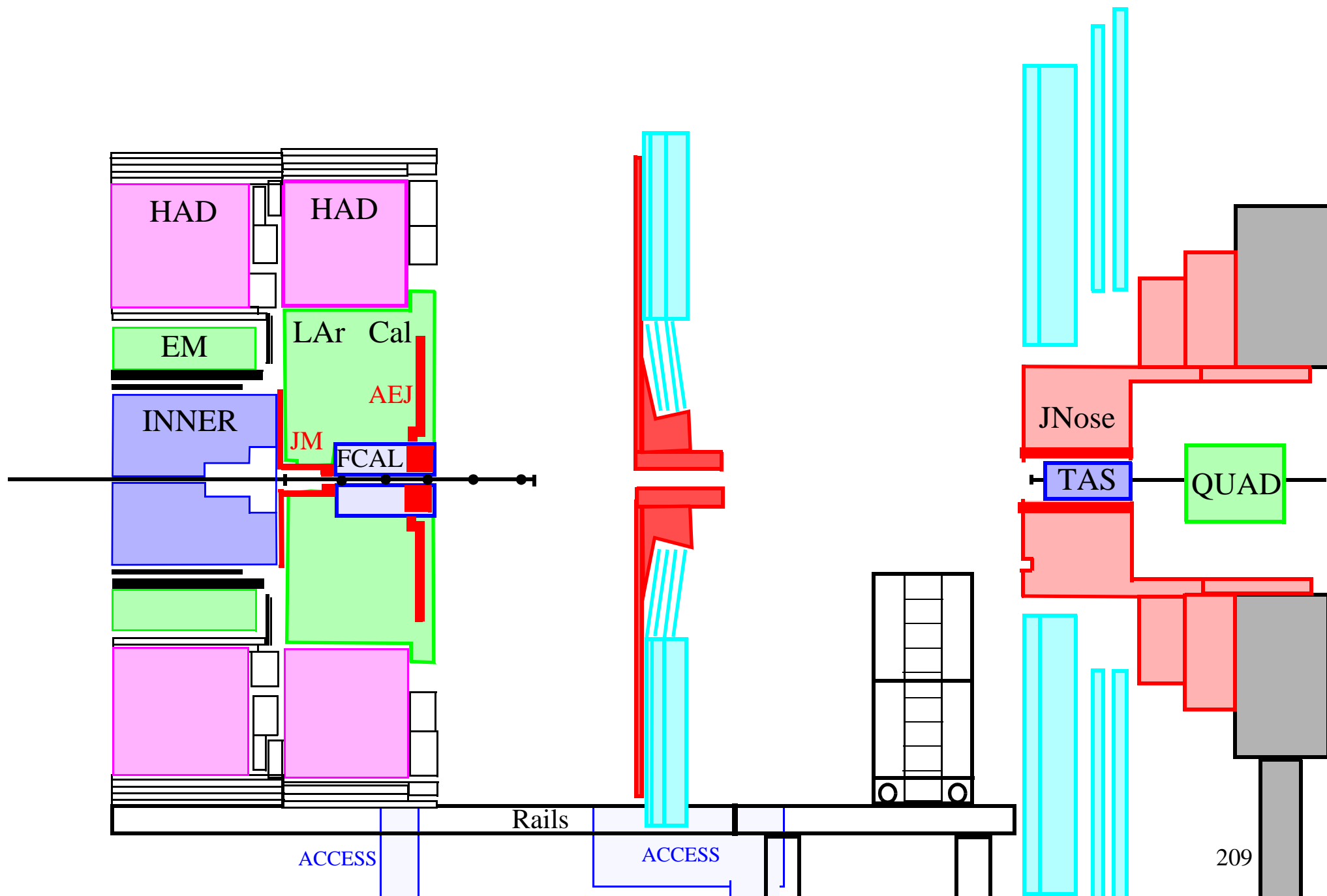

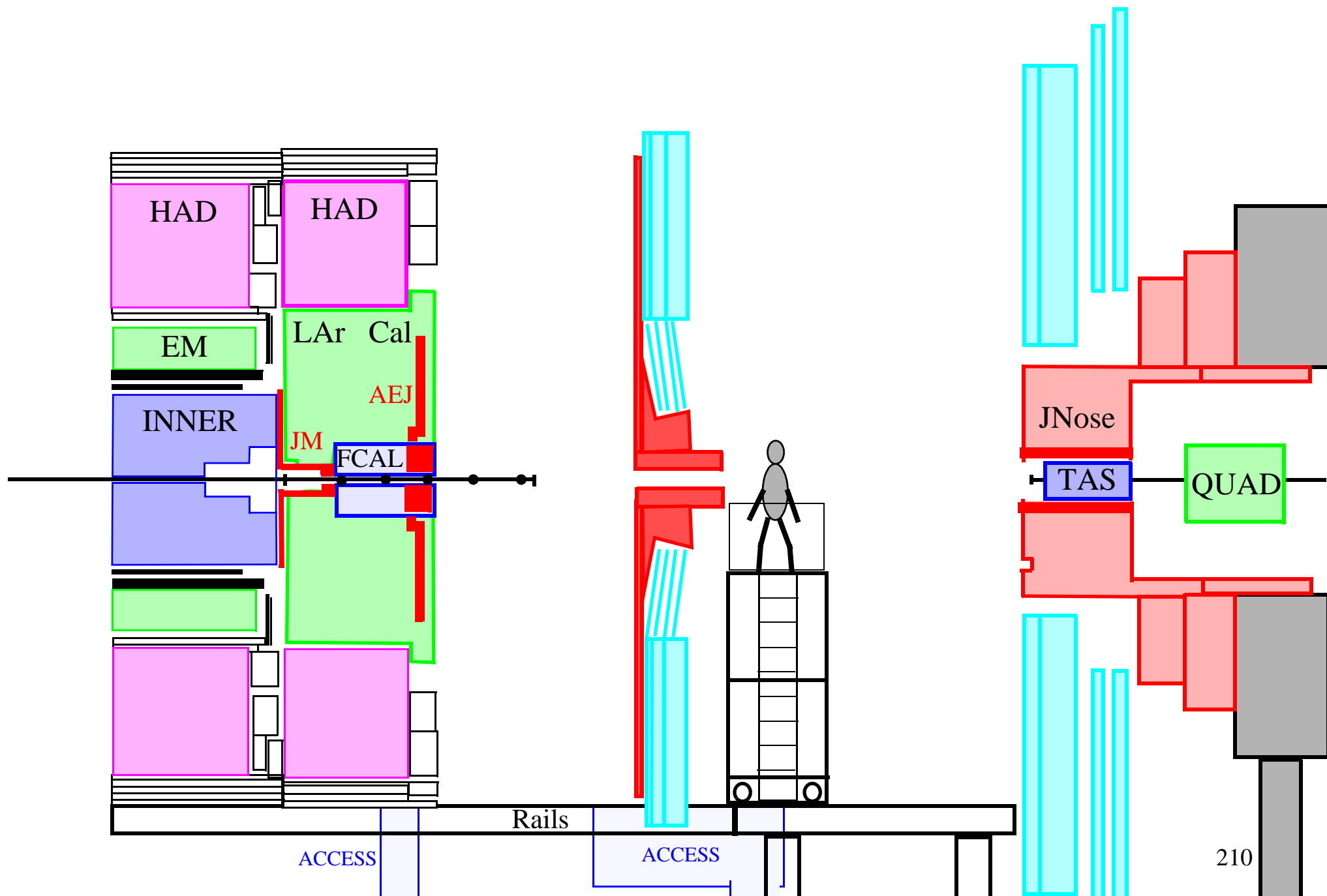

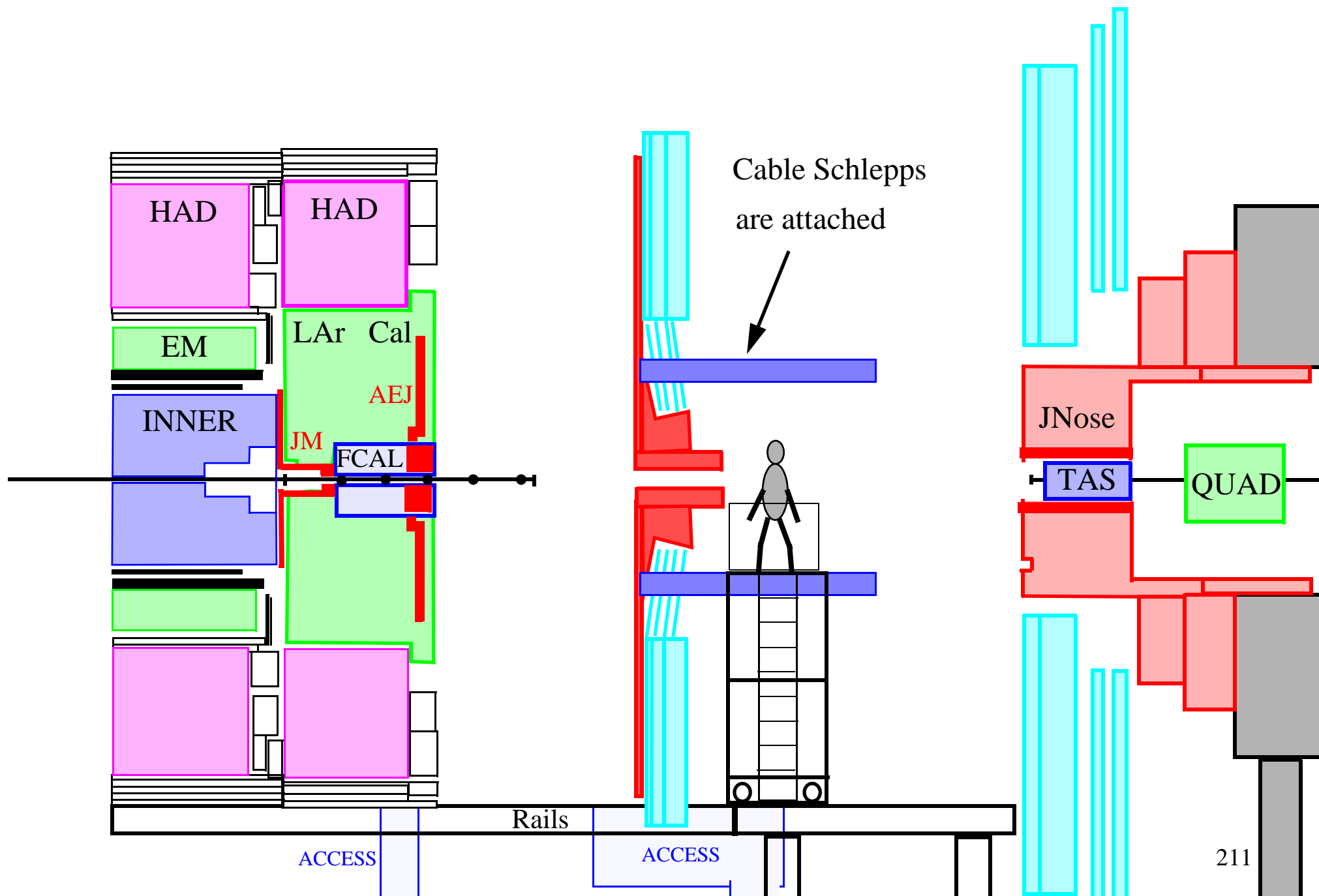

SERVICES TRAYS

MDT ROUTING

Cable Schlepps

CSC ROUTING

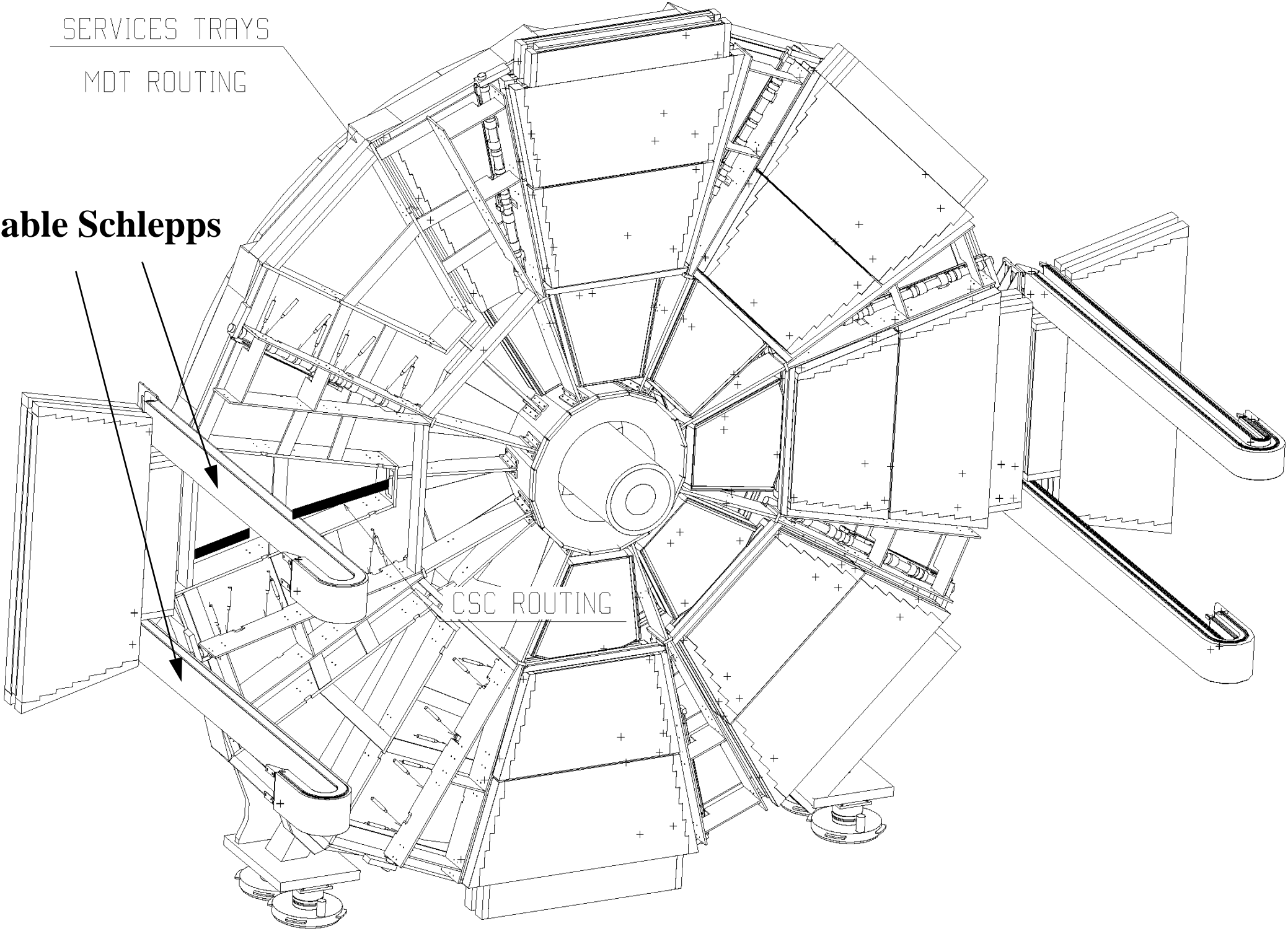

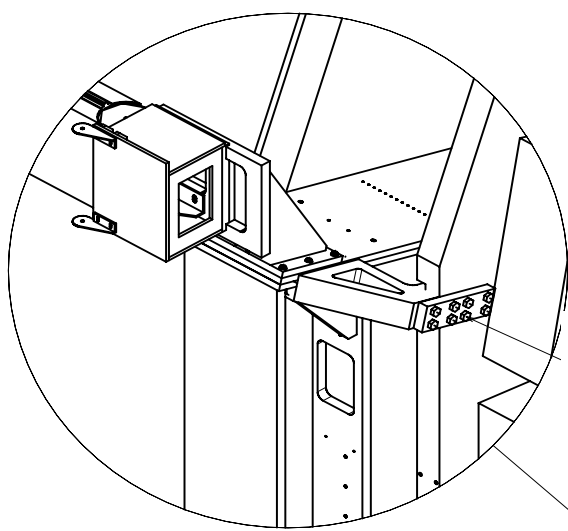

3 attachments
to the SW

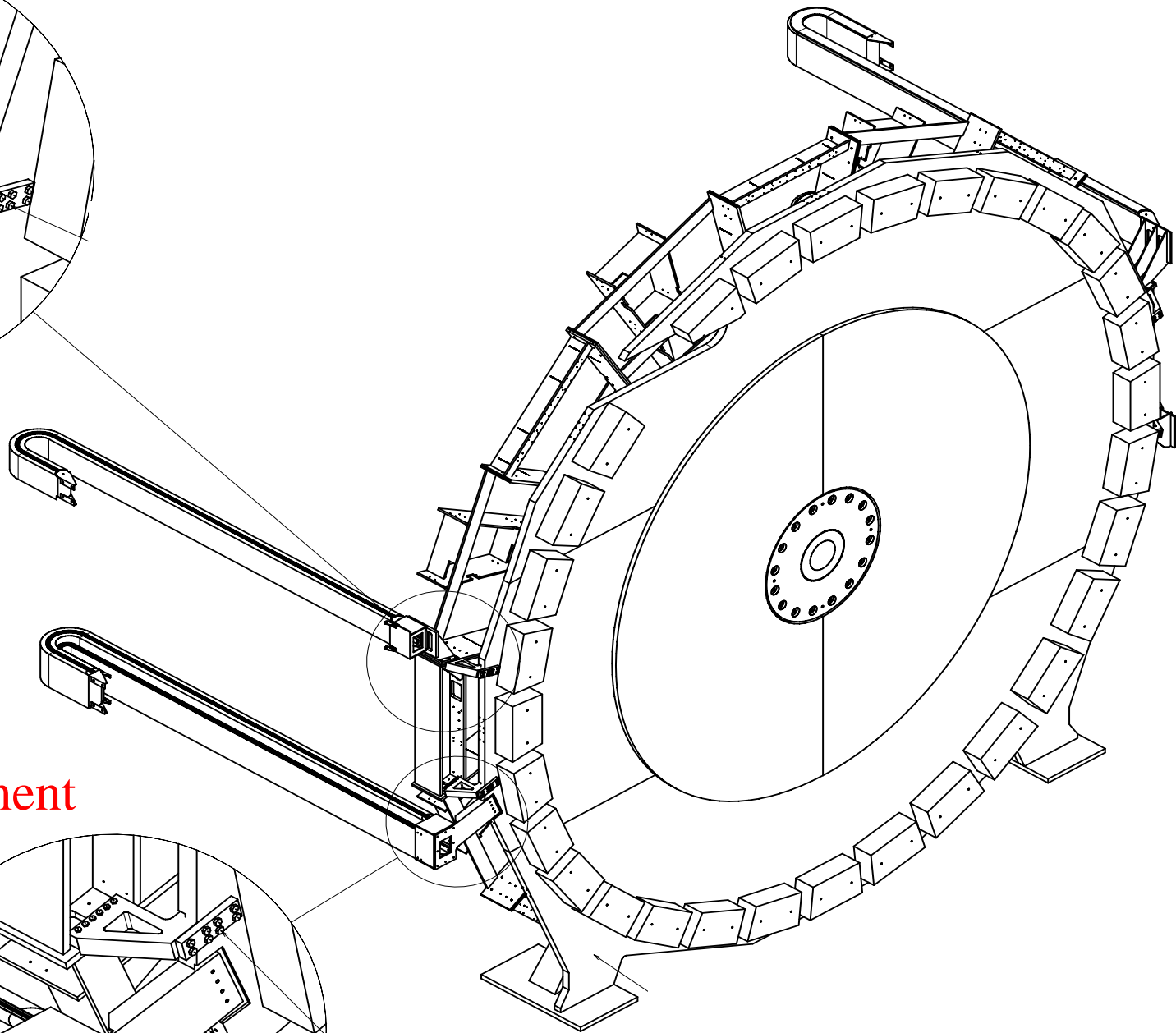

One attachment
to the JD.

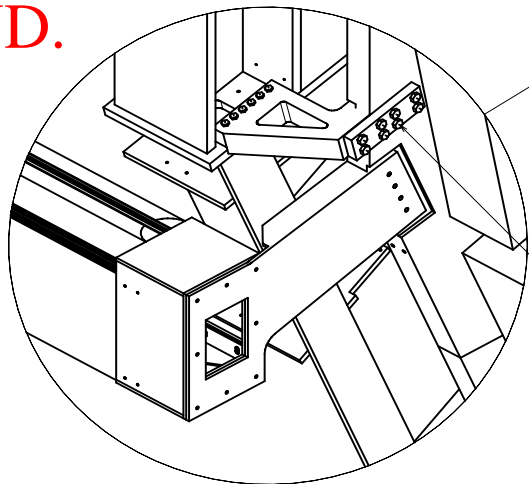

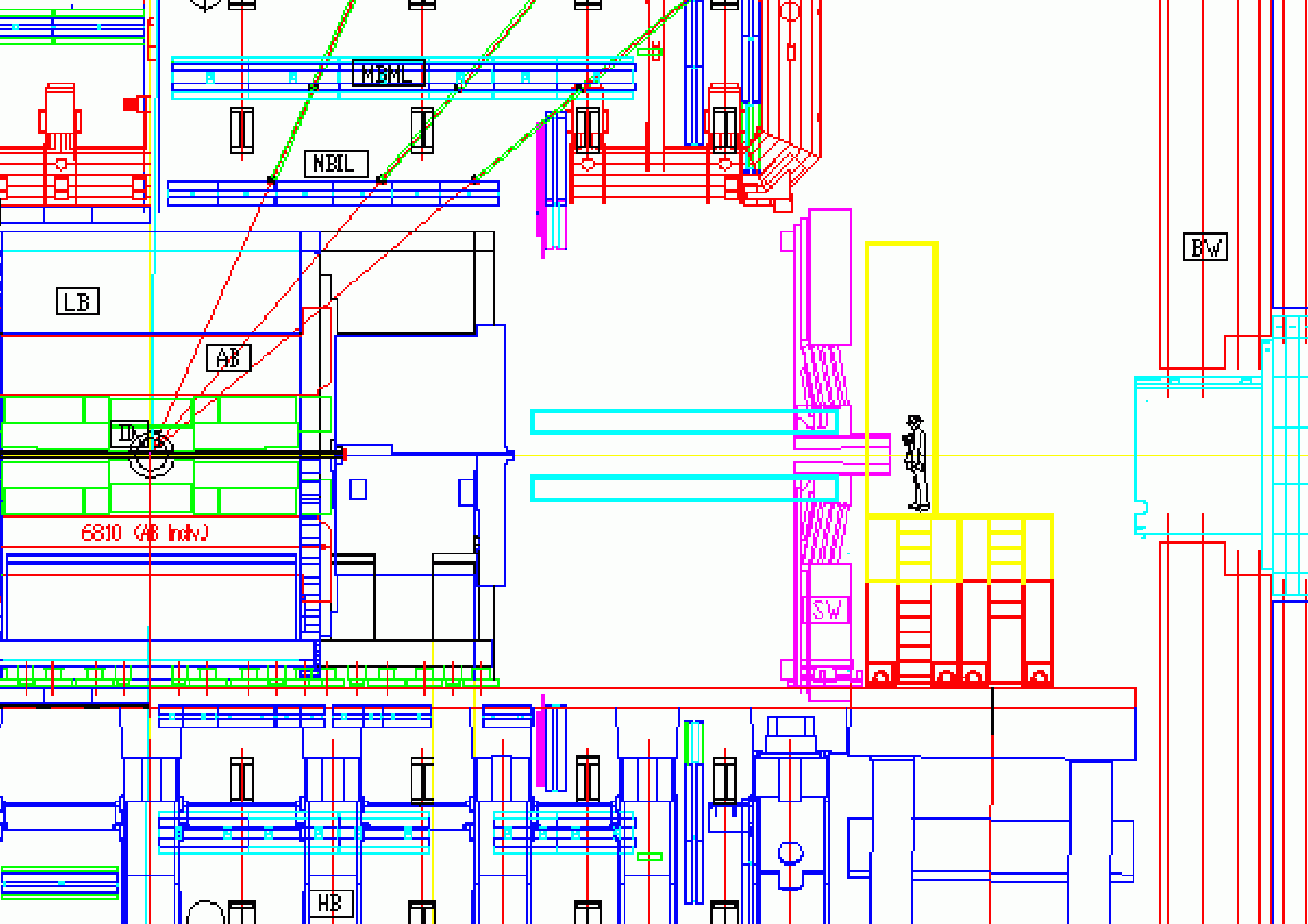

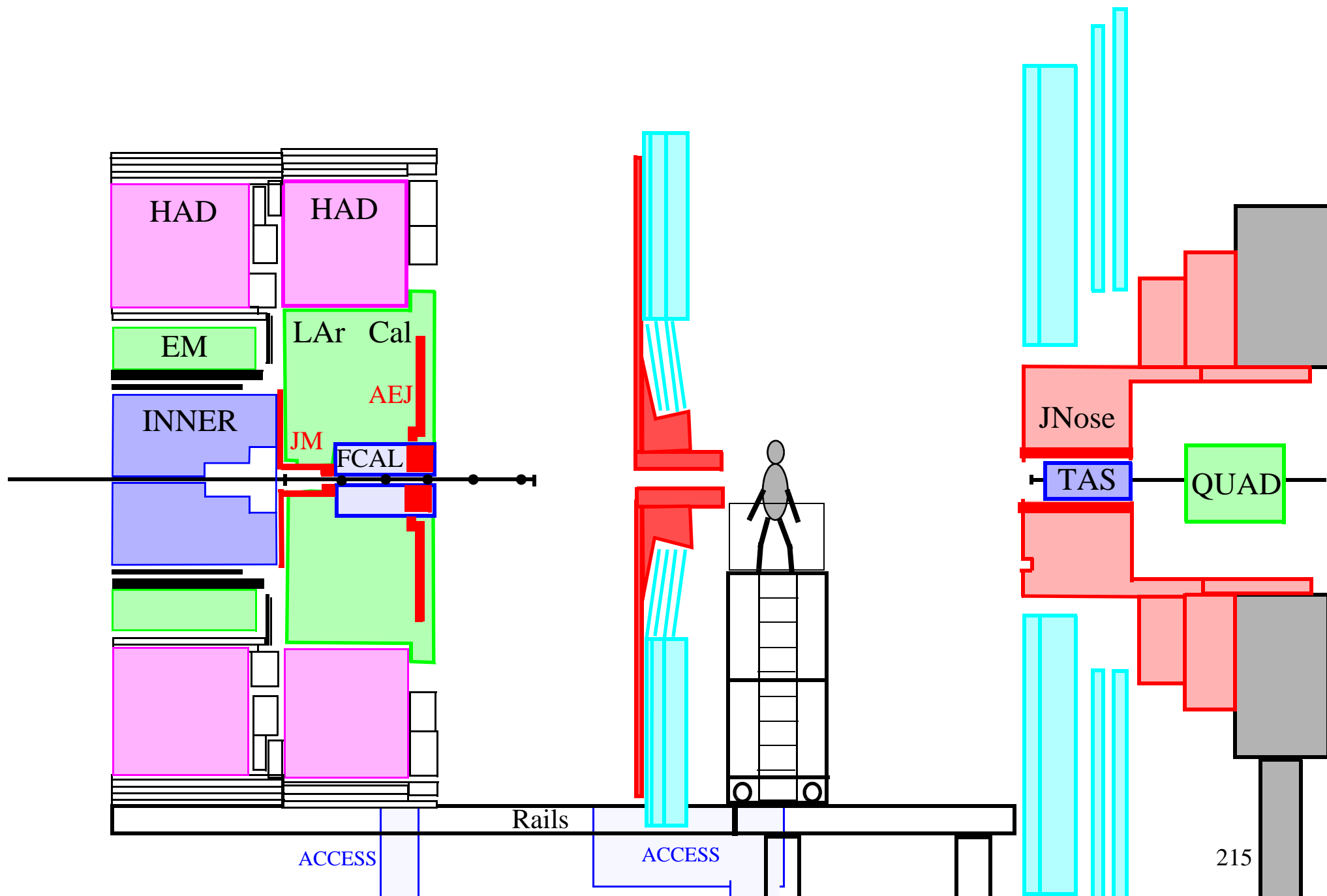

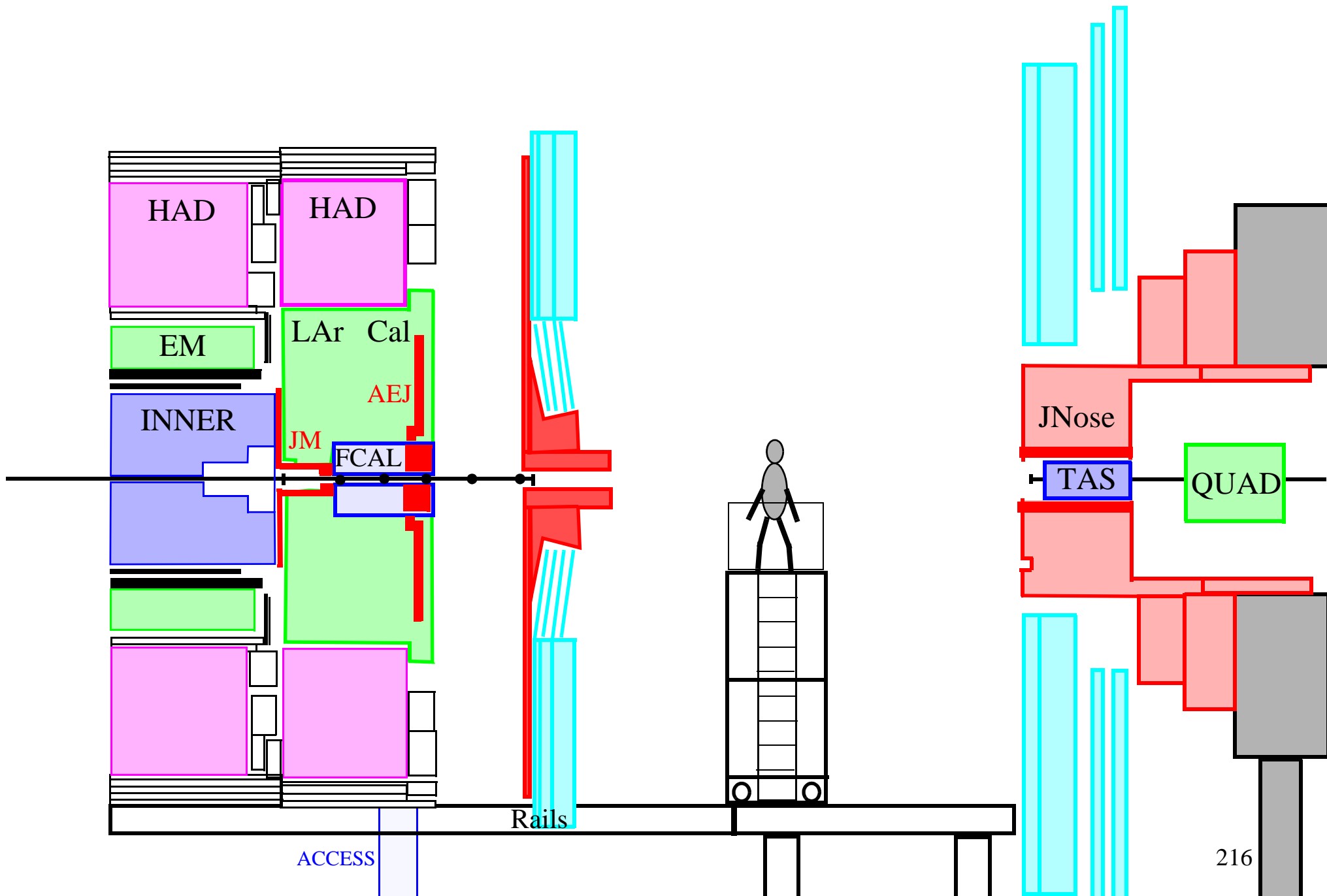

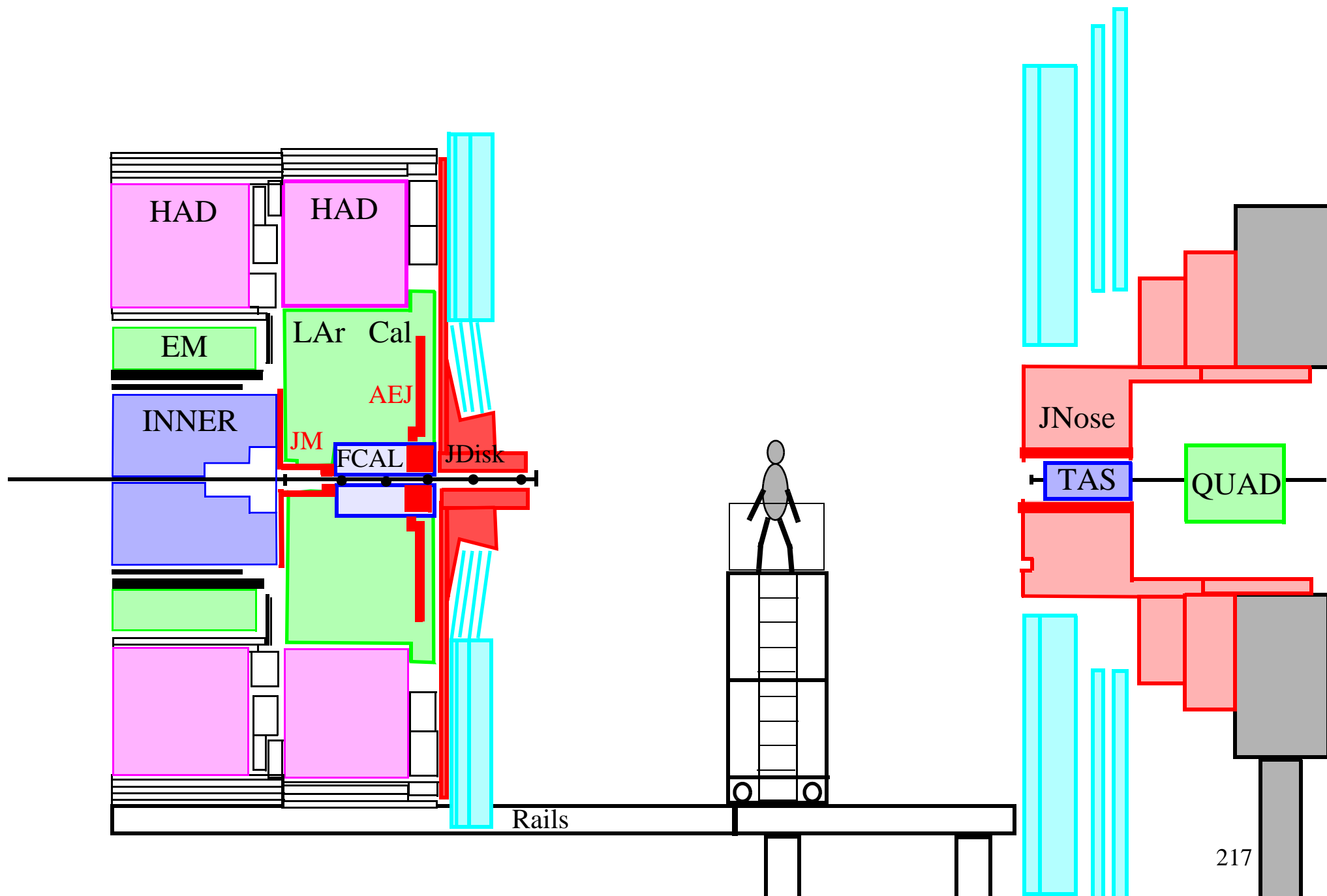

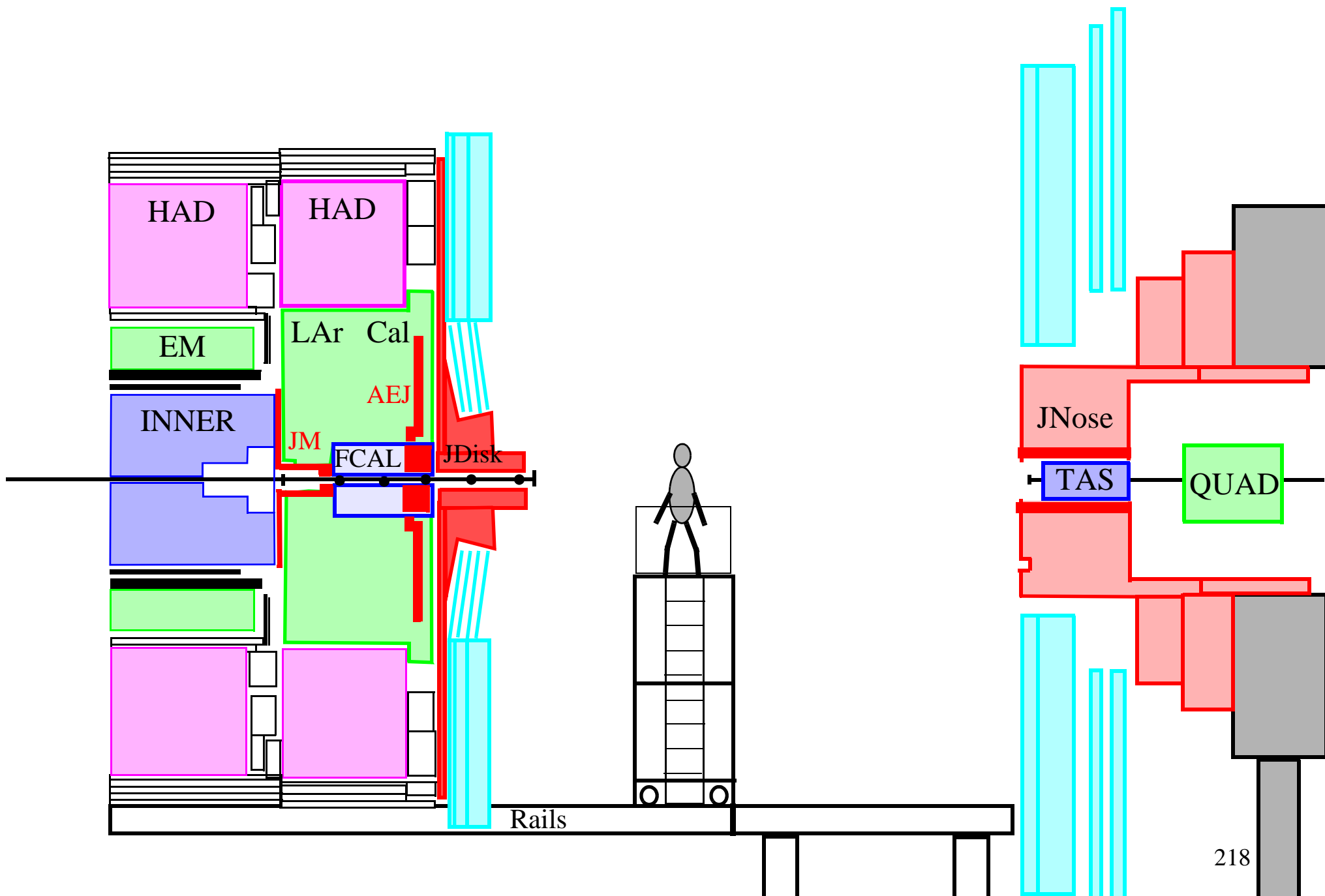

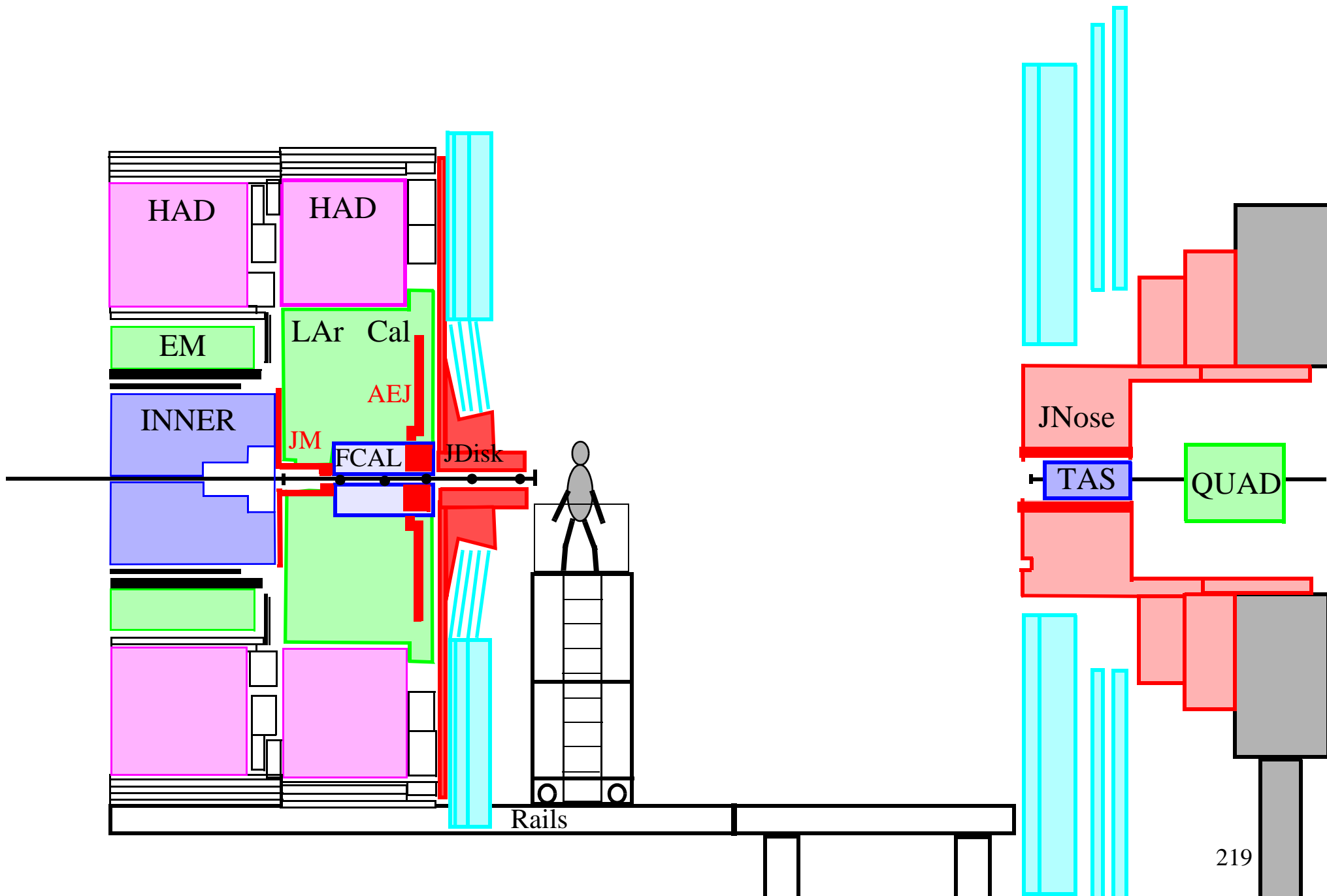

Beampipe supports

This support has to be attached.

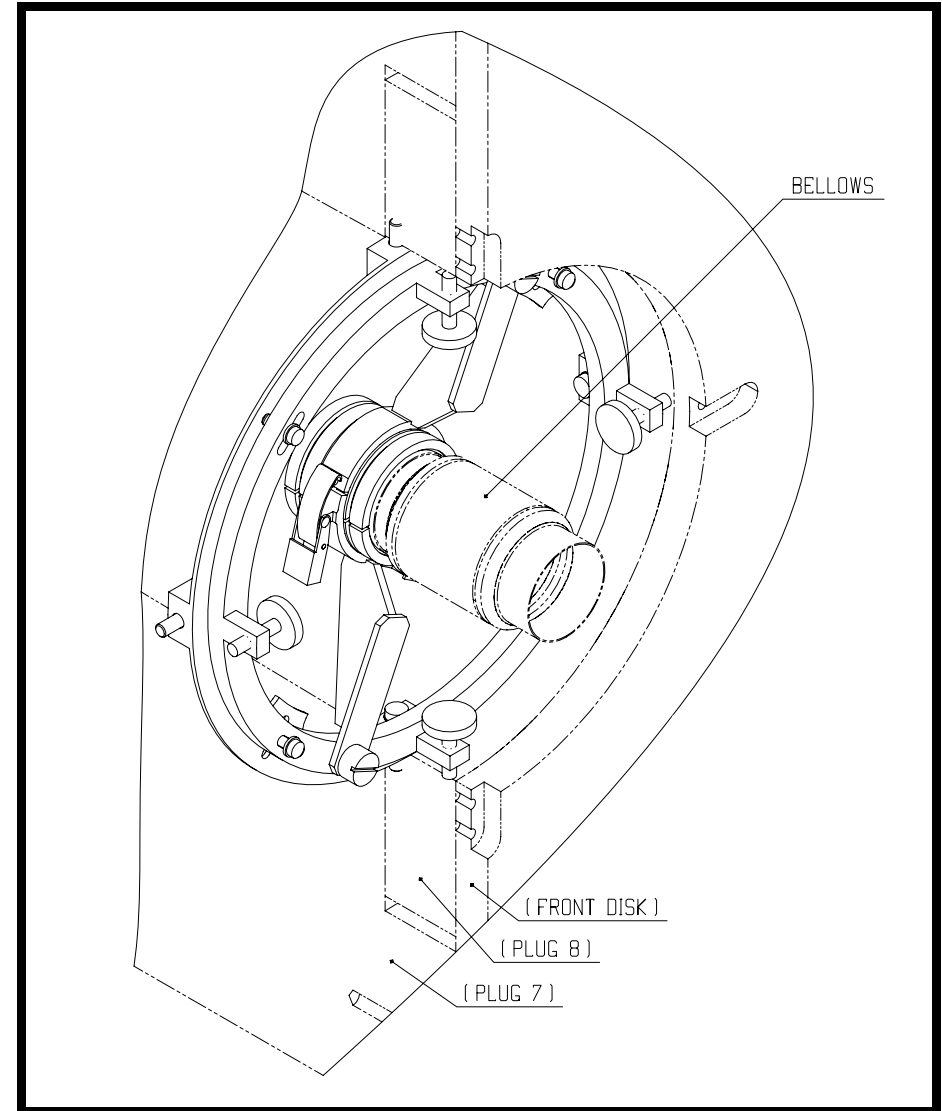
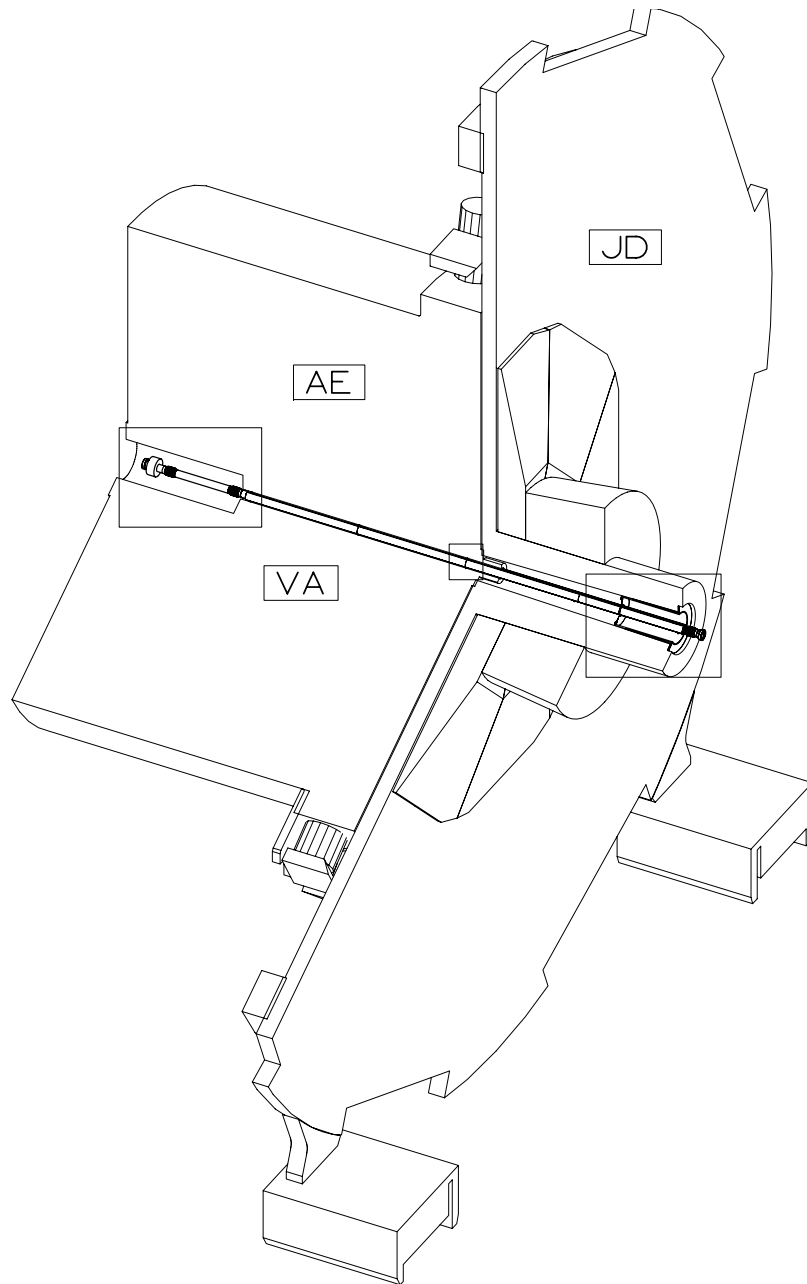

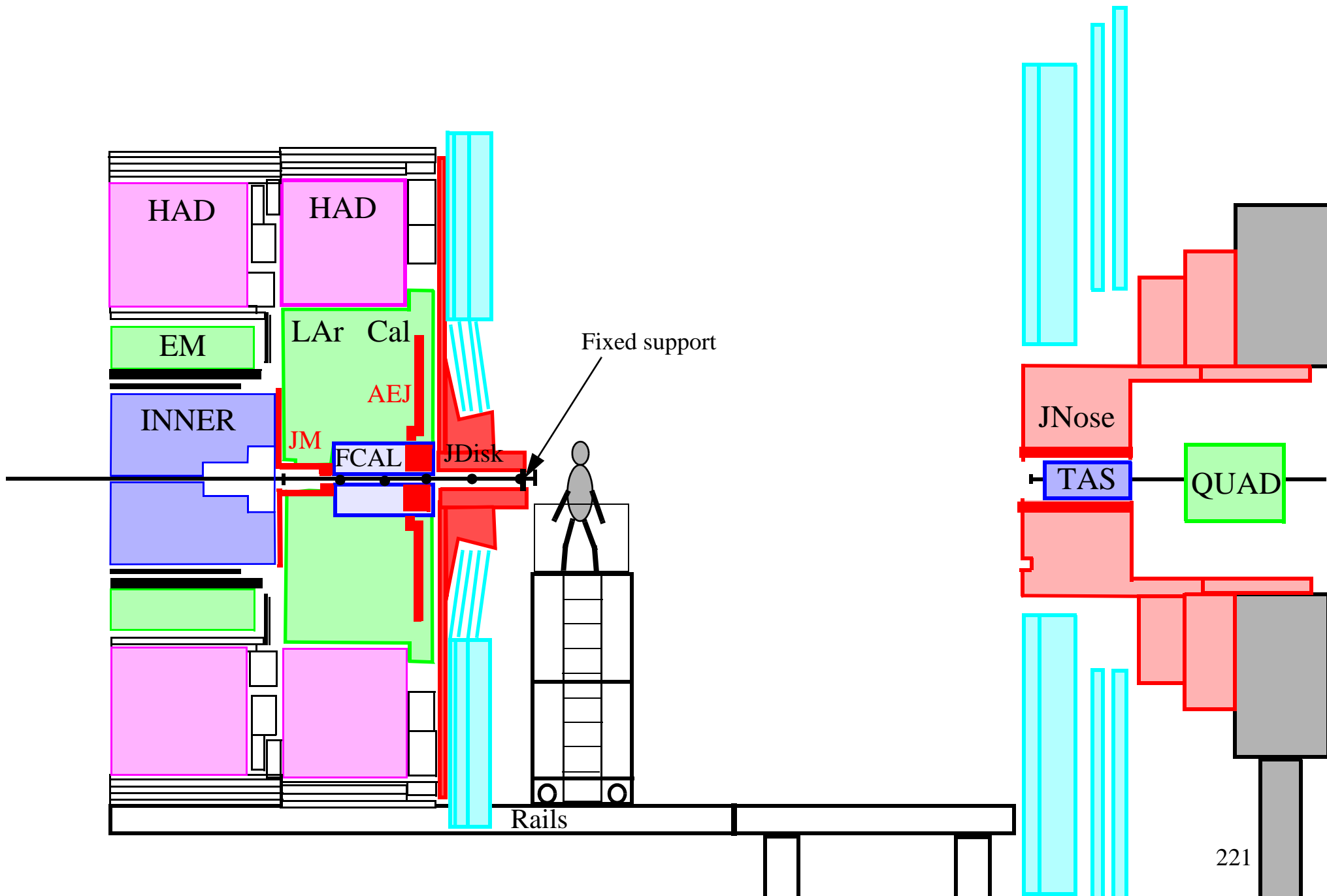

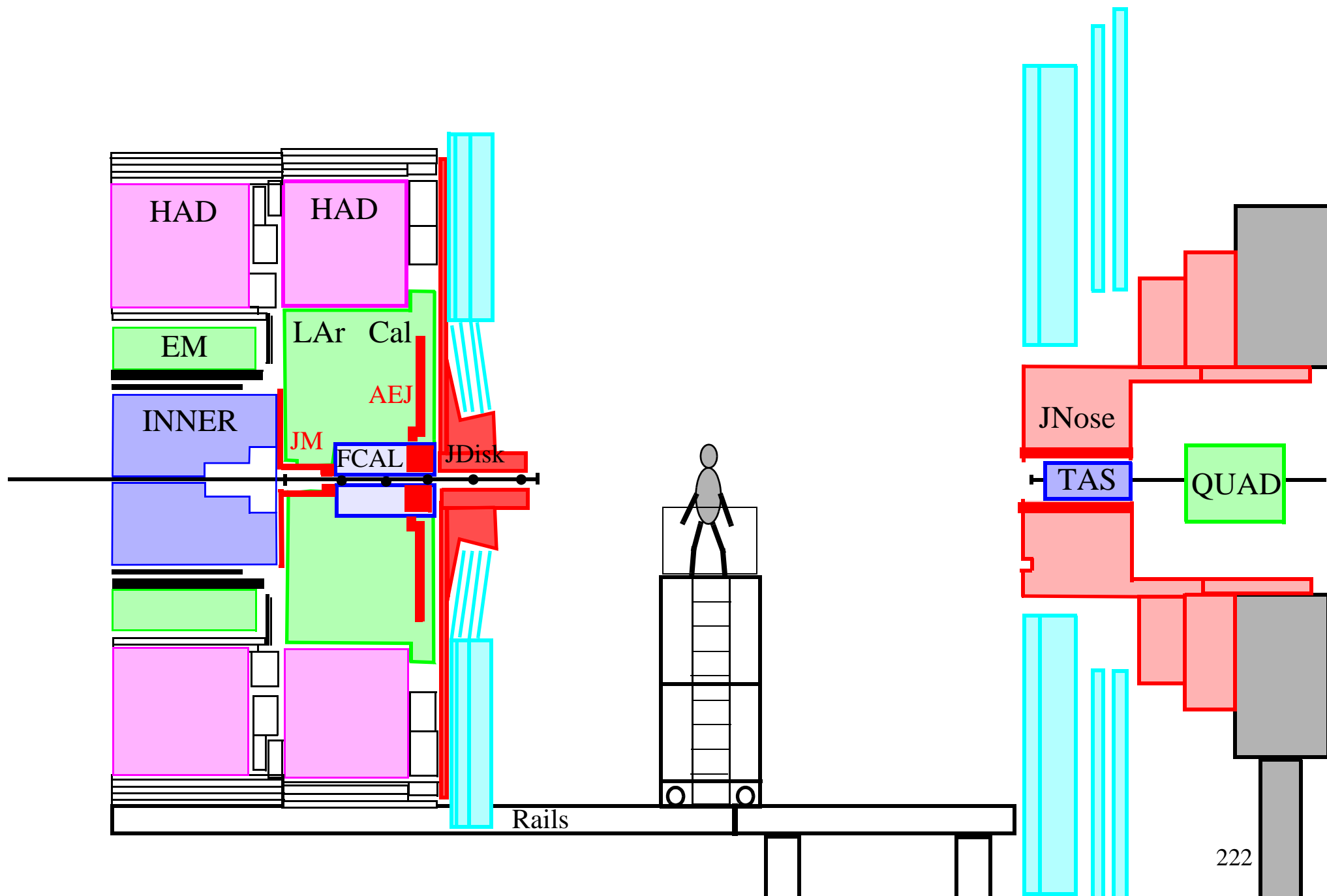

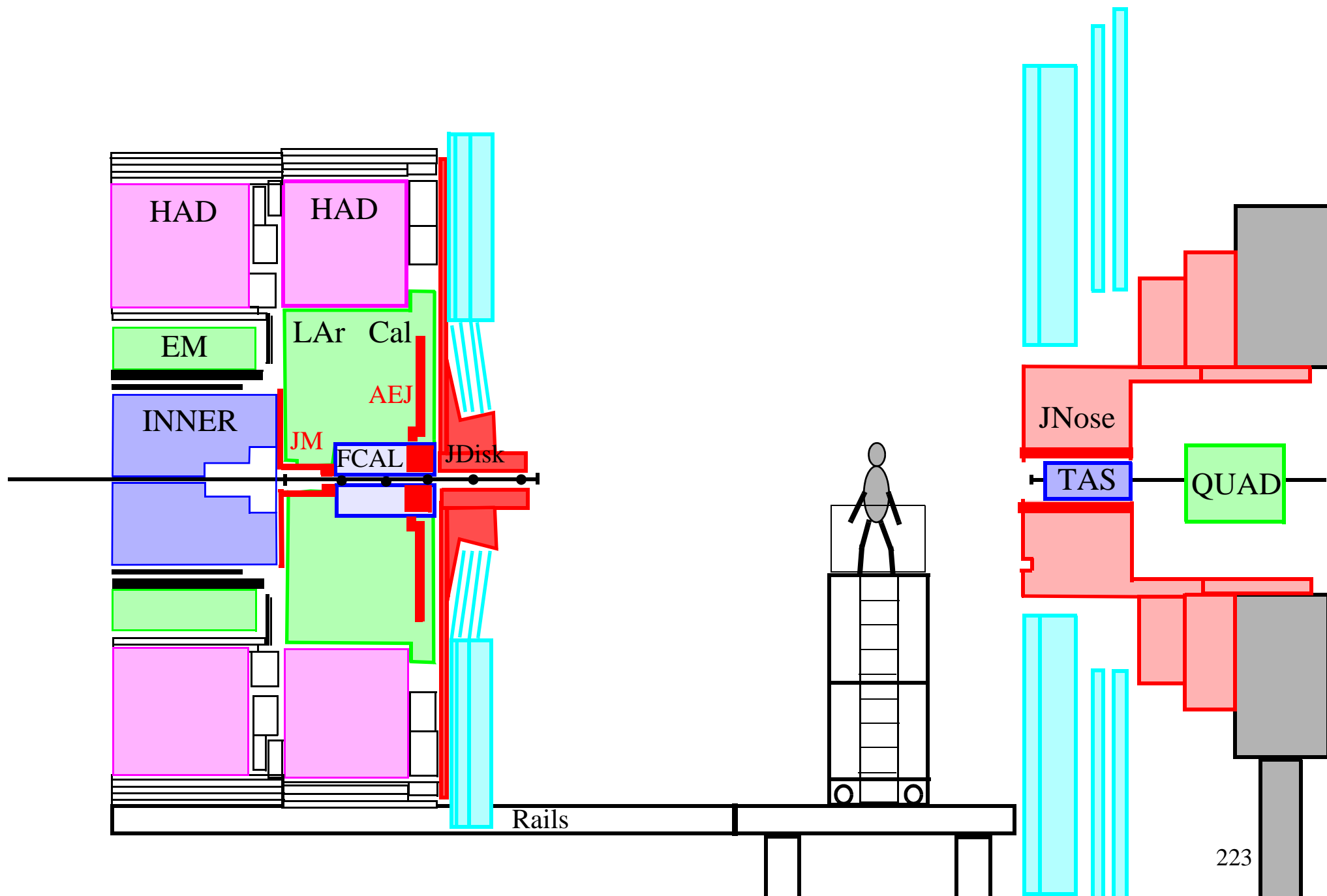

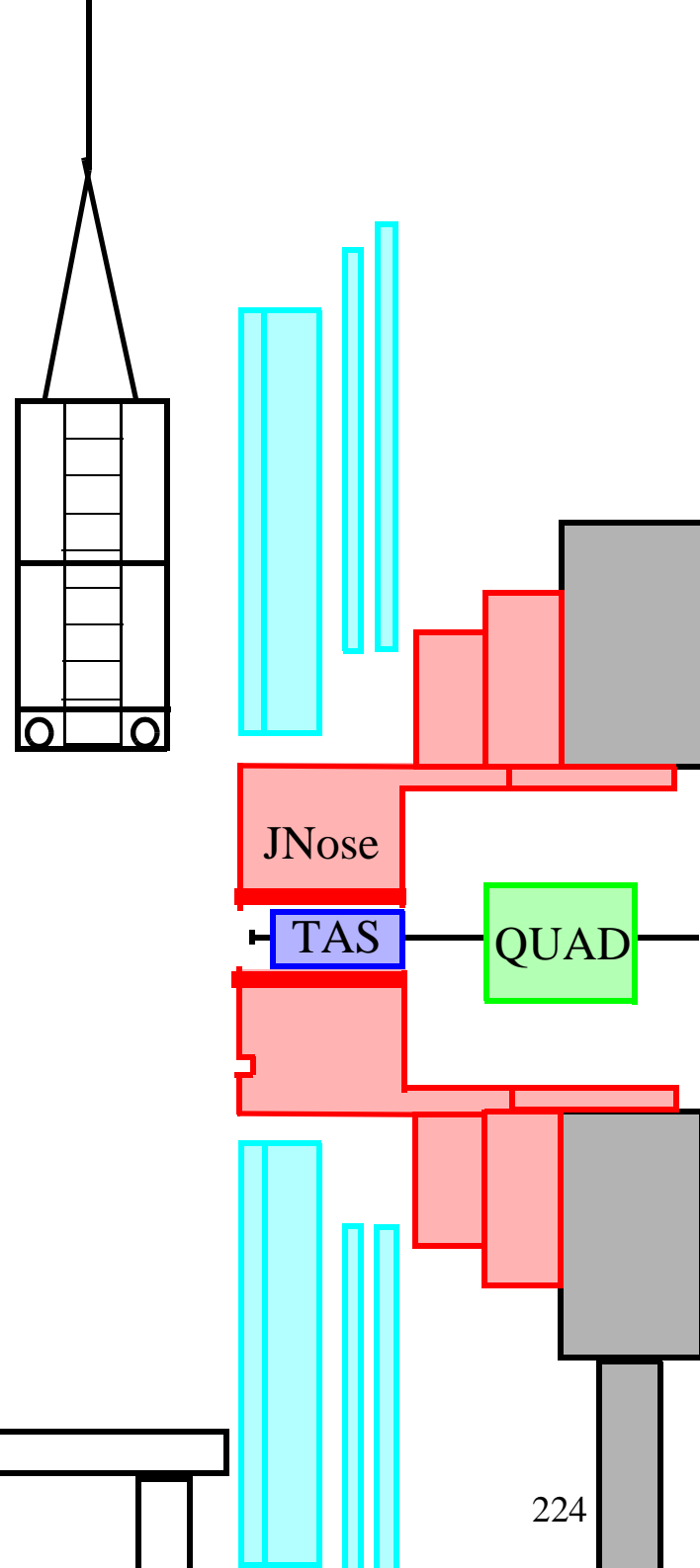
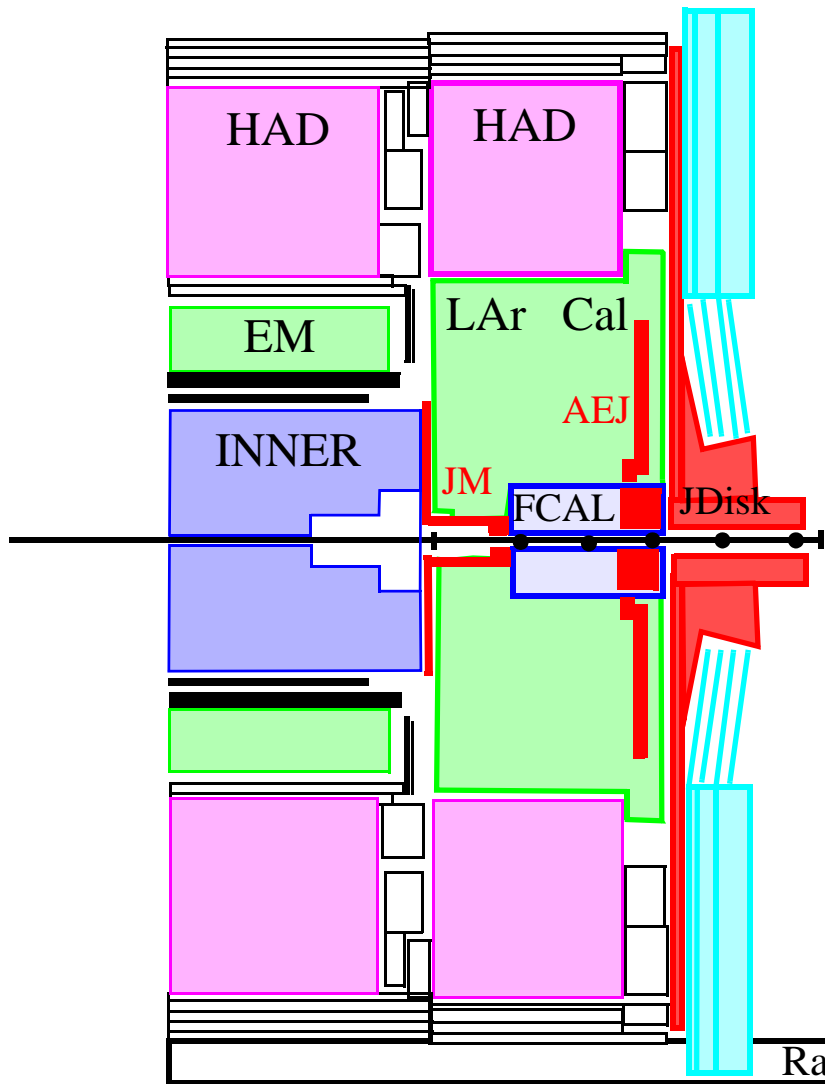

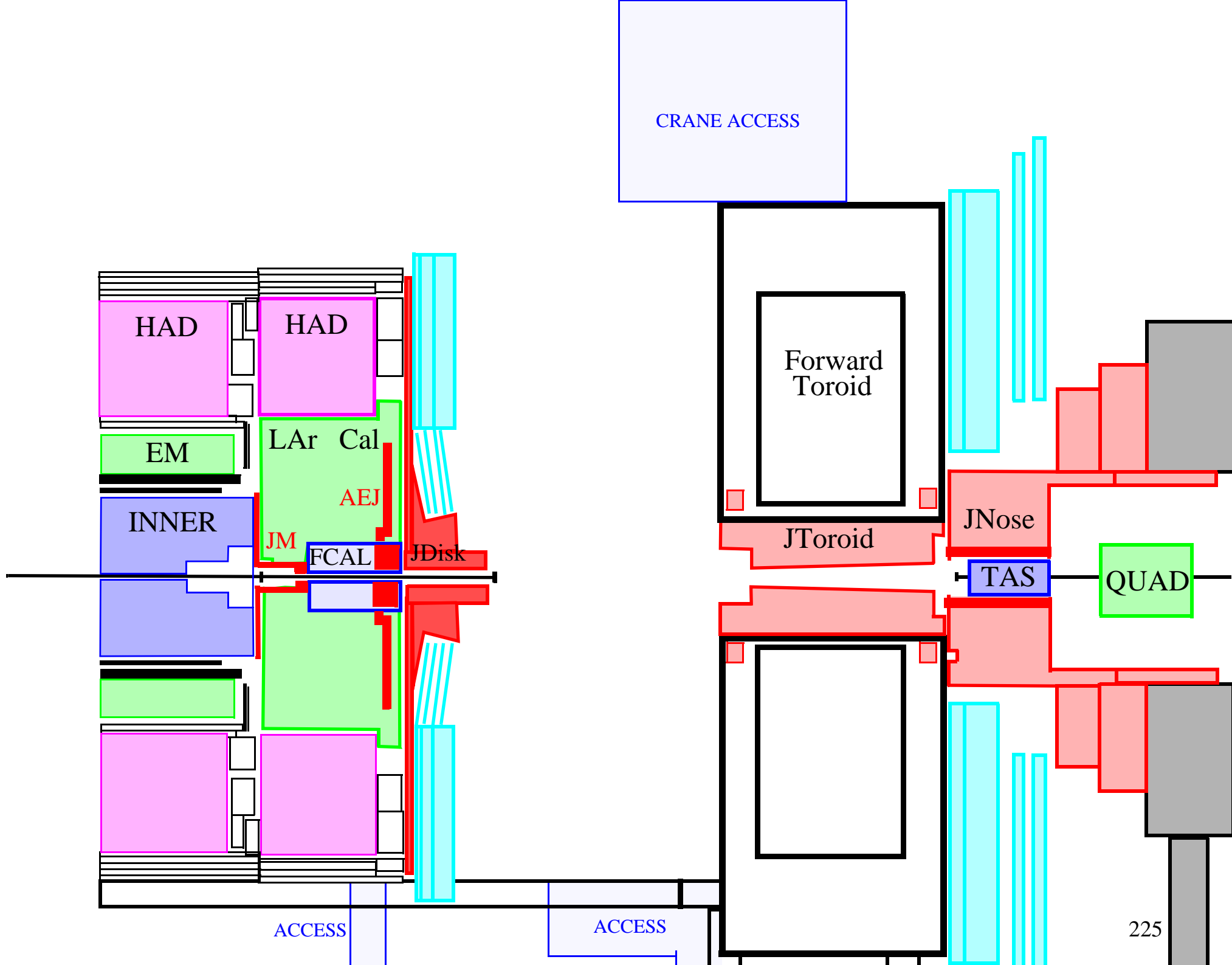

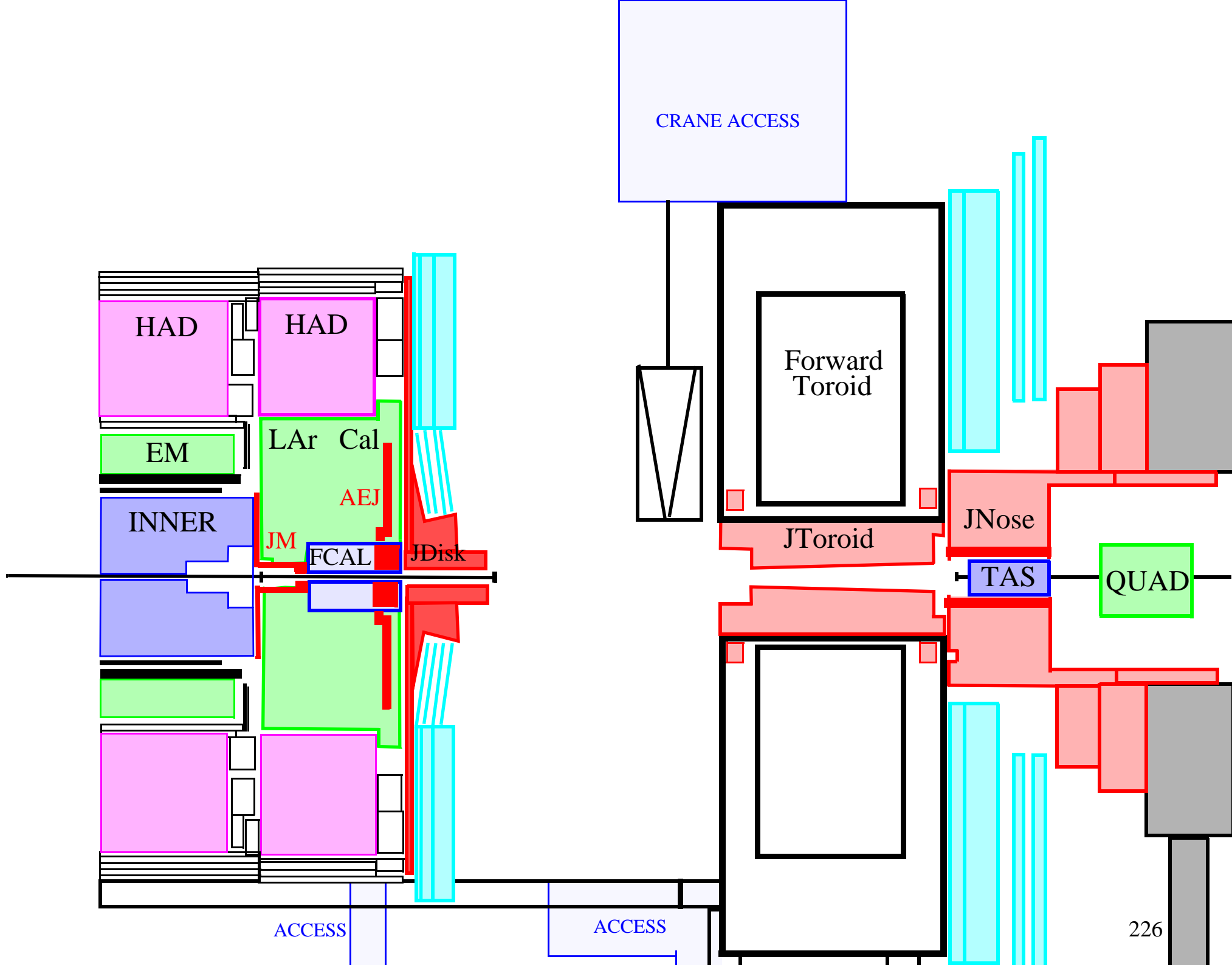

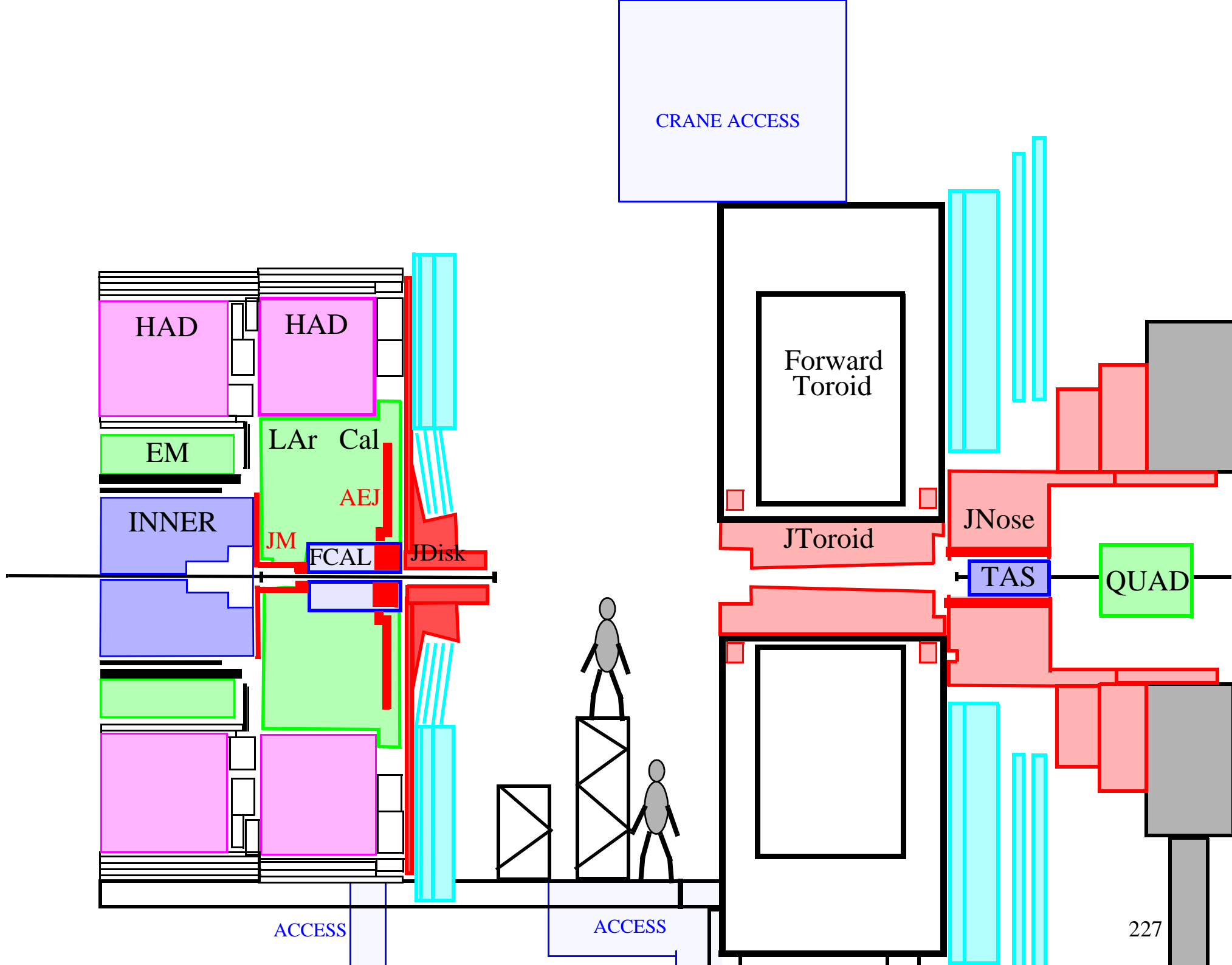

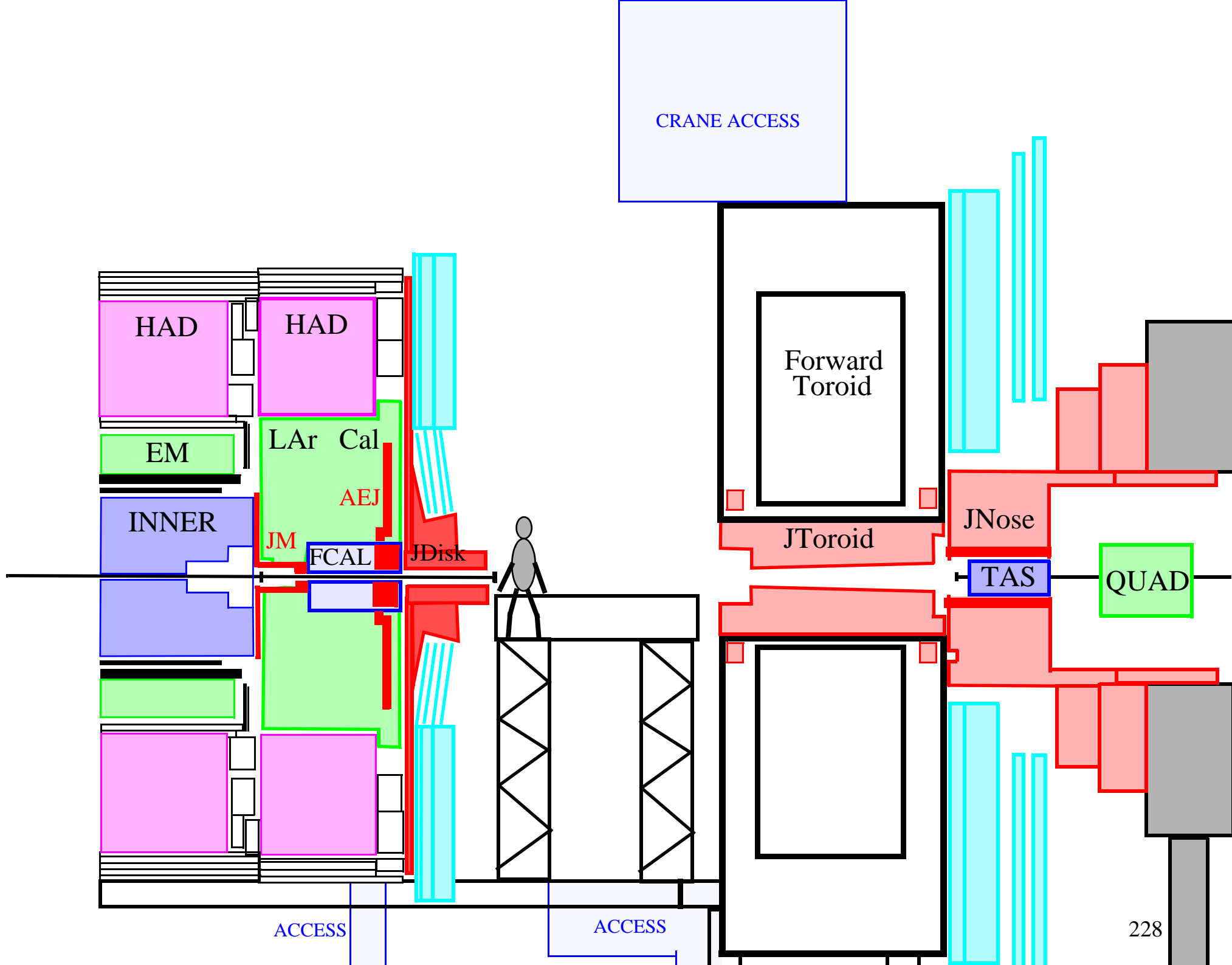

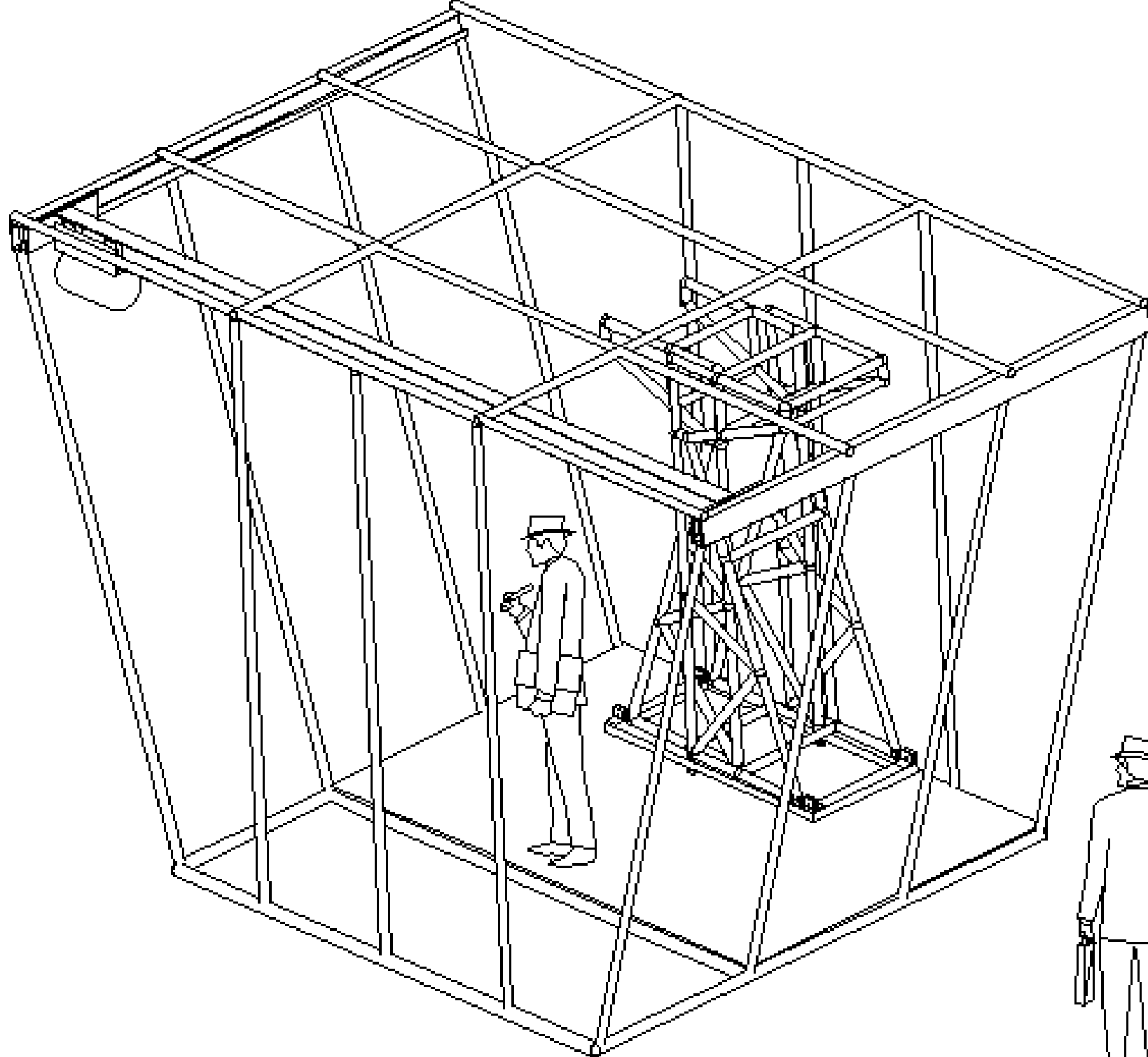

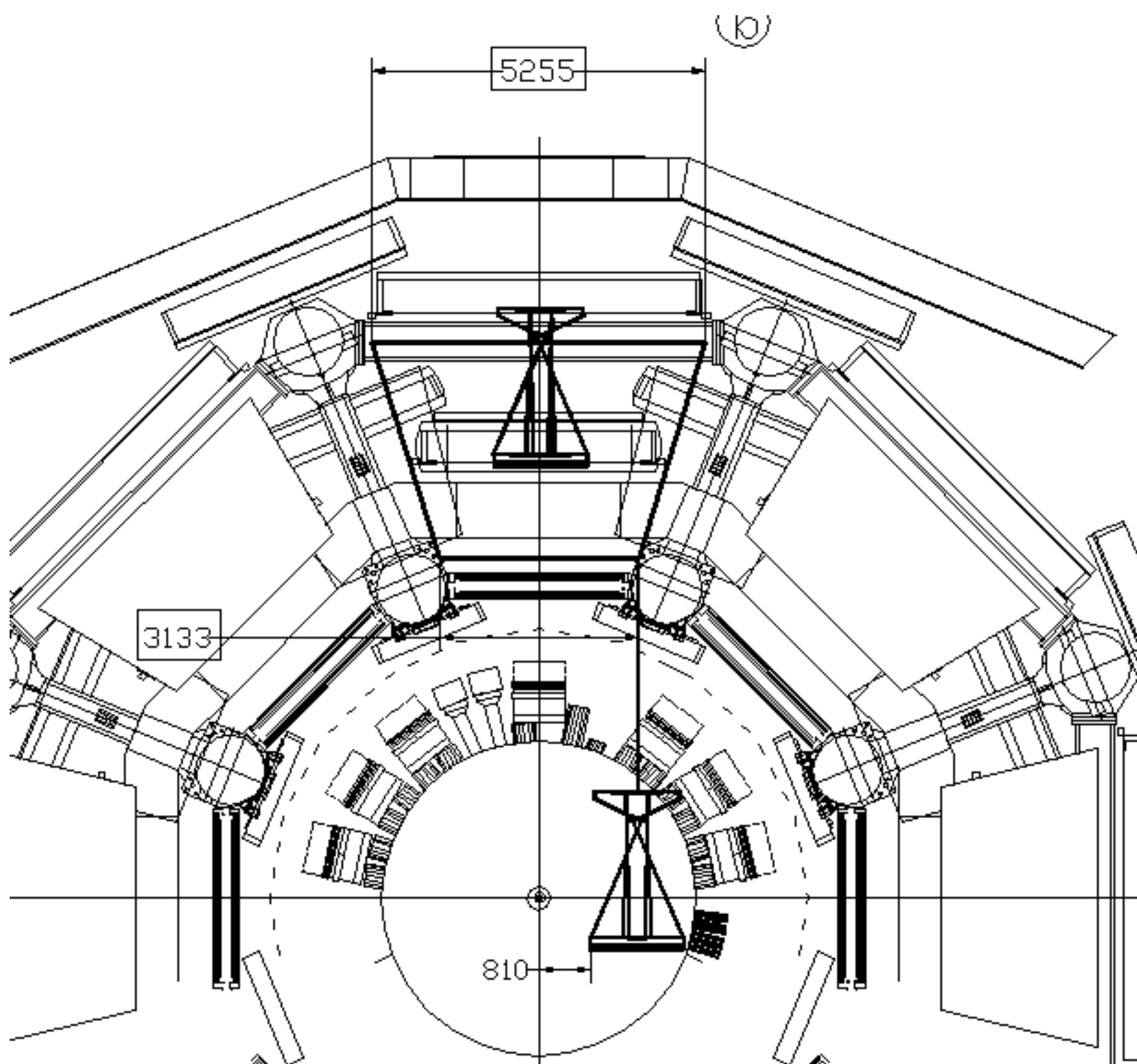

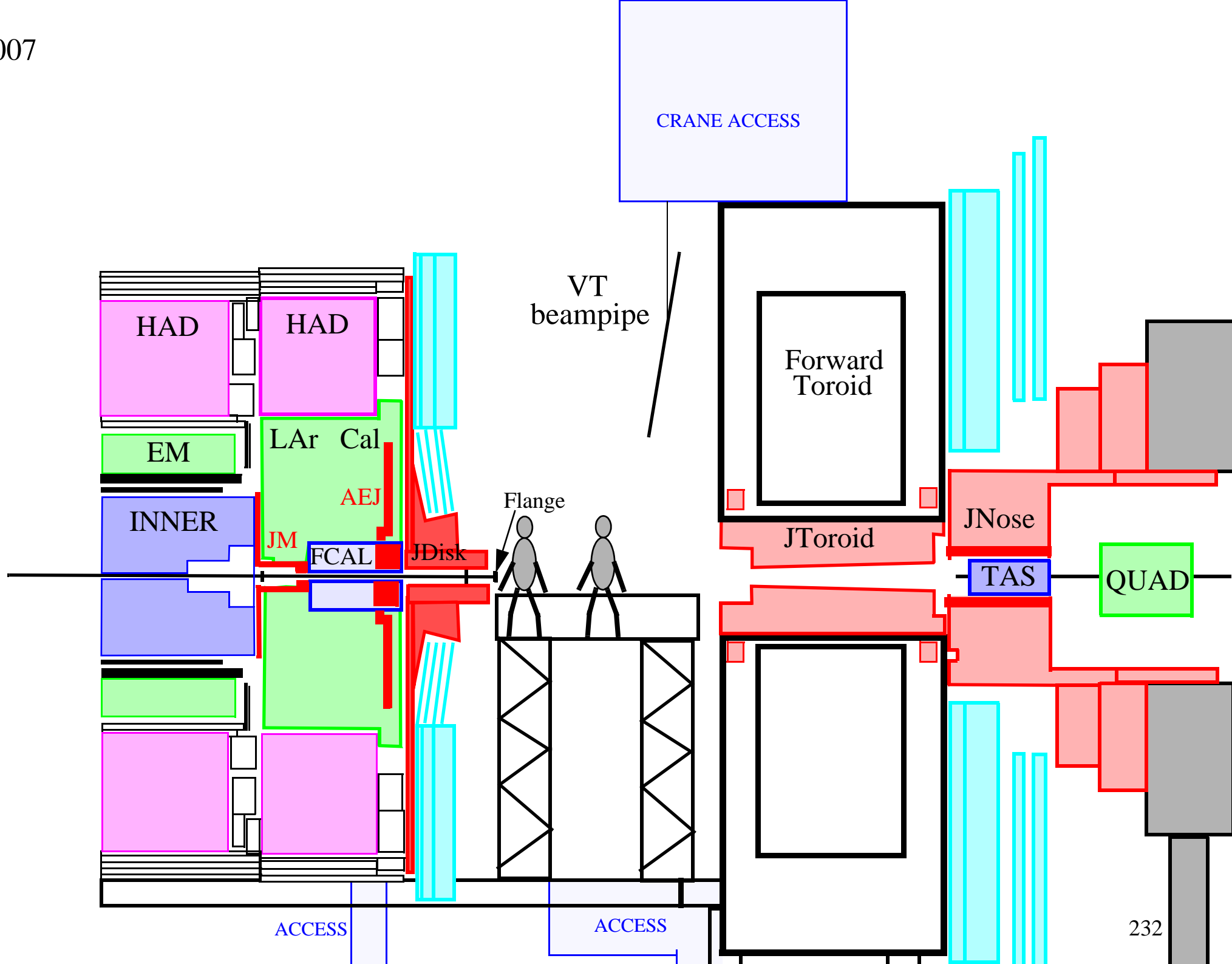

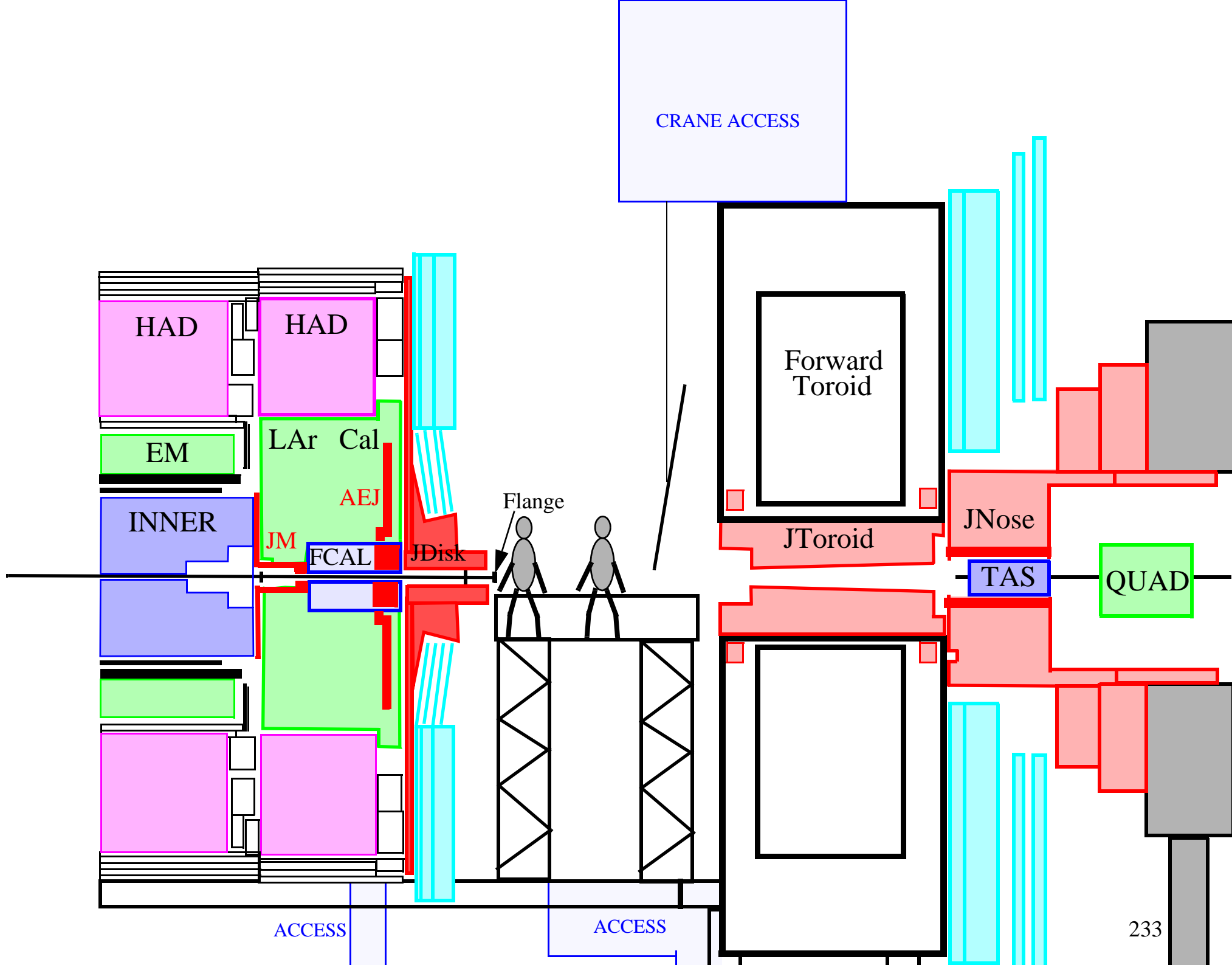

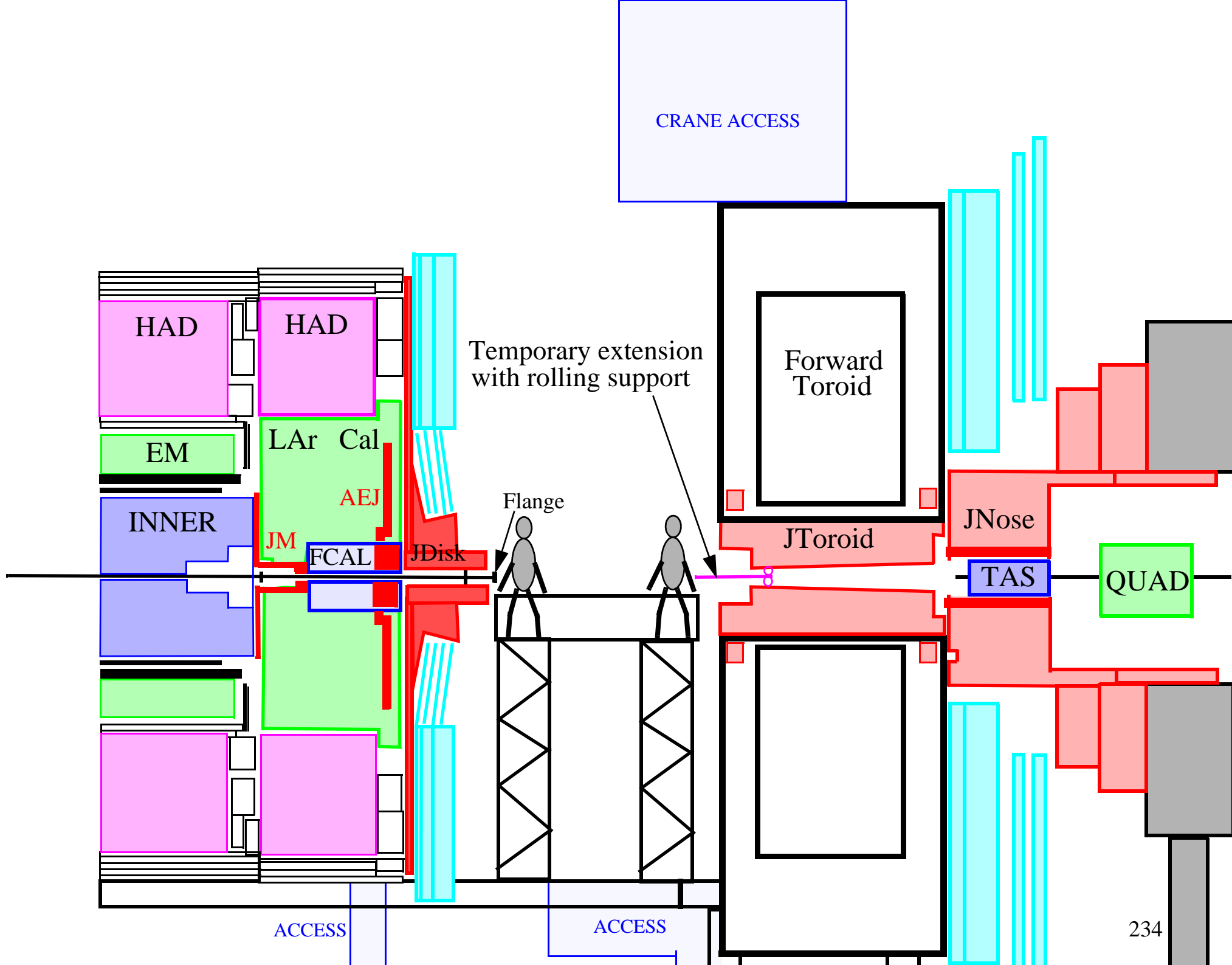

CRANE ACCESS

HAD

HAD

EM

INNER

JM

FCAL

JDisk

Temporary extension with rolling support

Flange

Forward Toroid

JToroid

JNose

TAS

QUAD

ACCESS

ACCESS

234

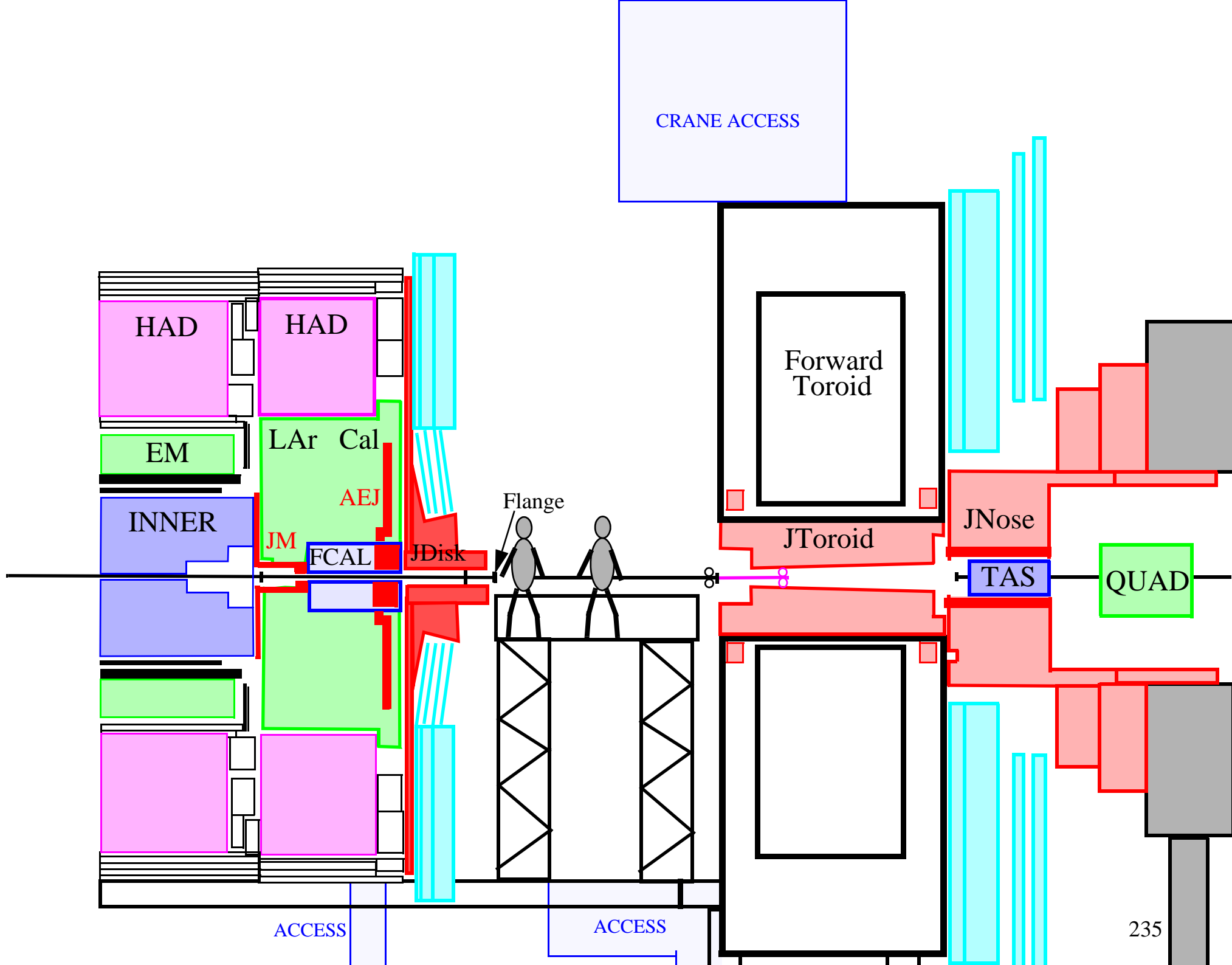

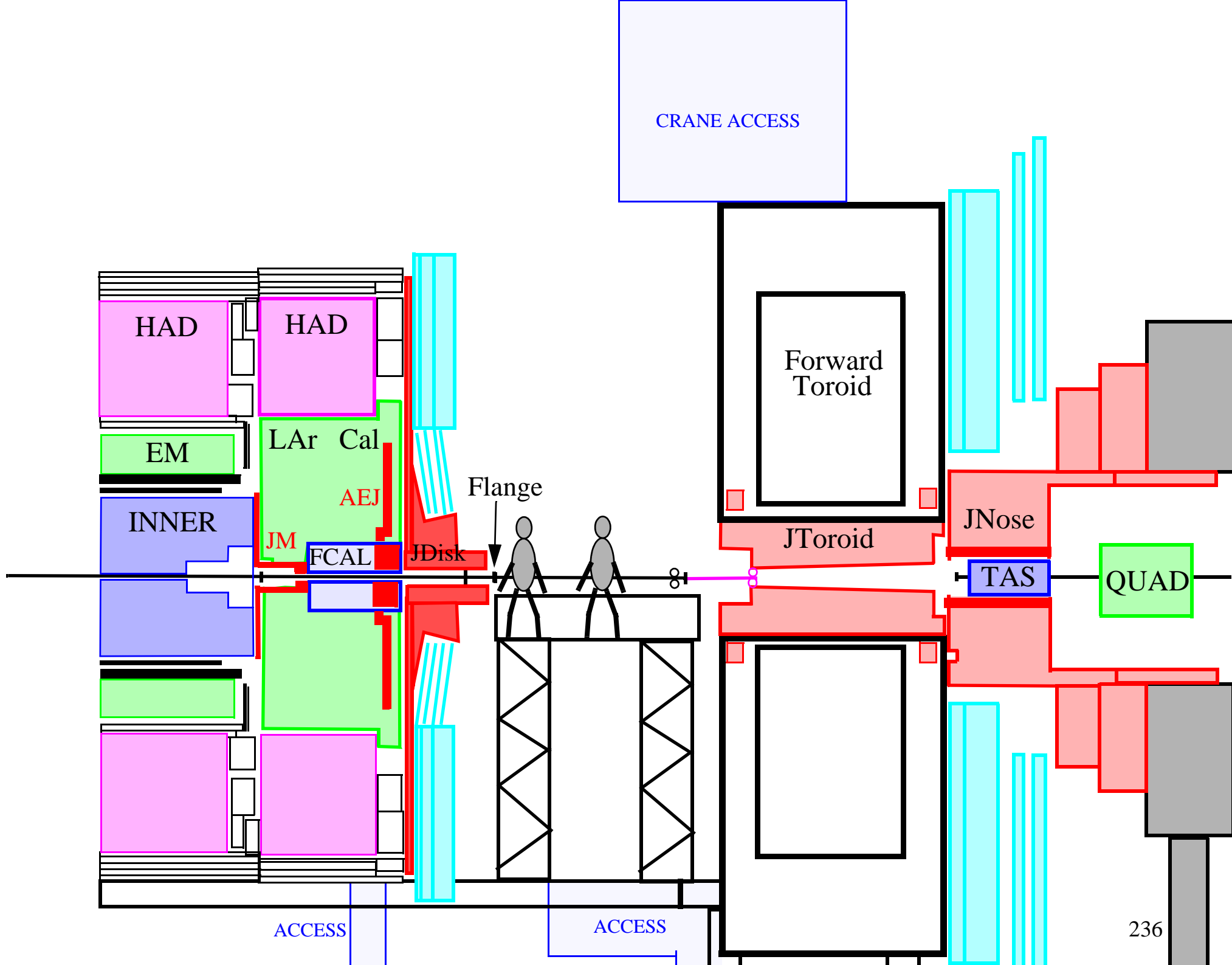

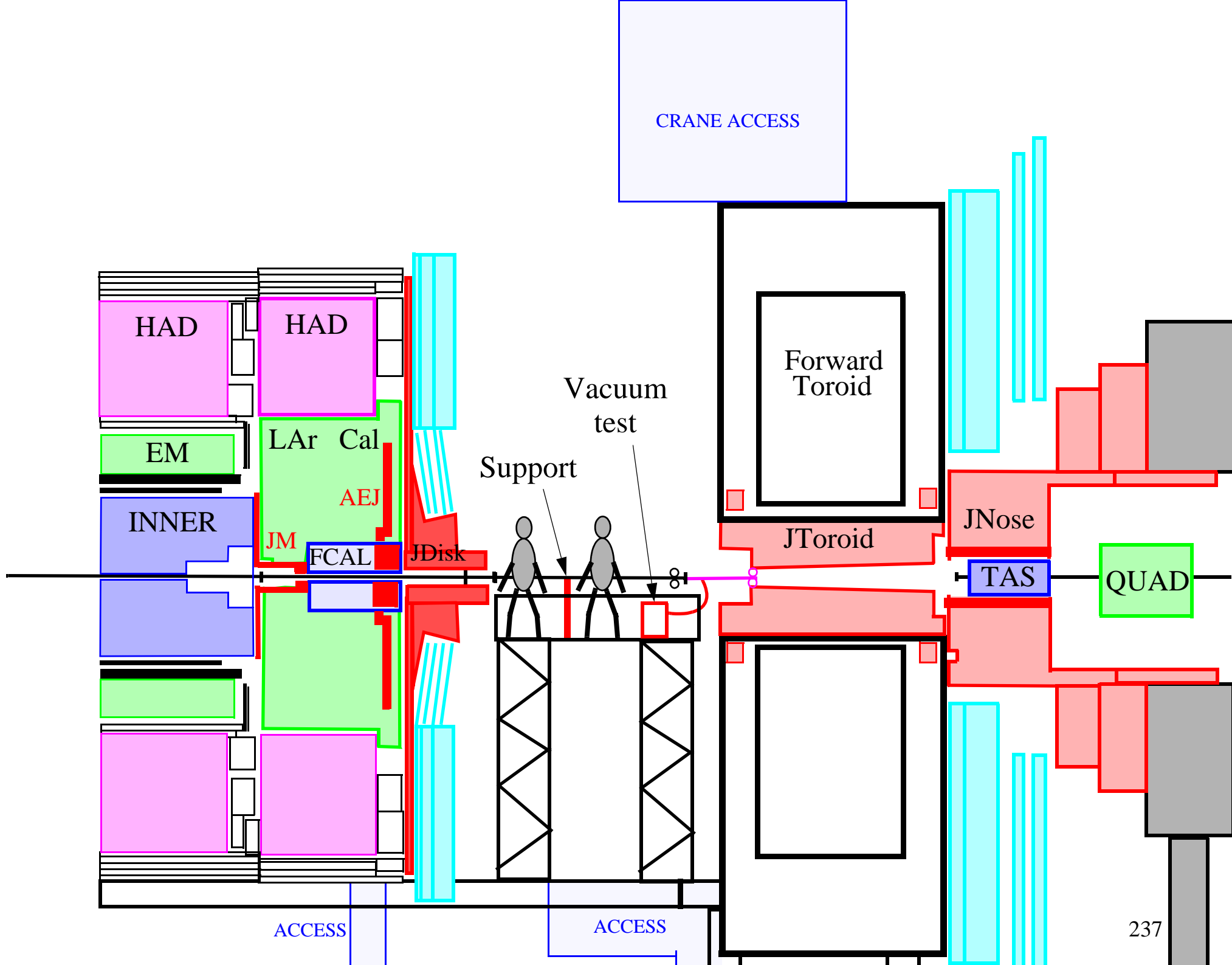

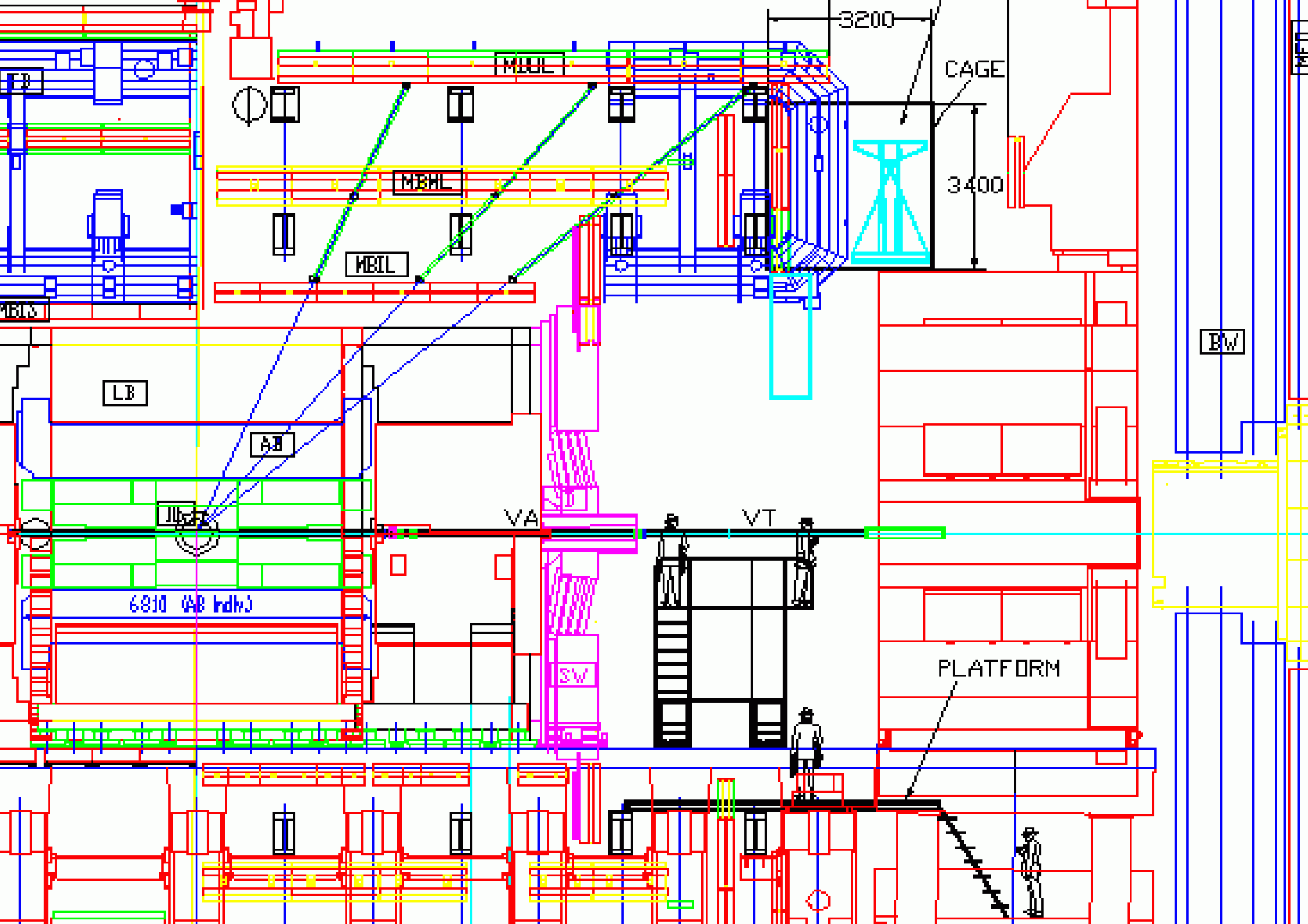

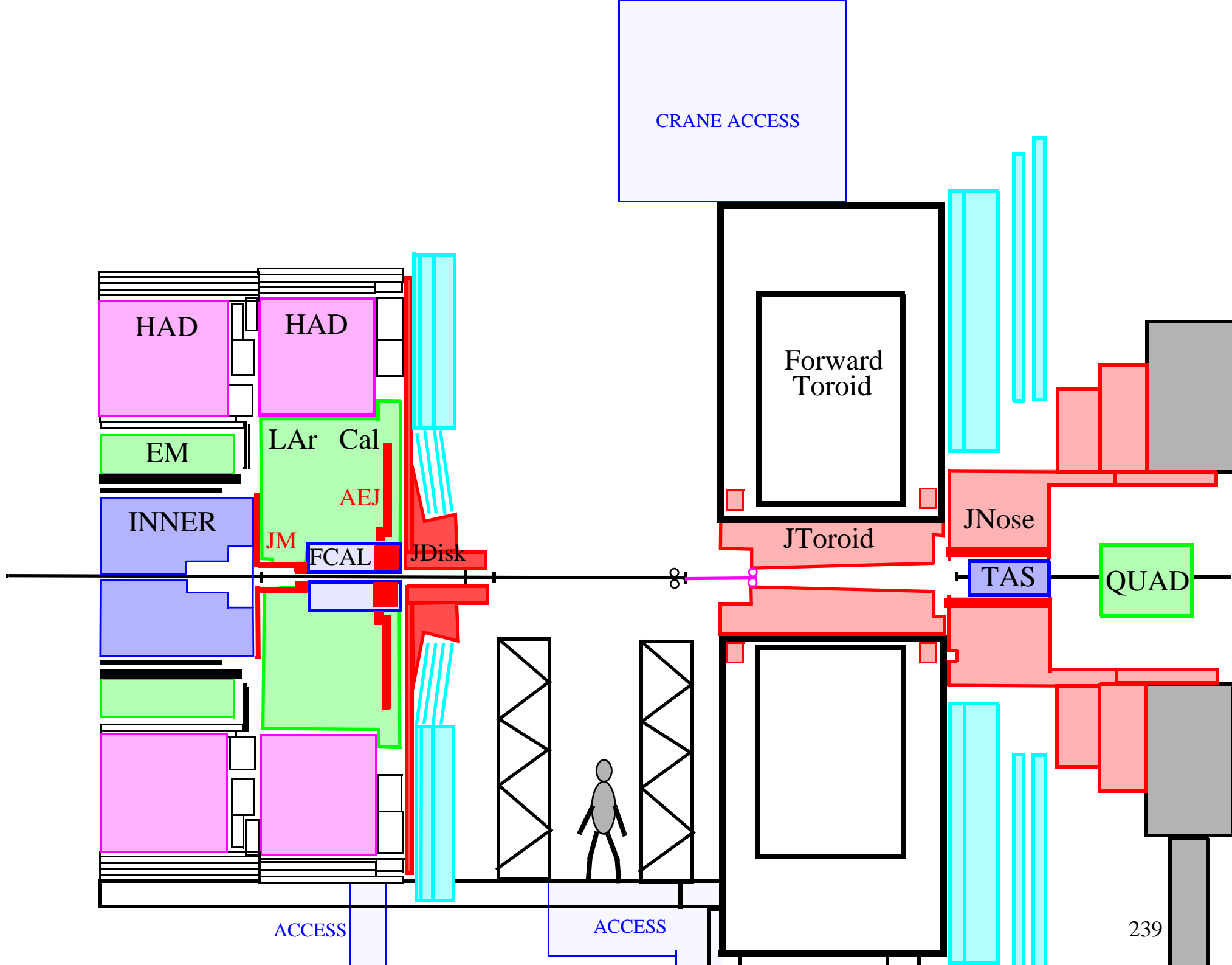

HAD

HAD

EM

LAr Cal

INNER

AEJ

JM

FCAL

JDisk

Forward Toroid

JToroid

JNose

TAS

QUAD

CRANE ACCESS

ACCESS

ACCESS

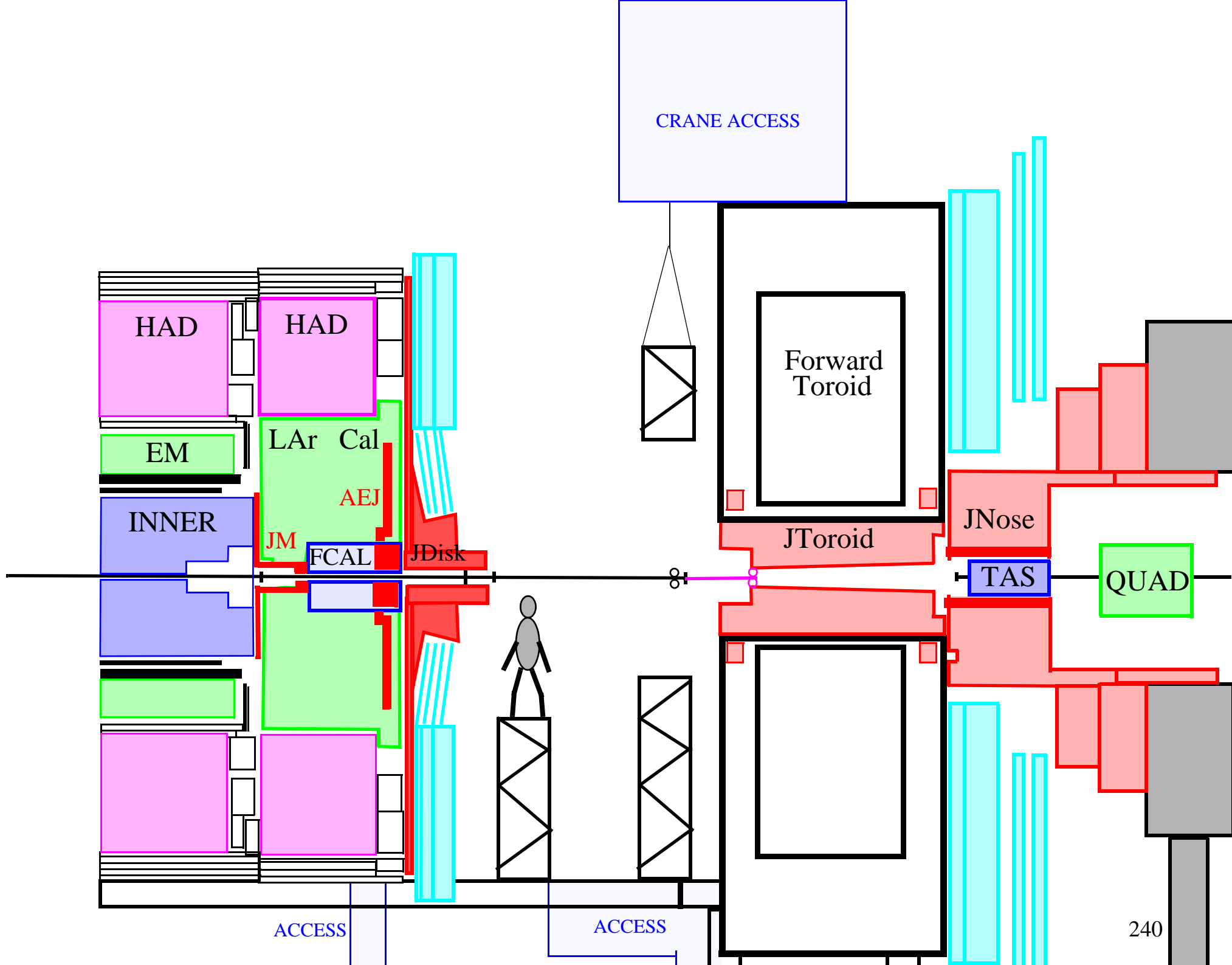

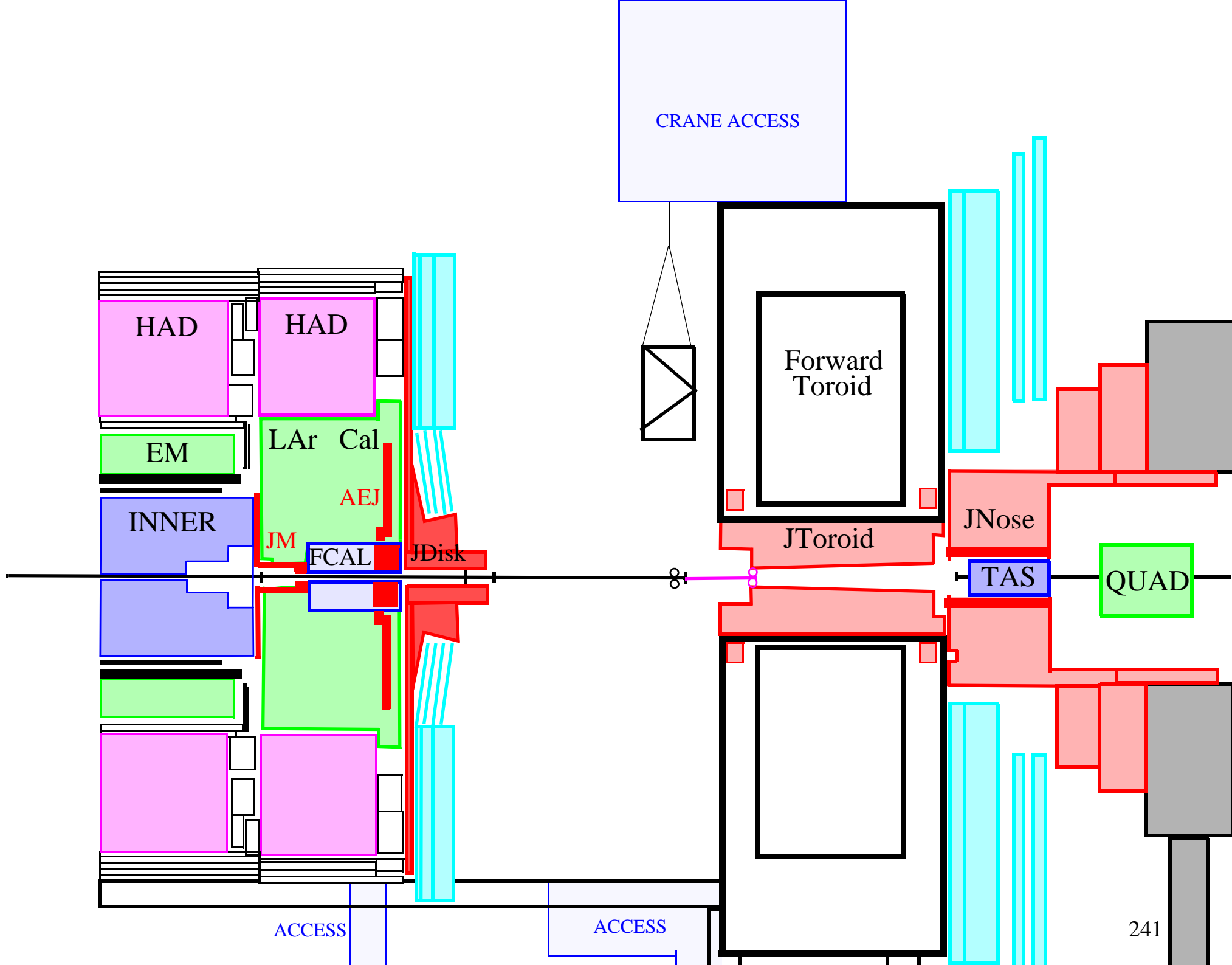

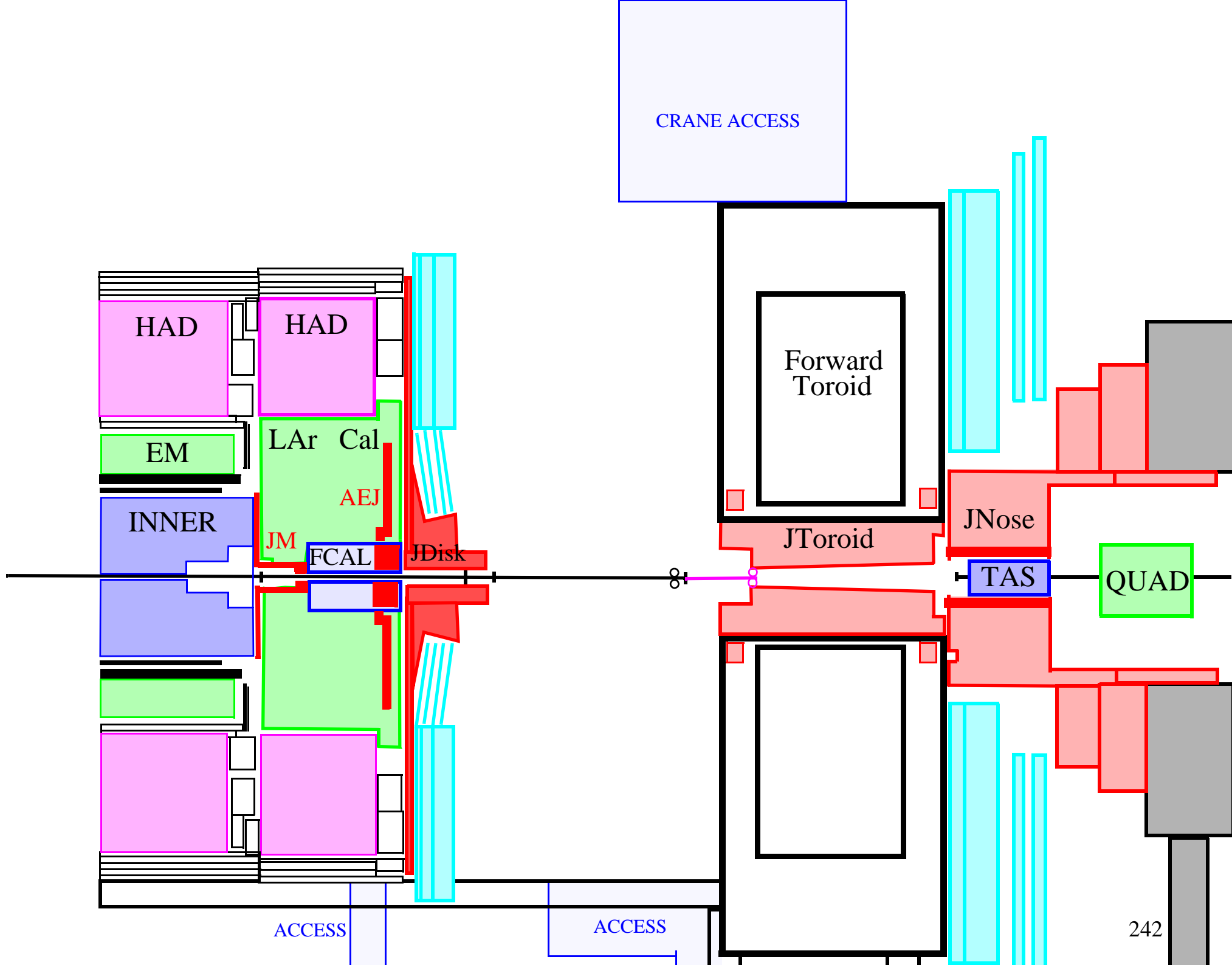

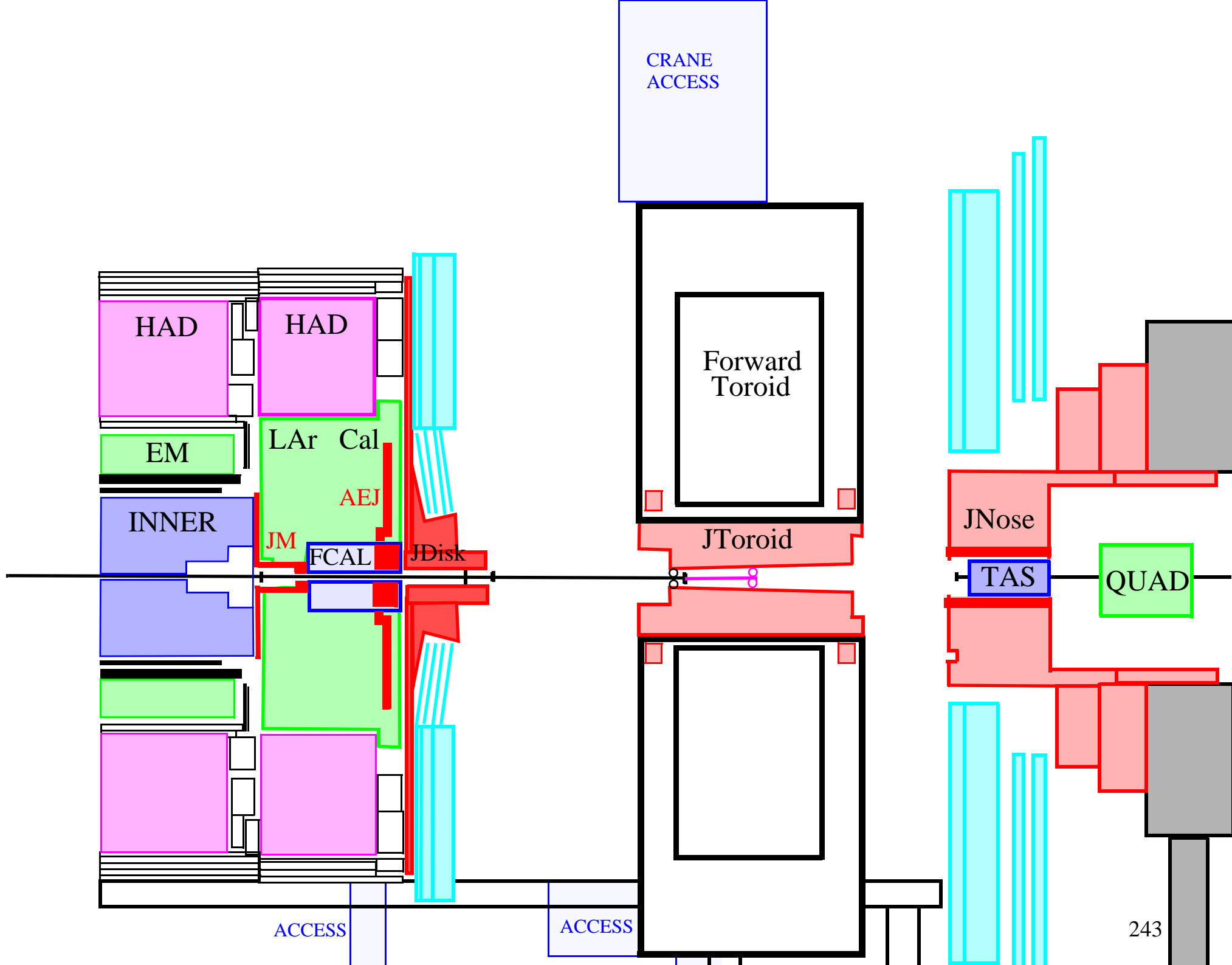

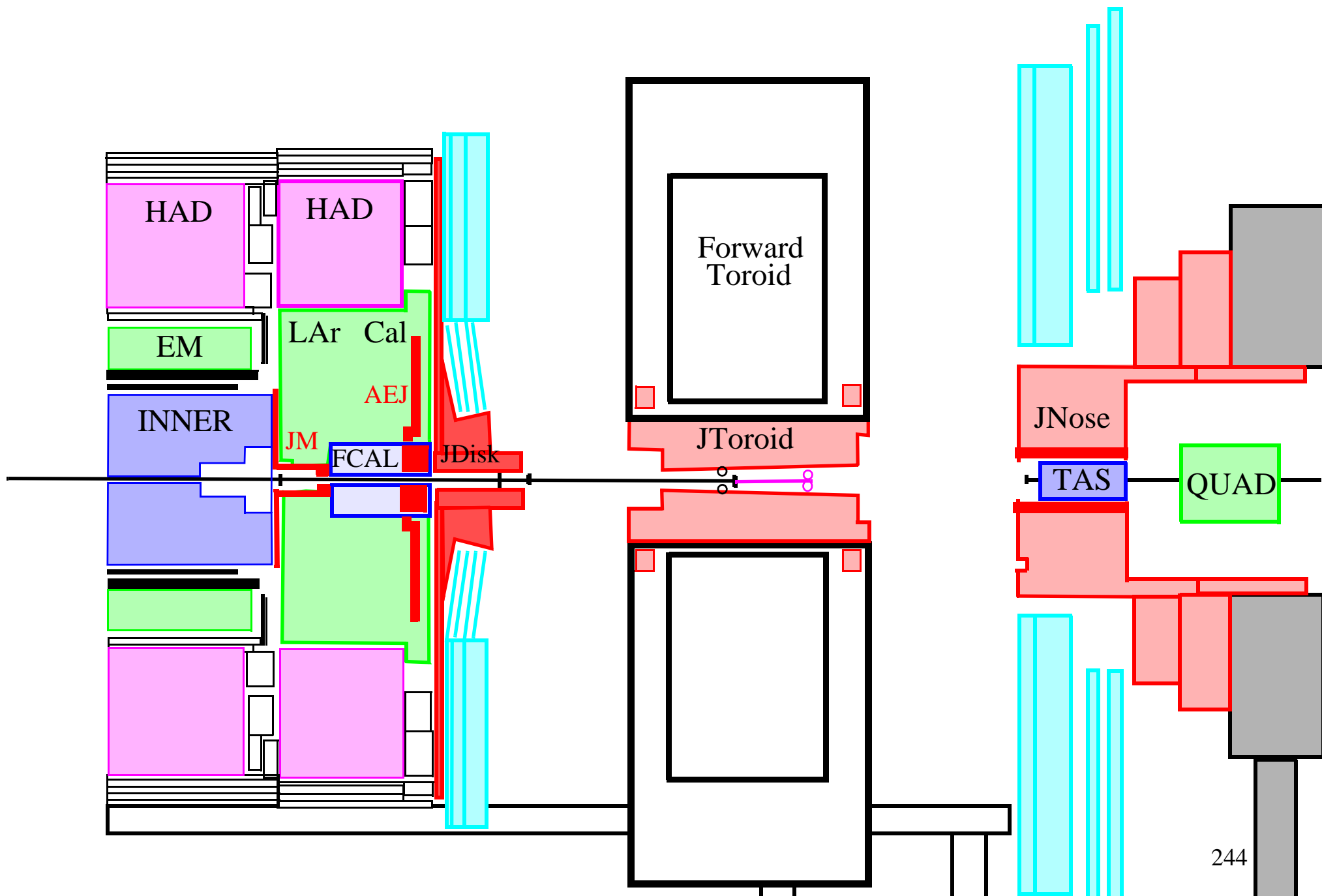

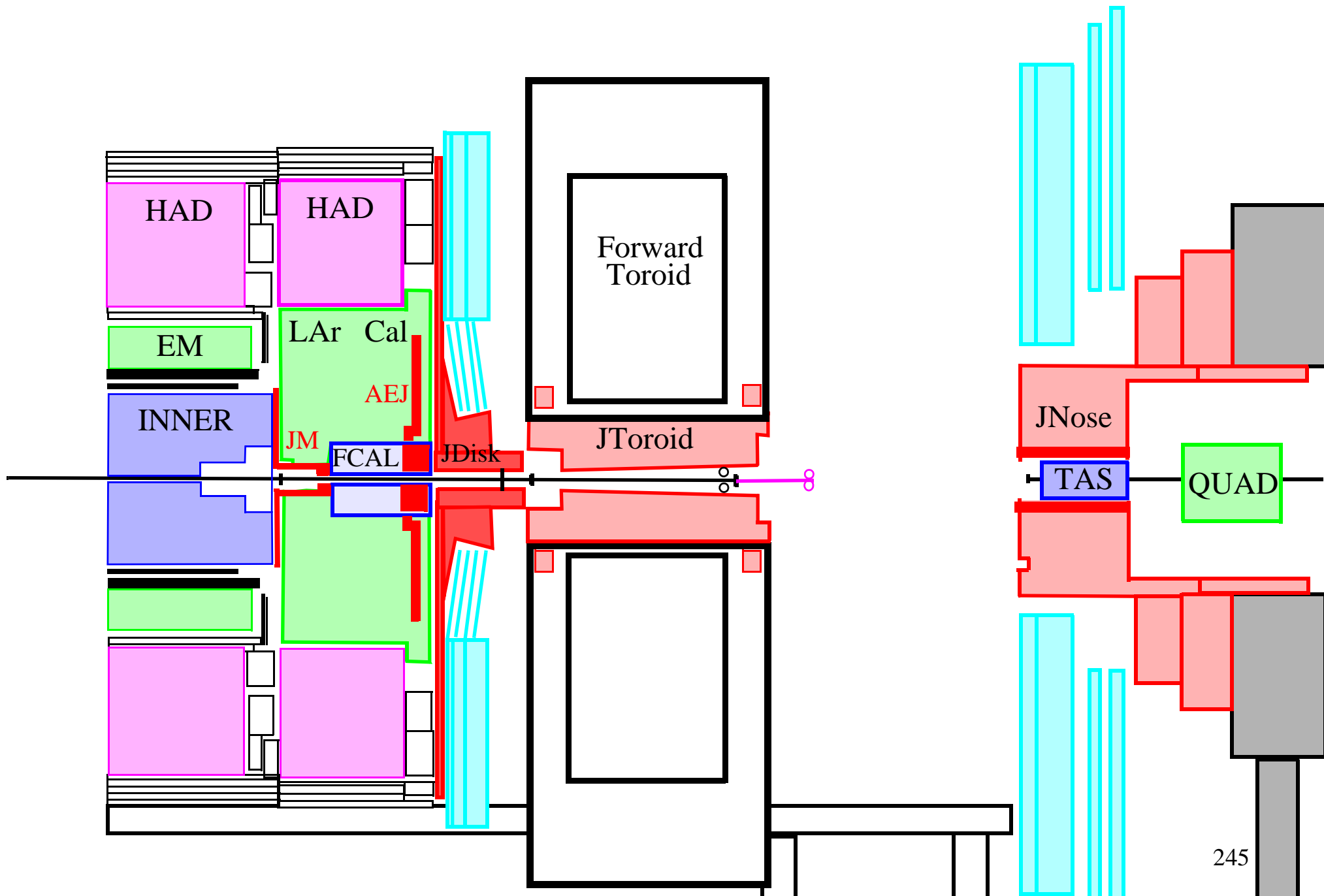

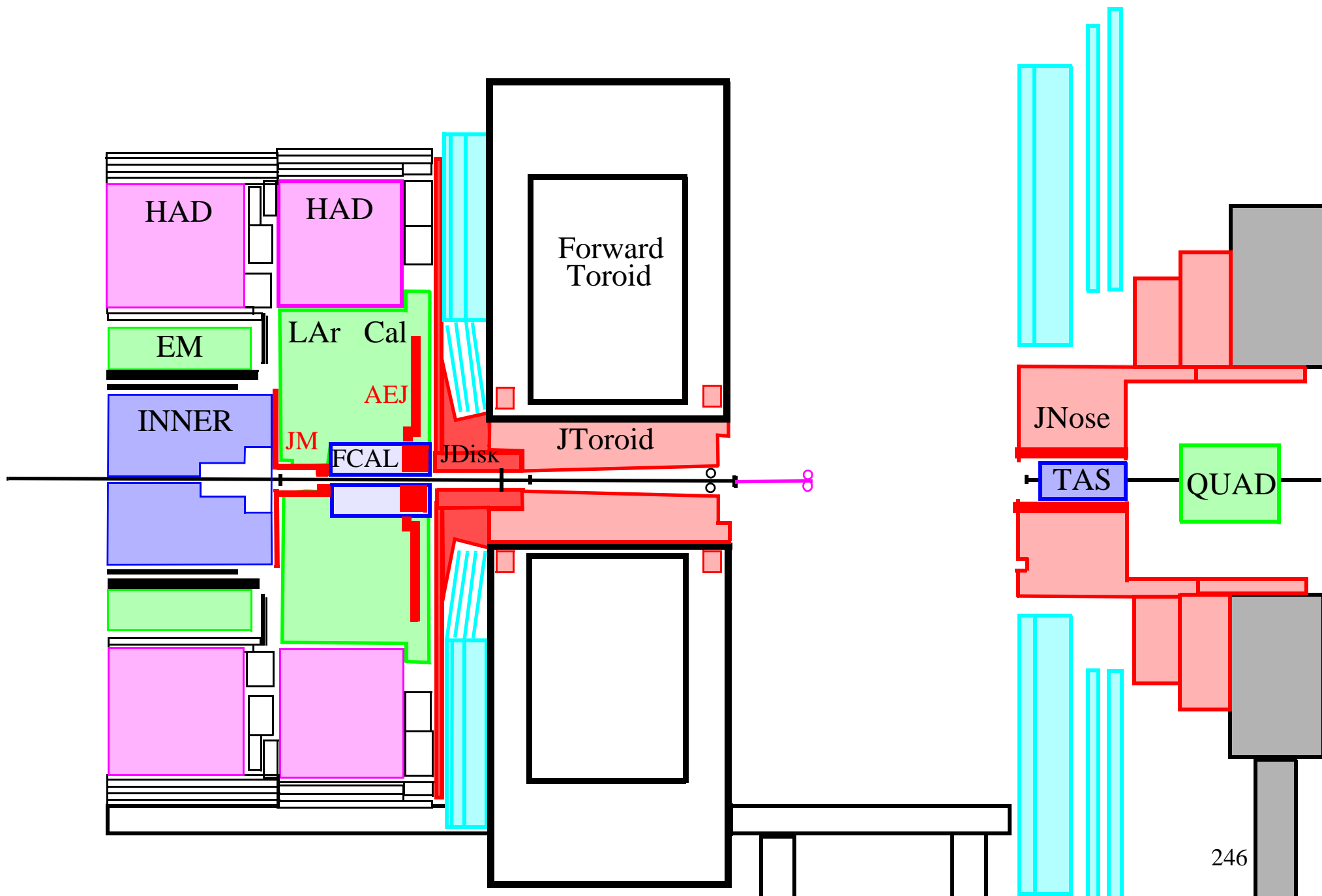

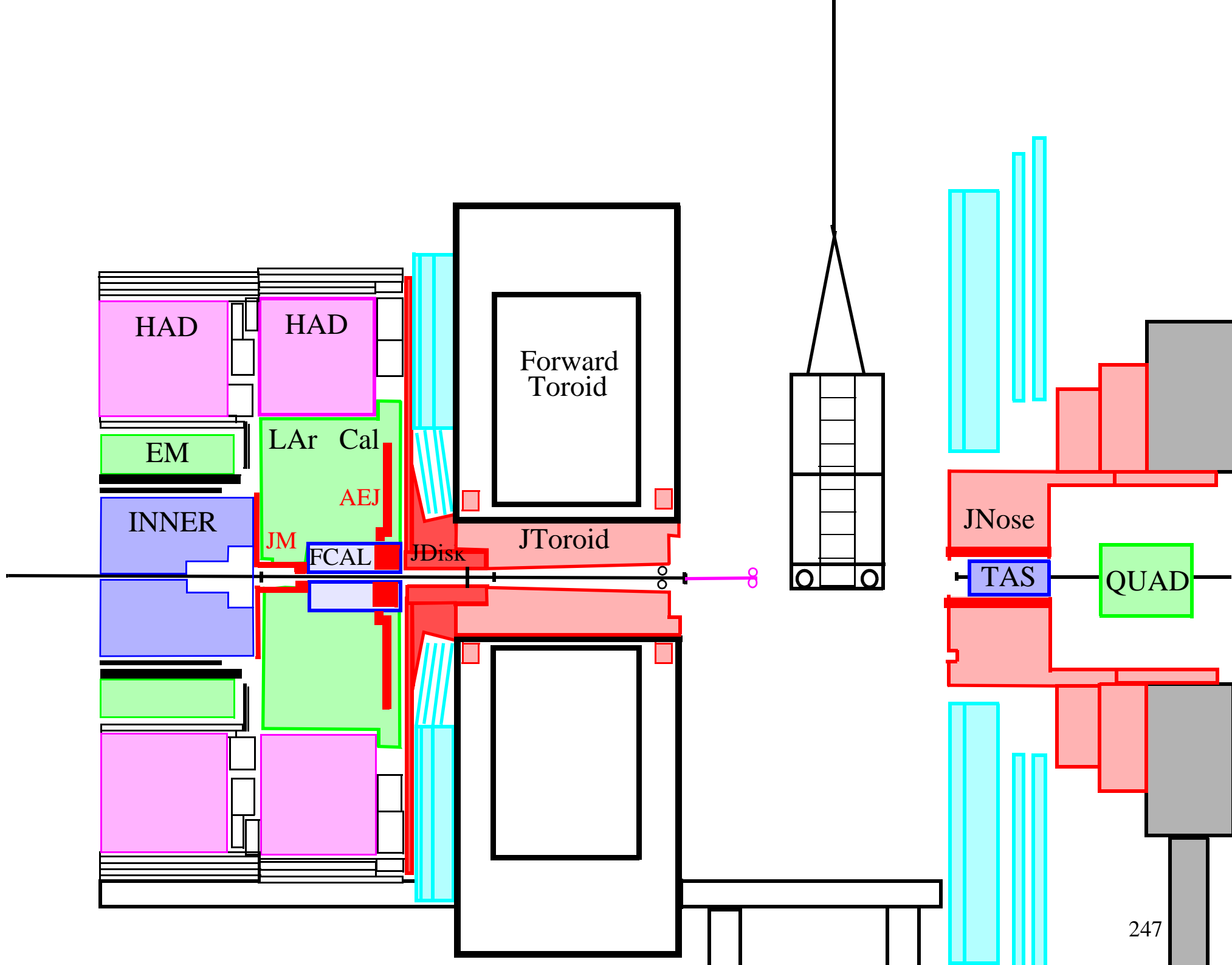

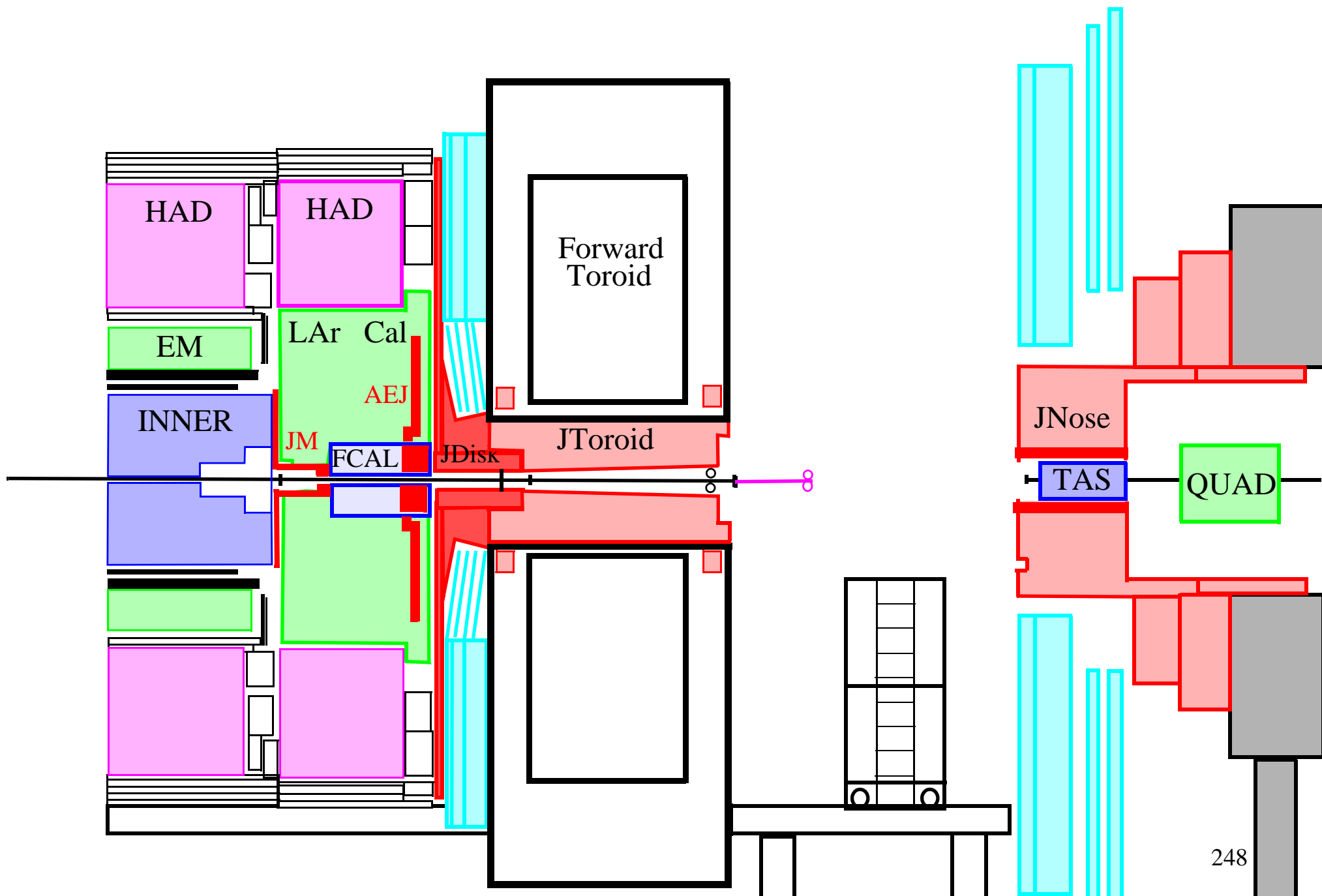

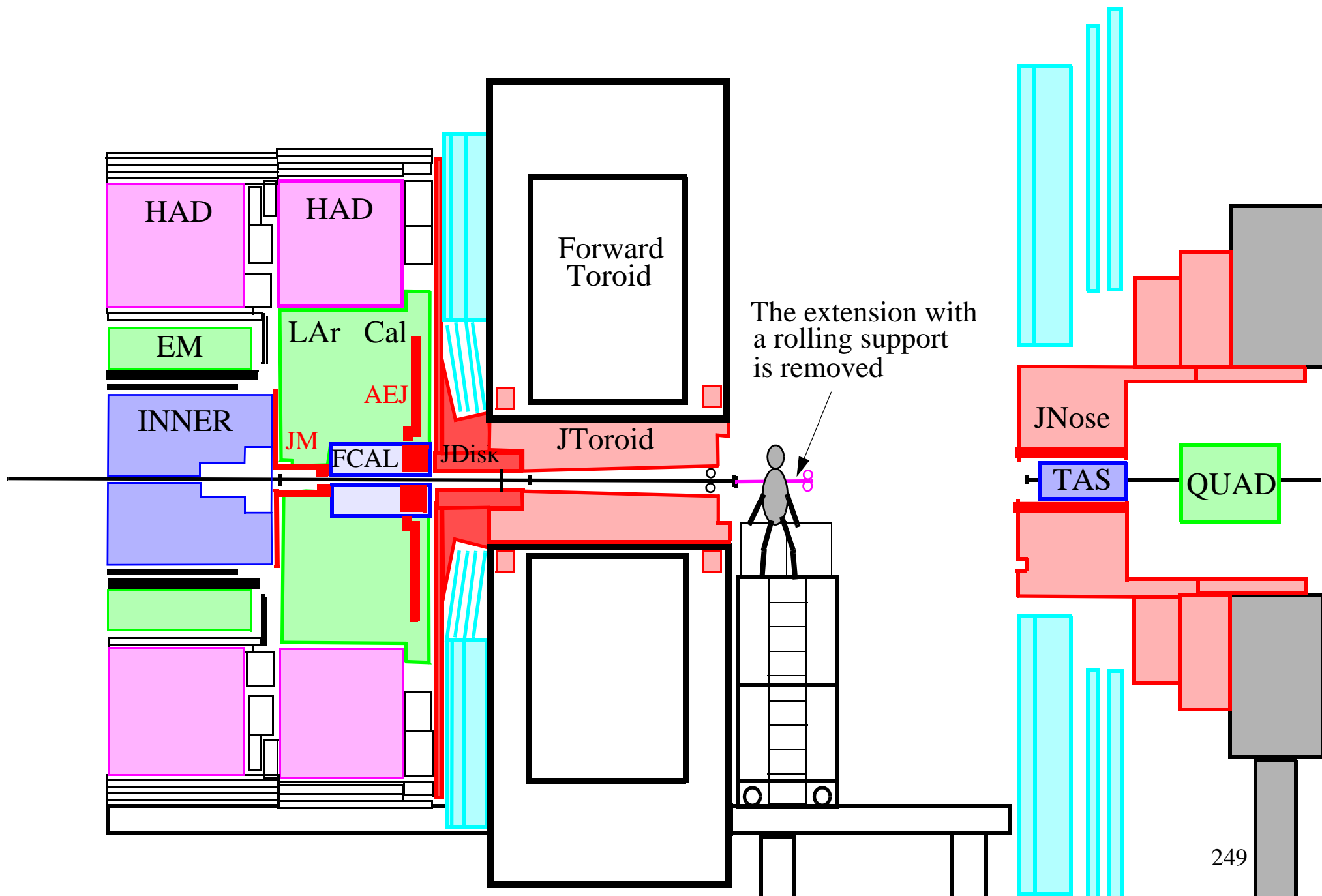

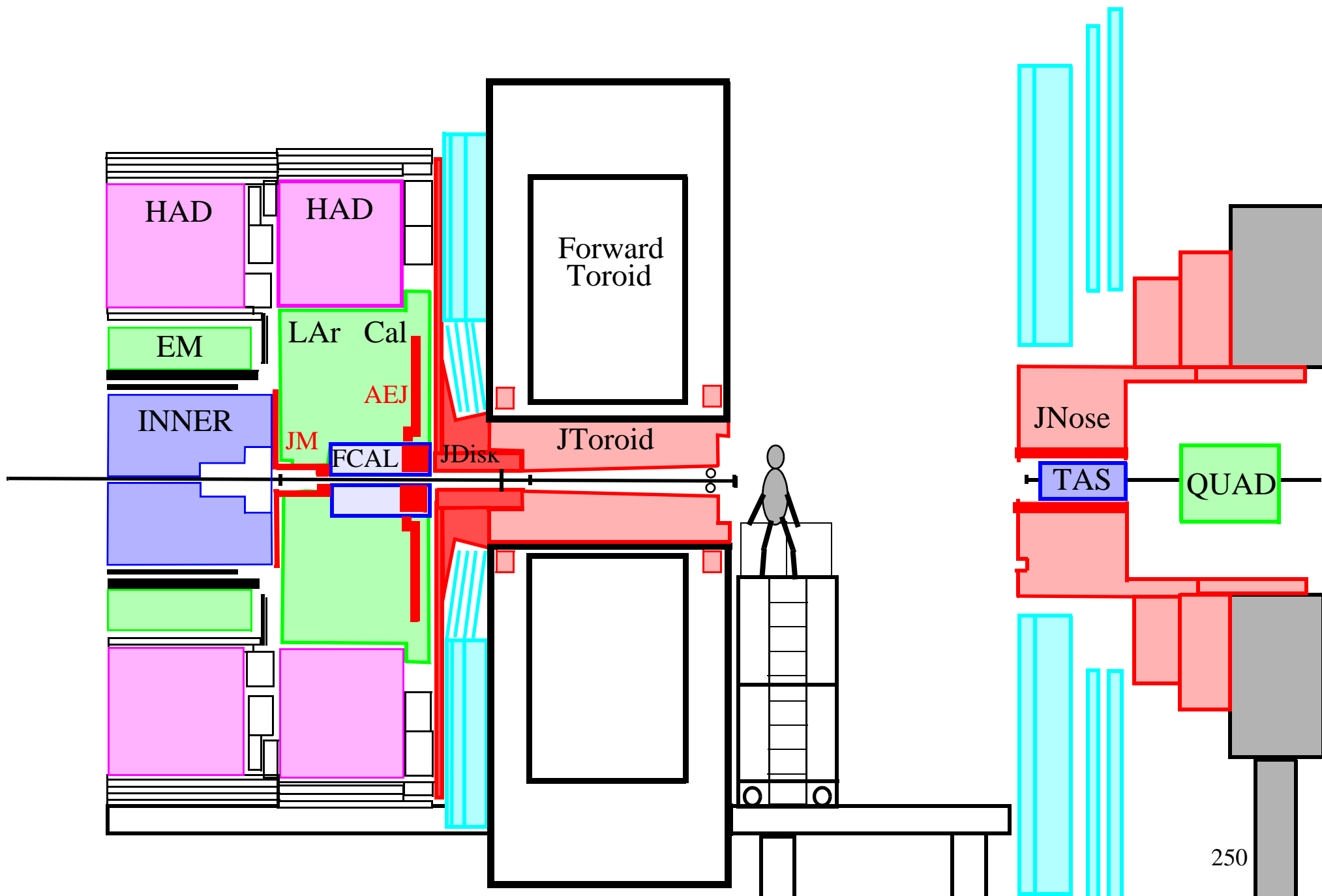

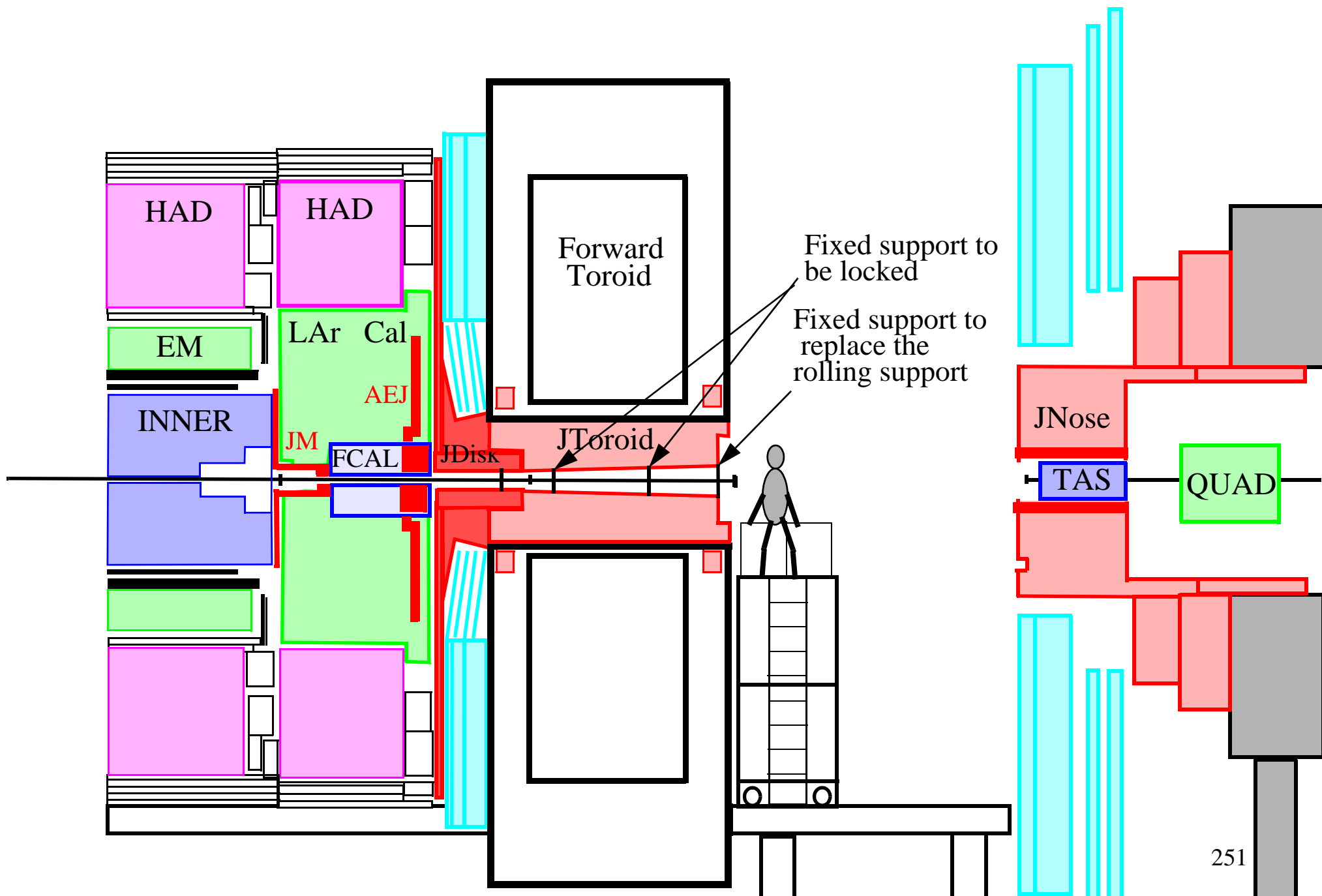

Beampipe supports

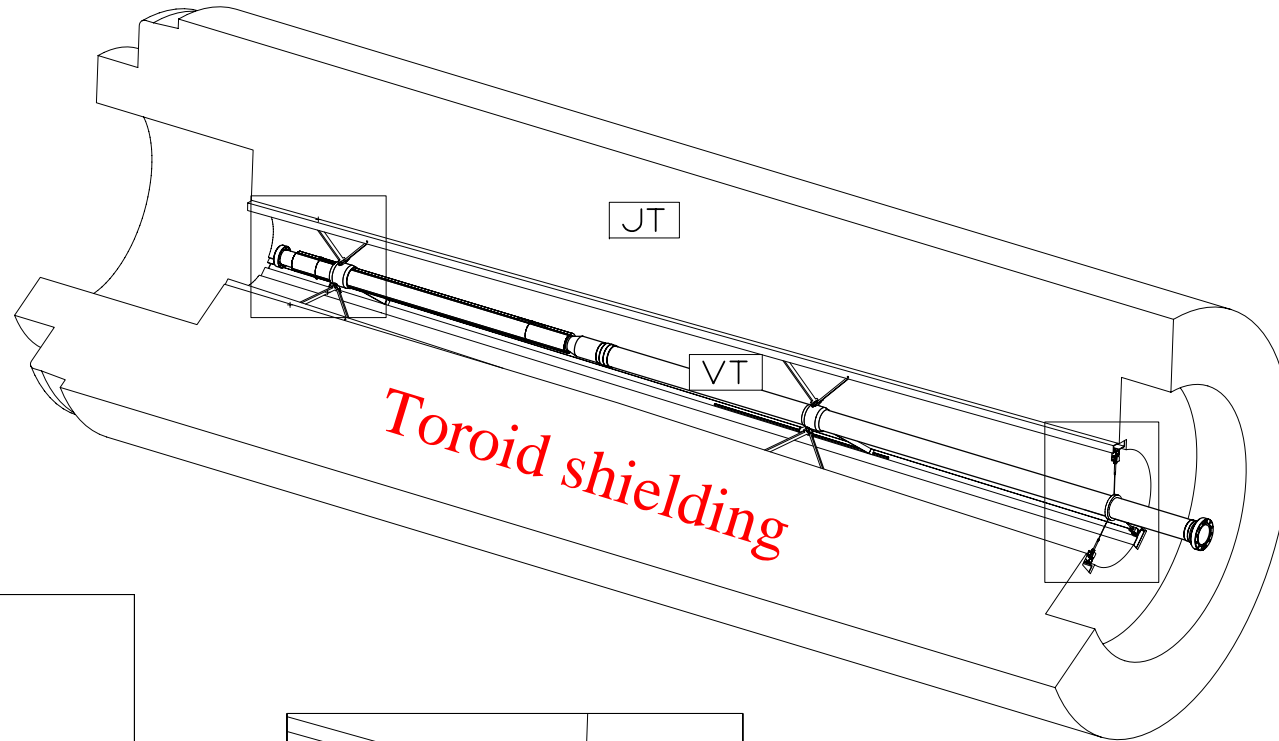

This support has to be locked.

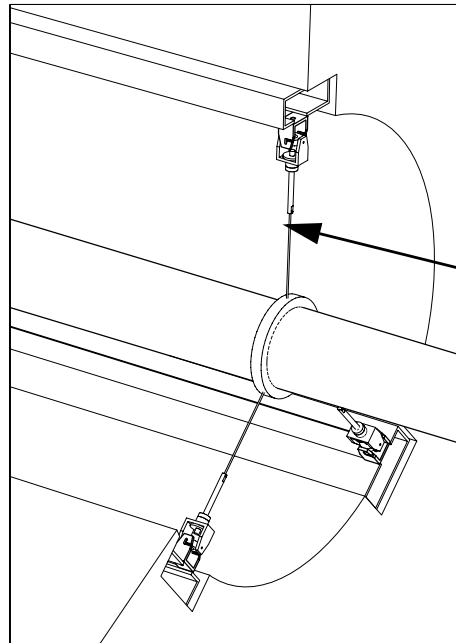
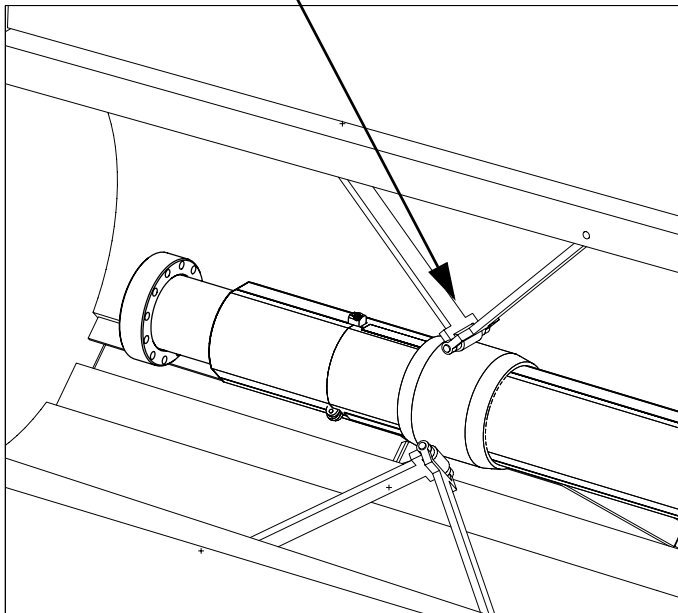
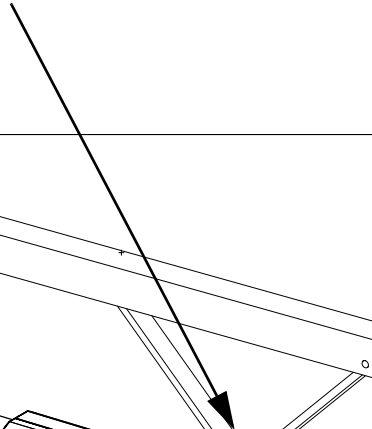

This support has to be attached and the rolling support has to be removed.

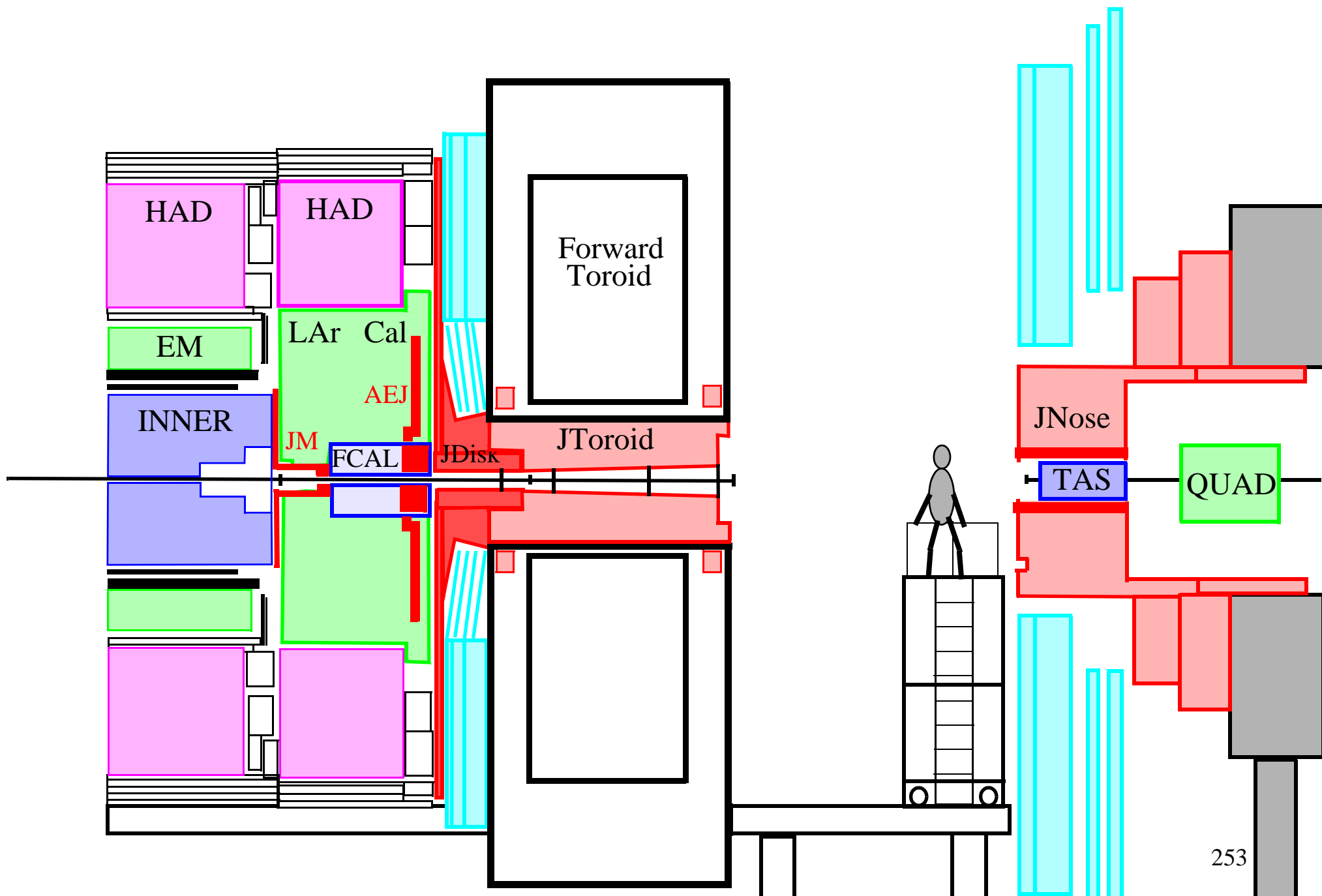

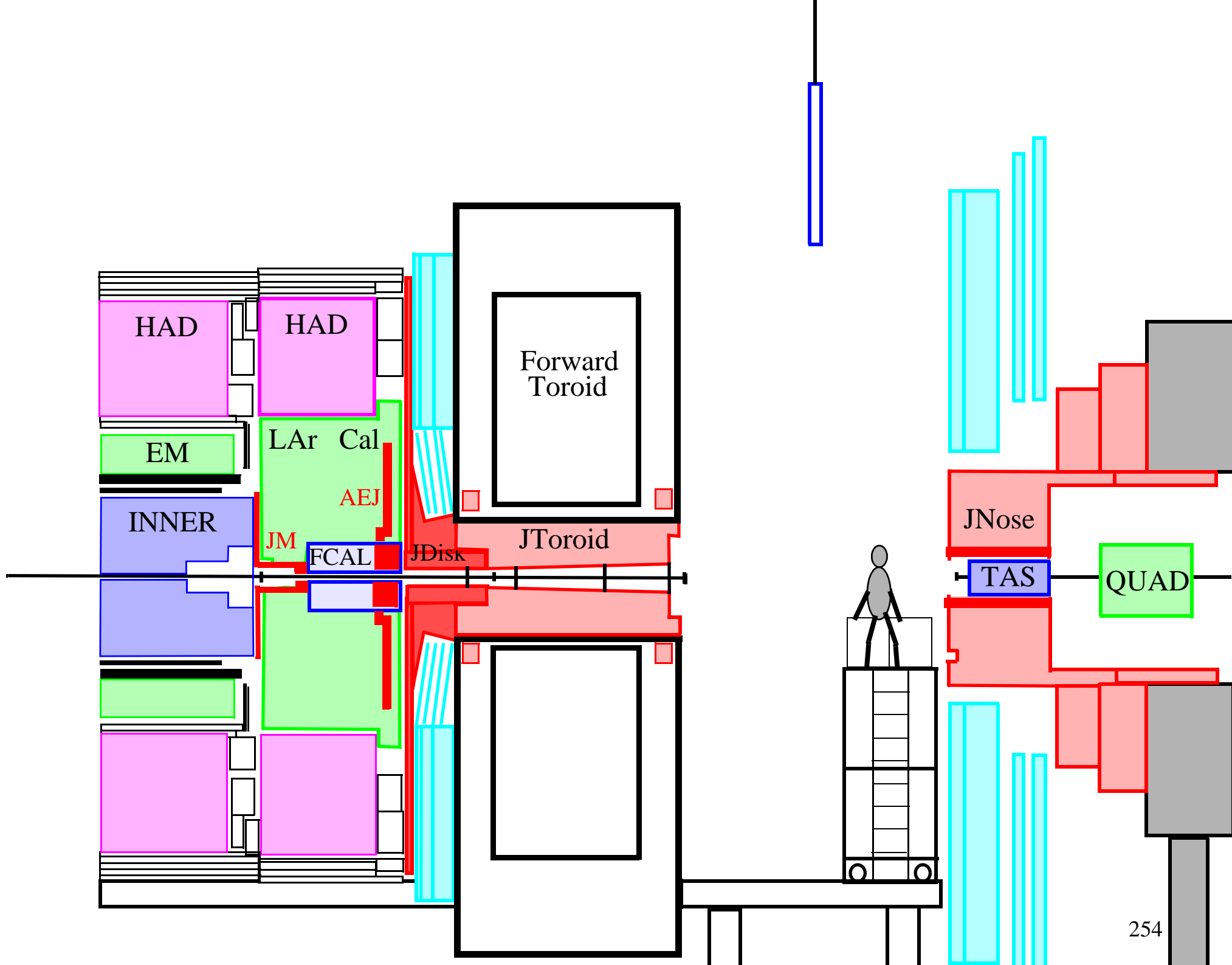

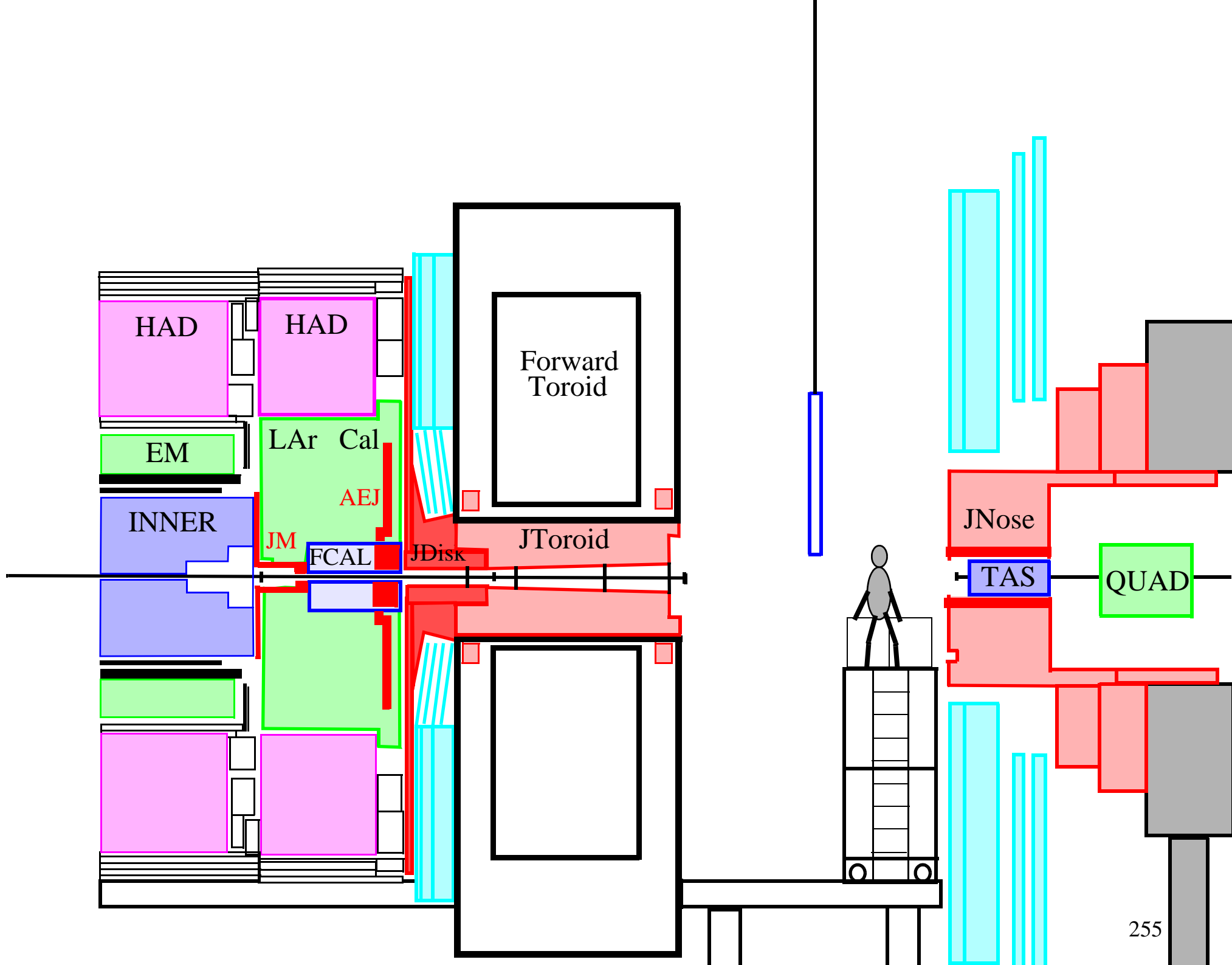

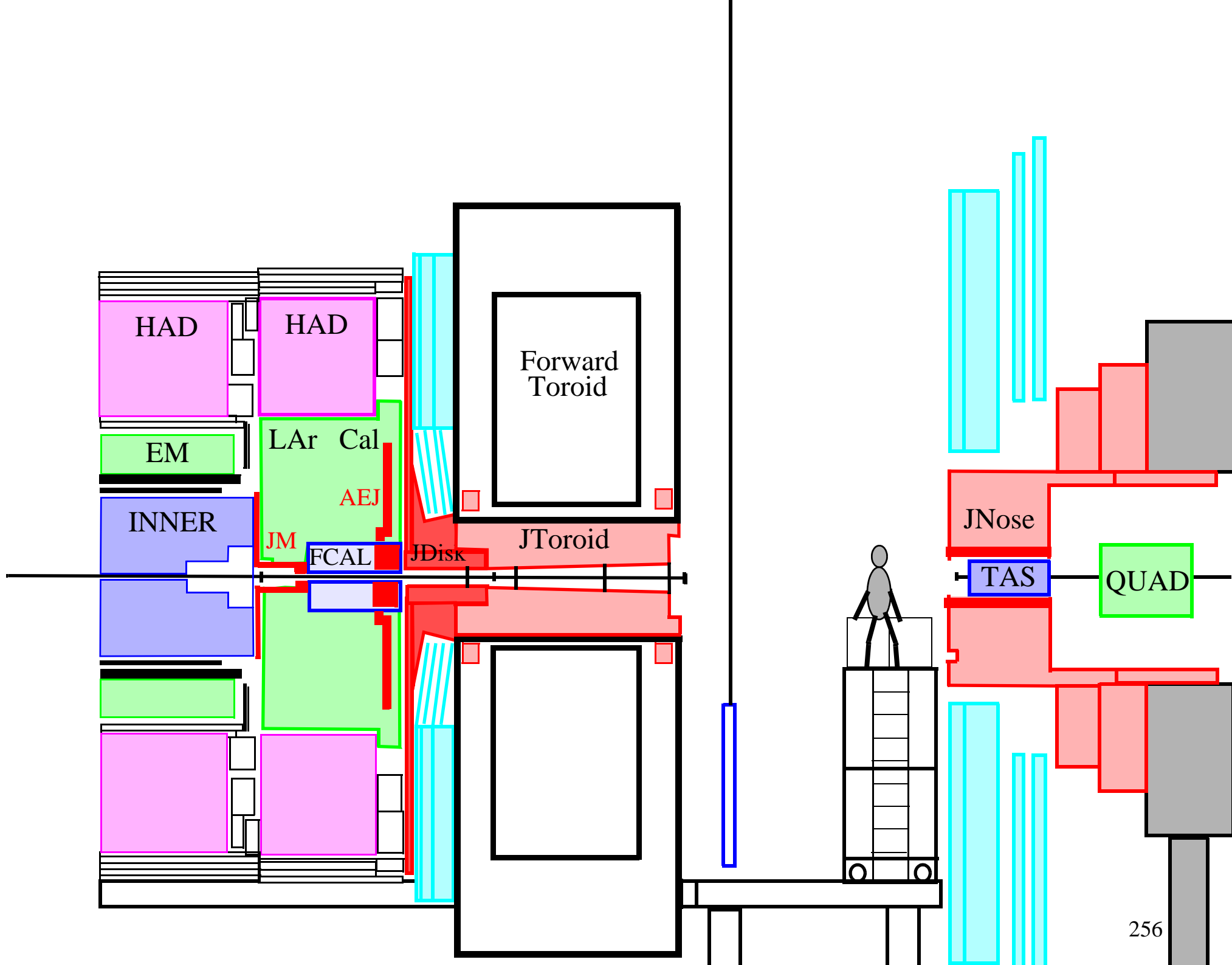

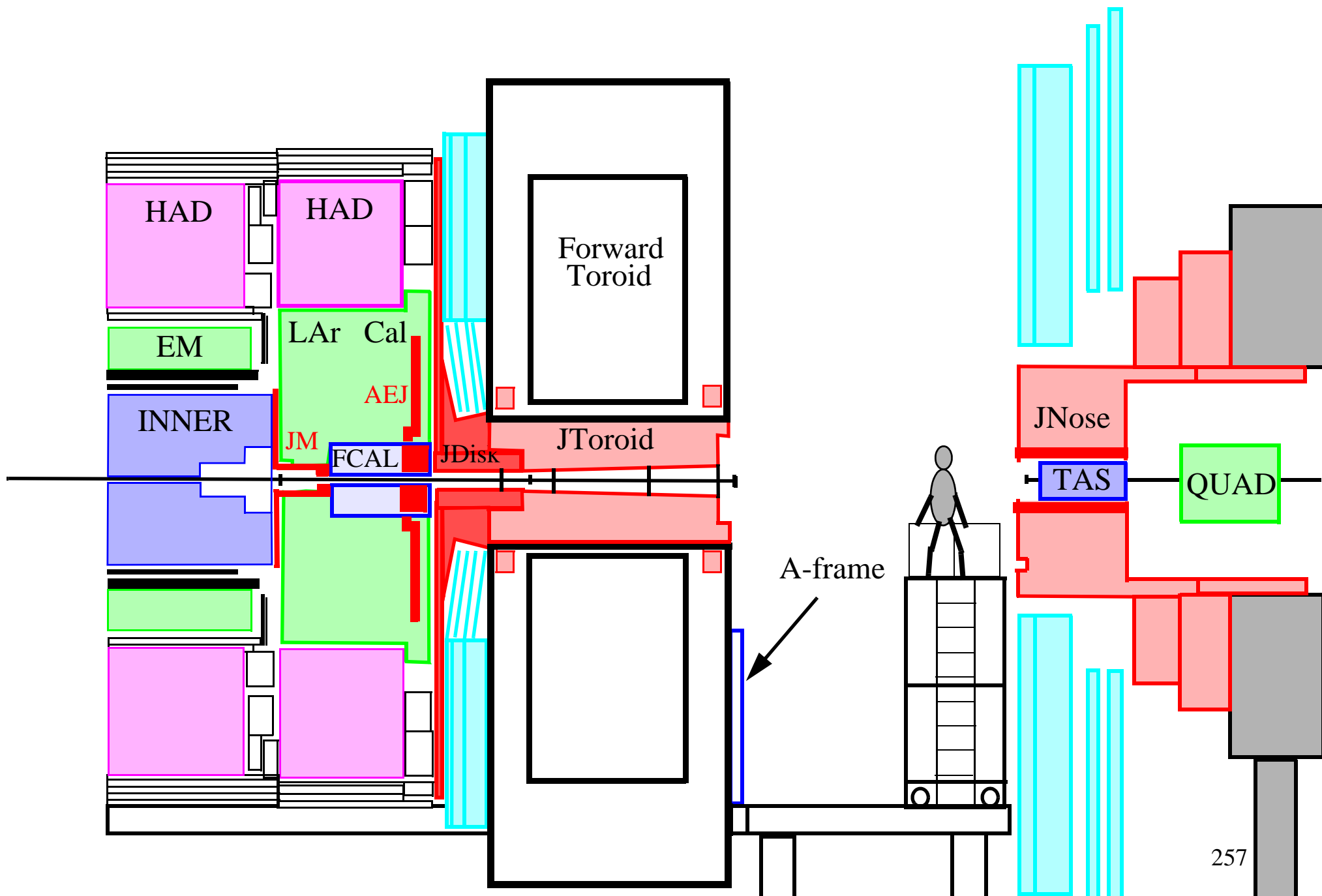

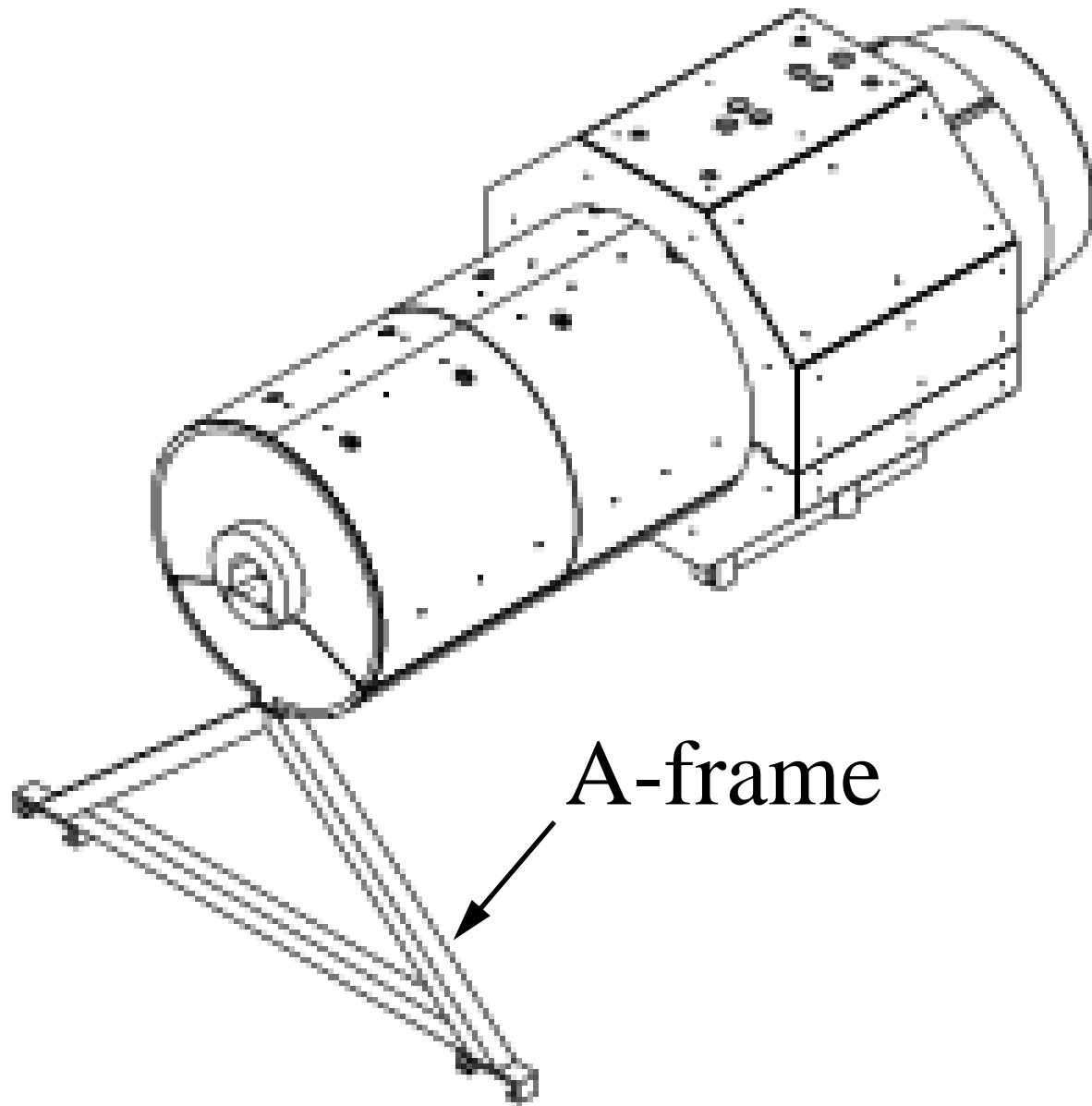

A-frame

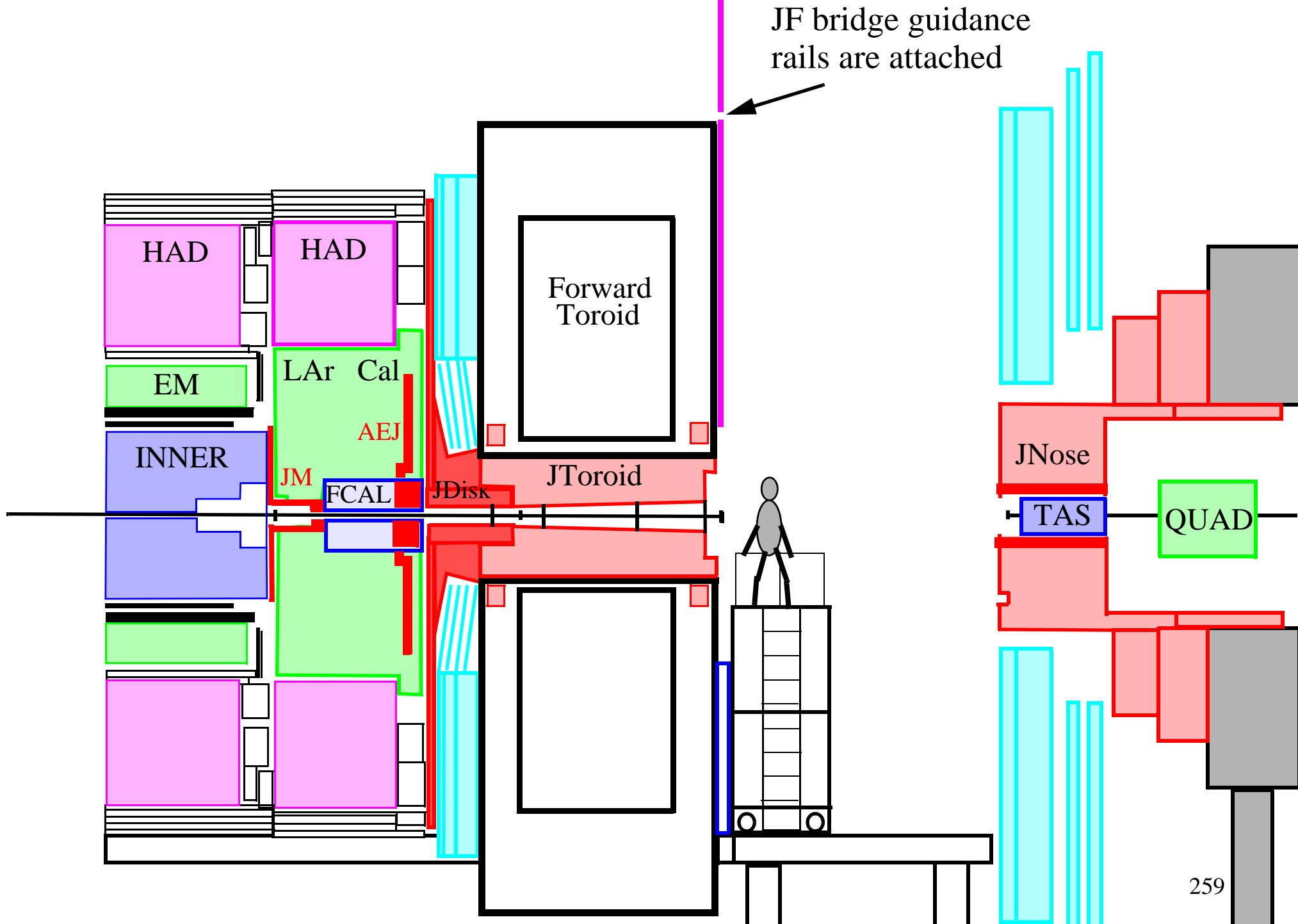

JF bridge guidance rails are attached

JF bridge guidance rails are attached to the rails above the toroid.

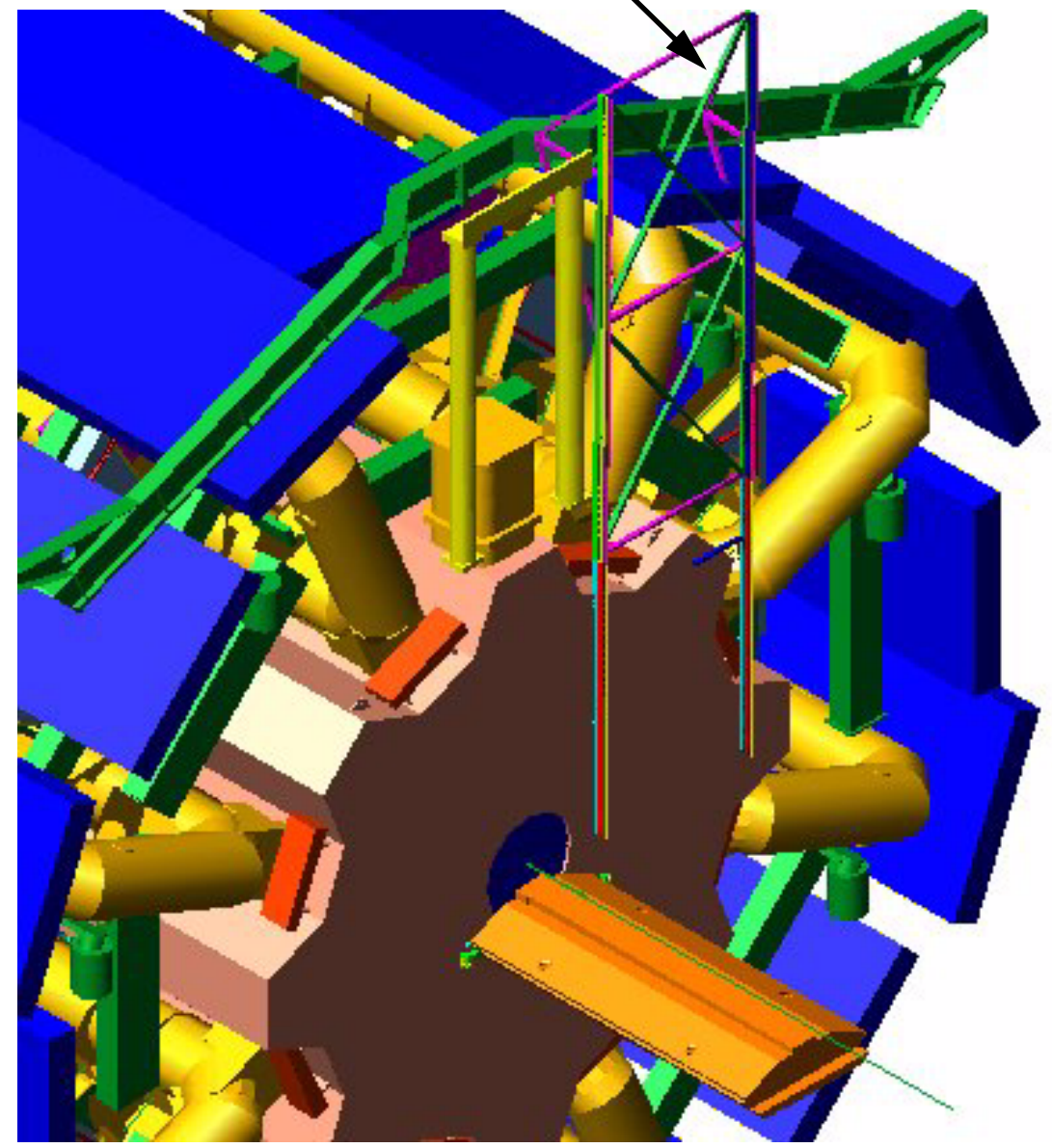
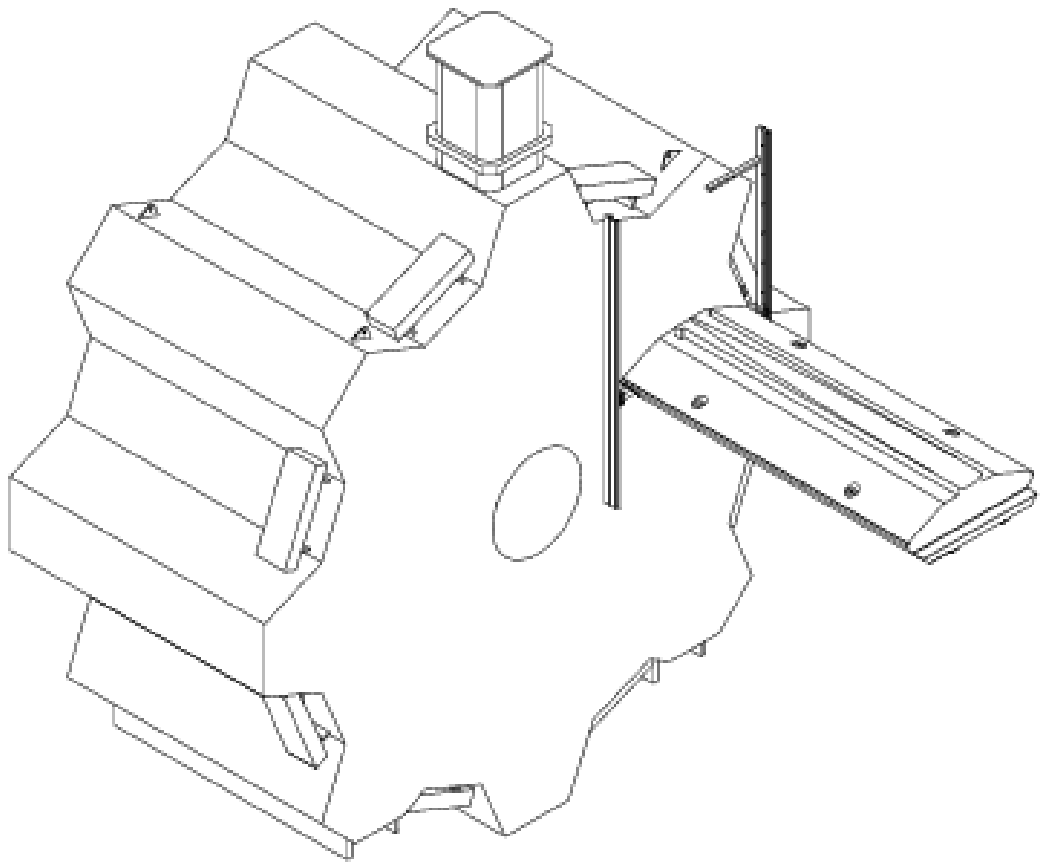

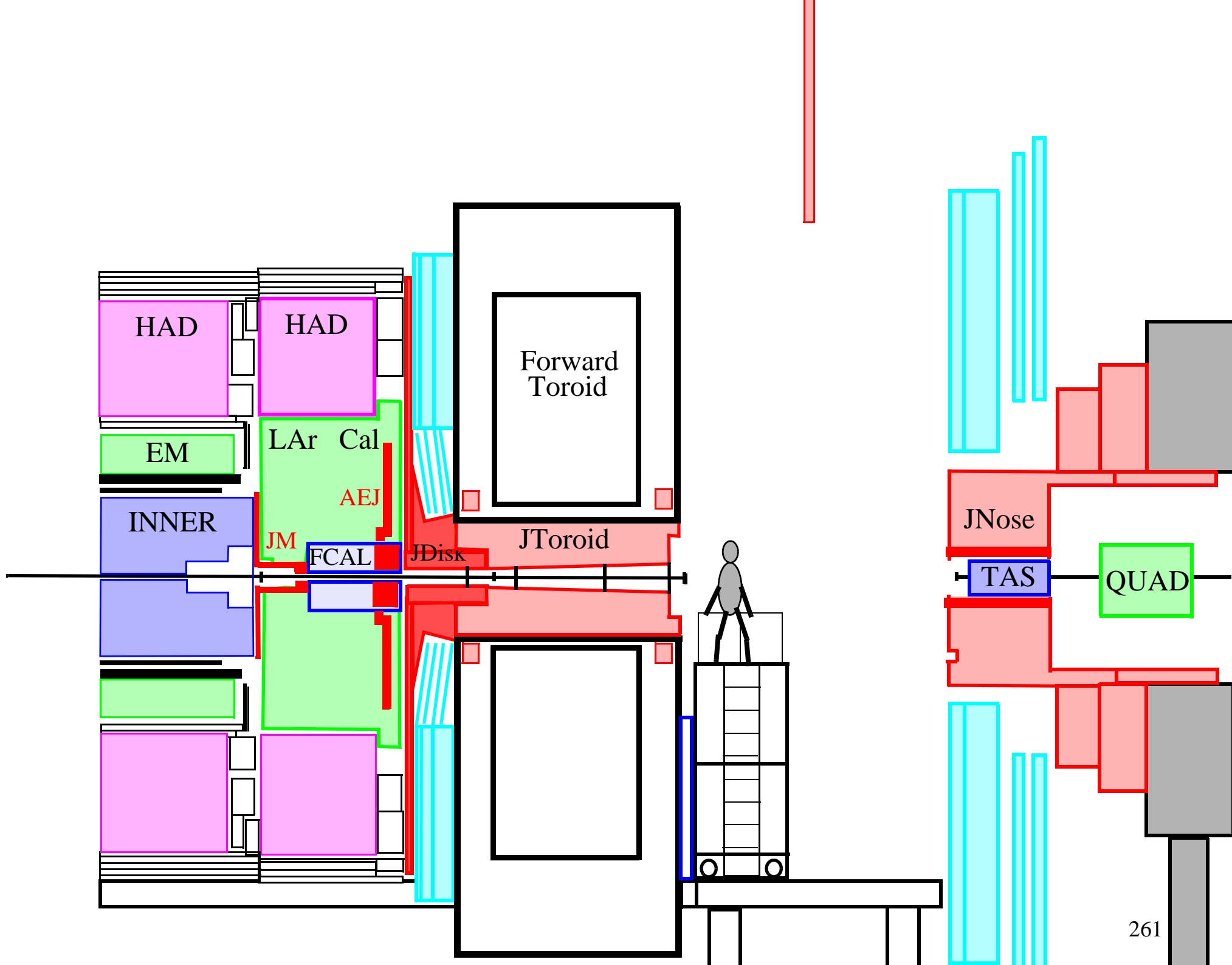

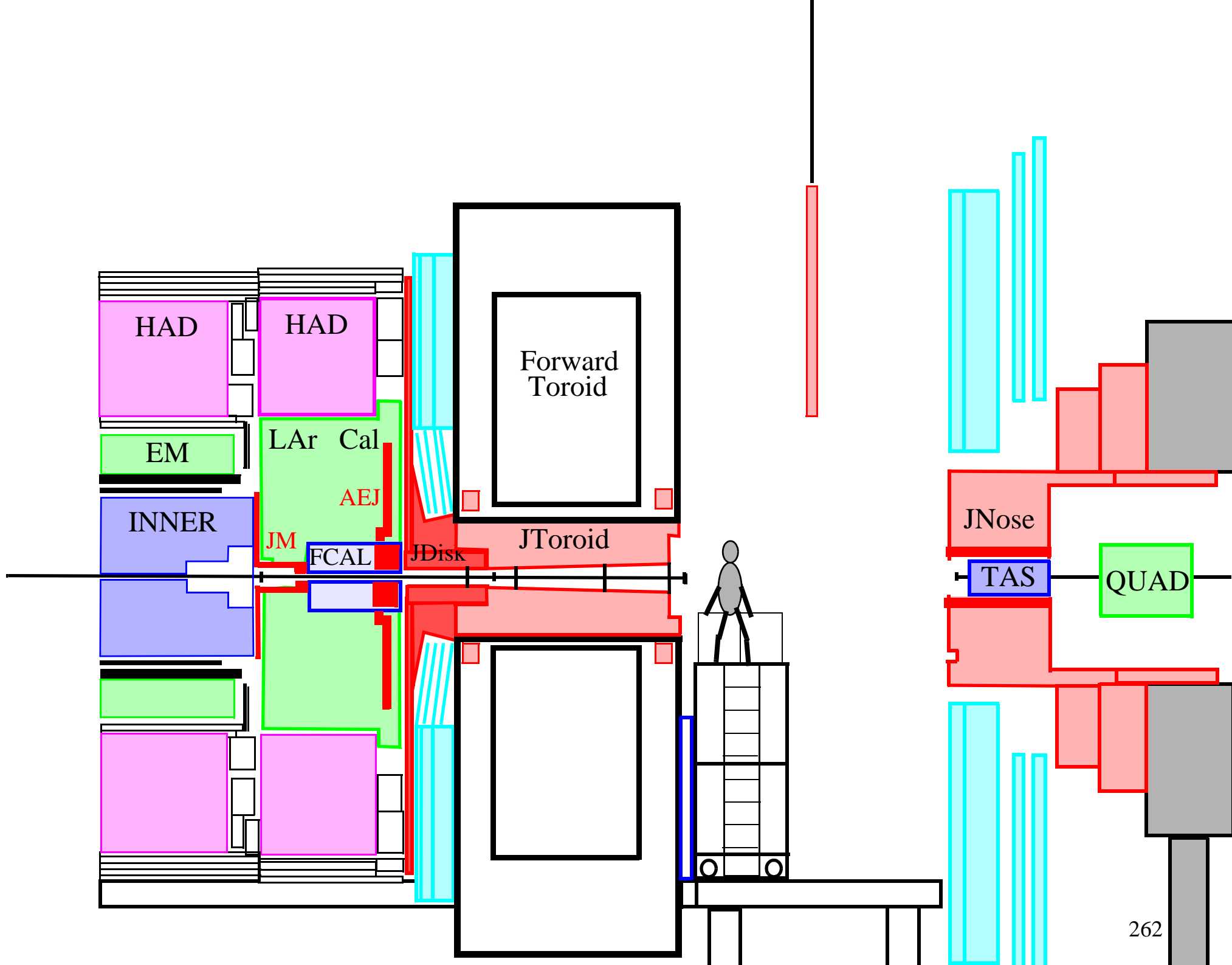

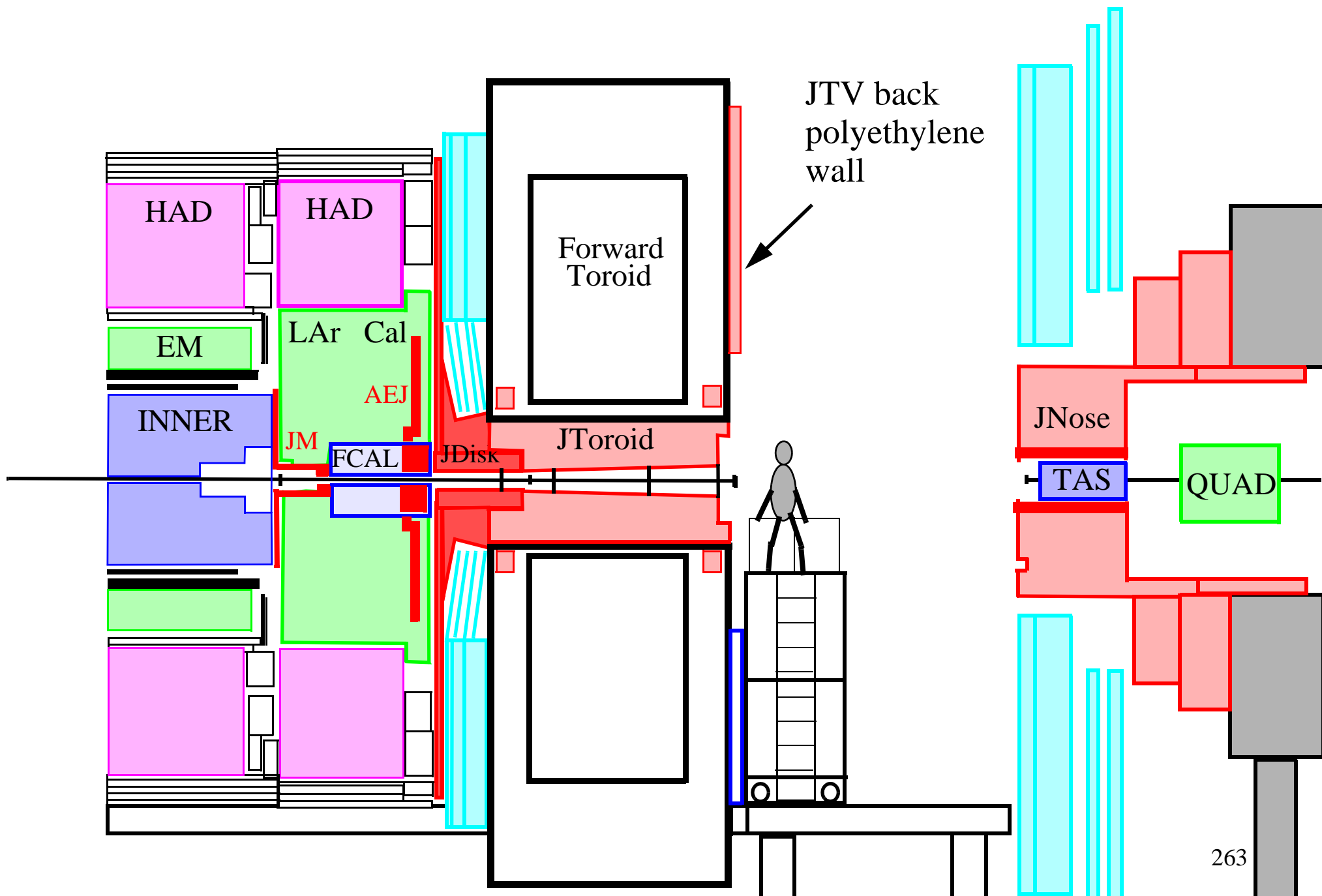

HAD

HAD

EM

LAr Cal

INNER

AEJ

JM

FCAL

JDisk

Forward
Toroid

JToroid

JTV back
polyethylene
wall

JNose

TAS

QUAD

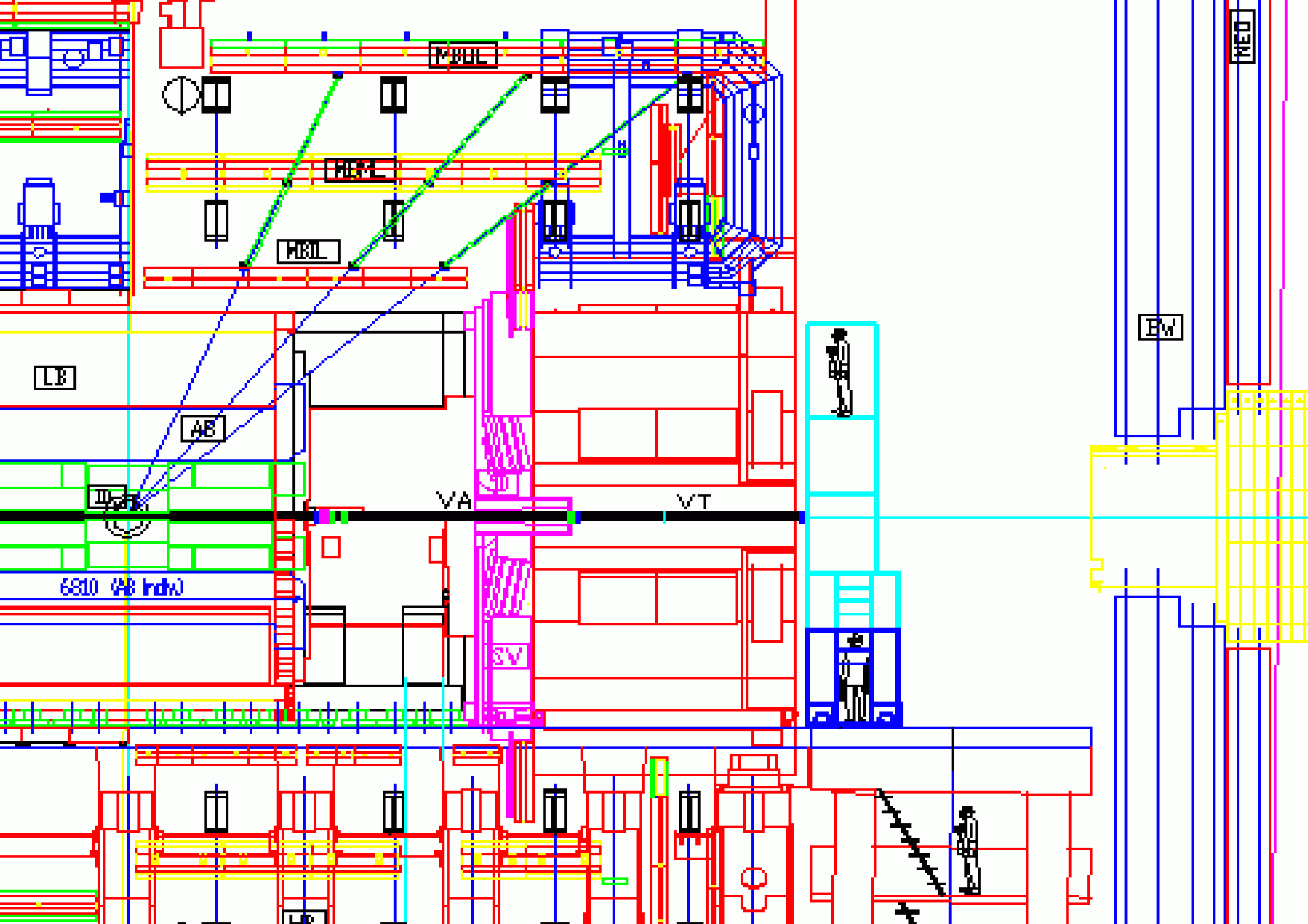

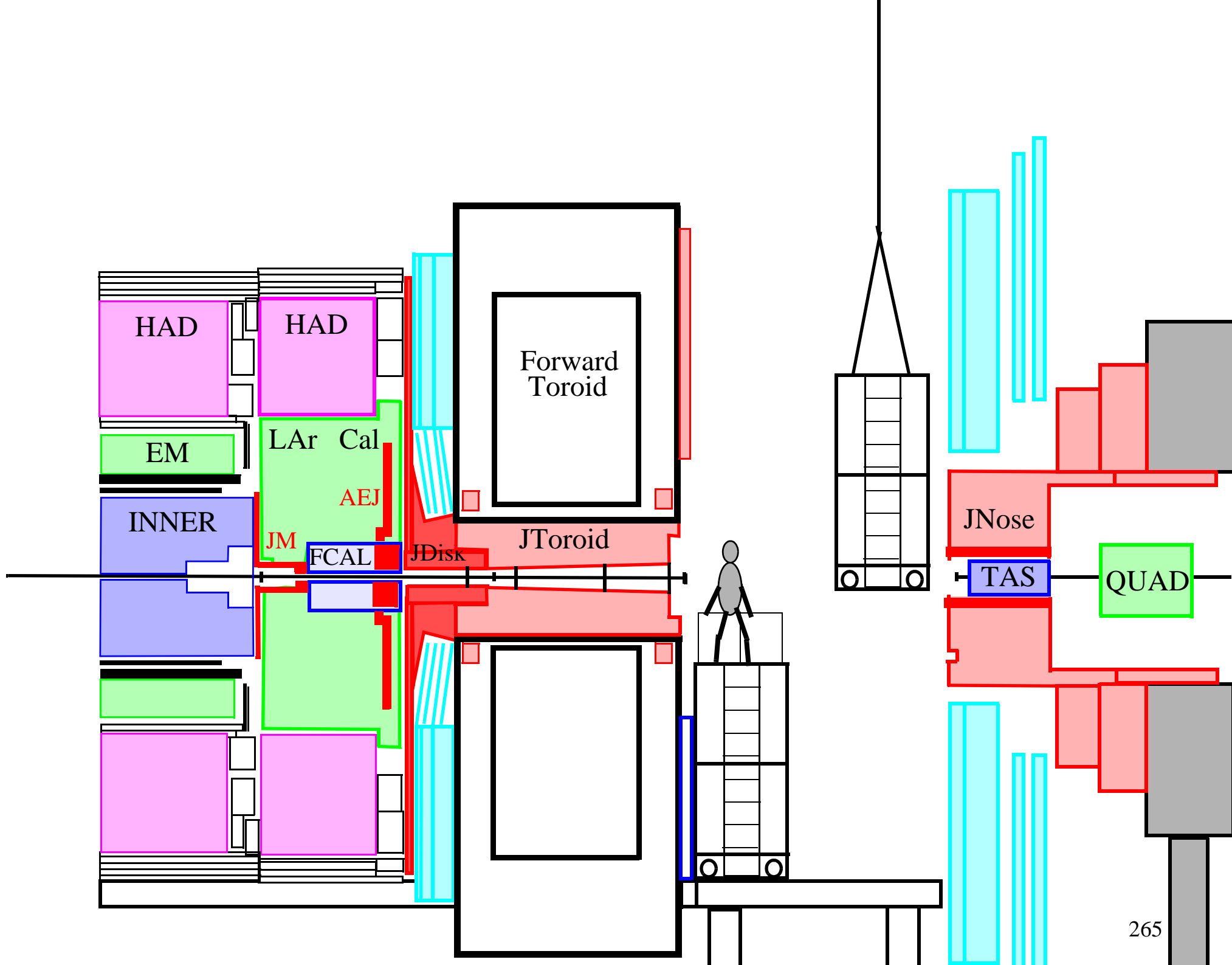

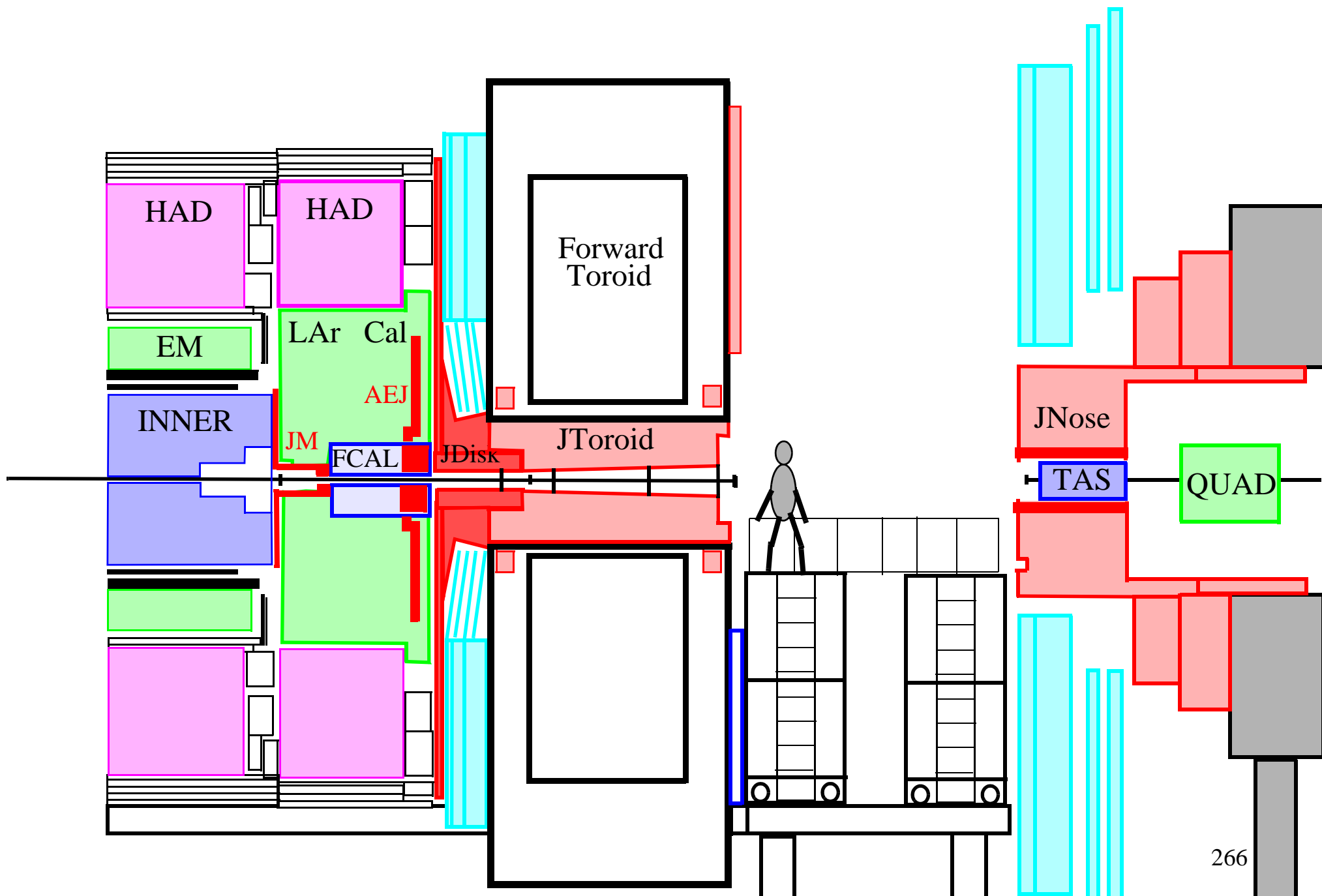

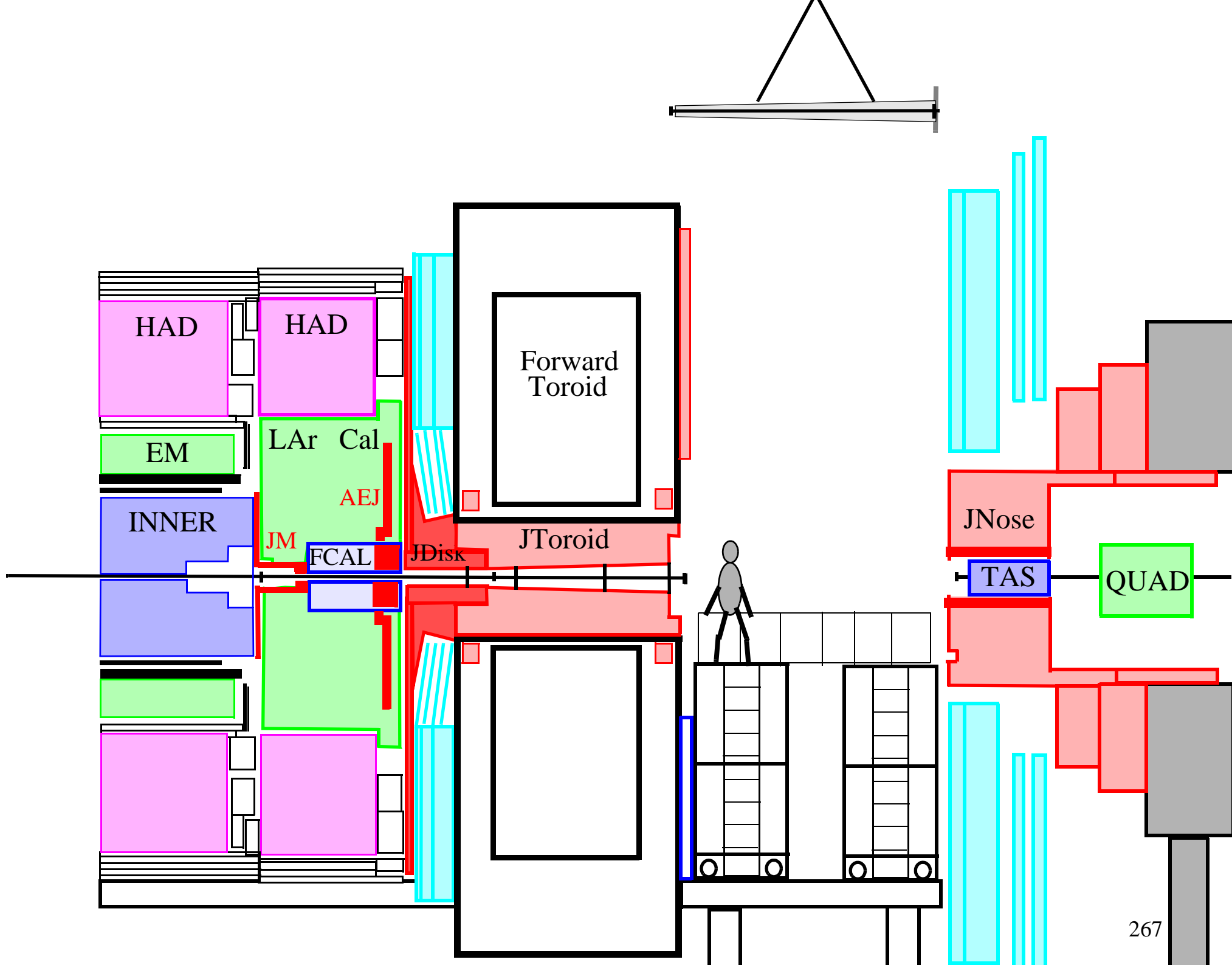

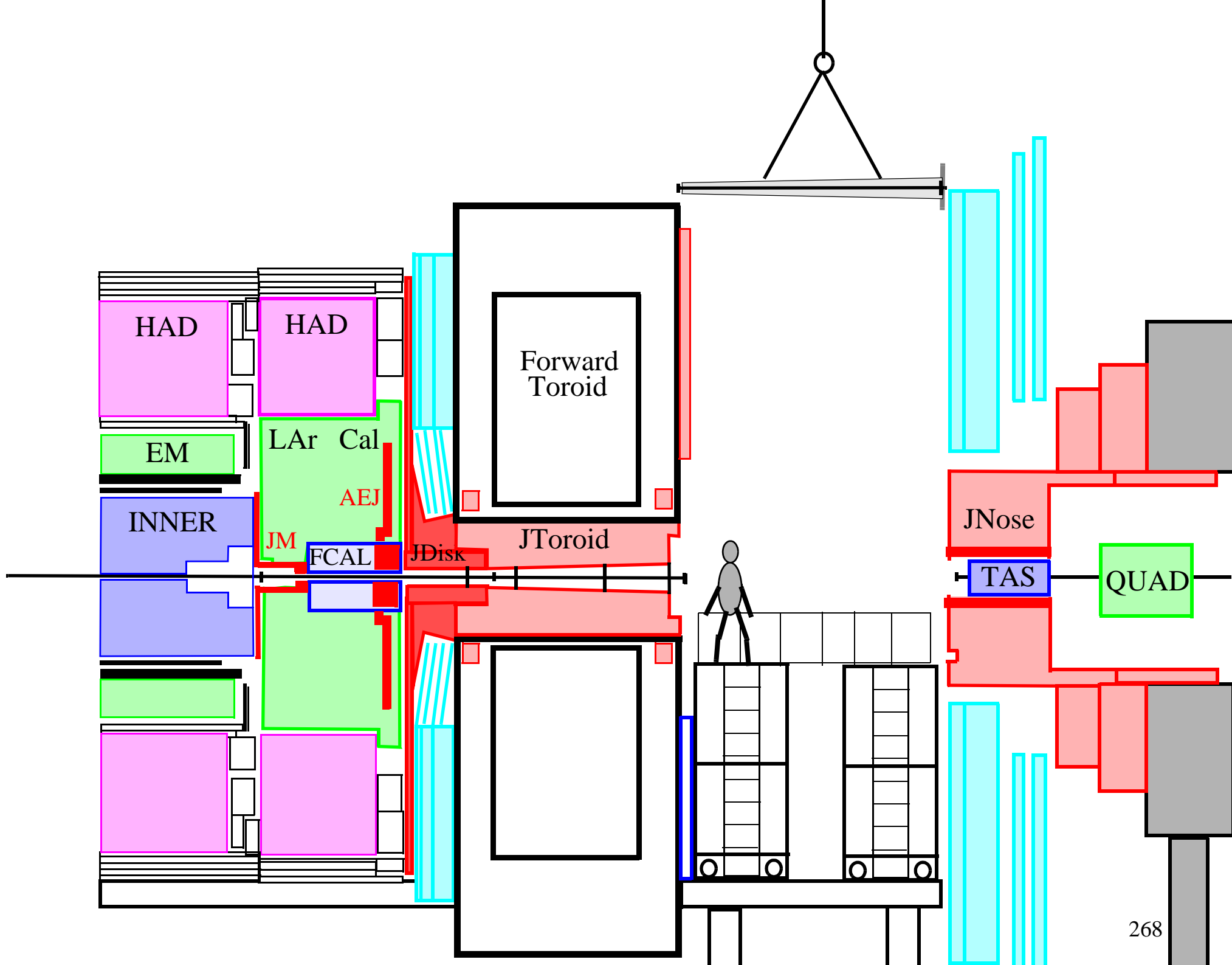

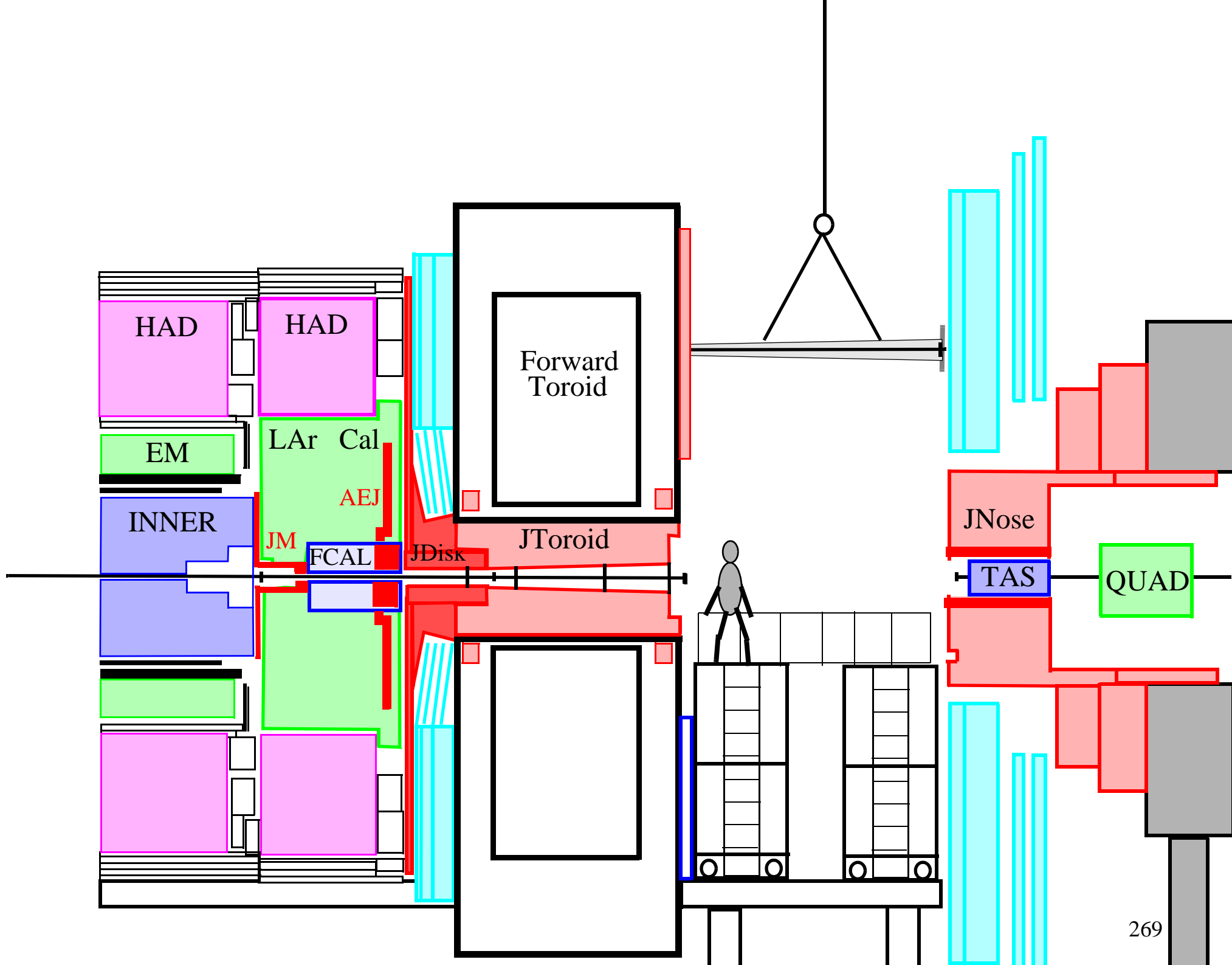

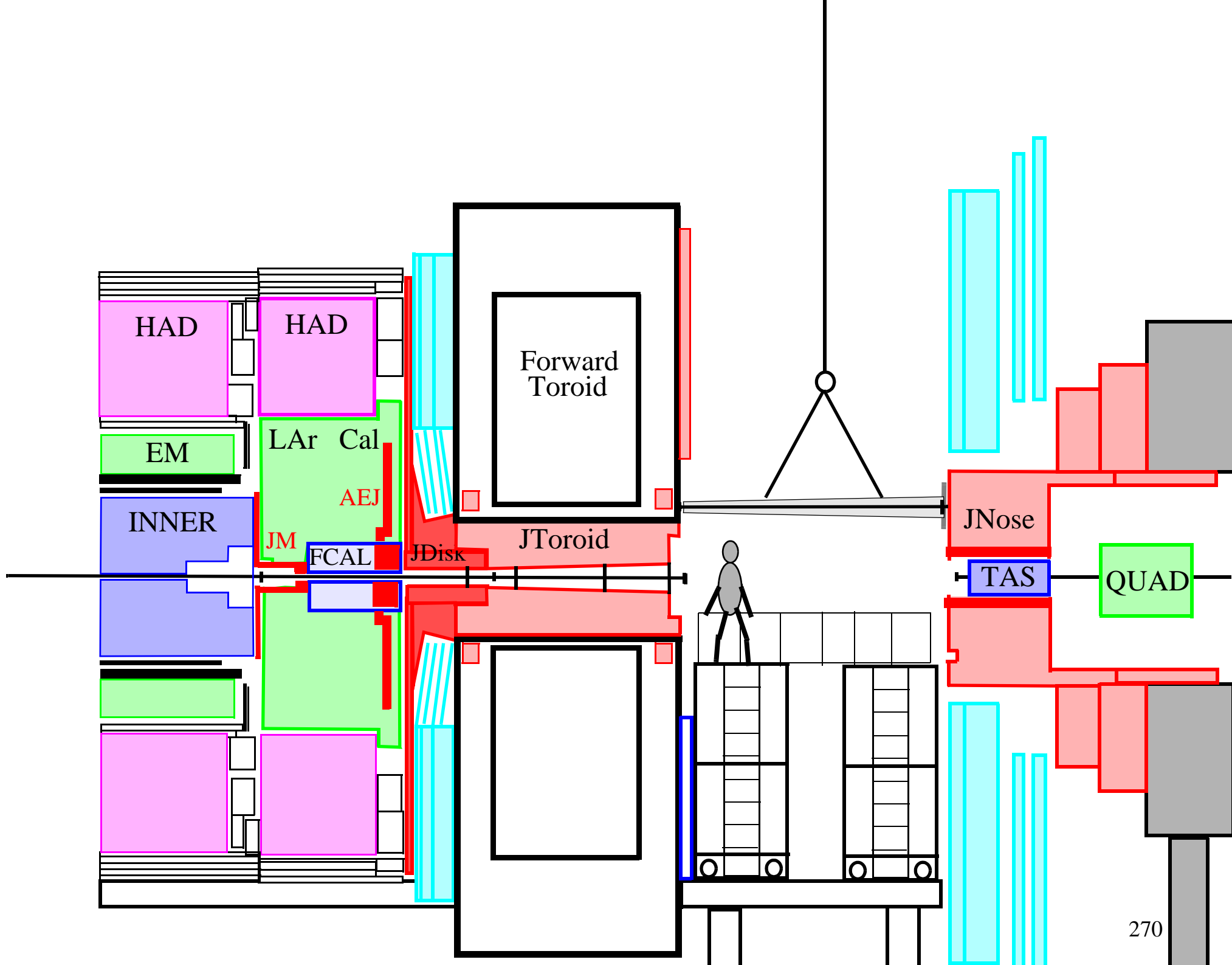

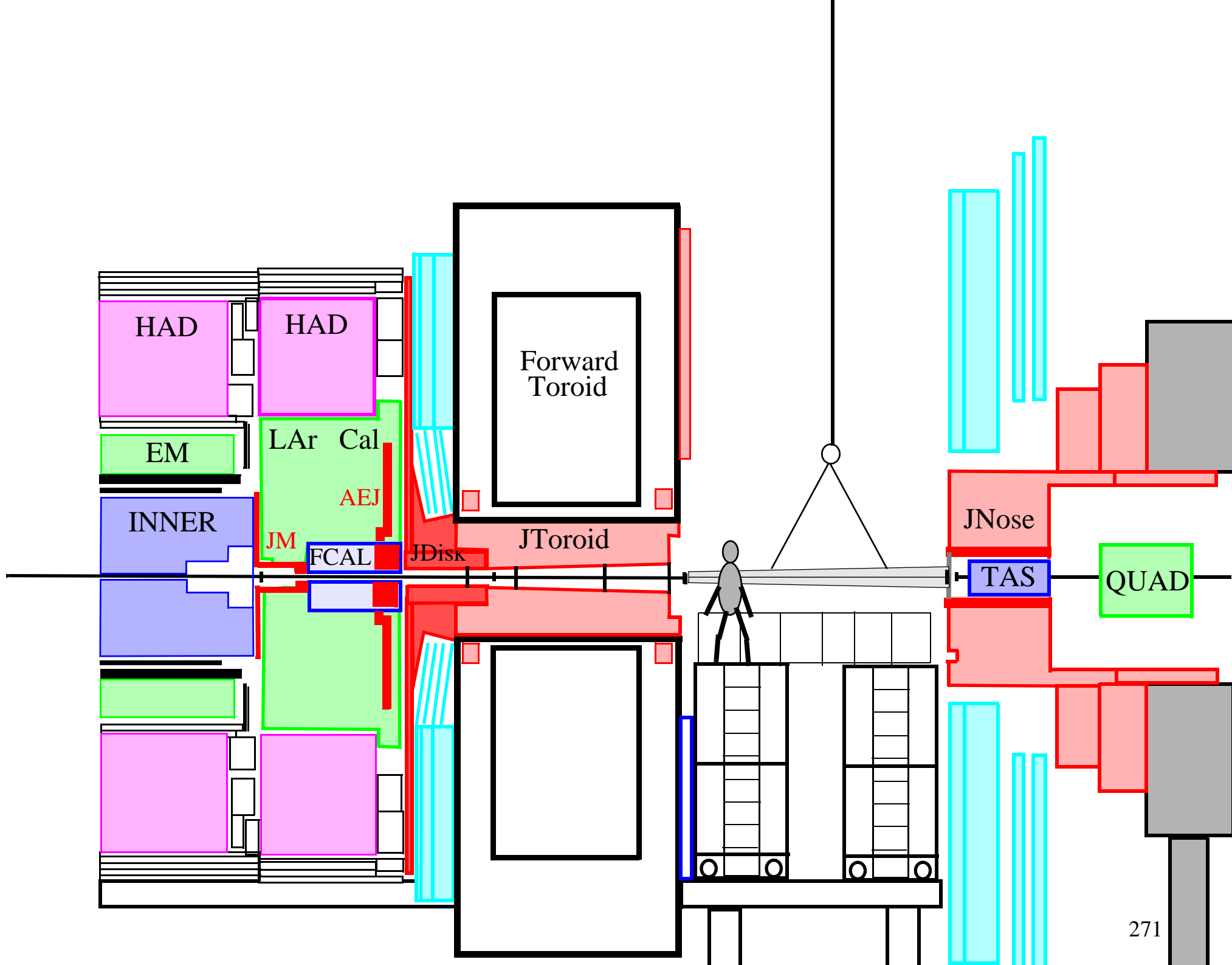

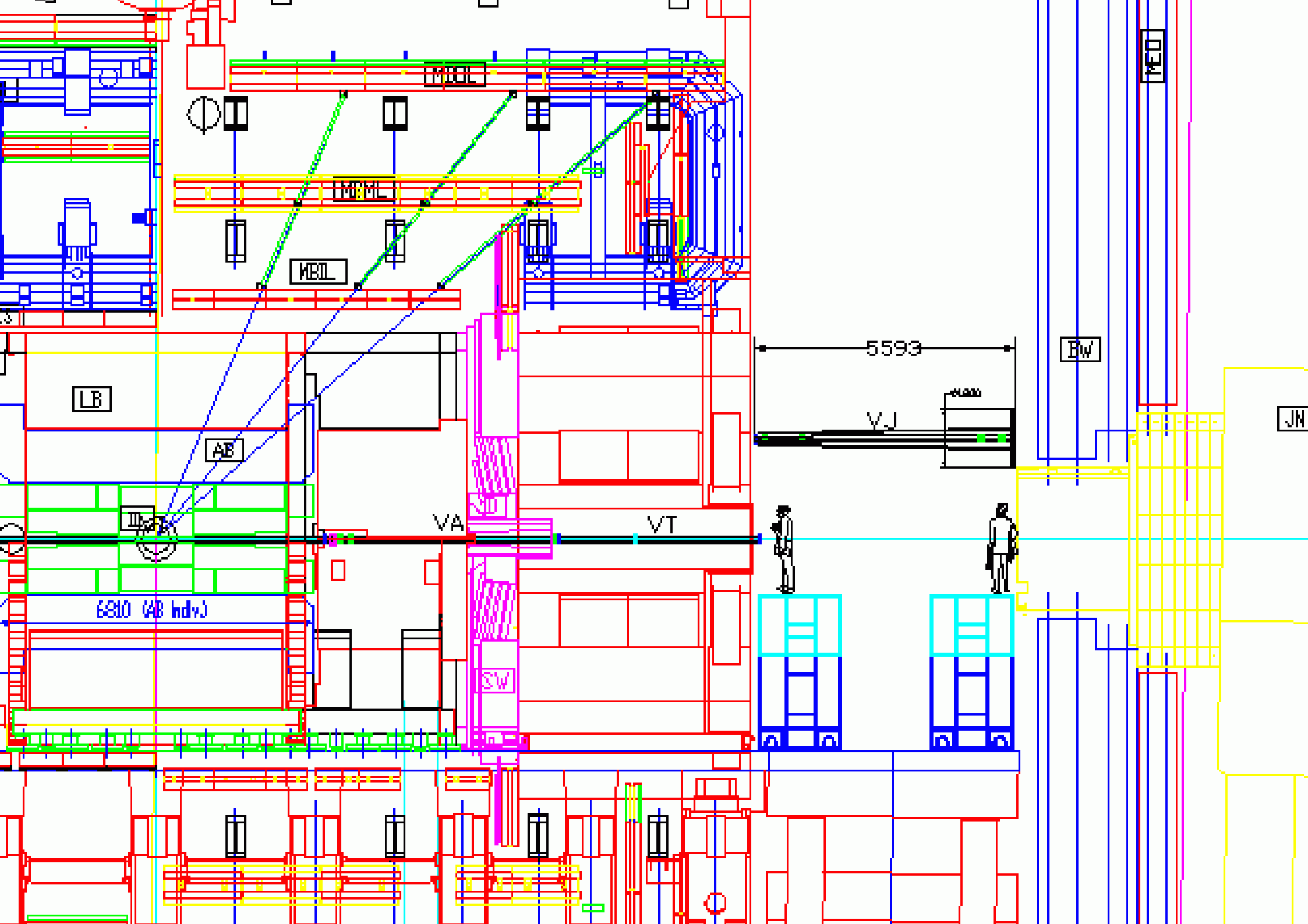

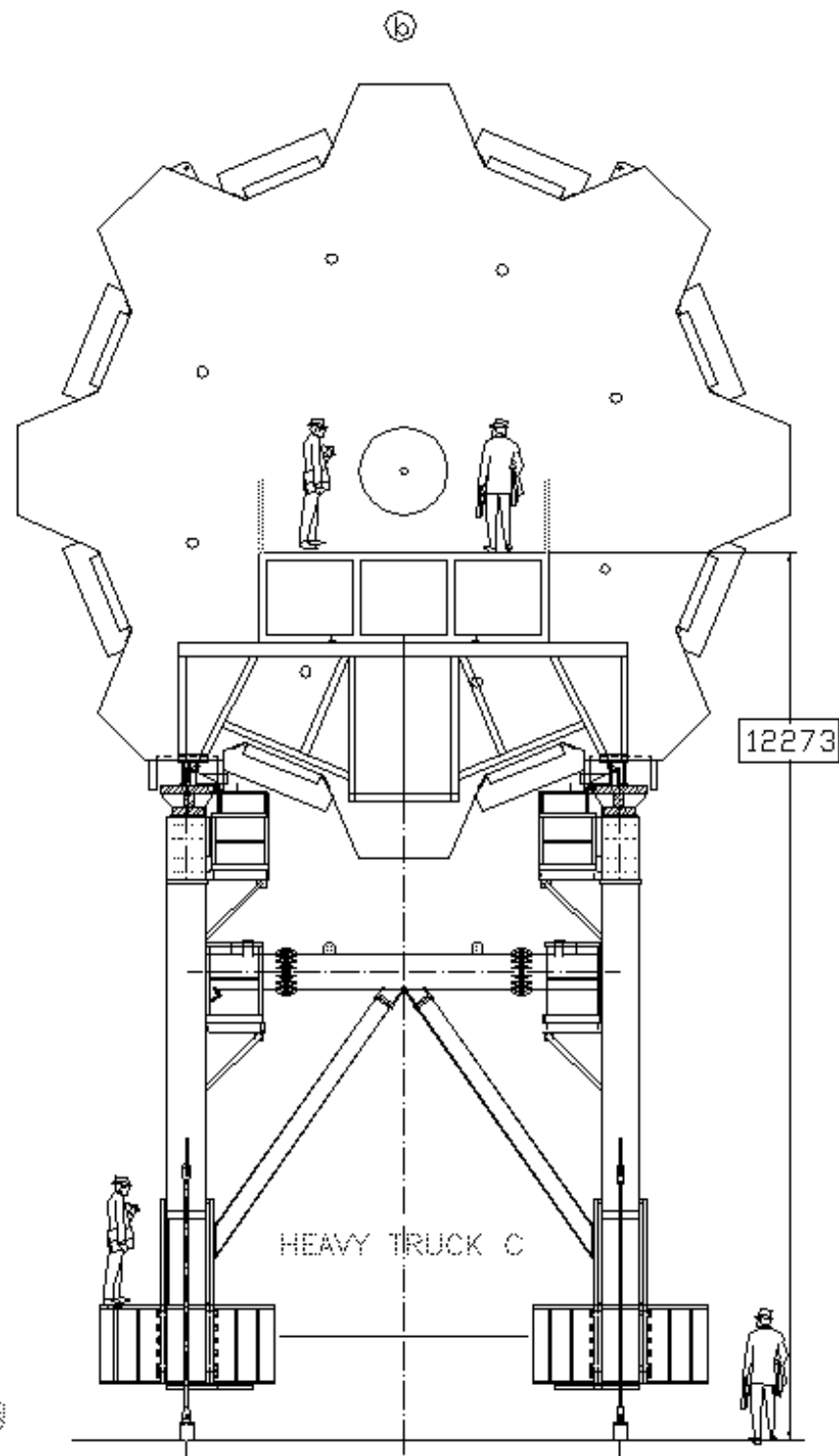

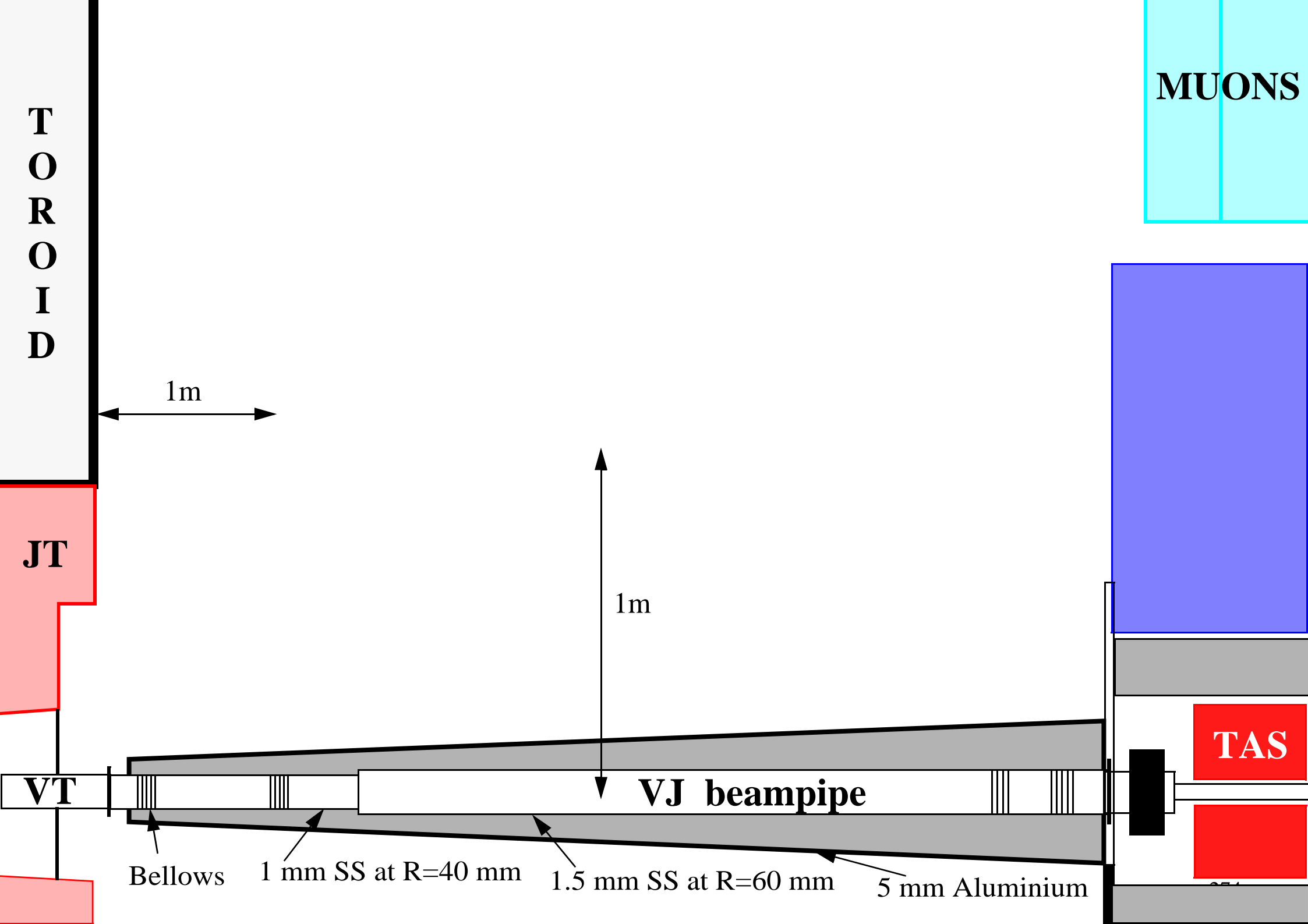

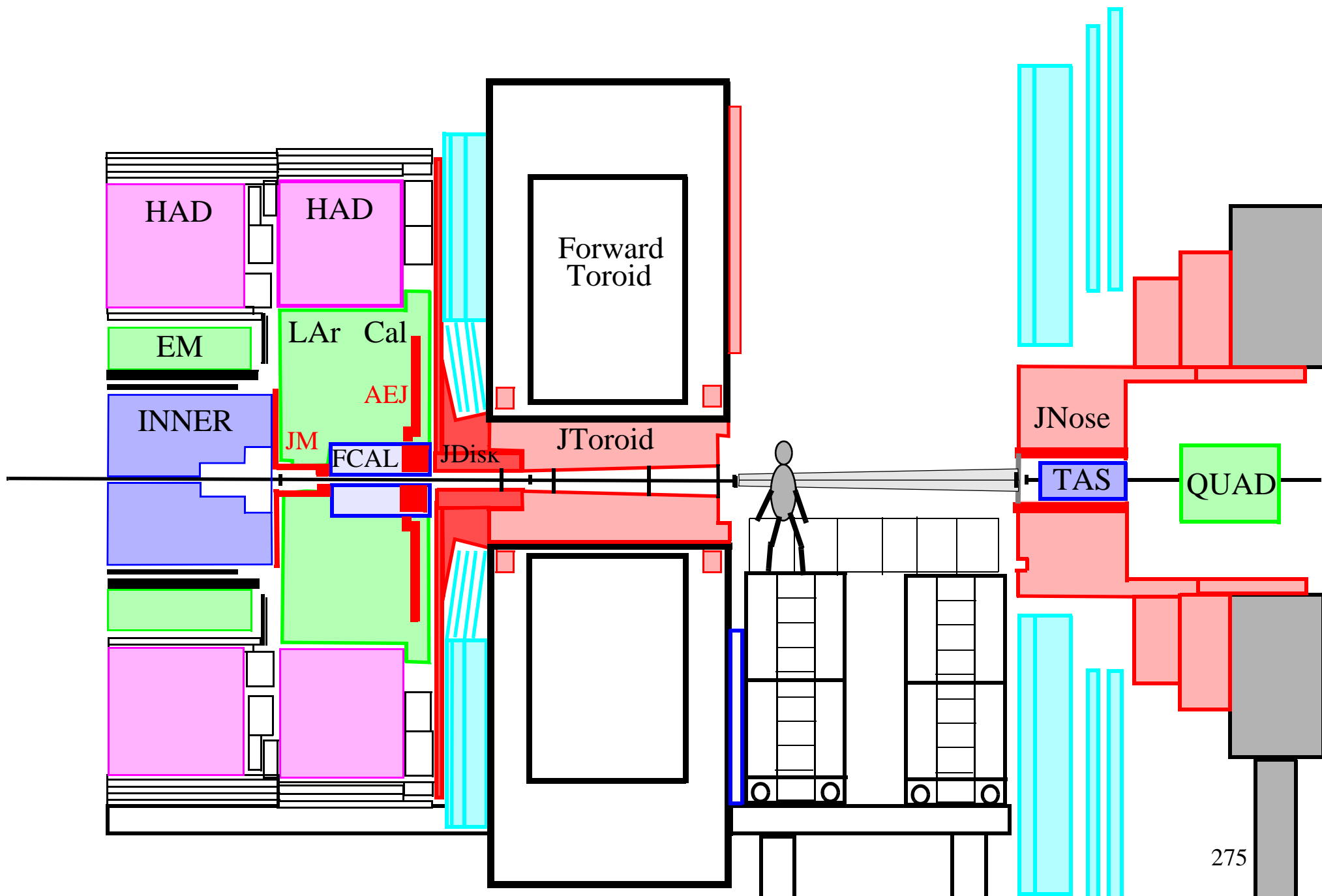

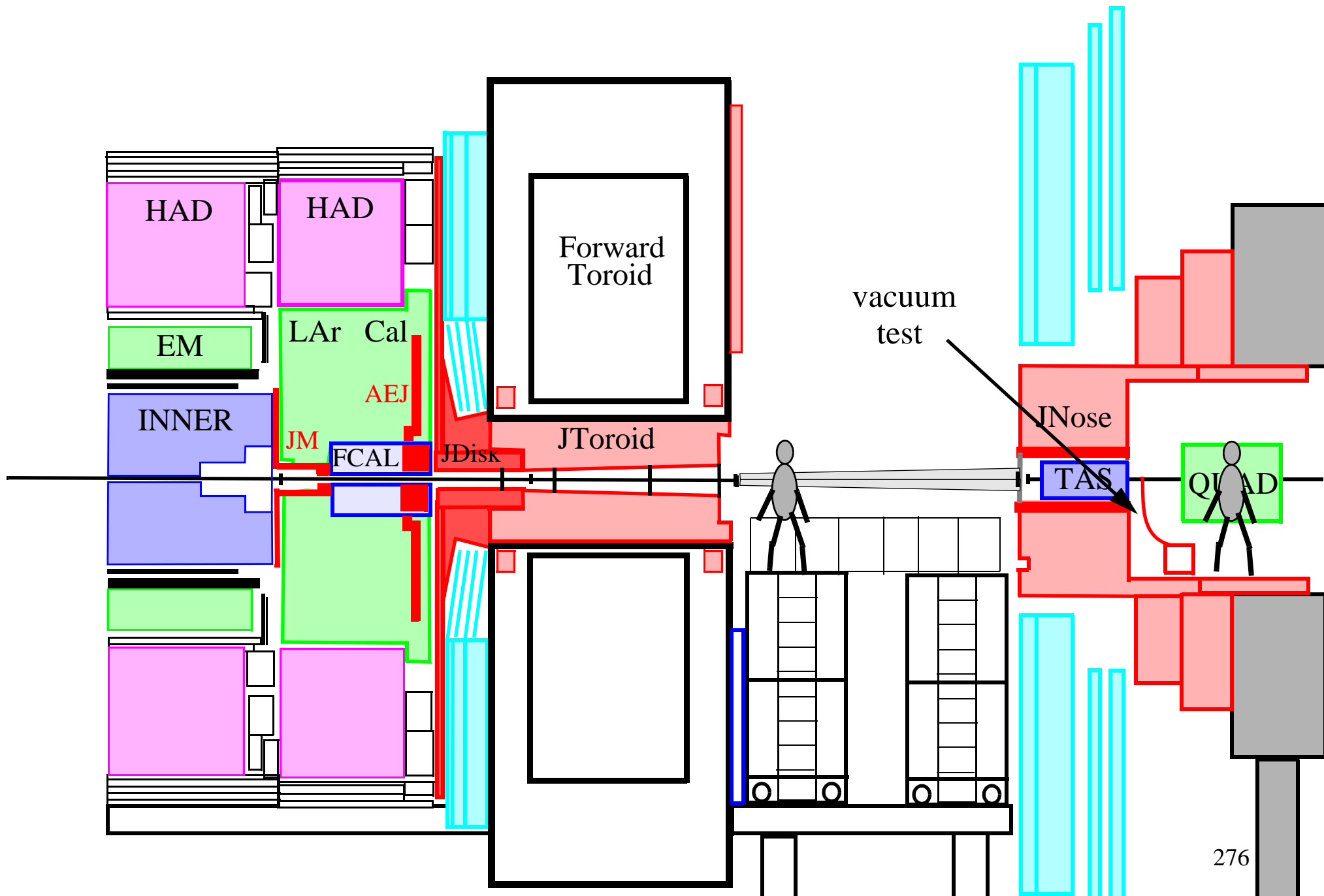

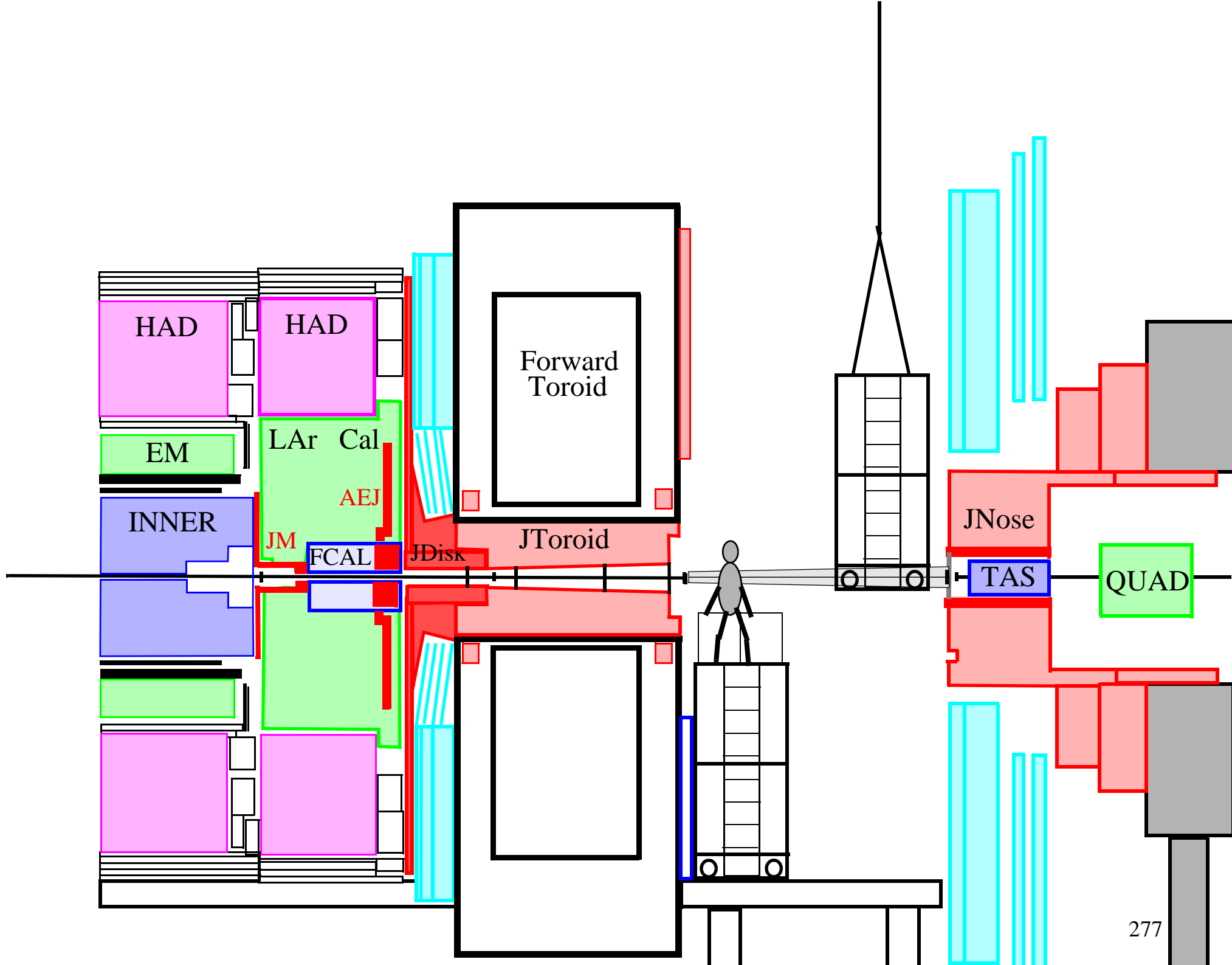

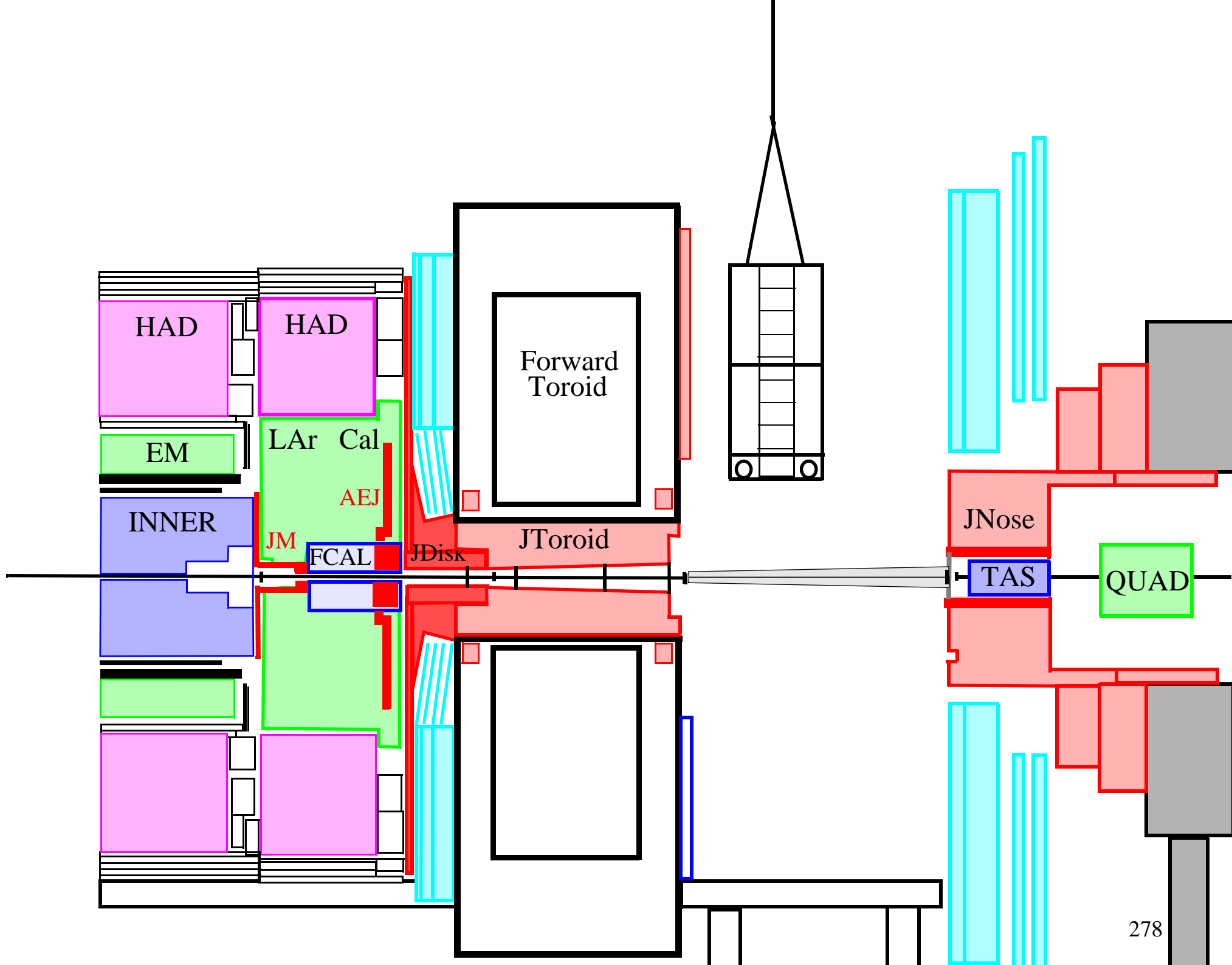

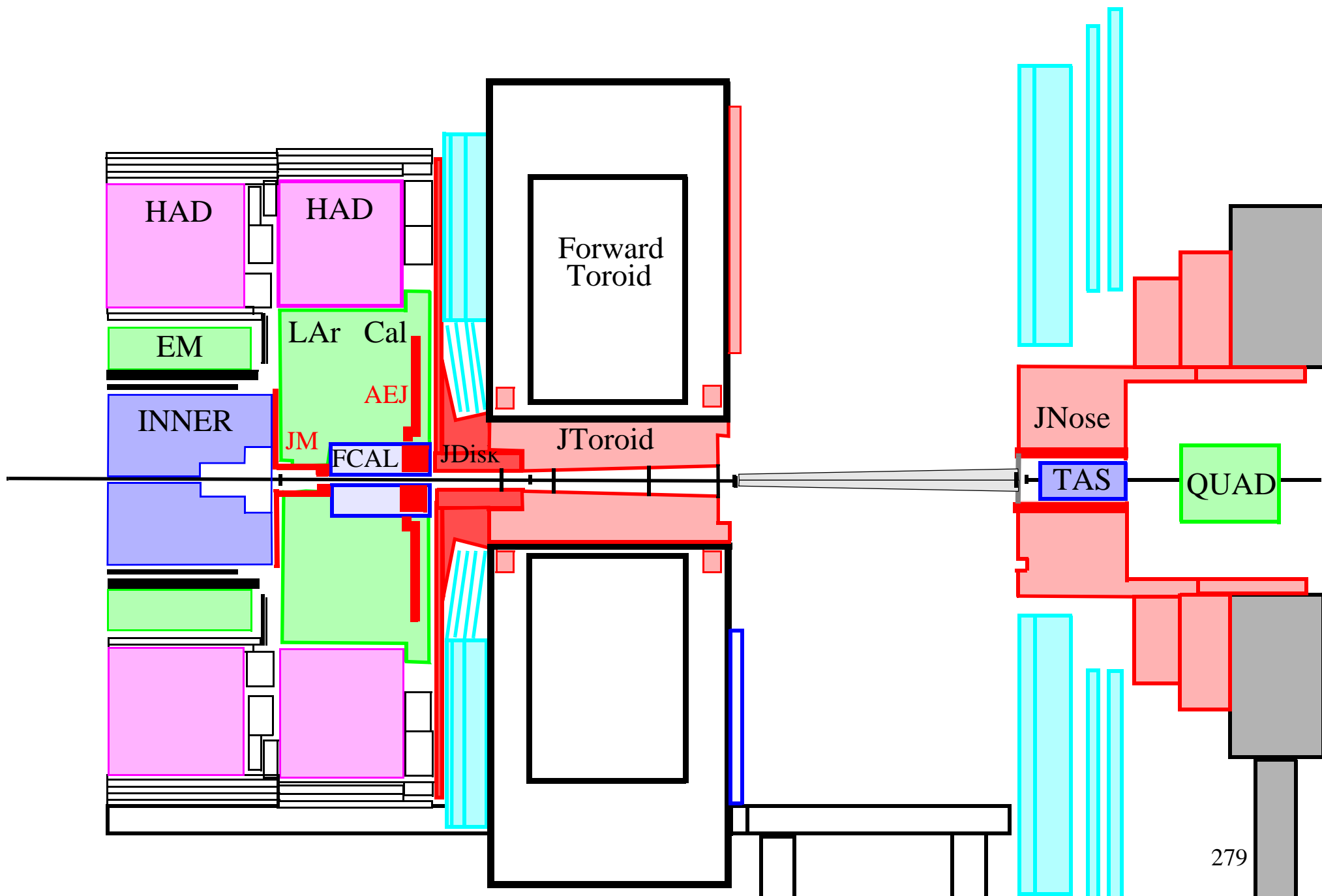

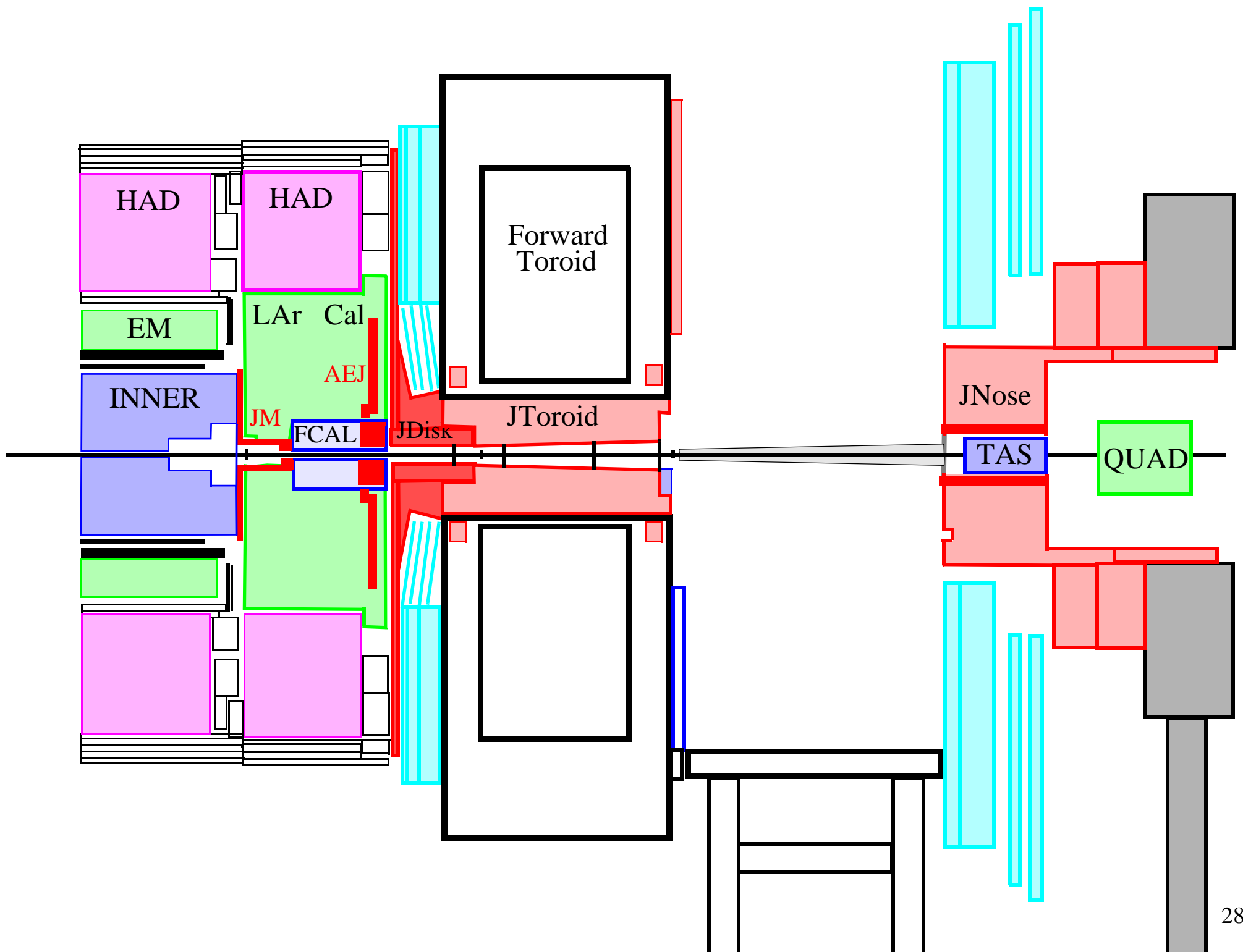

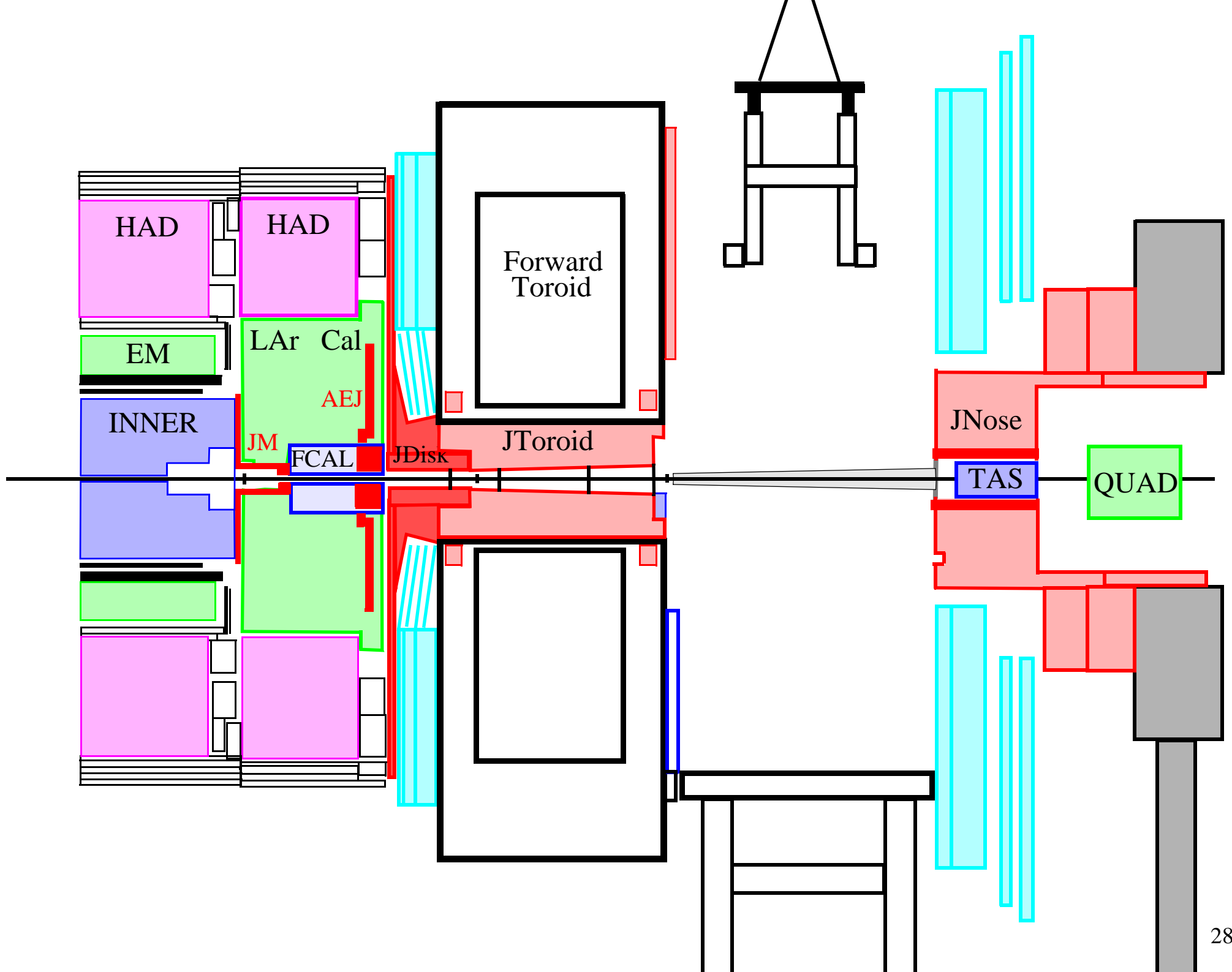

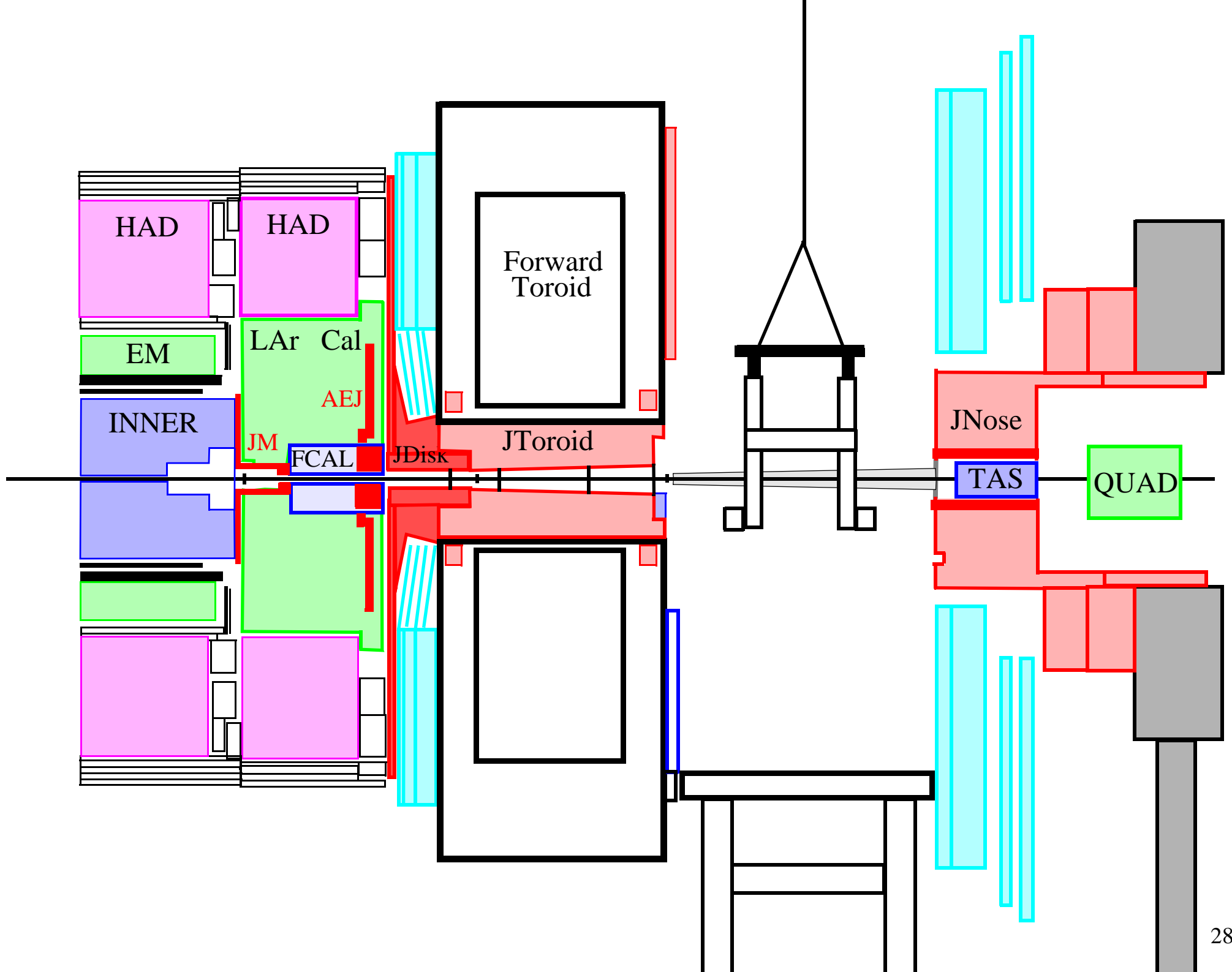

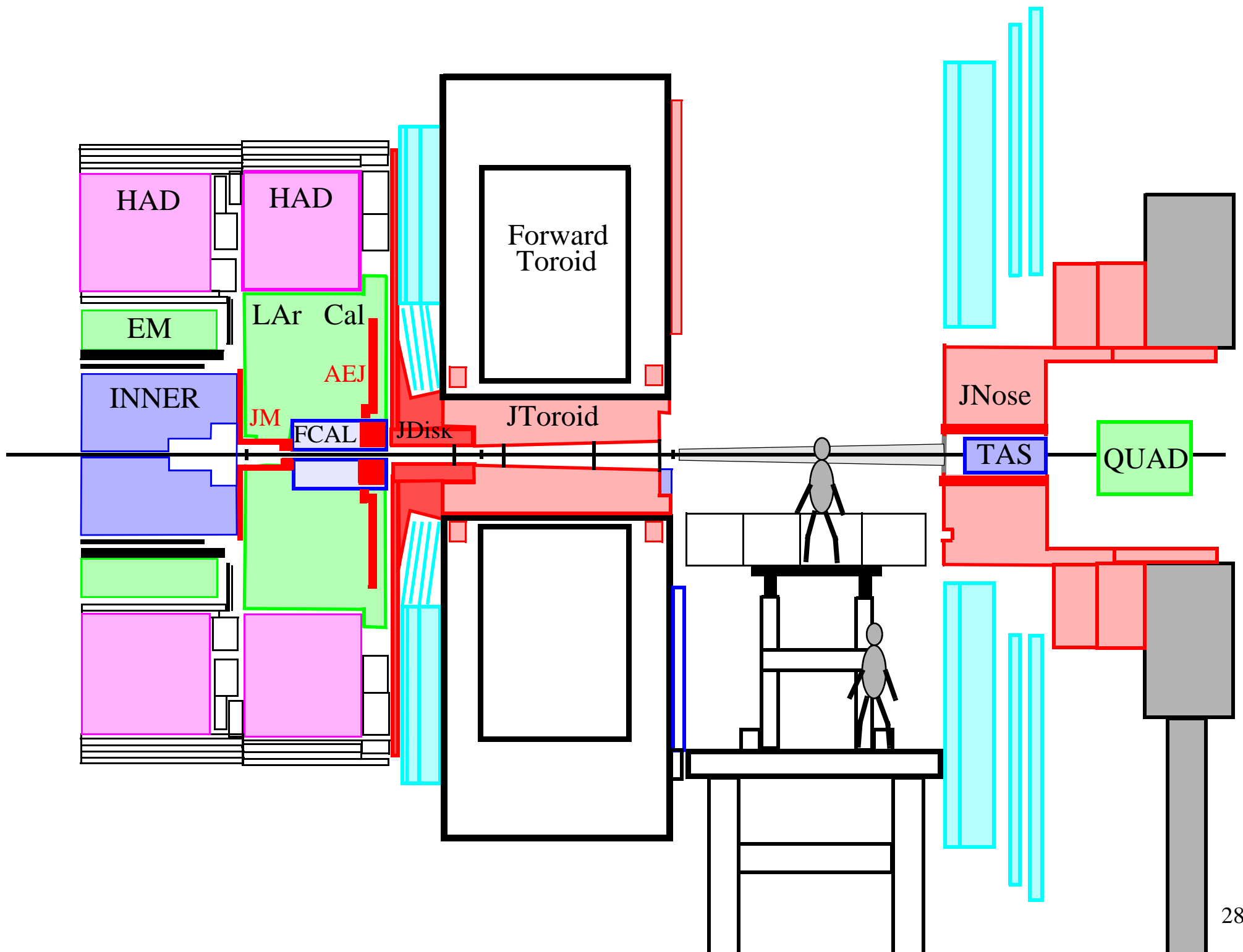

July 2007

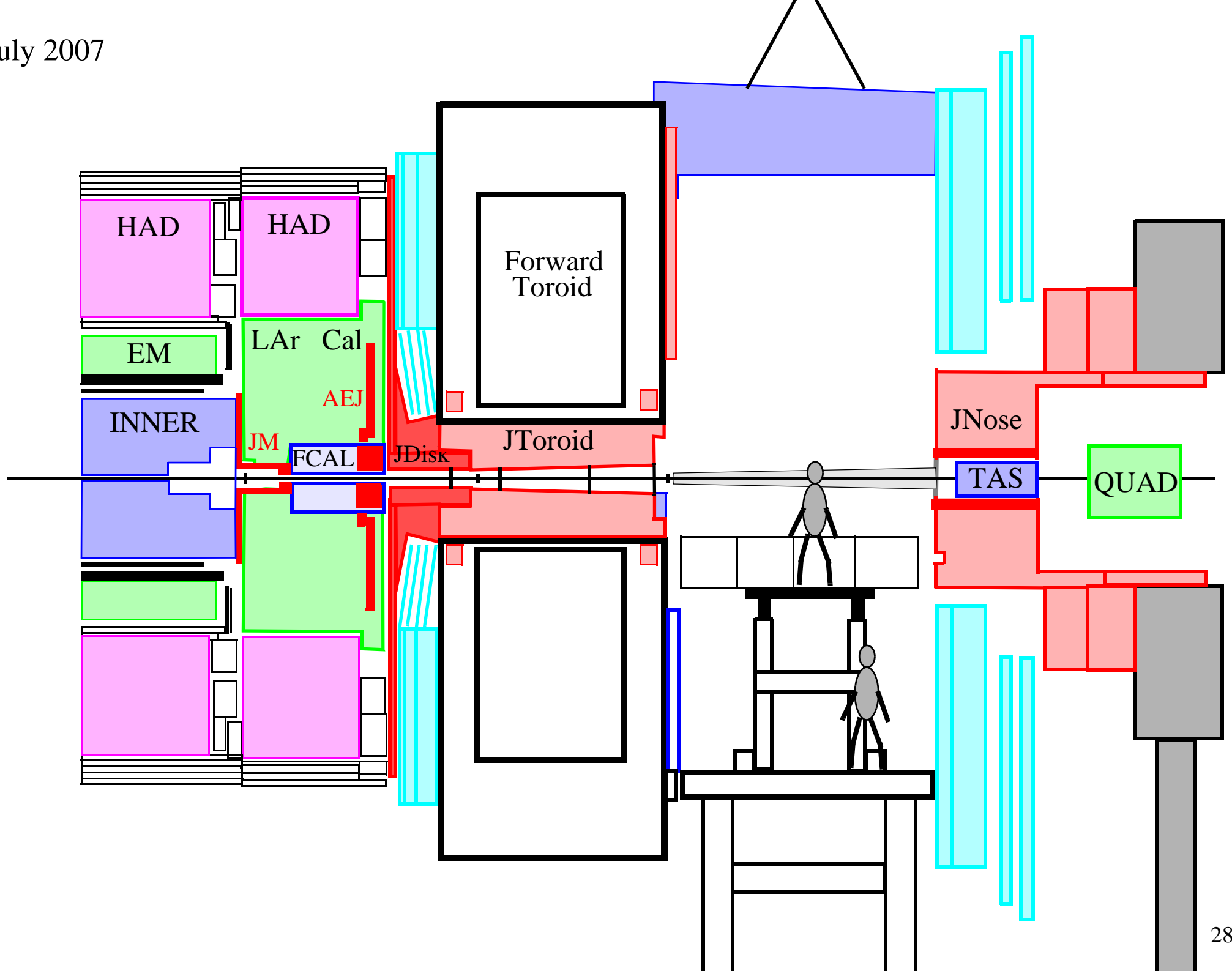

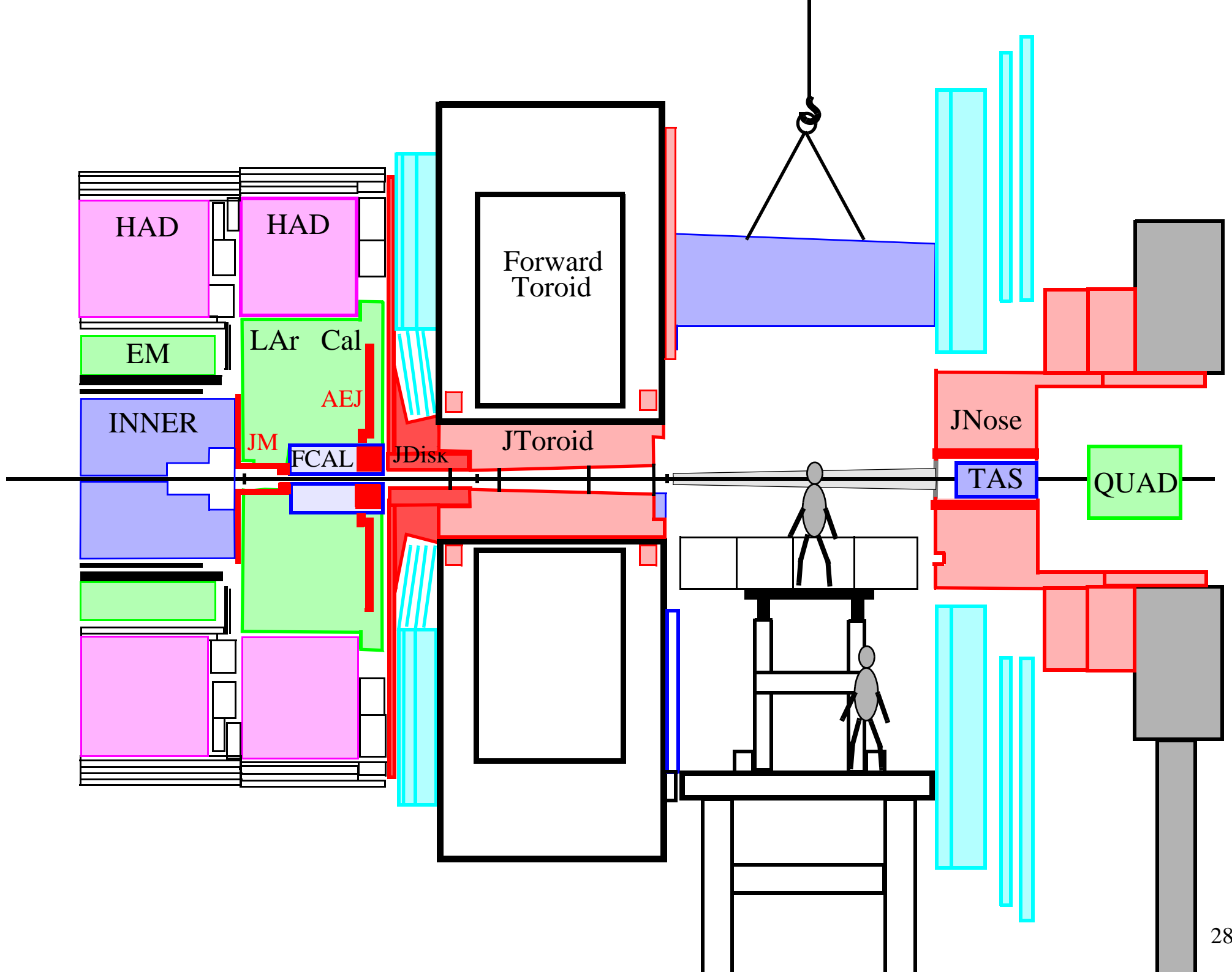

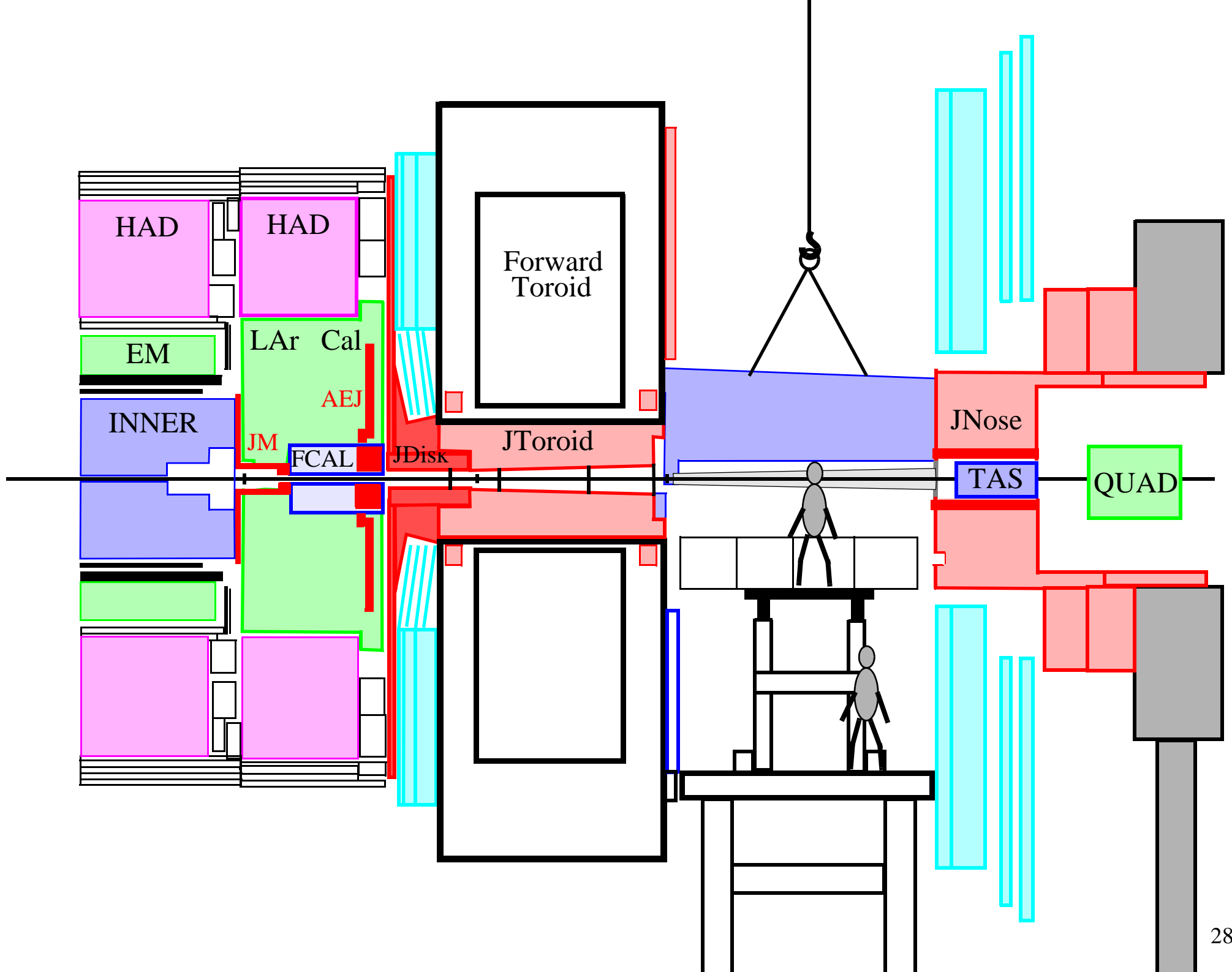

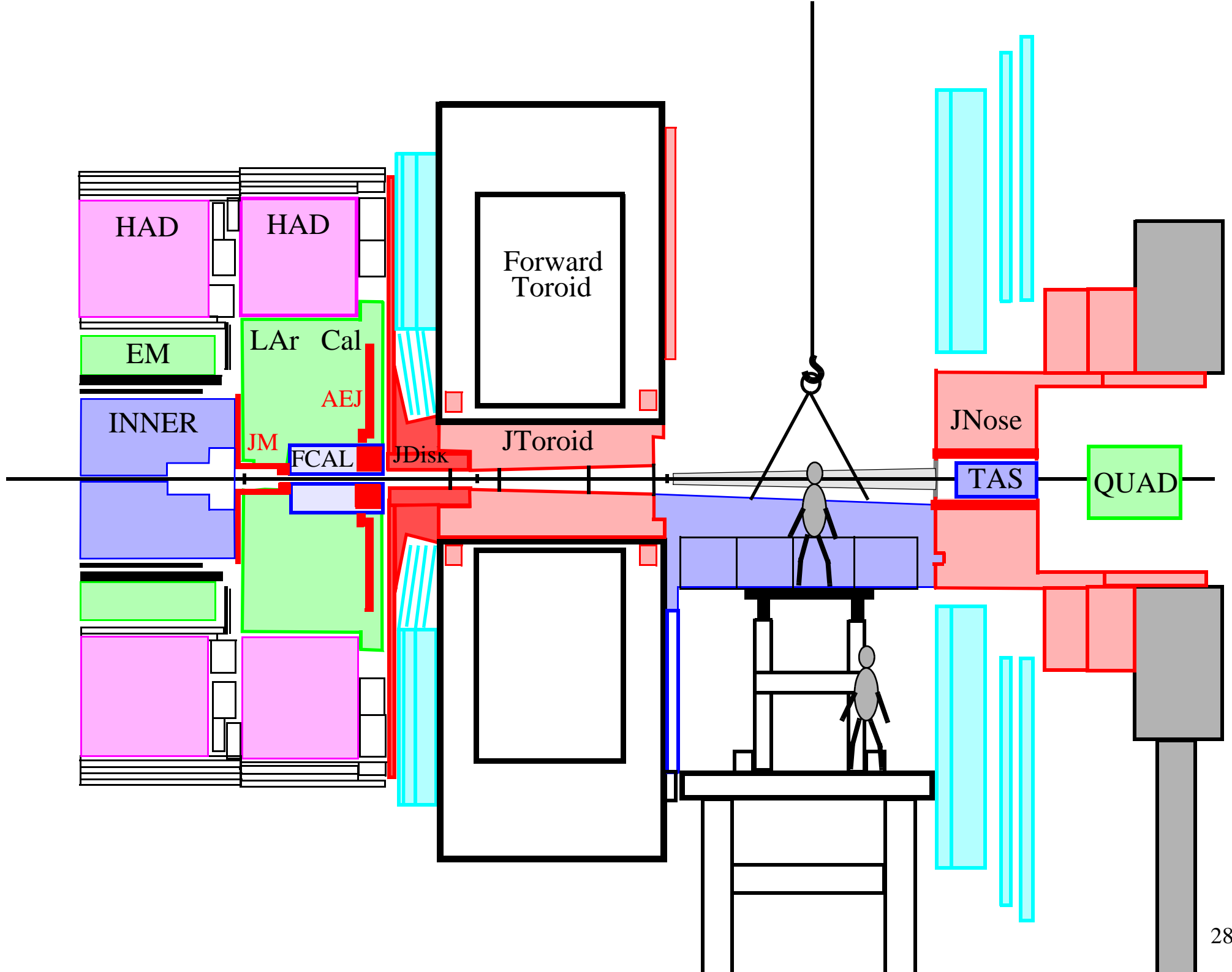

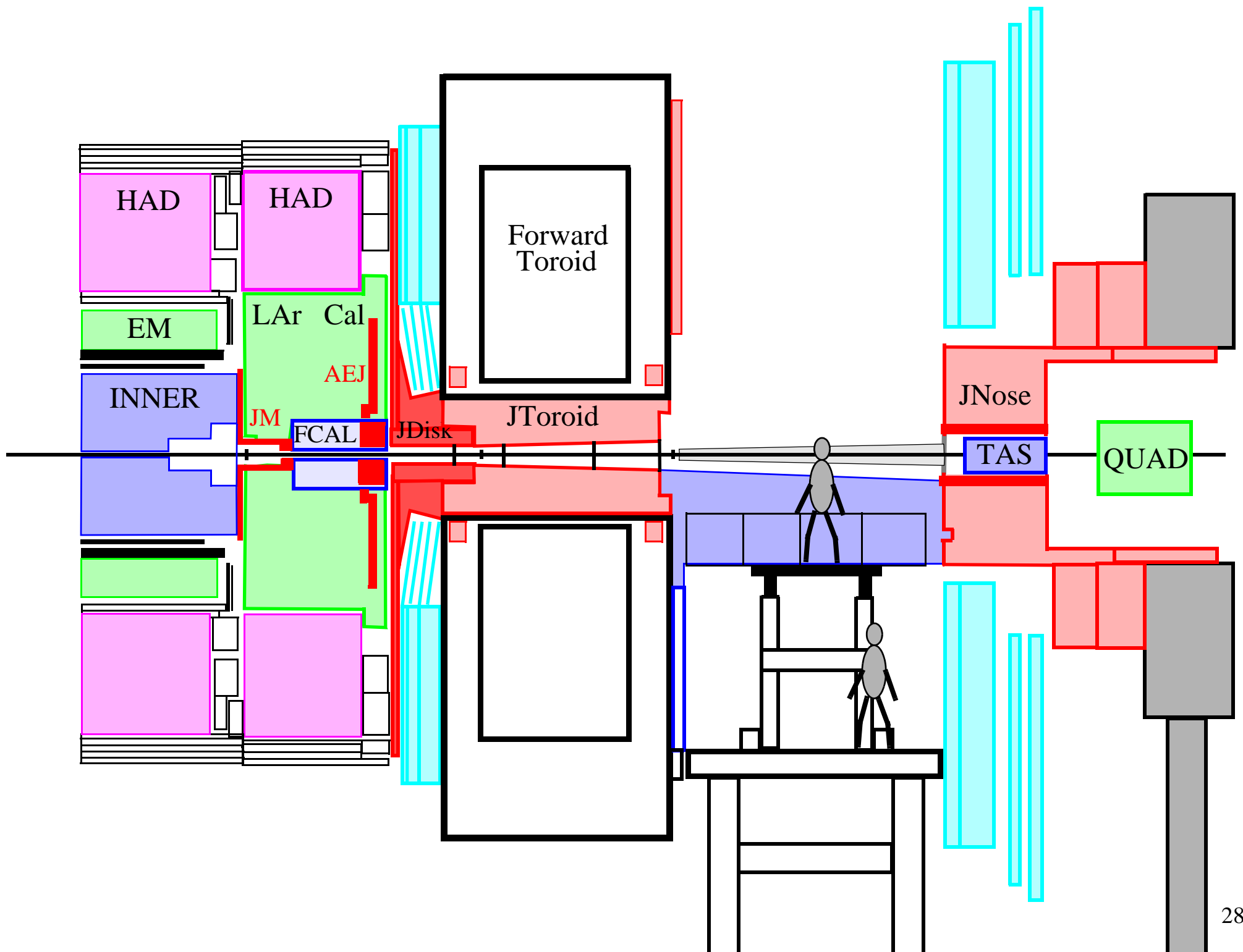

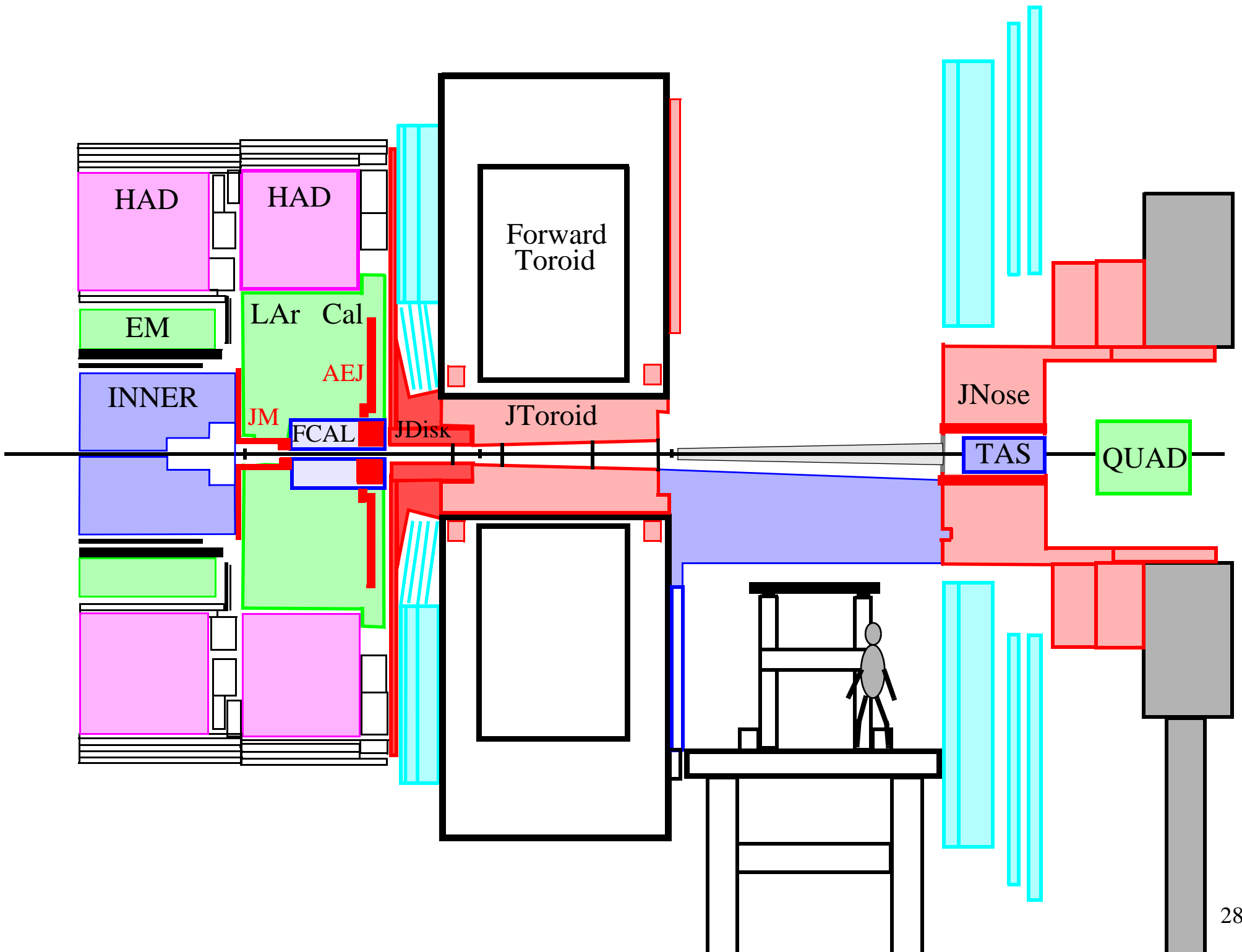

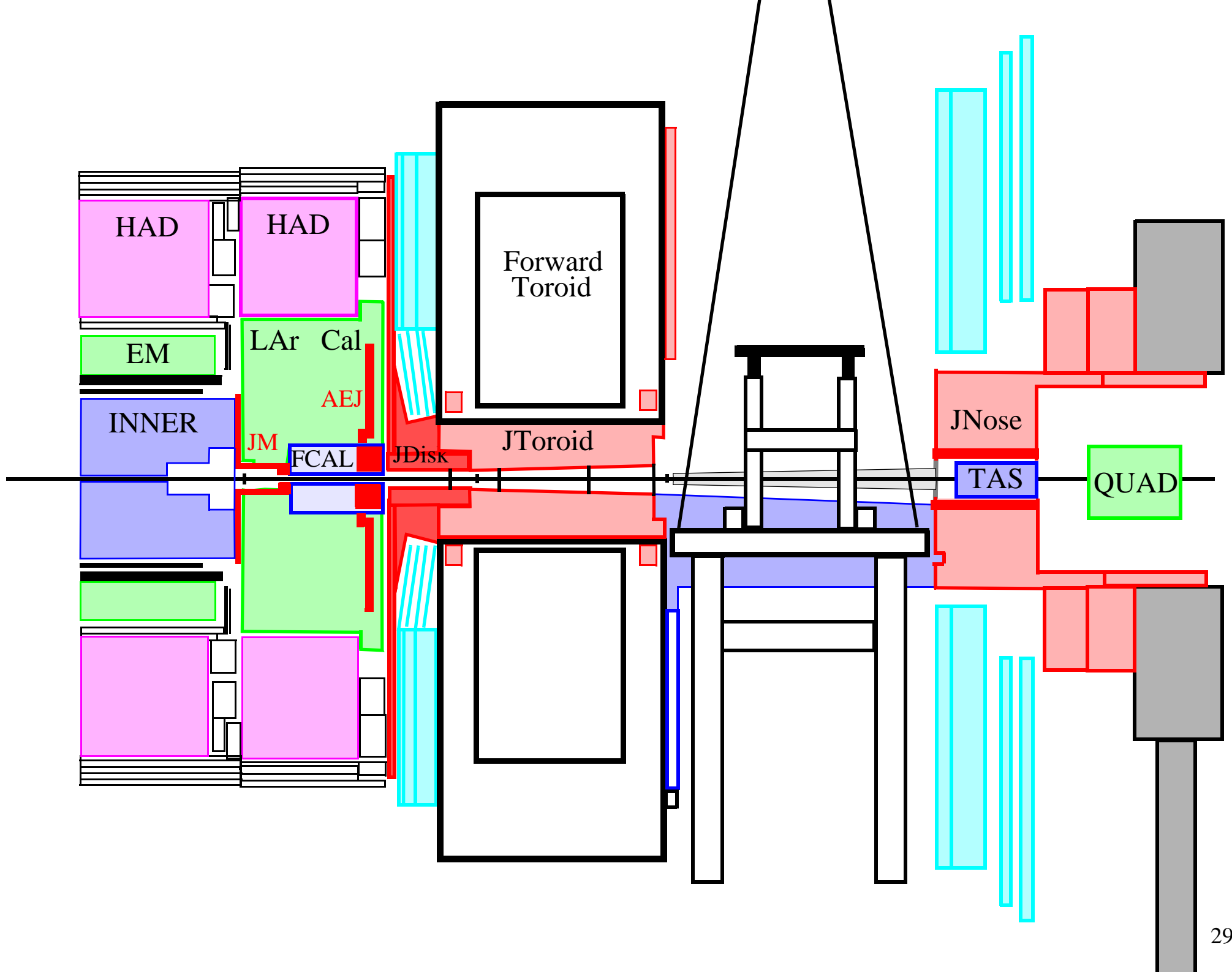

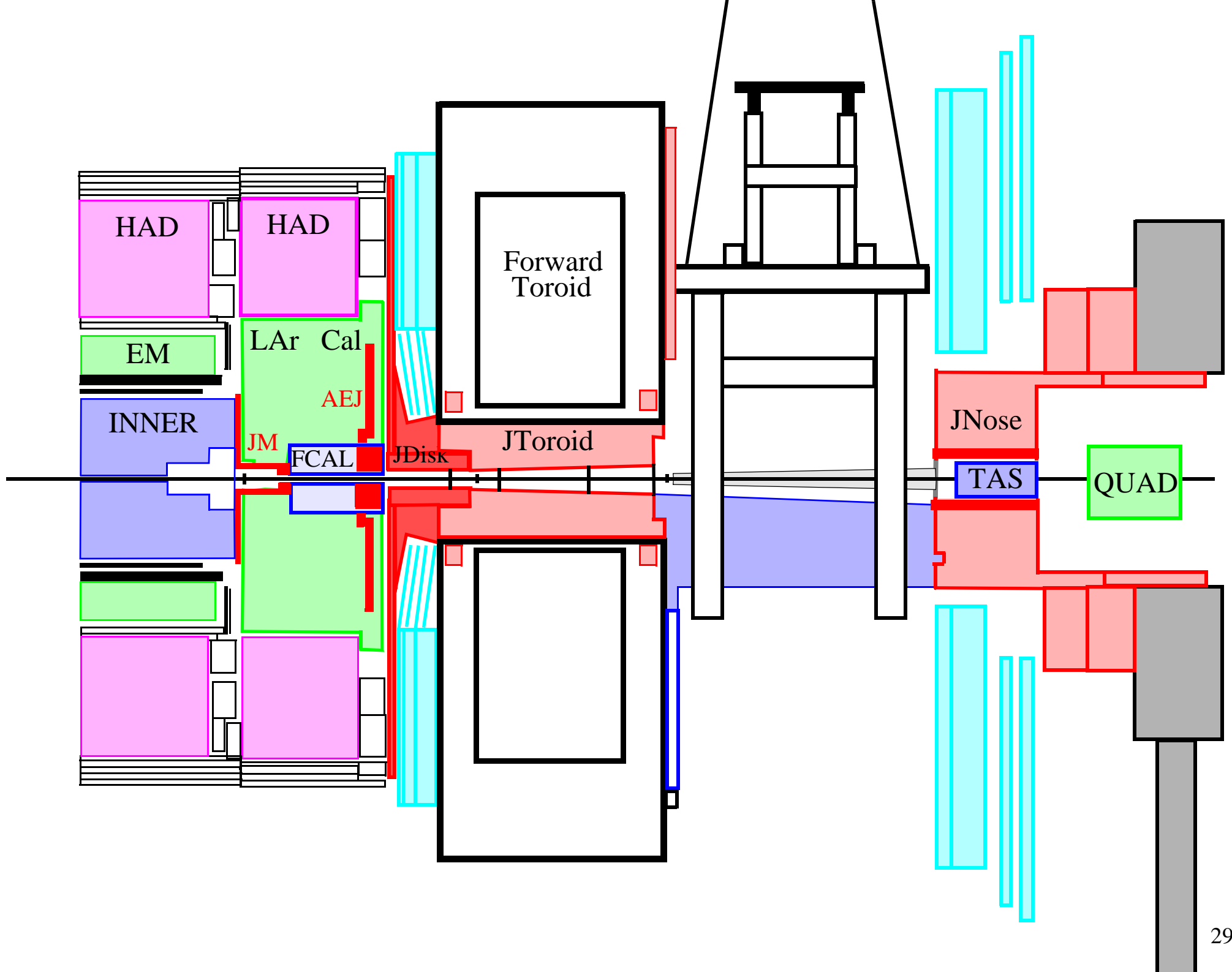

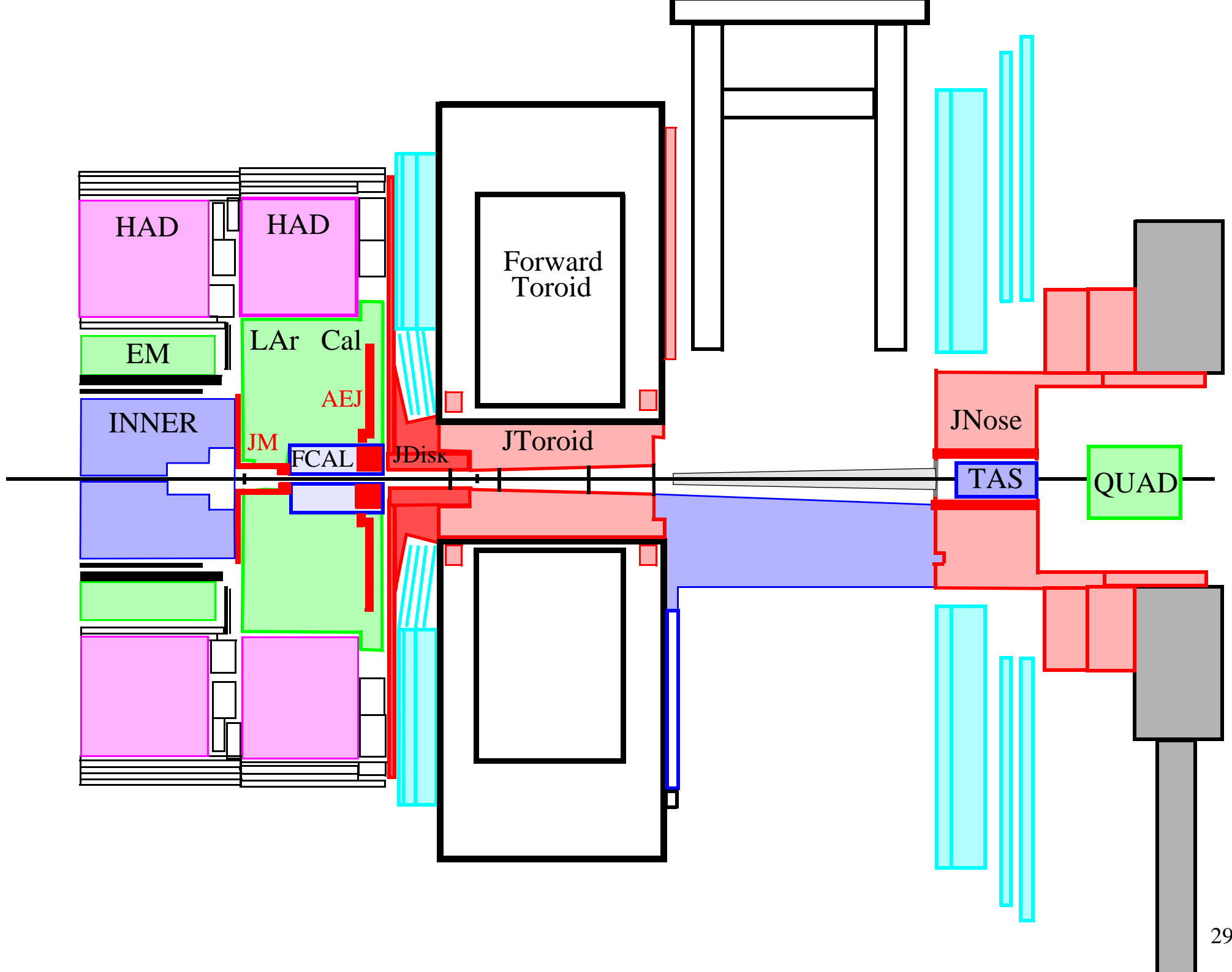

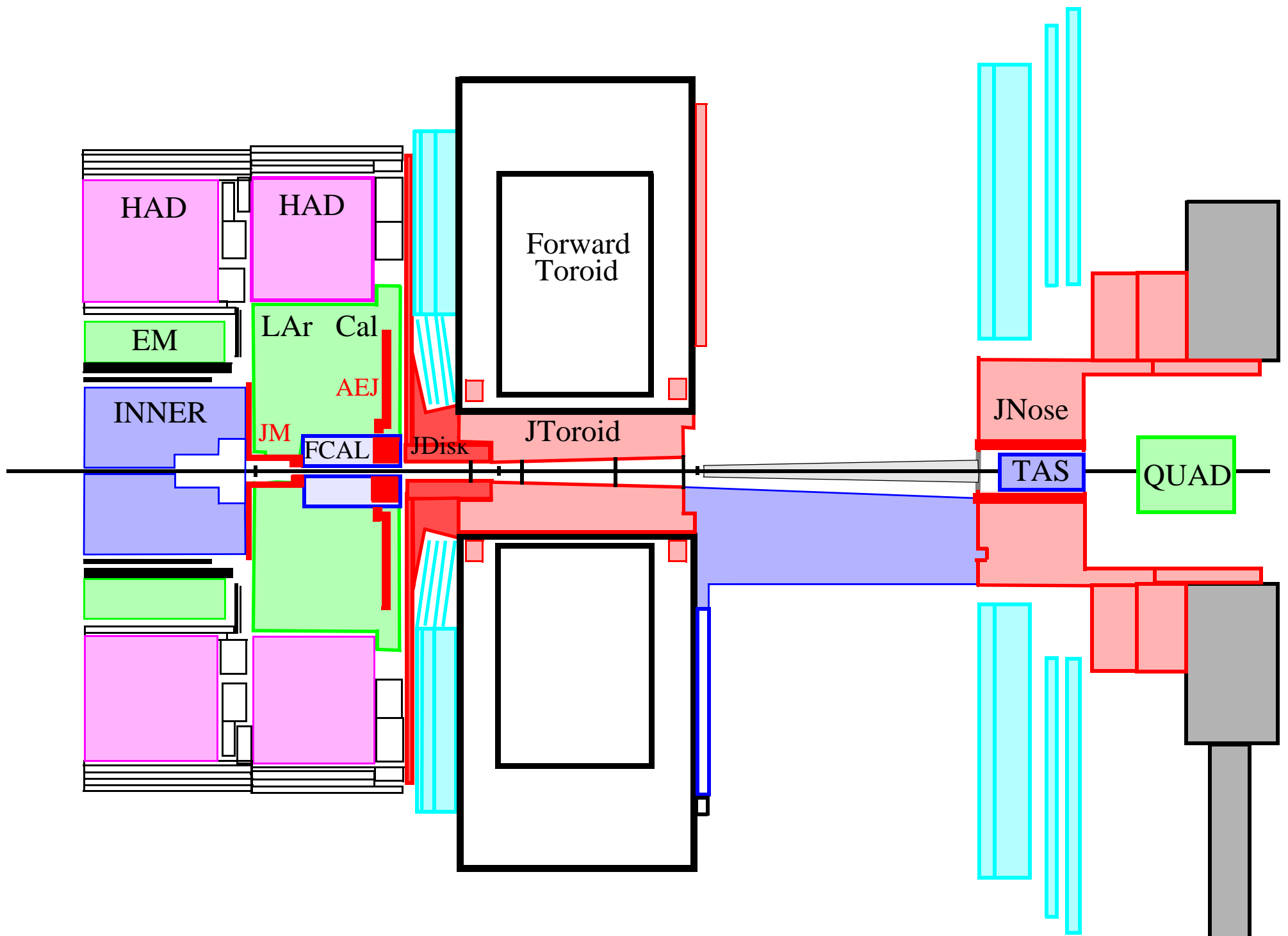

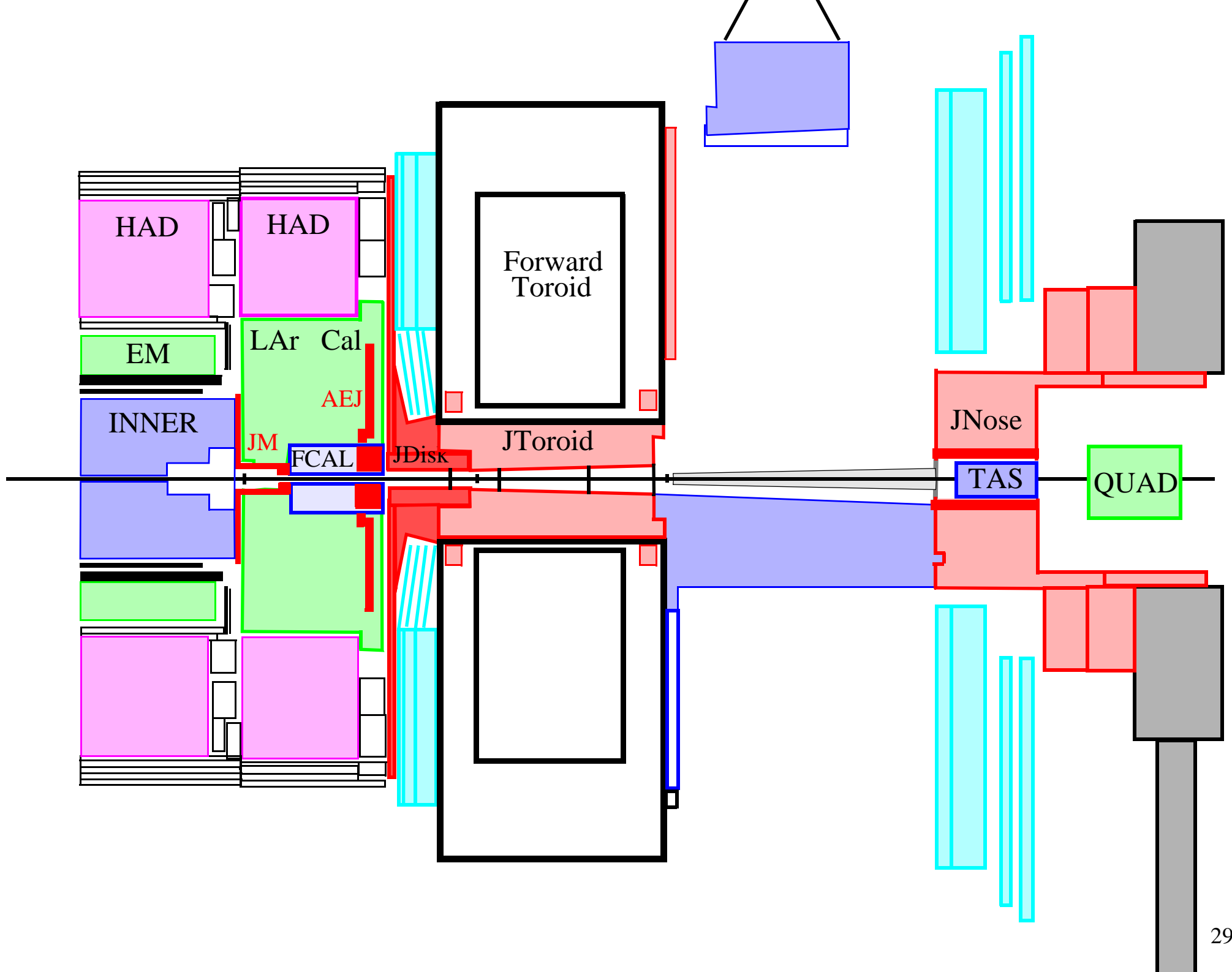

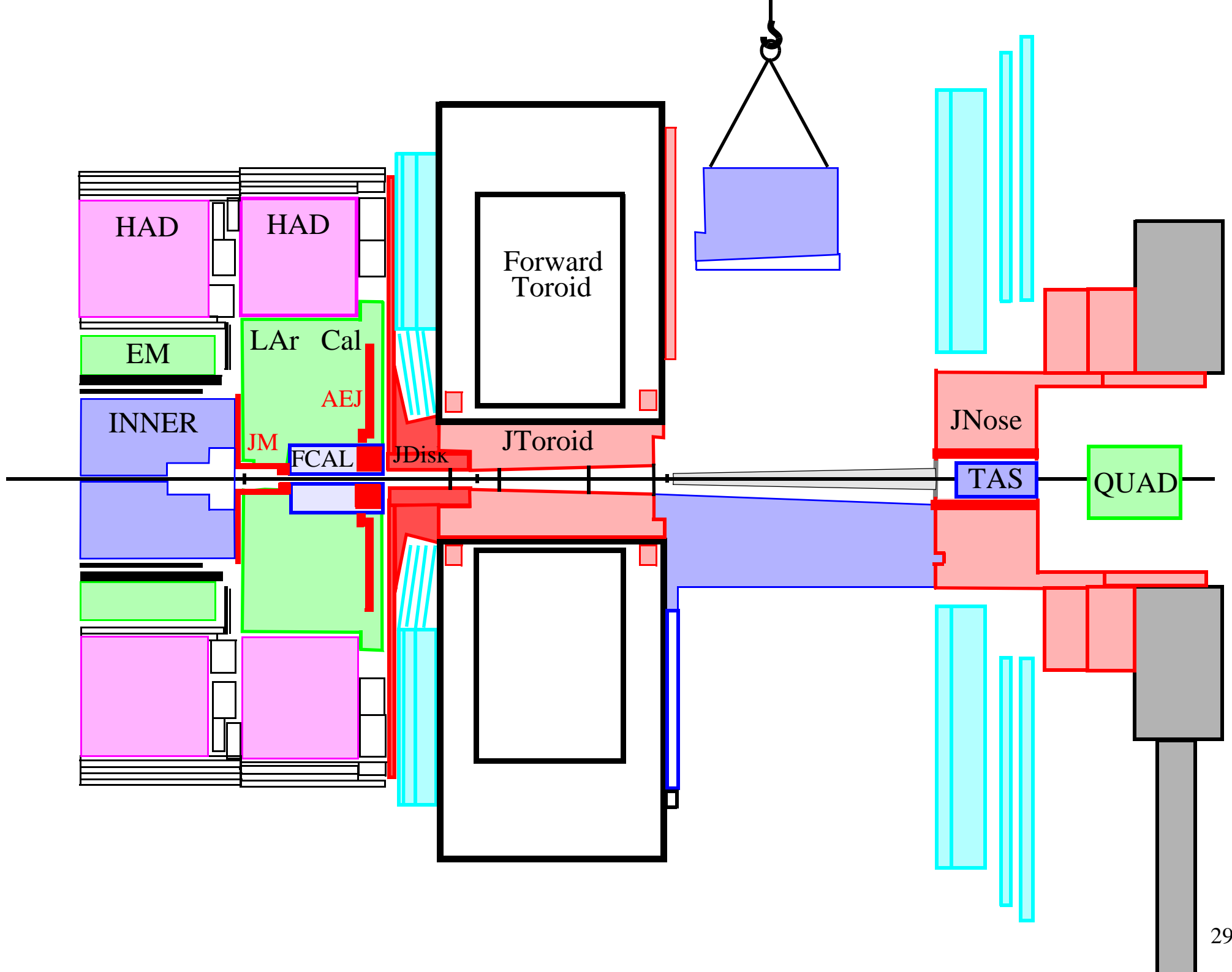

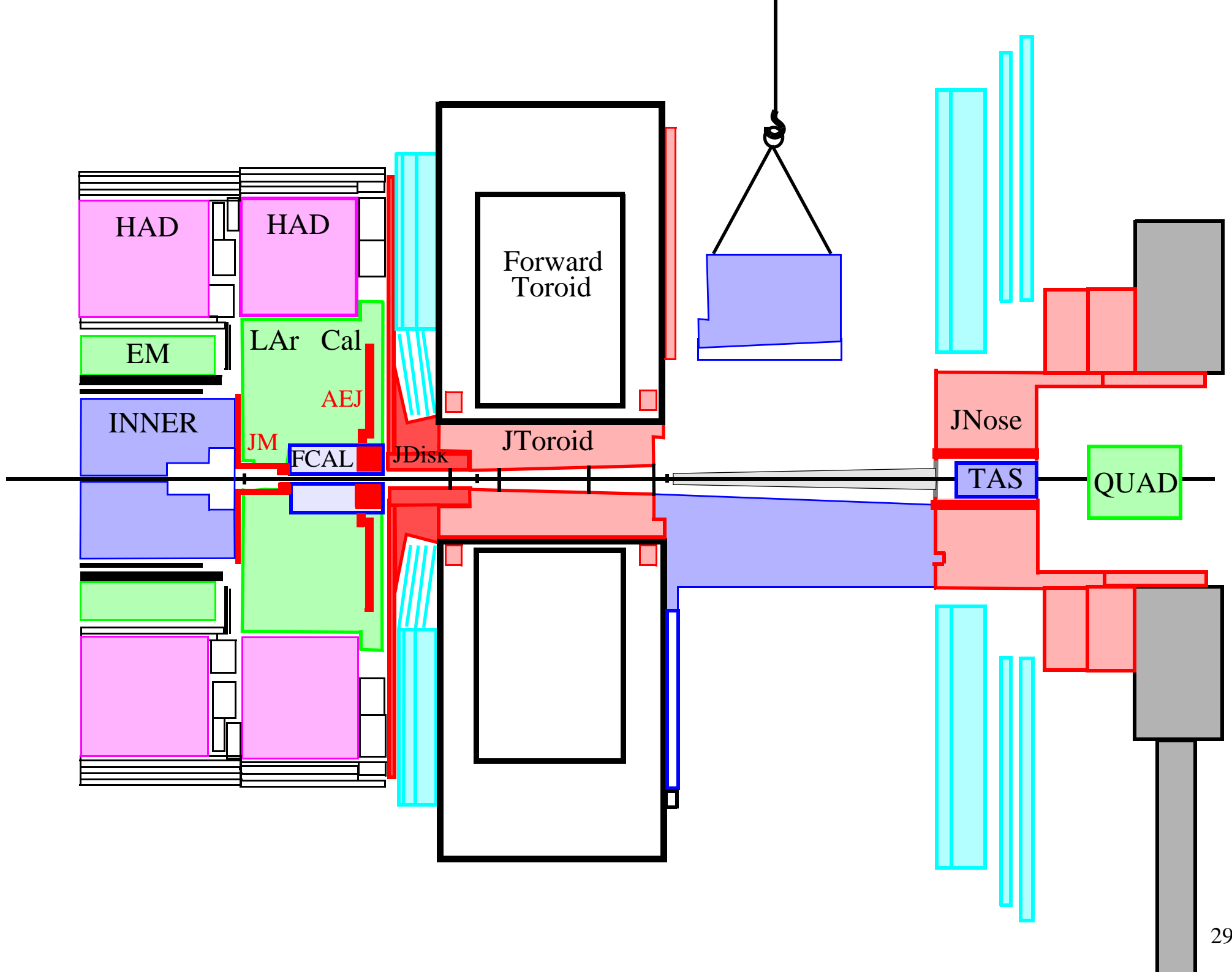

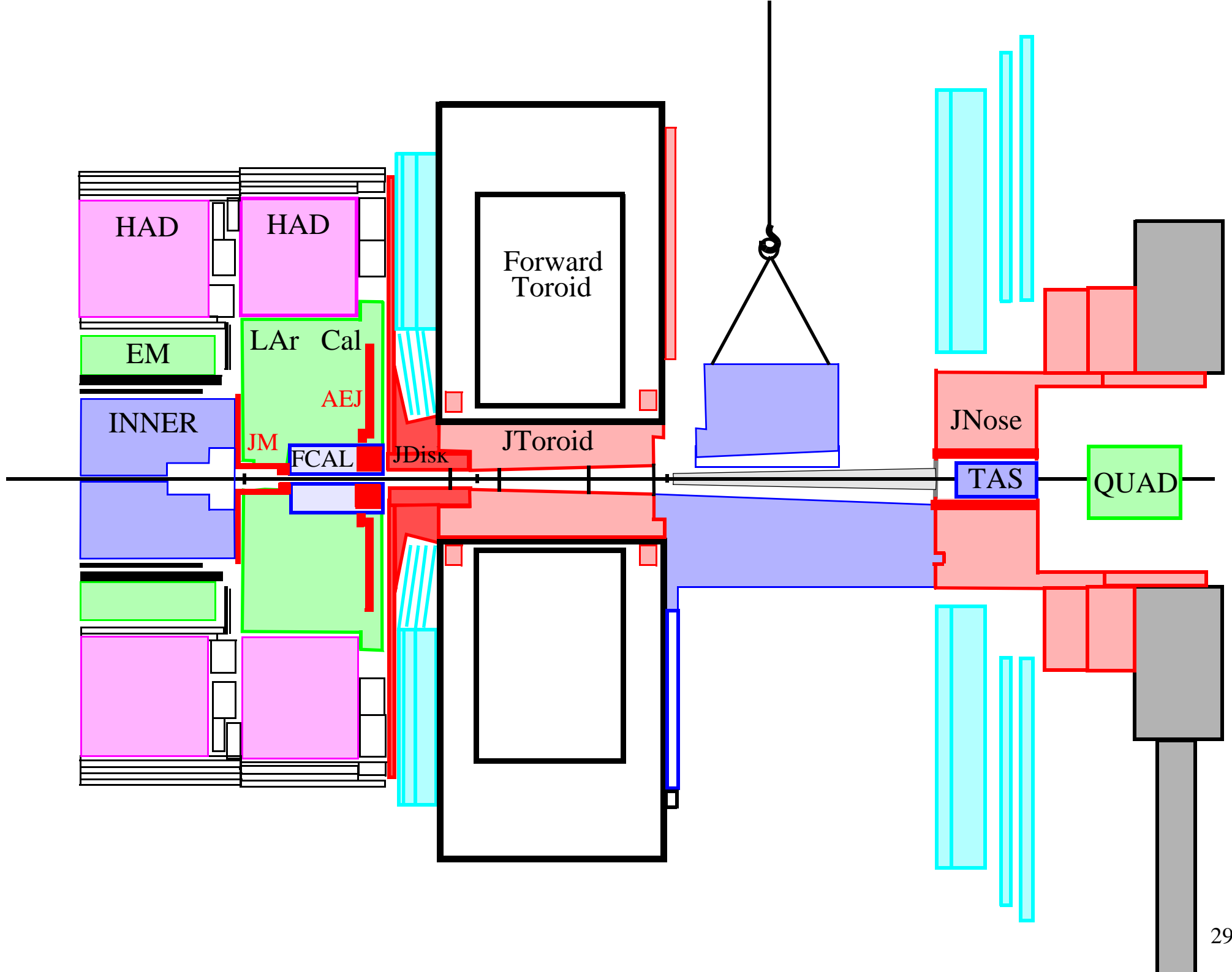

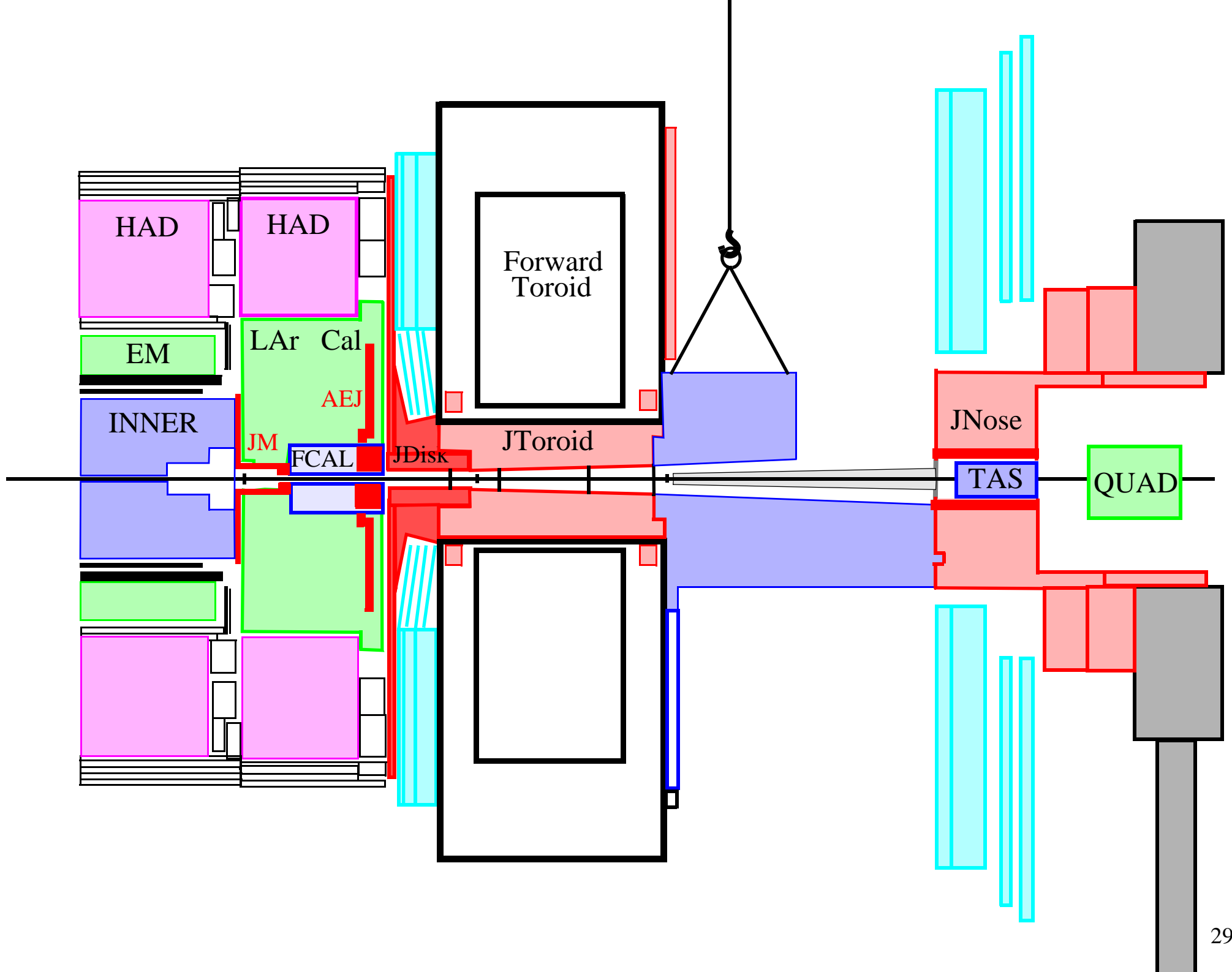

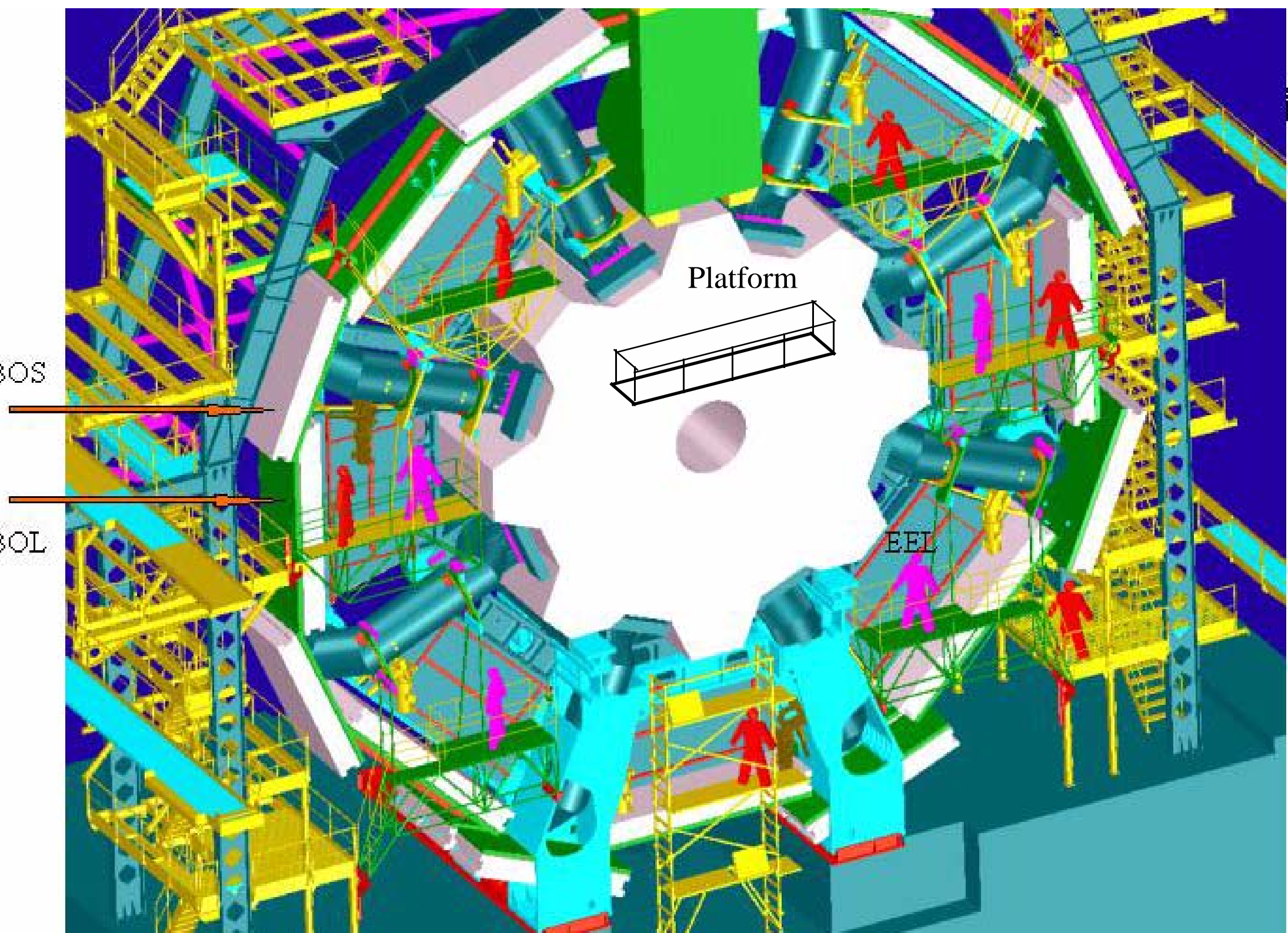

Platform

SOS

SOL

EEL

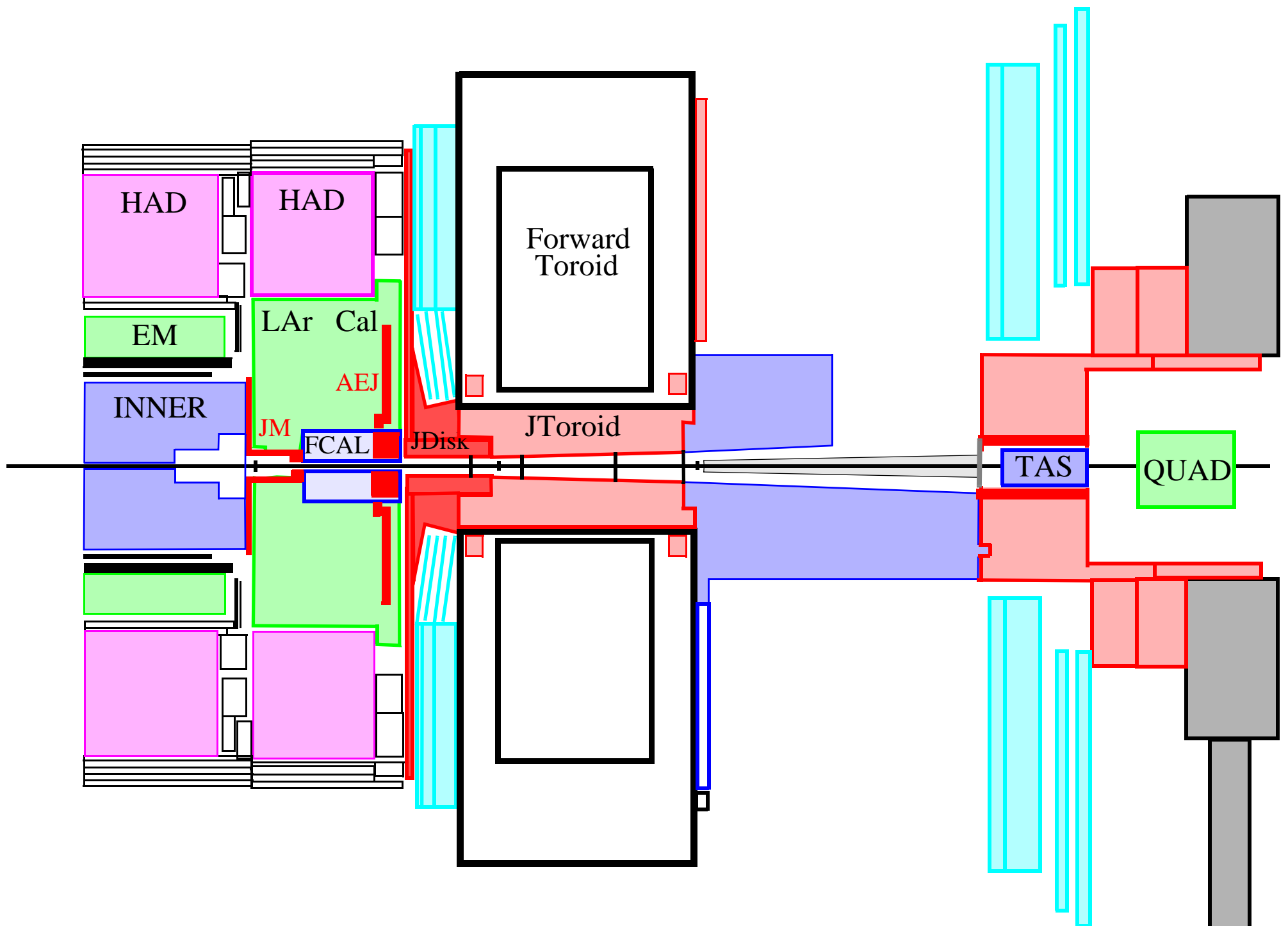

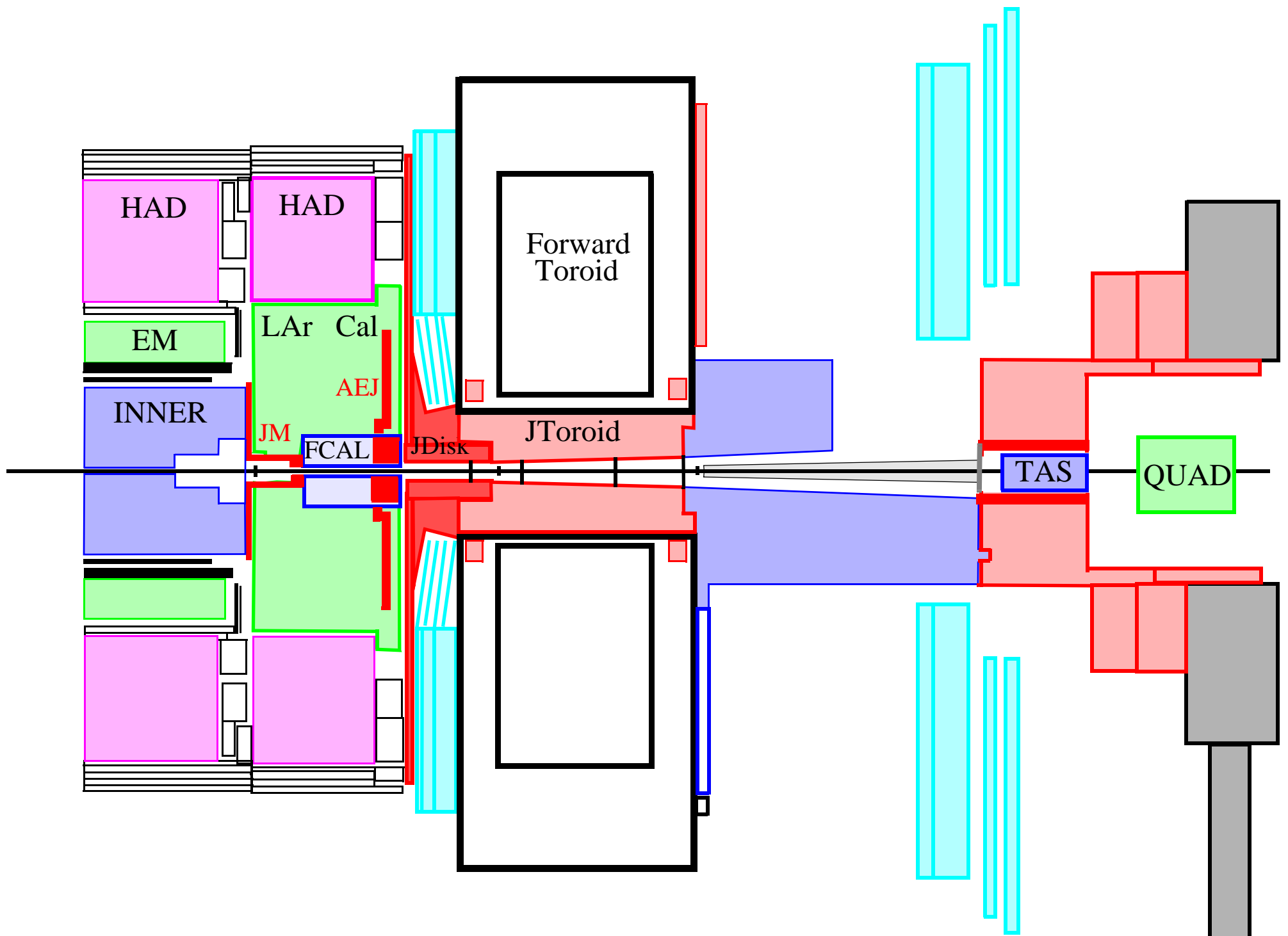

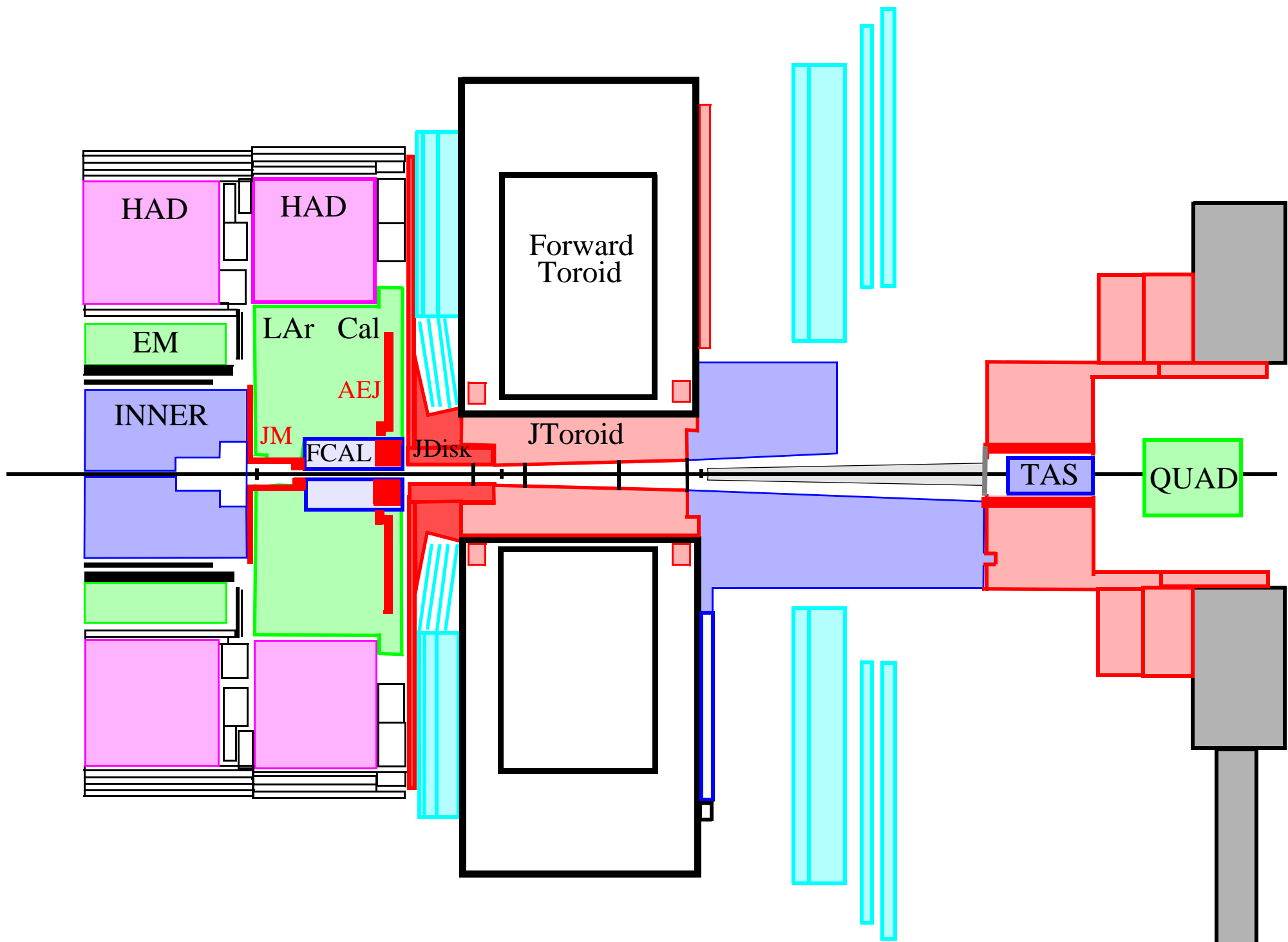

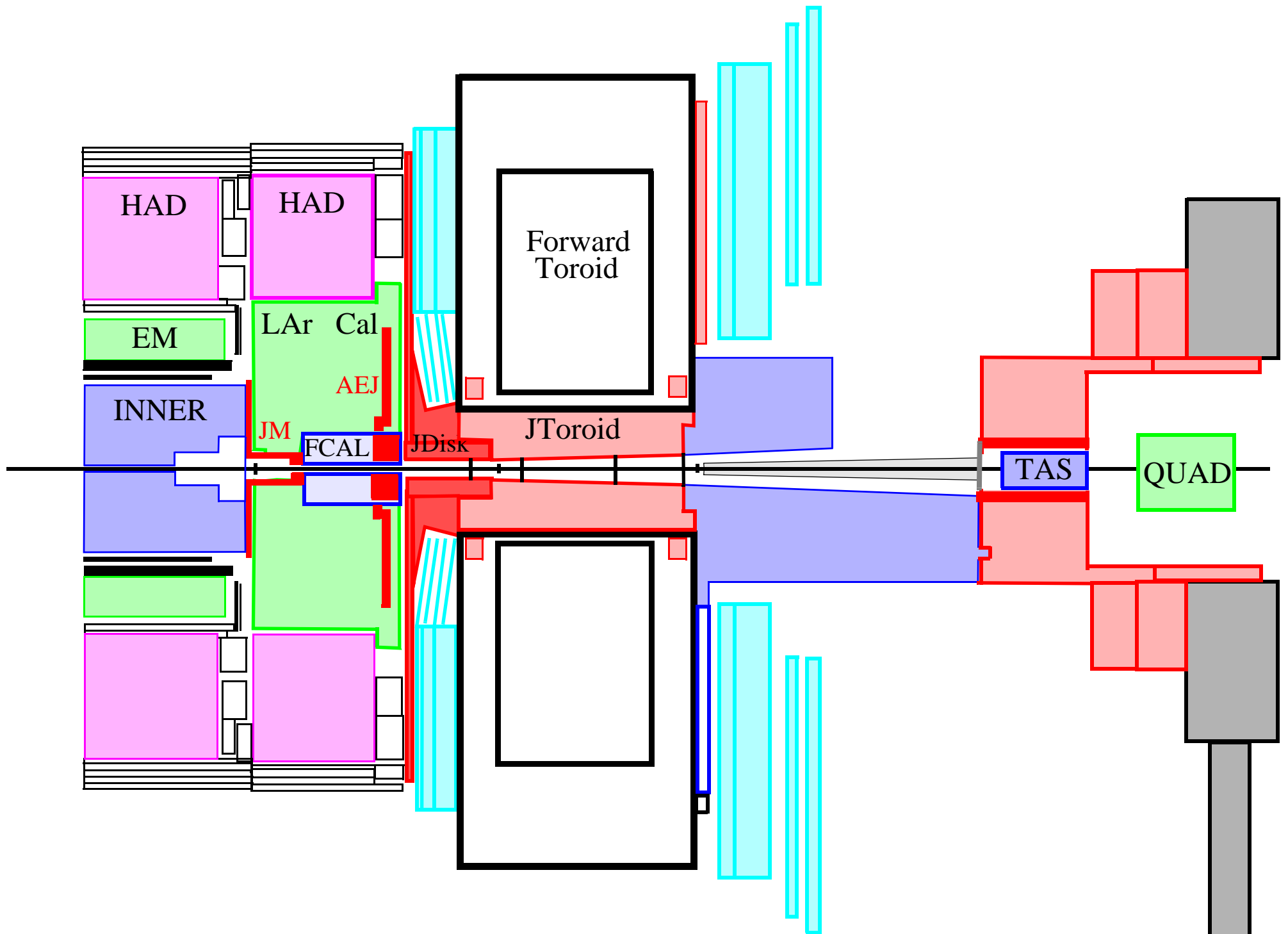

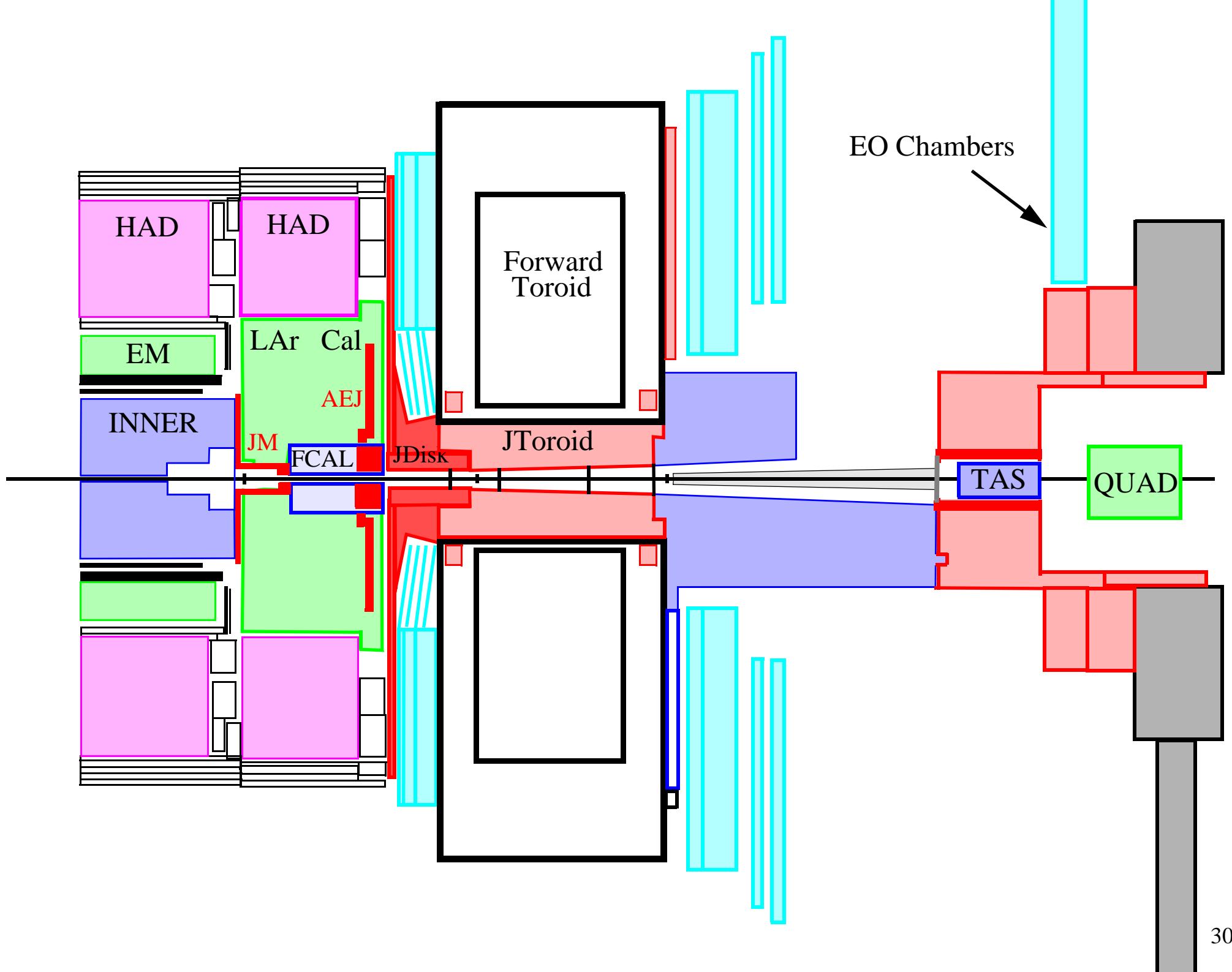

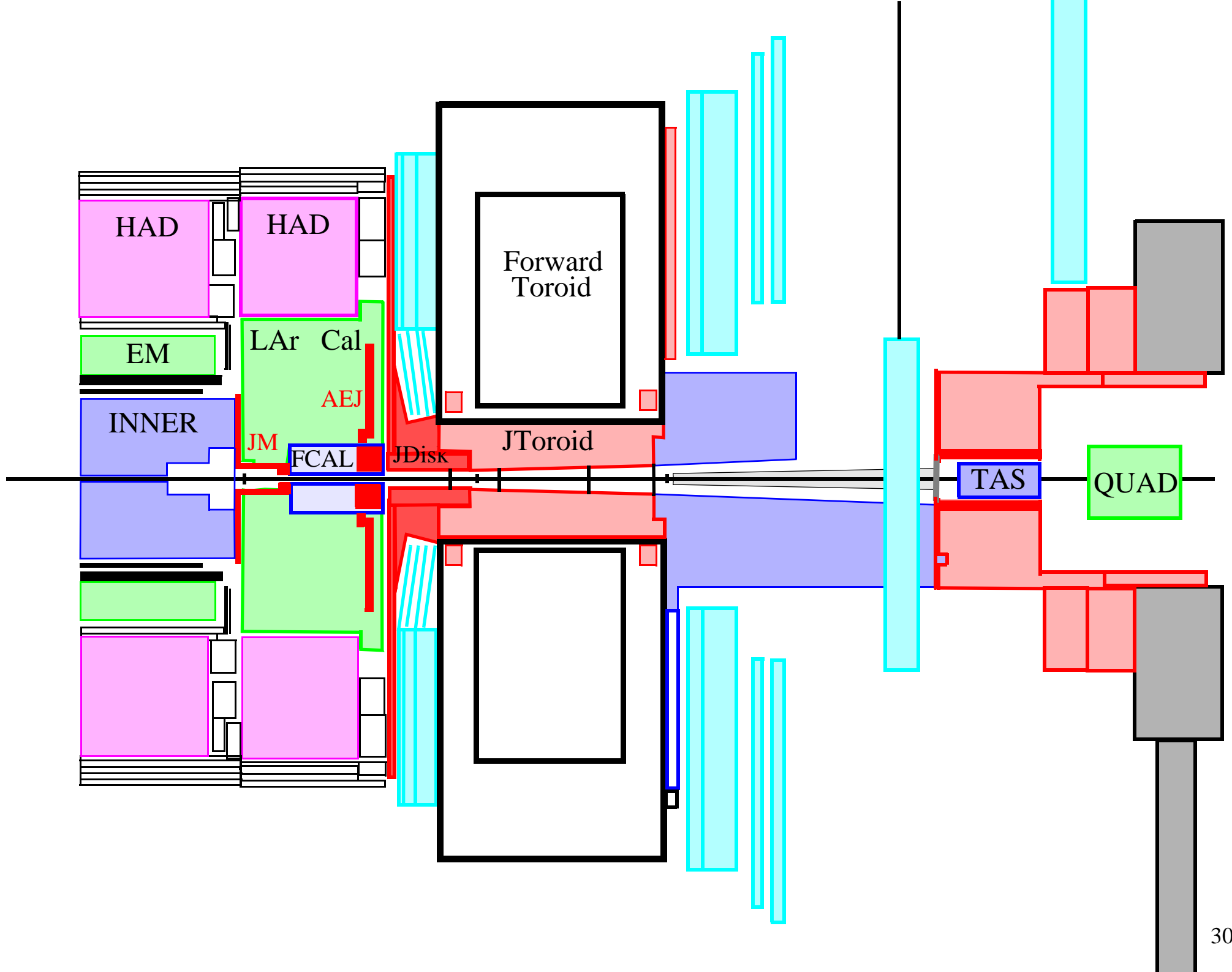

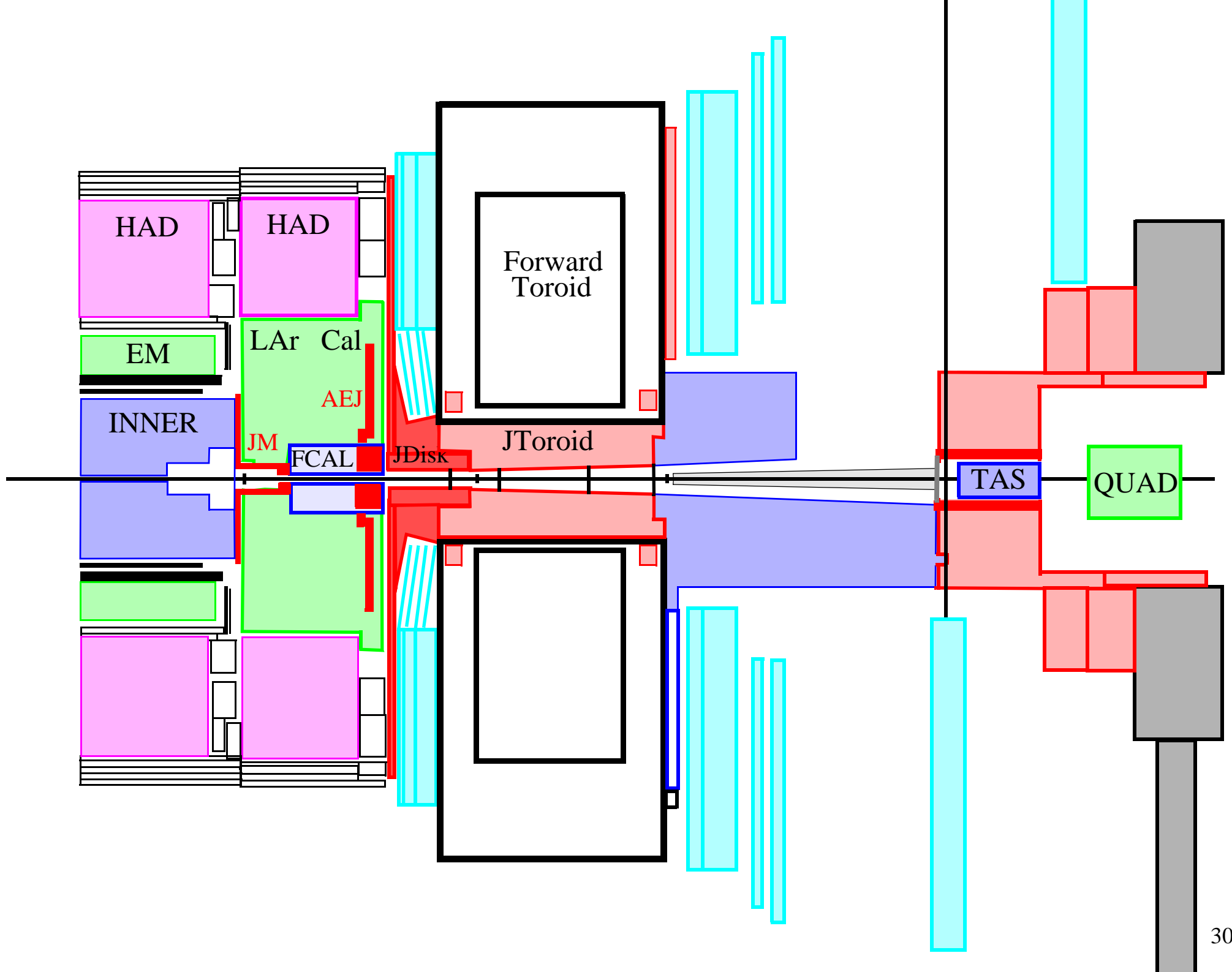

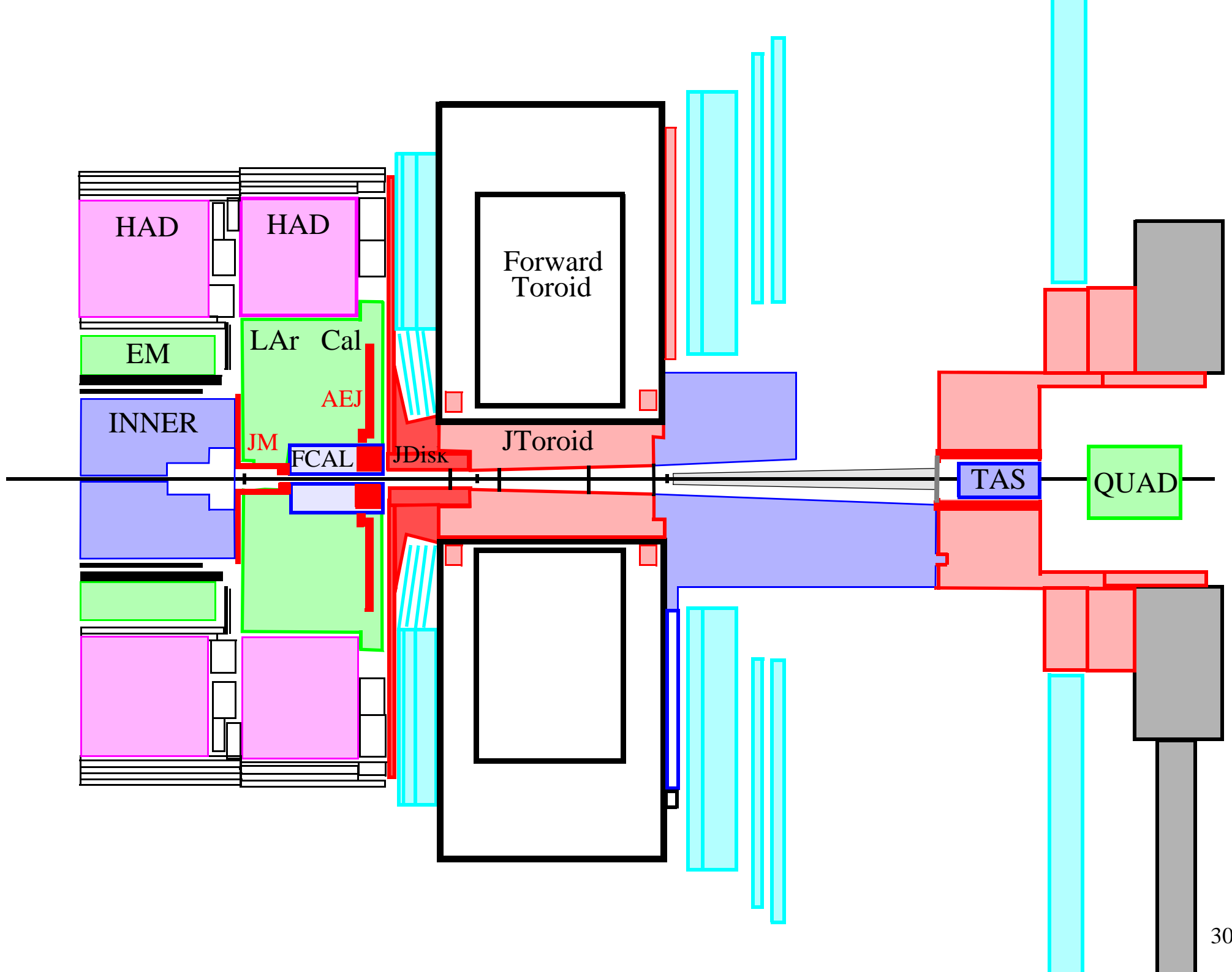

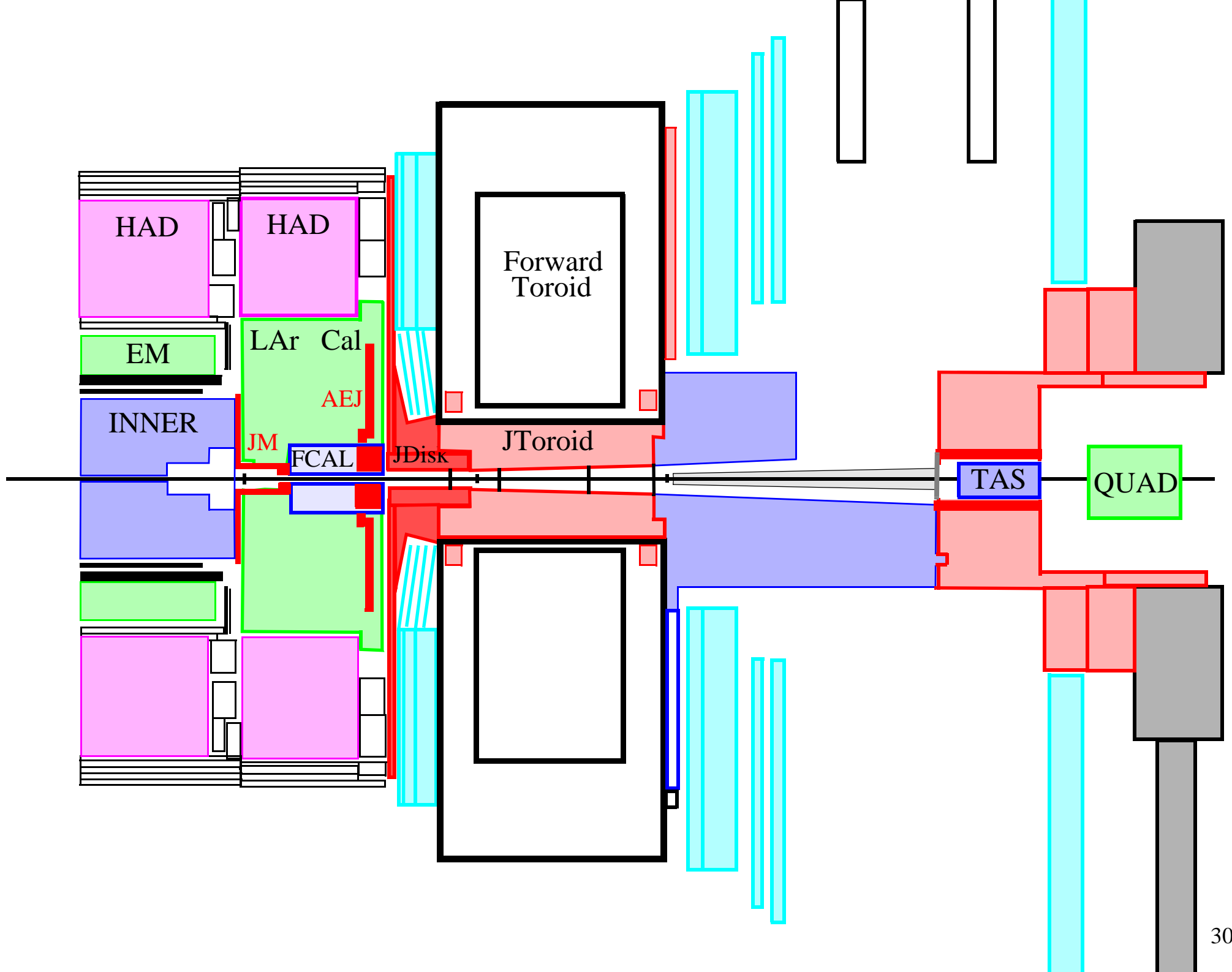

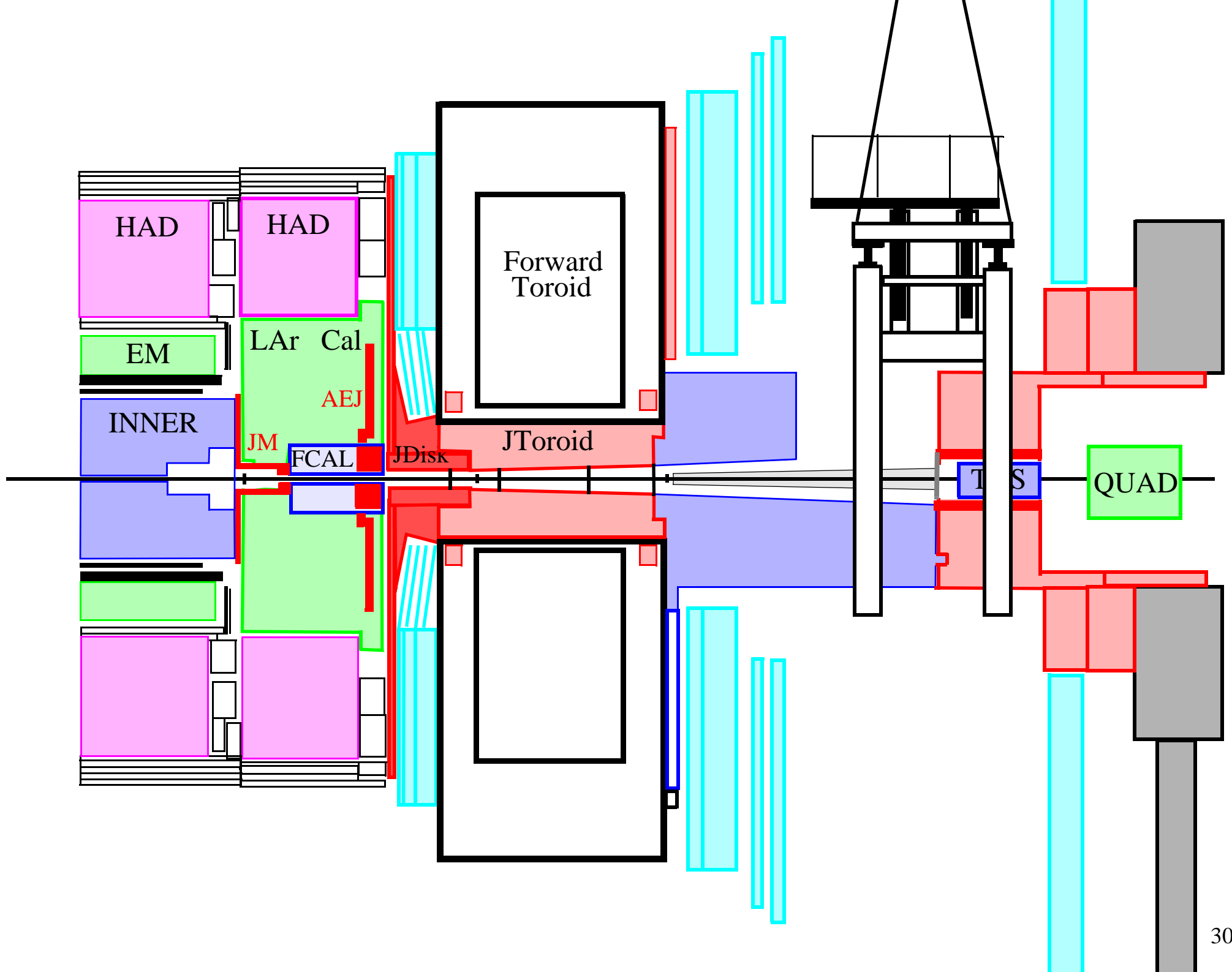

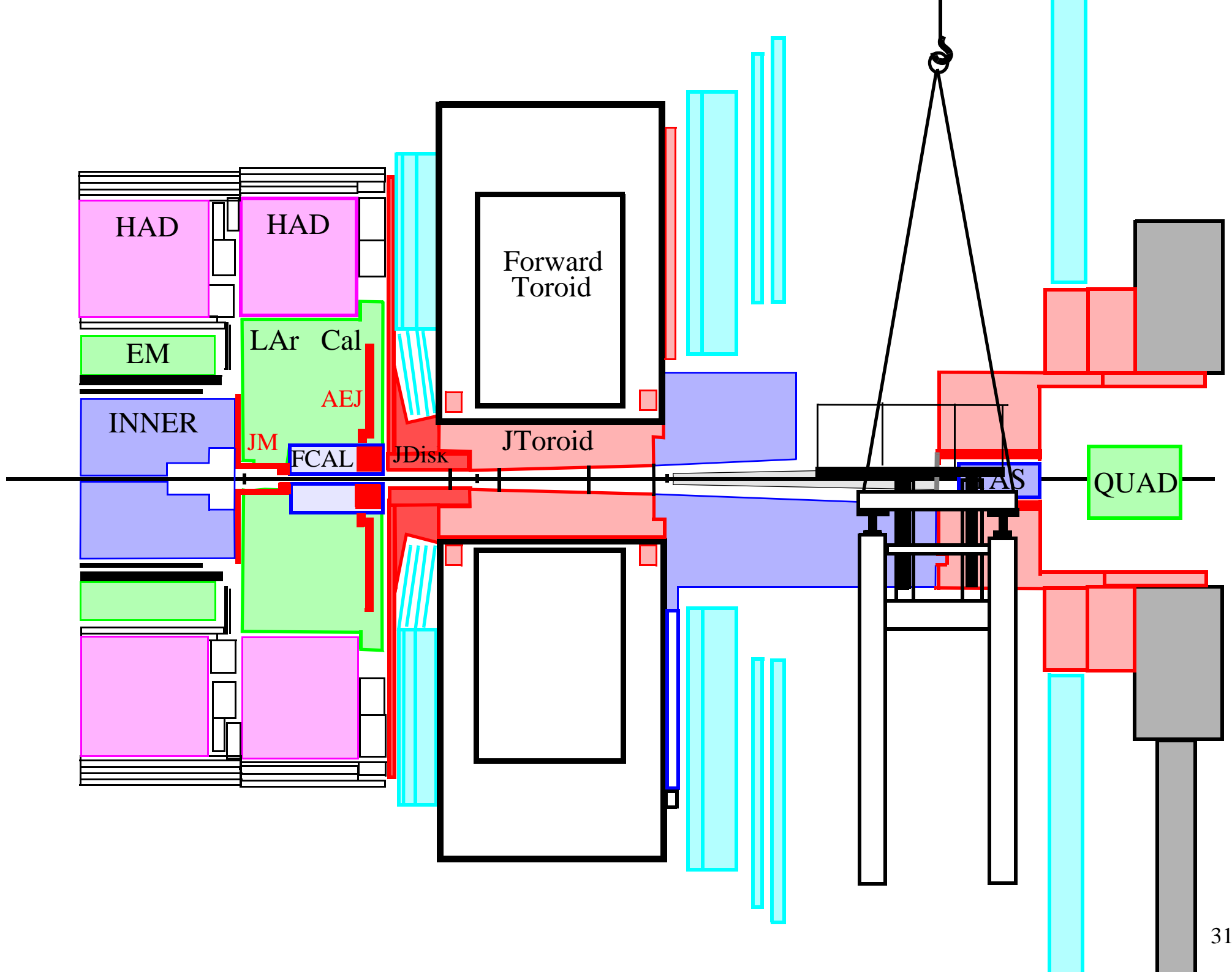

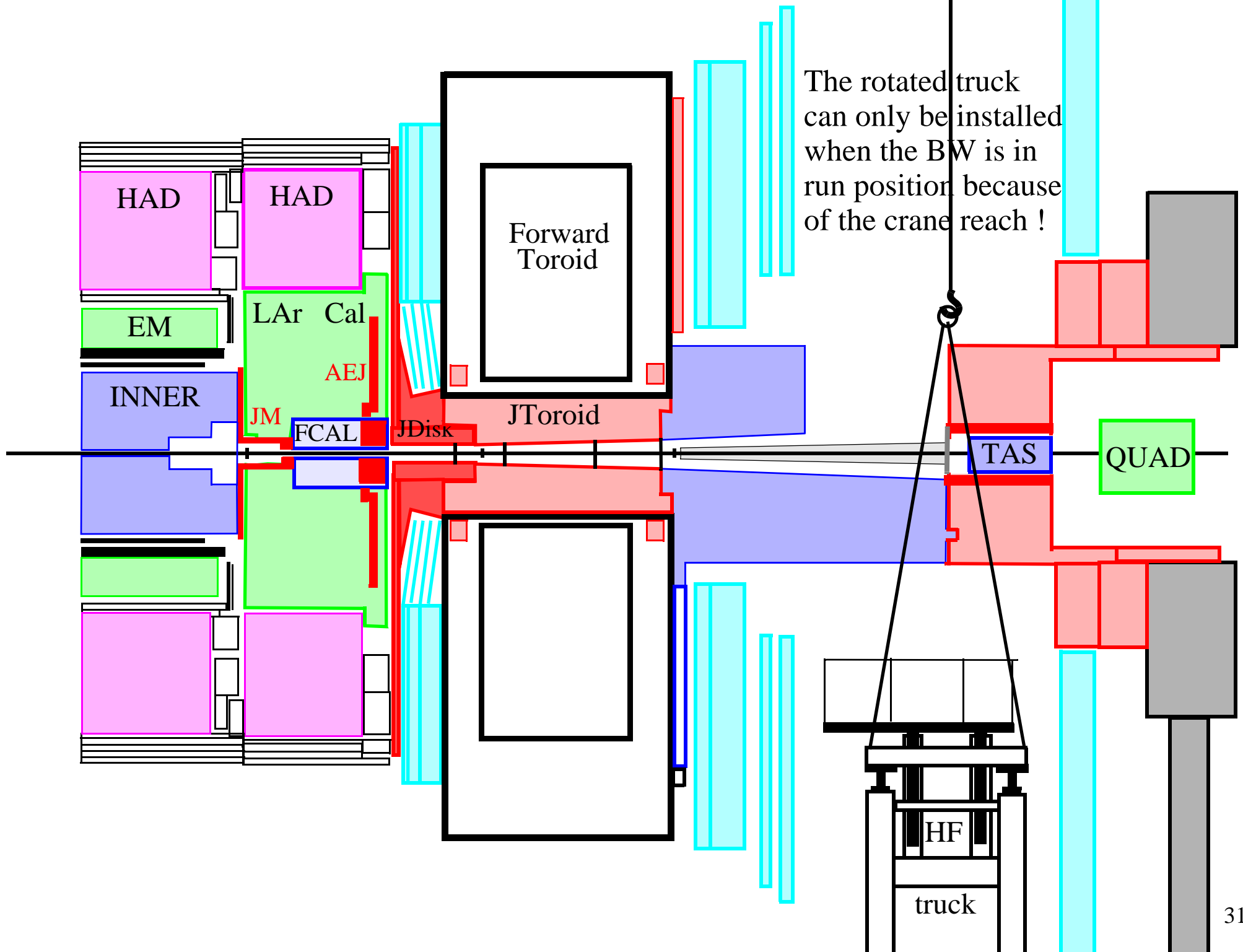

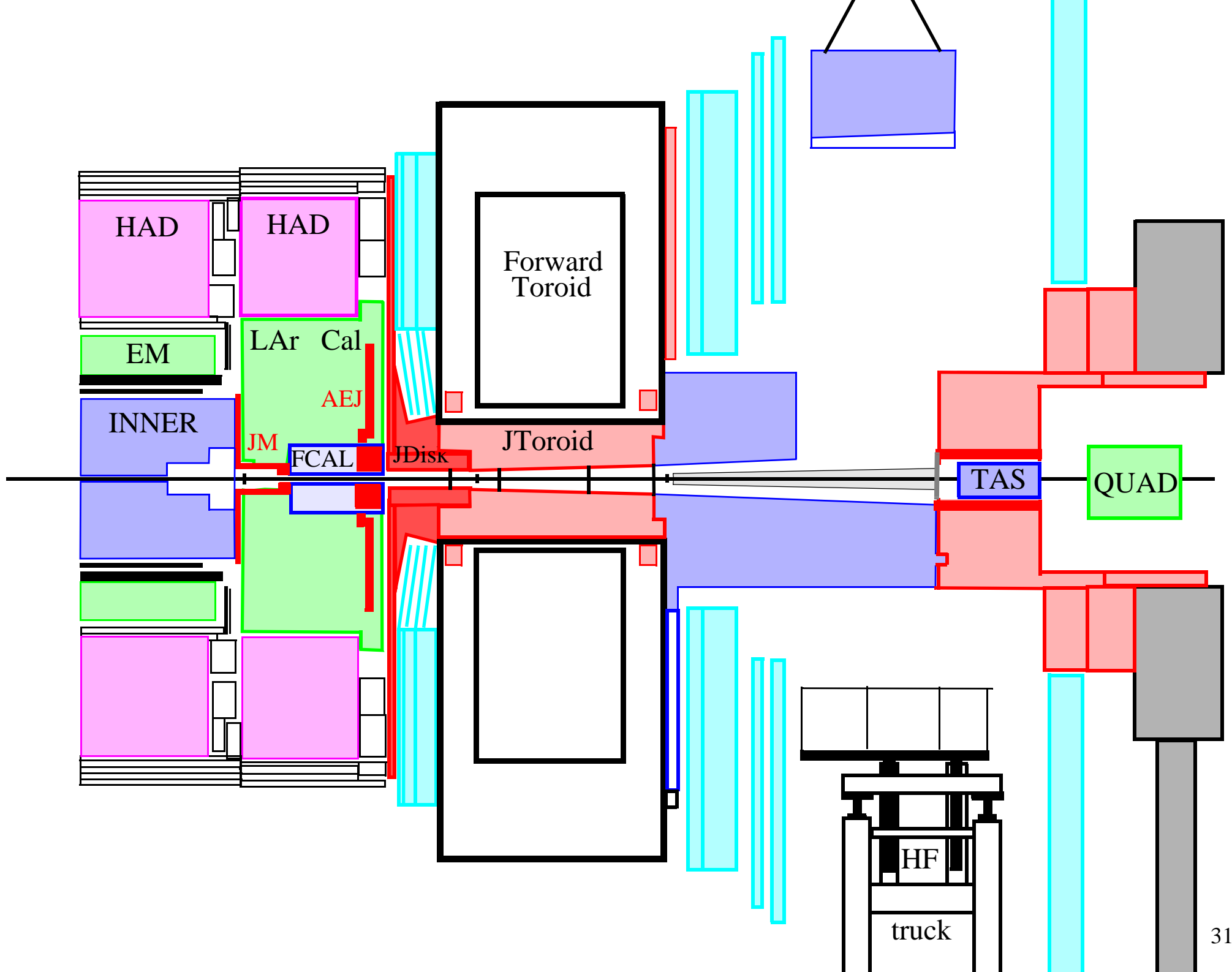

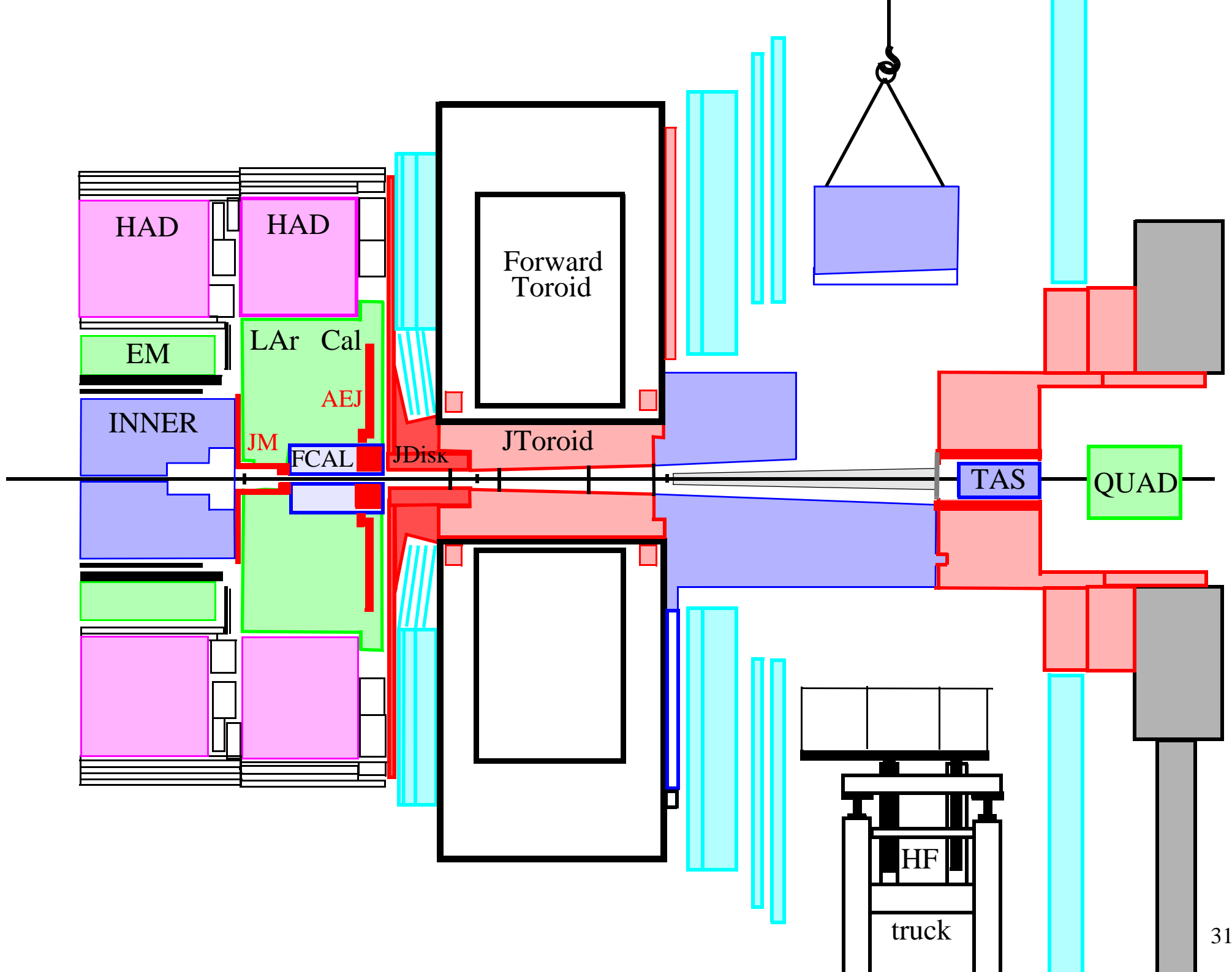

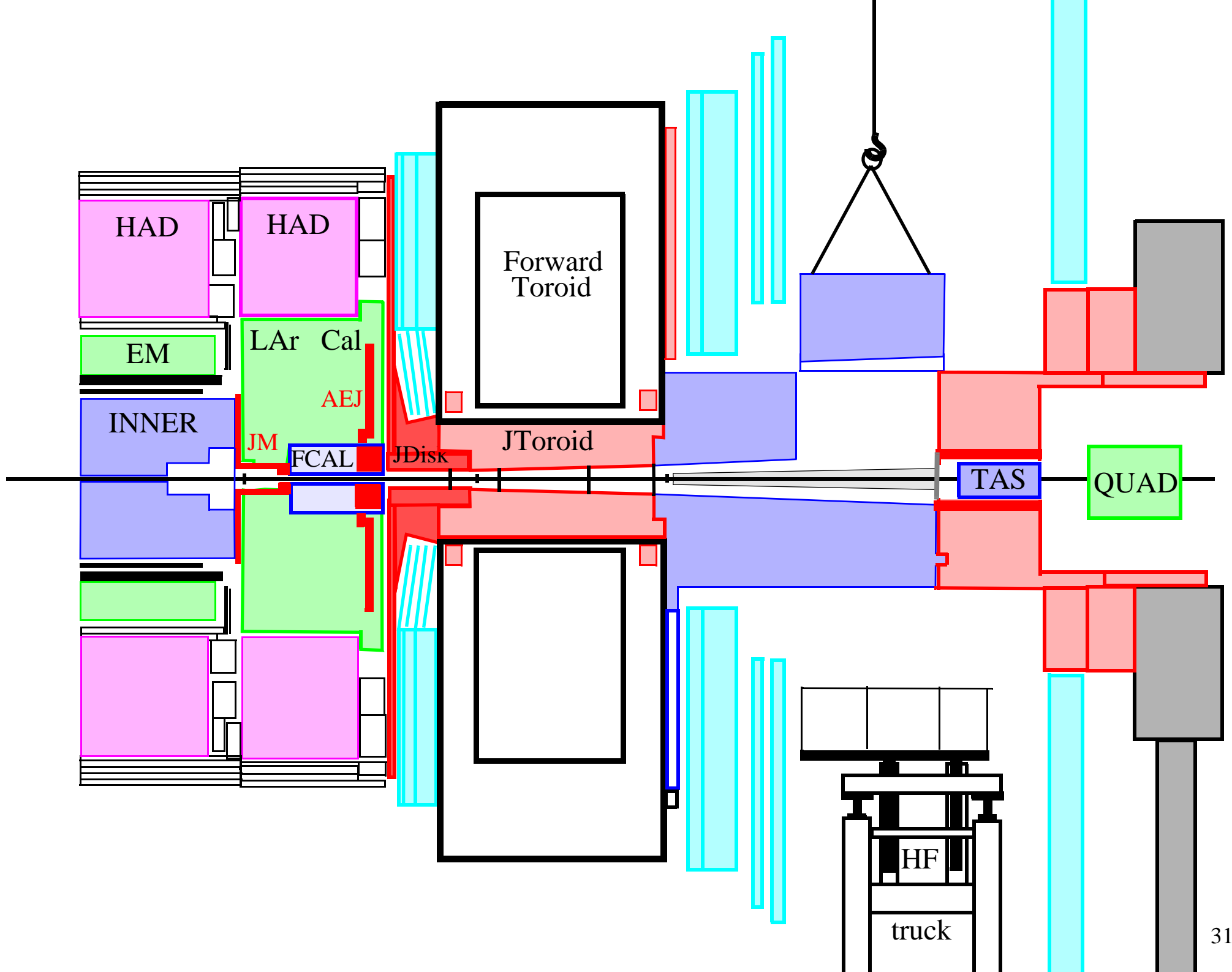

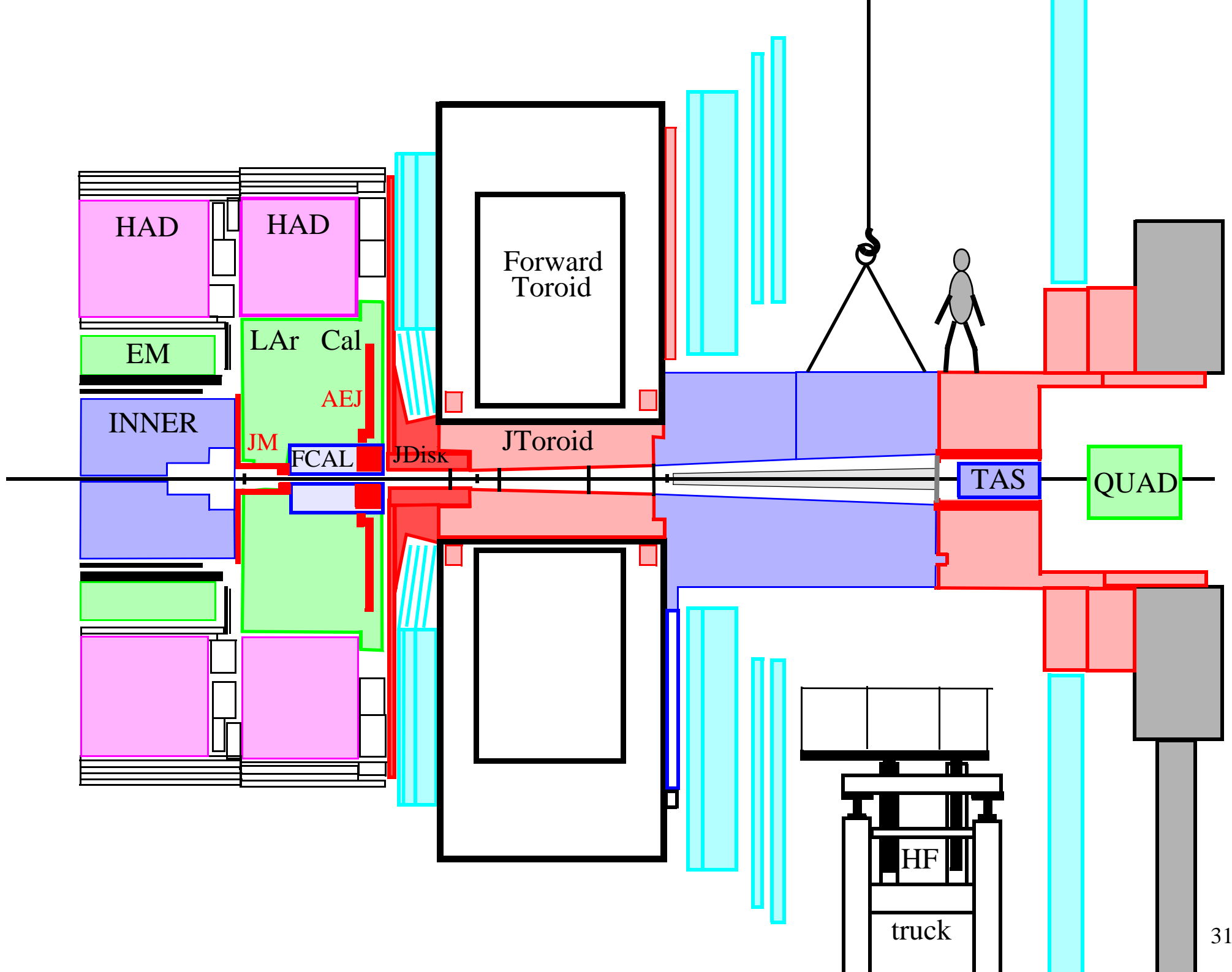

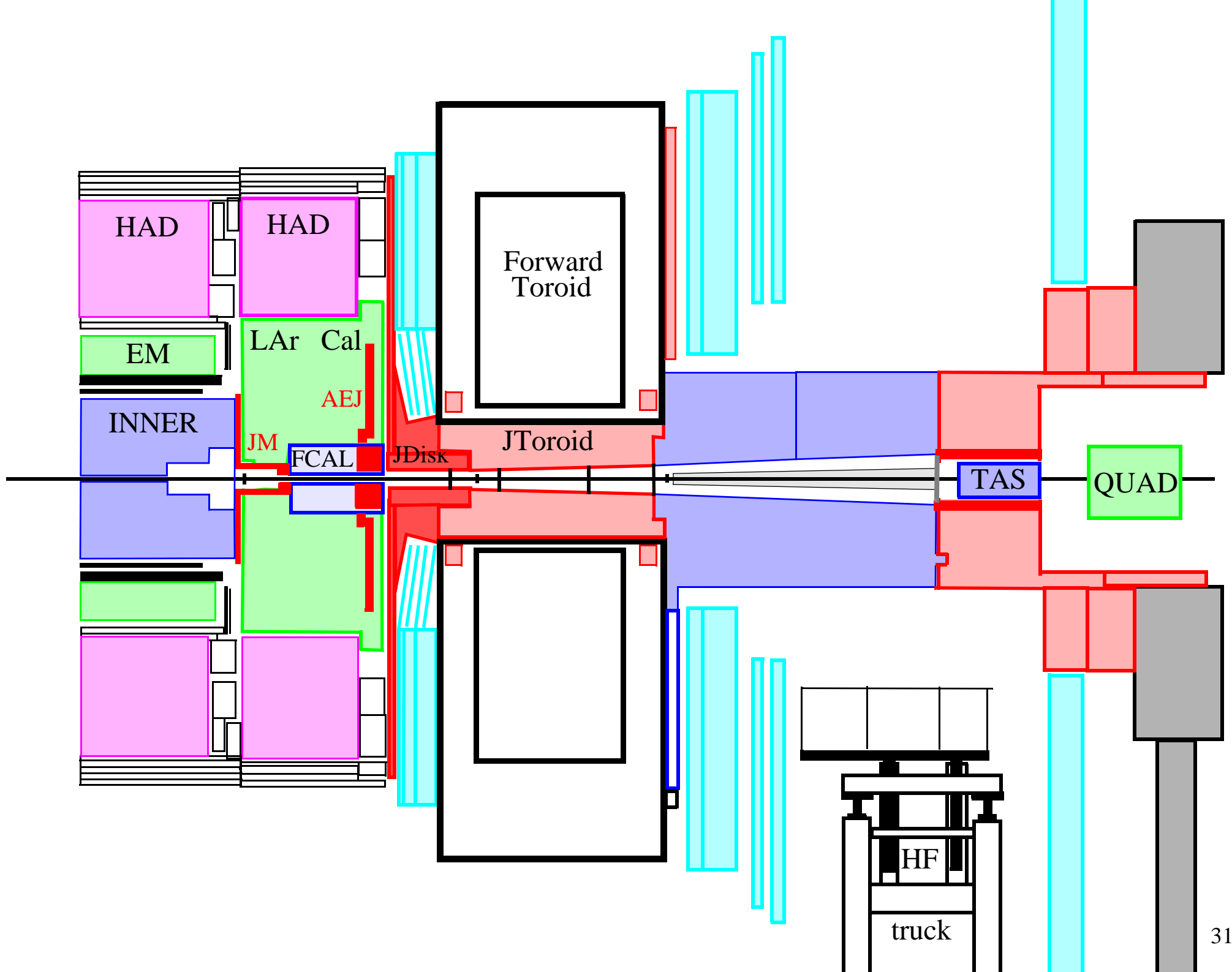

August 2007

