

May 2006

Side C

The scenario starts with the installation of the Big Wheel TGC1 in May 2006 !

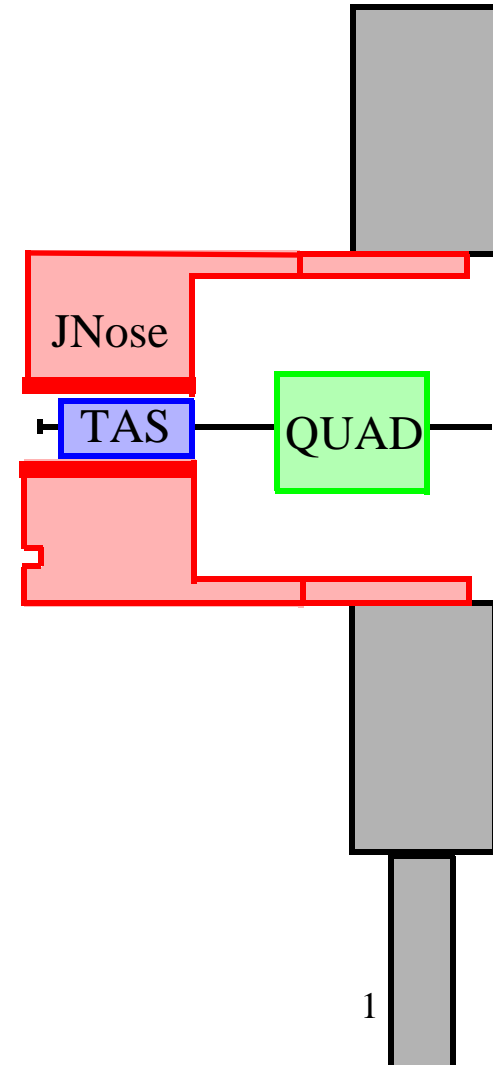

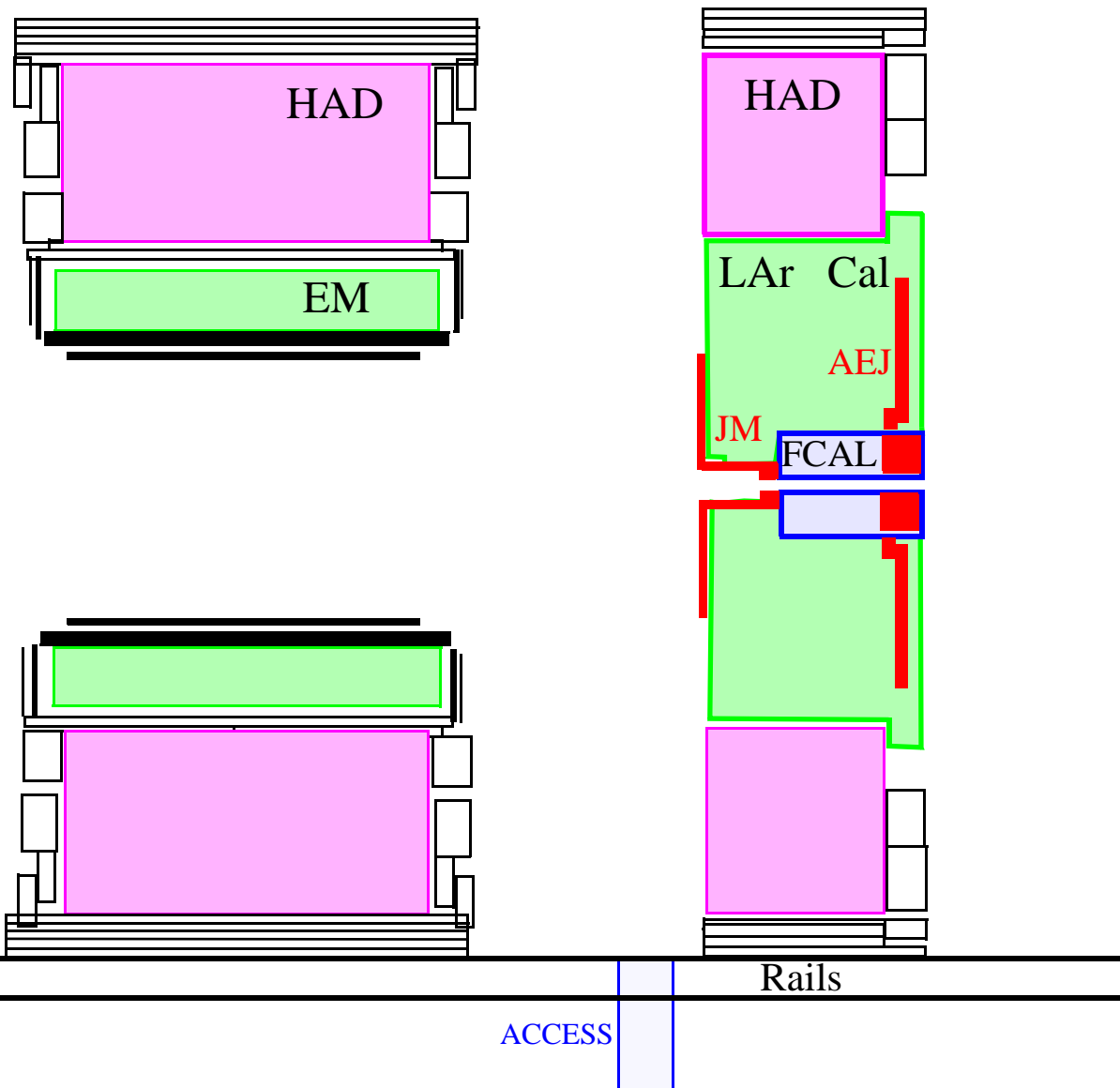
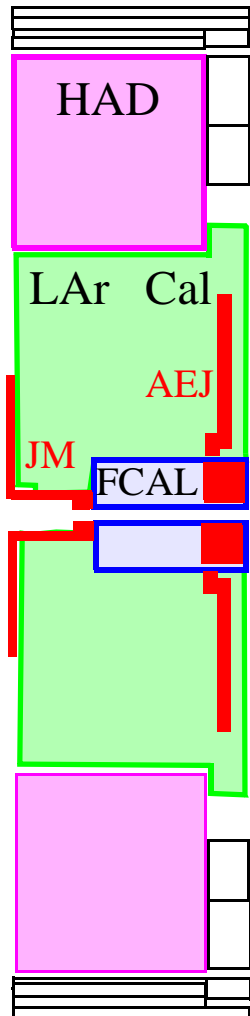
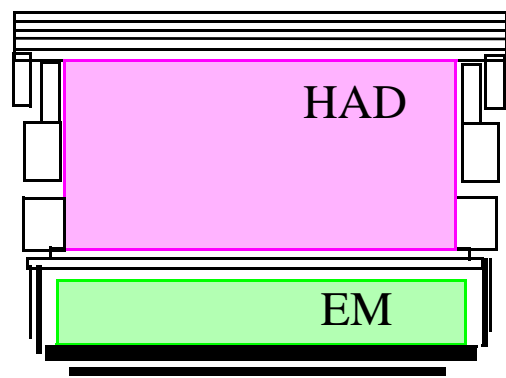

TGC 1

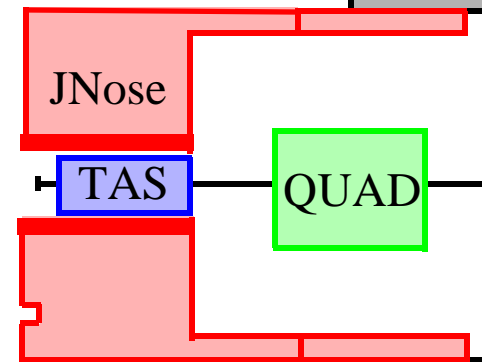

ACCESS

Rails

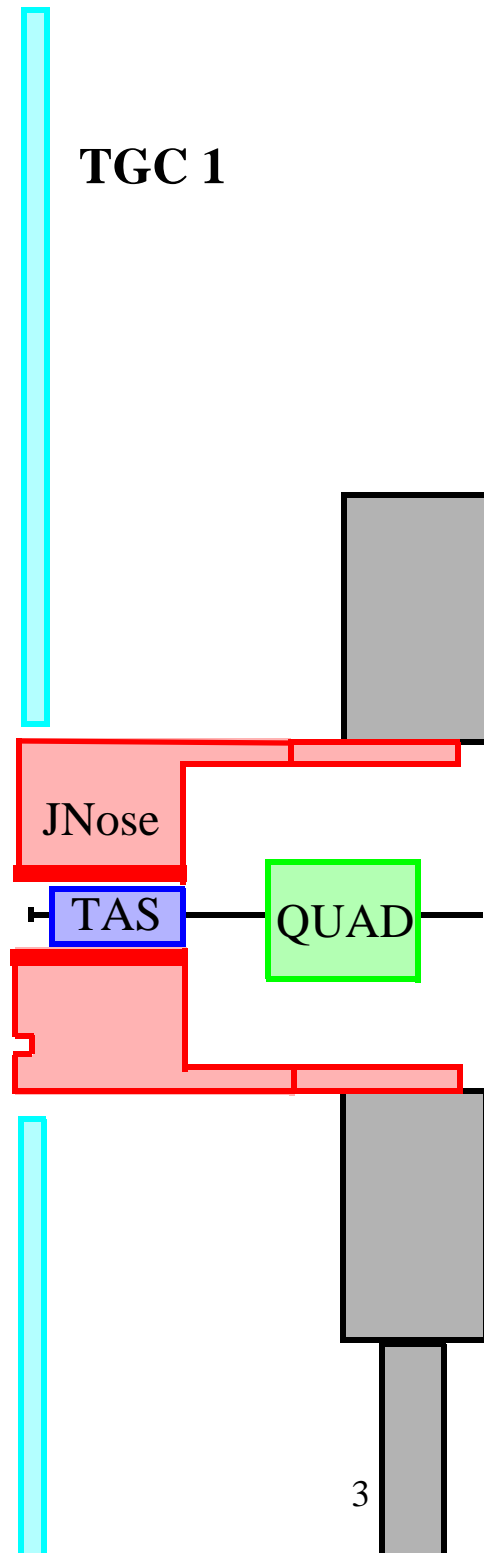
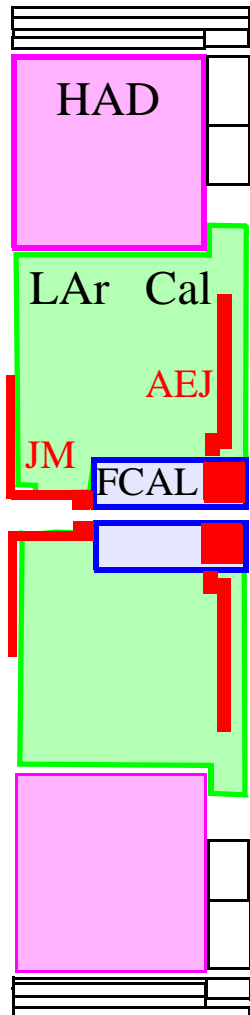
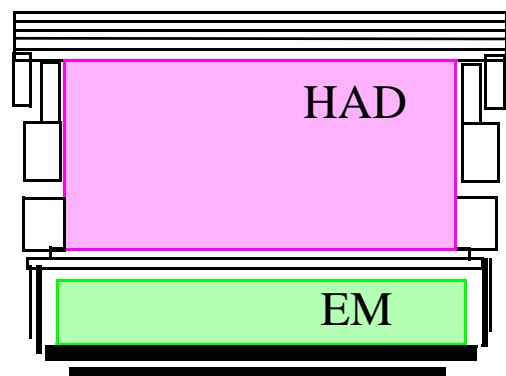

ACCESS

Rails

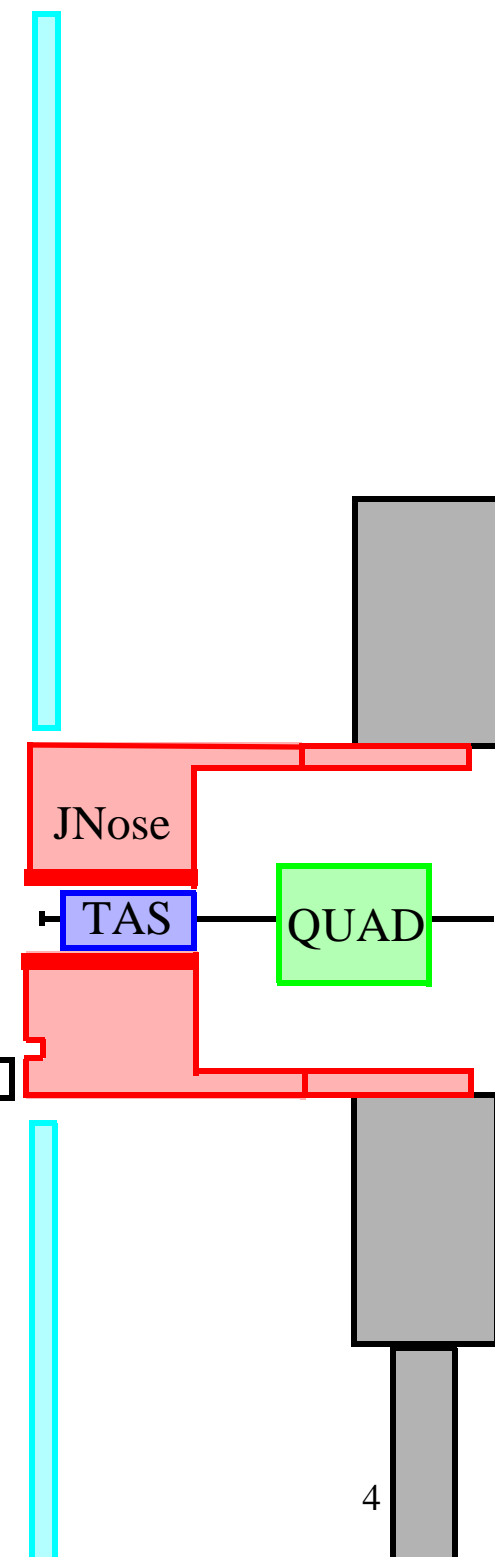
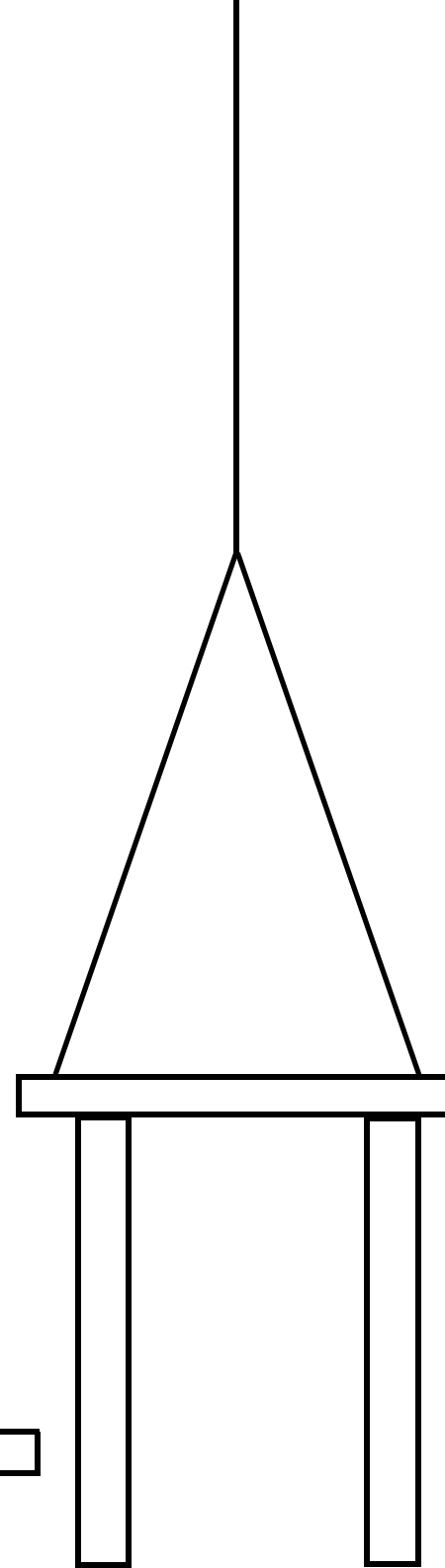
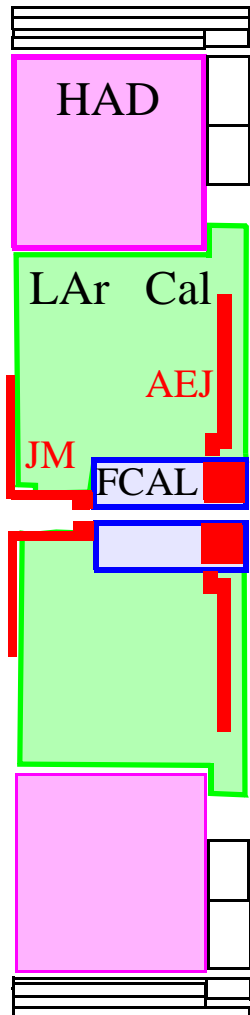
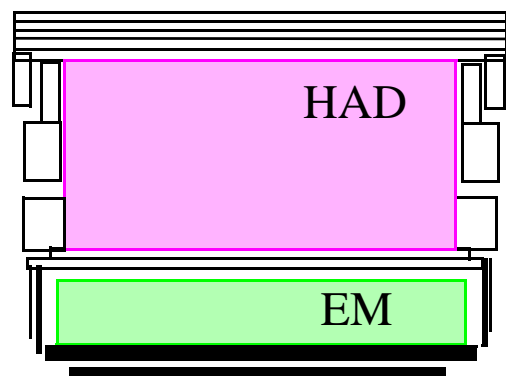

ACCESS

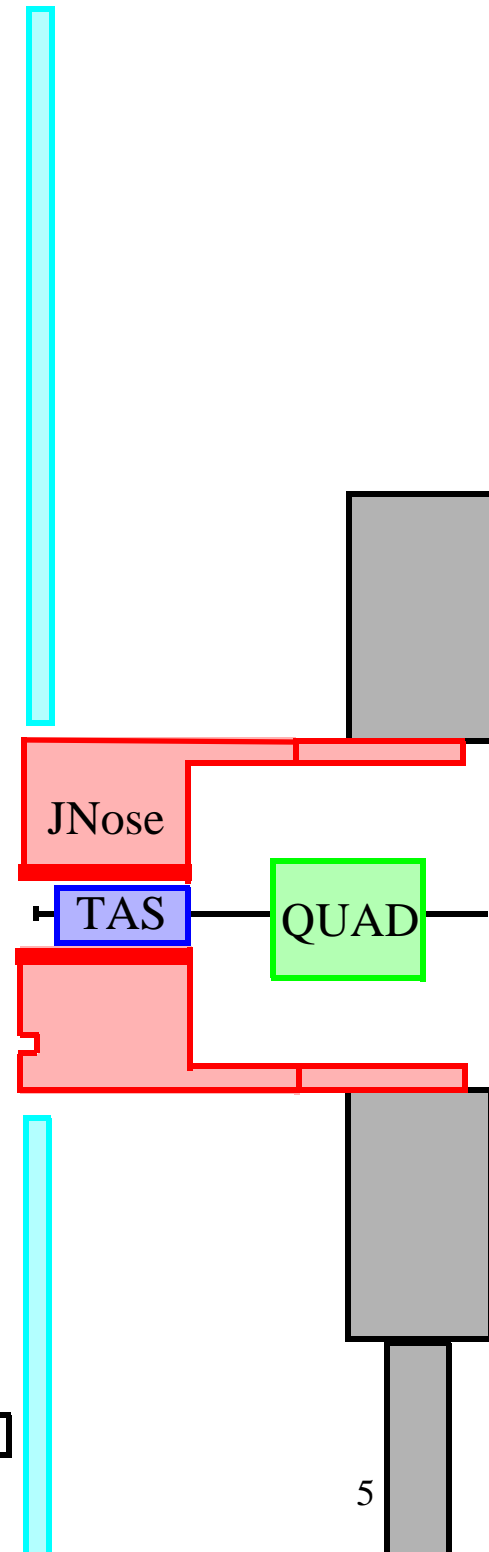
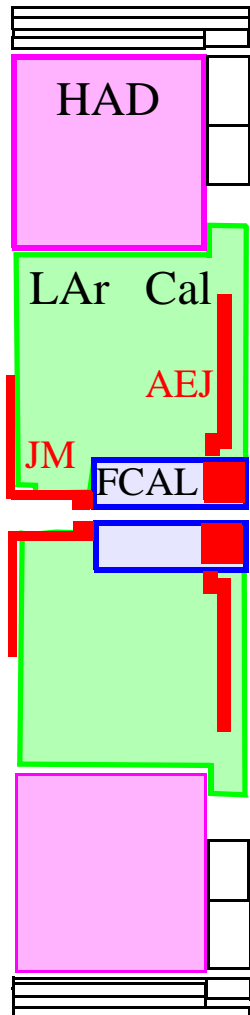
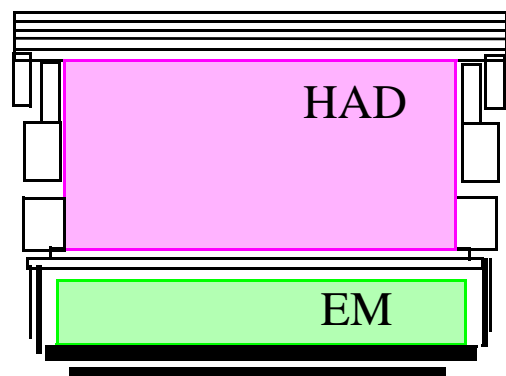

ACCESS

Rails

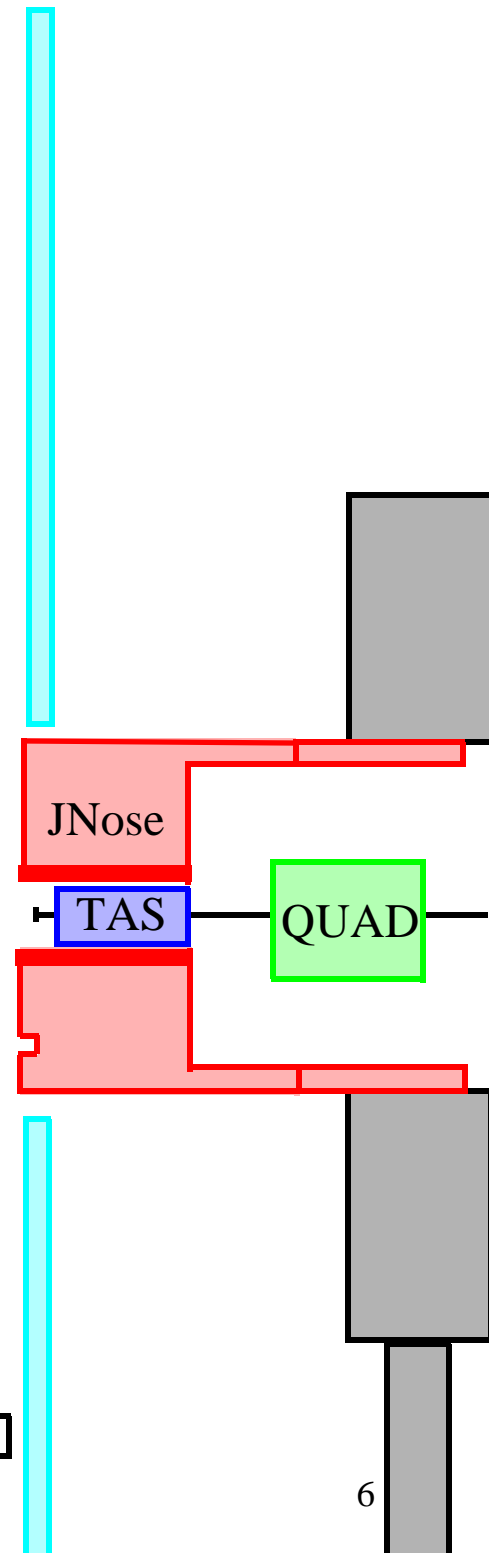
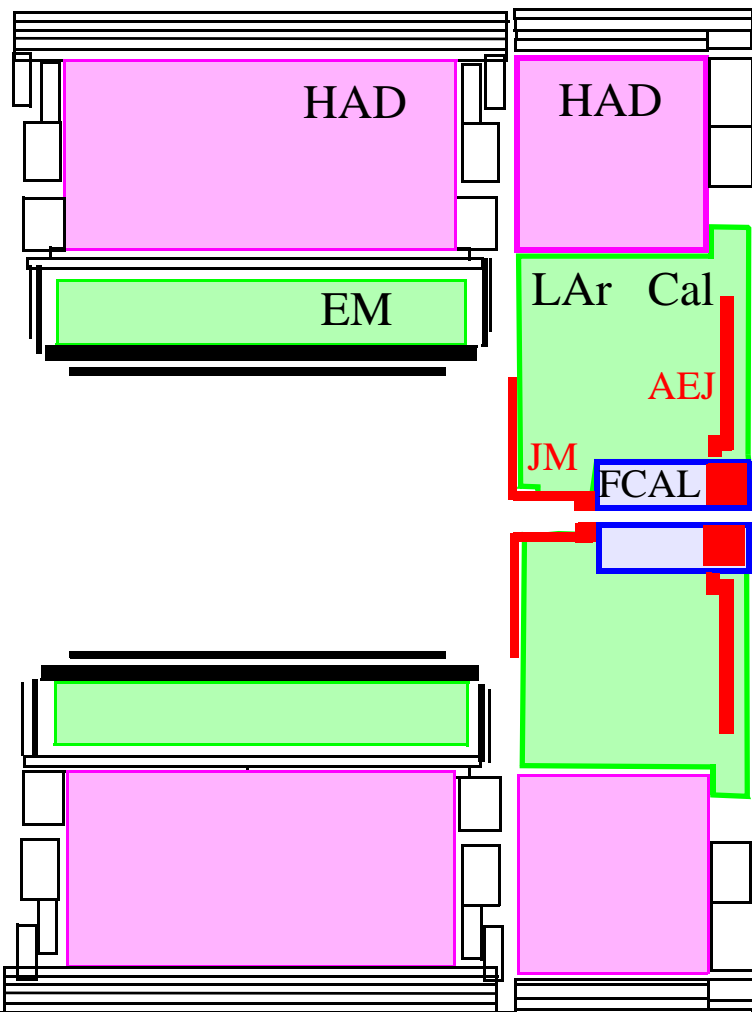

Rails

ACCESS

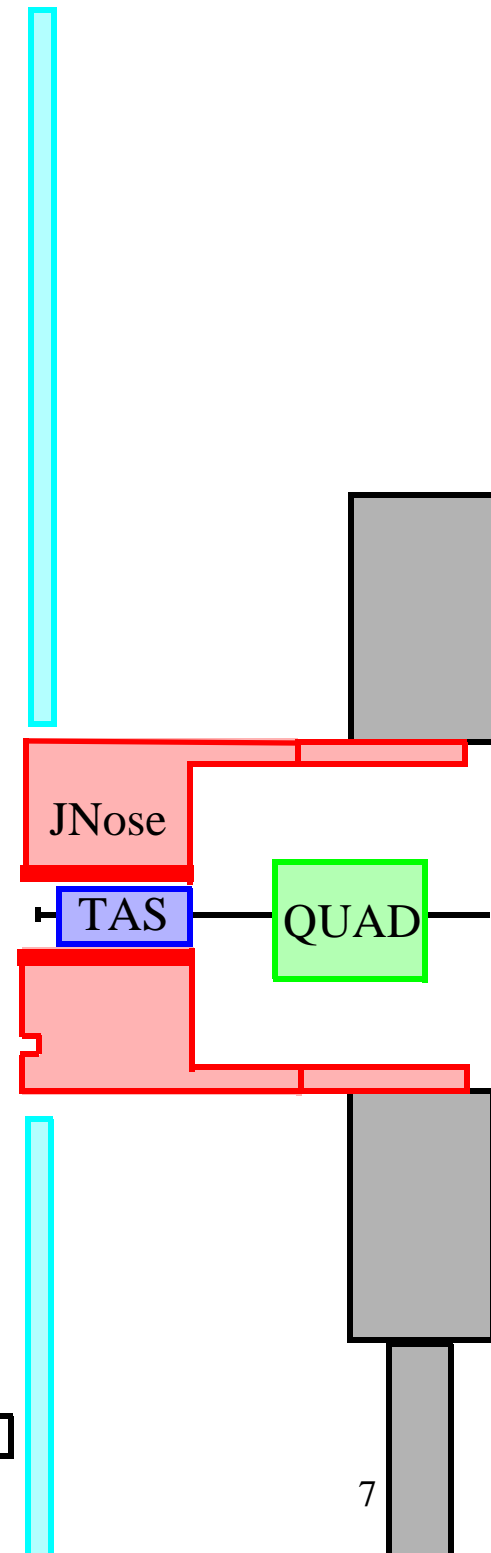
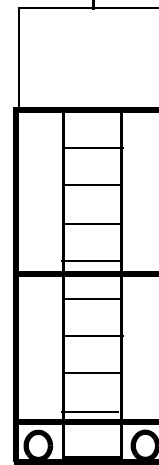
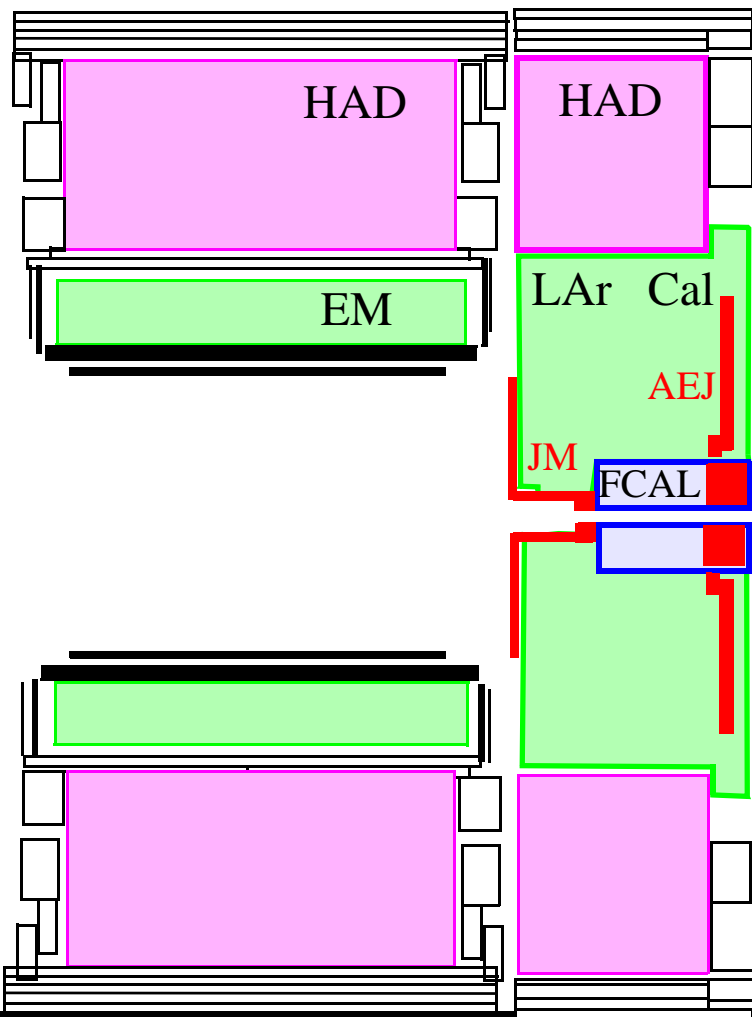

ACCESS

Rails

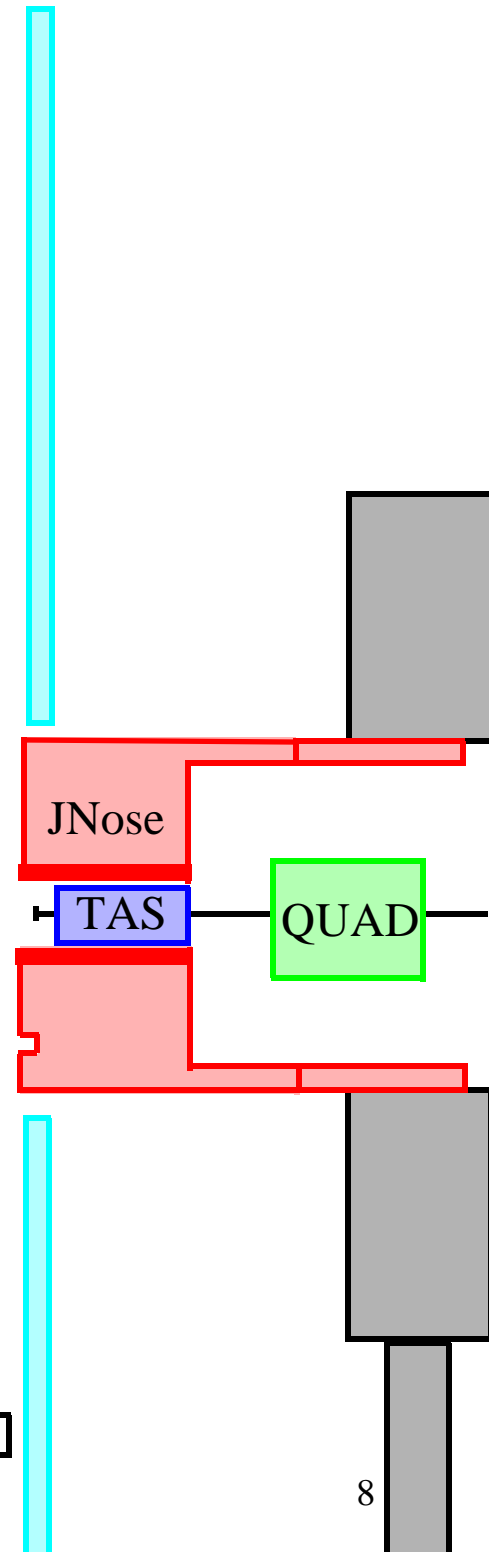
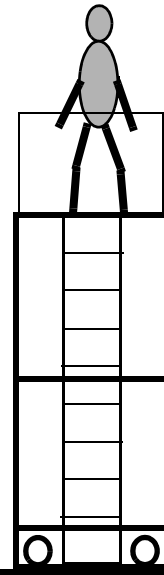
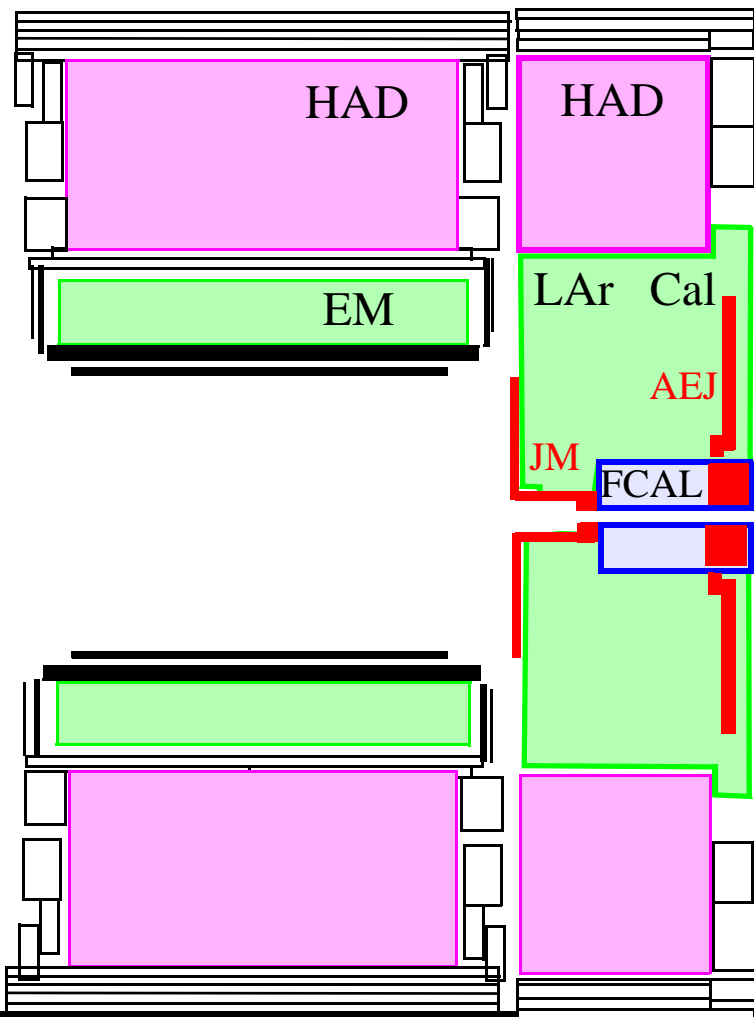

Rails

ACCESS

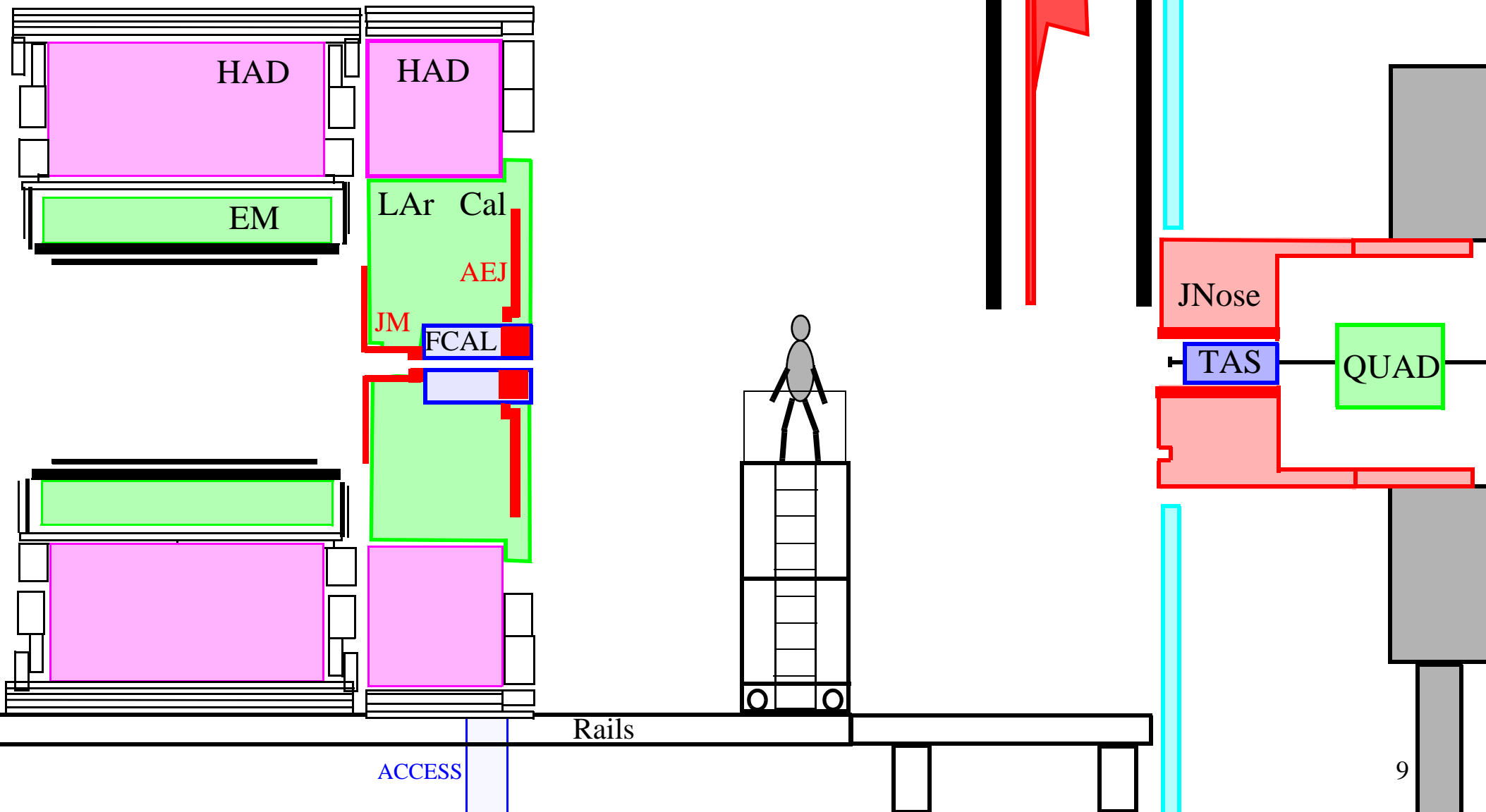

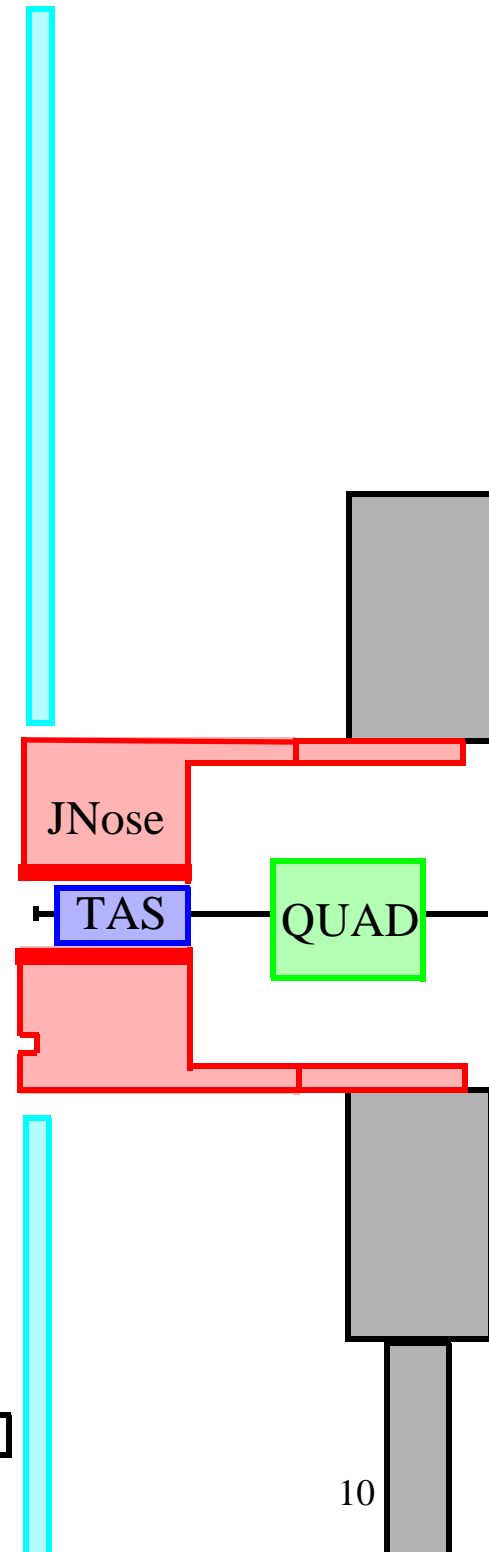
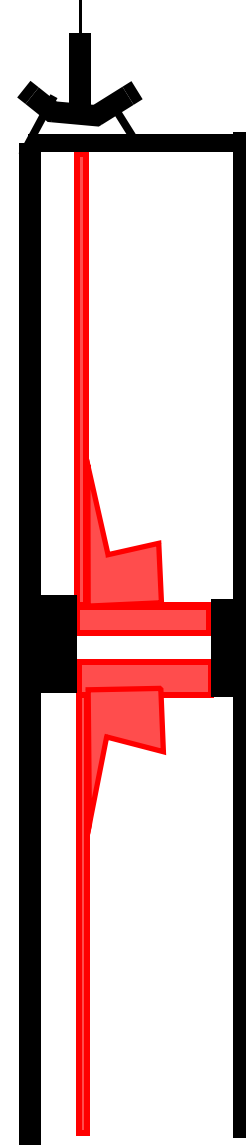
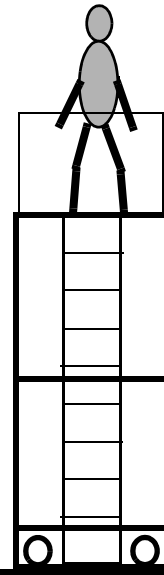
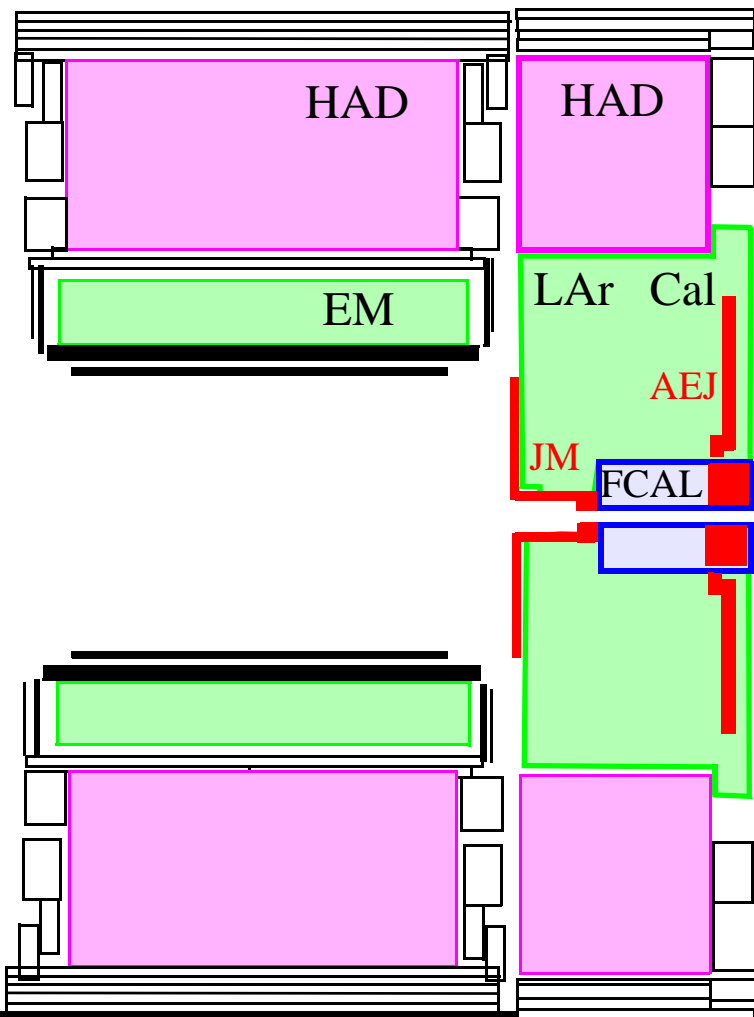

Rails

ACCESS

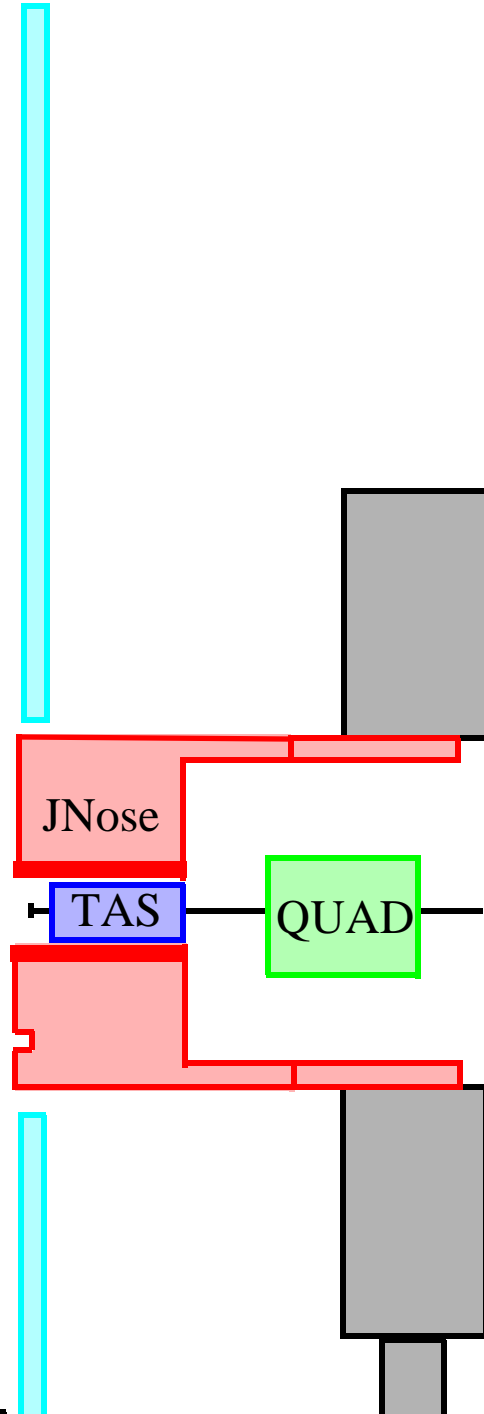
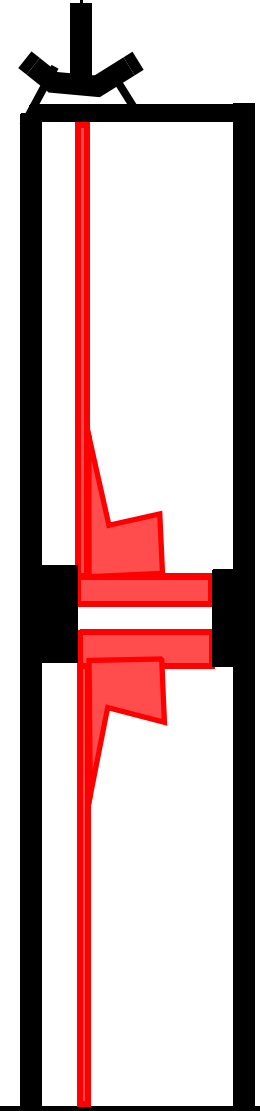
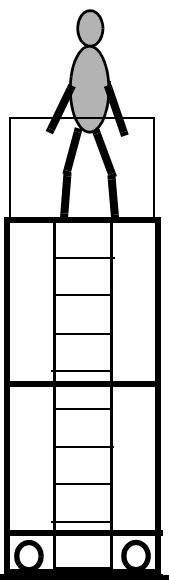
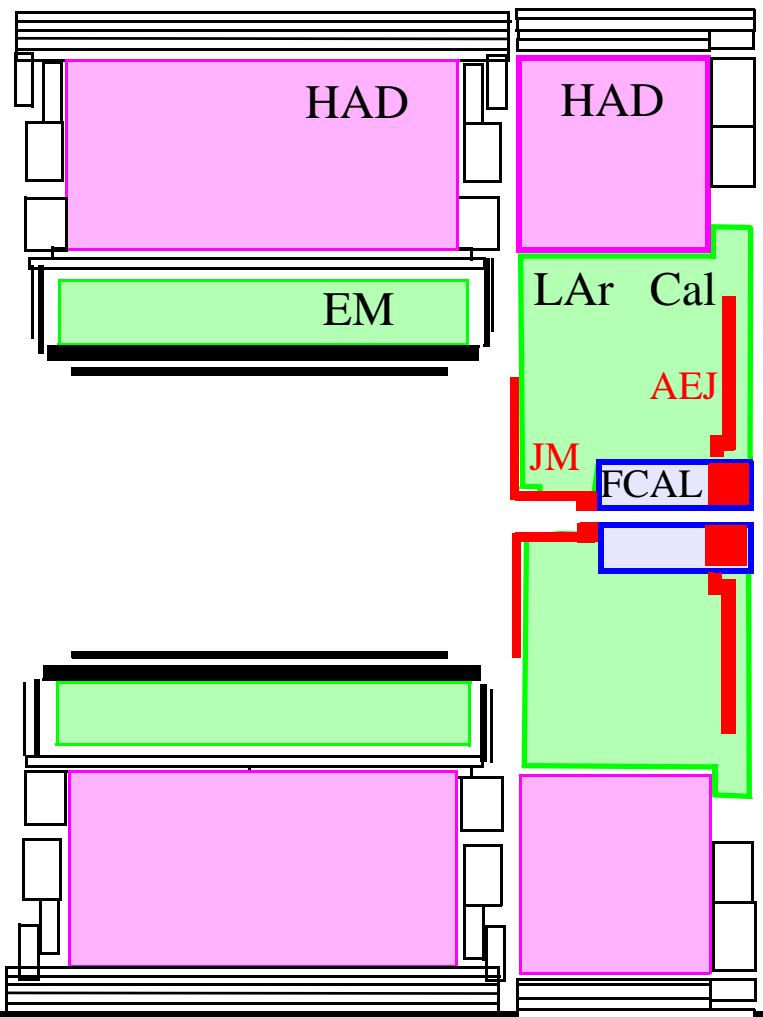

ACCESS
Rails

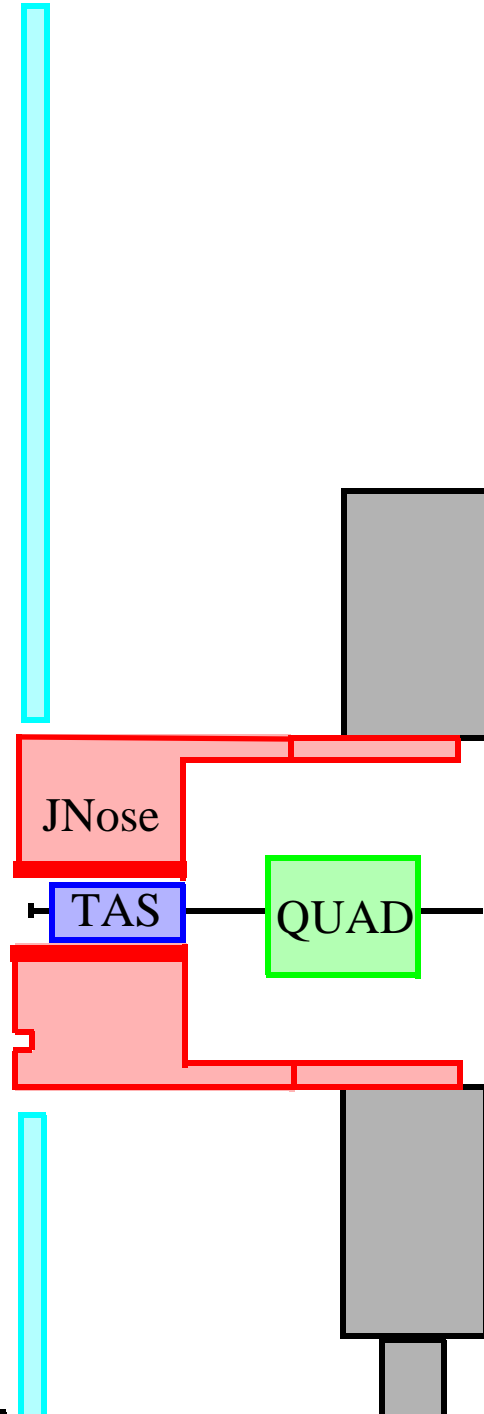
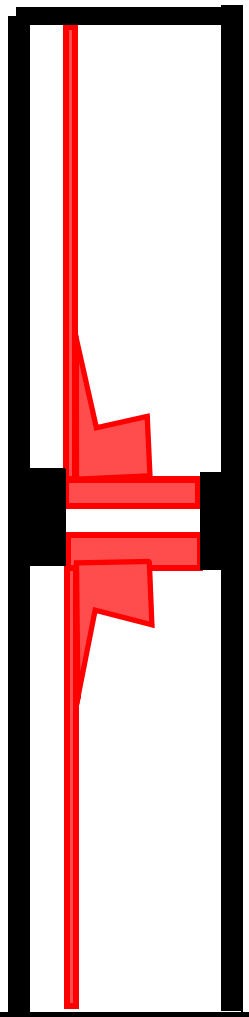
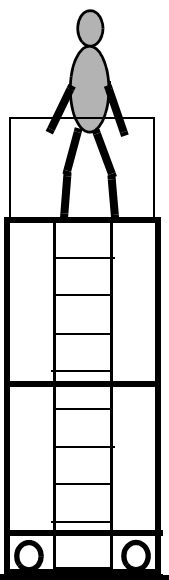
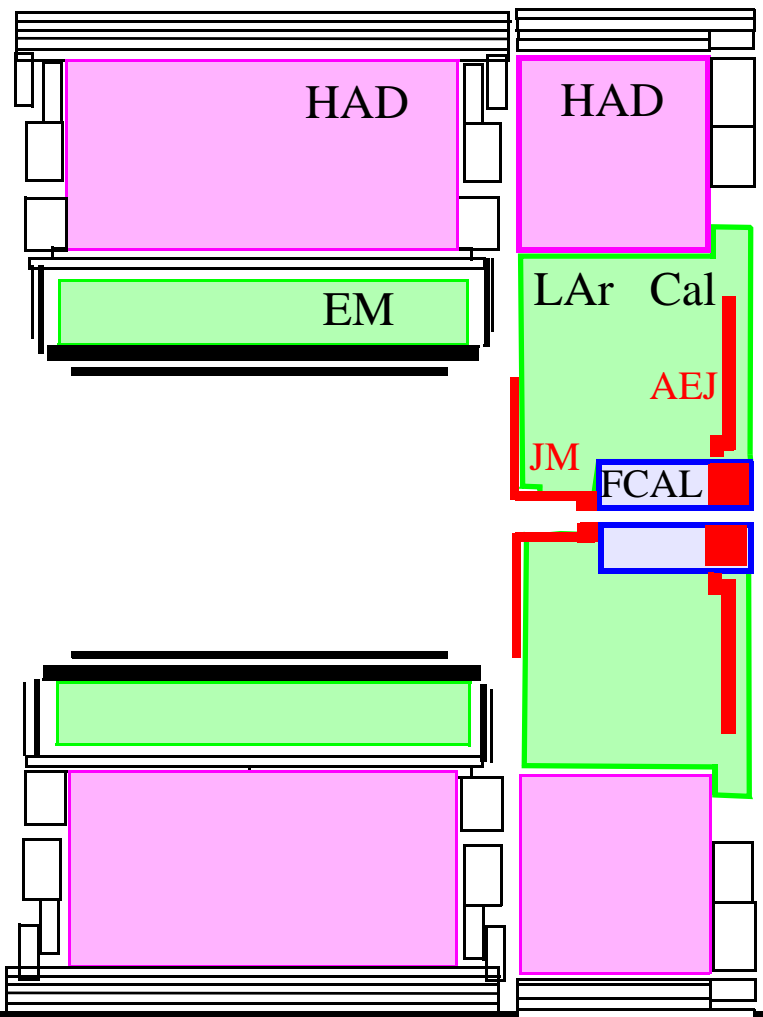

Rails

ACCESS

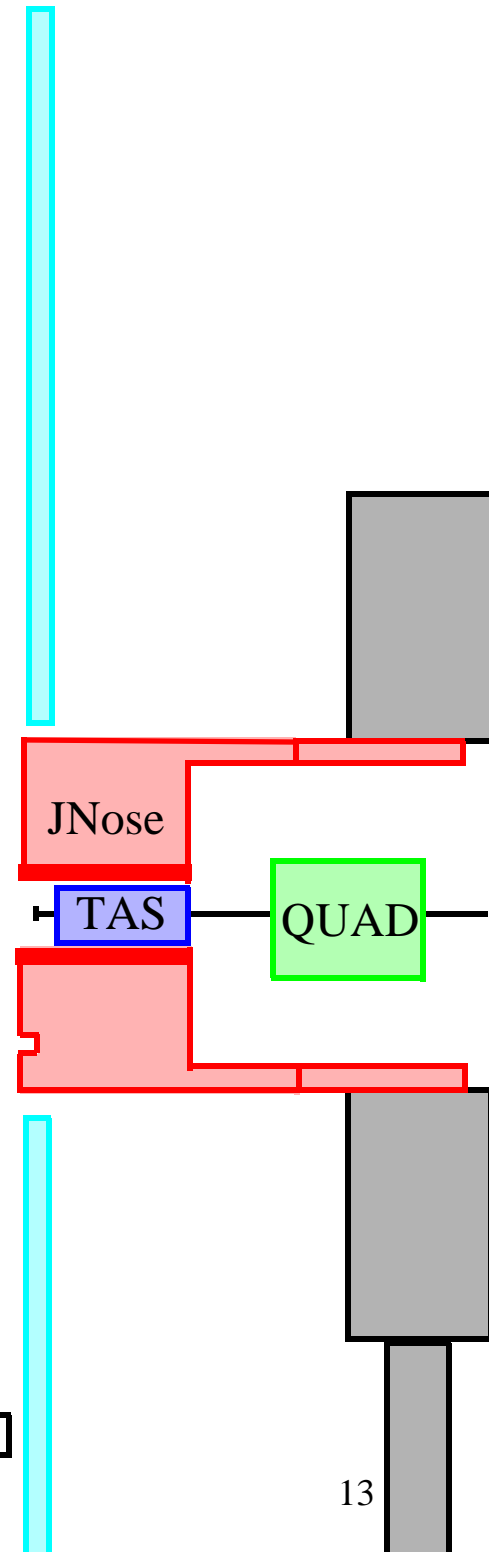
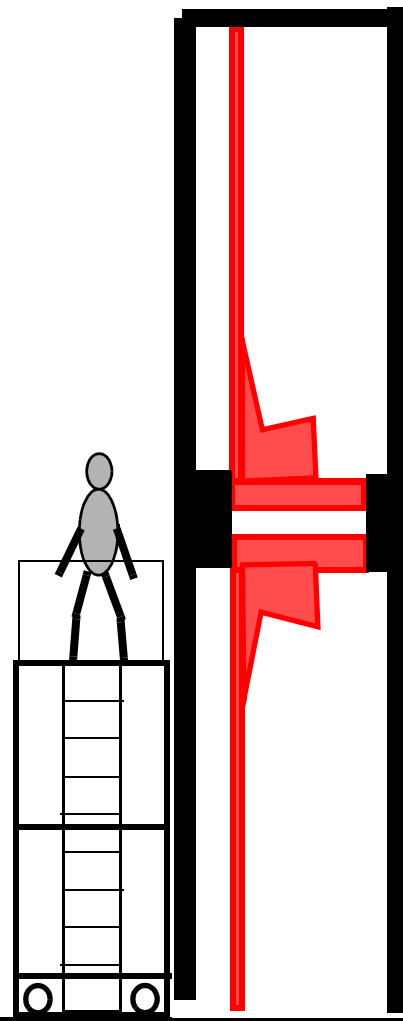
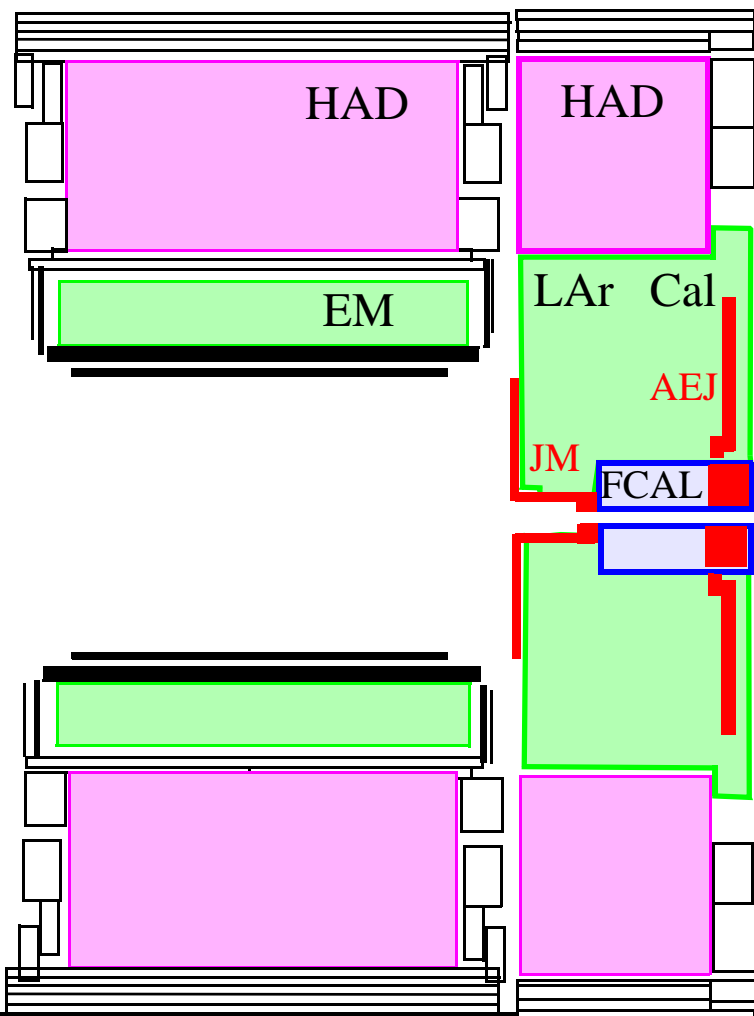

Rails

ACCESS

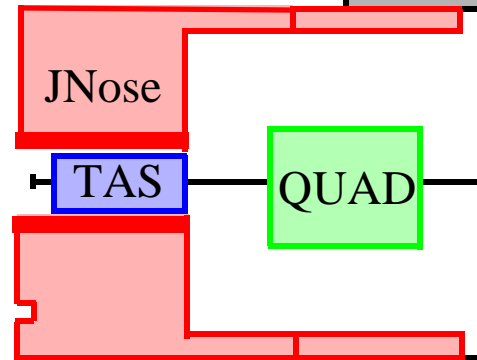
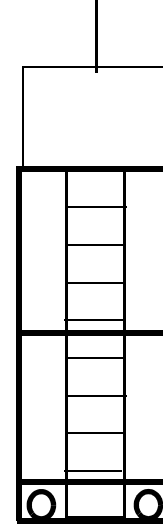
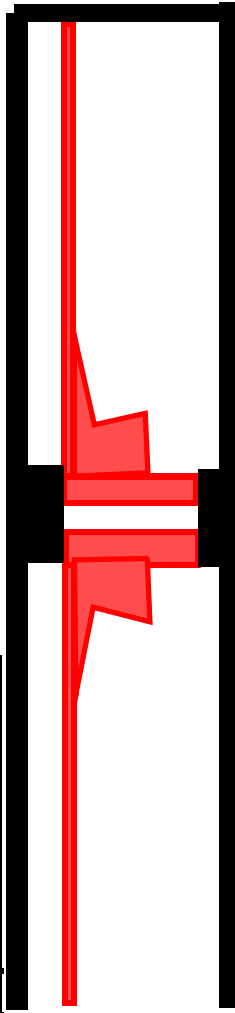
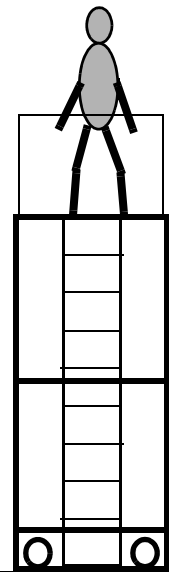
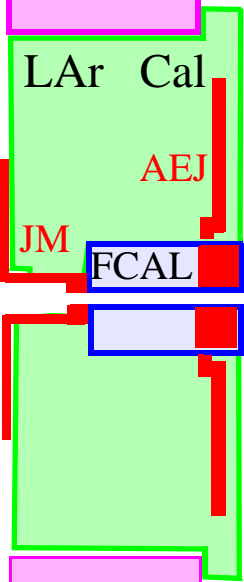
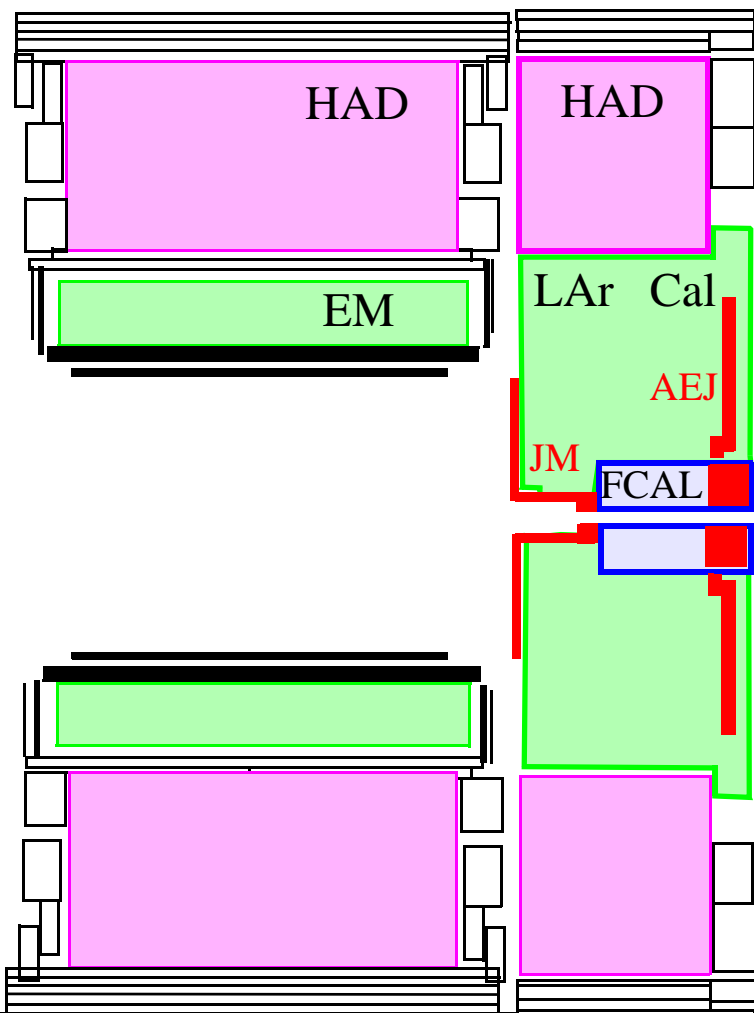

Rails

ACCESS

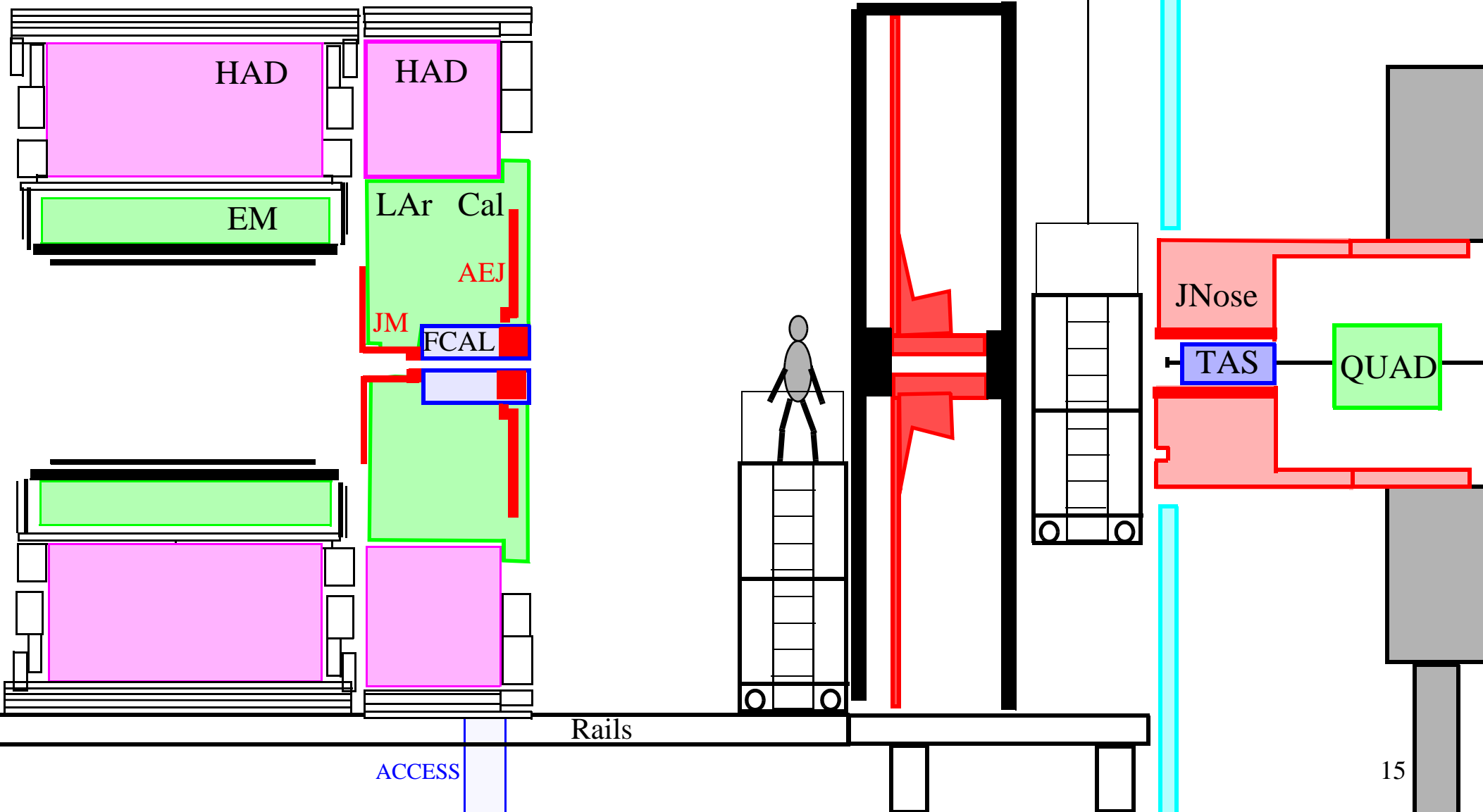

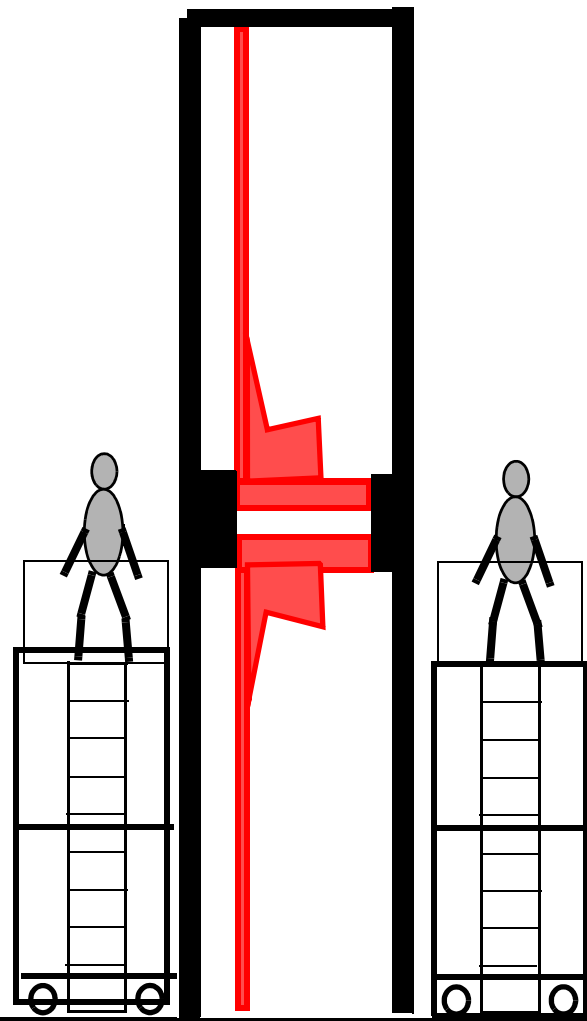
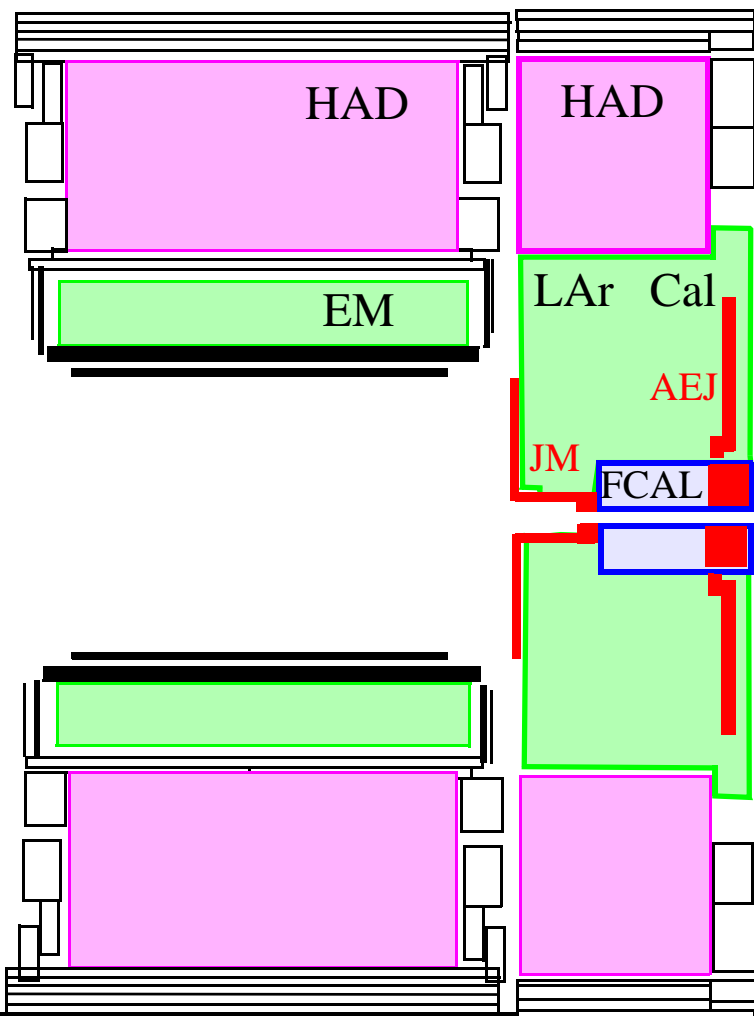

Rails

ACCESS

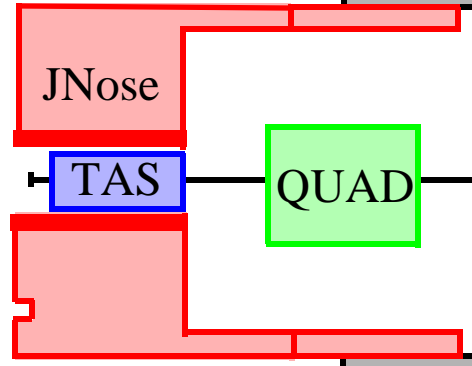
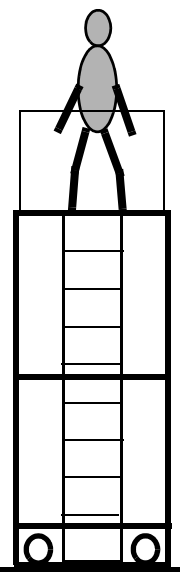
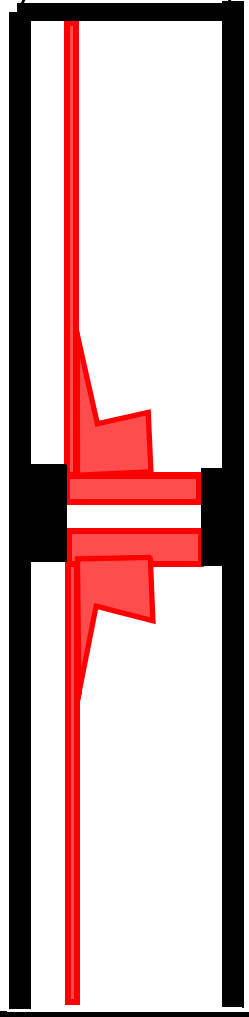
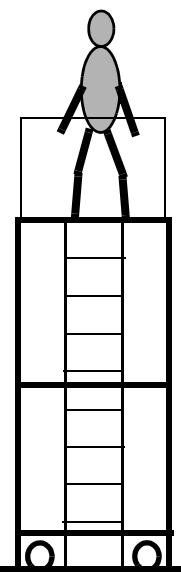
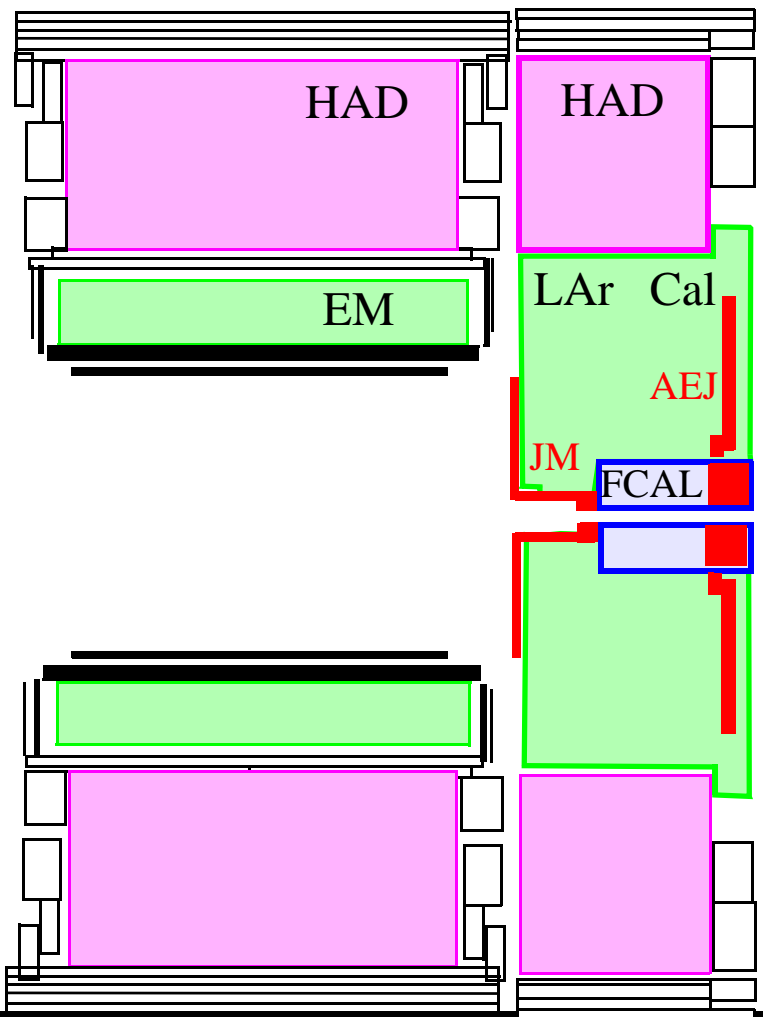

Rails

ACCESS

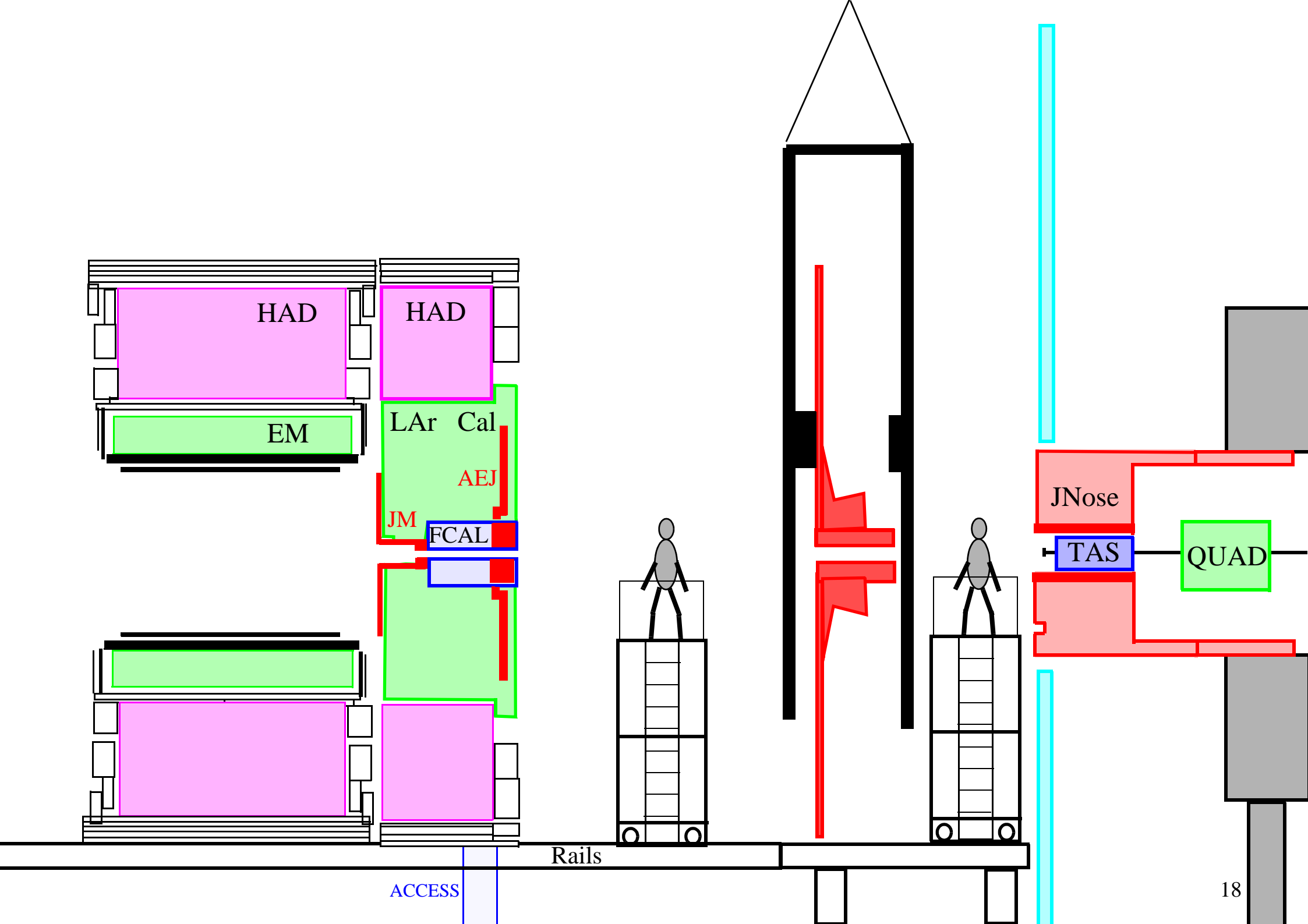

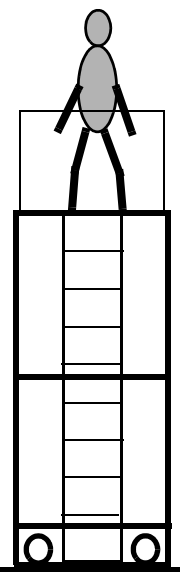
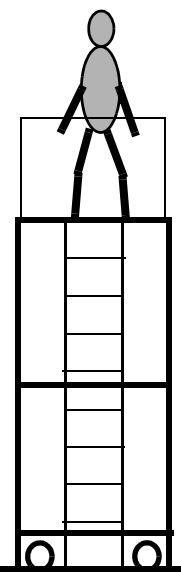
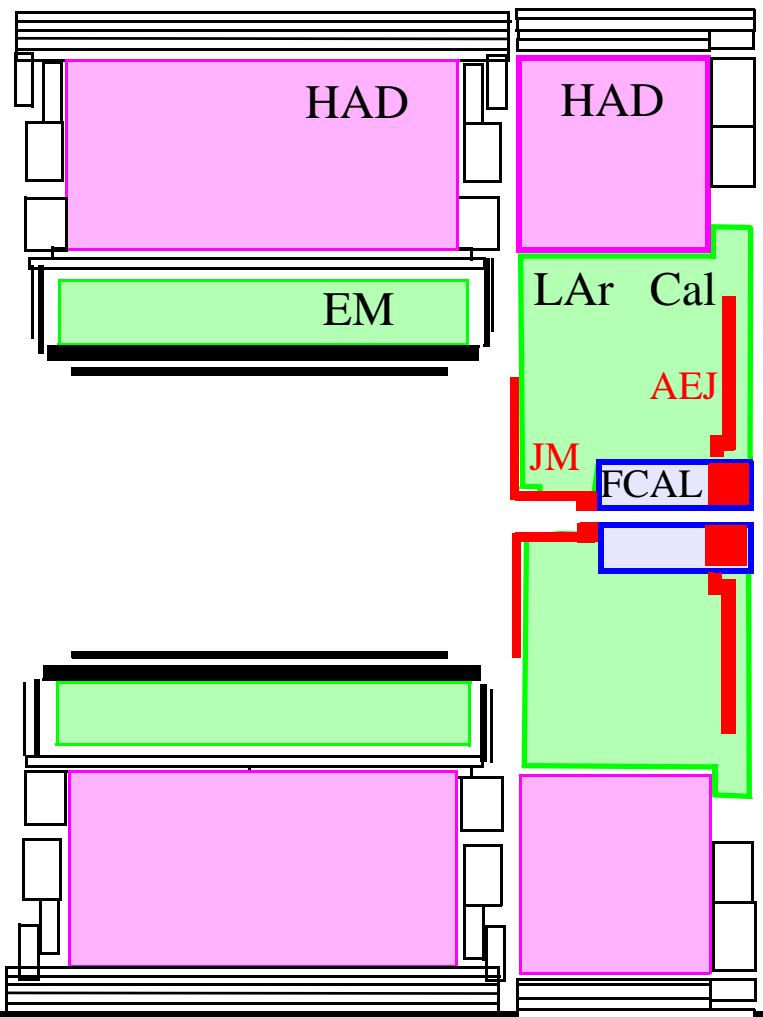

Rails

ACCESS

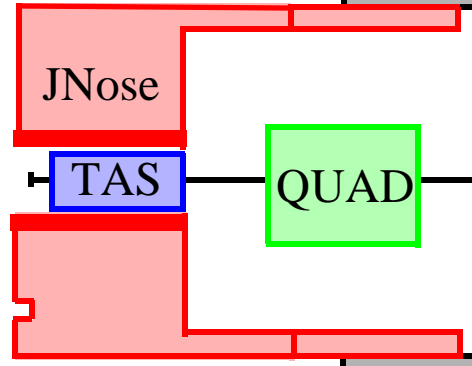
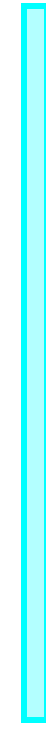
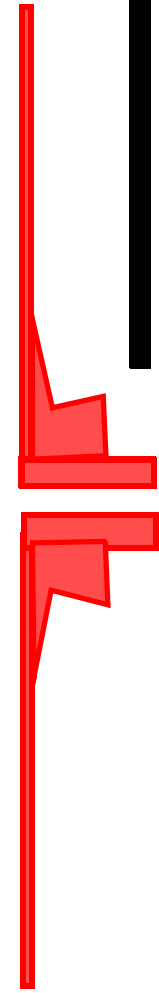
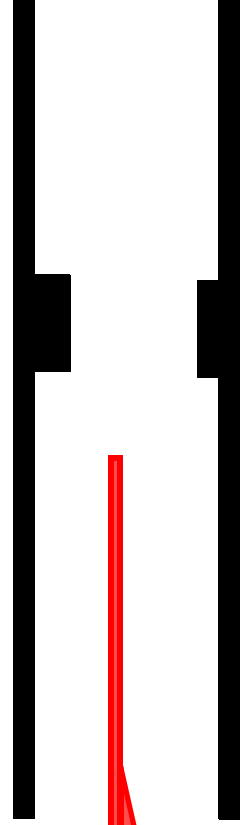

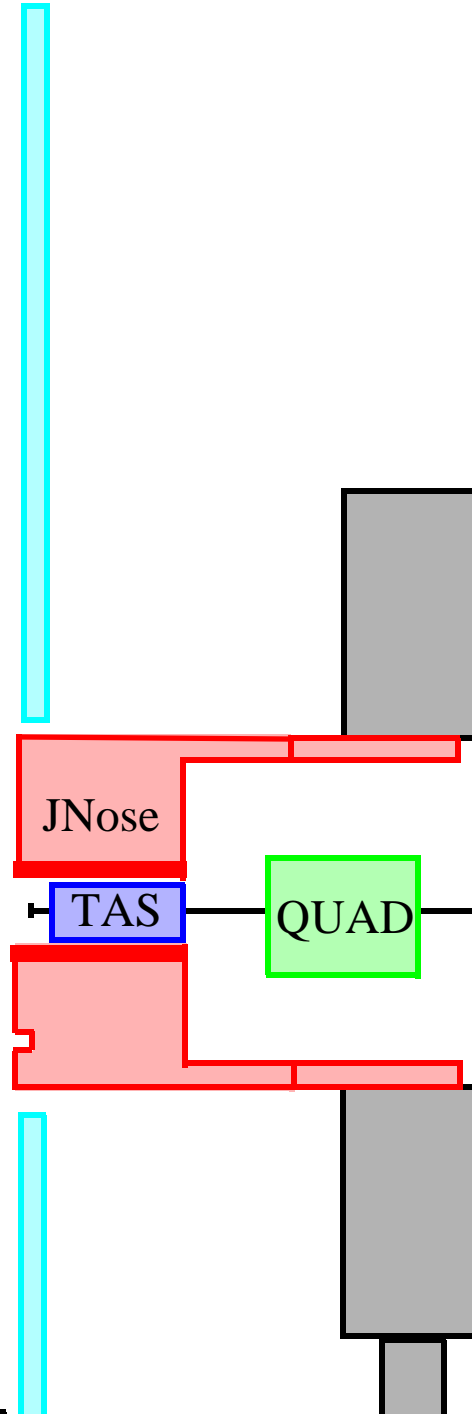
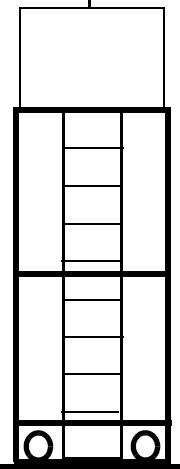
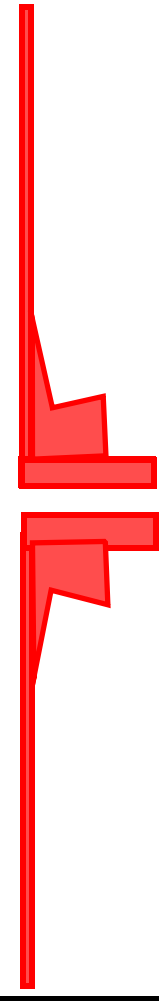
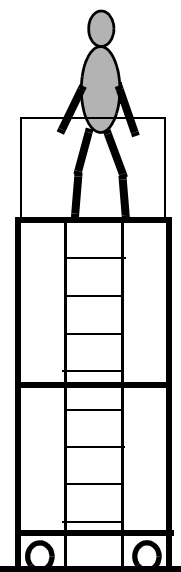
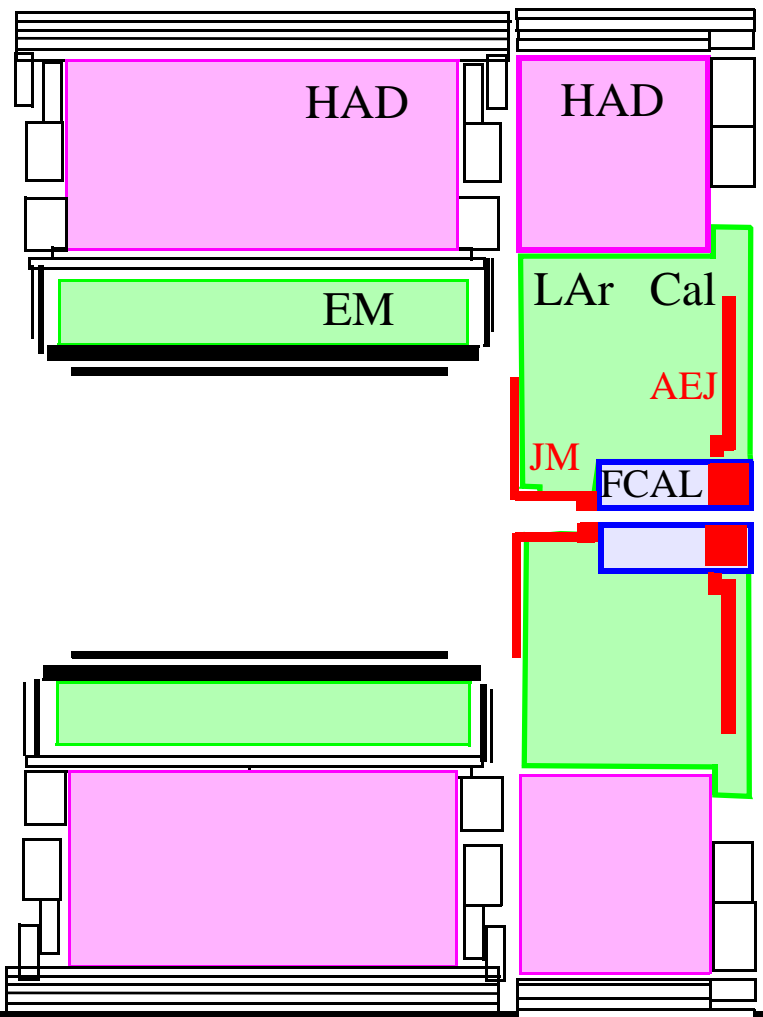

Rails

ACCESS

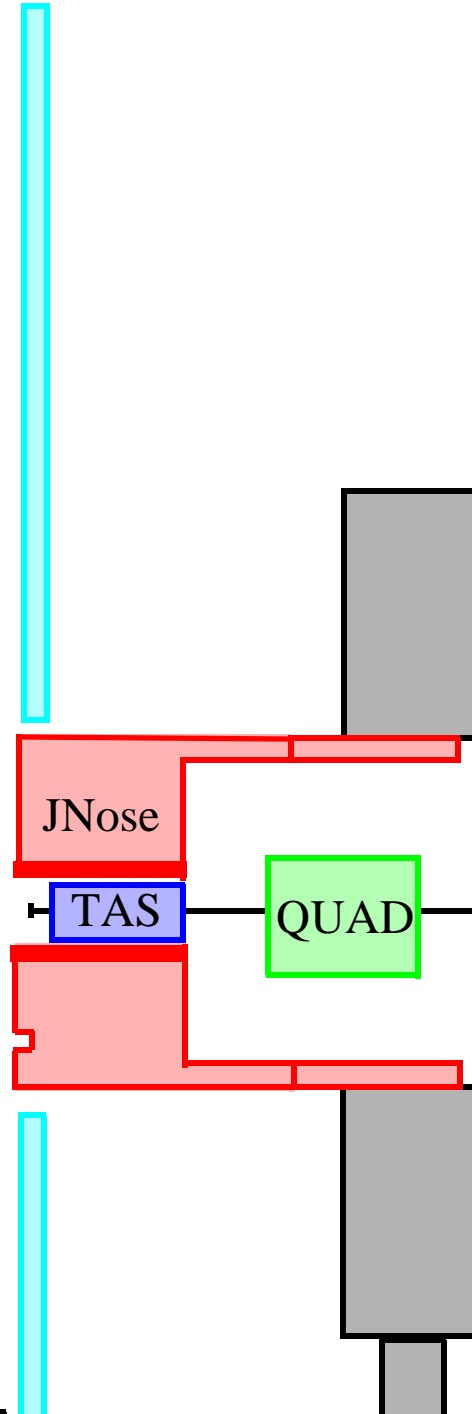
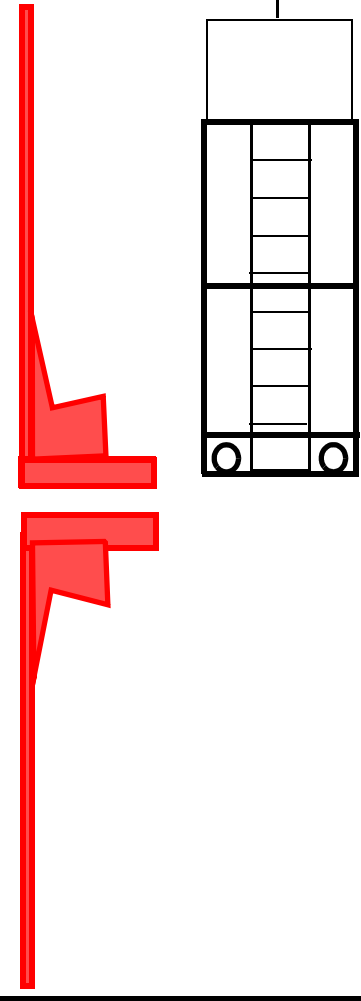
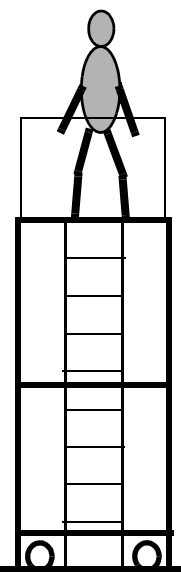
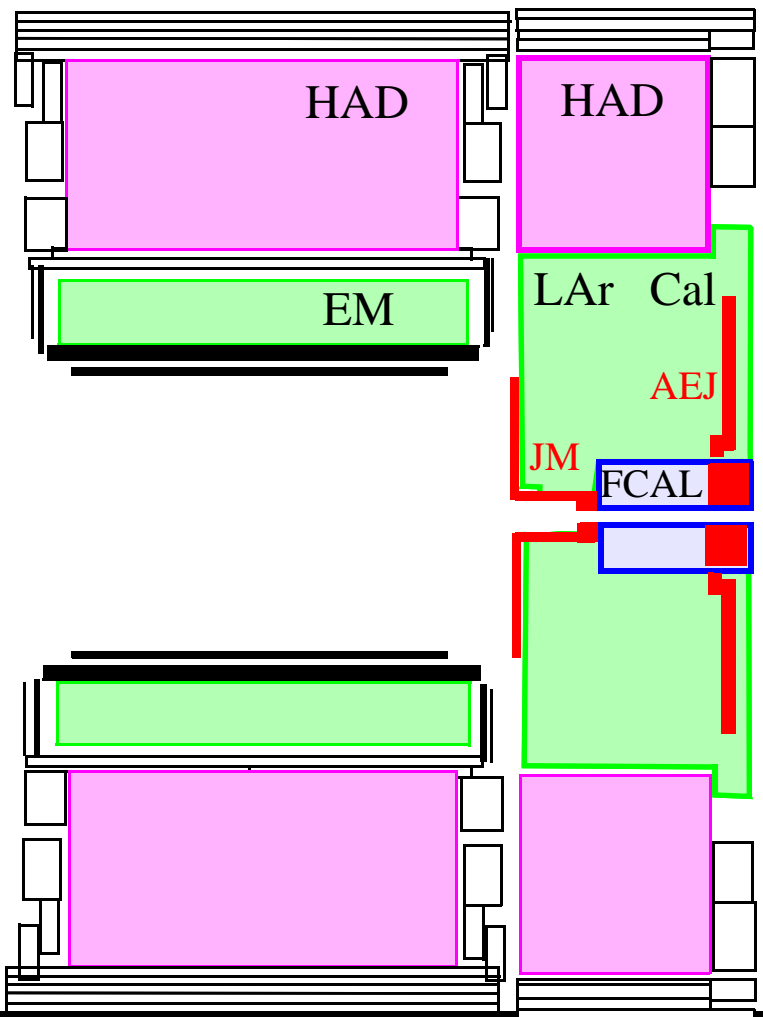

ACCESS

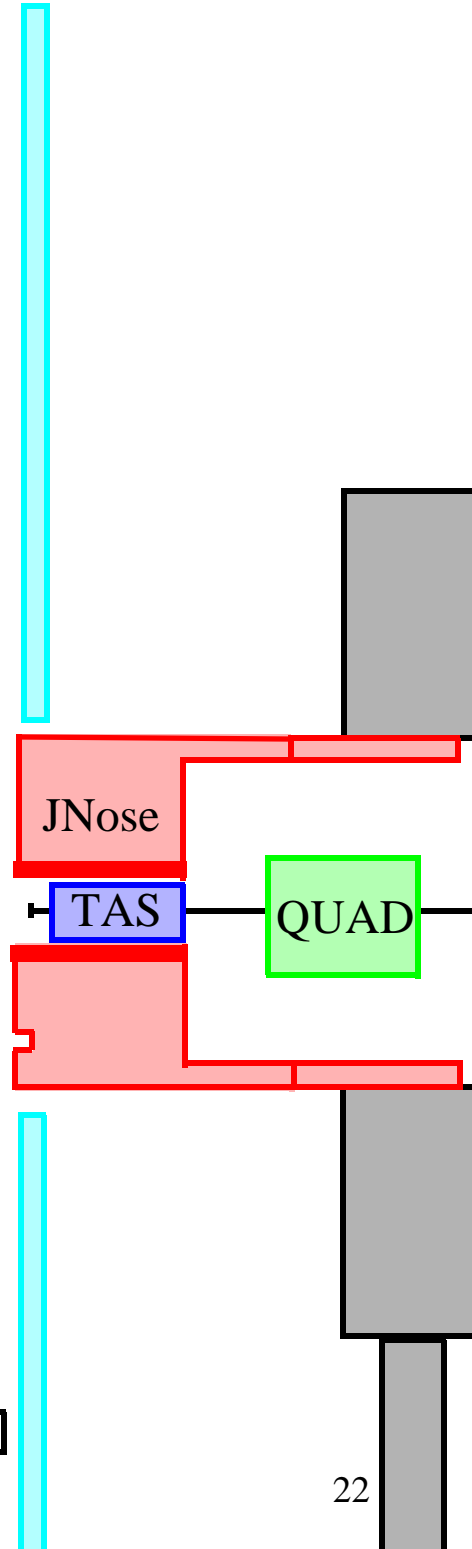
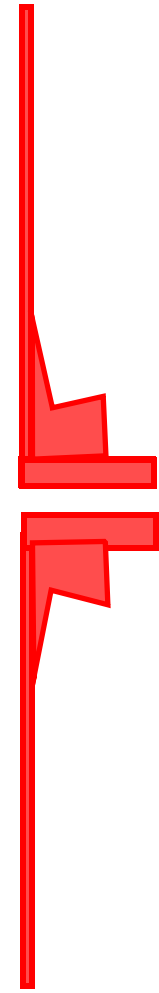
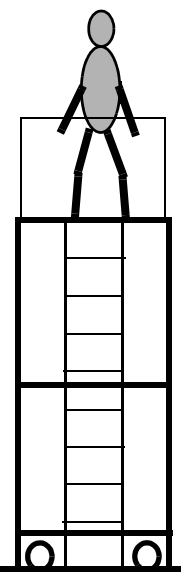
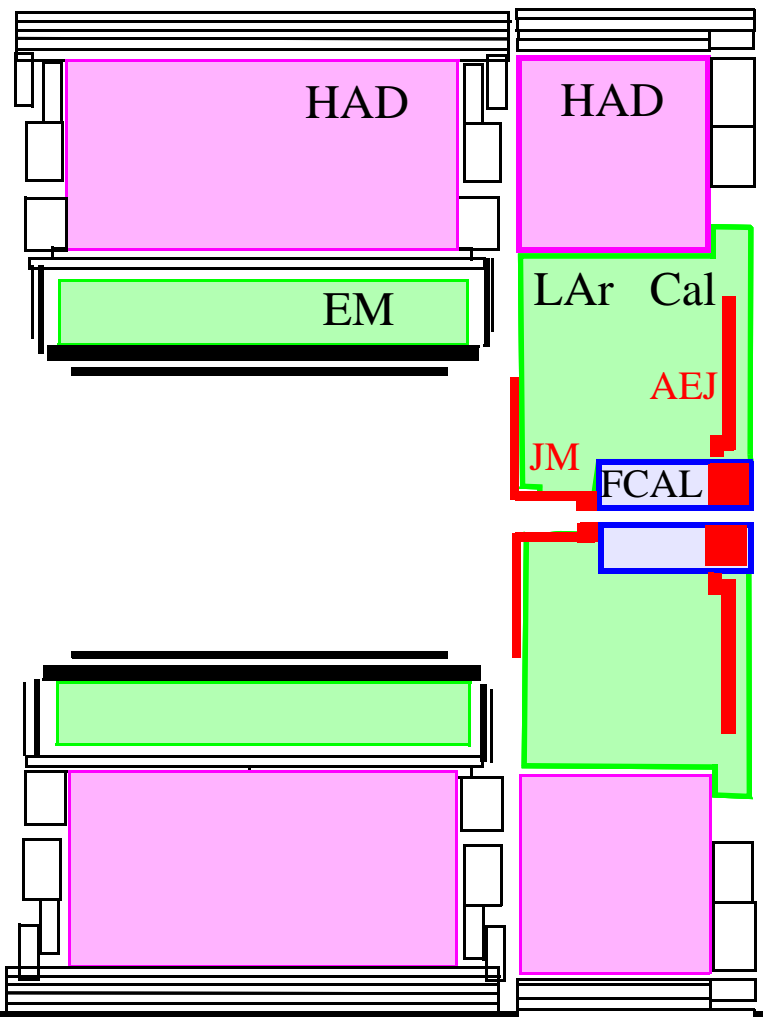

ACCESS

Rails

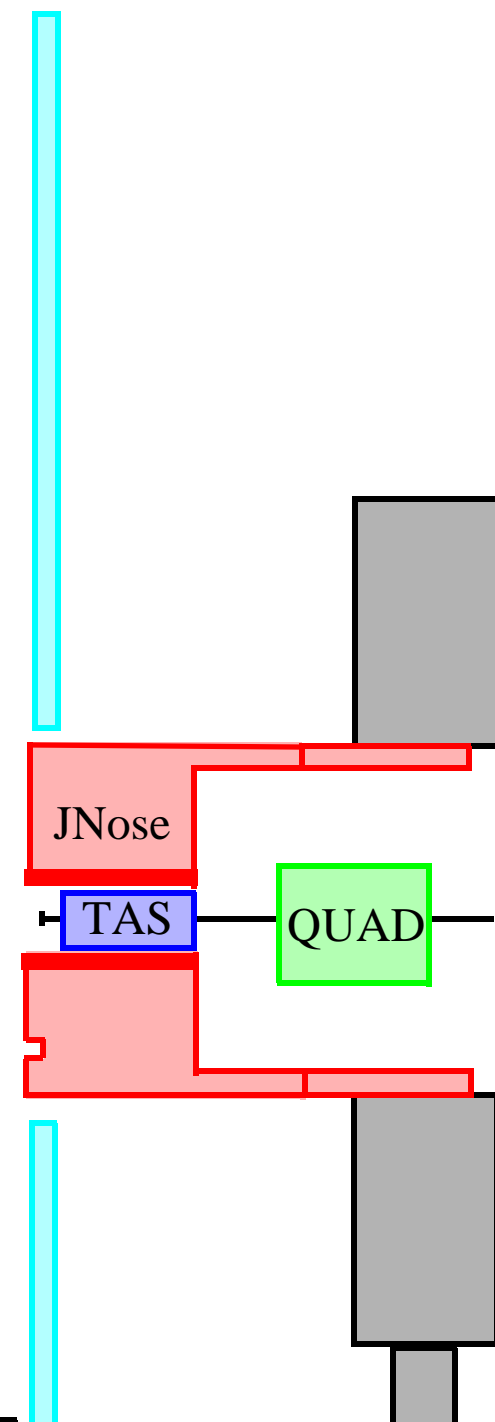
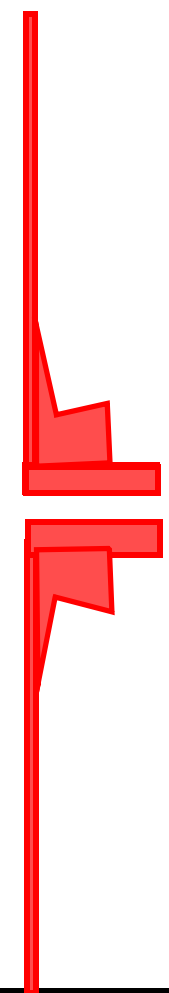
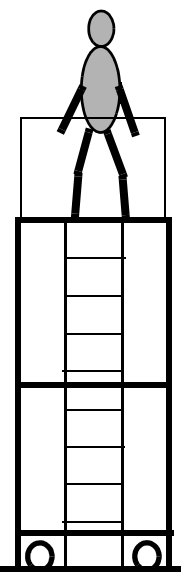
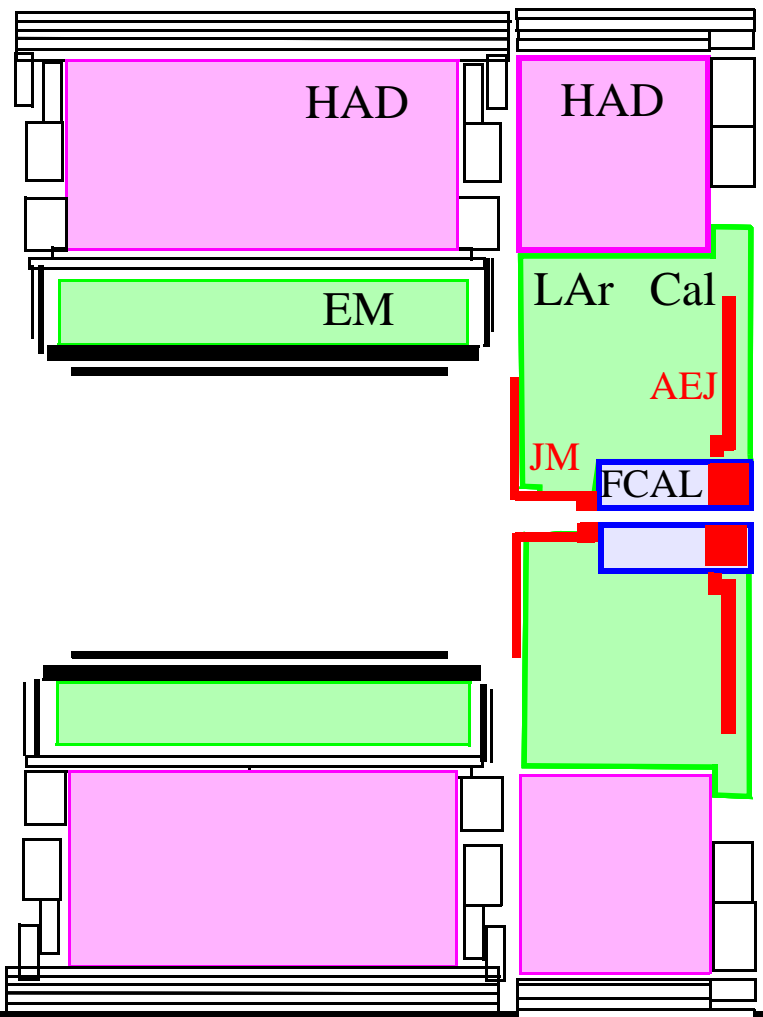

ACCESS

Rails

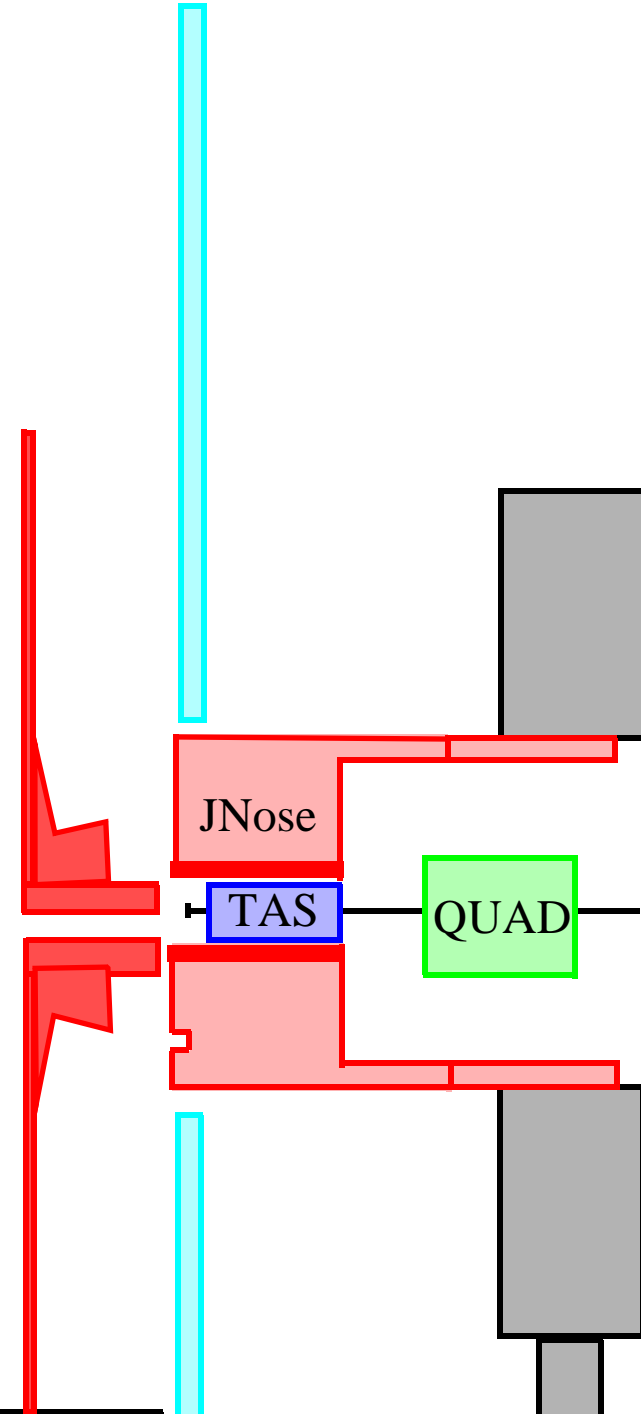
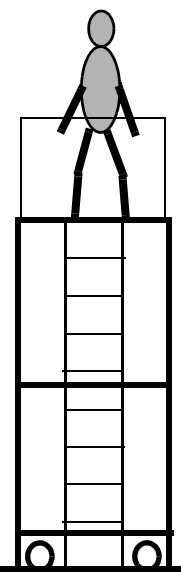
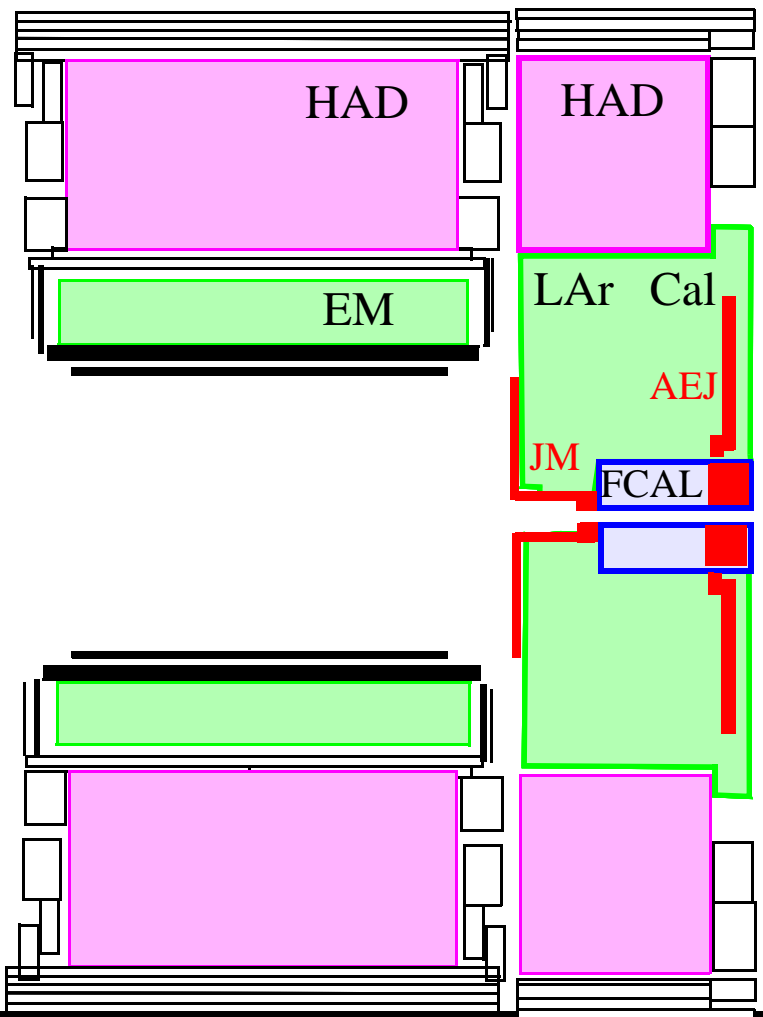

Rails

ACCESS

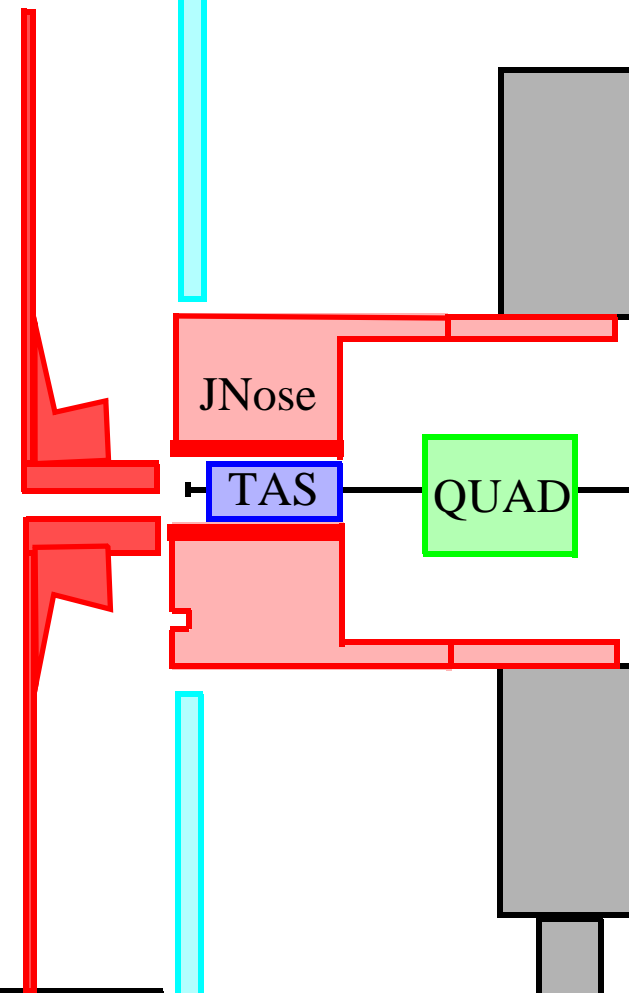
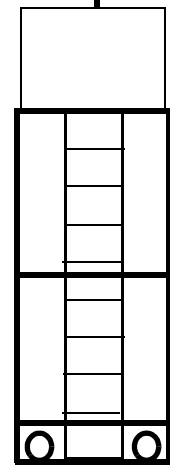
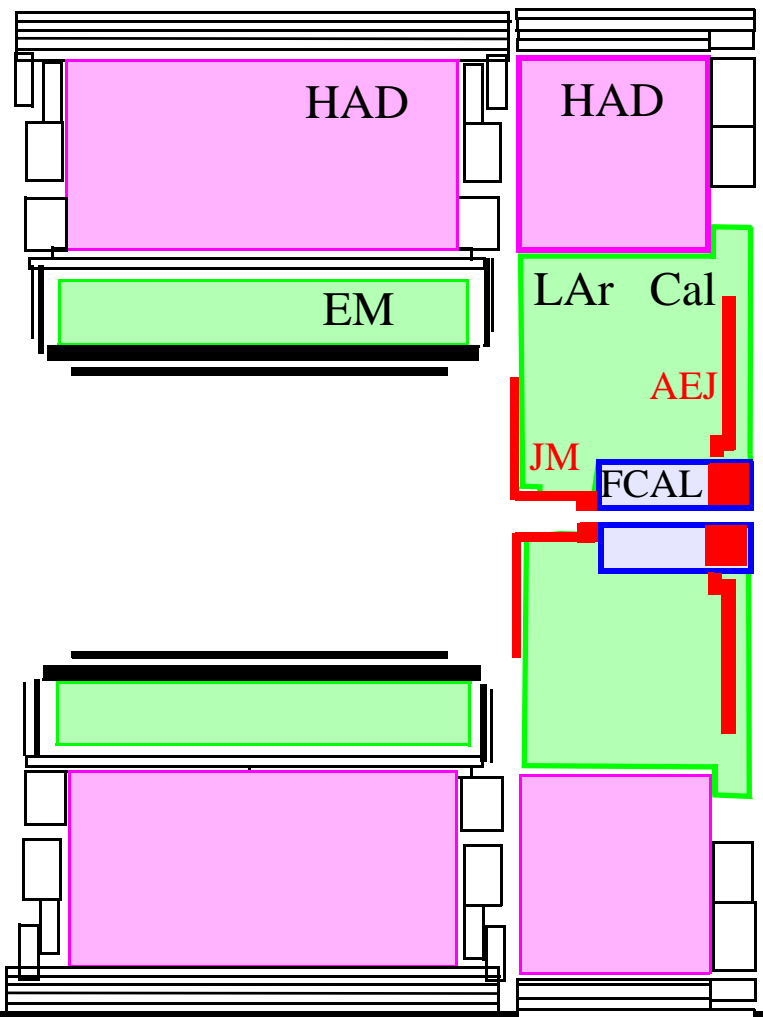

ACCESS

Rails

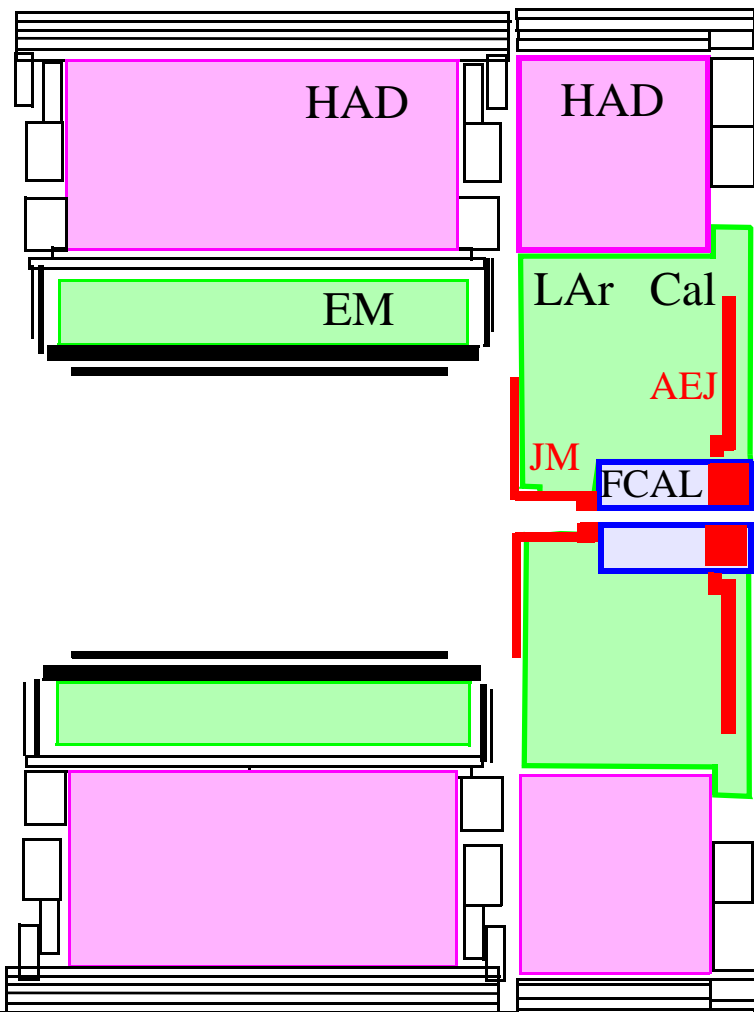

ACCESS

Rails

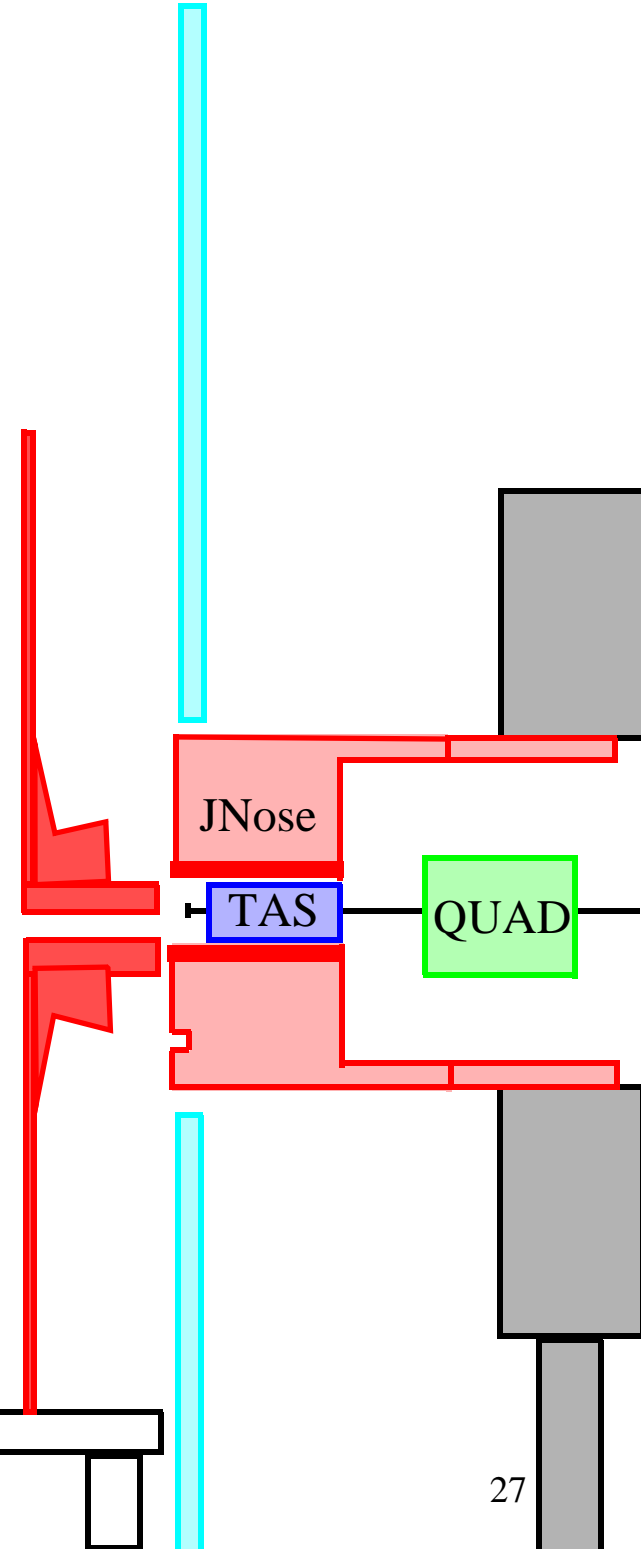

JNose

TAS

QUAD

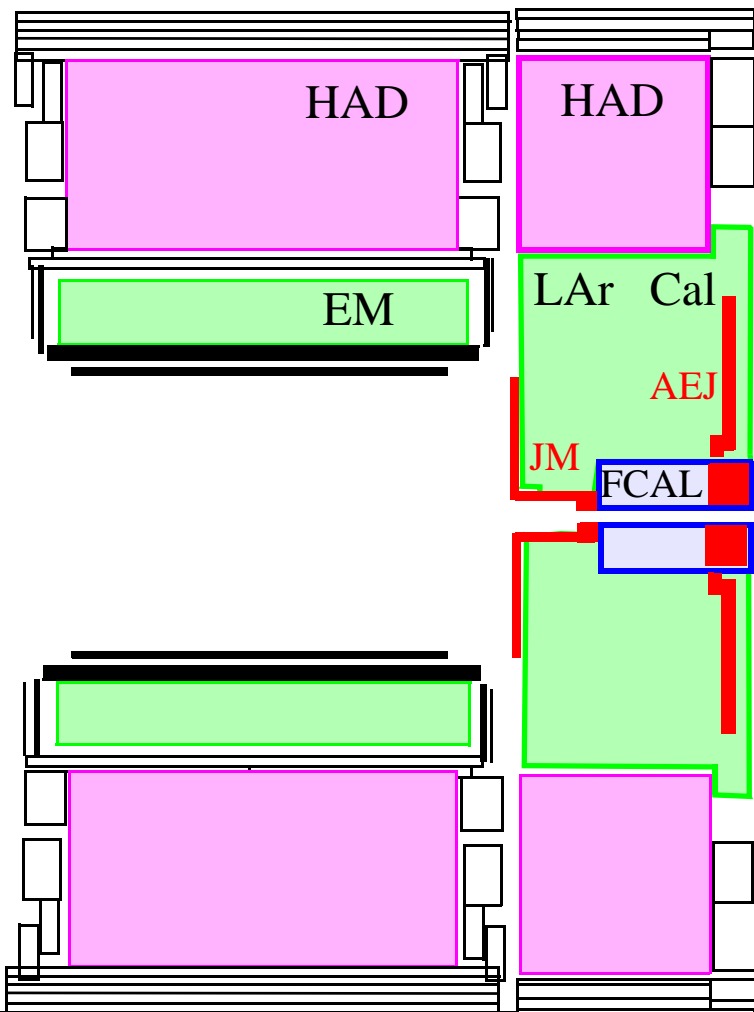

ACCESS

Rails

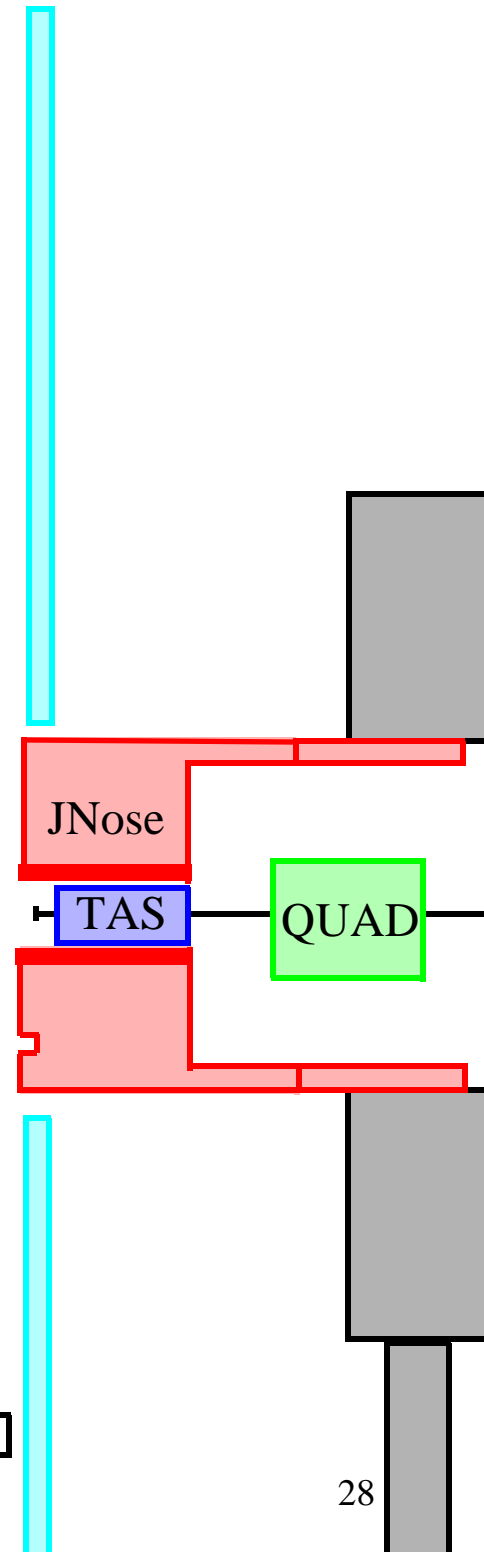

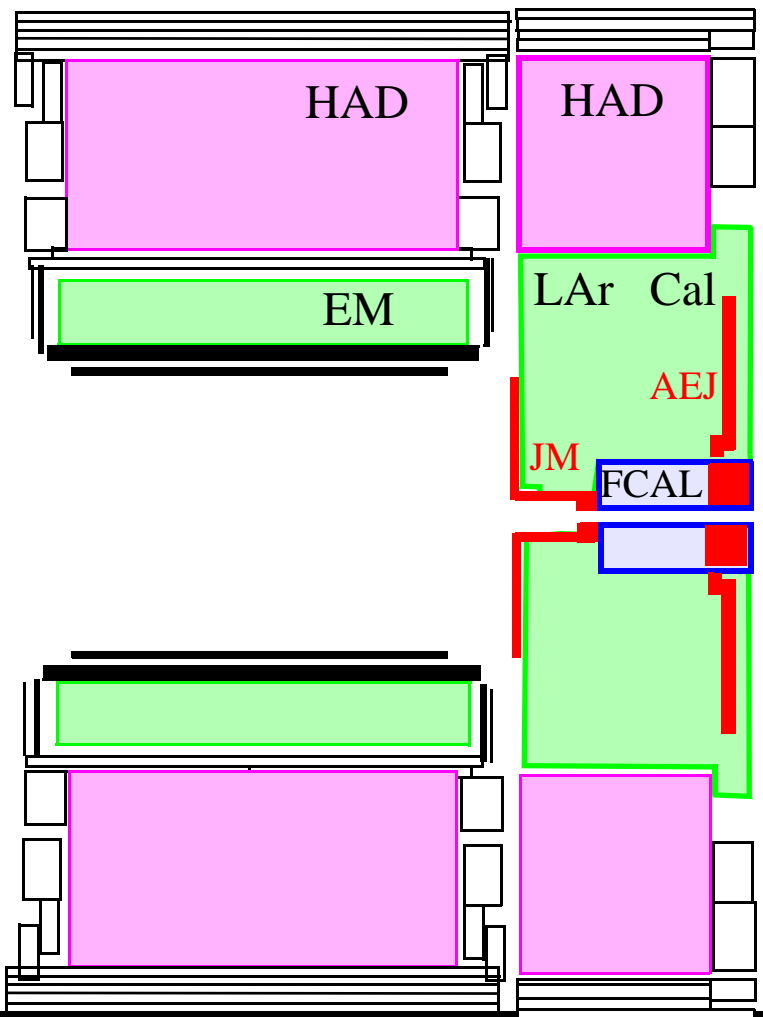

Rails

ACCESS

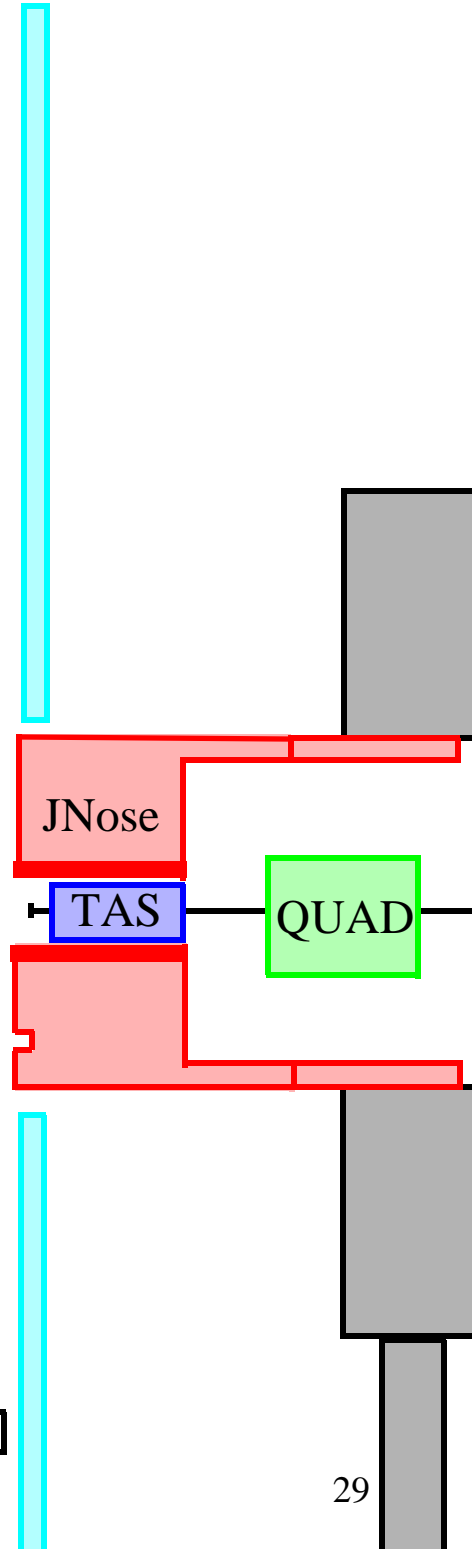

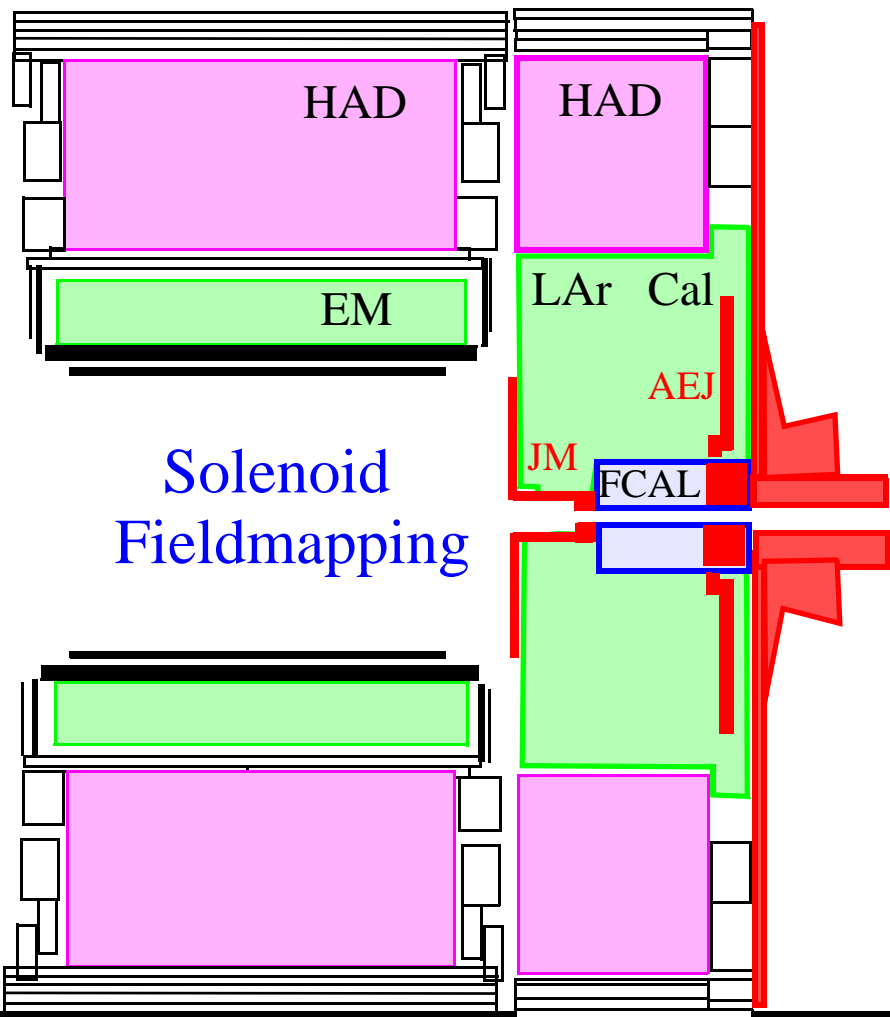

Solenoid
Fieldmapping

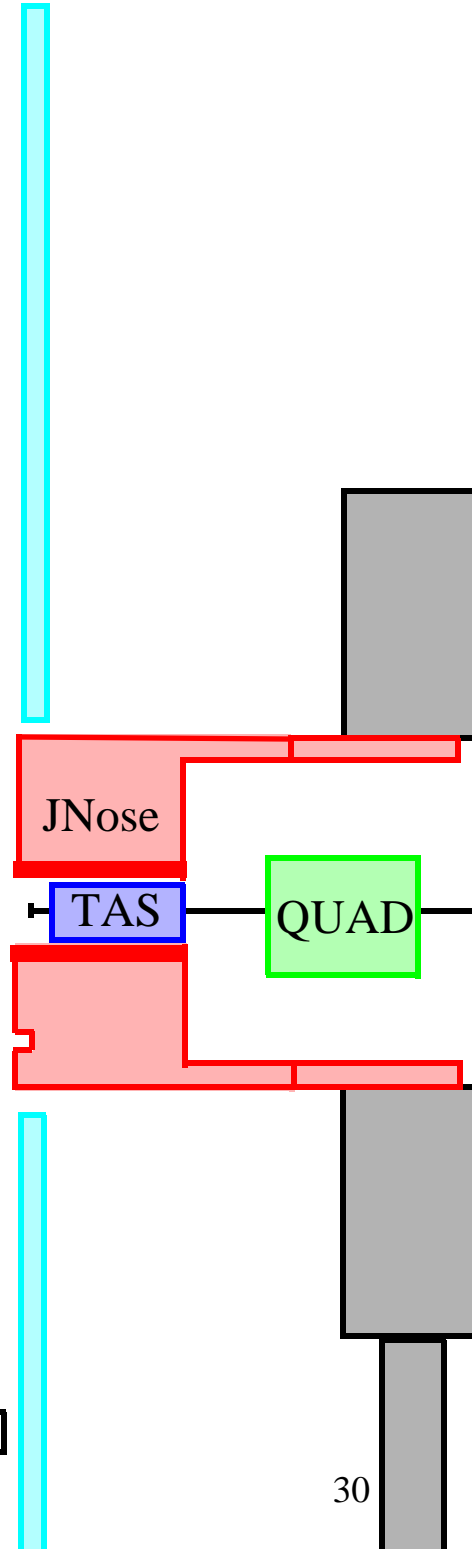

ACCESS

Rails

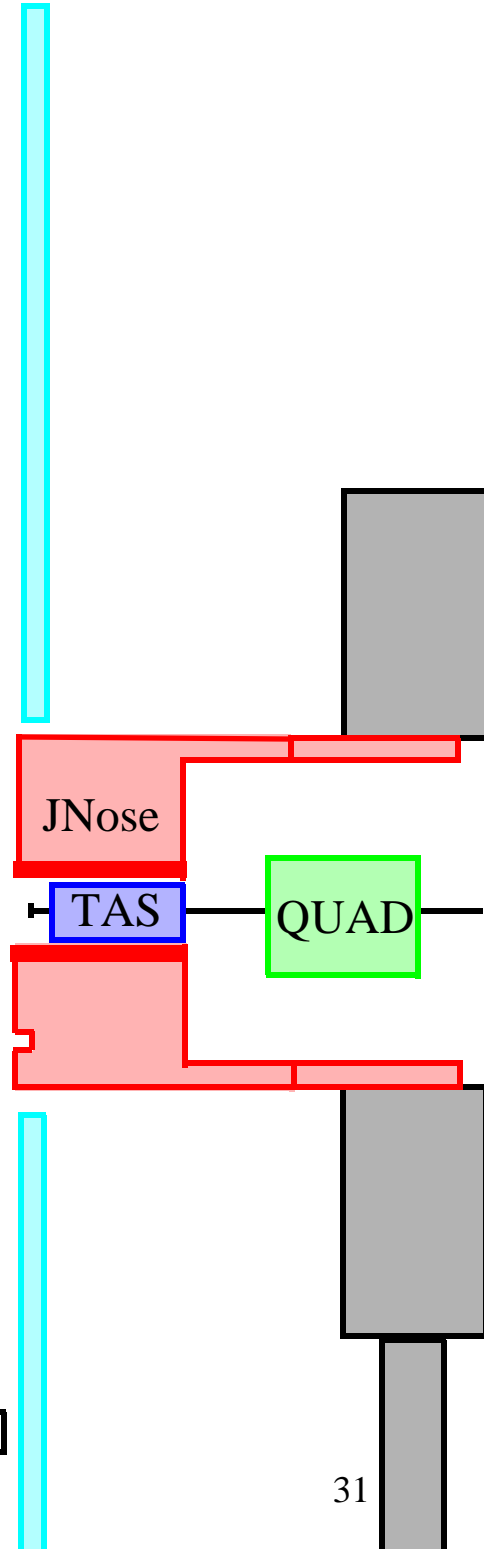
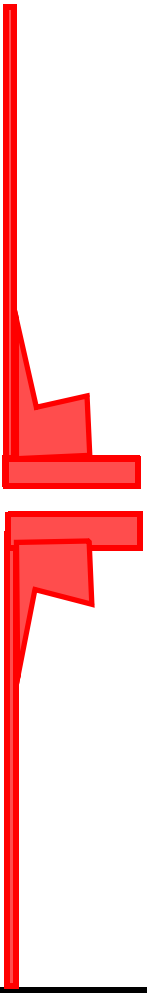
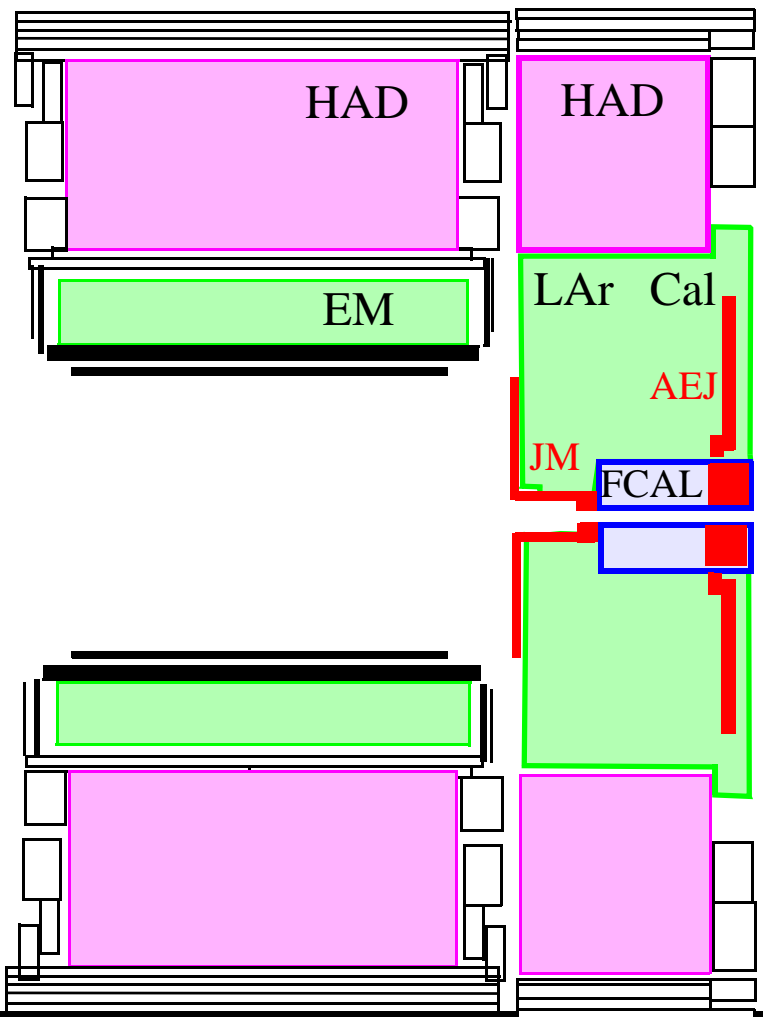

ACCESS

Rails

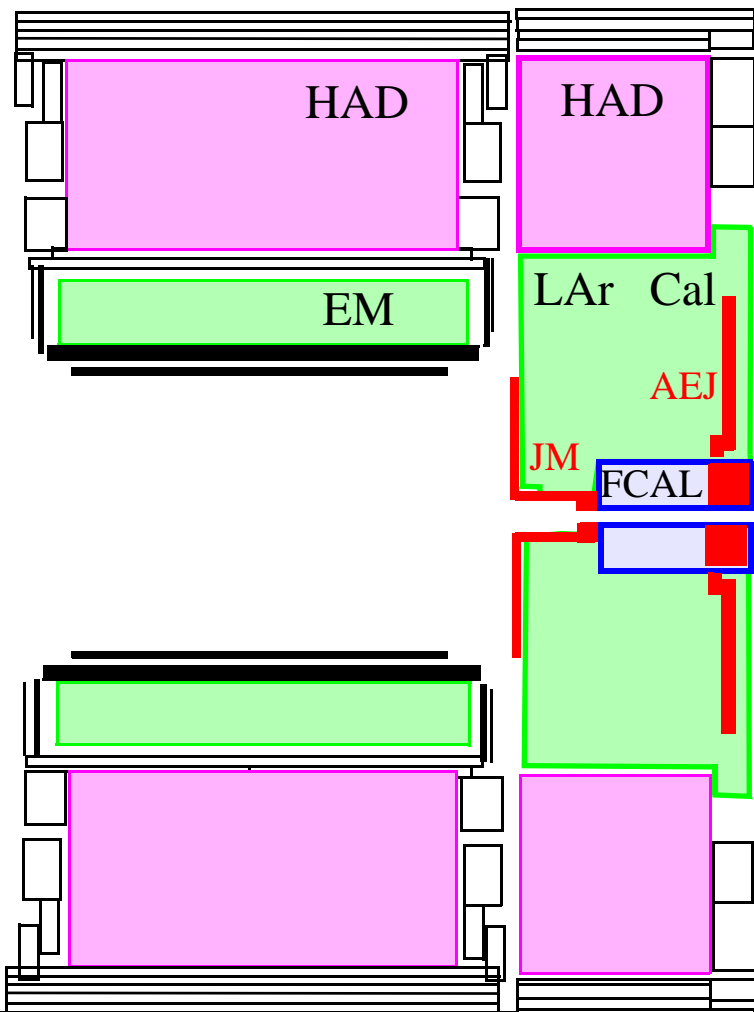

ACCESS

Rails

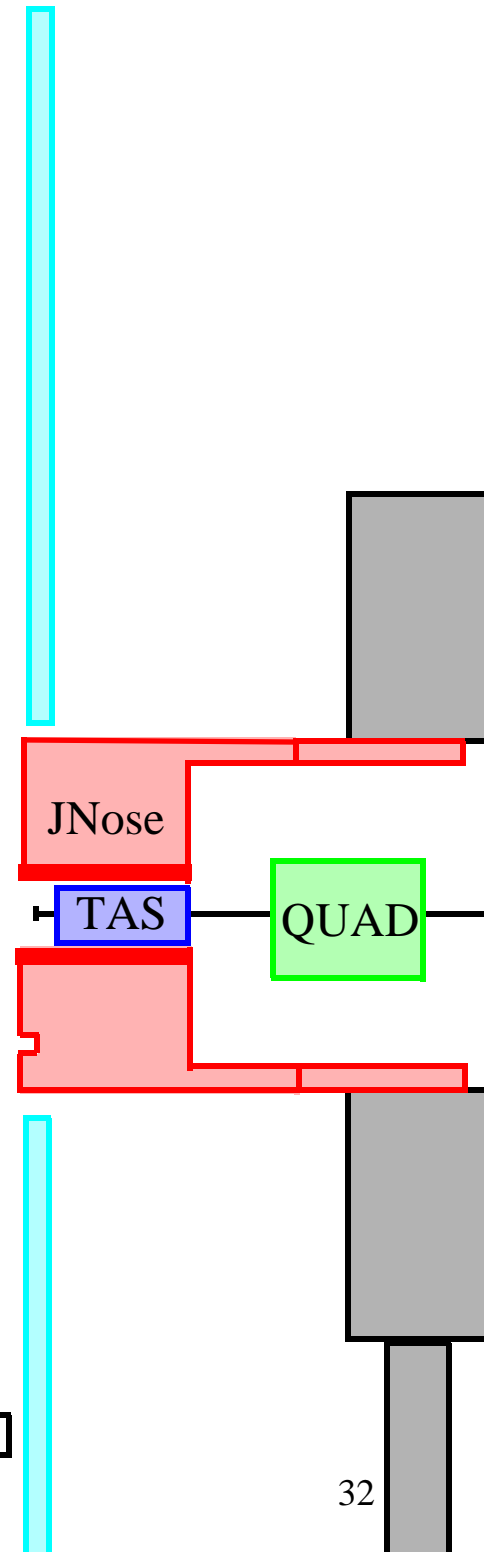

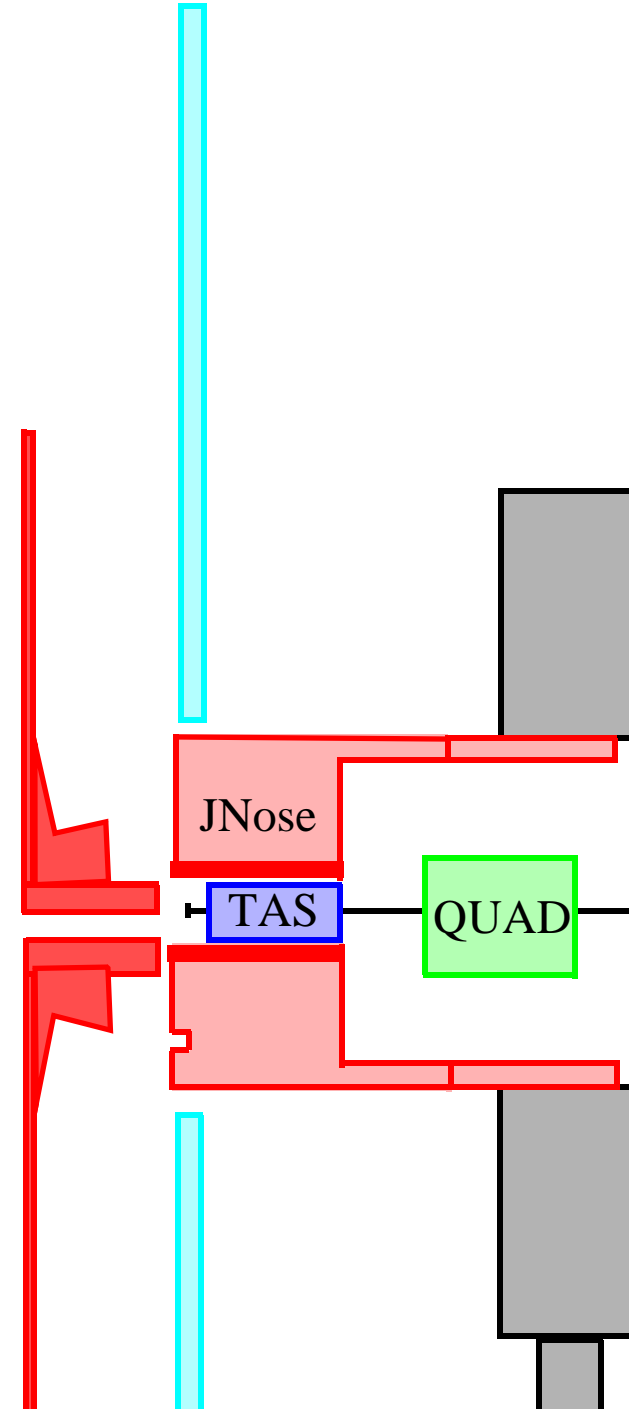
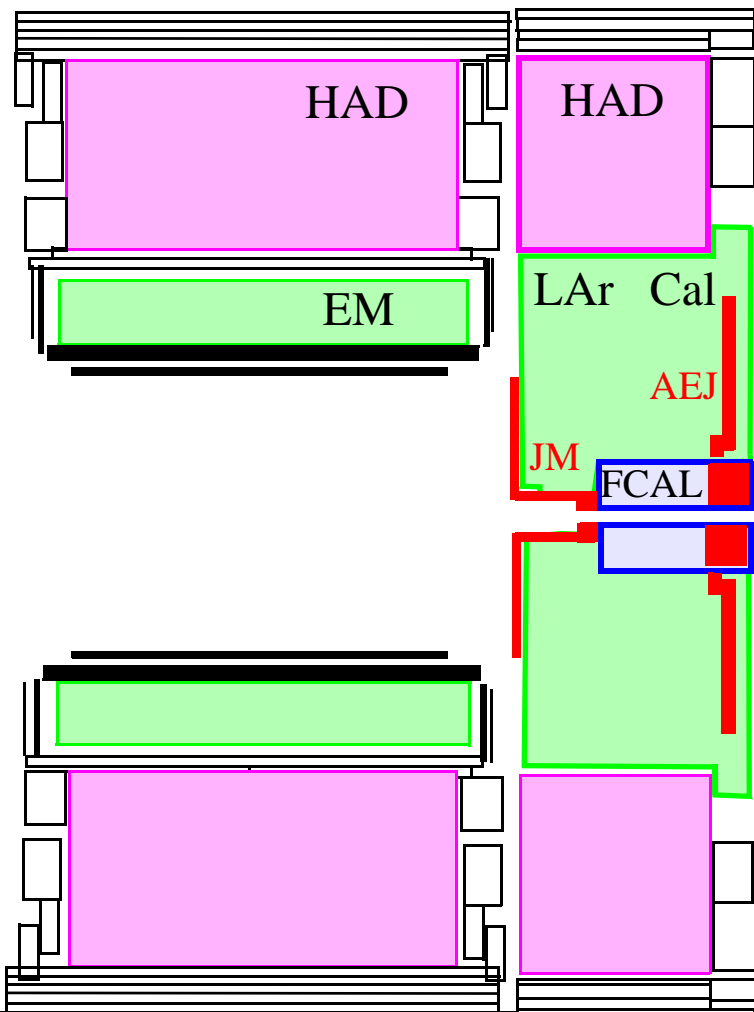

Rails

ACCESS

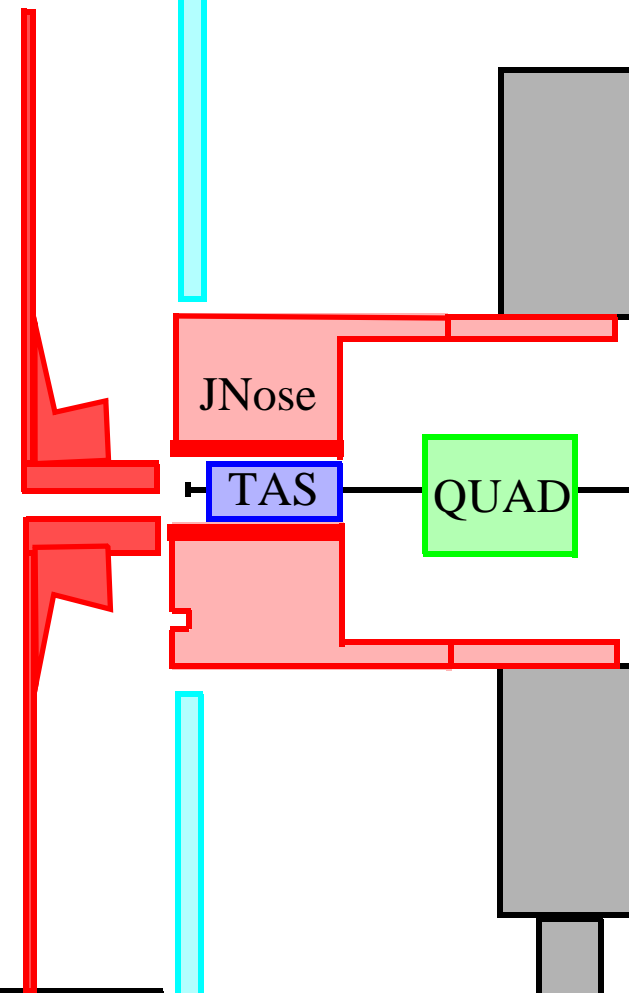
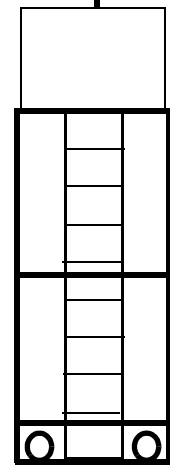
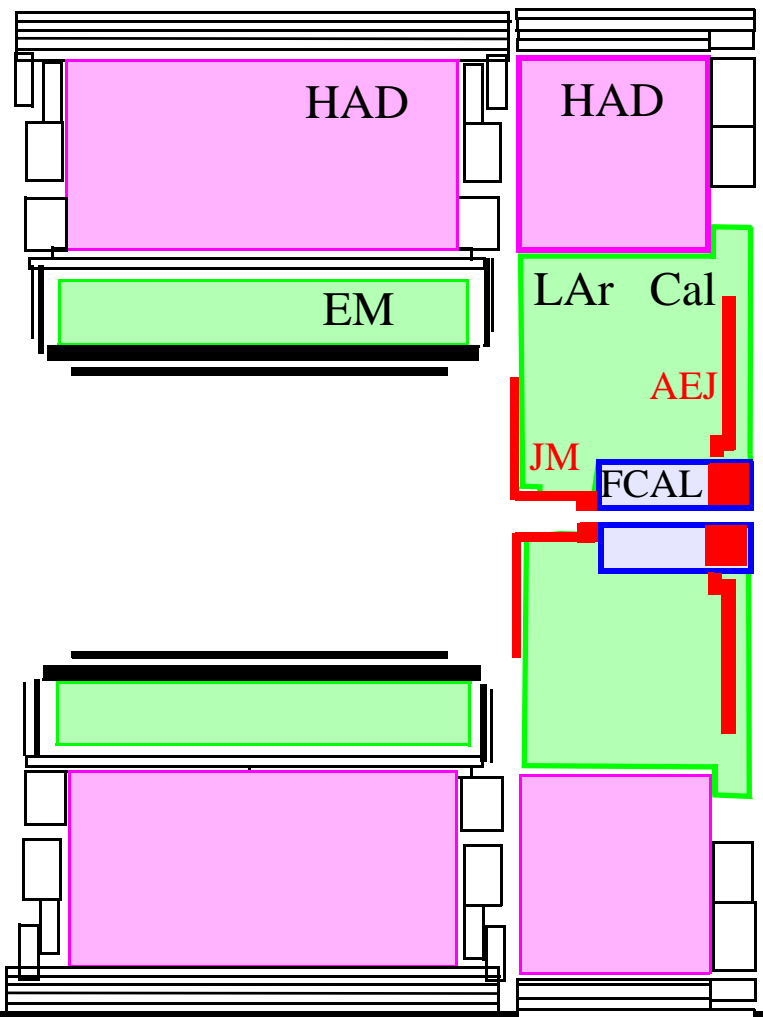

ACCESS

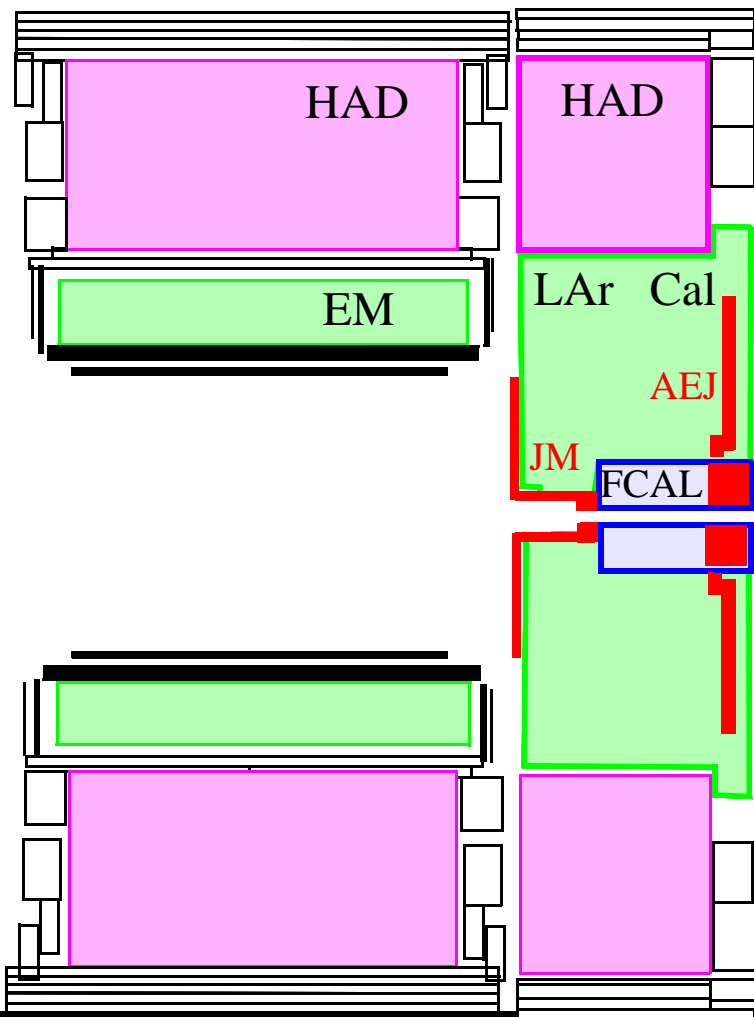

Rails

ACCESS

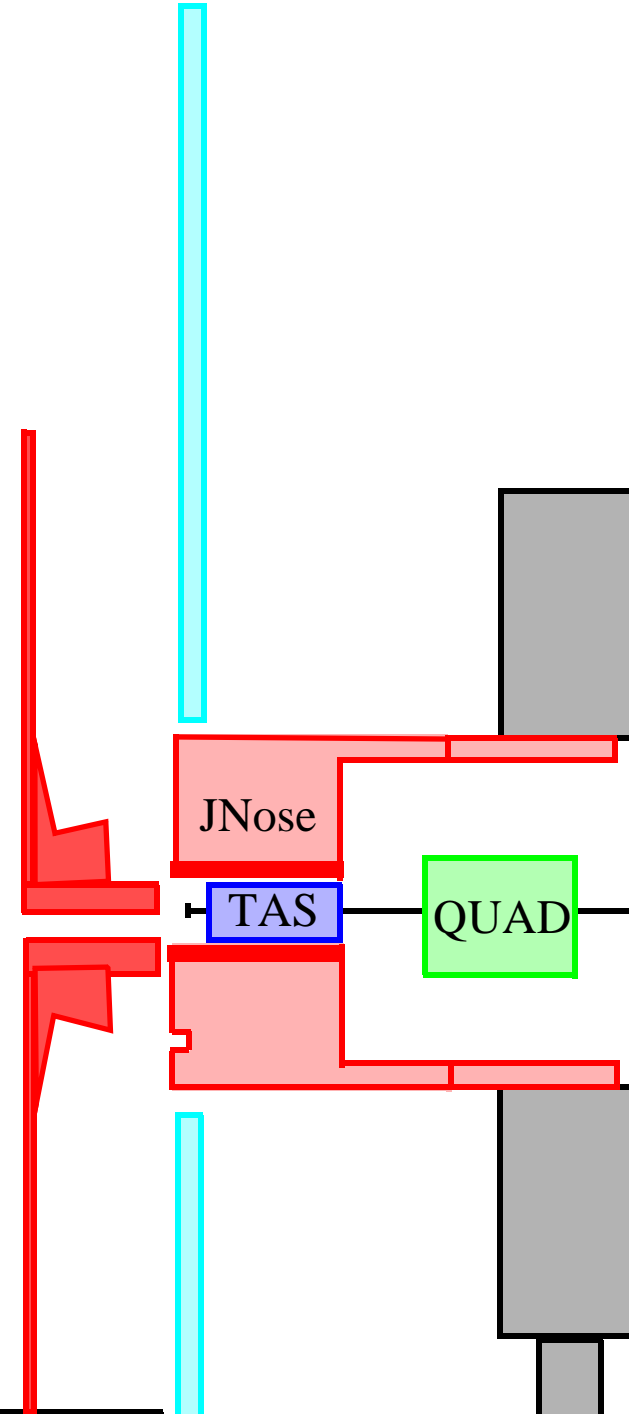
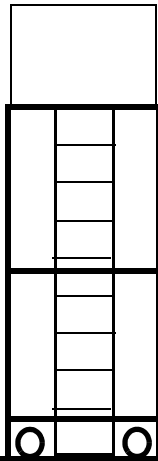

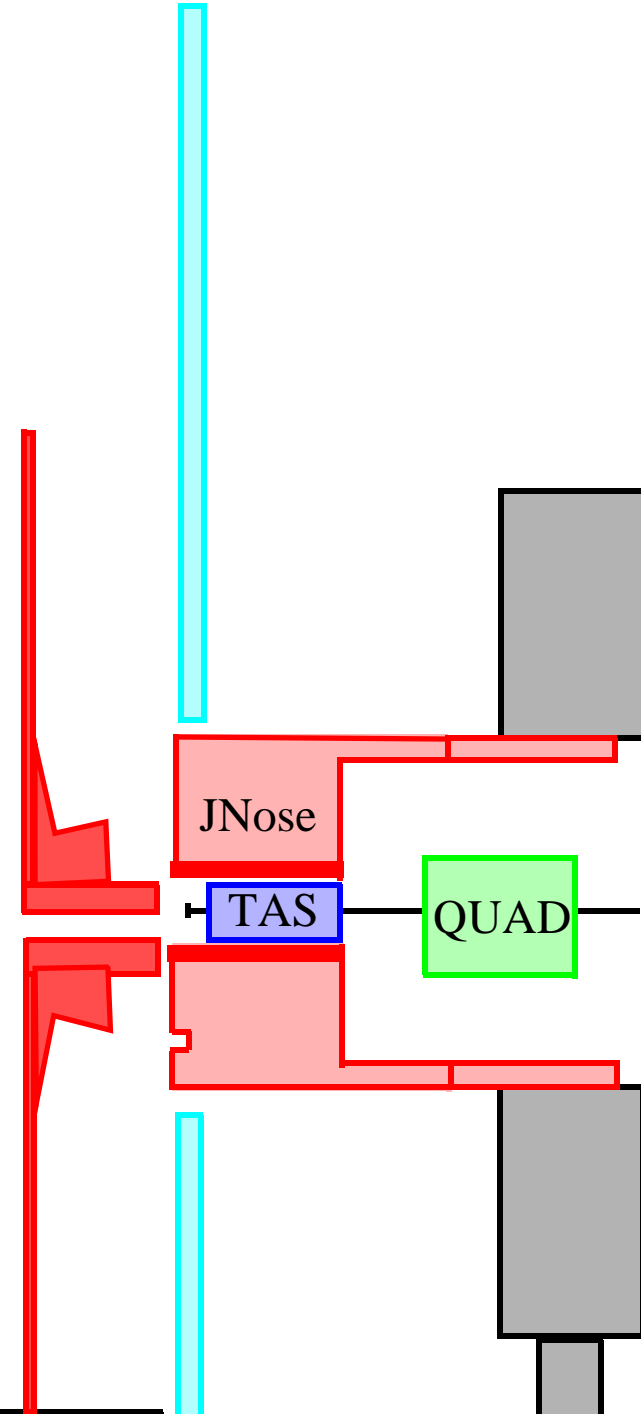
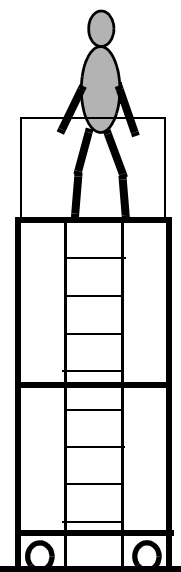
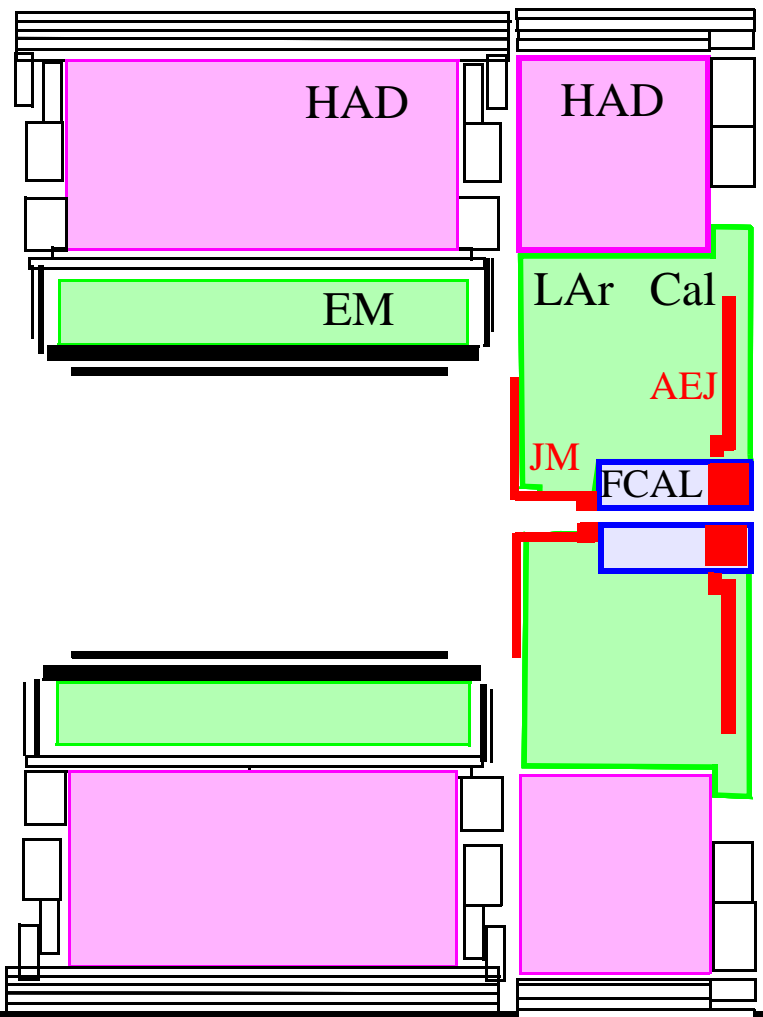

ACCESS

Rails

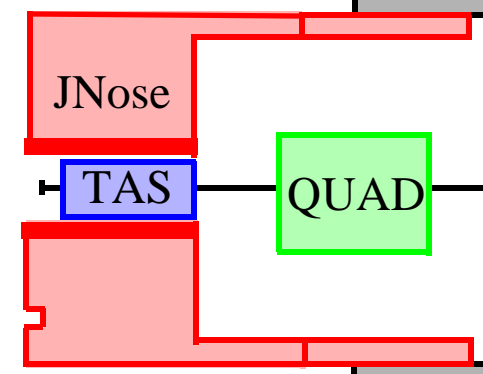
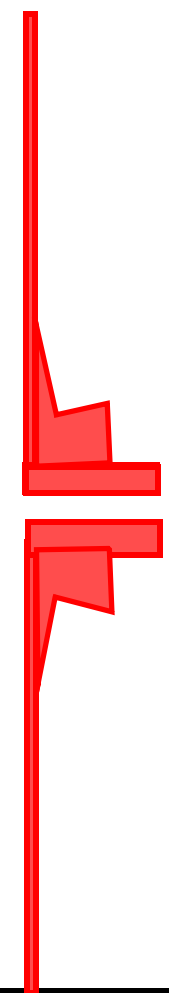
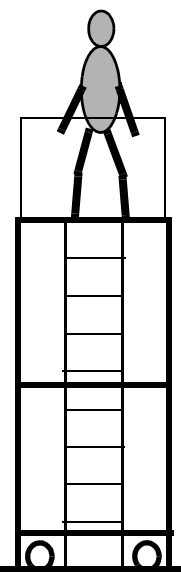
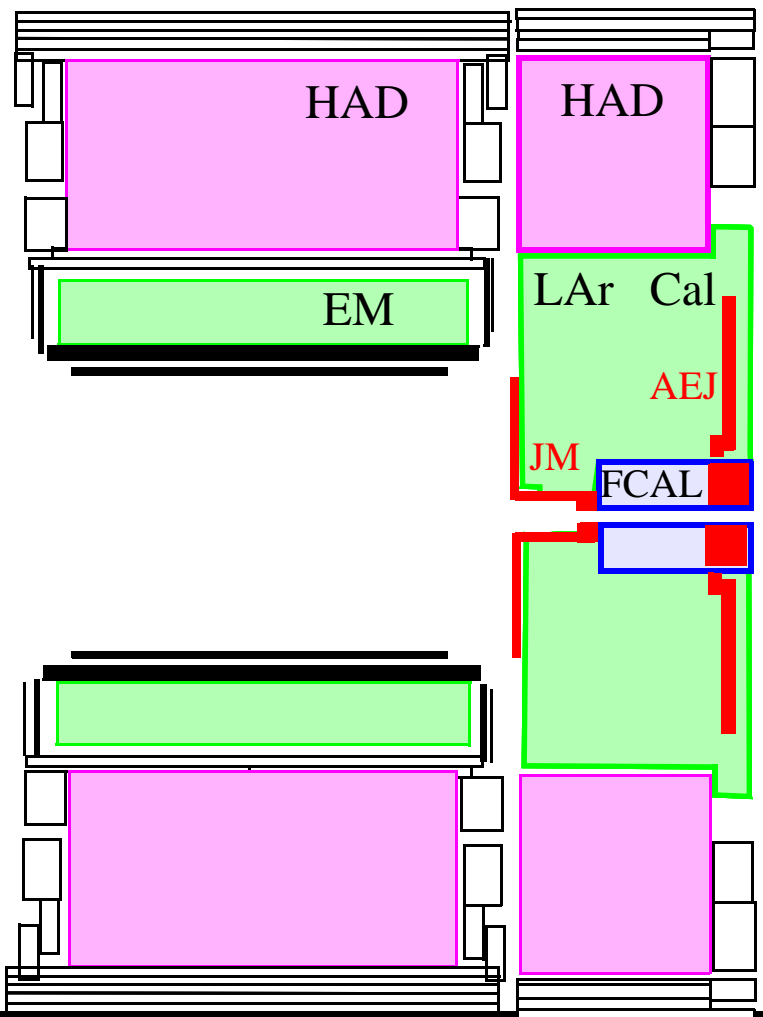

ACCESS

Rails

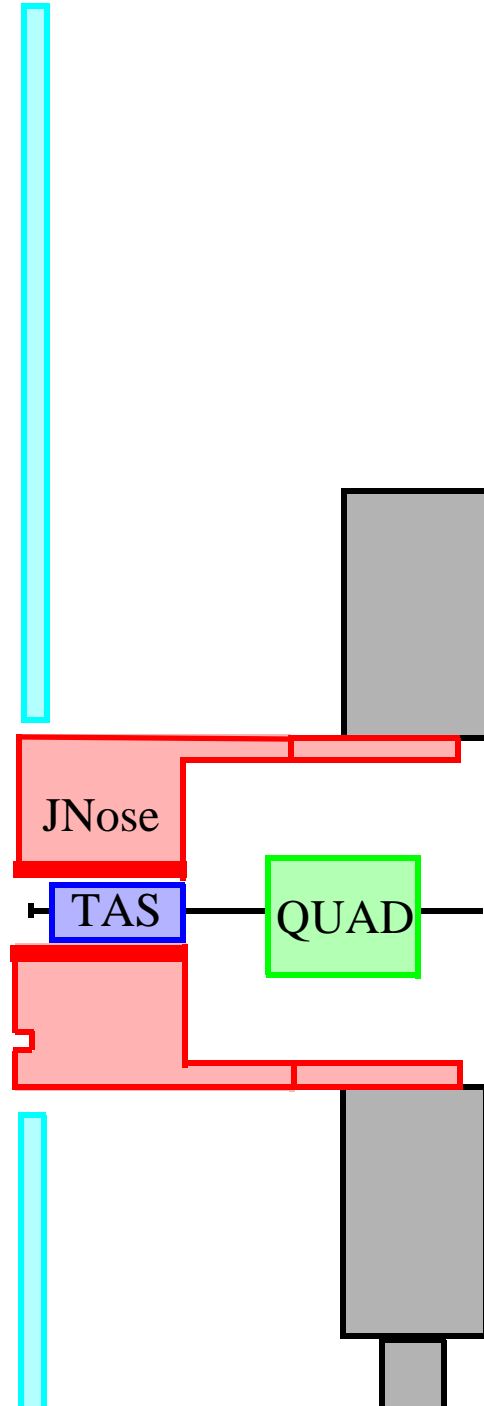
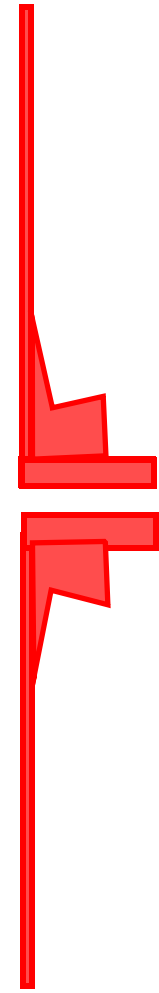
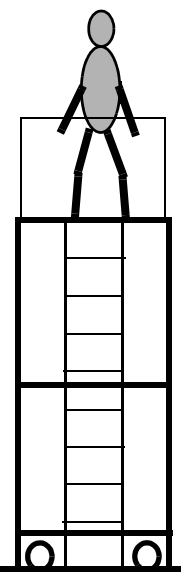
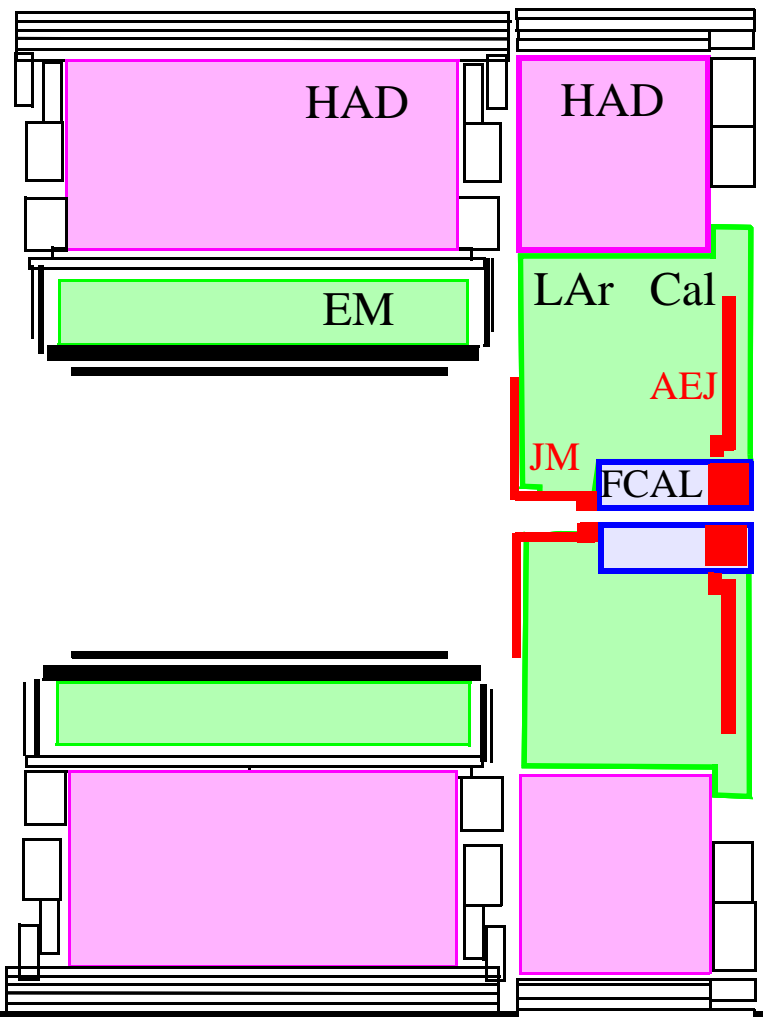

Rails

ACCESS

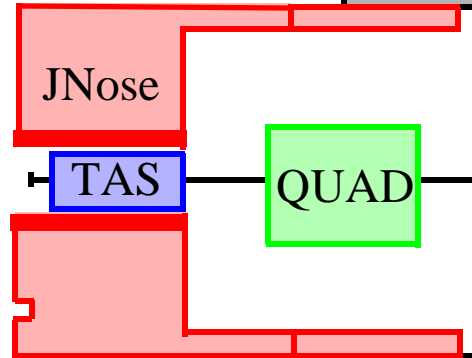
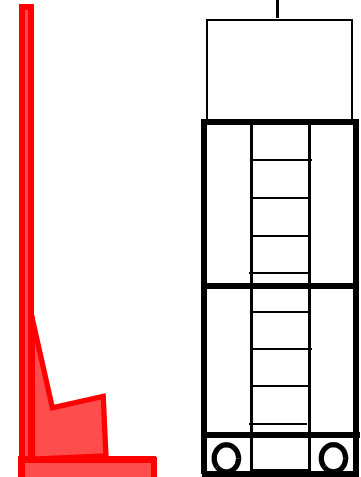
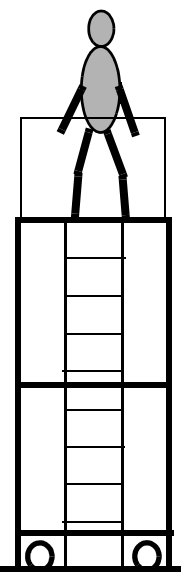
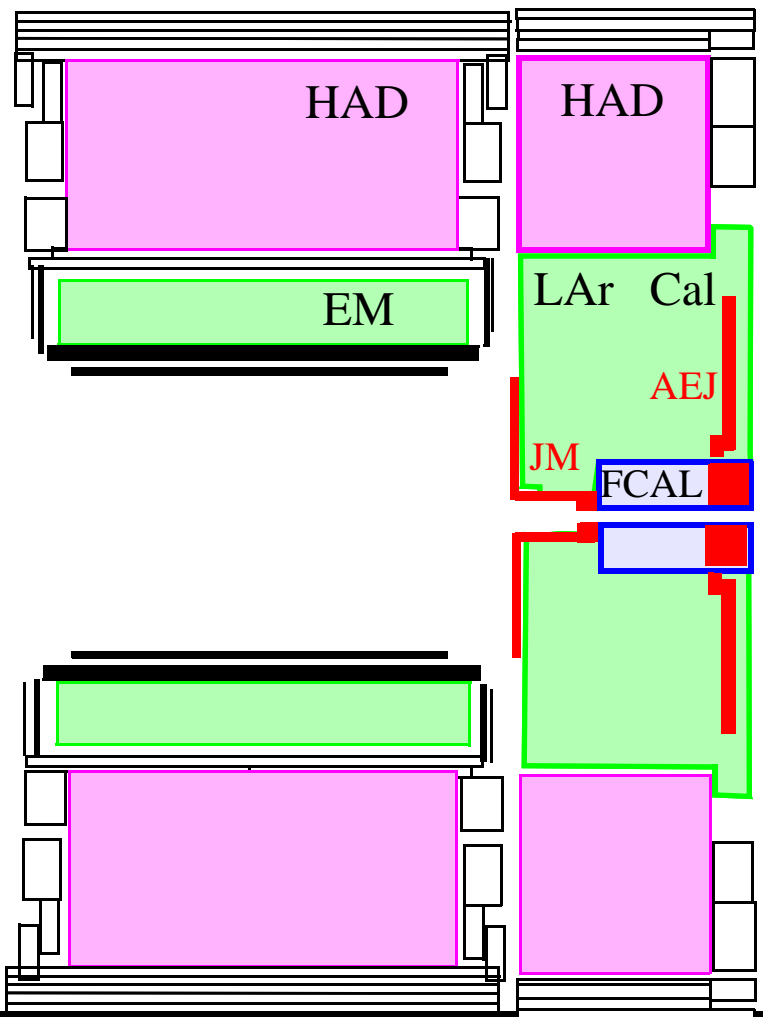

ACCESS

Rails

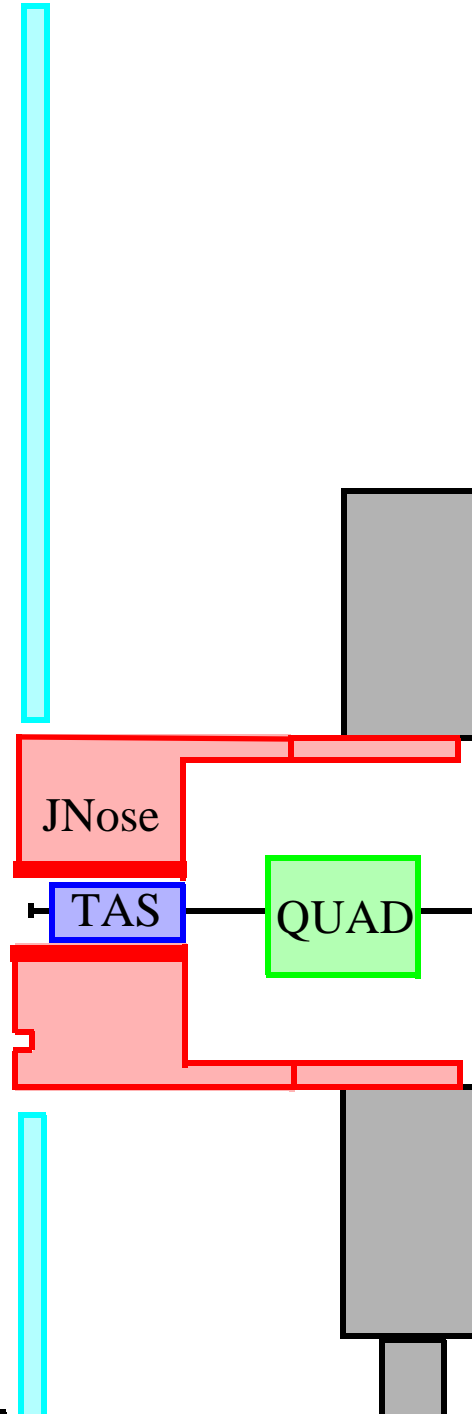
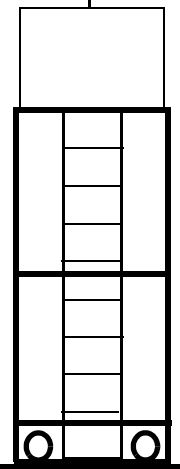
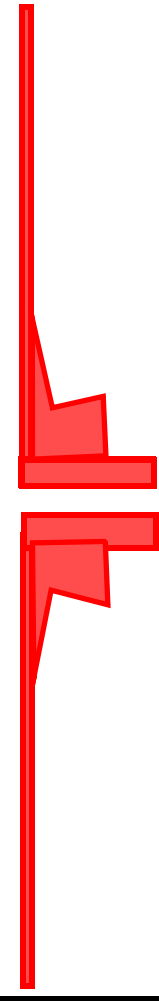
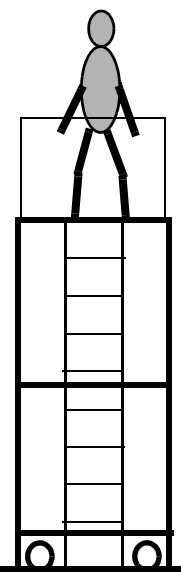
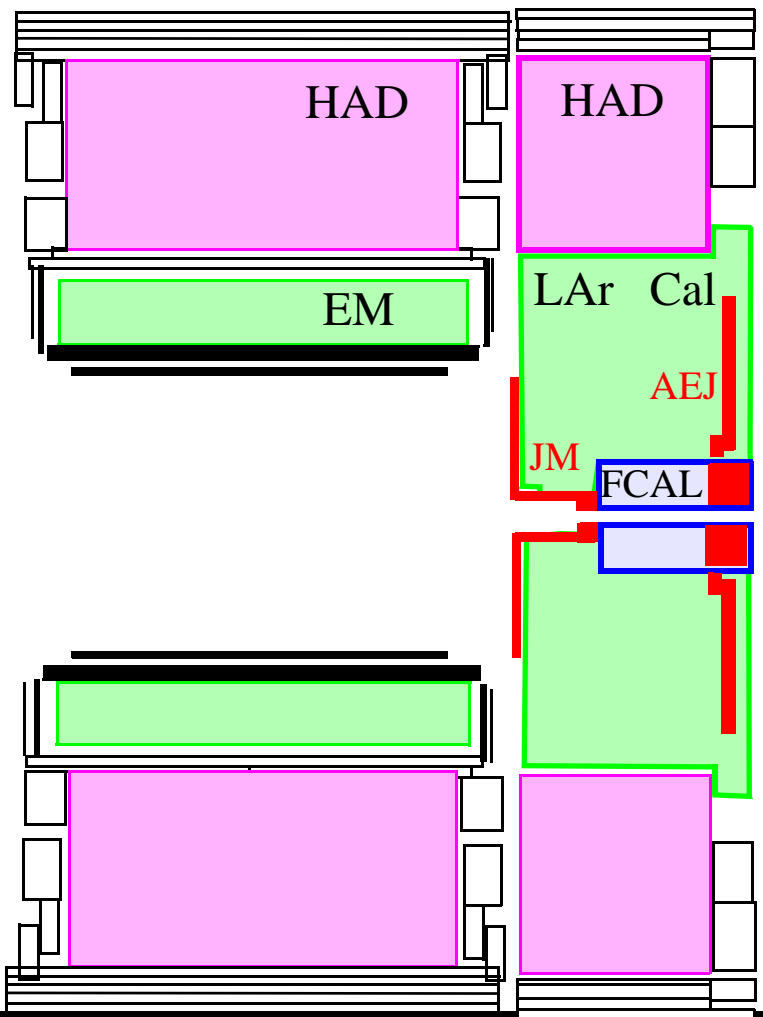

ACCESS

Rails

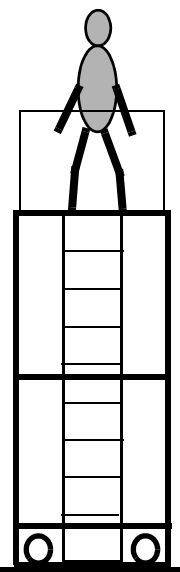
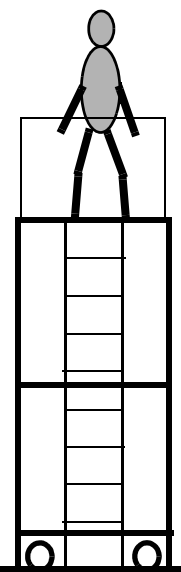
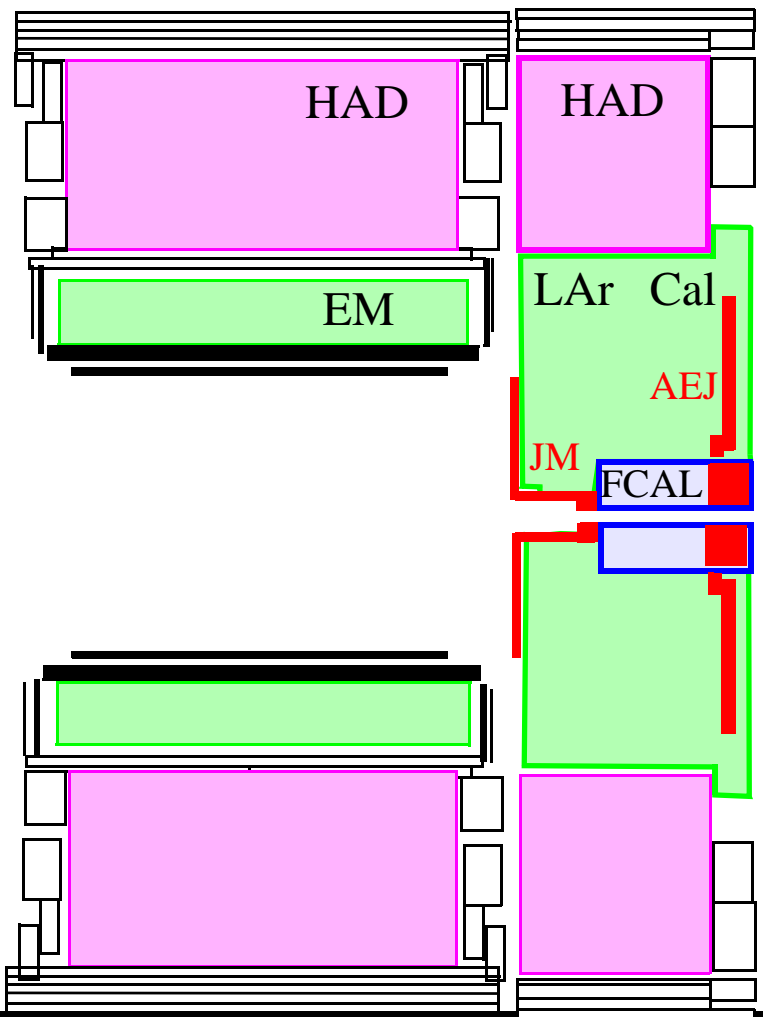

Rails

ACCESS

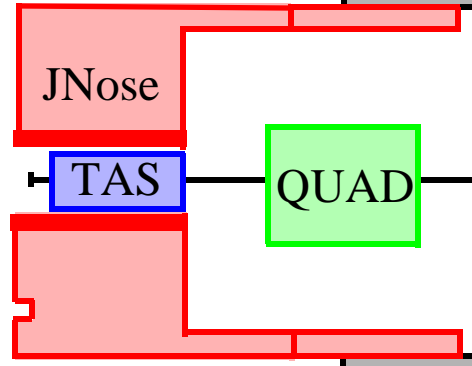
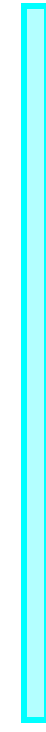
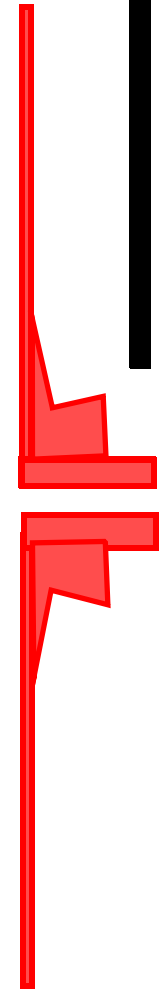
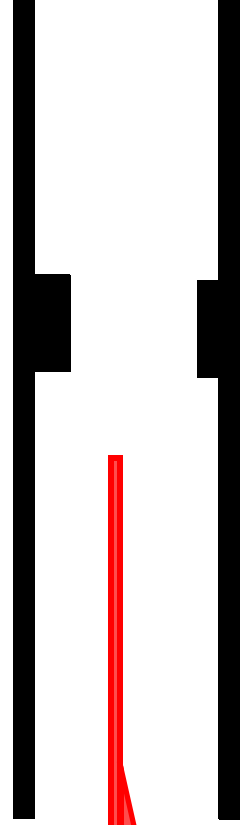

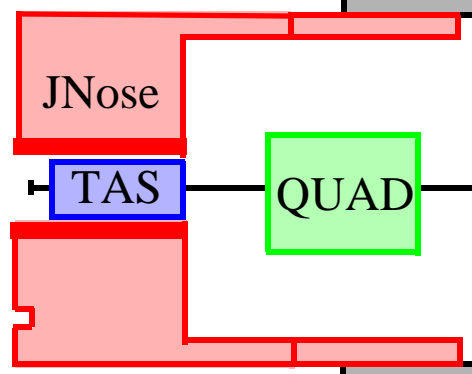
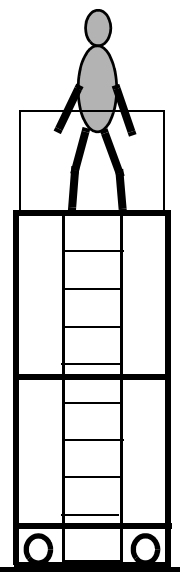
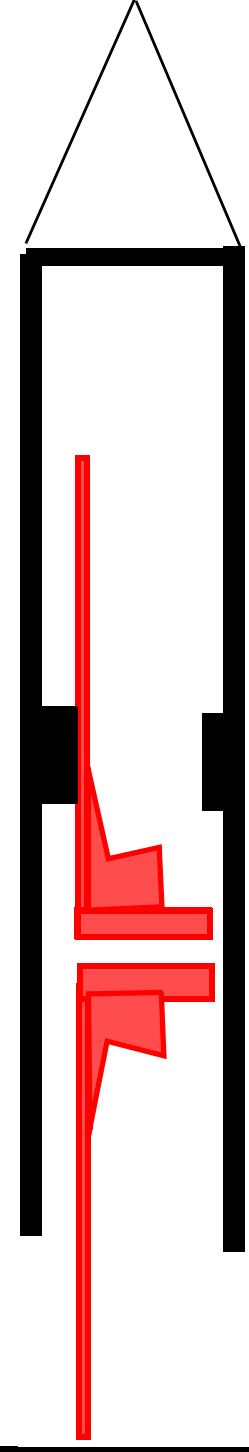
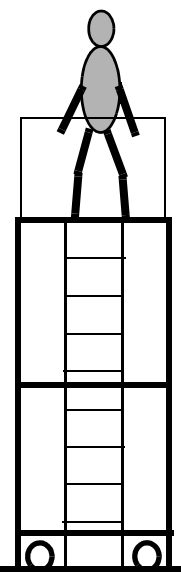
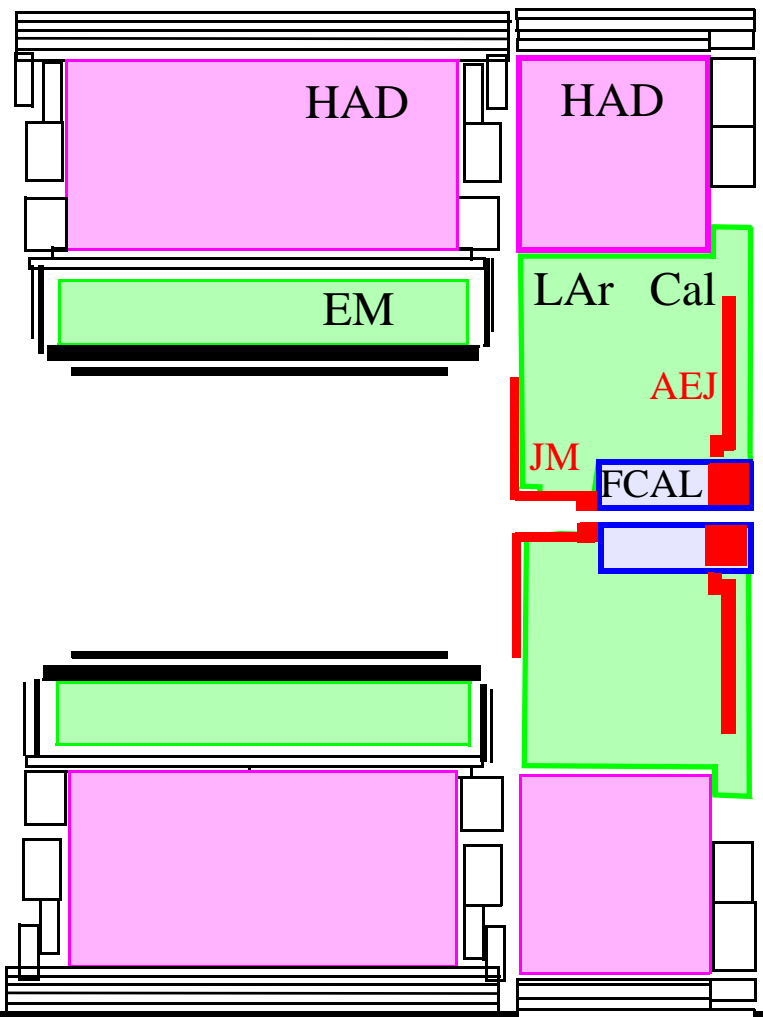

Rails

ACCESS

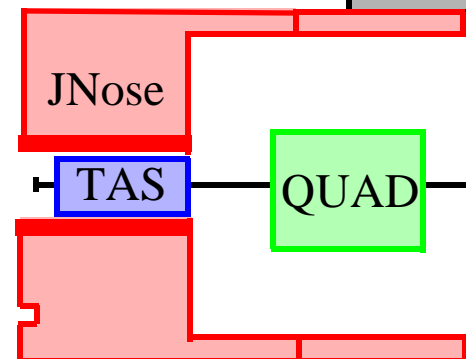
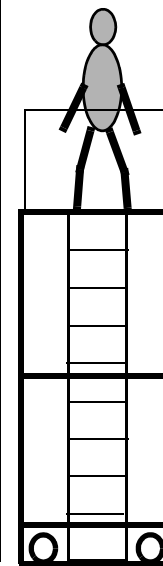
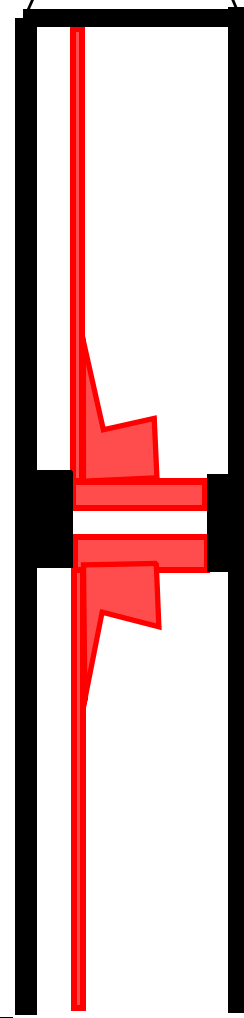
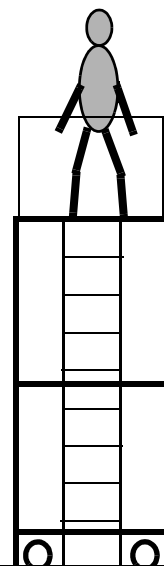
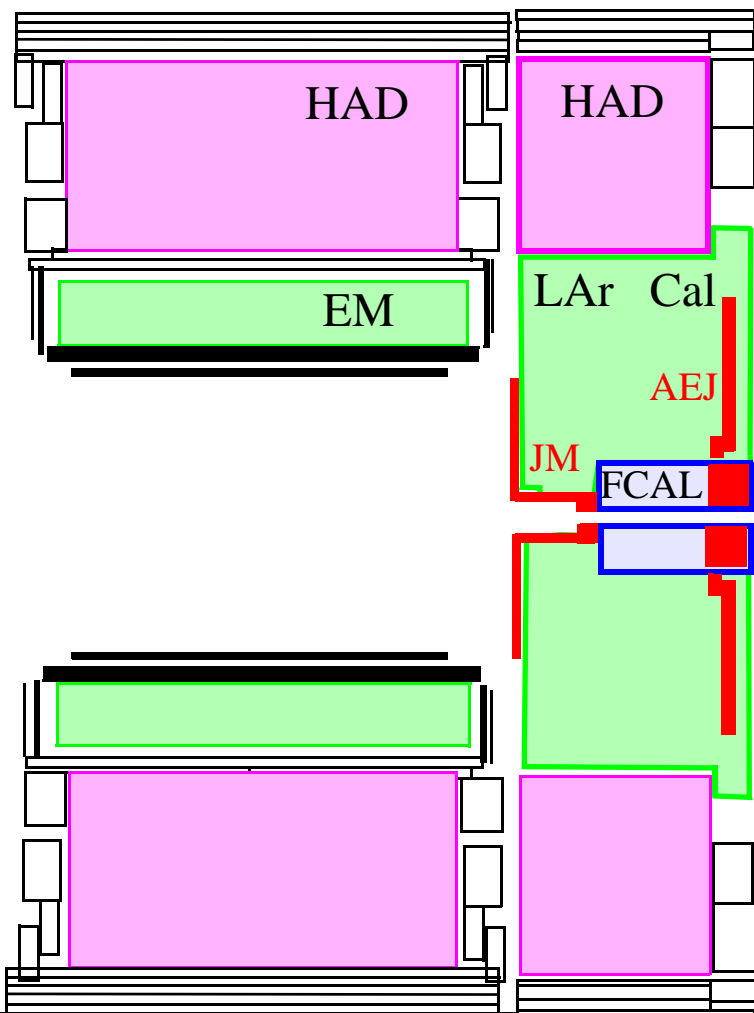

Rails

ACCESS

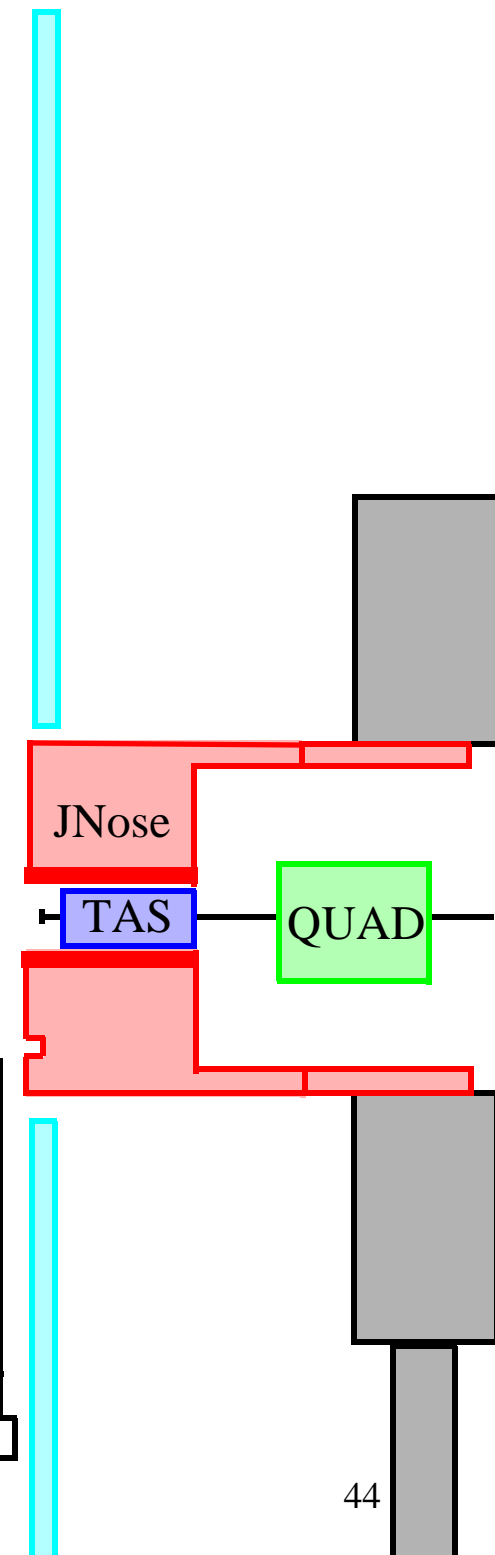
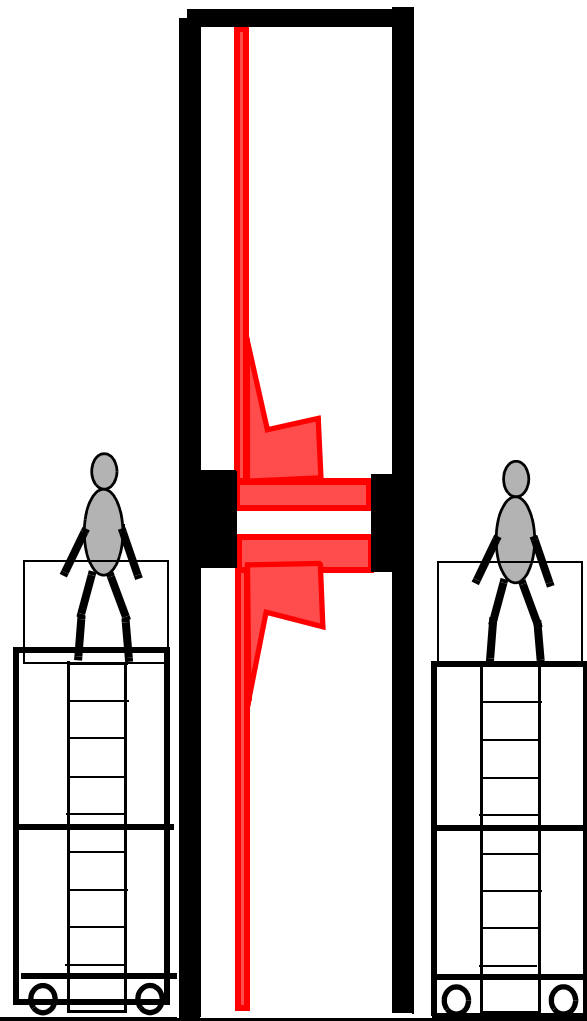
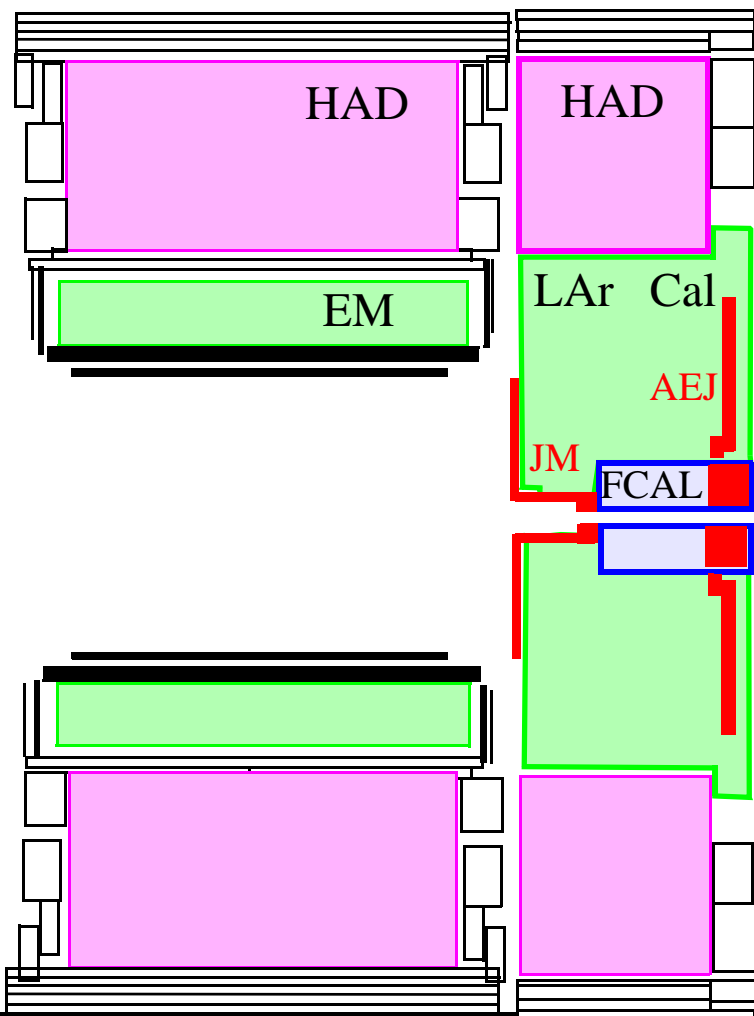

ACCESS

Rails

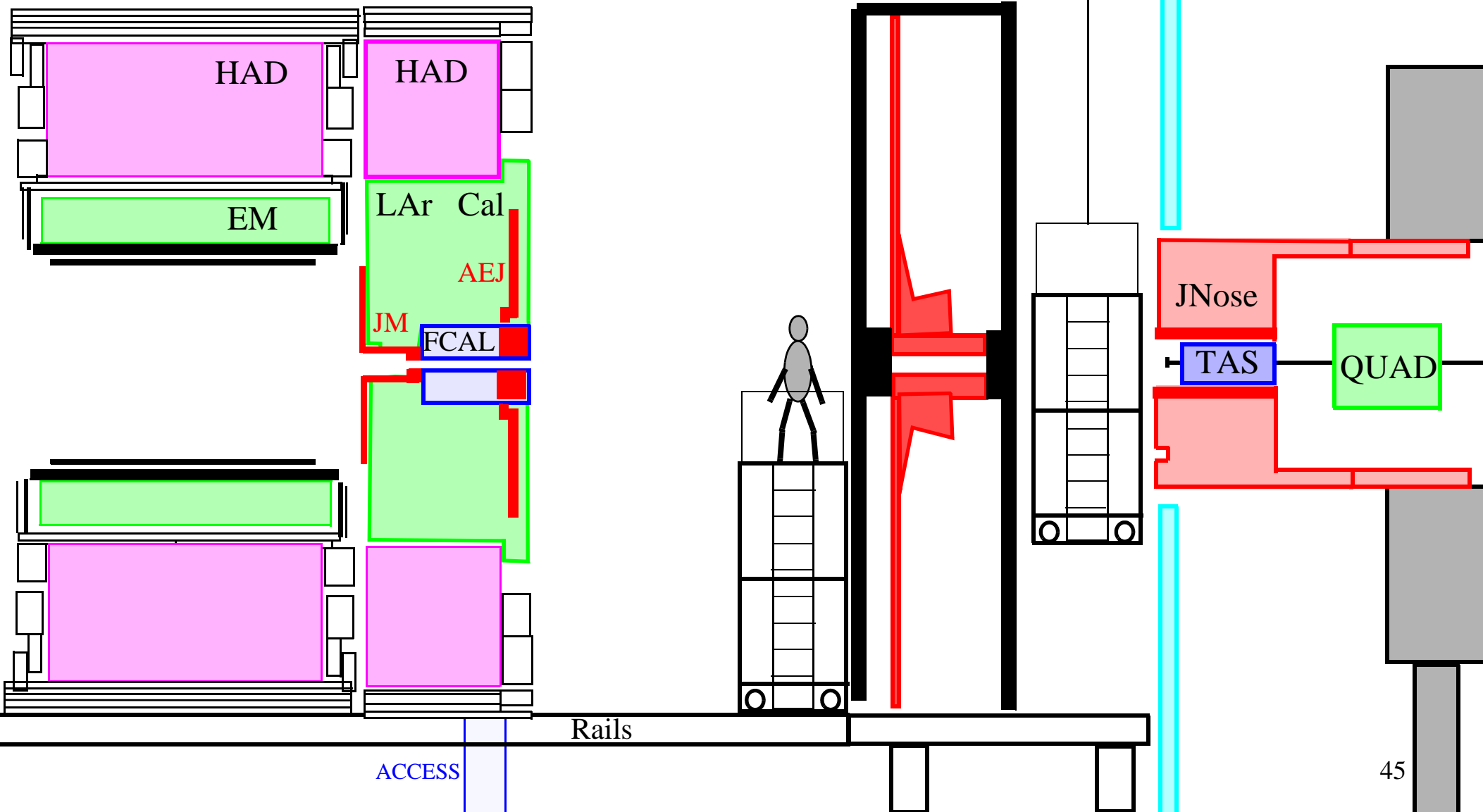

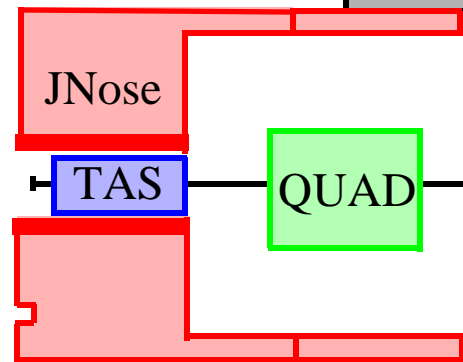
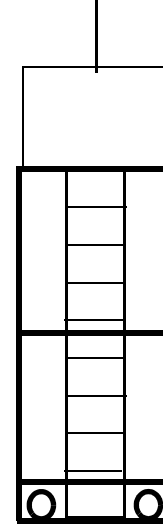
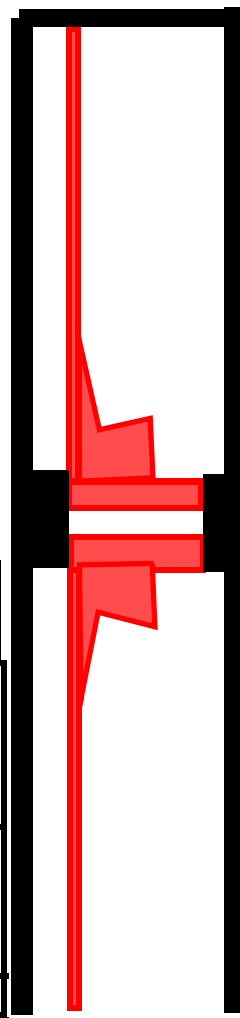
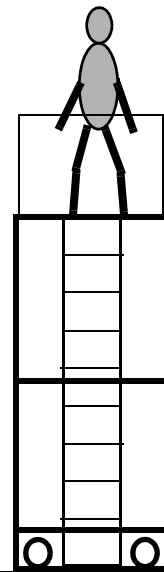
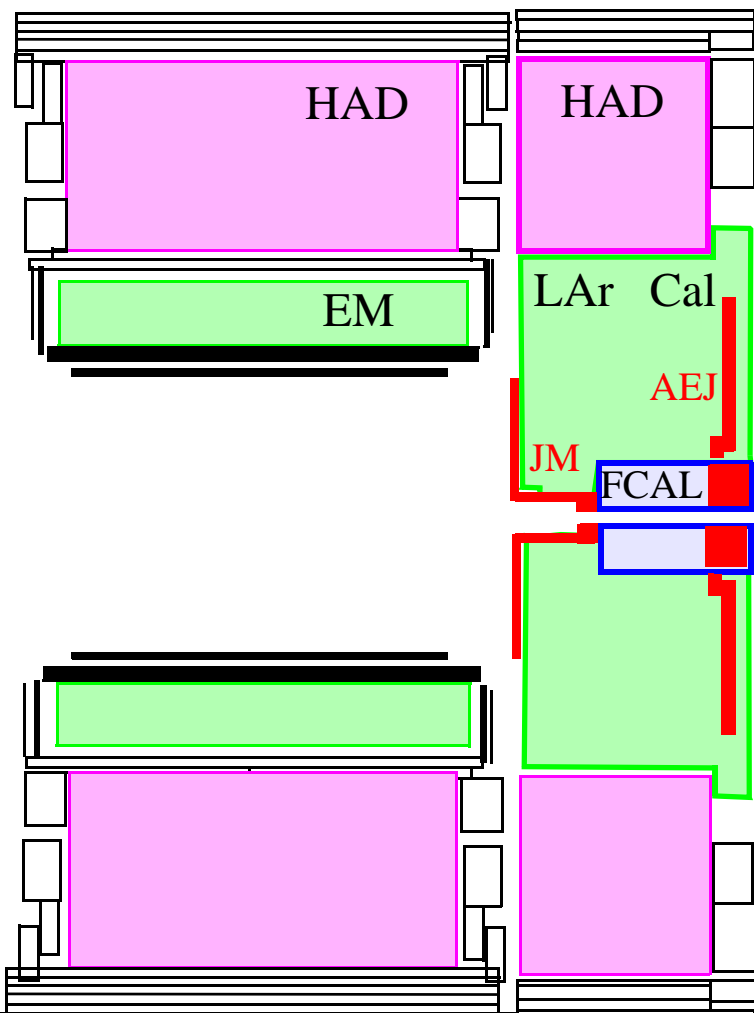

Rails

ACCESS

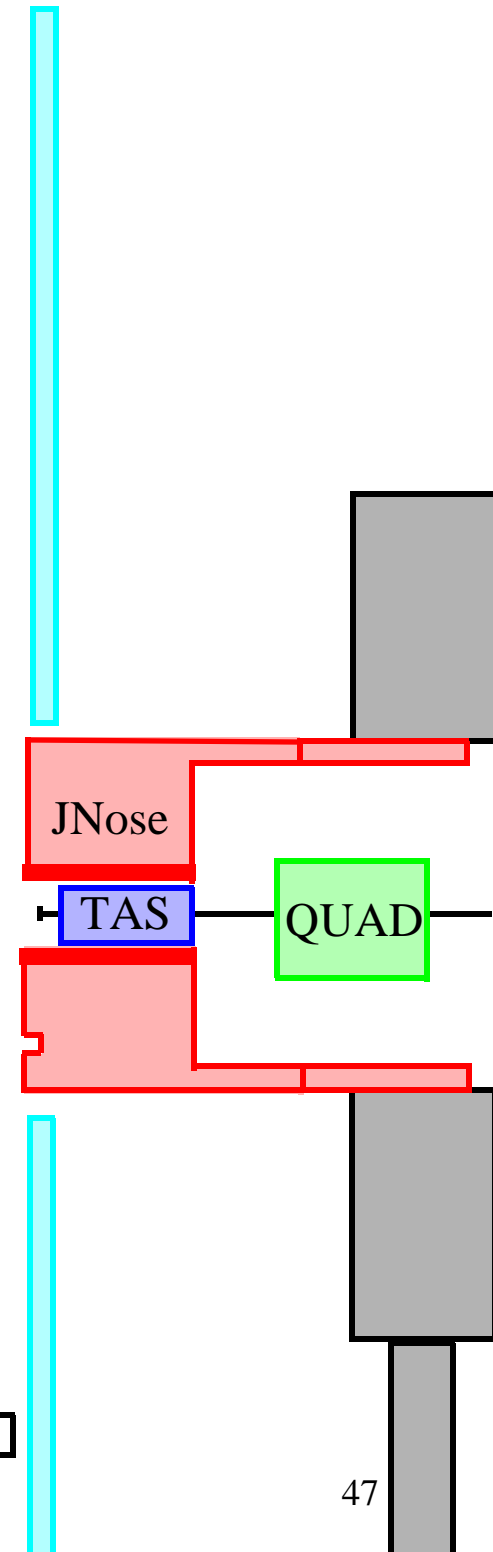
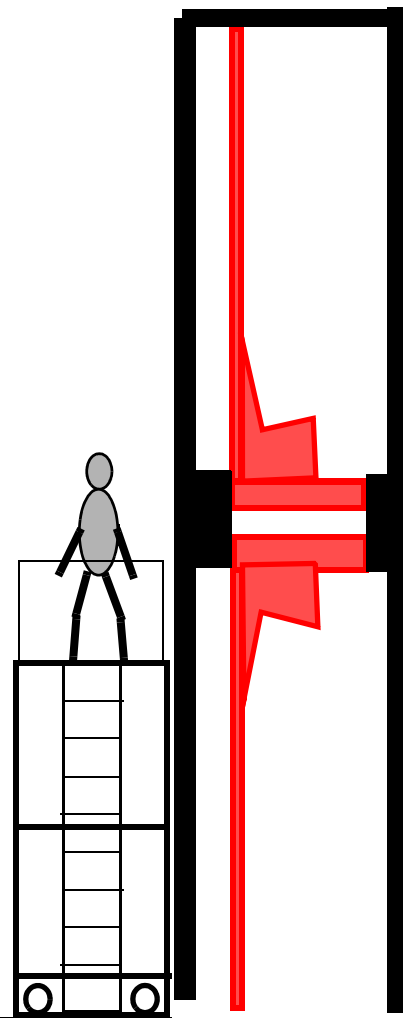
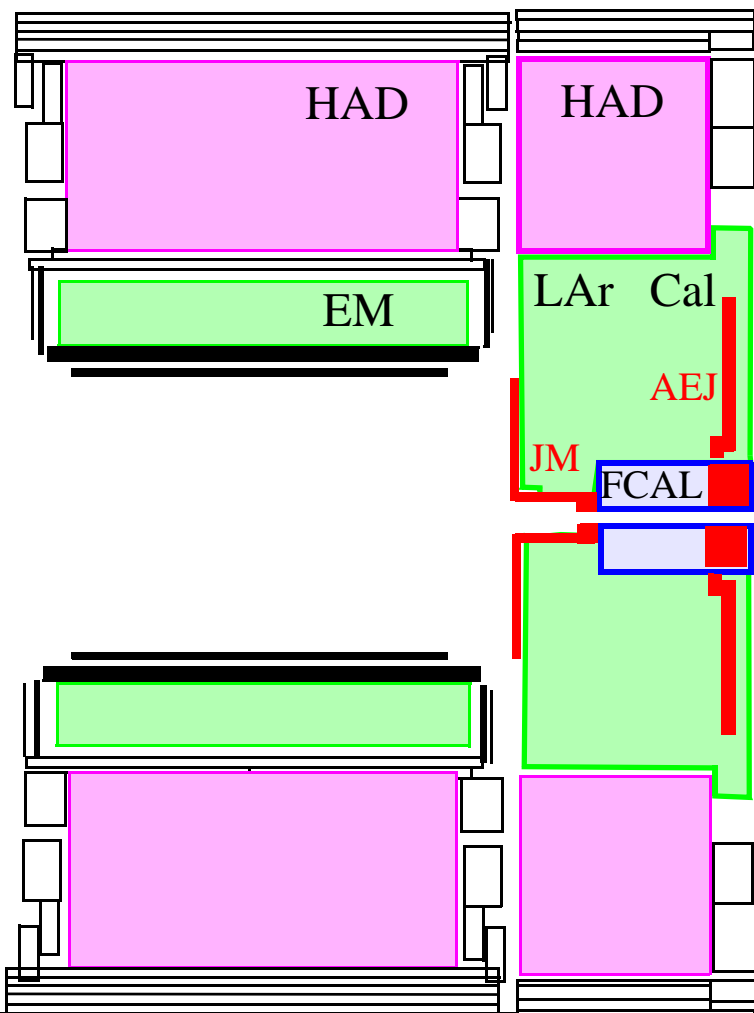

ACCESS

Rails

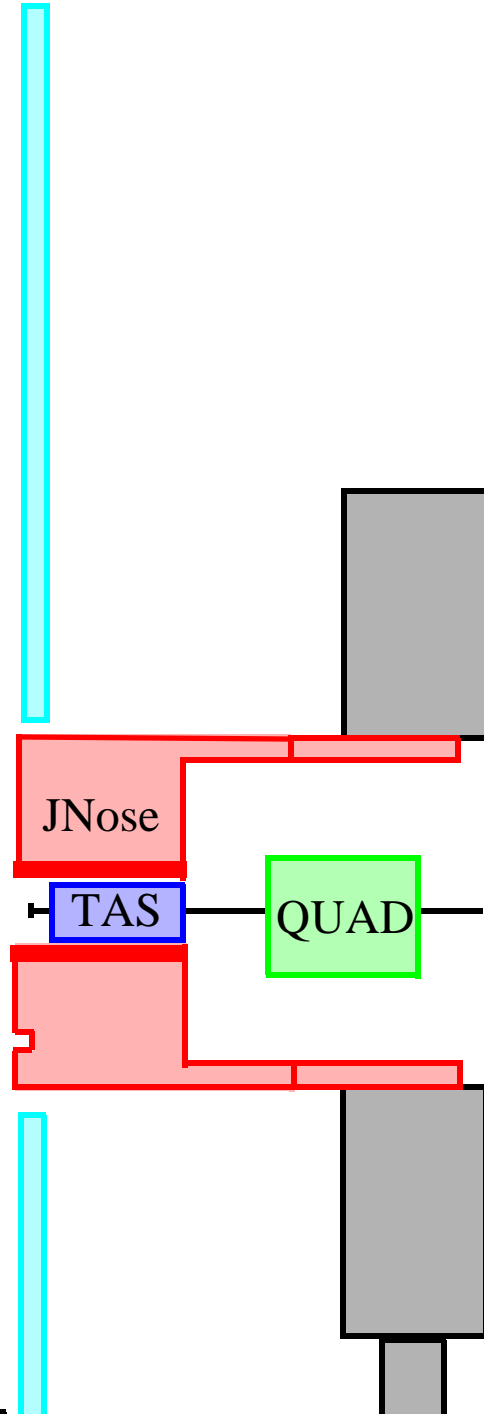
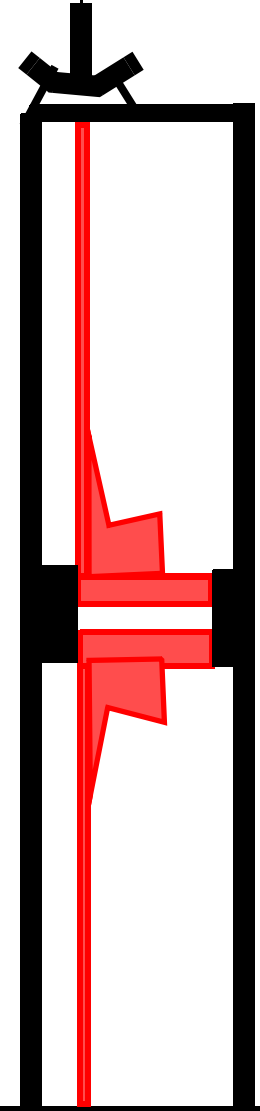
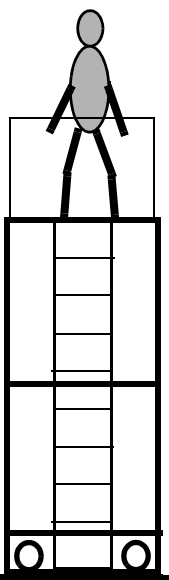
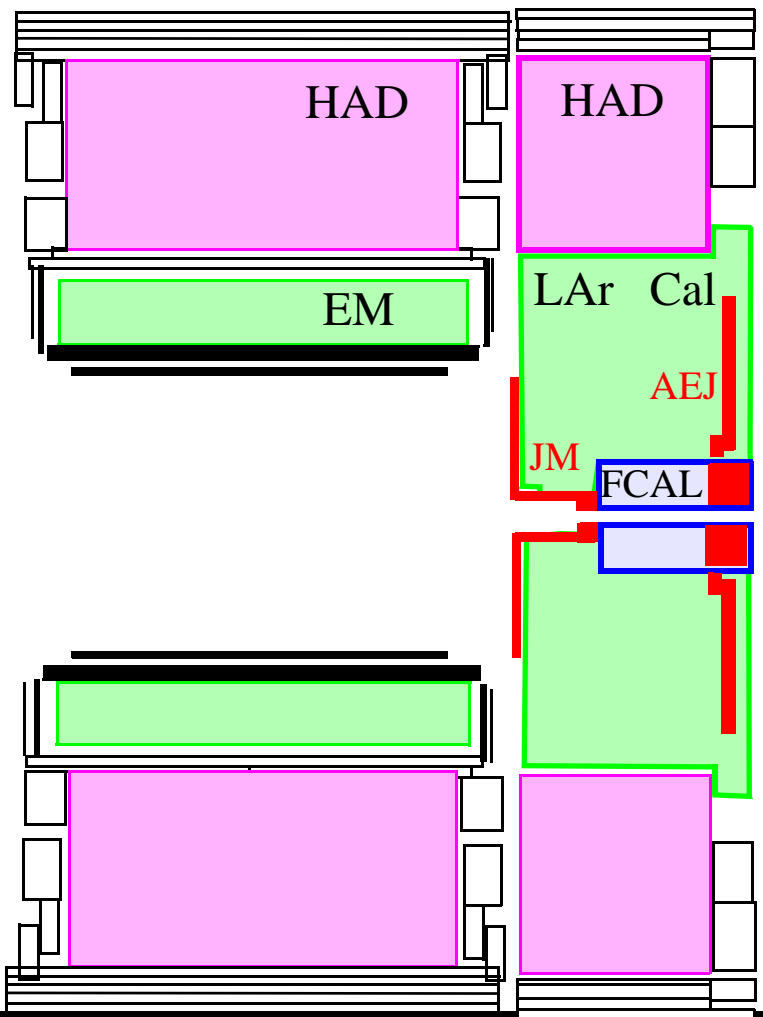

Rails

ACCESS

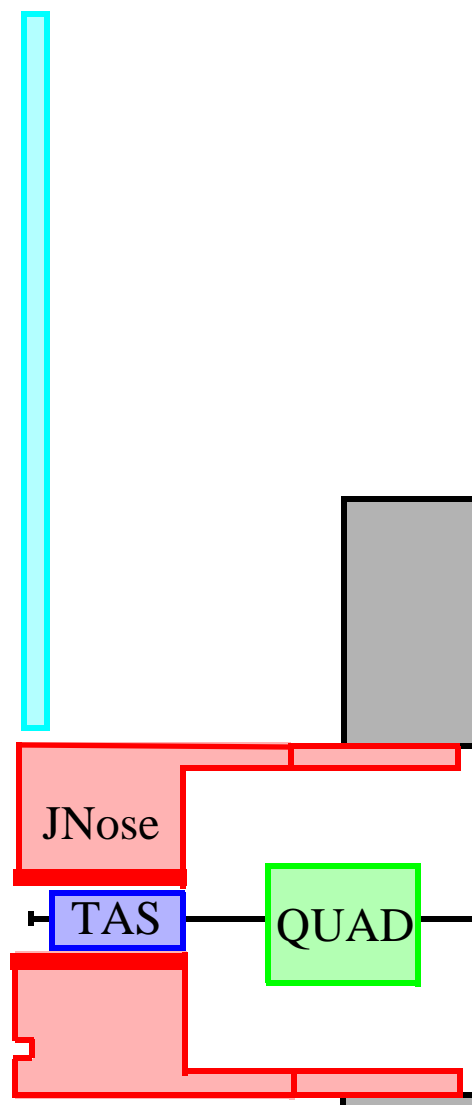
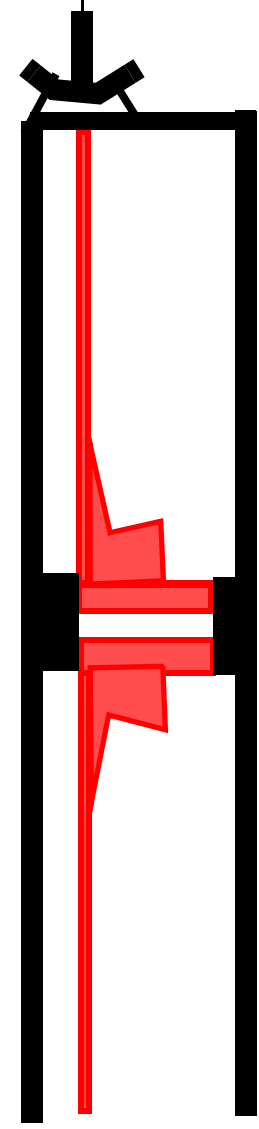
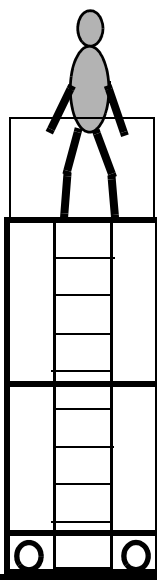
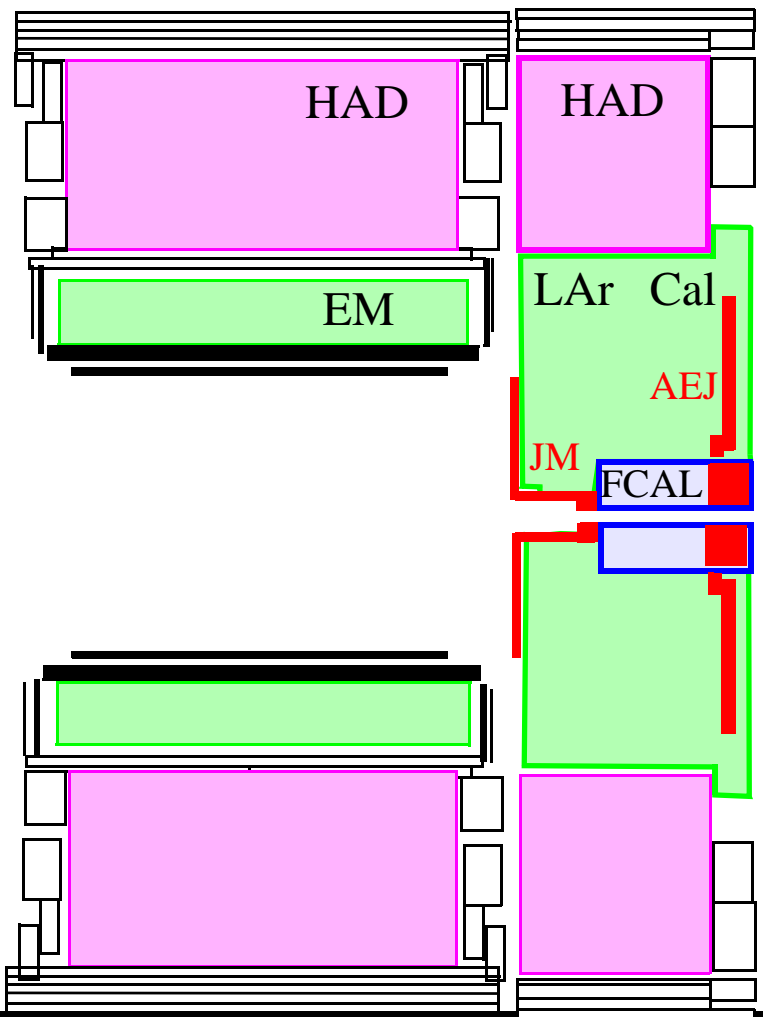

ACCESS

Rails

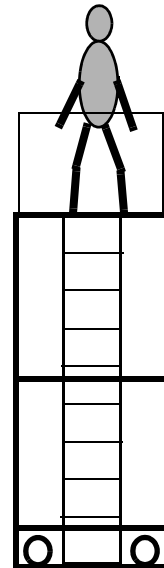
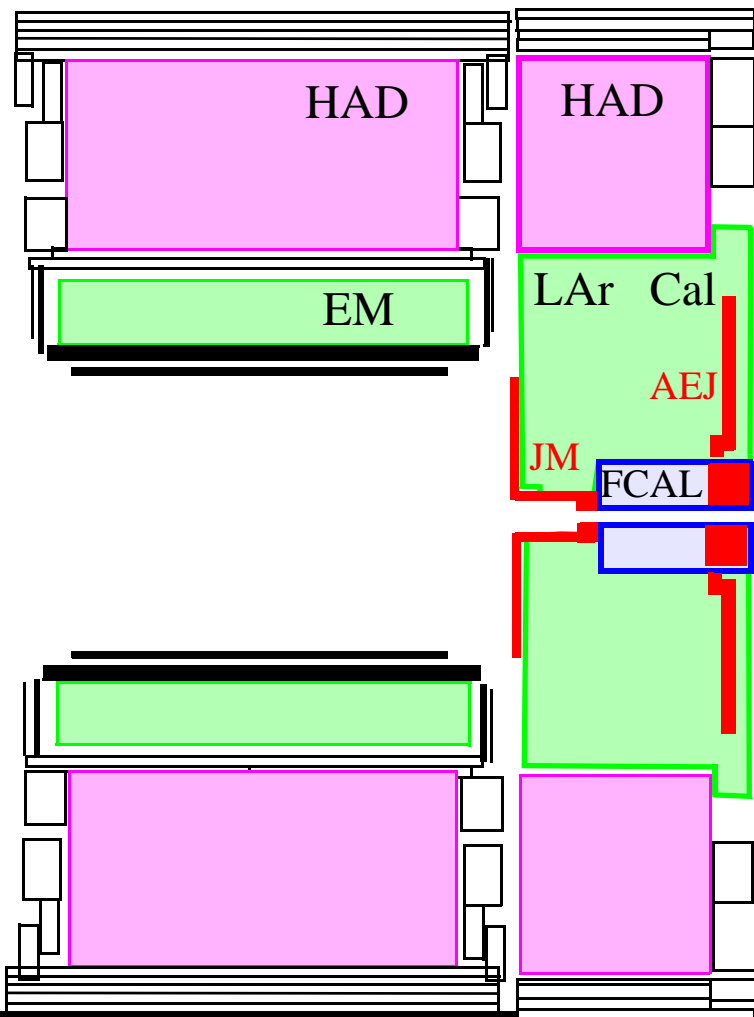

Rails

ACCESS

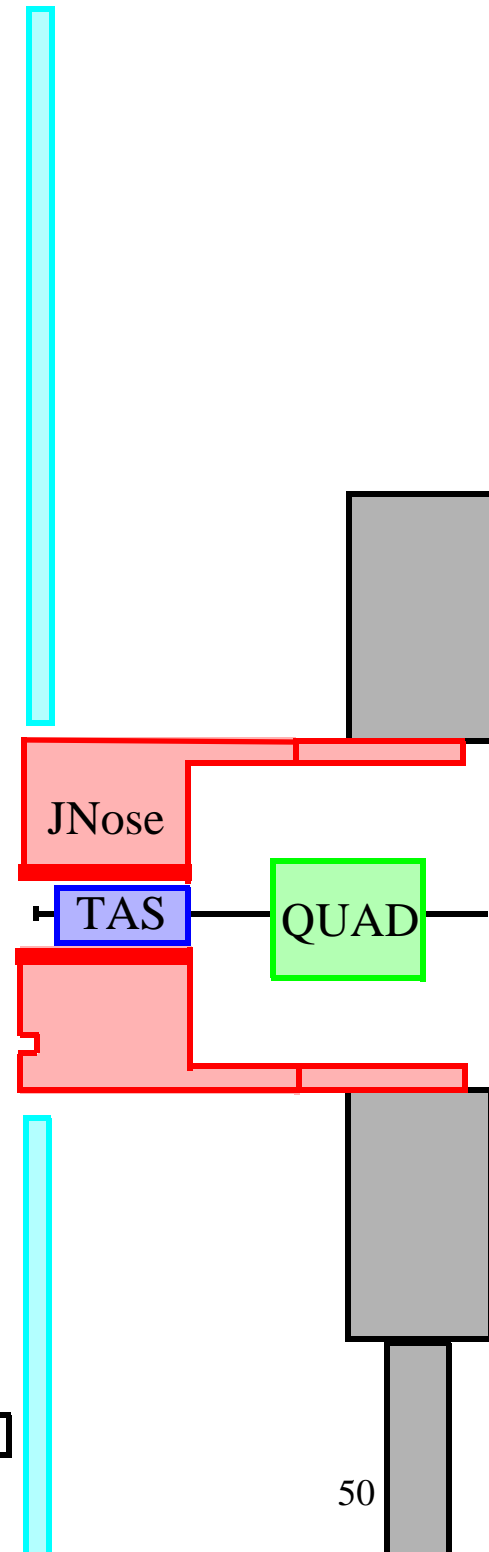

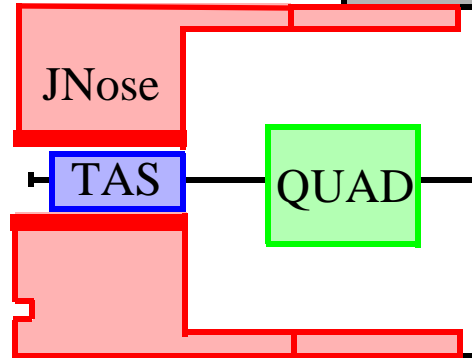
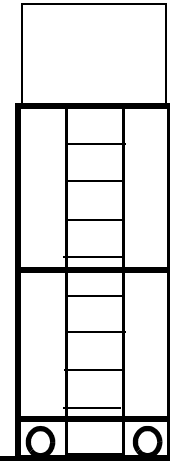
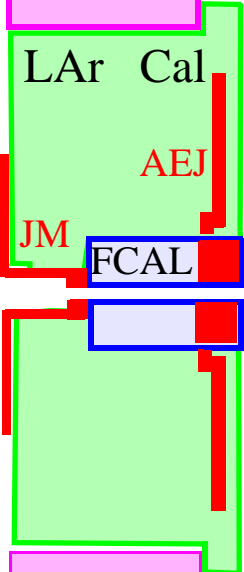
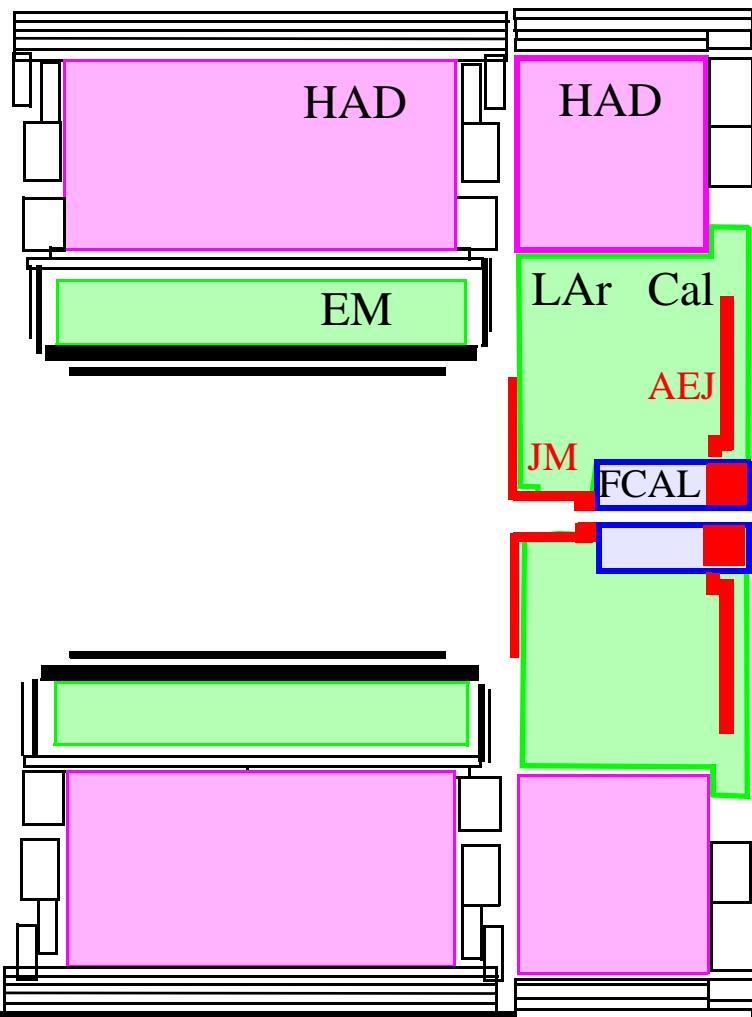

Rails

ACCESS

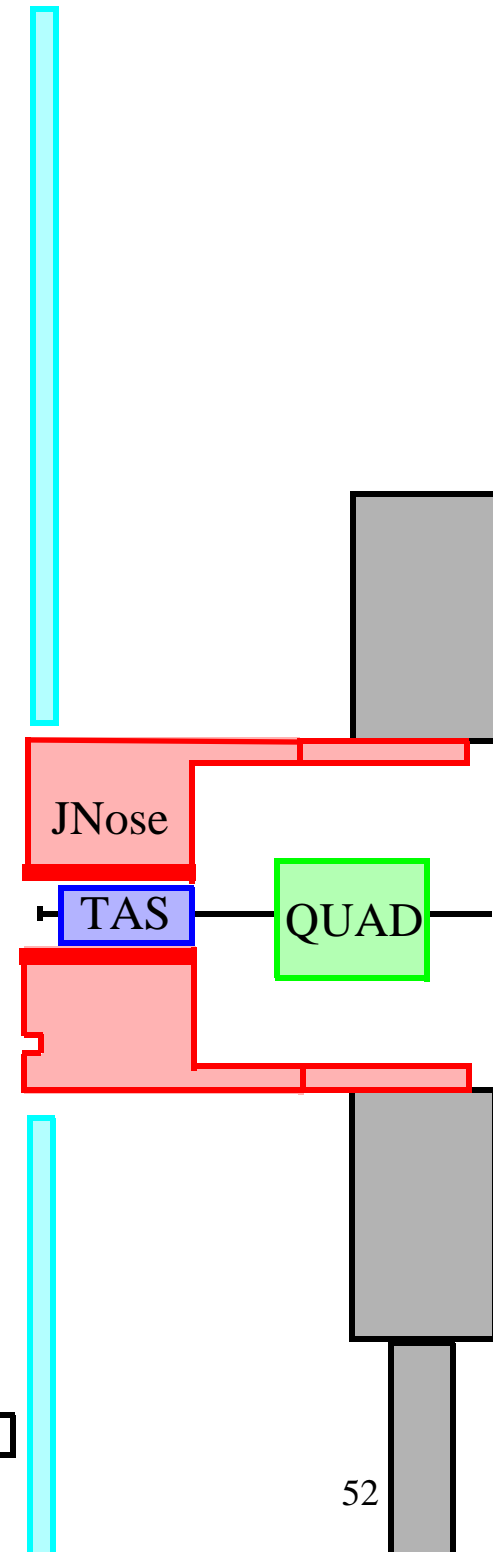
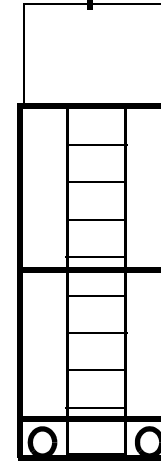
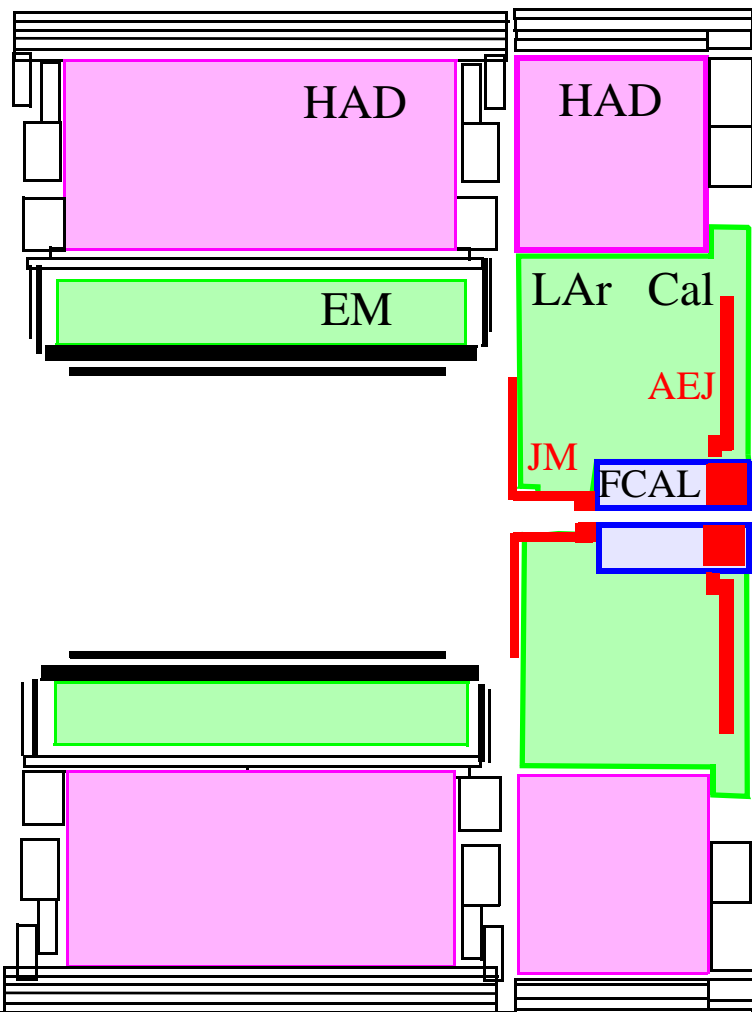

ACCESS

Rails

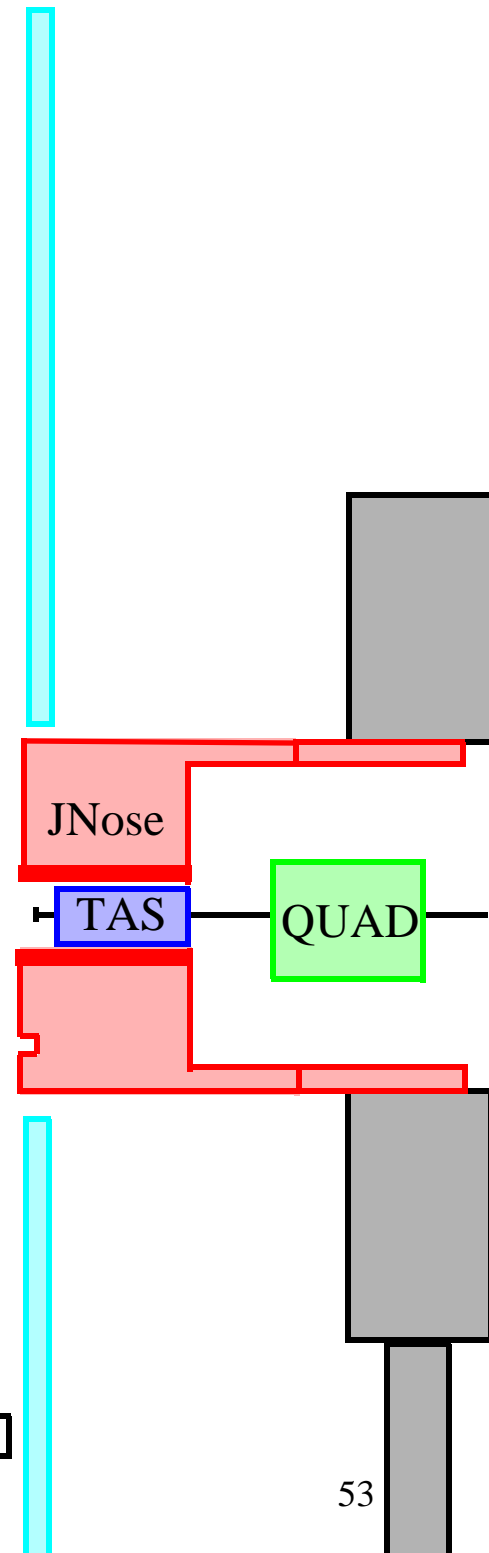
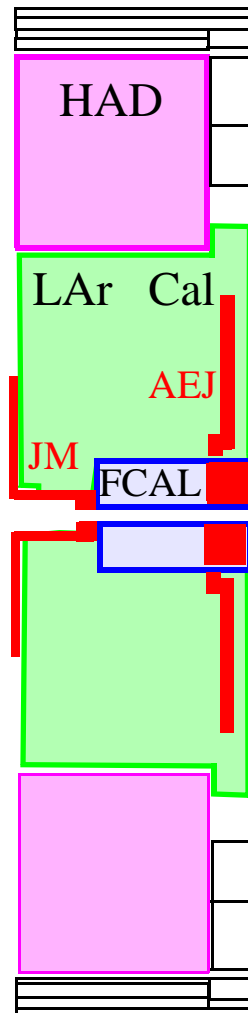
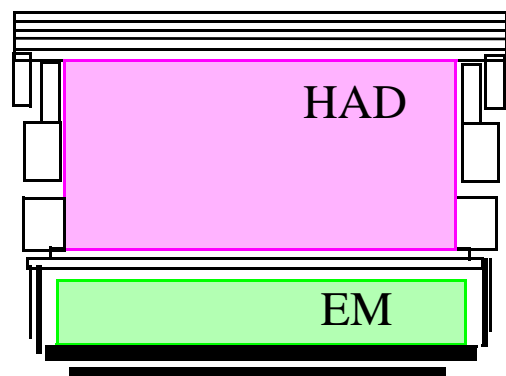

ACCESS

Rails

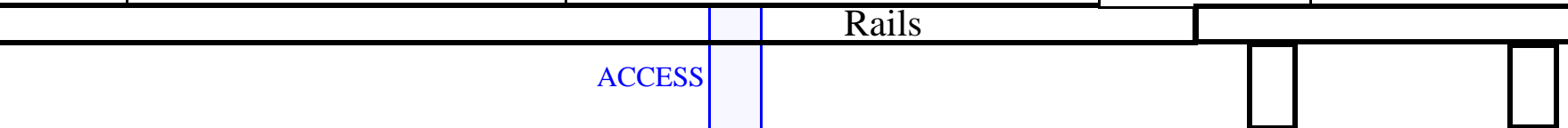
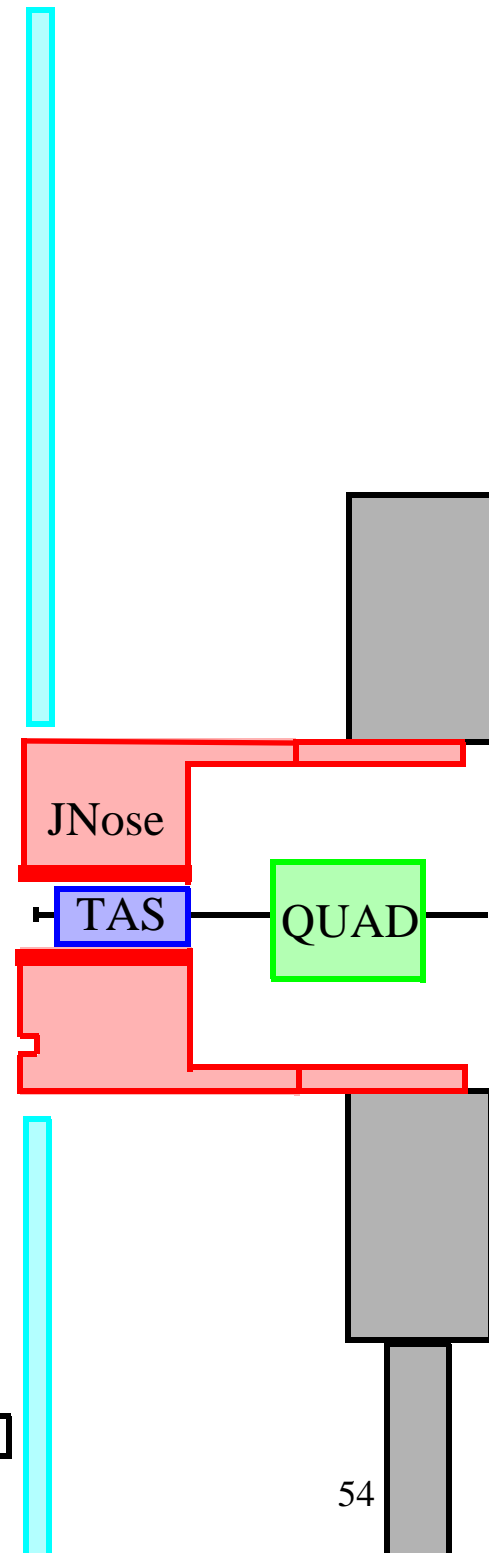
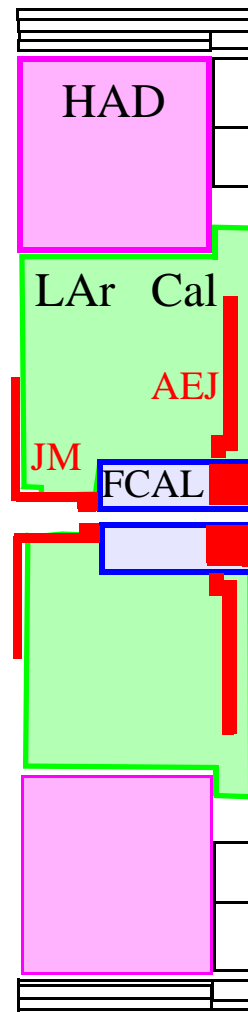
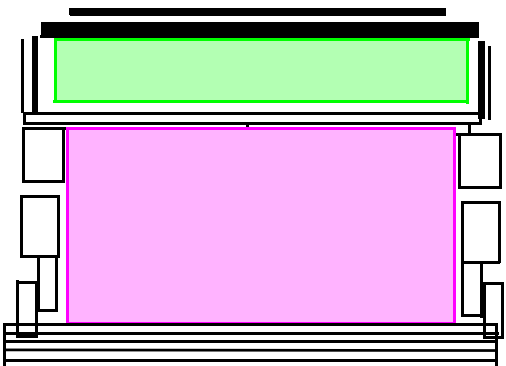

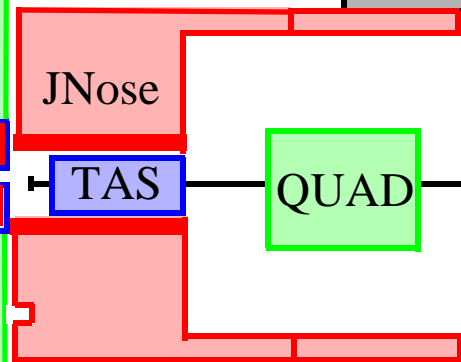
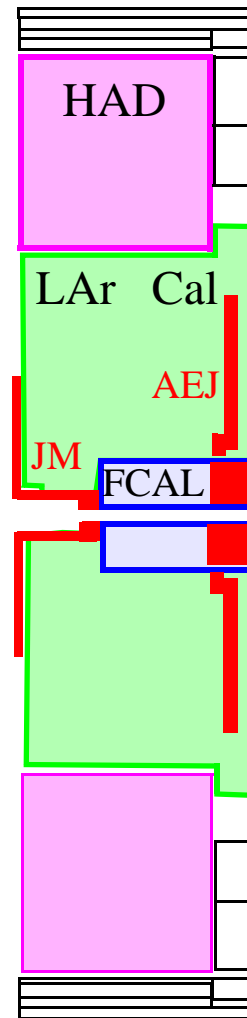
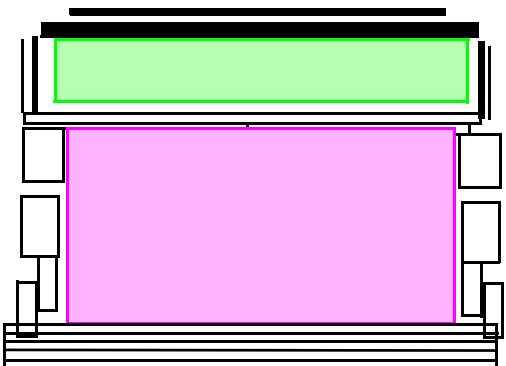
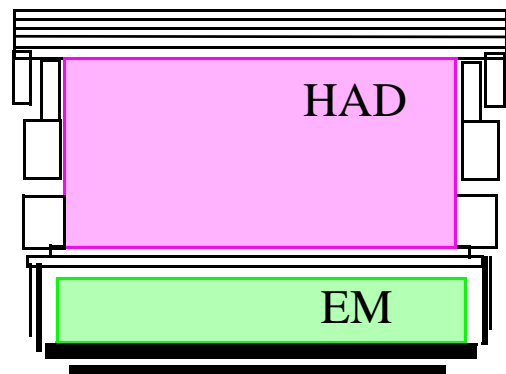

ACCESS

RAILS

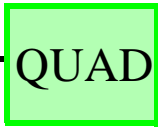
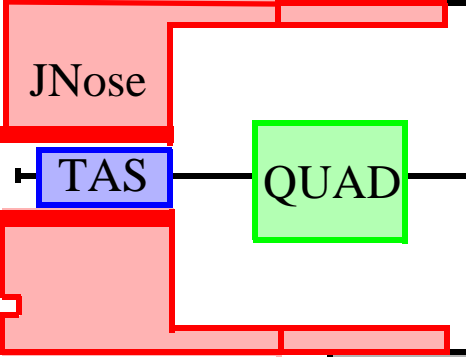
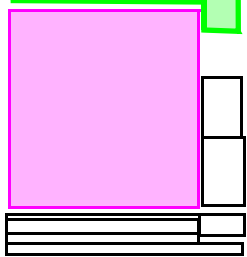
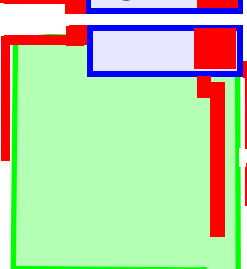
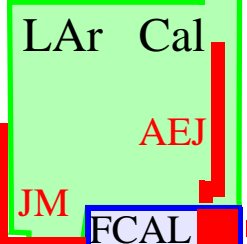
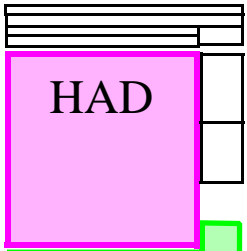
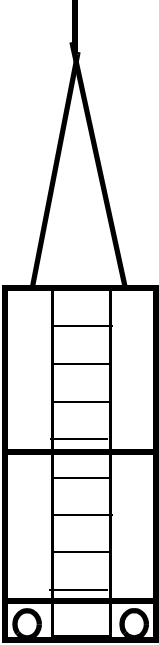
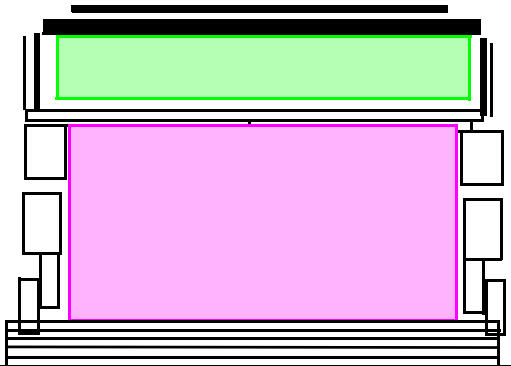
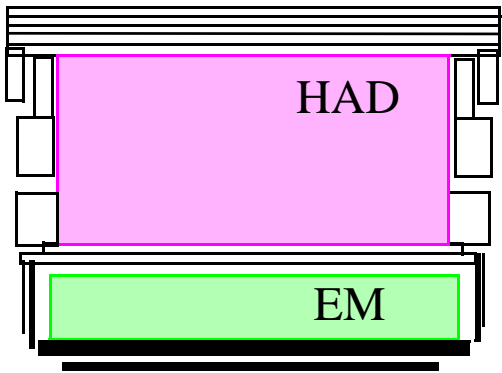

ACCESS

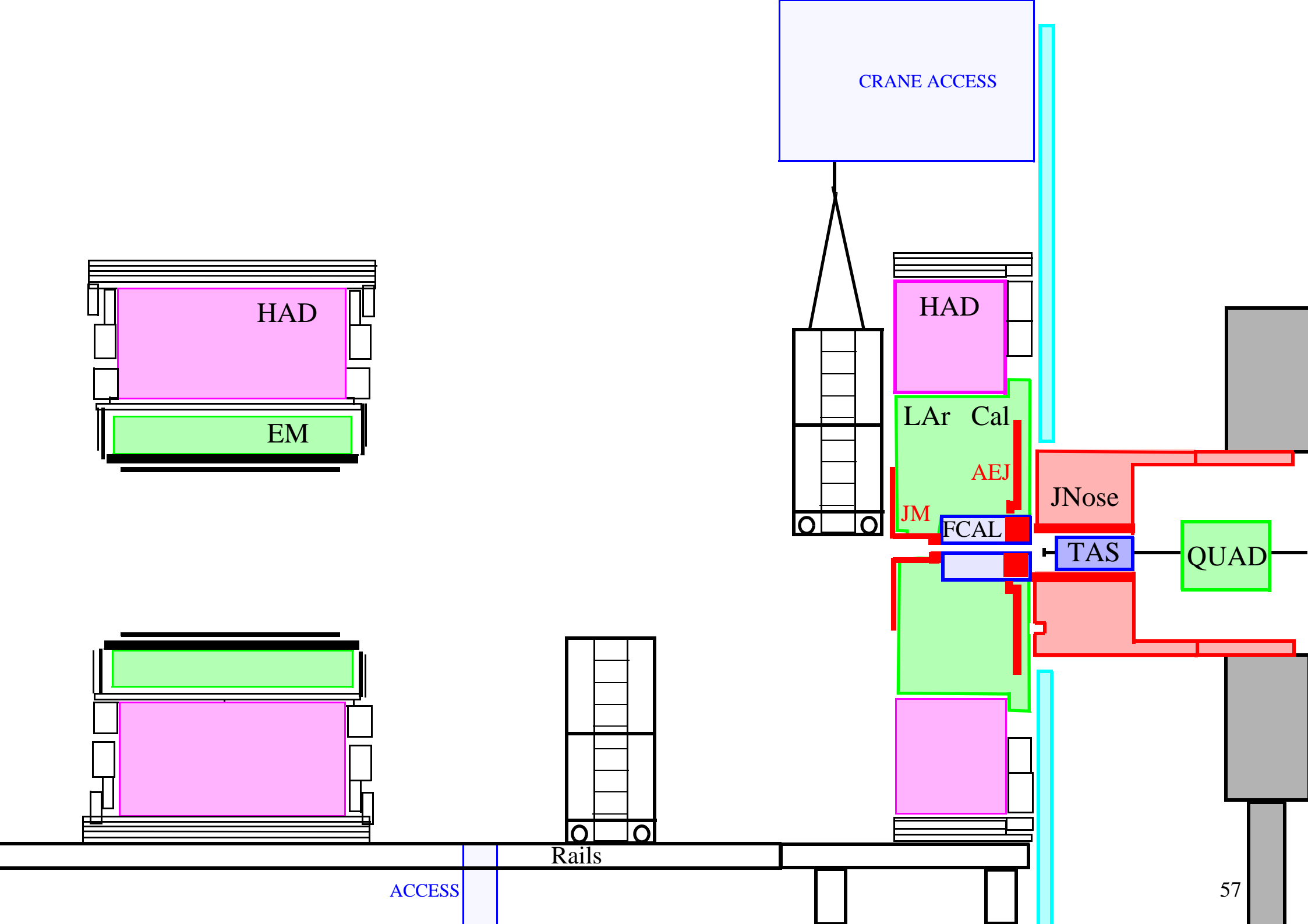

CRANE ACCESS

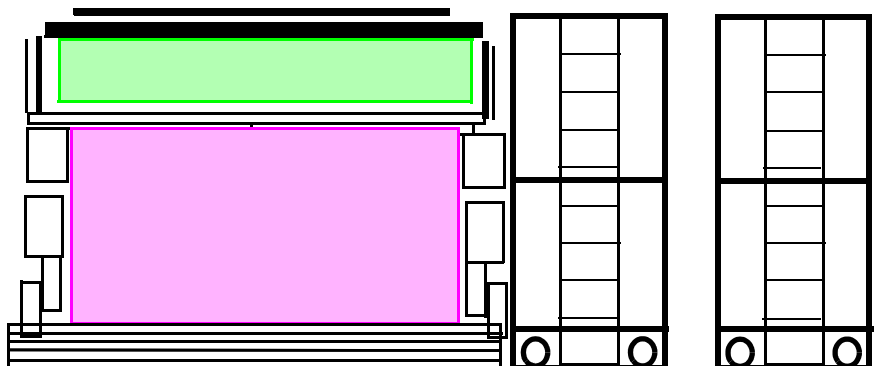
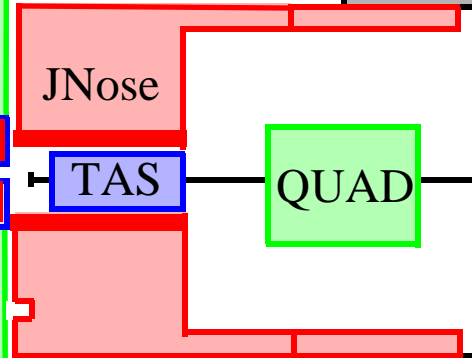
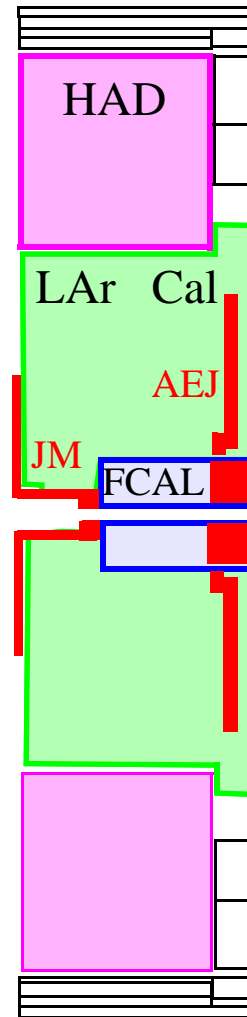
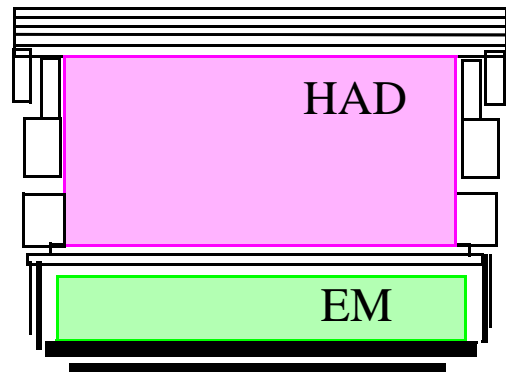

Rails

ACCESS

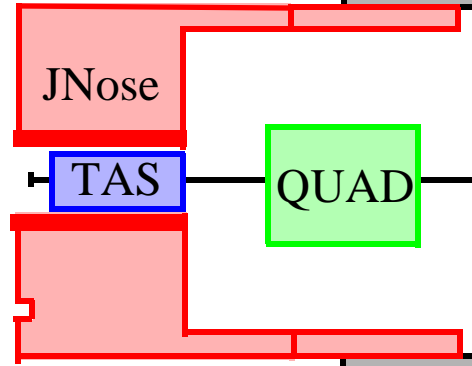
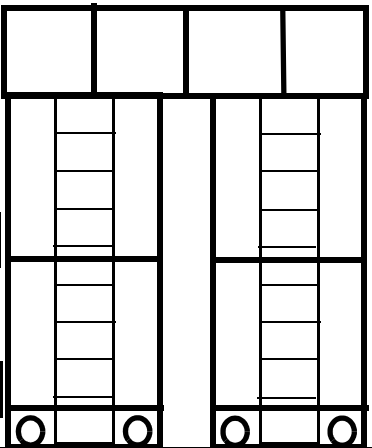
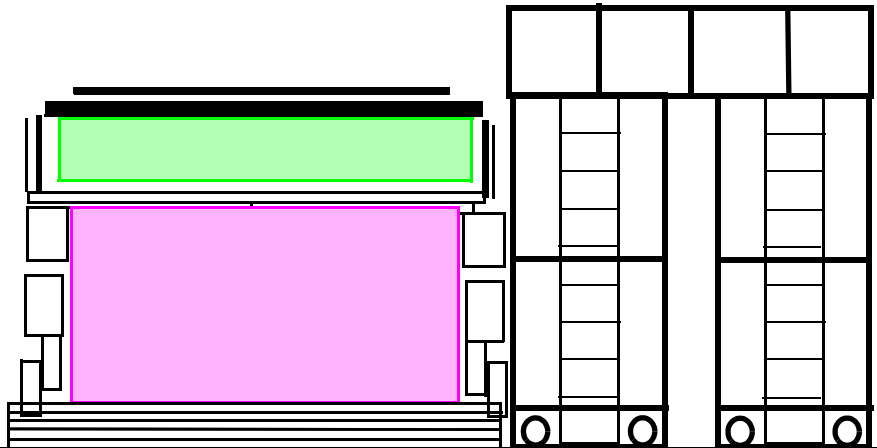
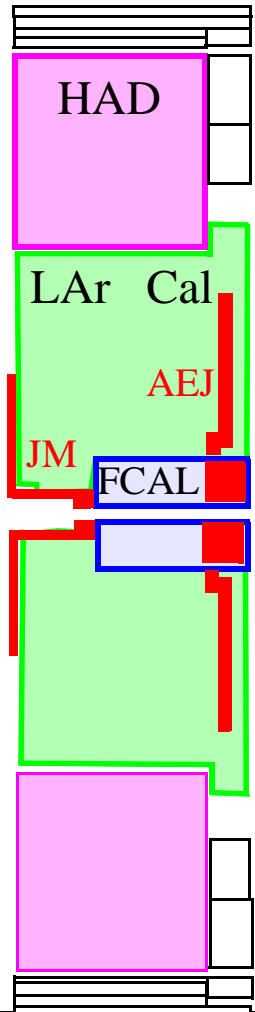
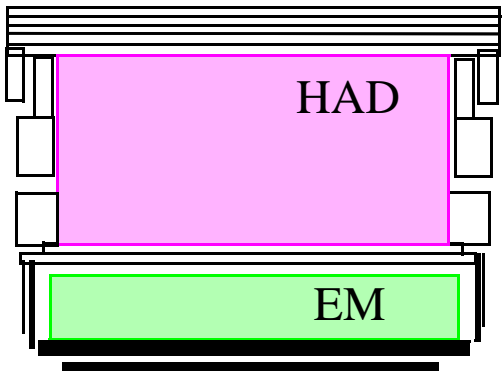

ACCESS

Rails

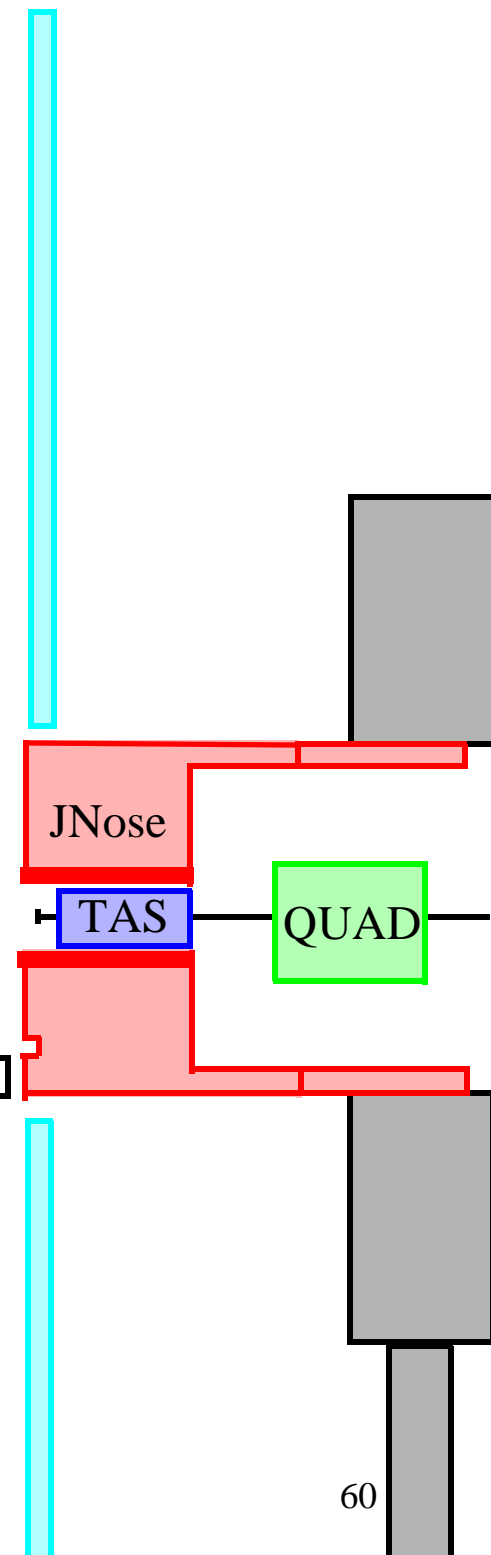
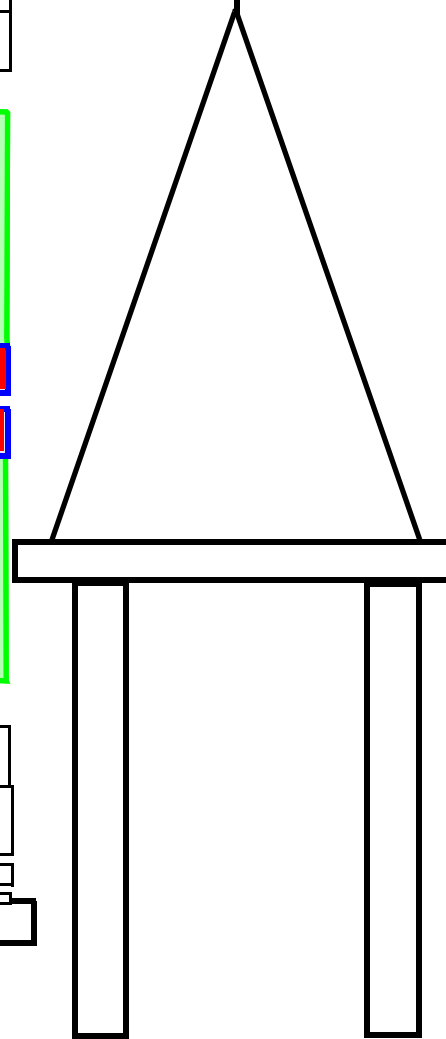
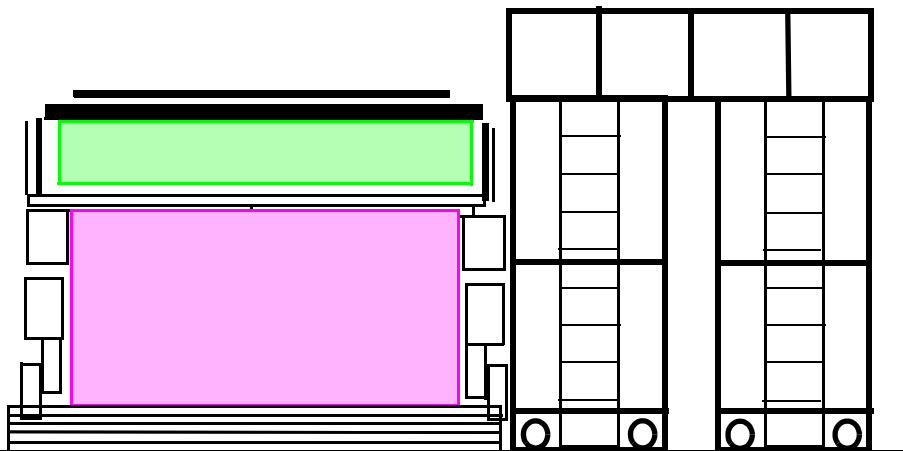
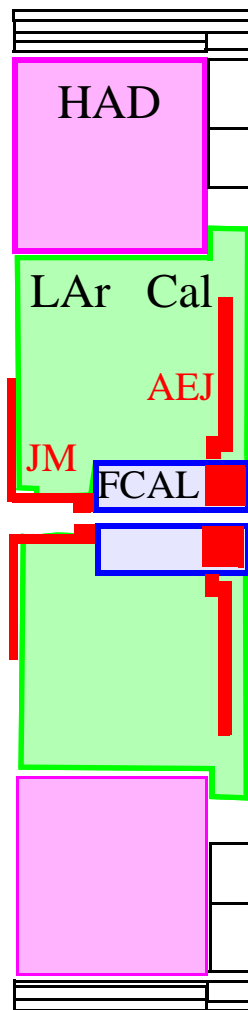
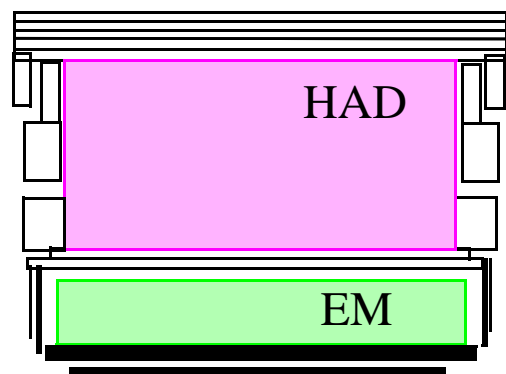

ACCESS

Rails

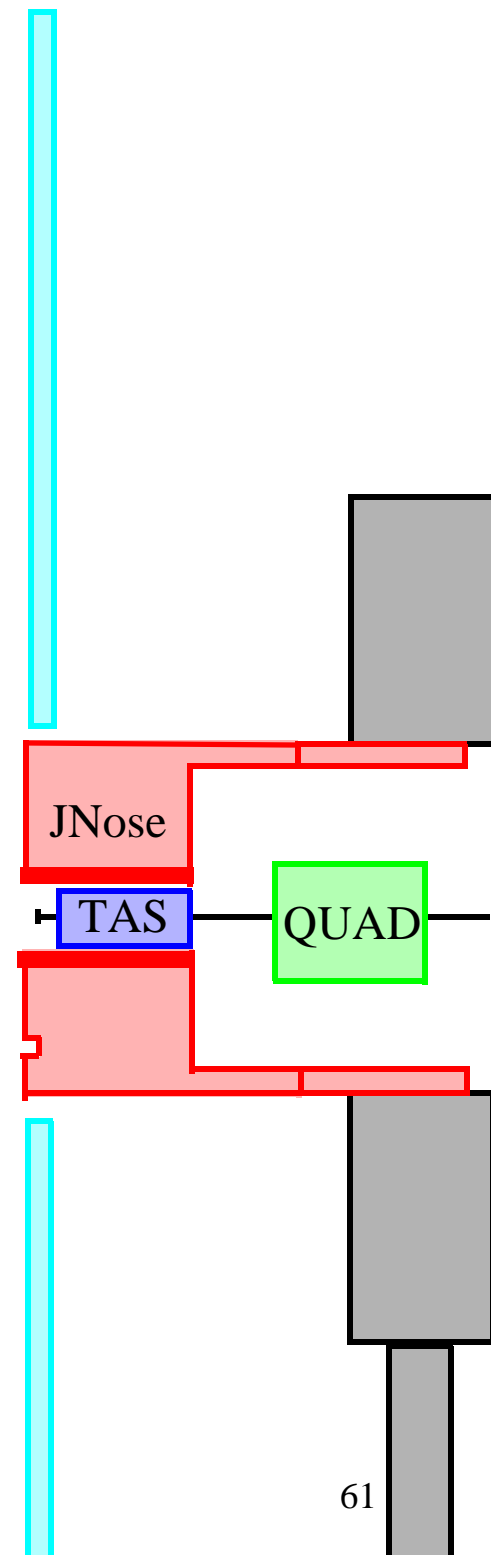
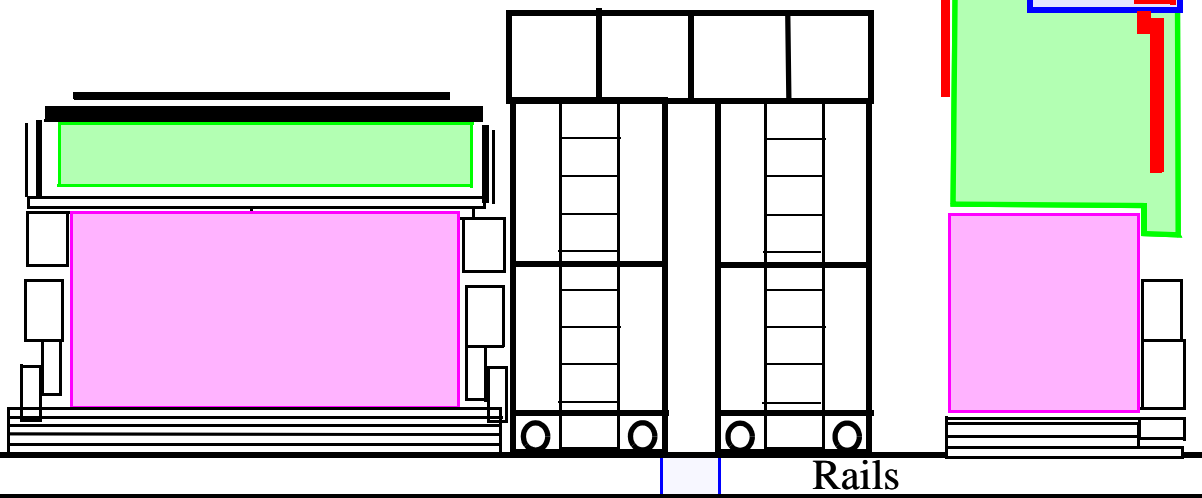
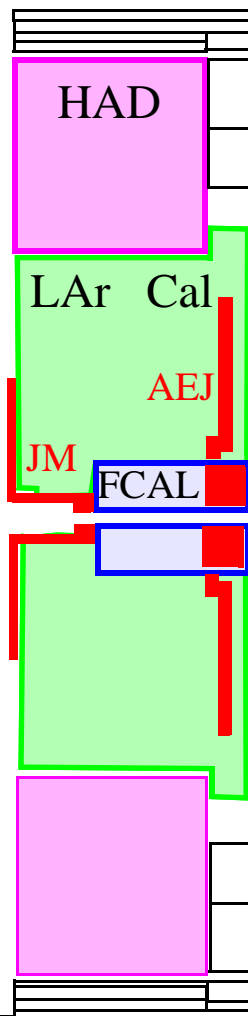
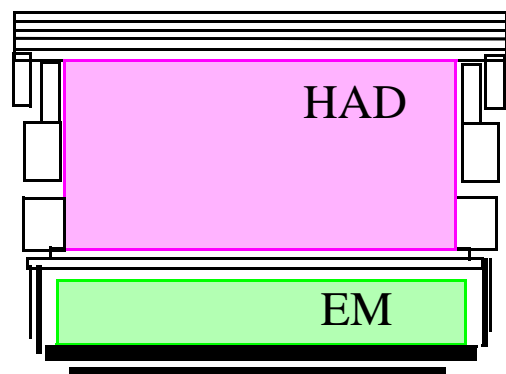

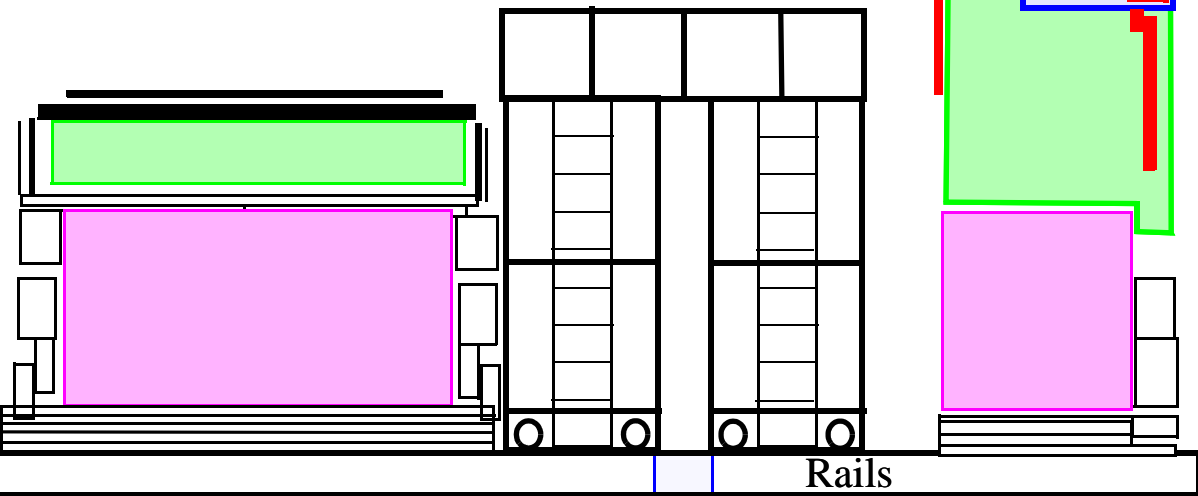
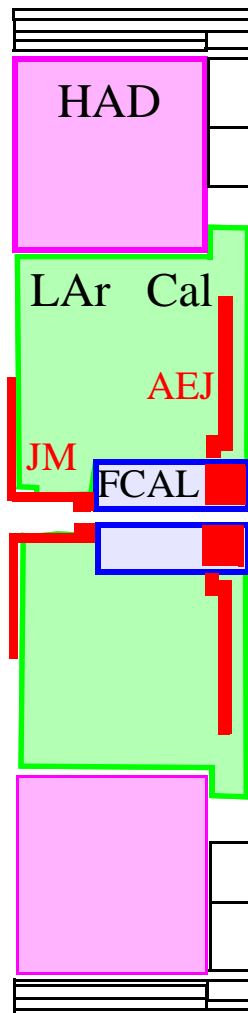
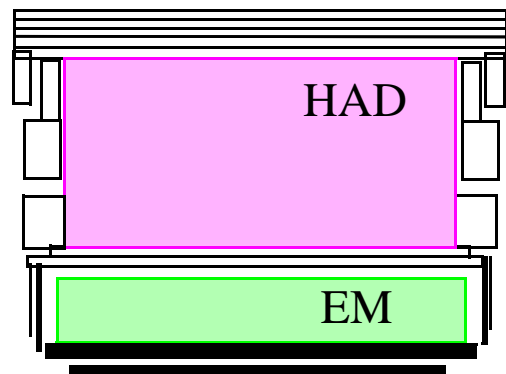

ACCESS

Rails

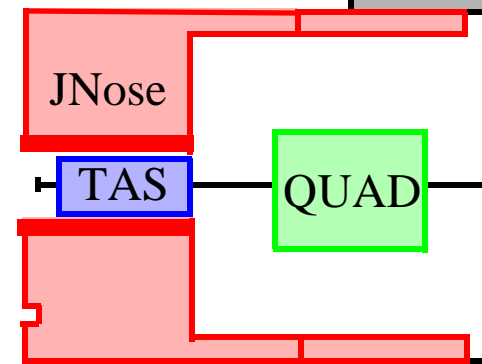

July 2006

The ID Barrel is installed from side A.

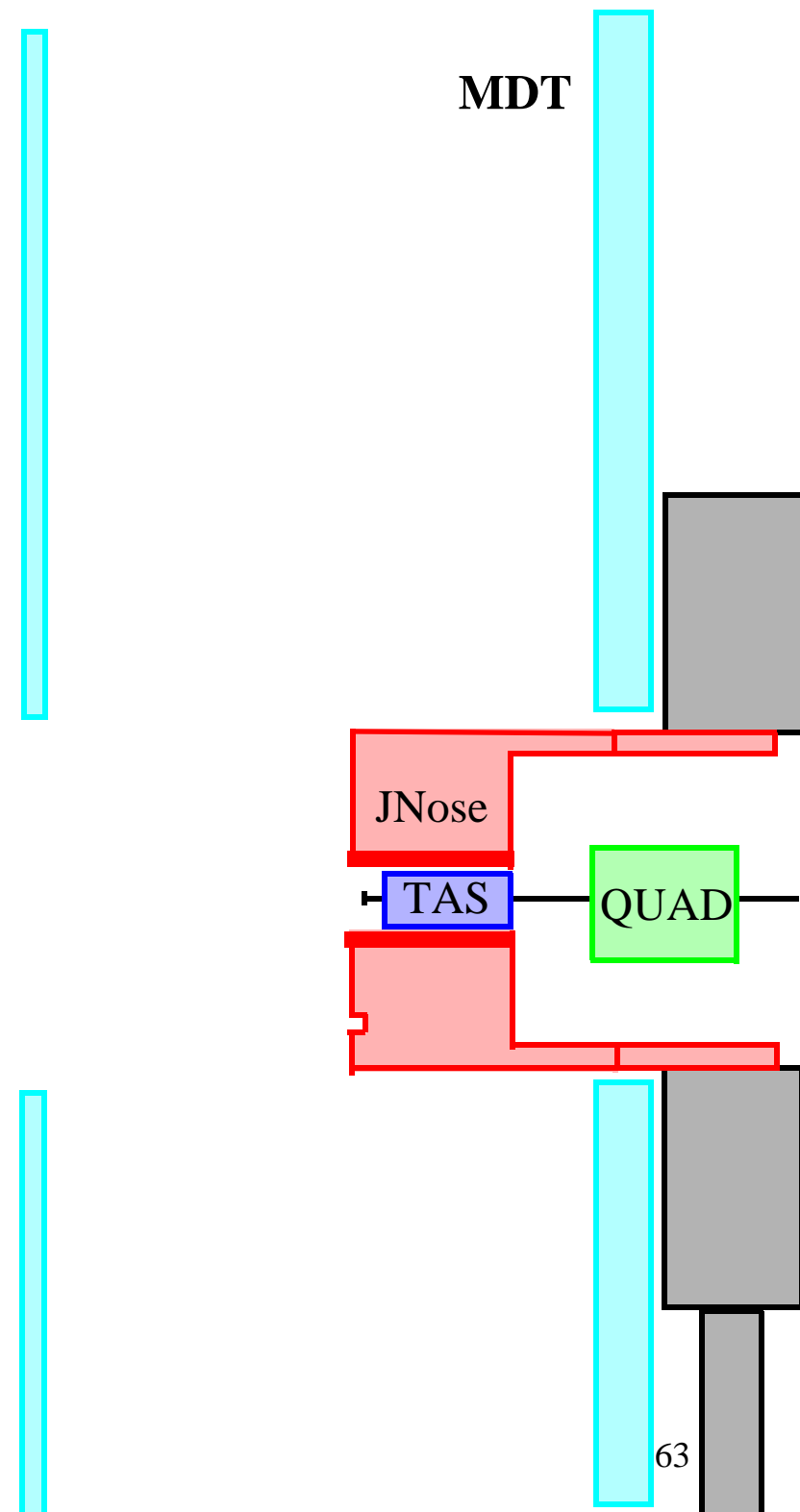
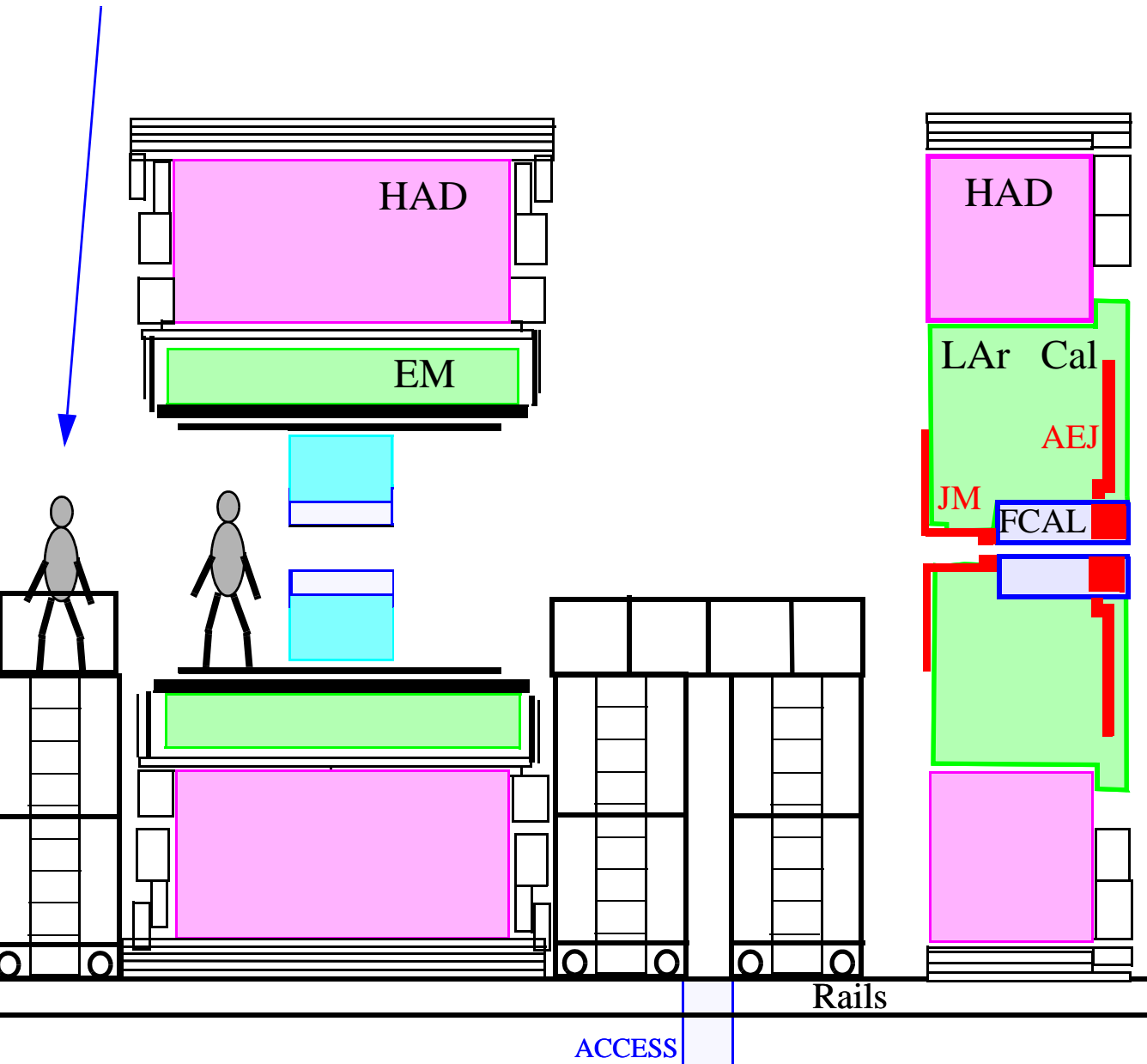

August 2006

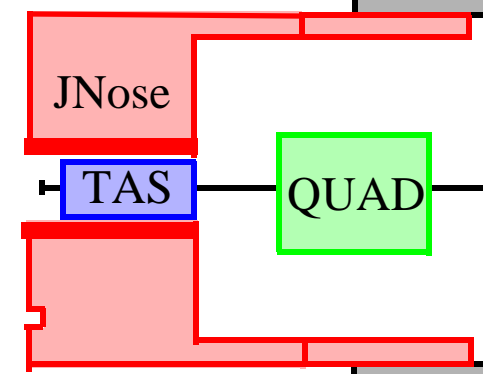
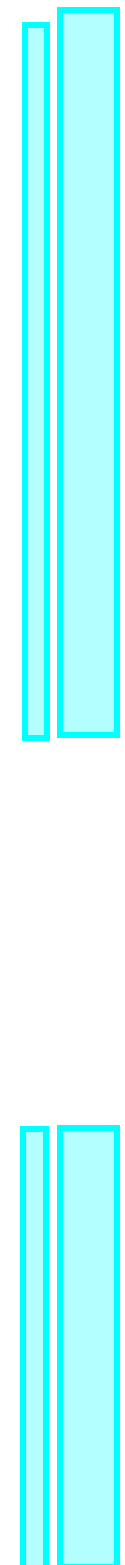
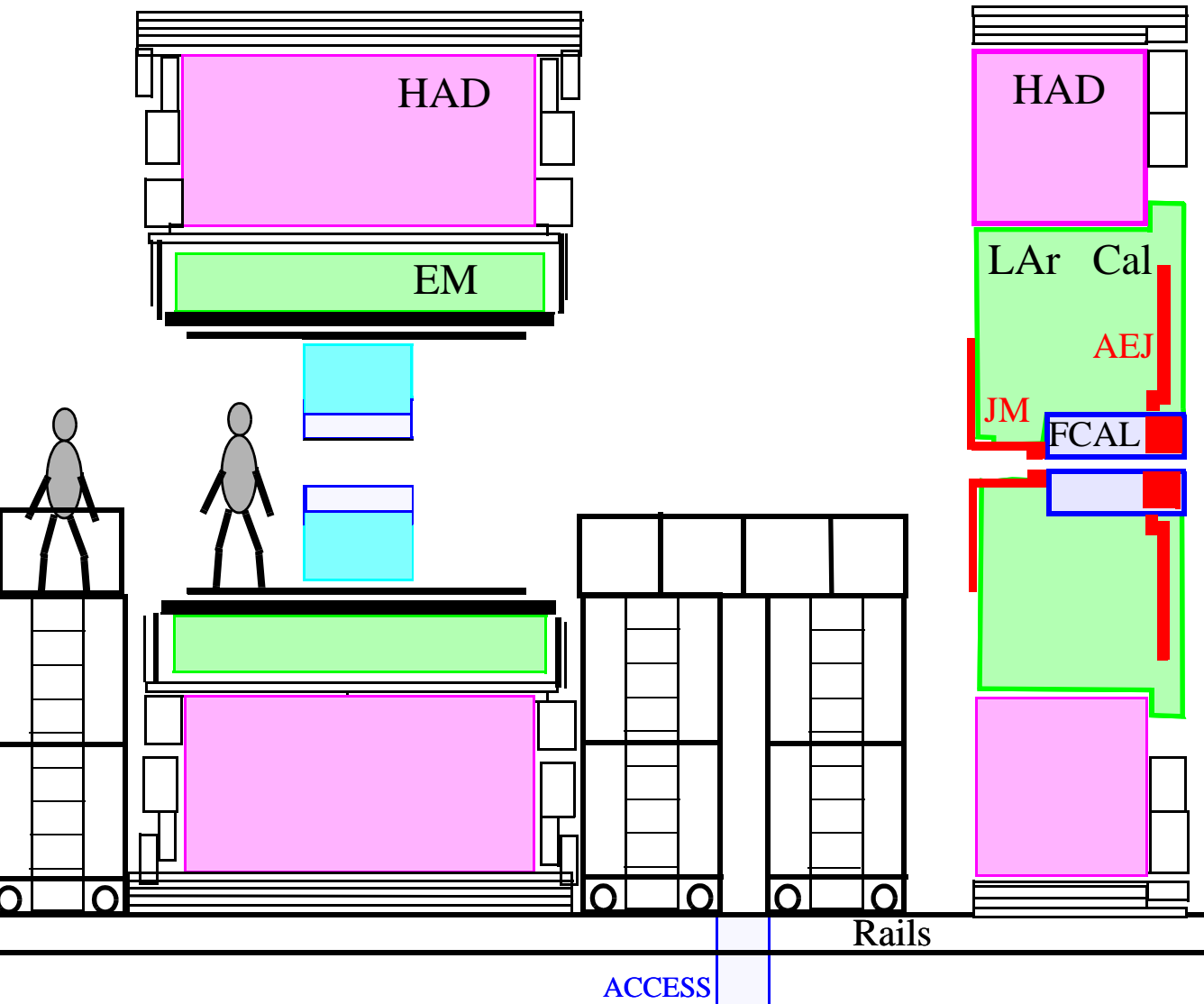

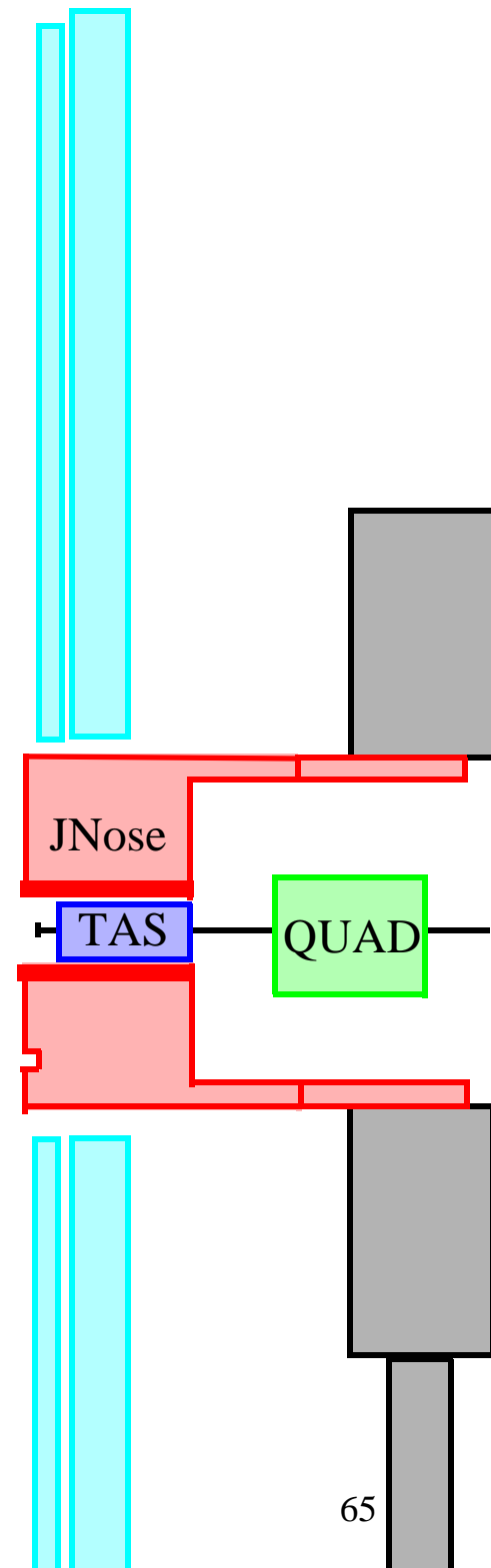
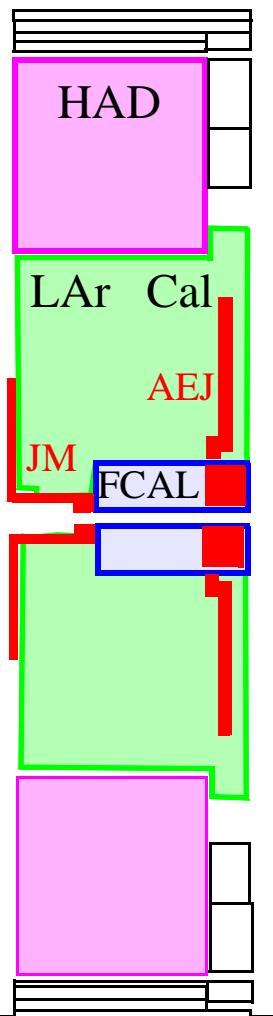
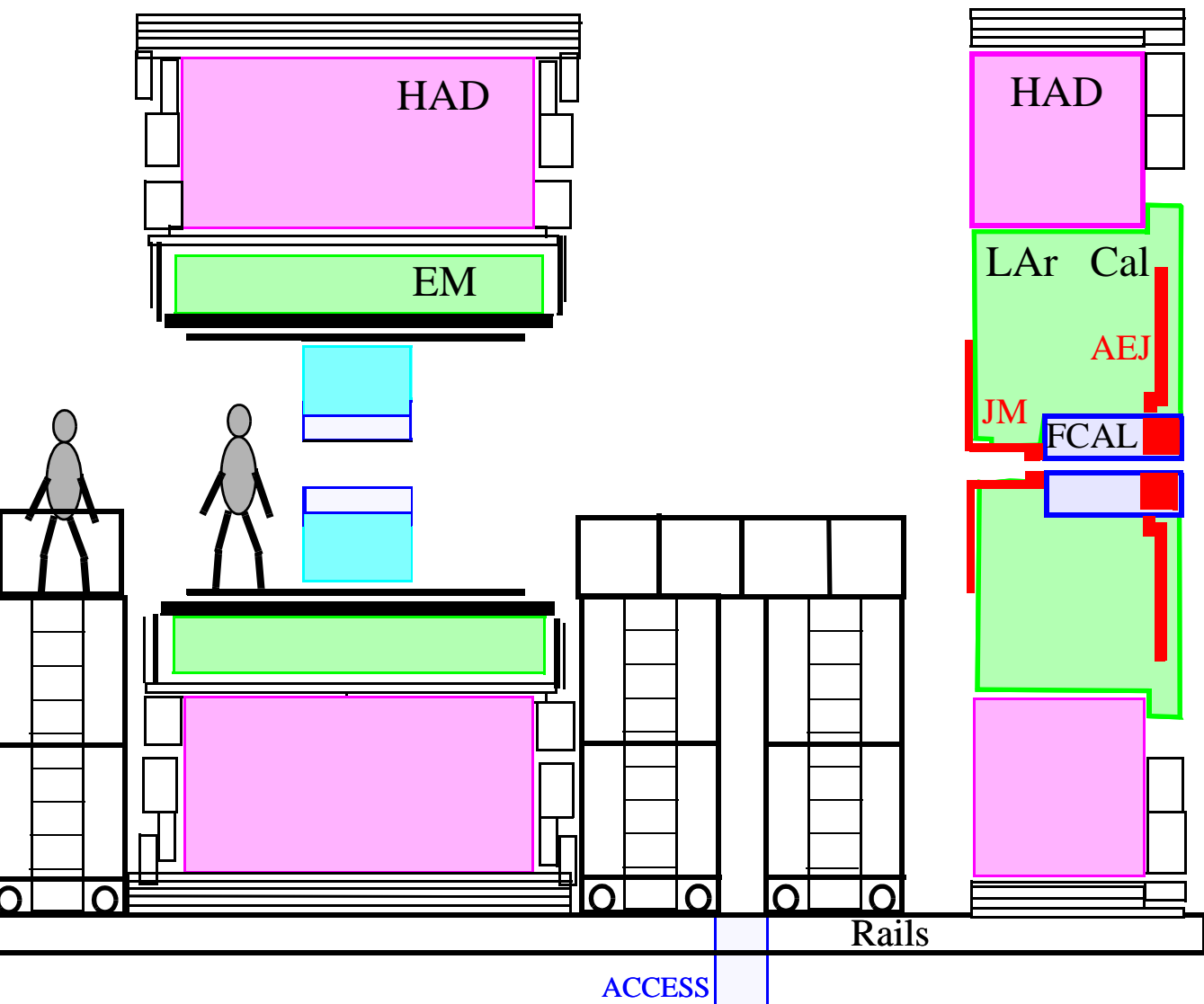

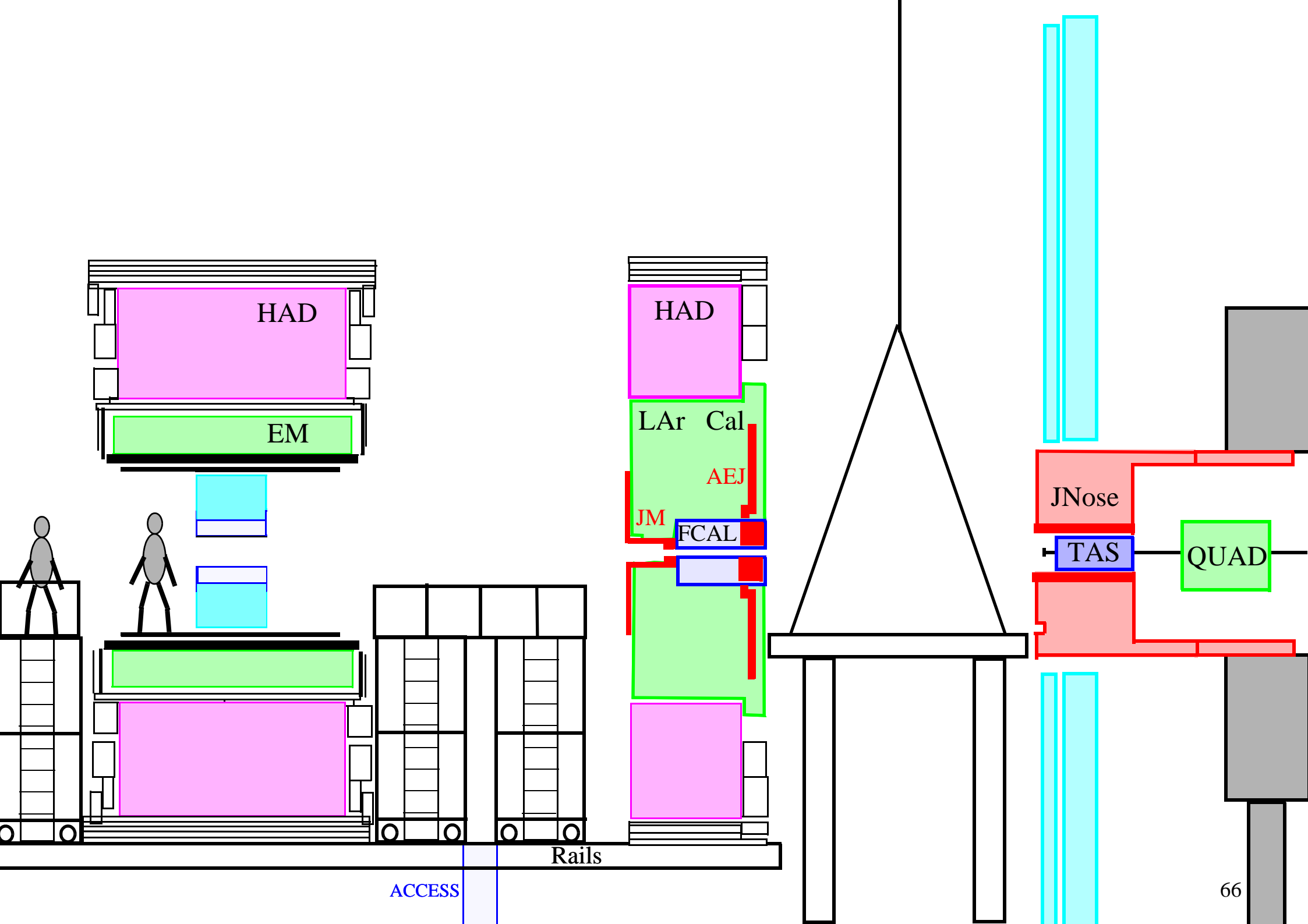

September 2006

Only small scaffolding is available during the toroid installation on side A.

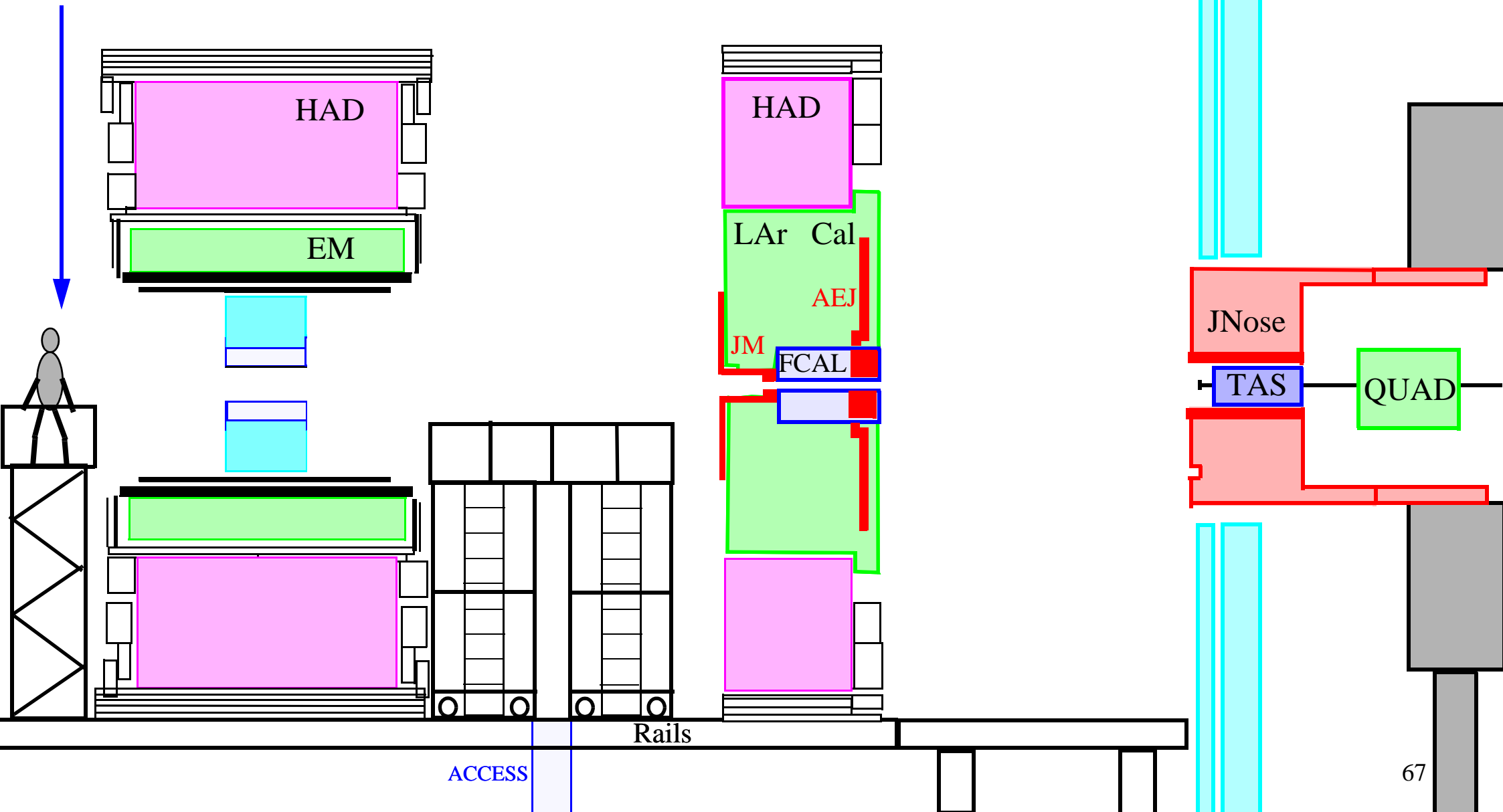

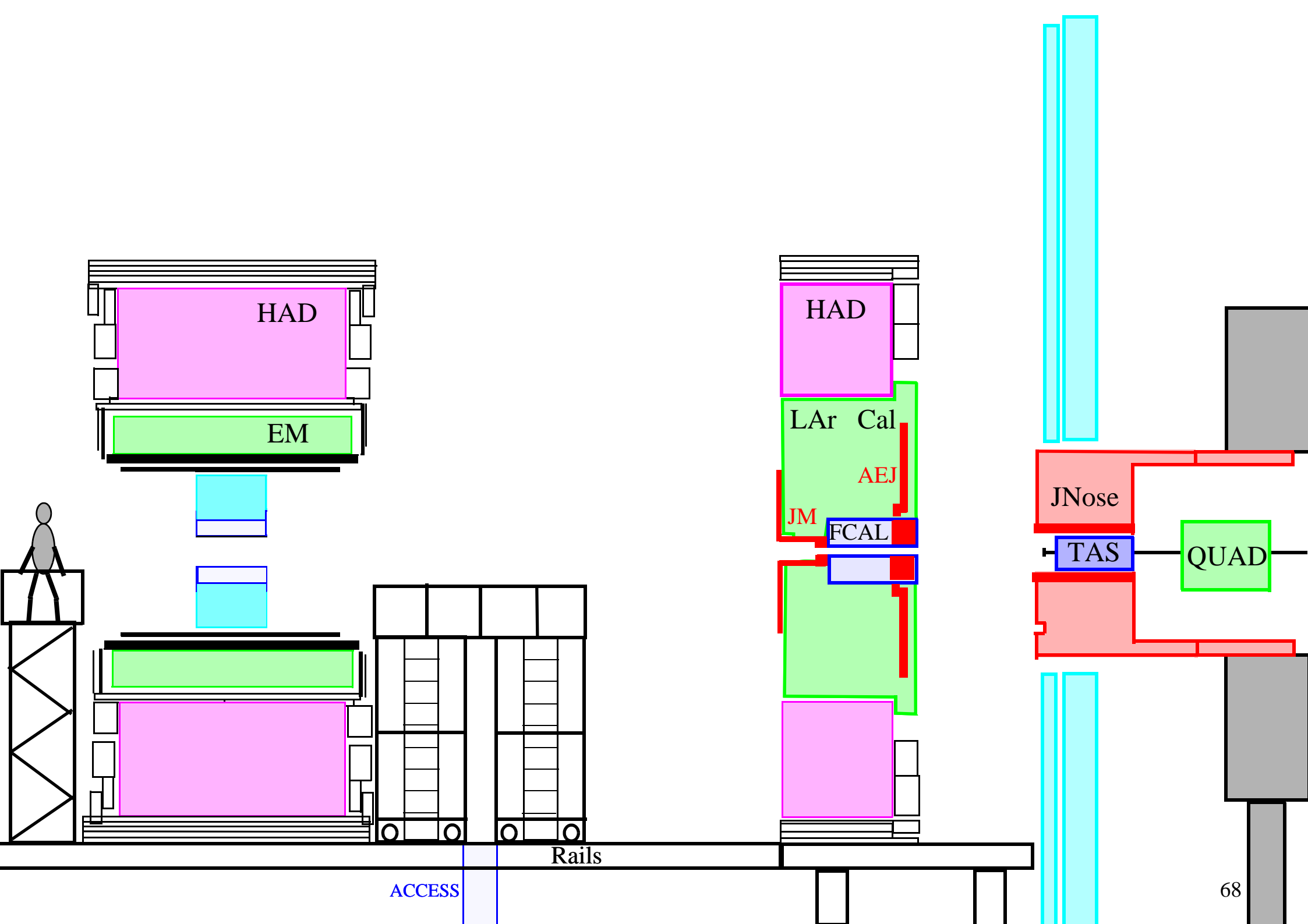

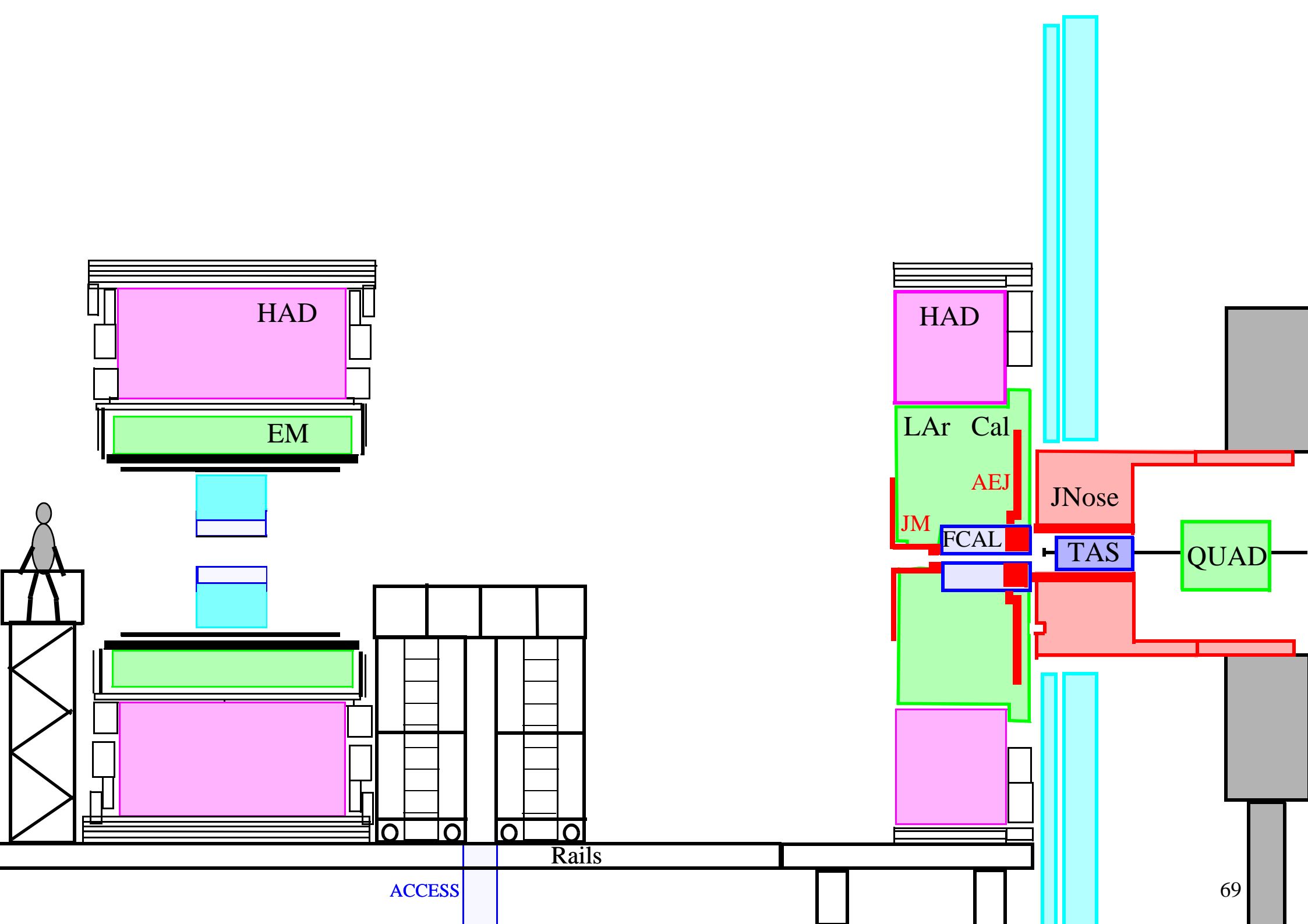

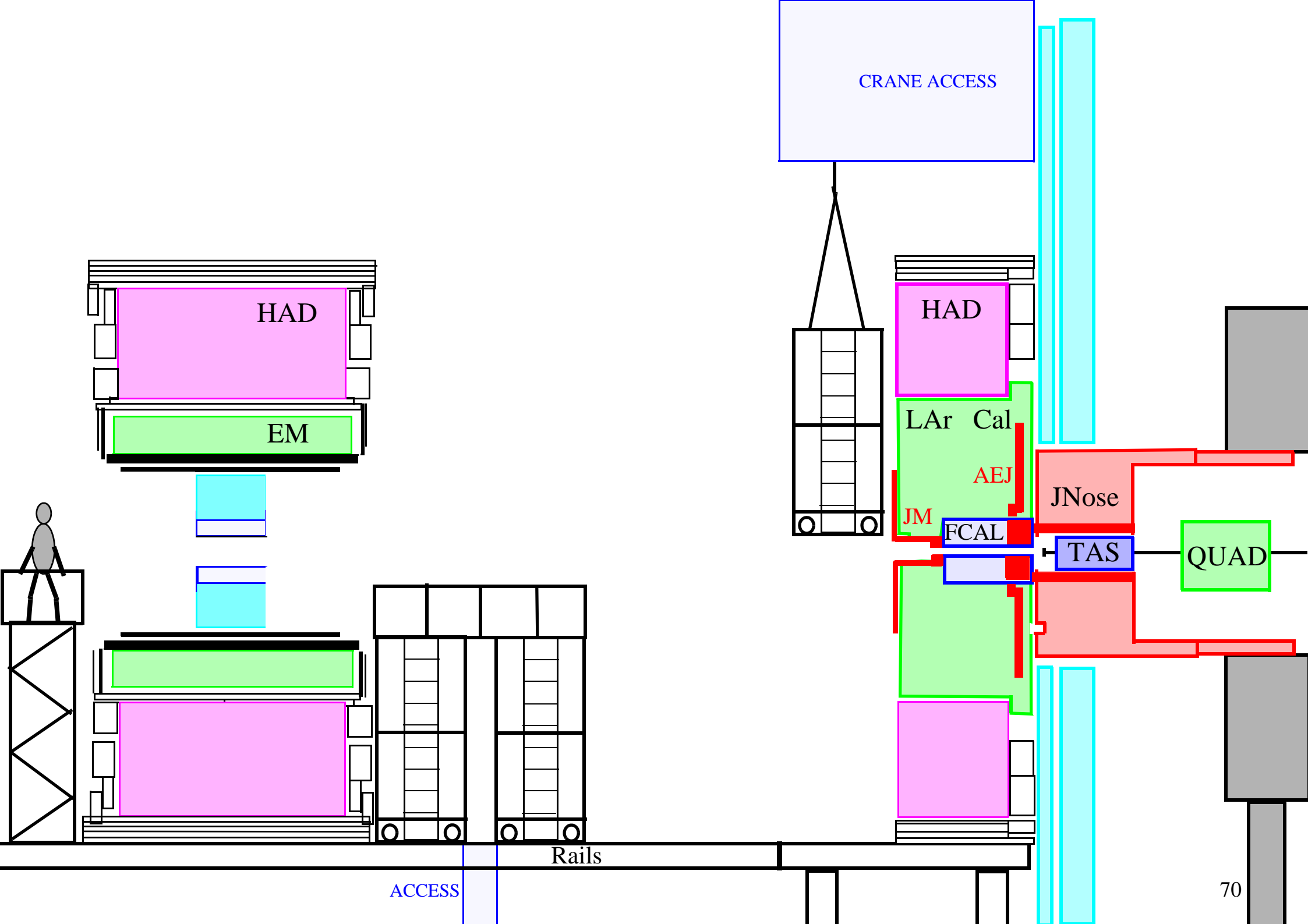

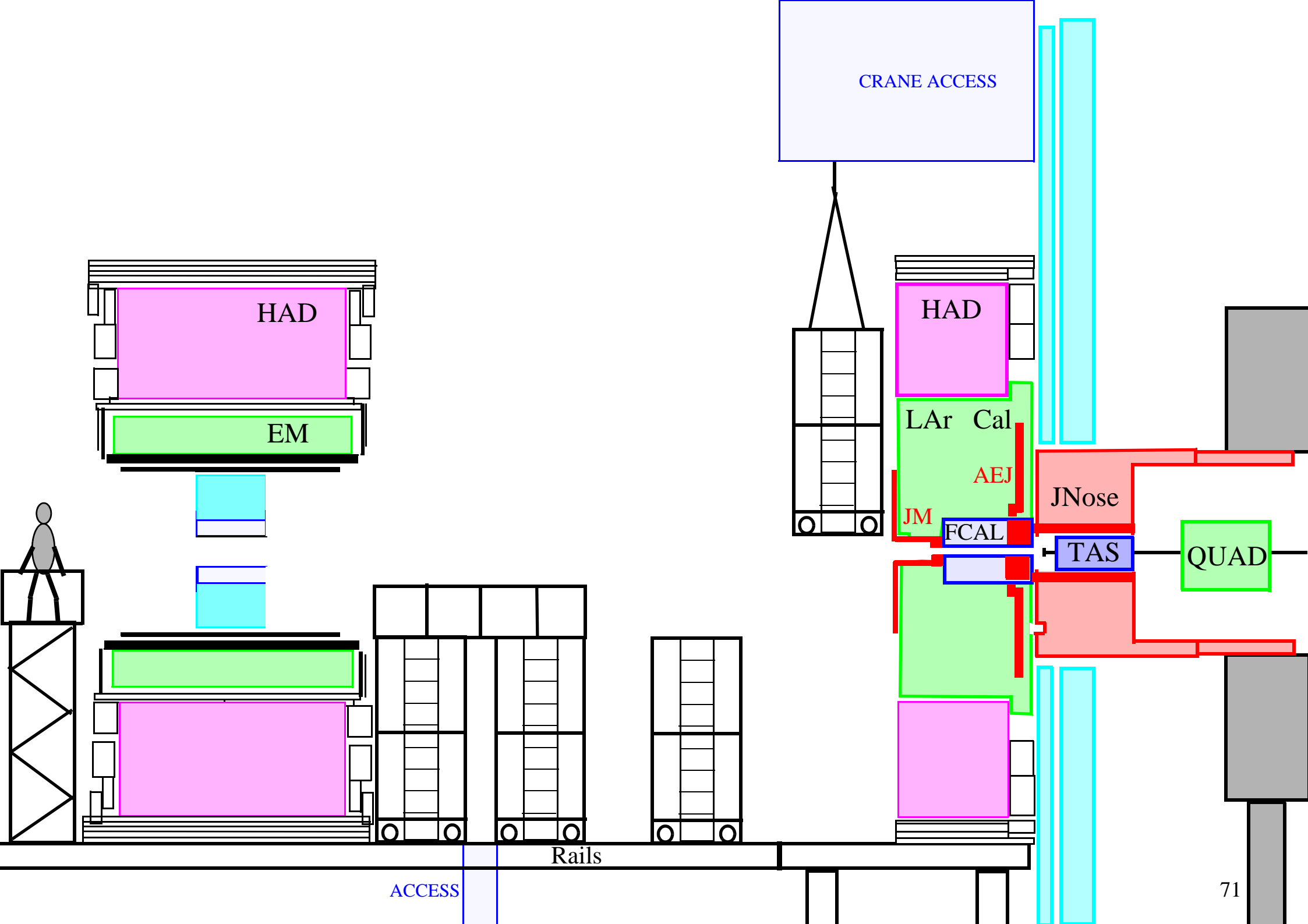

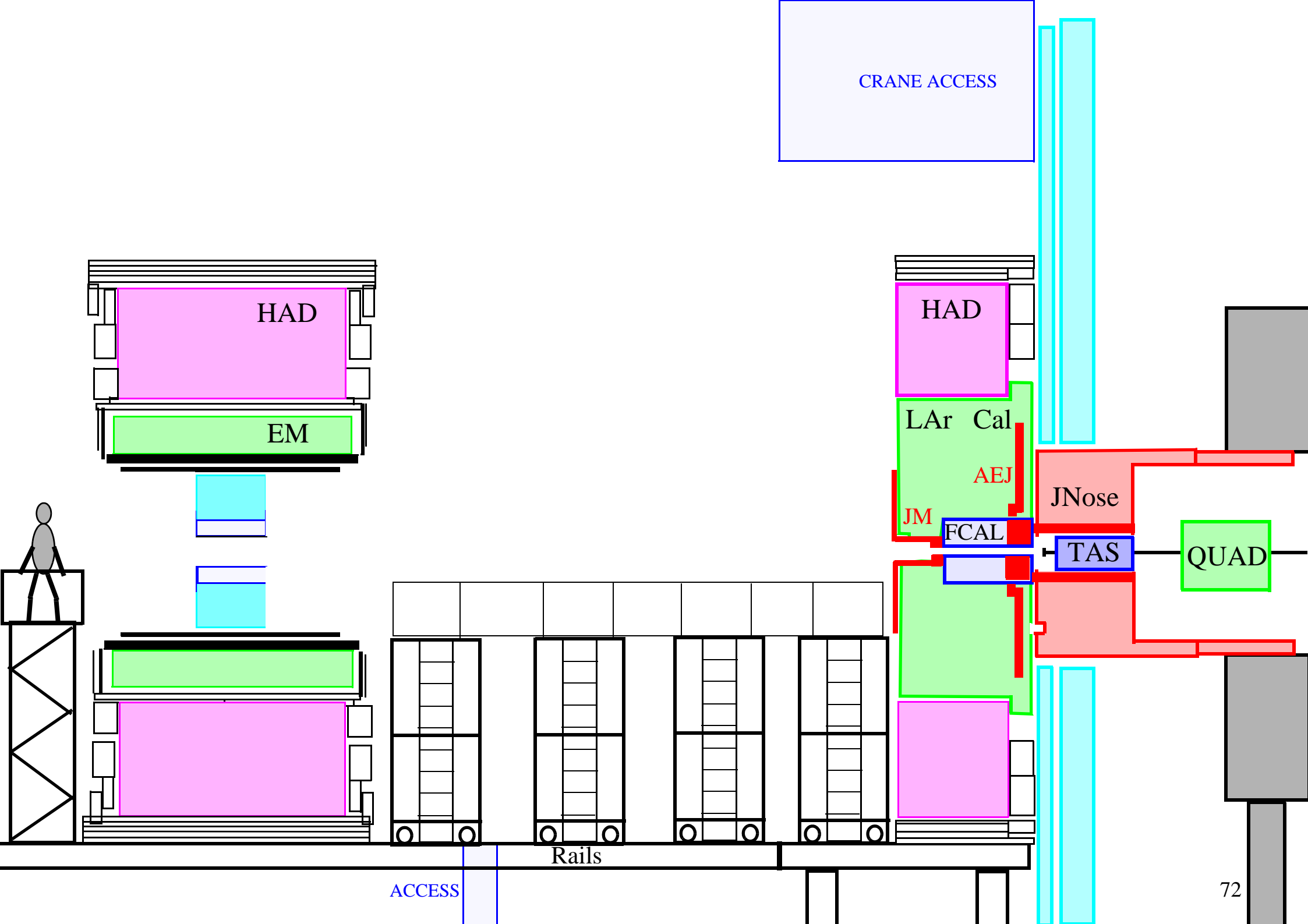

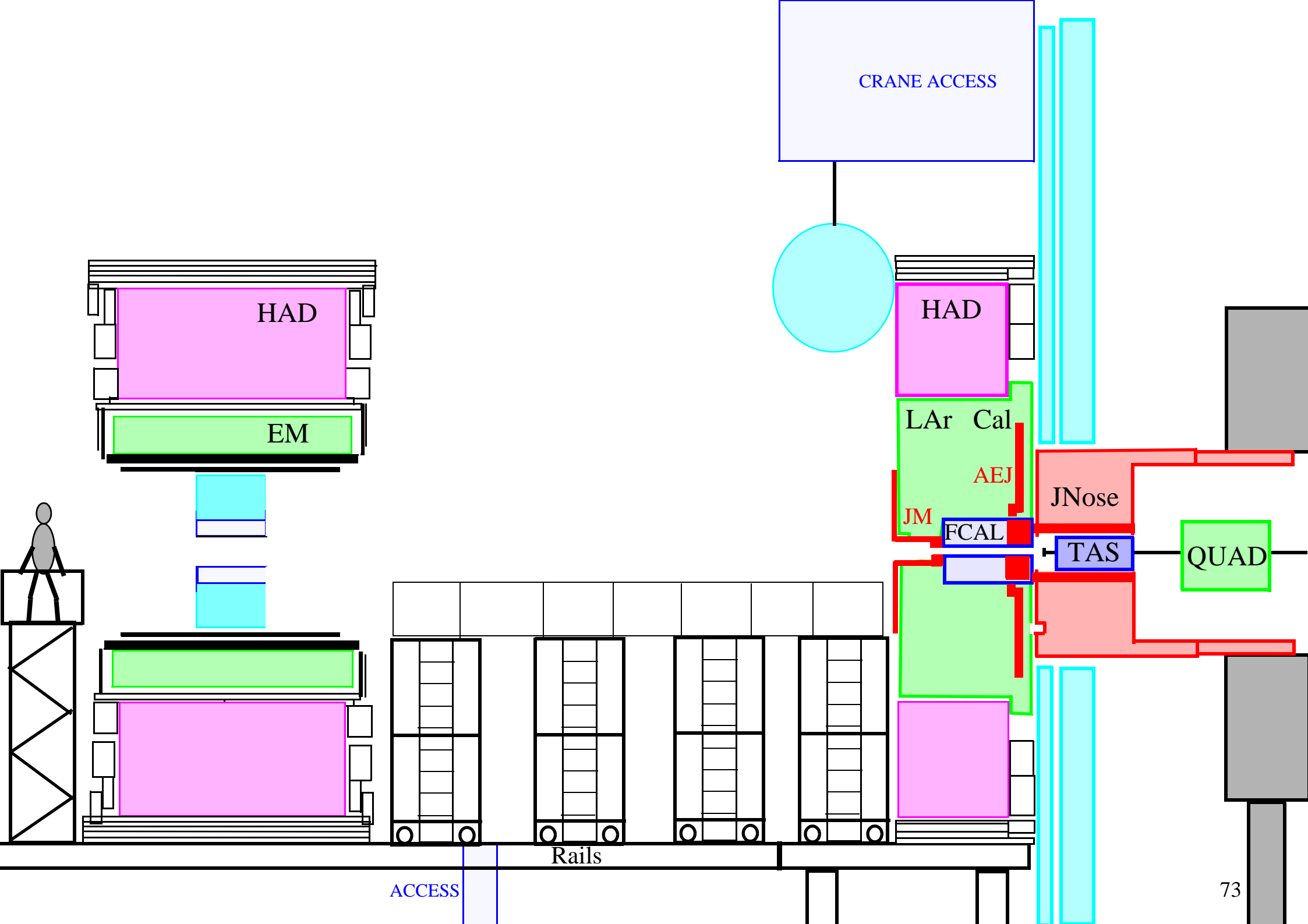

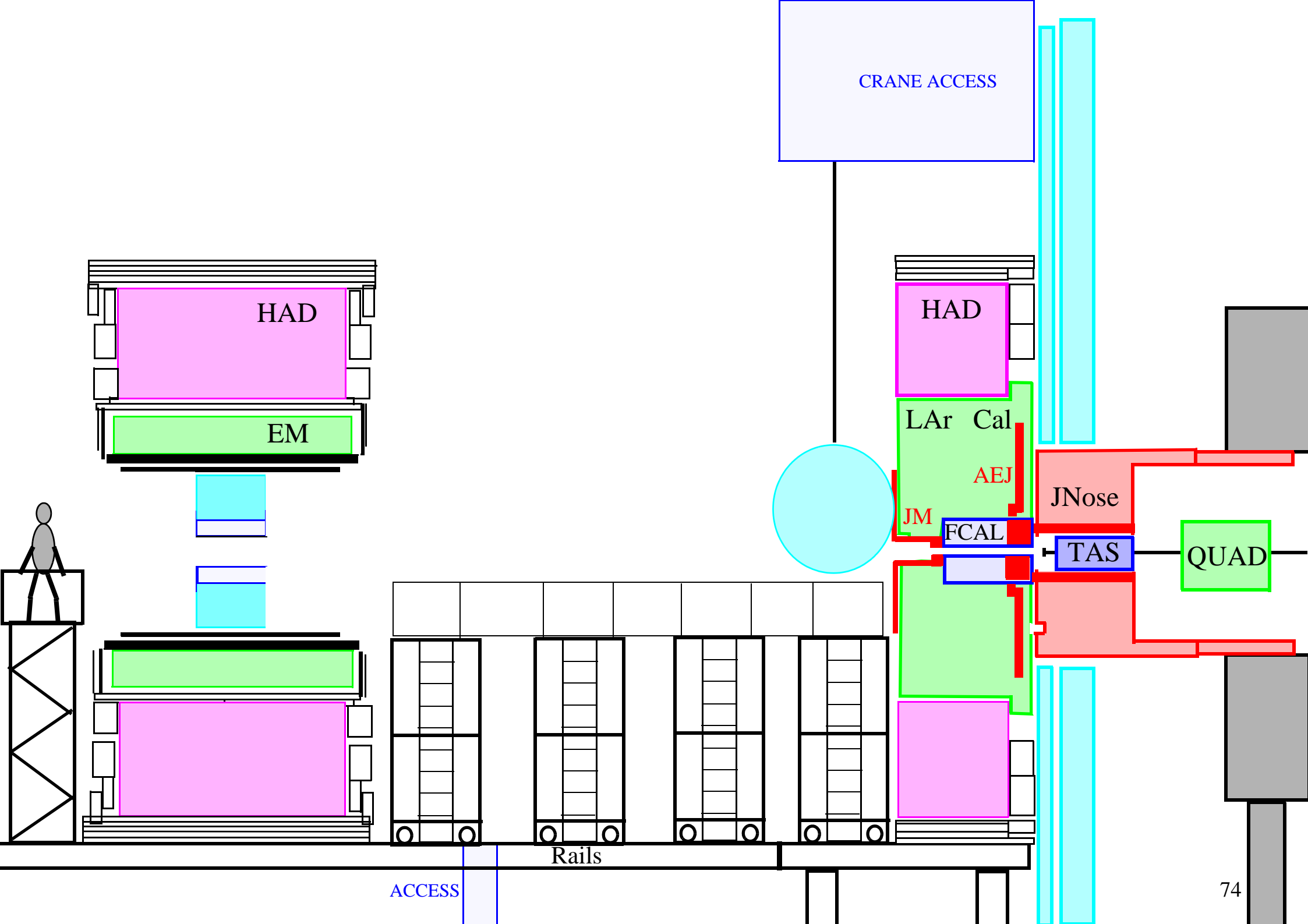

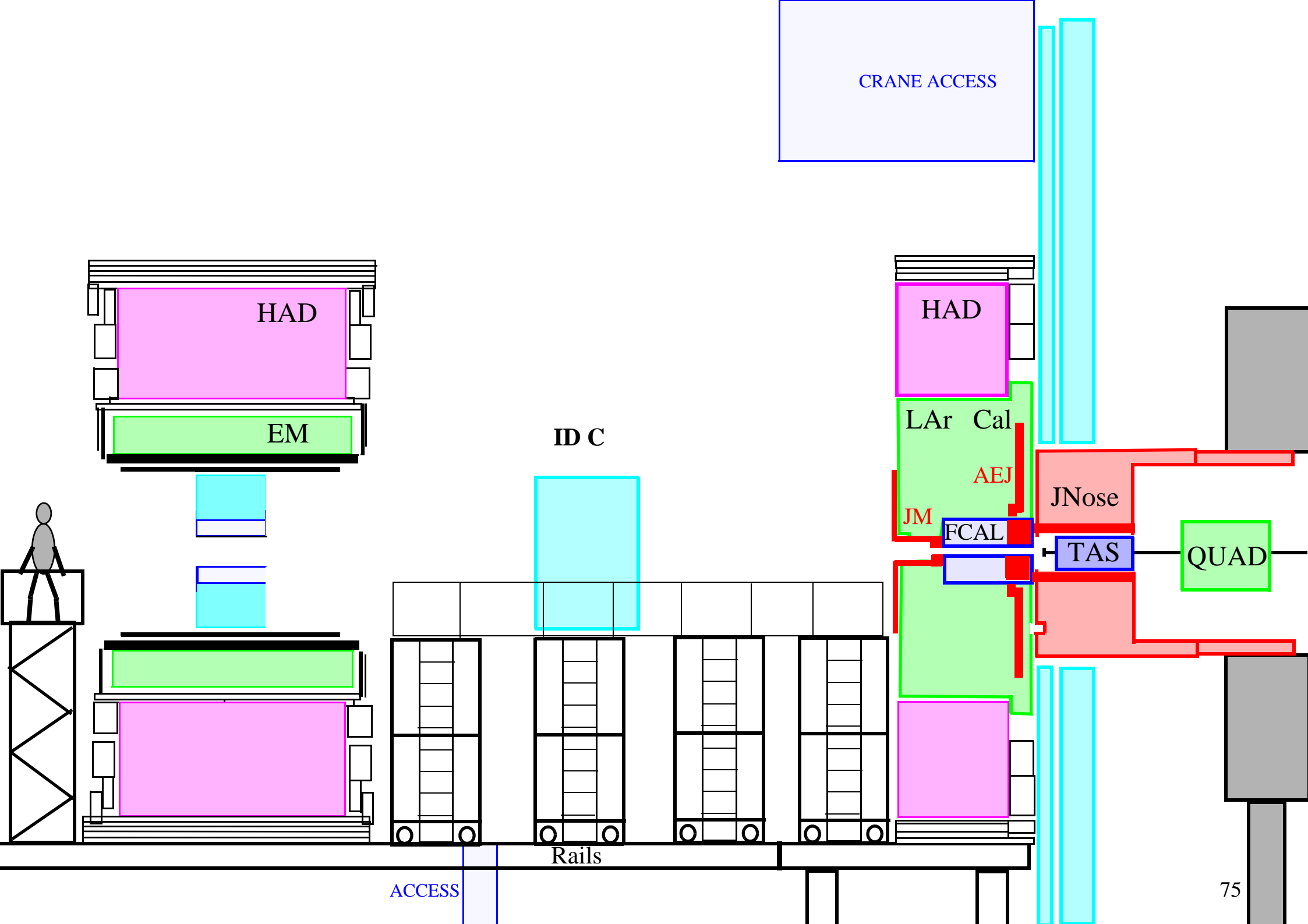

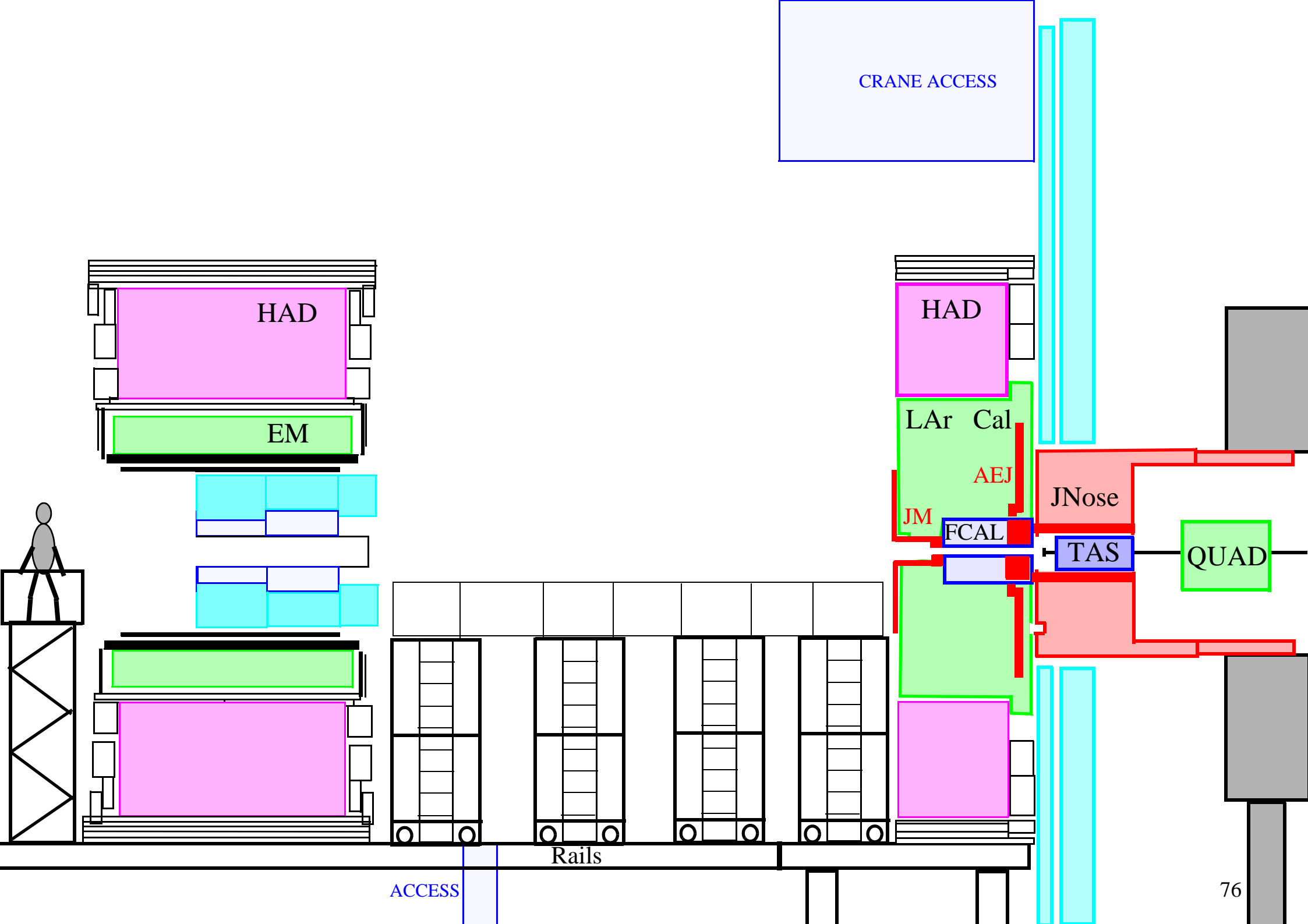

CRANE ACCESS

HAD

EM

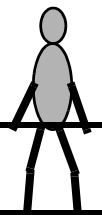

HAD

LAr Cal

AEJ

JM

FCAL

JNose

TAS

QUAD

Rails

ACCESS

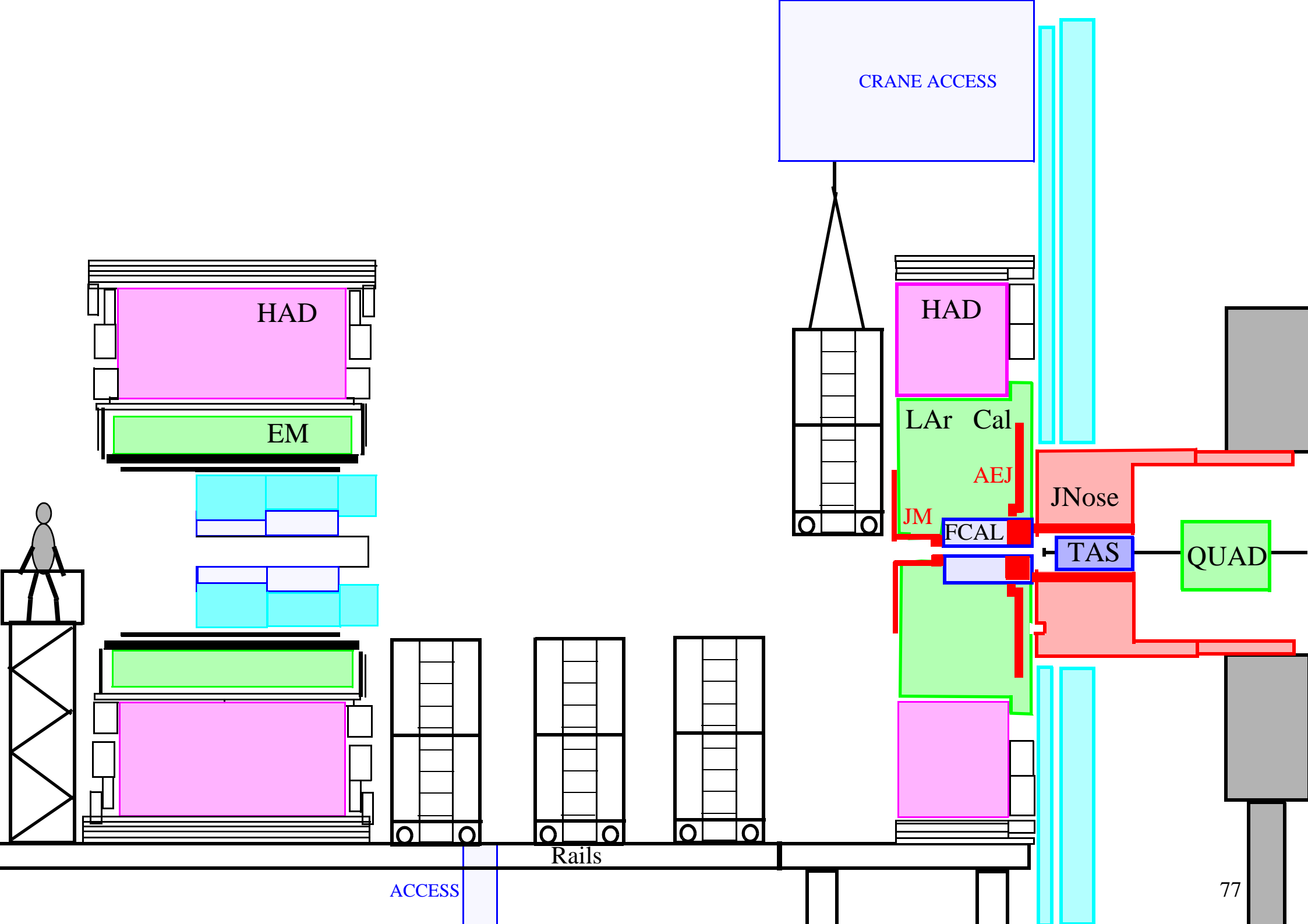

ACCESS

Rails

CRANE ACCESS

HAD

EM

HAD

LAr Cal

AEJ

JM

FCAL

JNose

TAS

QUAD

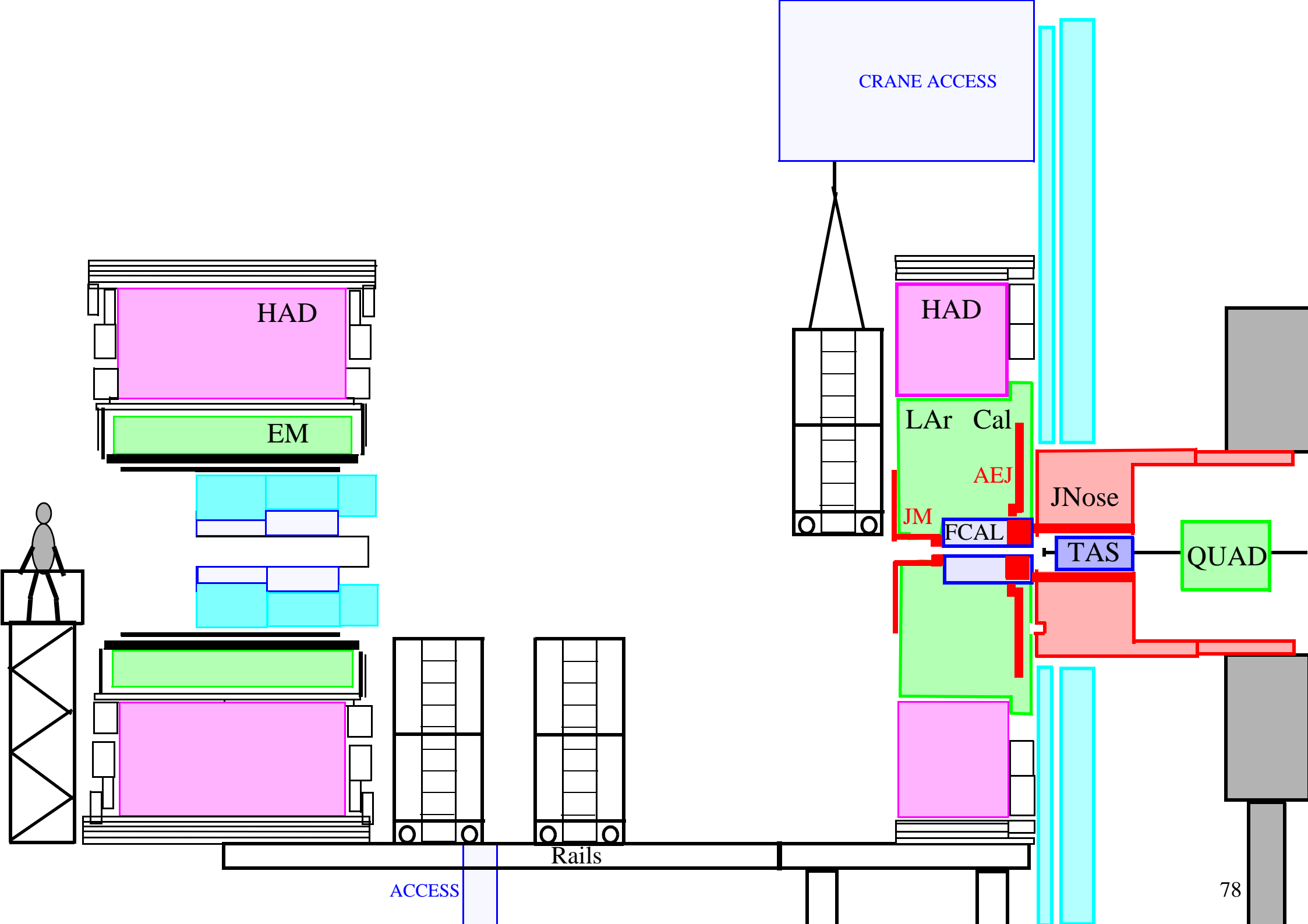

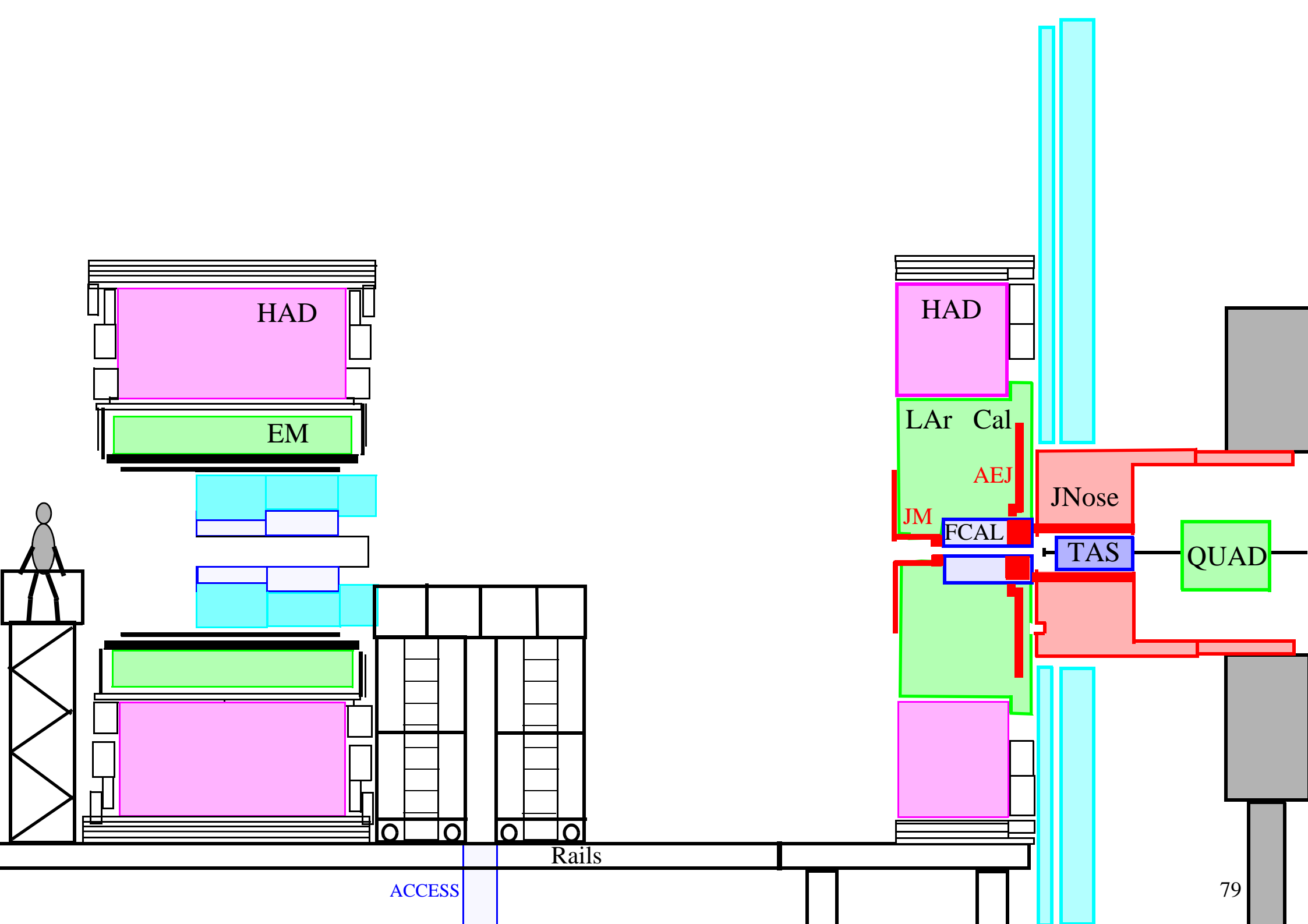

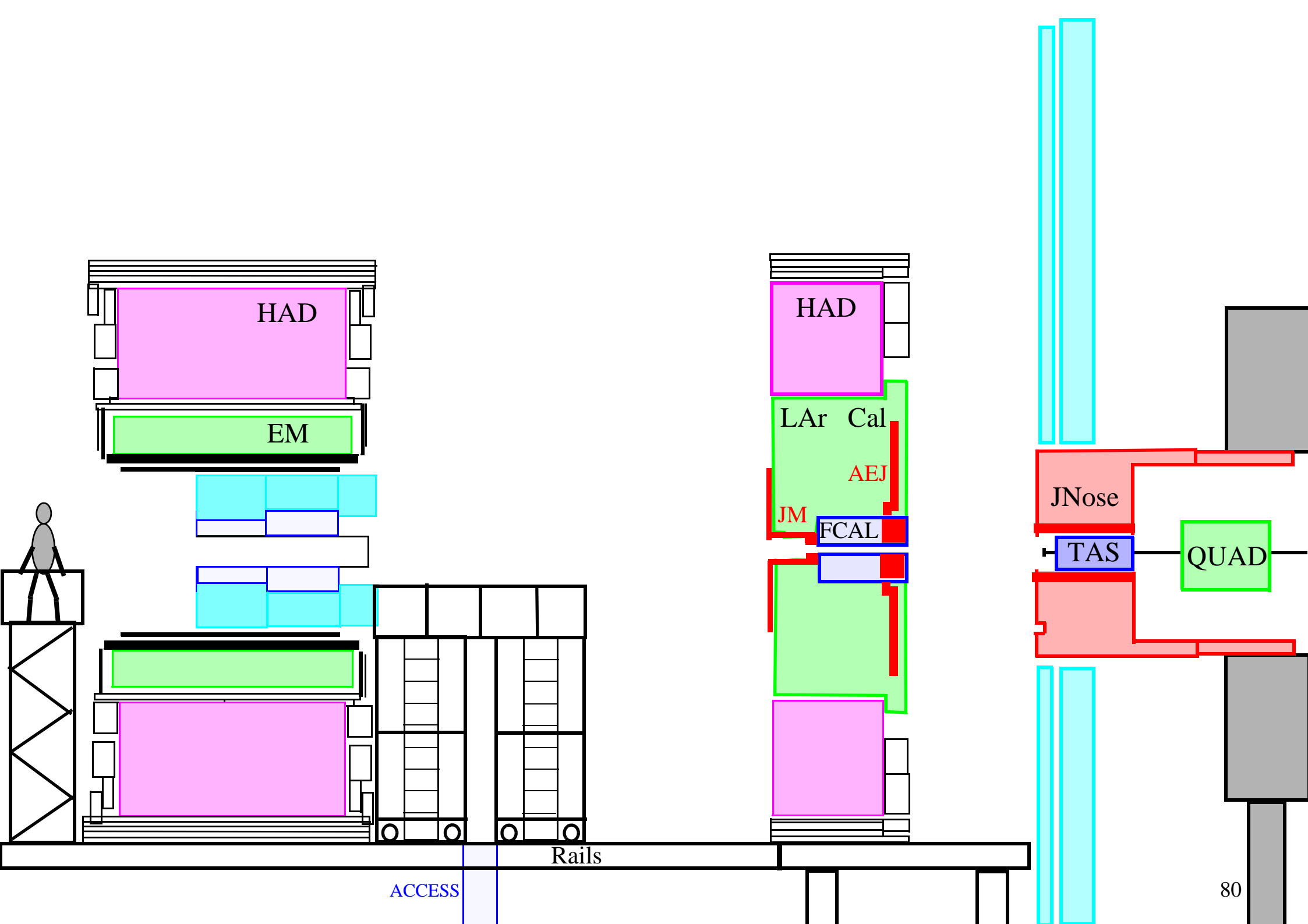

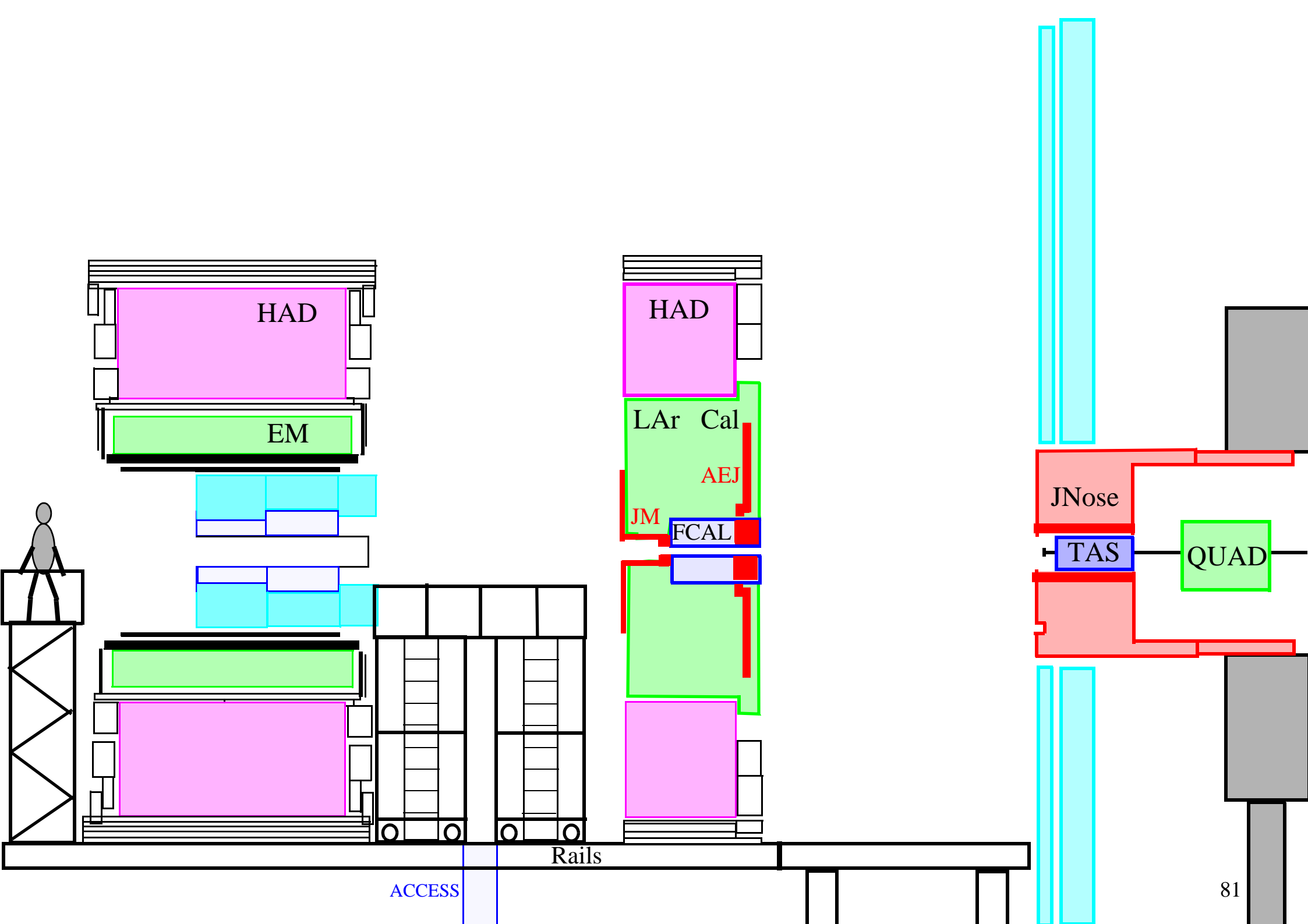

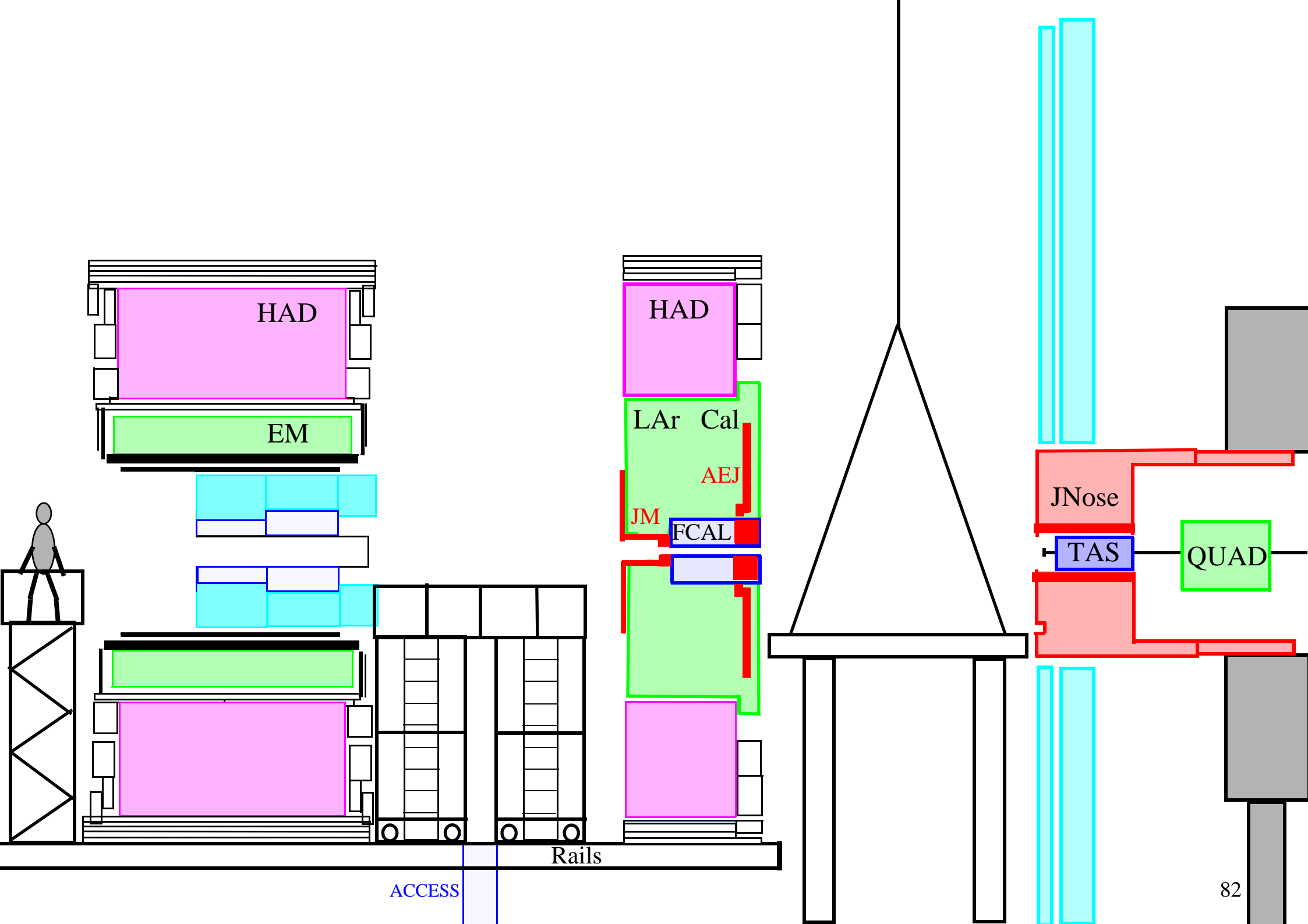

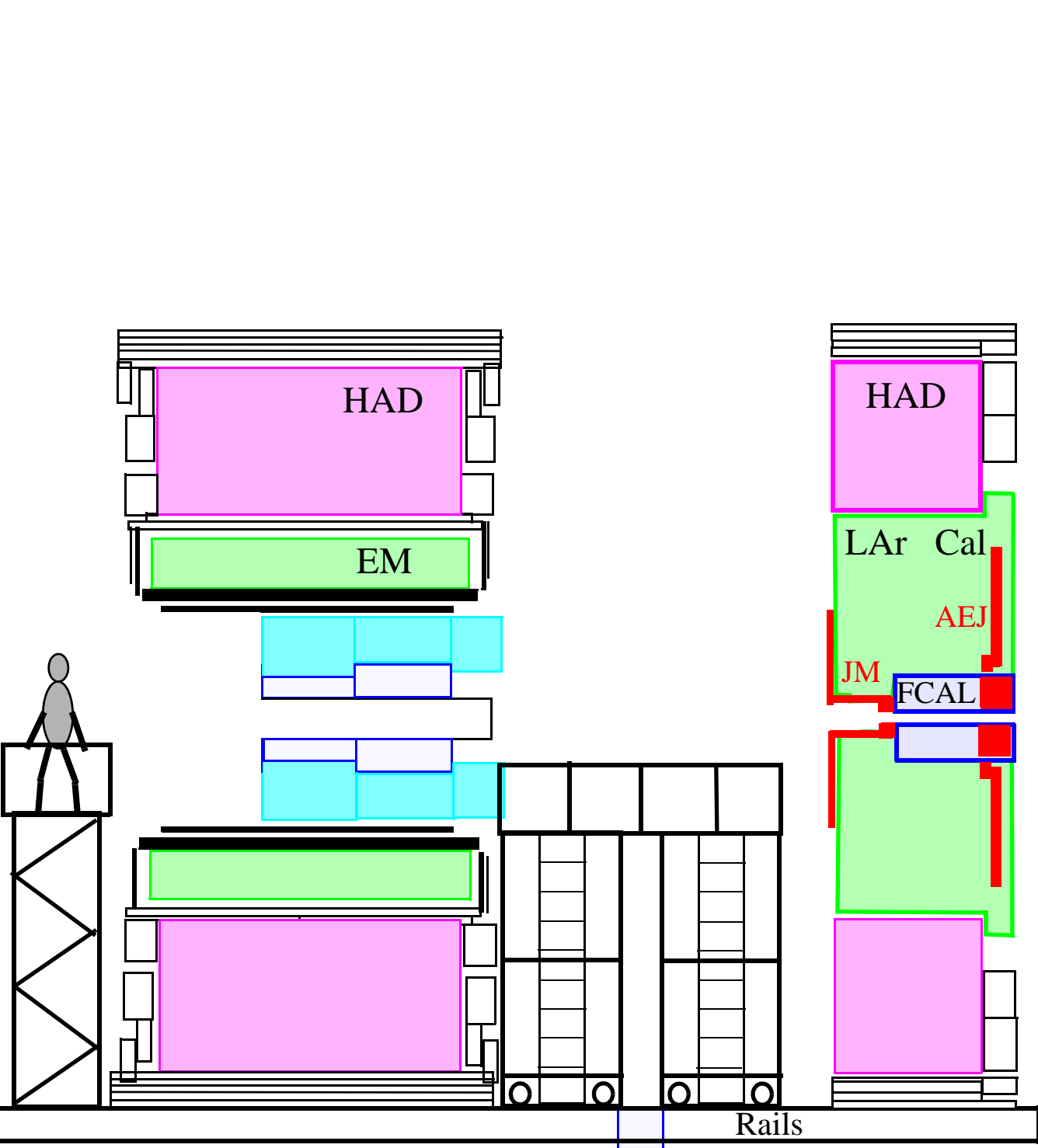

ACCESS

Rails

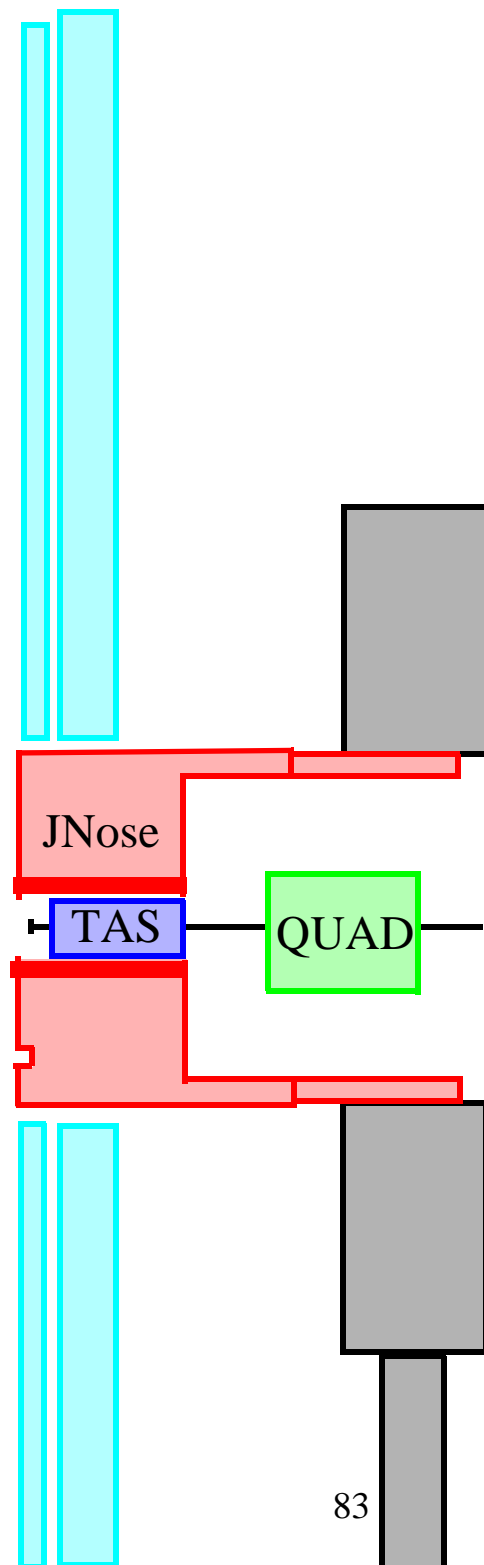

October 2006

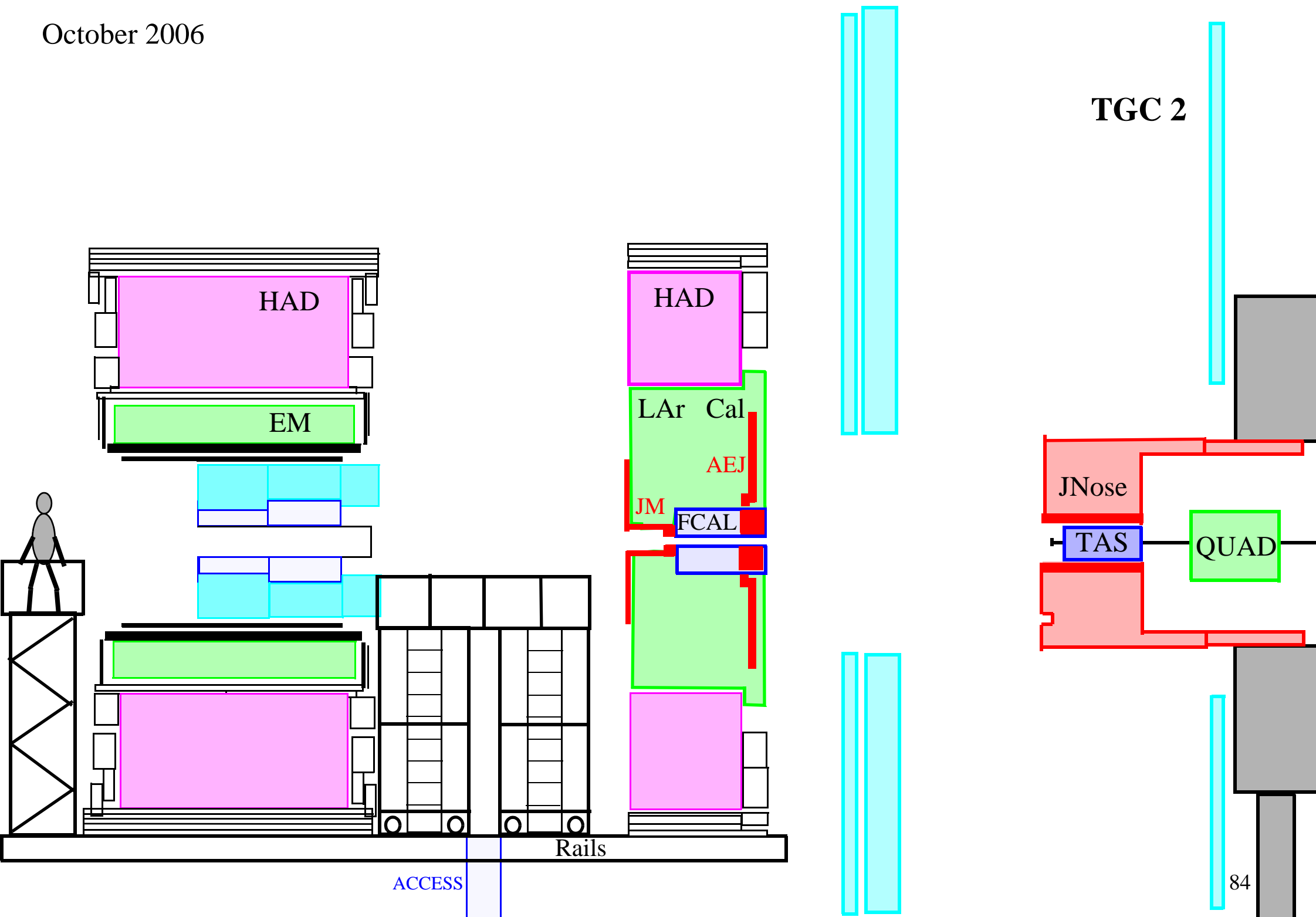

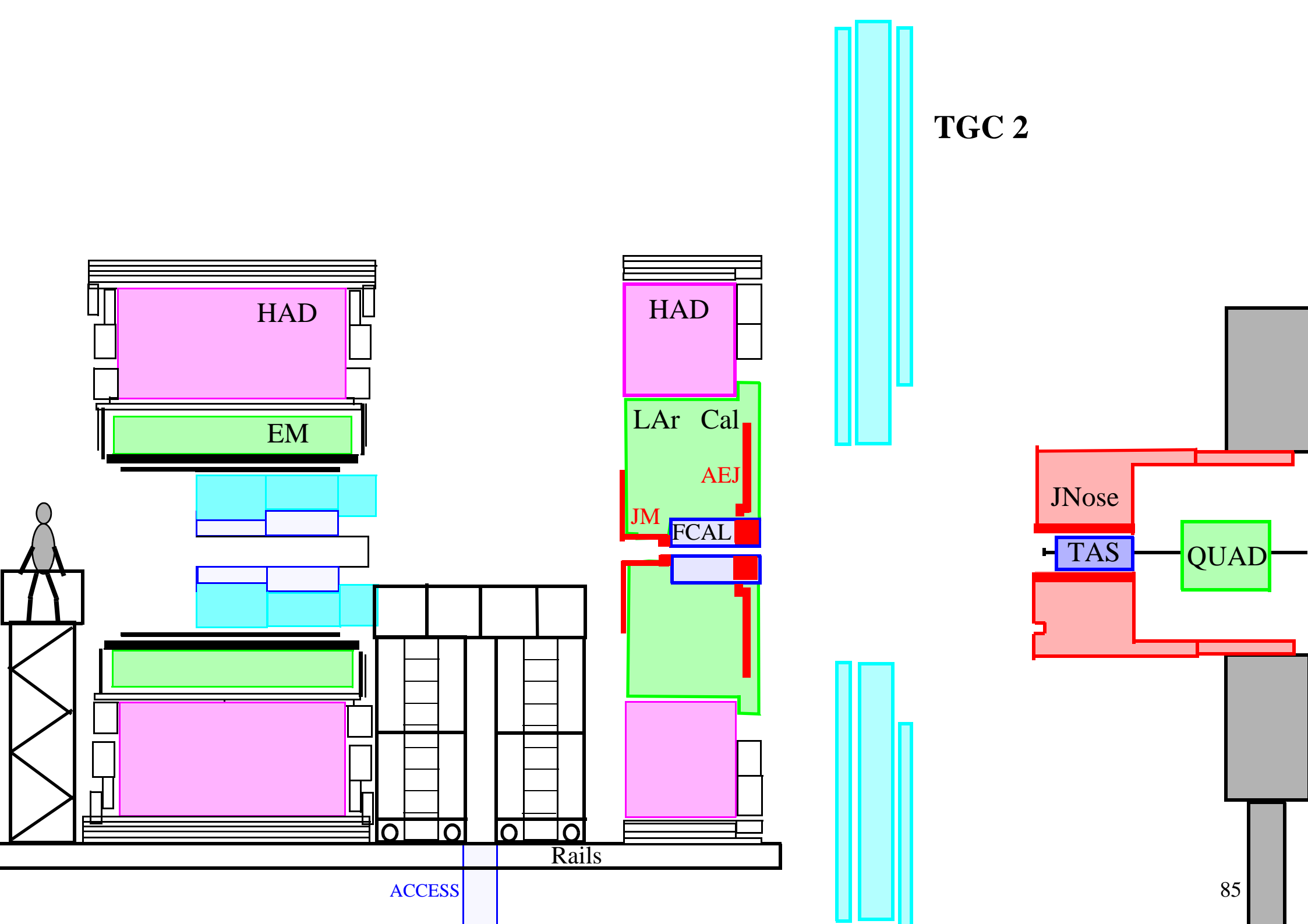

HAD

EM

HAD

LAr Cal

AEJ

JM

FCAL

TGC 2

JNose

TAS

QUAD

Rails

ACCESS

November 2006

ID Endcap A is installed.

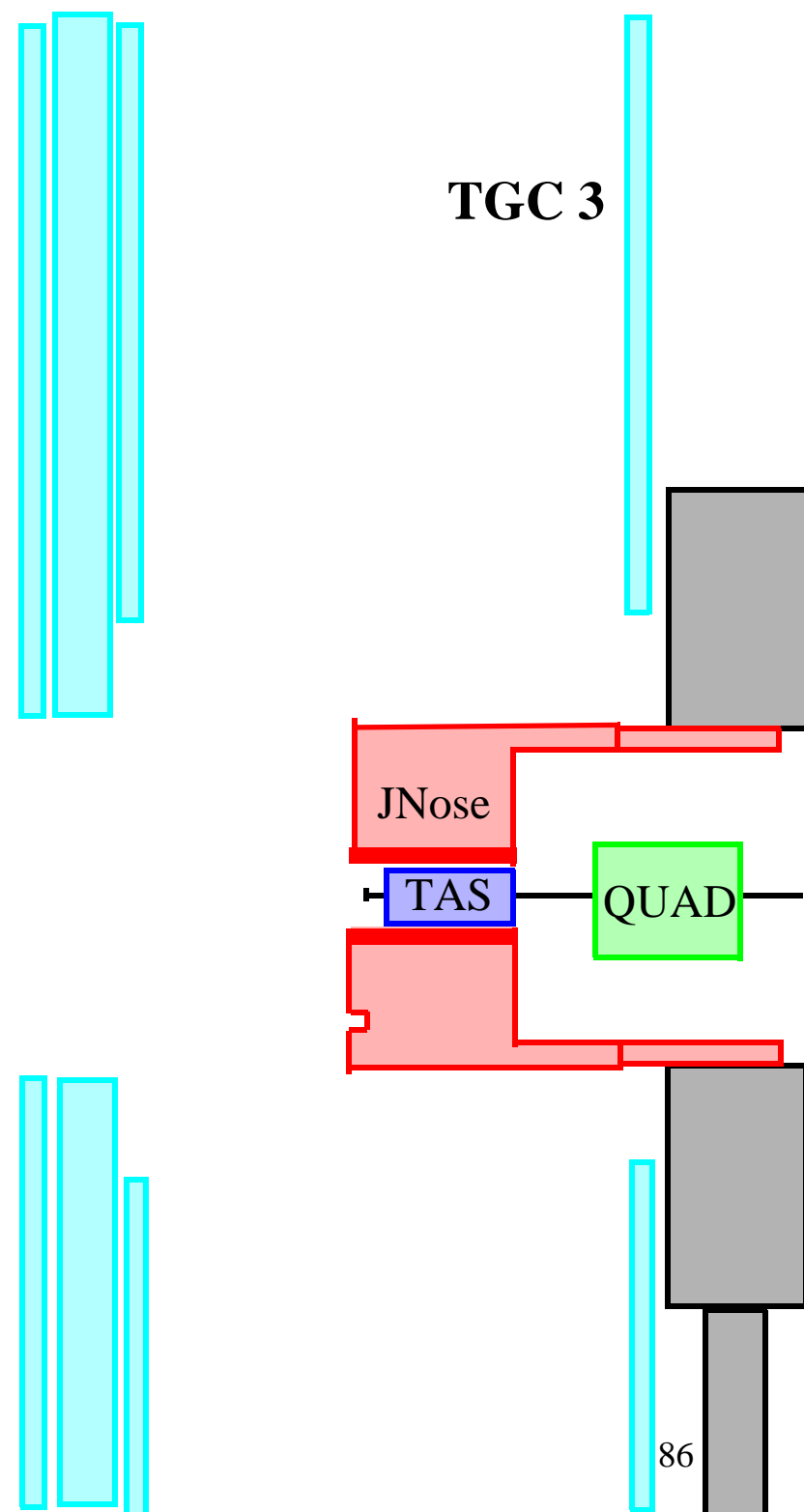
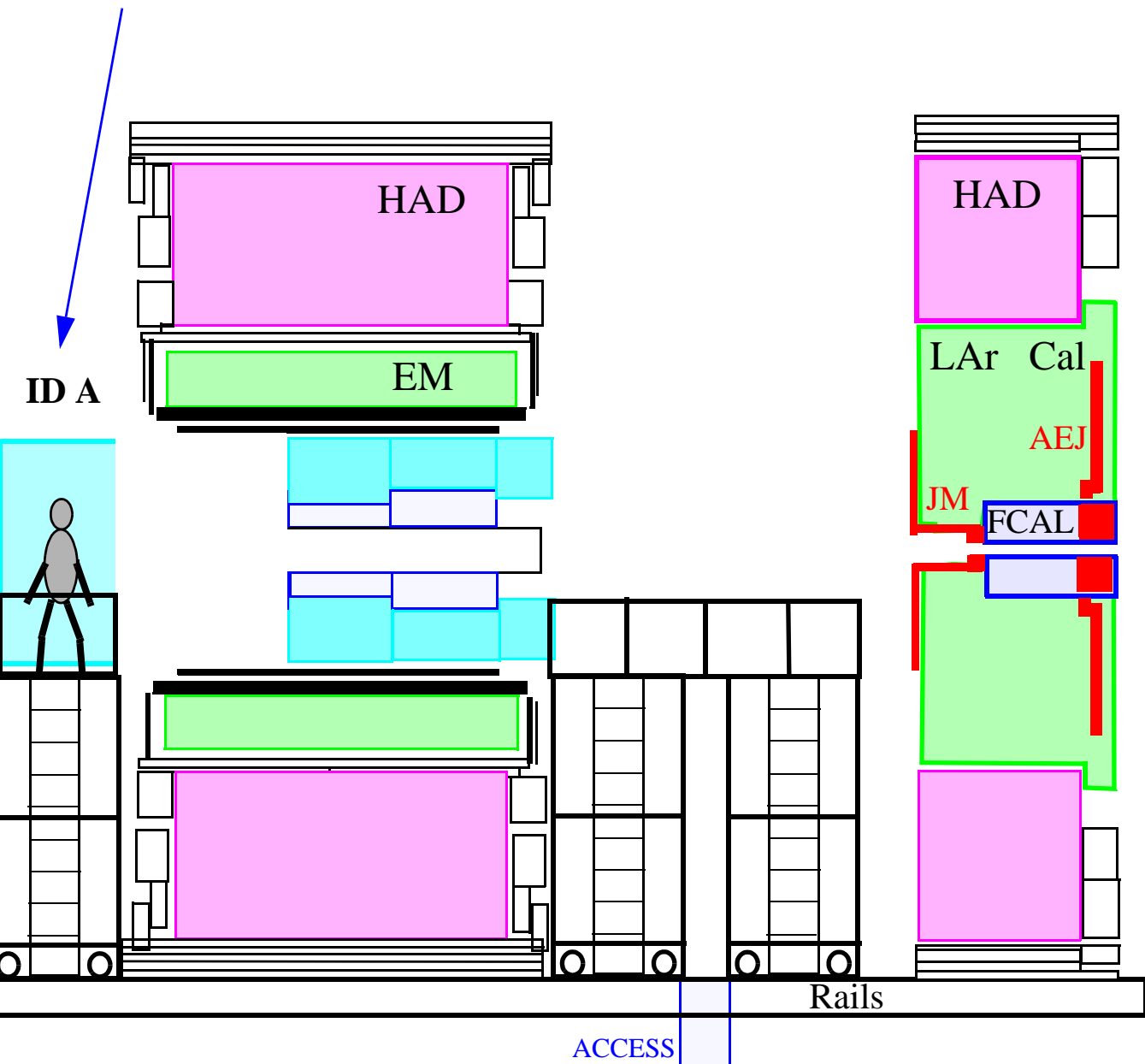

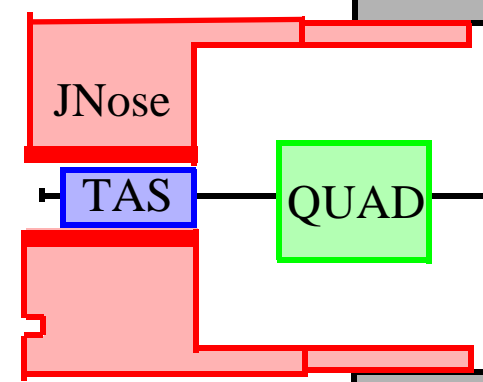
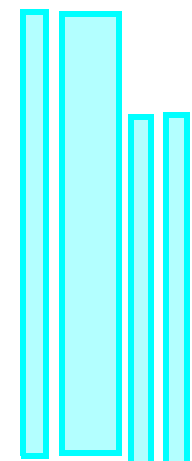
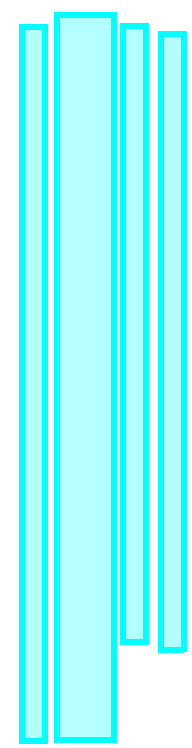
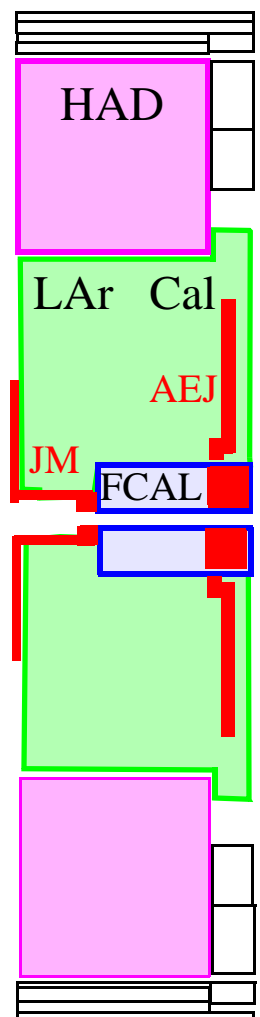
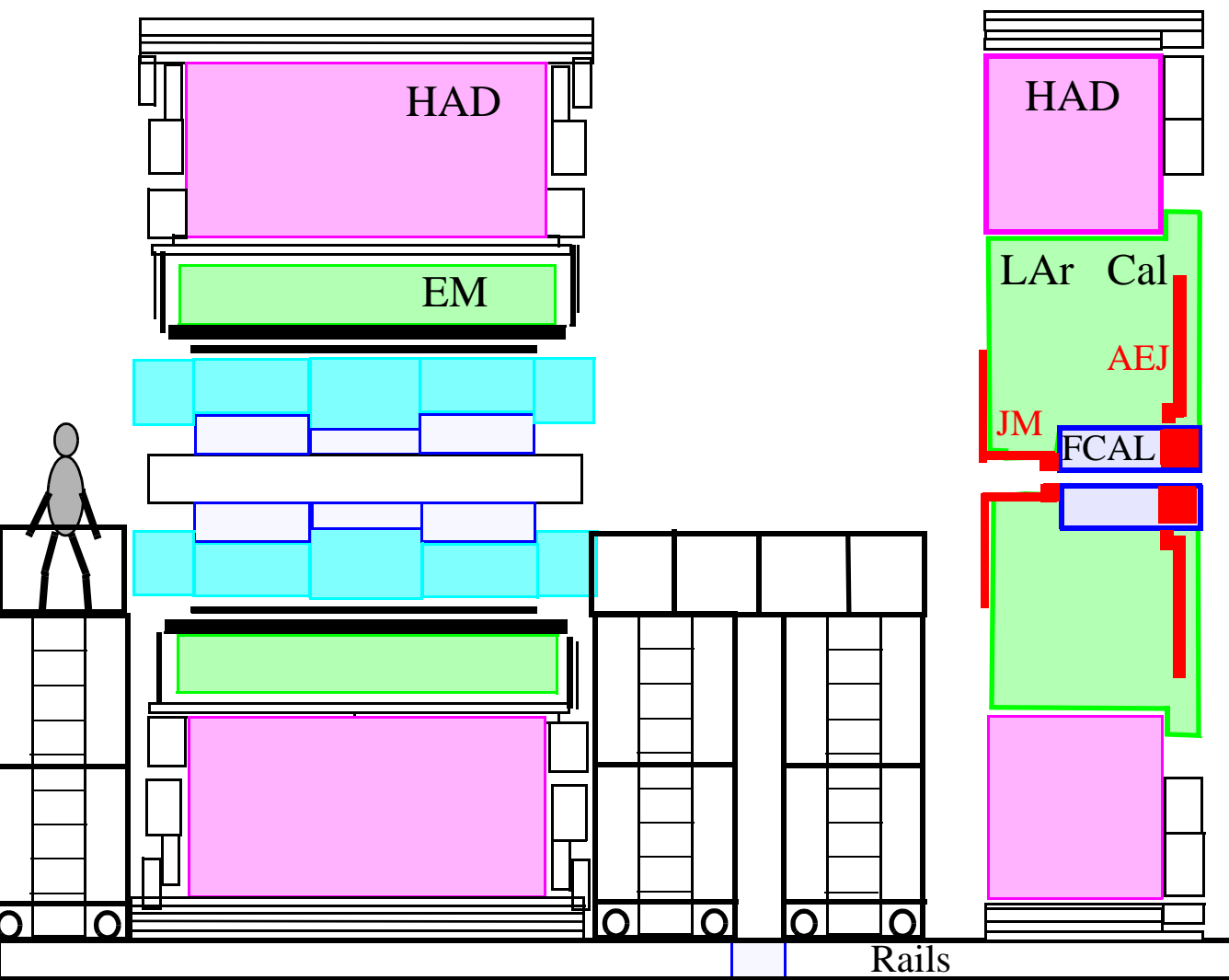

Is this the right time to install the washers ?

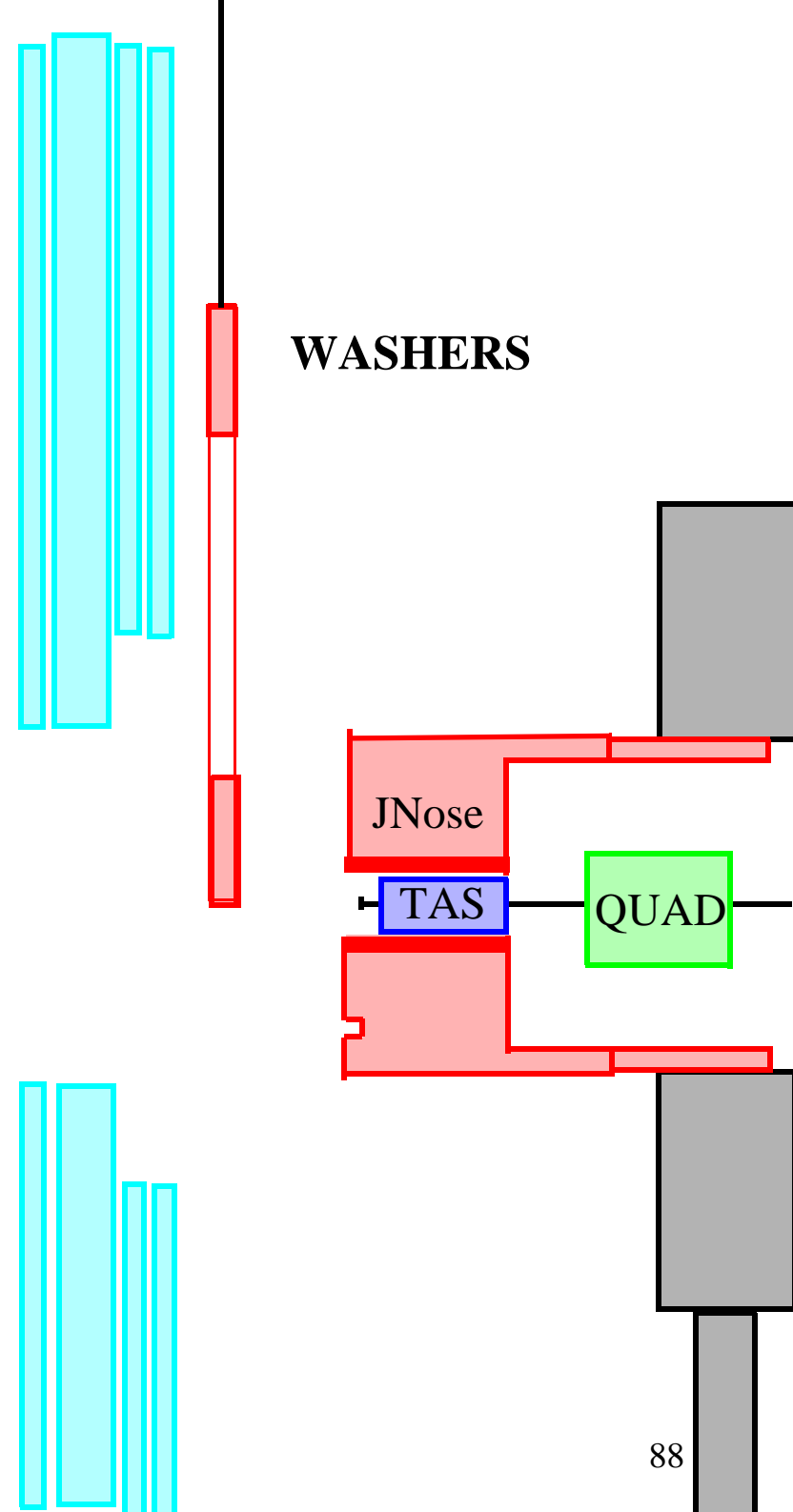
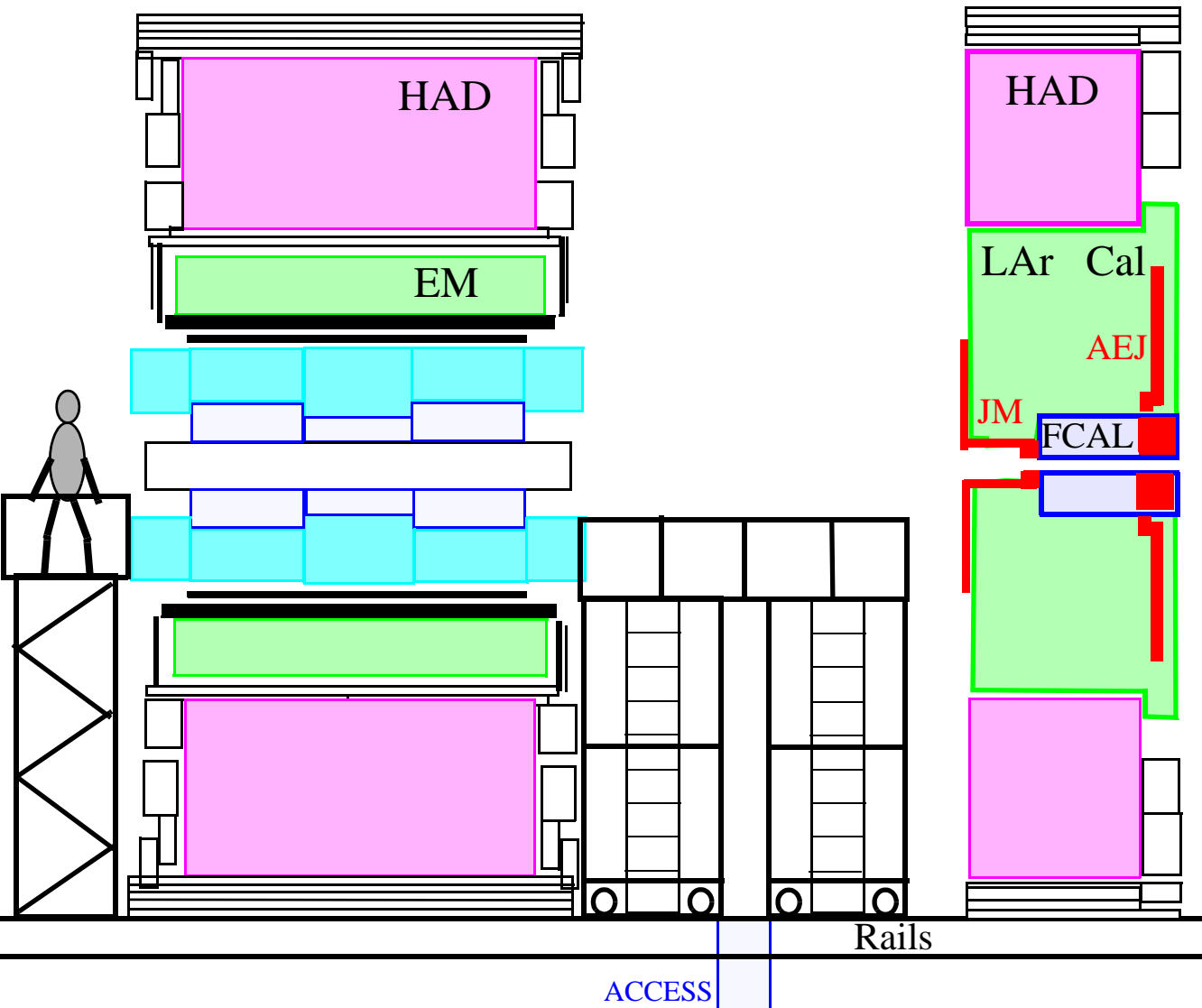

WASHERS

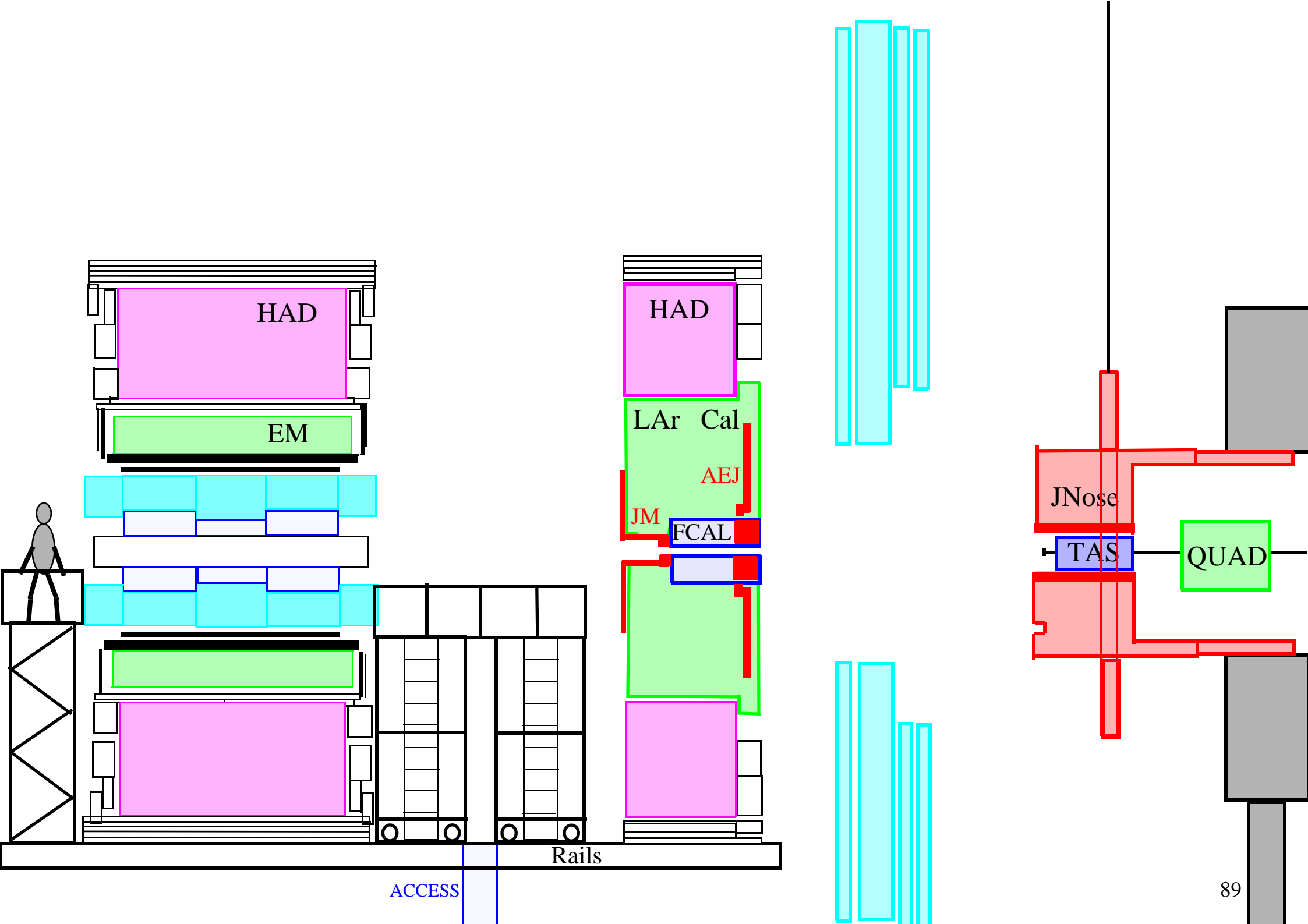

HAD

EM



HAD

LAr Cal

AEJ

JM

FCAL

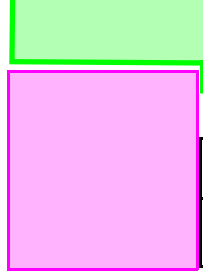
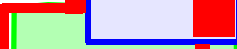

Rails

ACCESS

JNose

TAS

QUAD

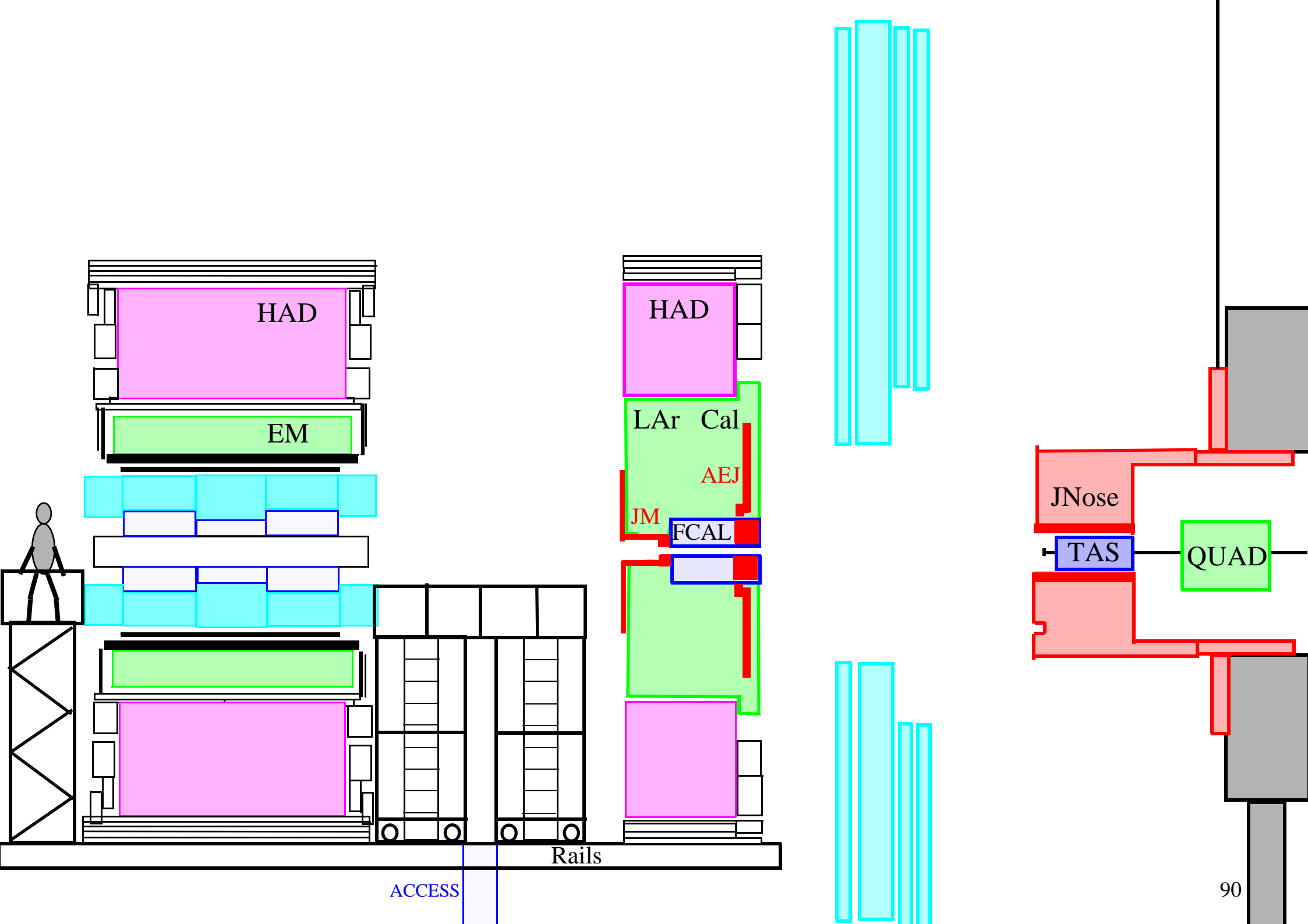

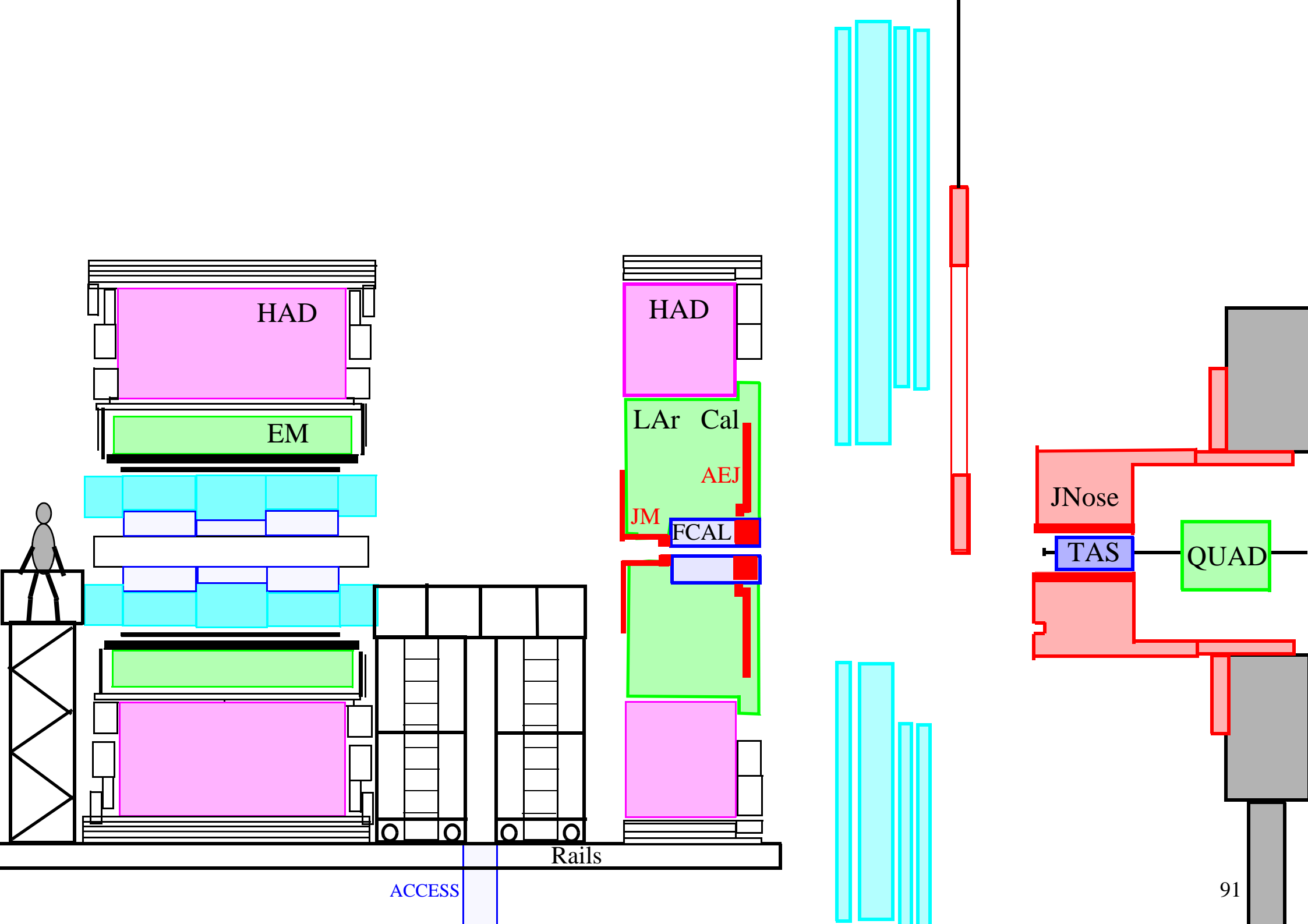

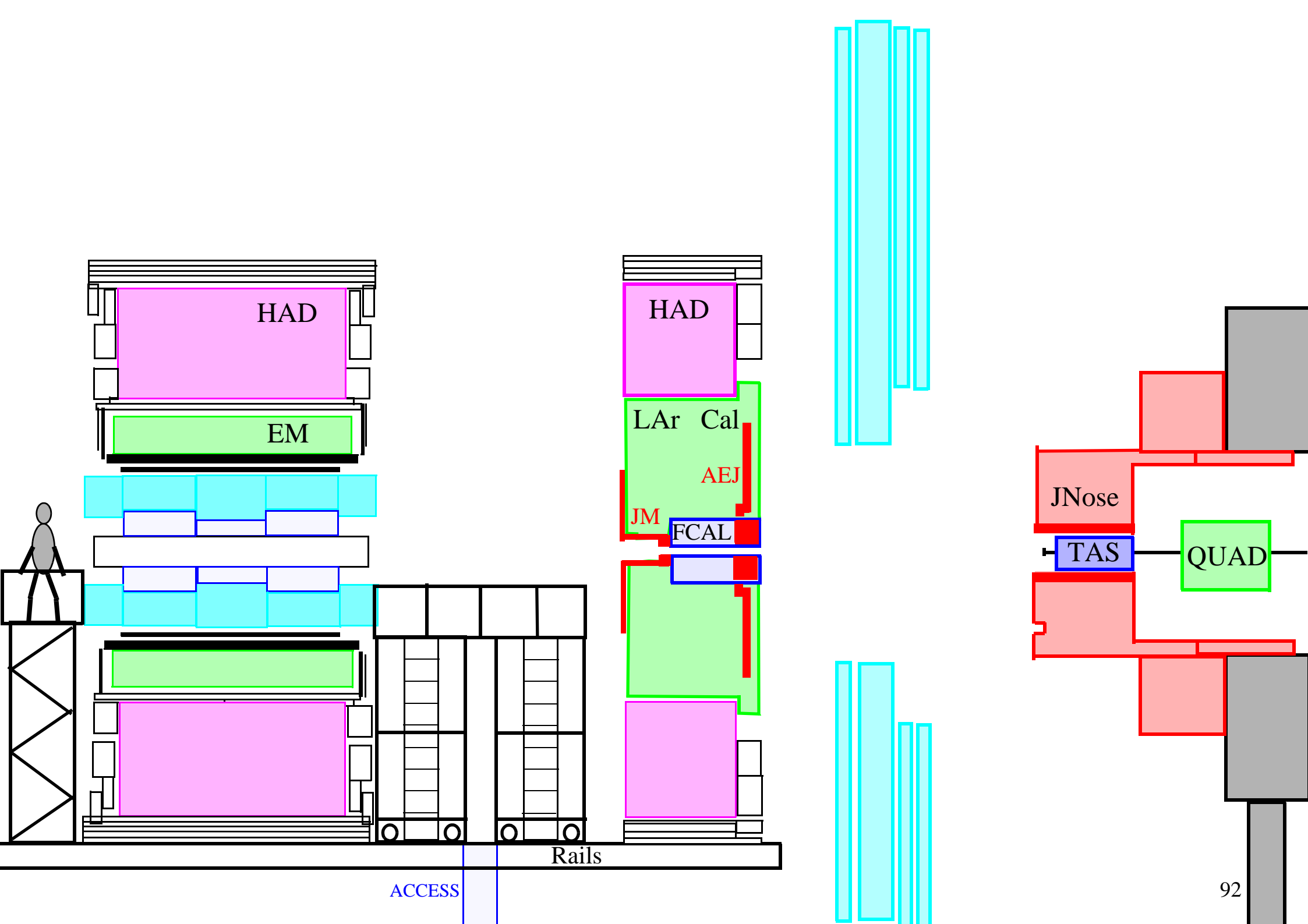

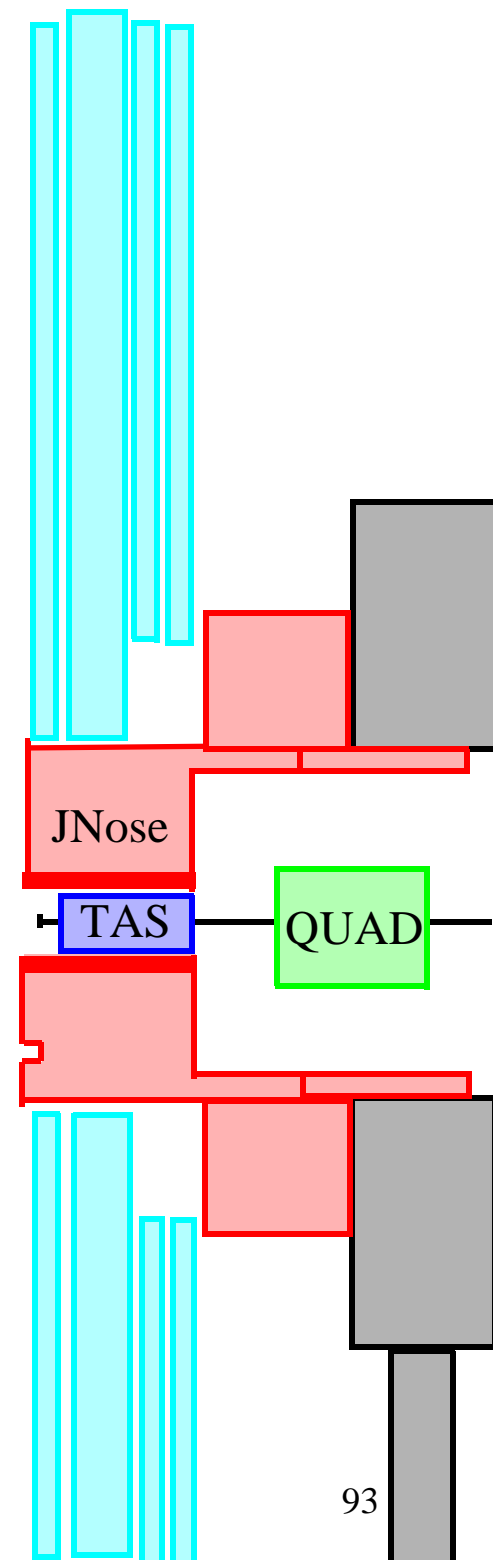
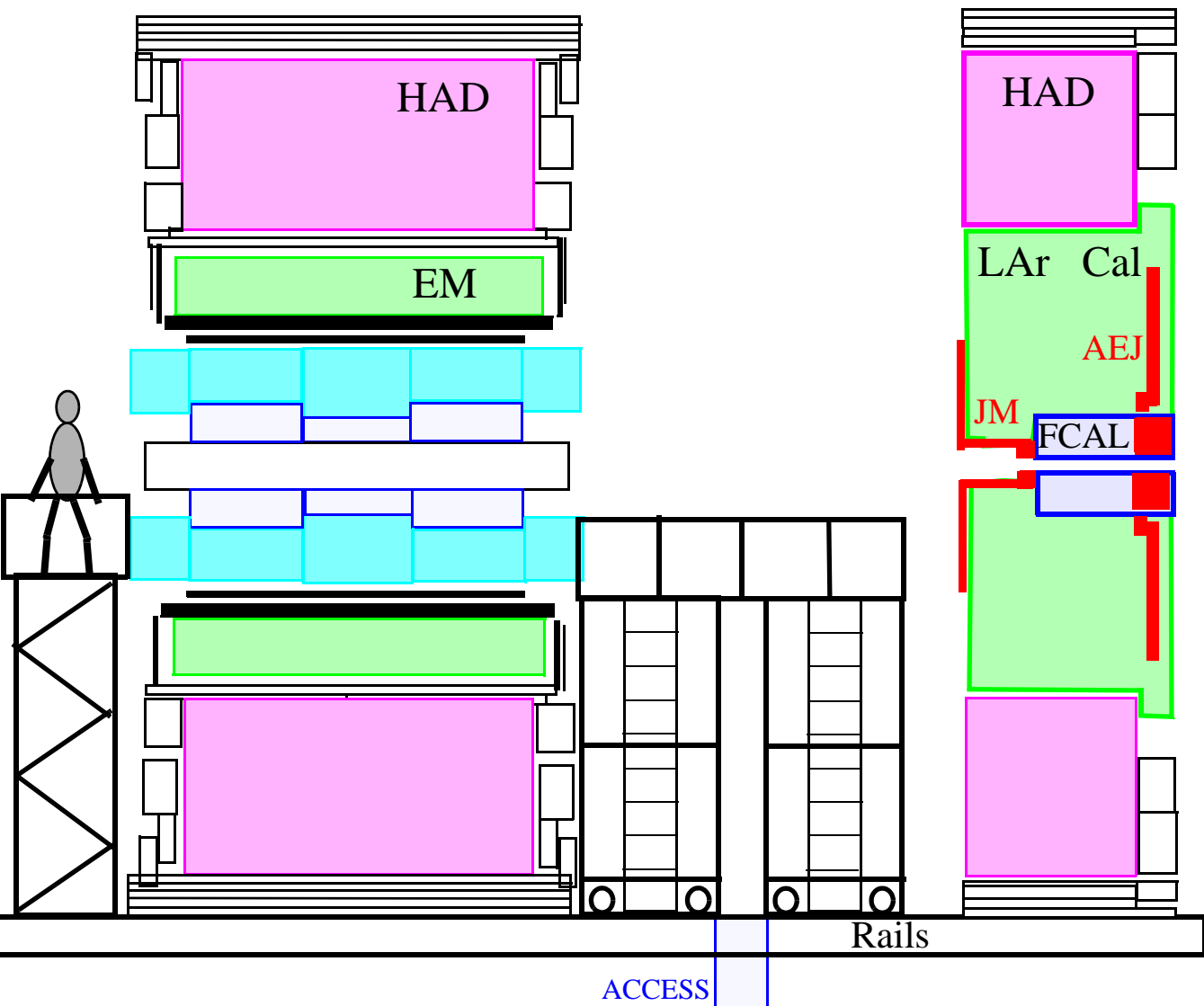

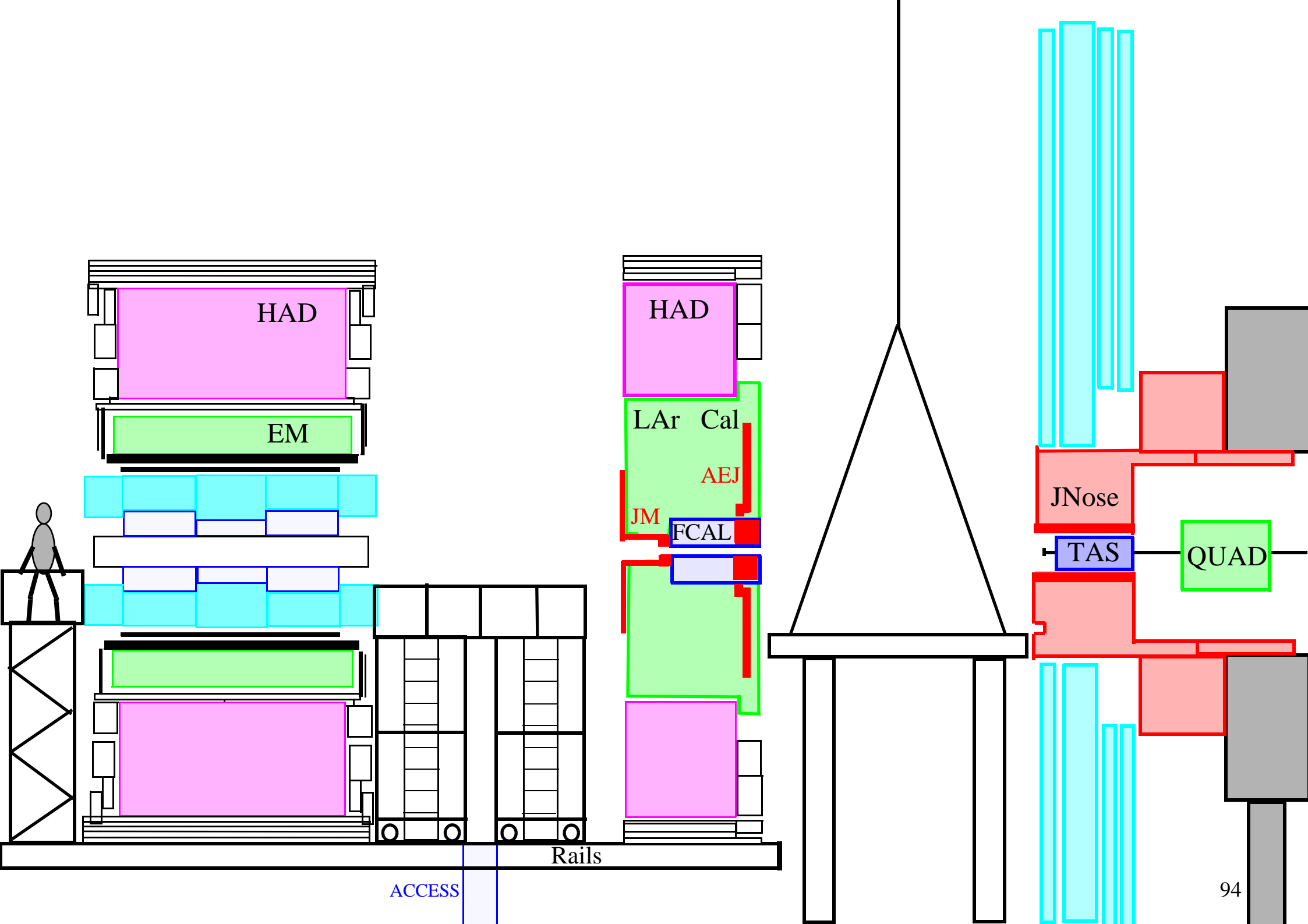

HAD

EM



HAD

LAr Cal

AEJ

JM

FCAL

Rails

ACCESS

JNose

TAS

QUAD

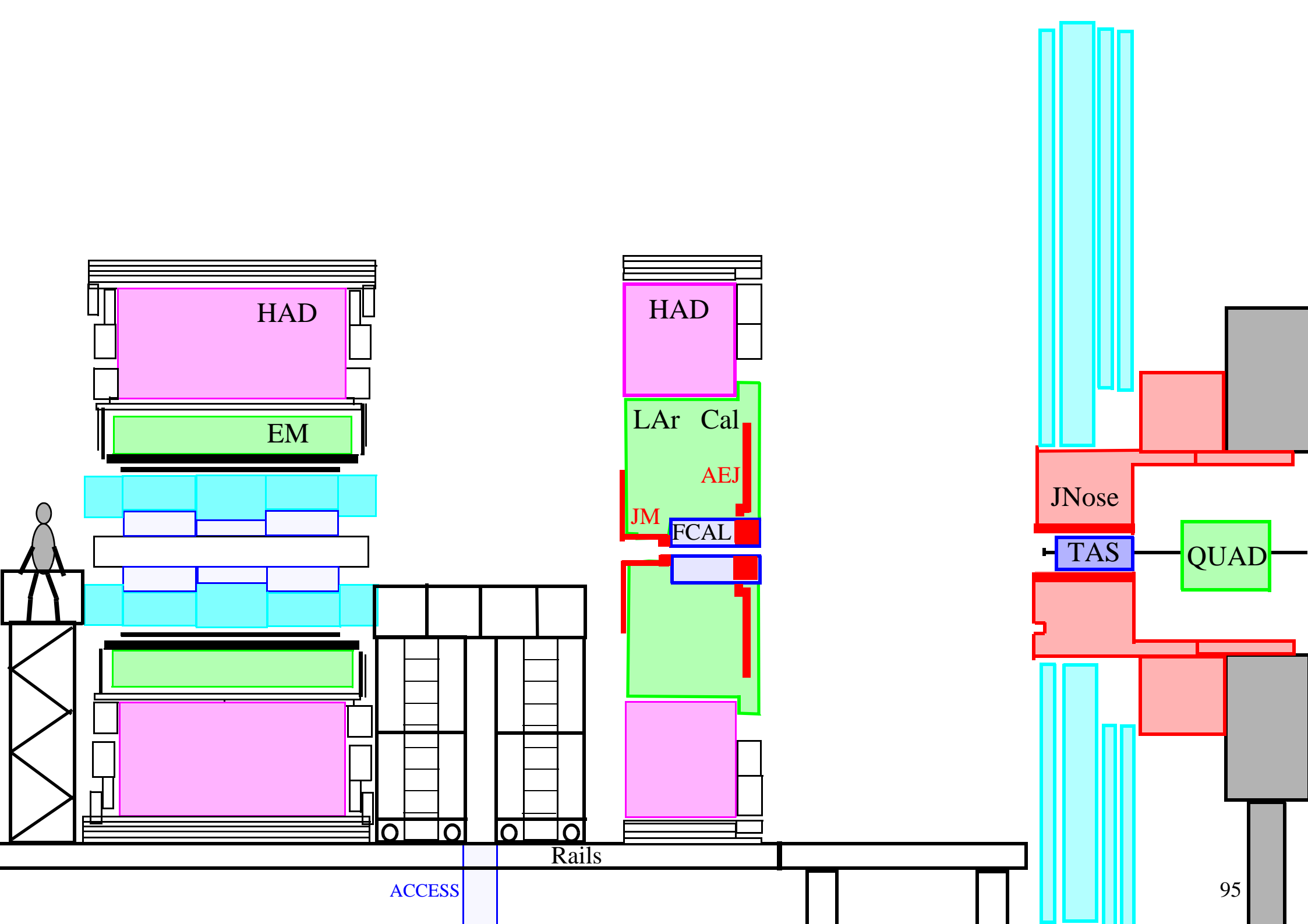

HAD

EM

HAD

HAD

LAr Cal

AEJ

JM

FCAL

JNose

TAS

QUAD

Rails

ACCESS

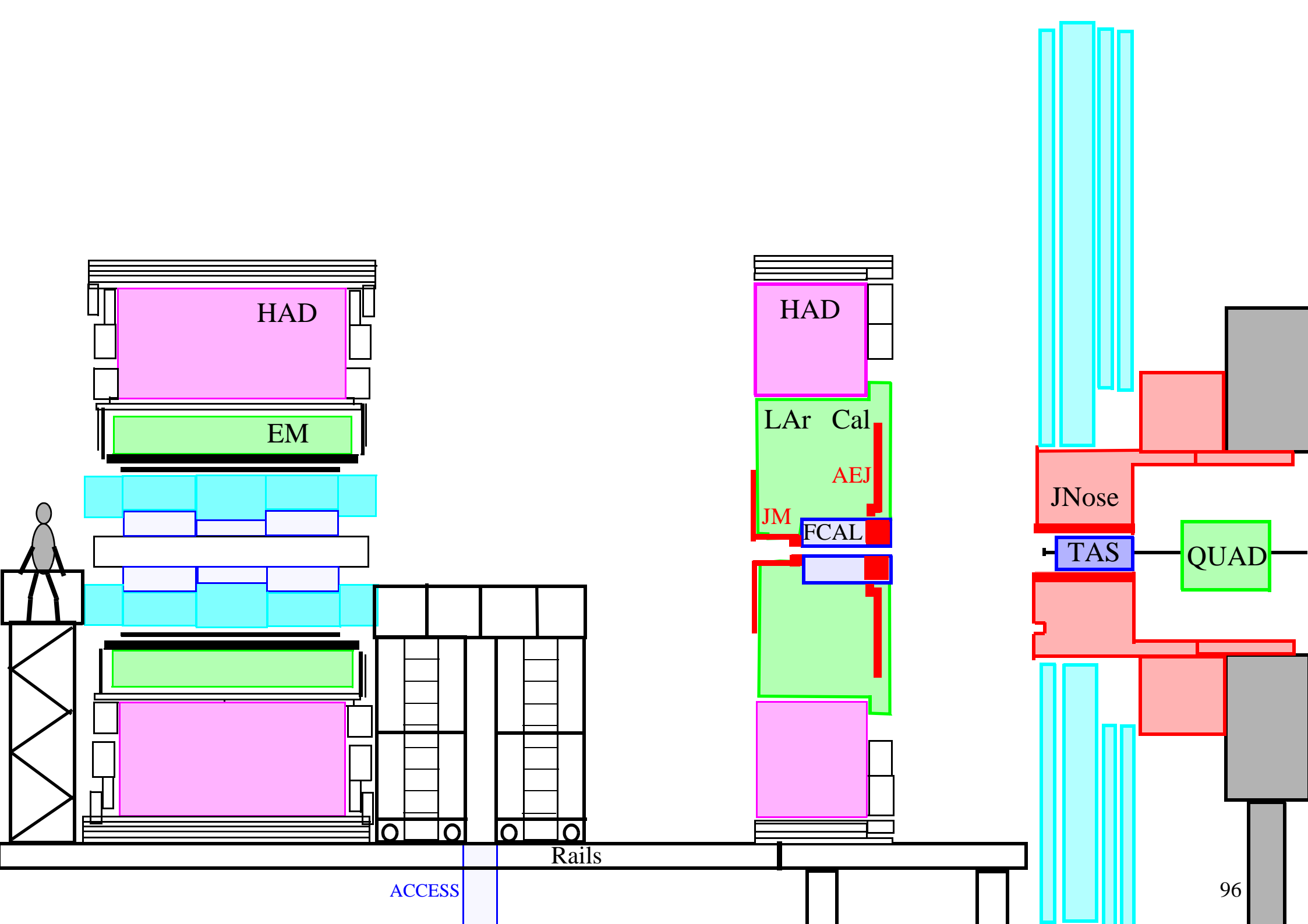

HAD

EM



HAD

LAr Cal

AEJ

JM

FCAL

JNose

TAS

QUAD

Rails

ACCESS

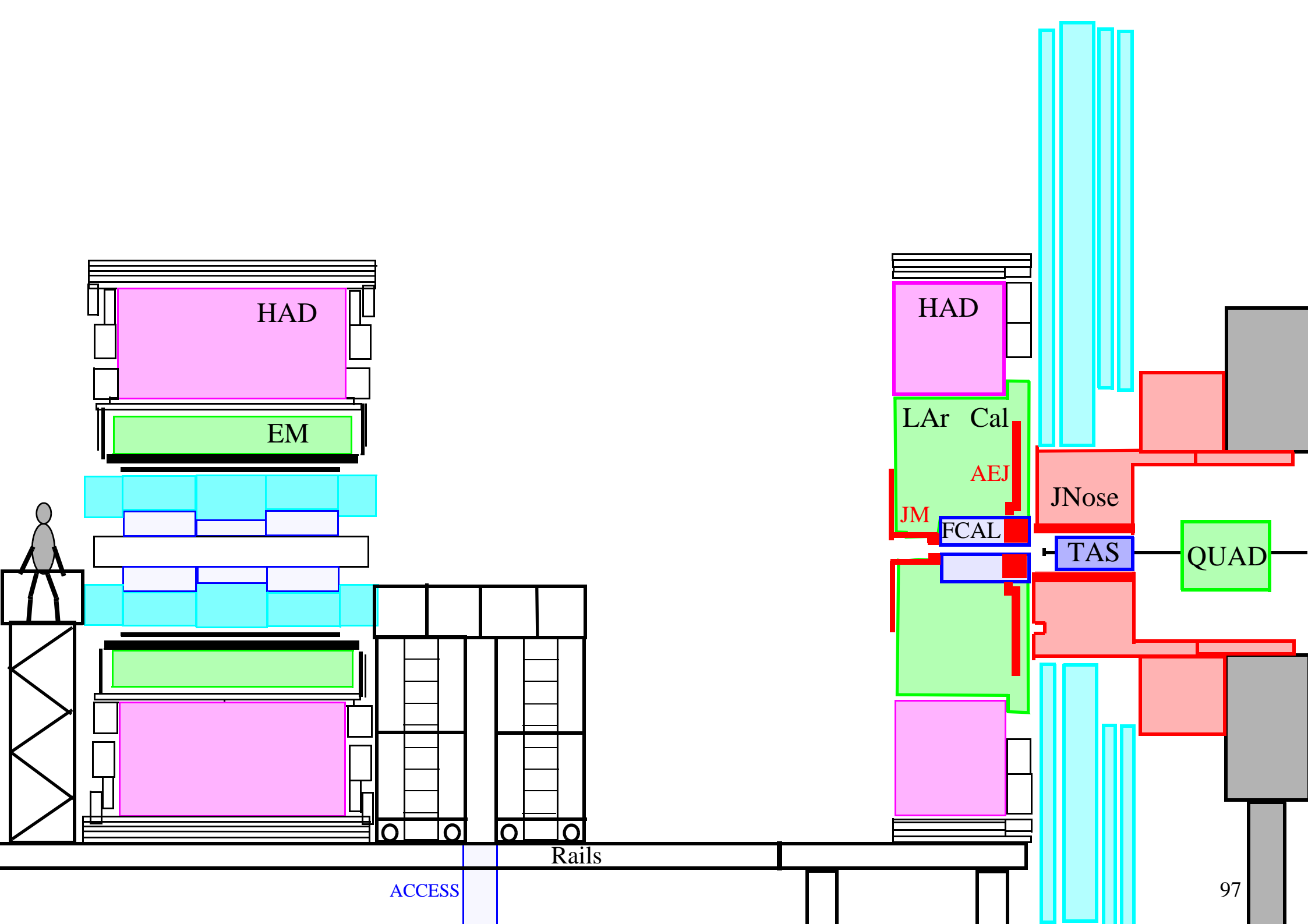

HAD

EM



HAD

LAr Cal

AEJ

JM

FCAL

JNose

TAS

QUAD

Rails

ACCESS

97

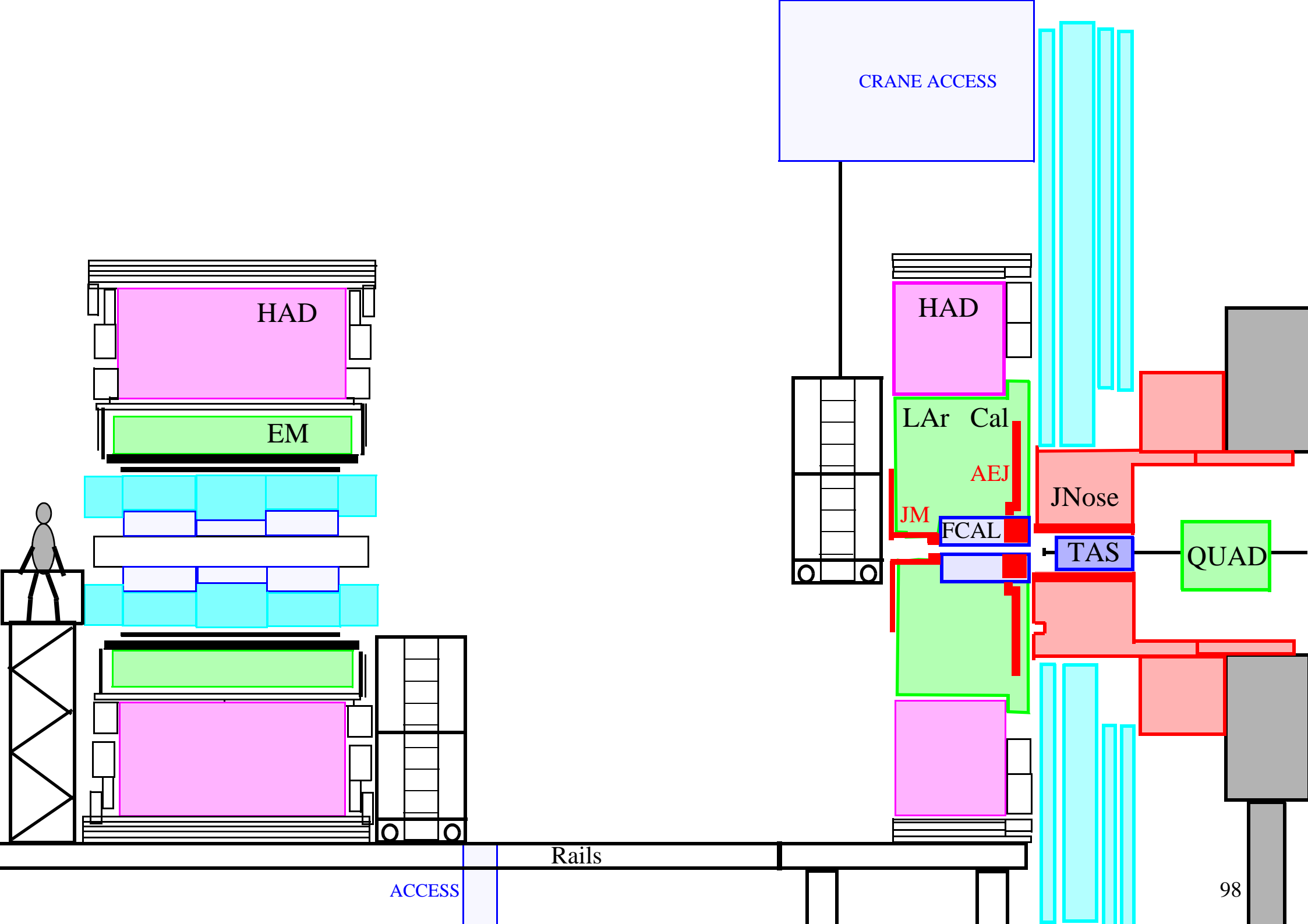

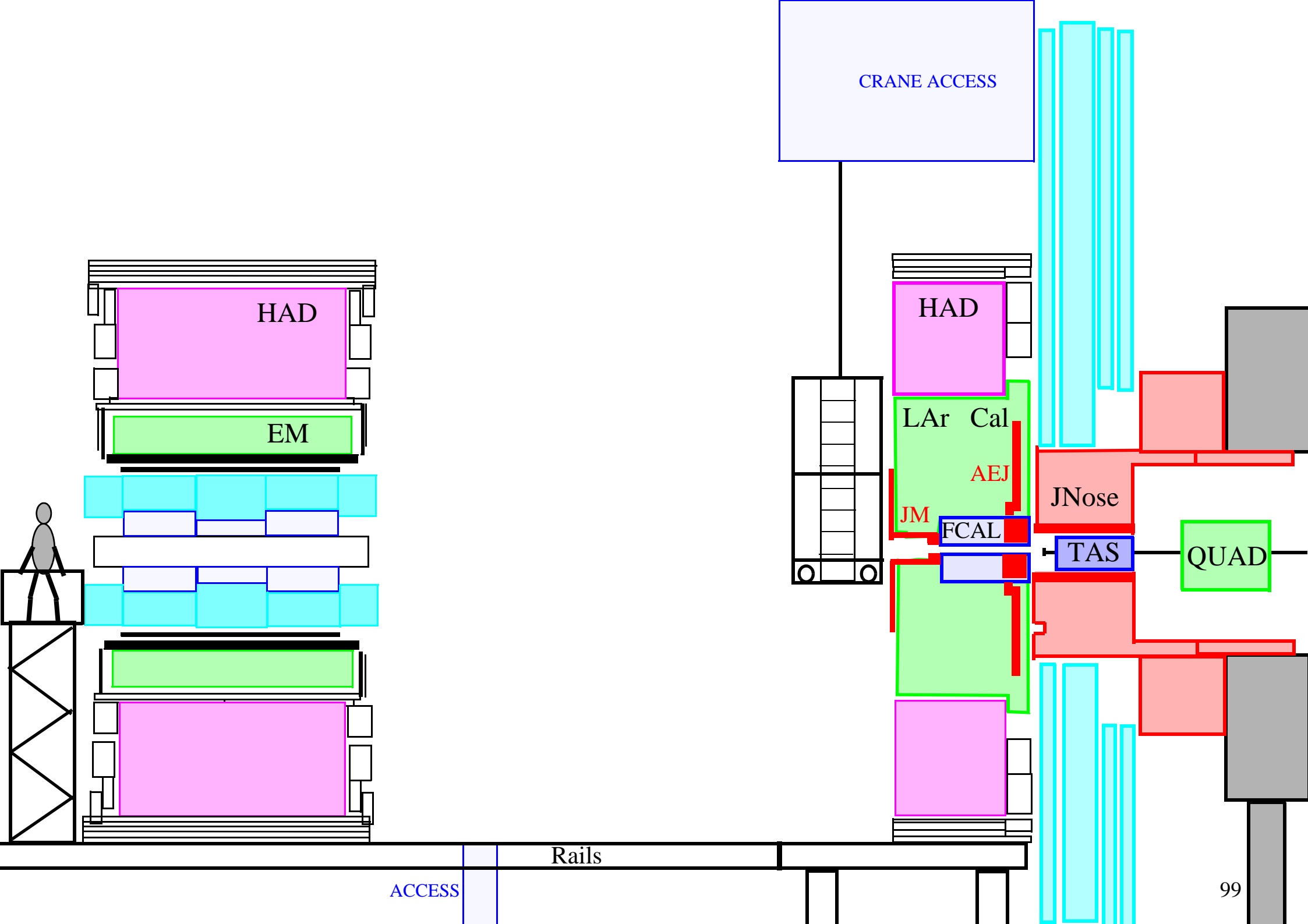

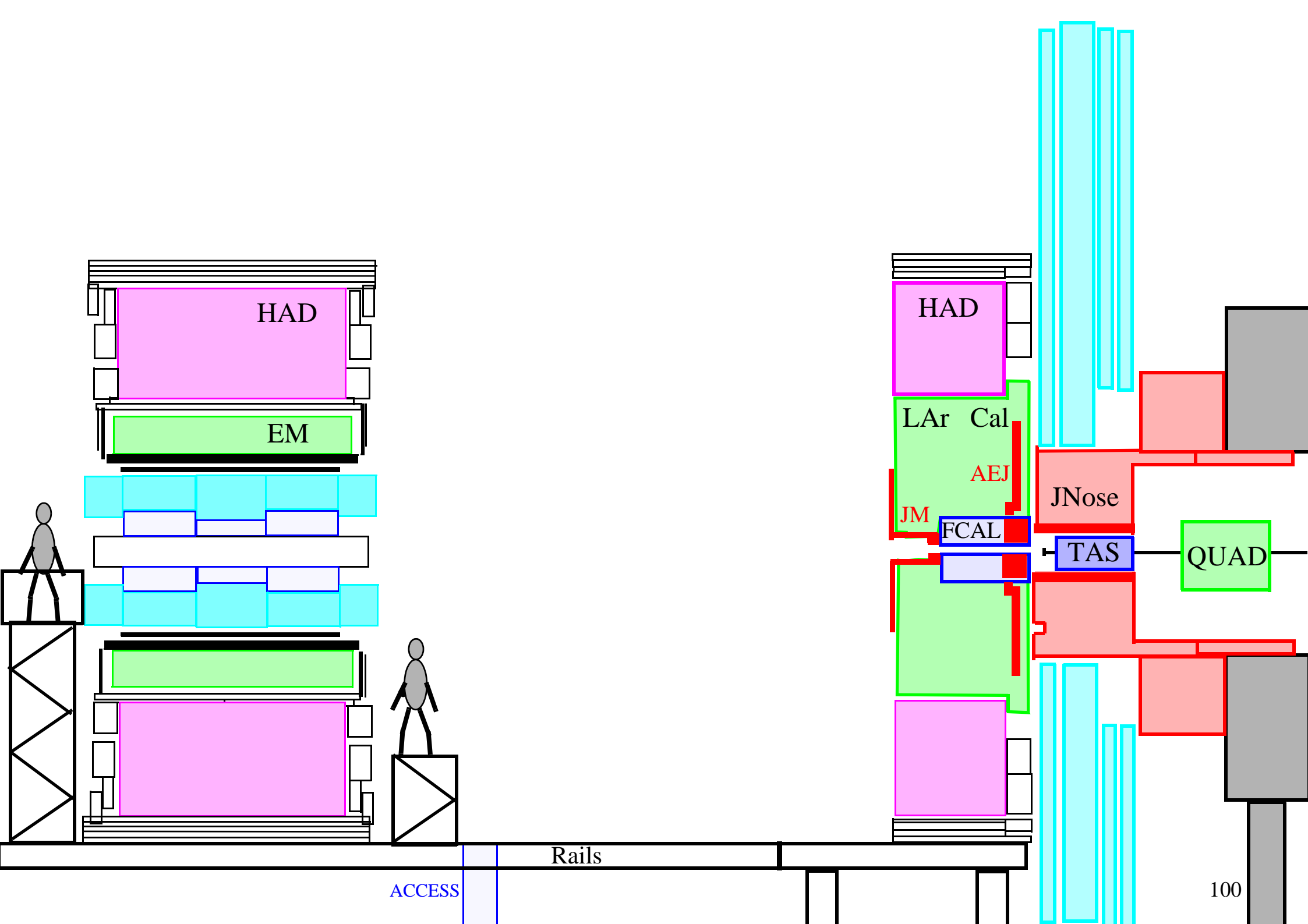

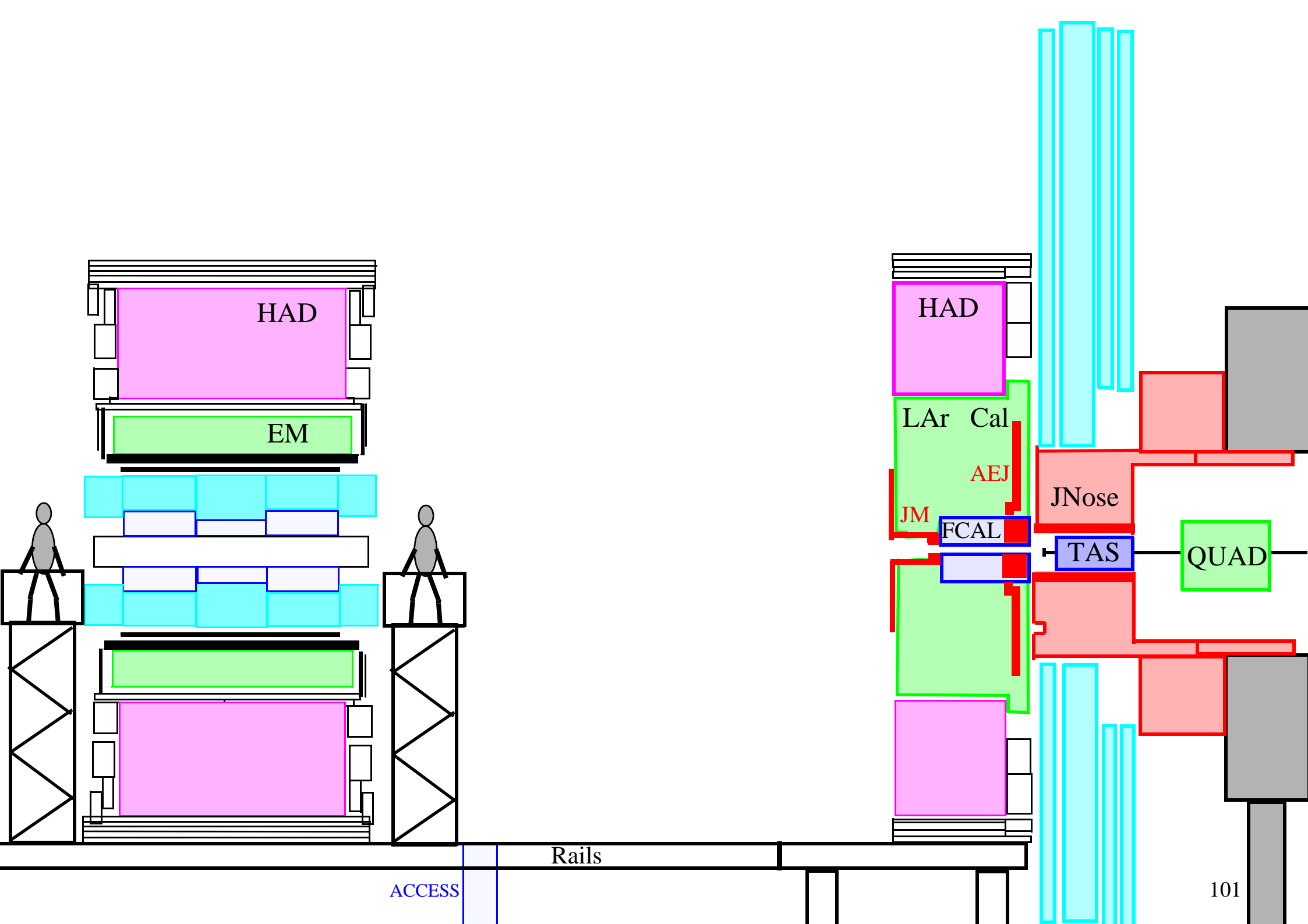

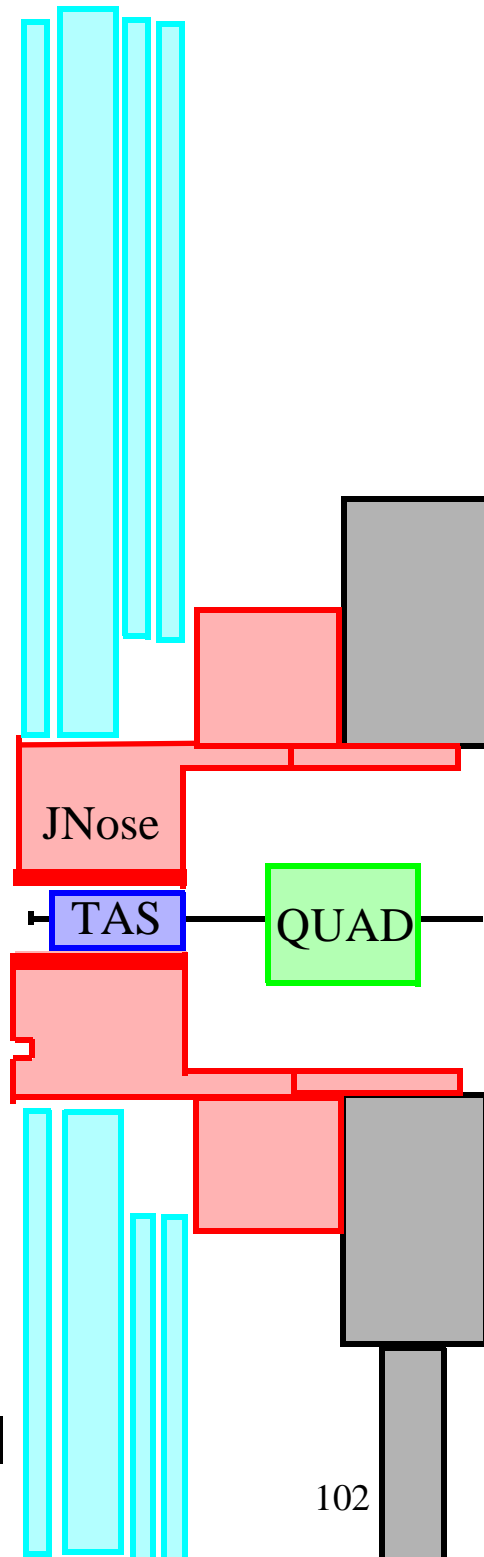
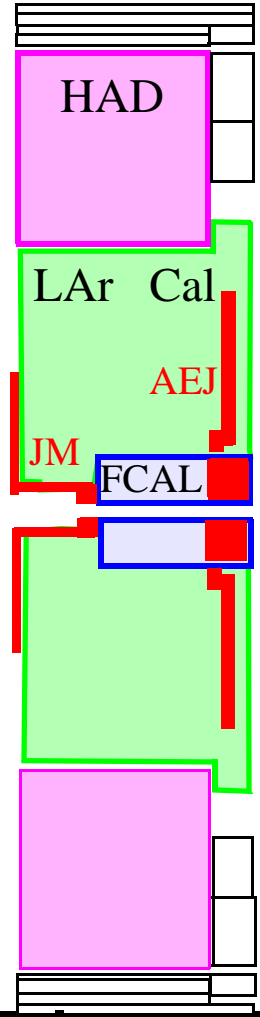
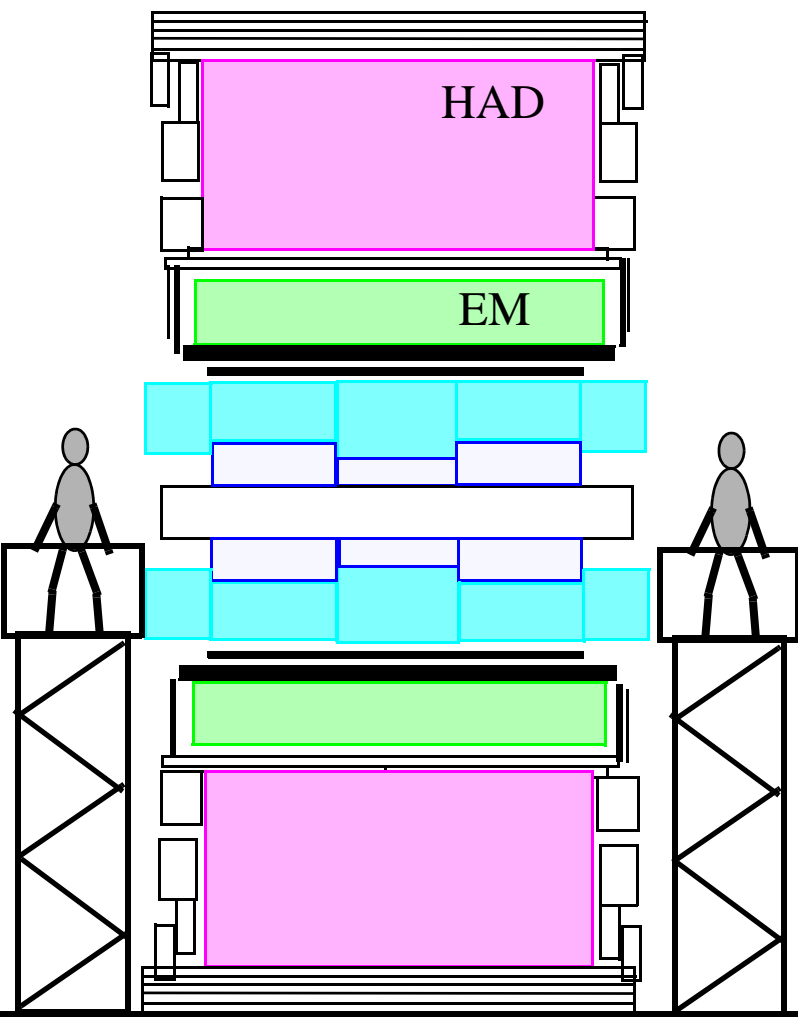

Rails

ACCESS

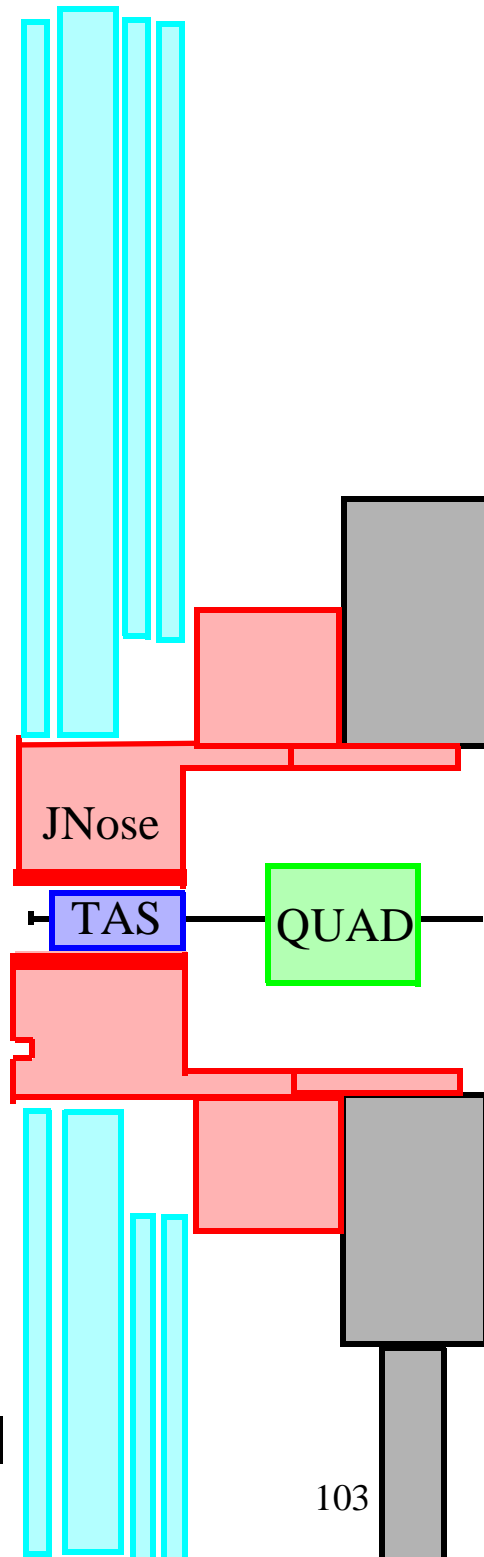
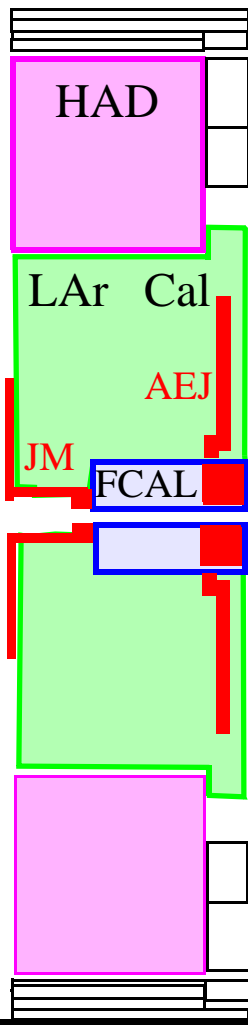
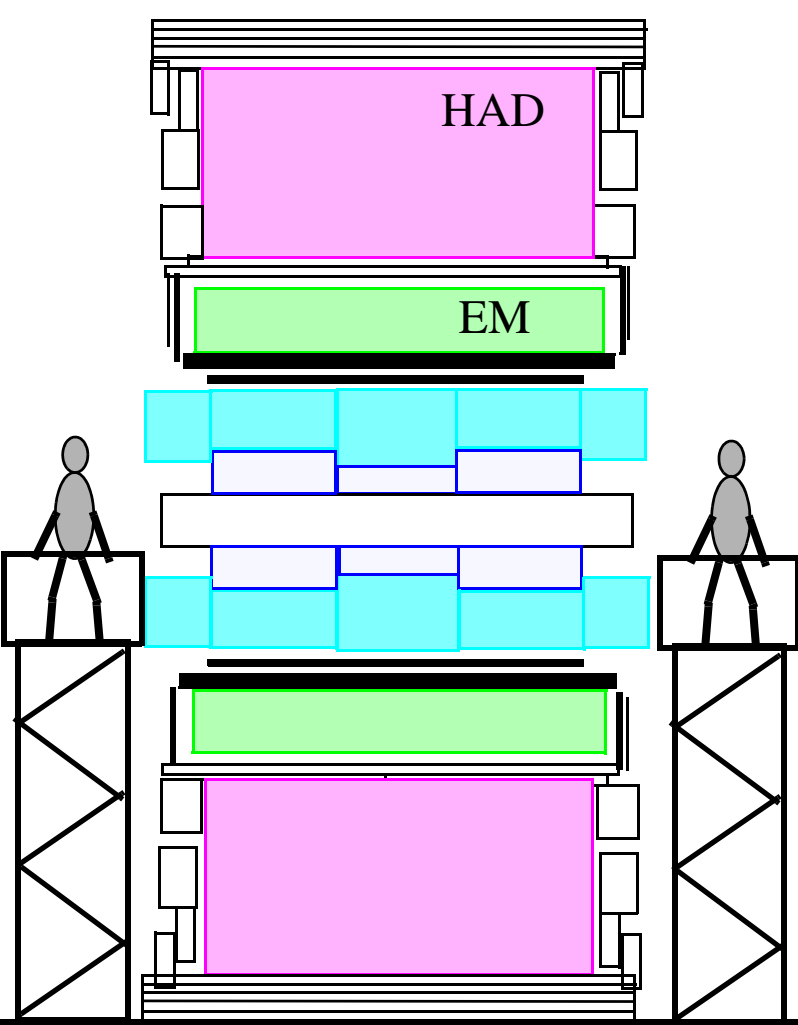

Rails

ACCESS

Is there access by the lift ?

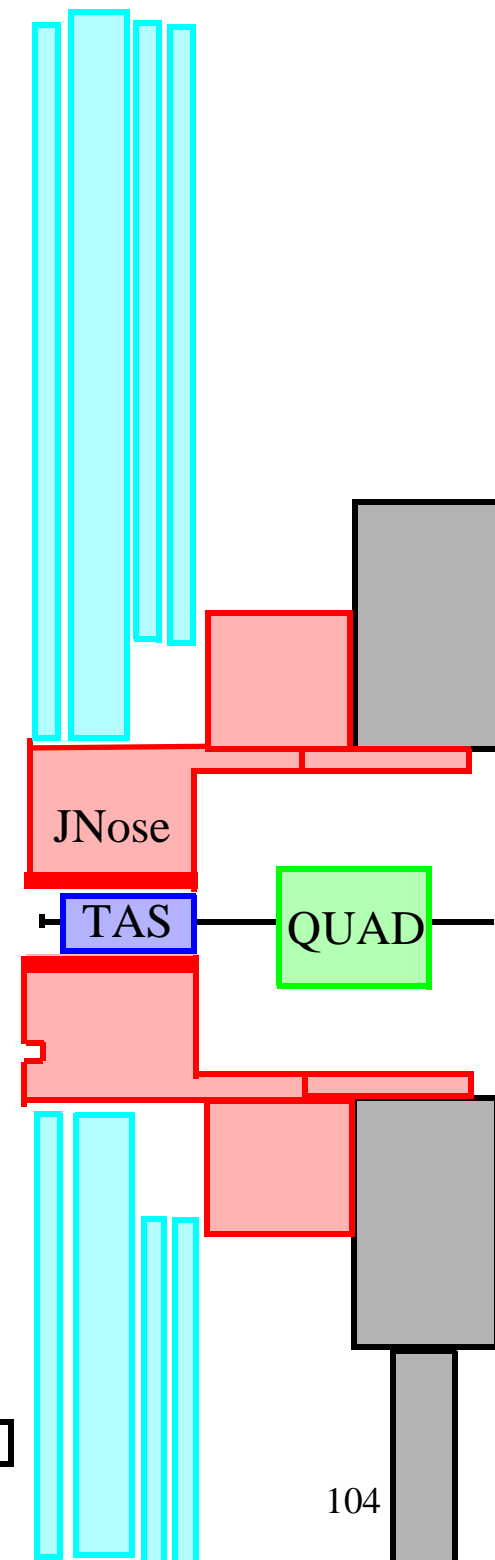
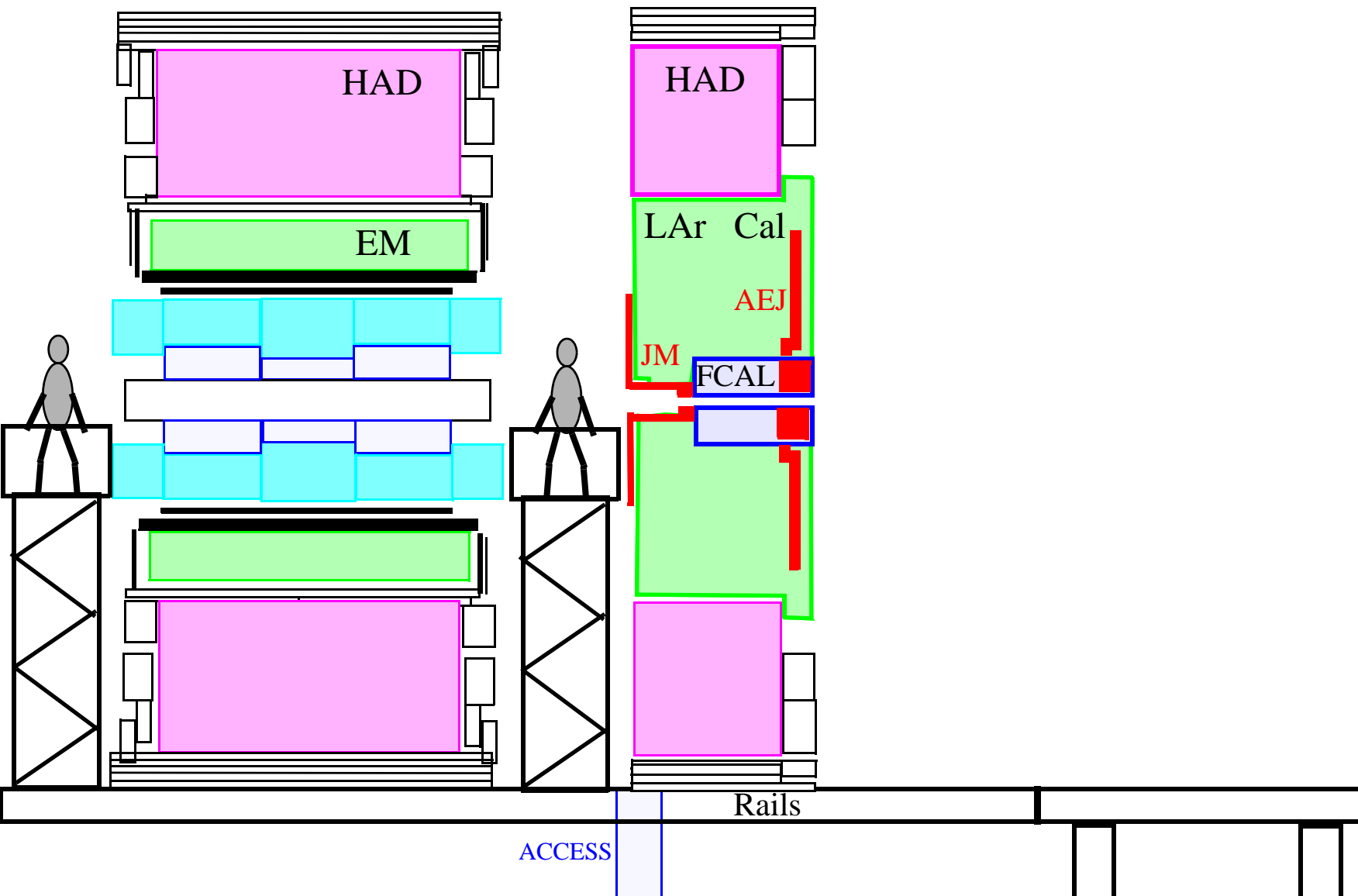

December 2006

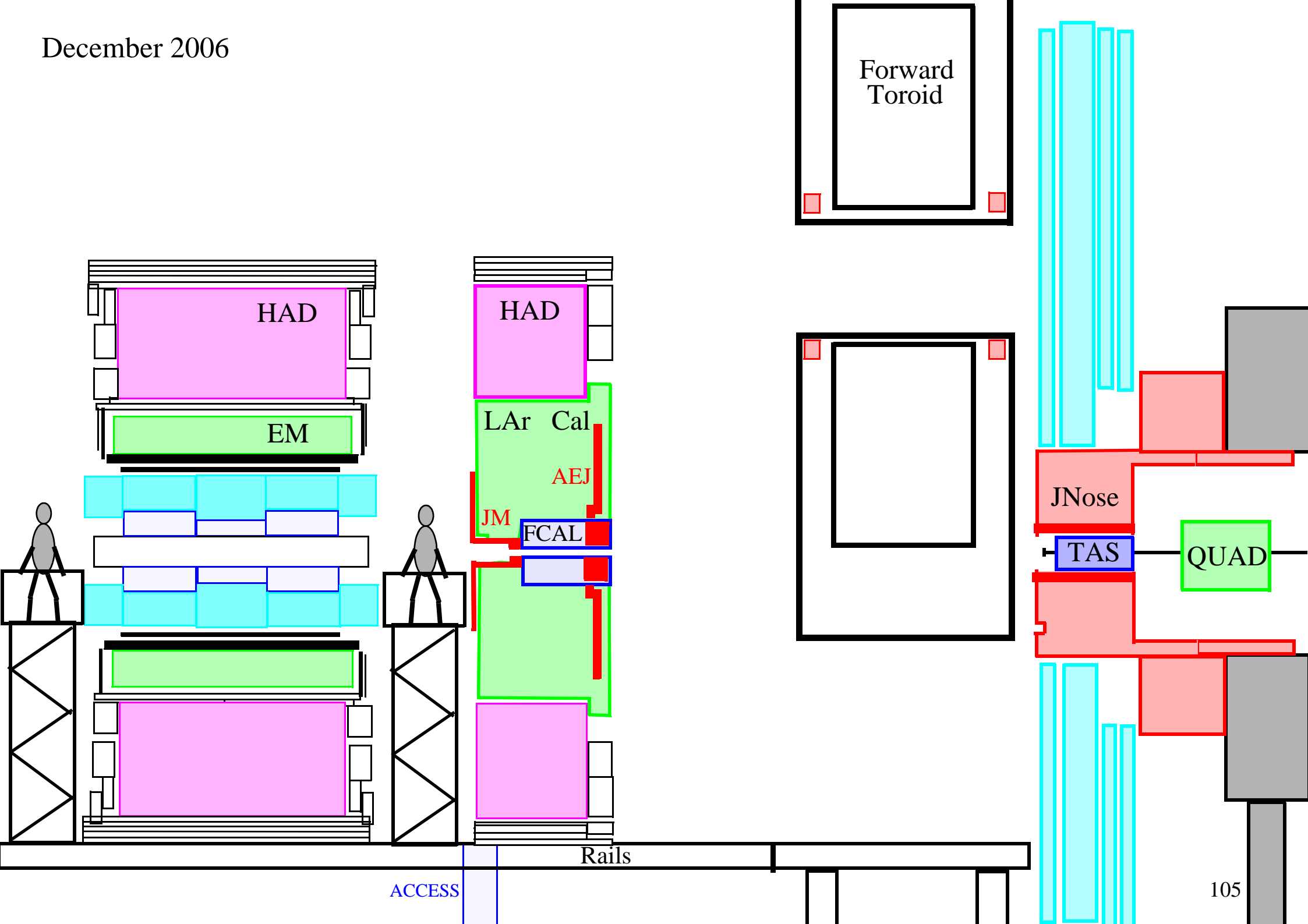

Forward
Toroid

HAD

EM

HAD

LAr Cal

AEJ

JM

FCAL

JNose

TAS

QUAD

Rails

ACCESS

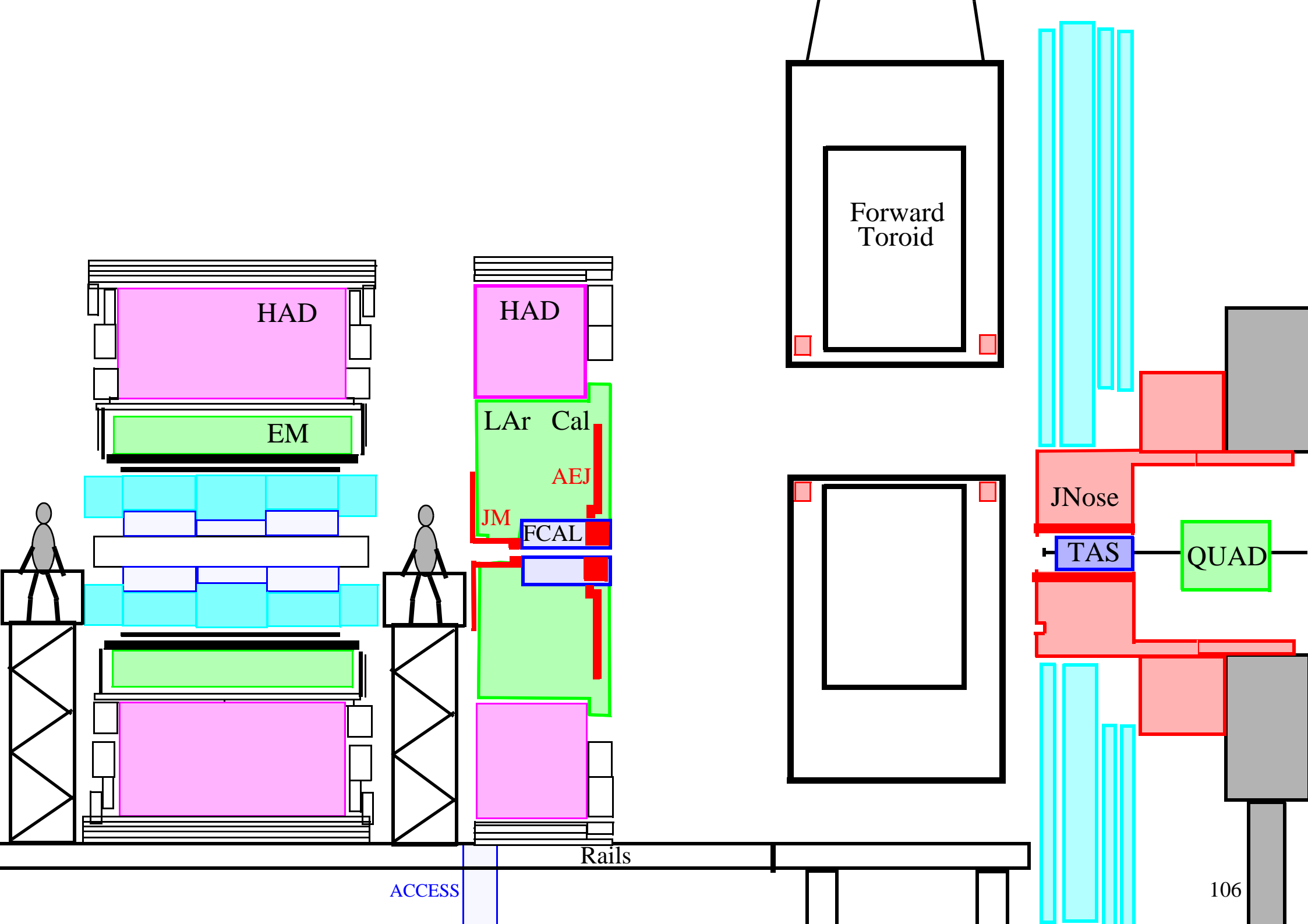

HAD

EM

HAD

LAr Cal

AEJ

JM

FCAL

Forward
Toroid

JNose

TAS

QUAD

Rails

ACCESS

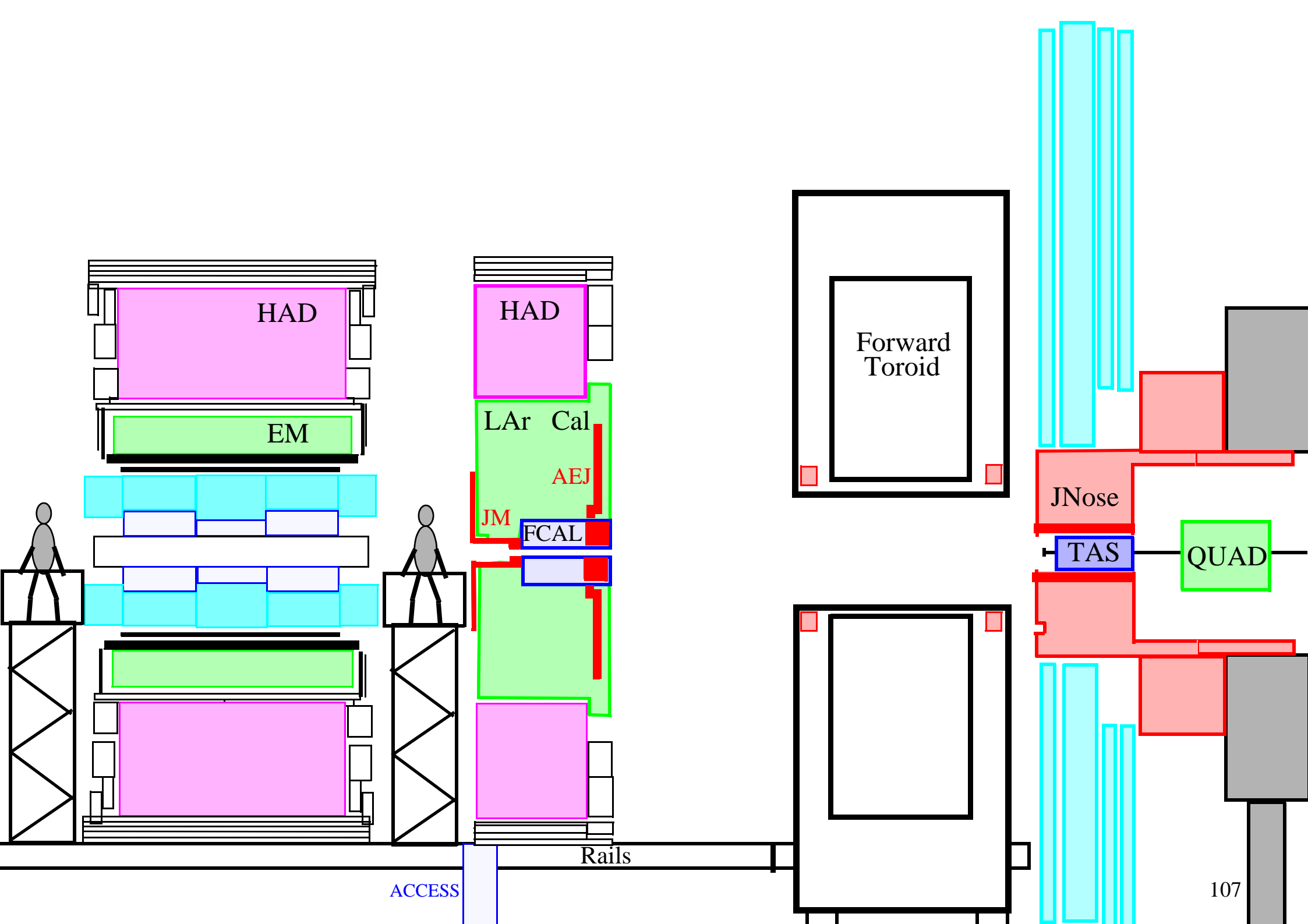

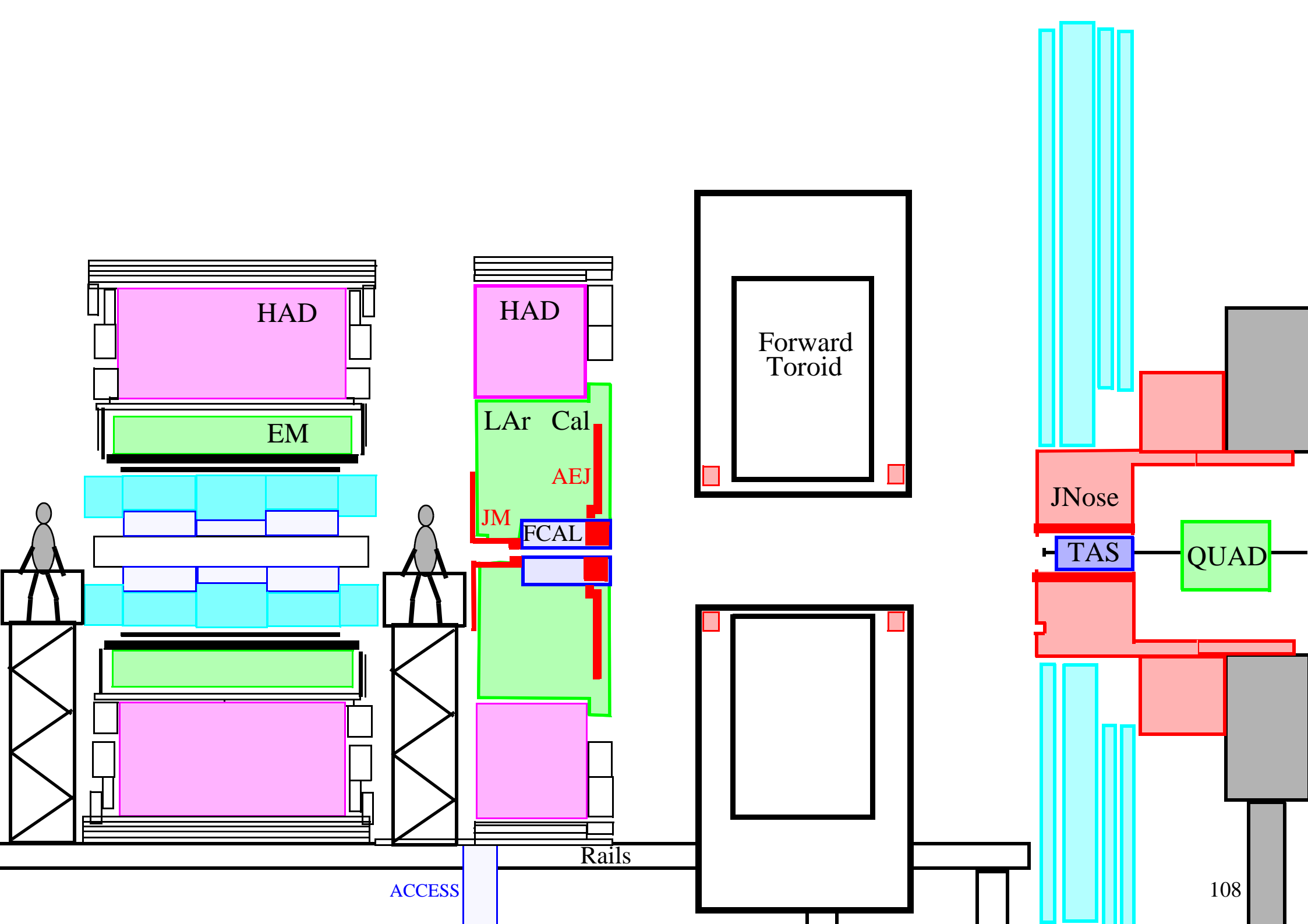

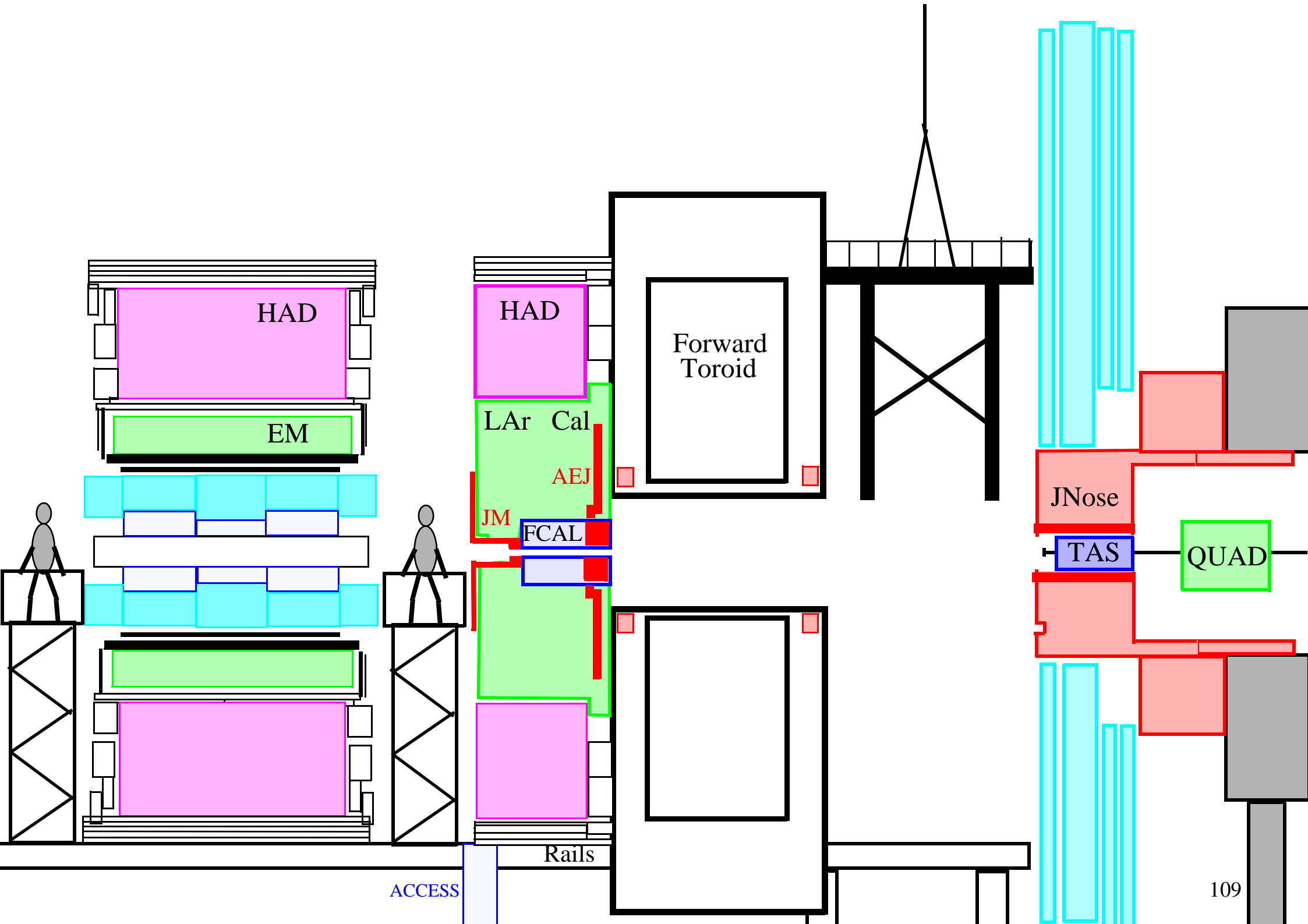

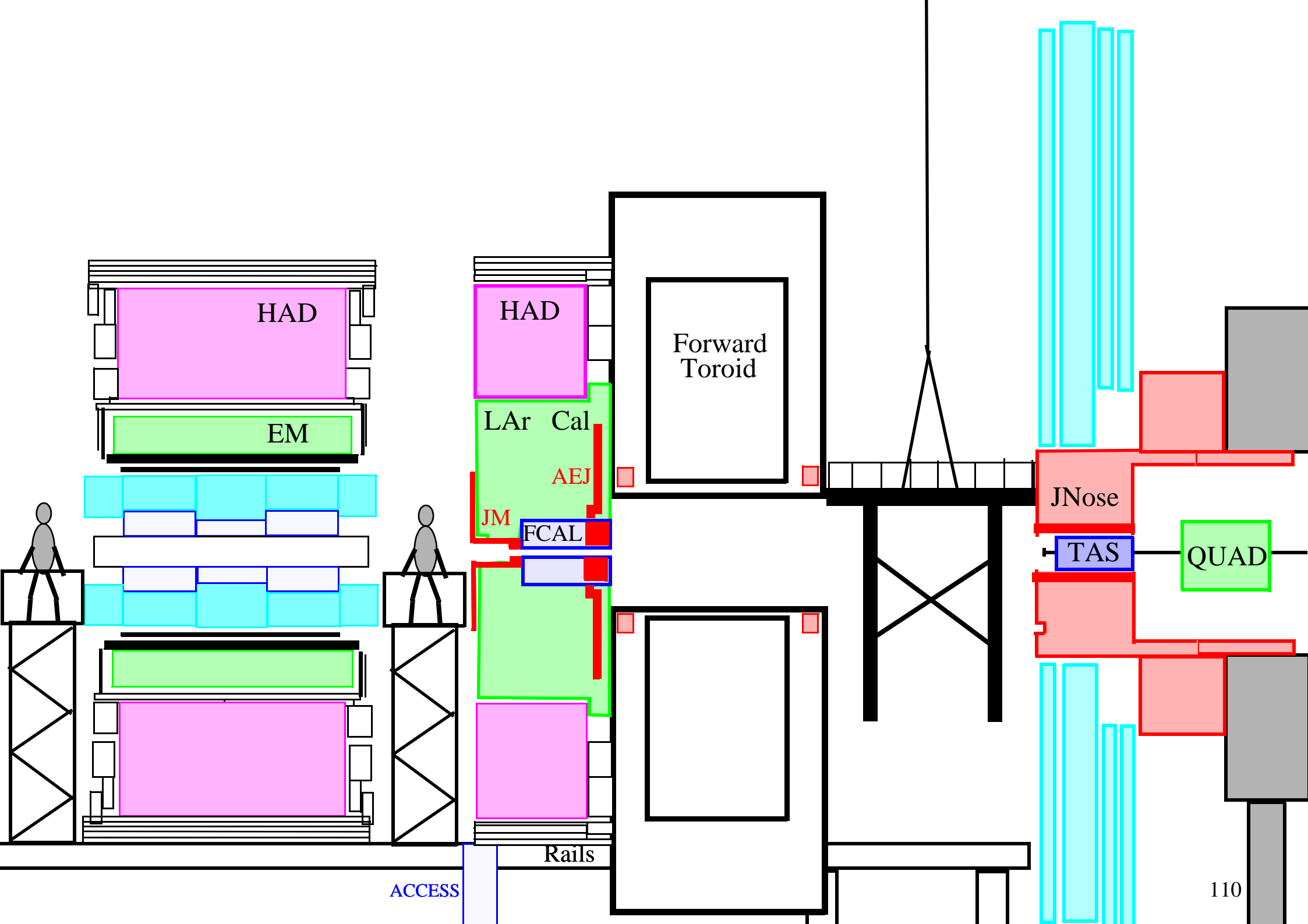

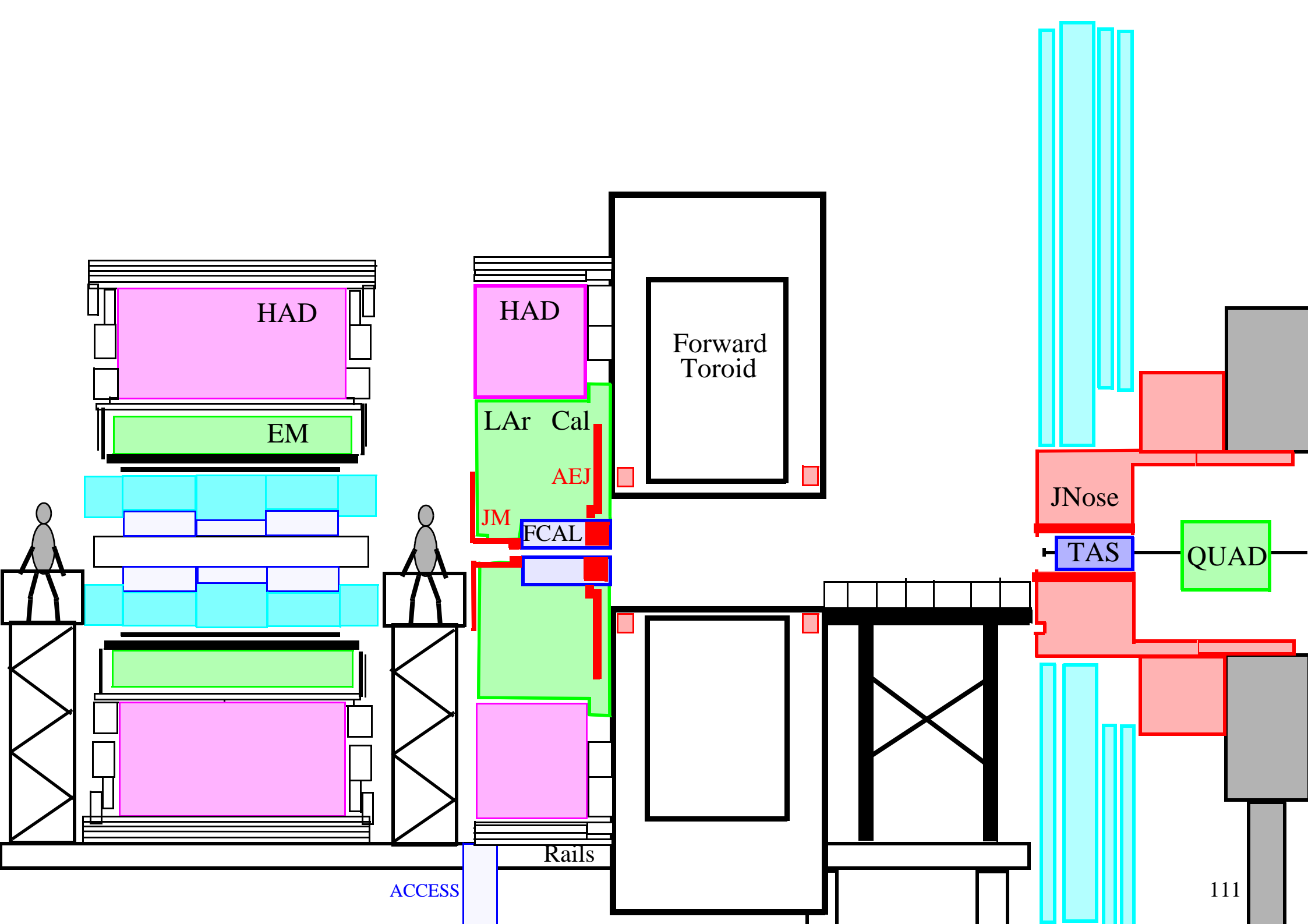



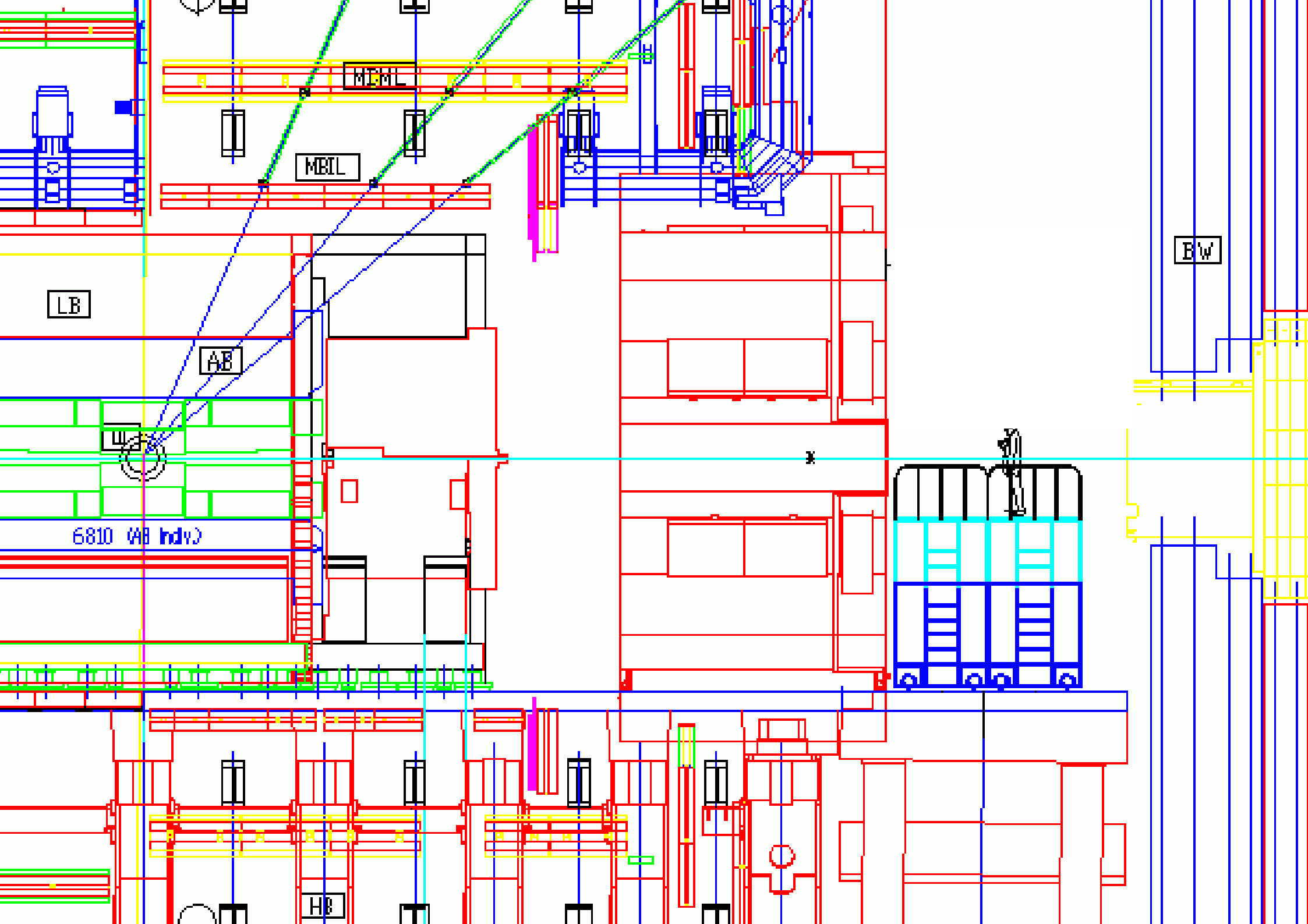

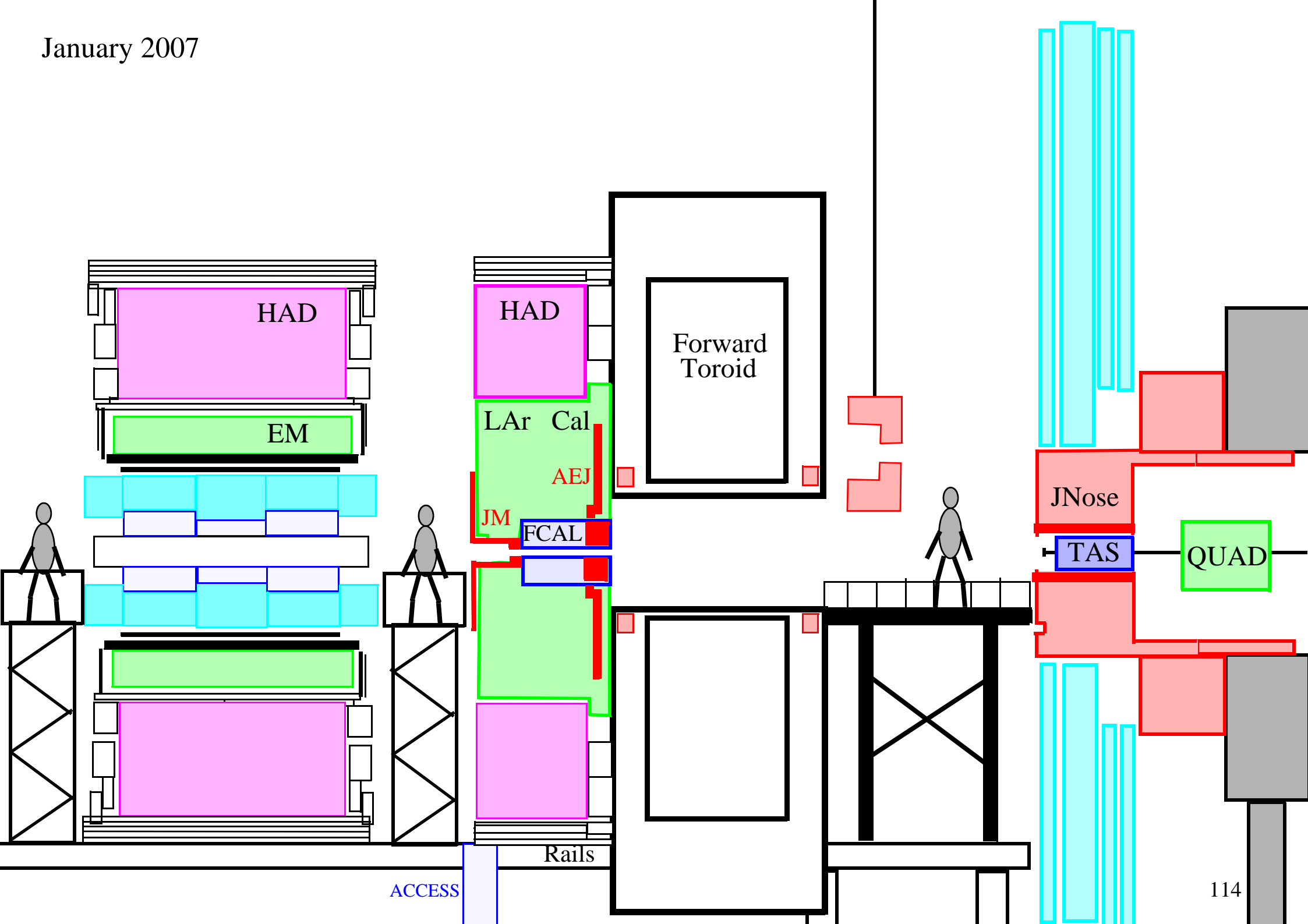

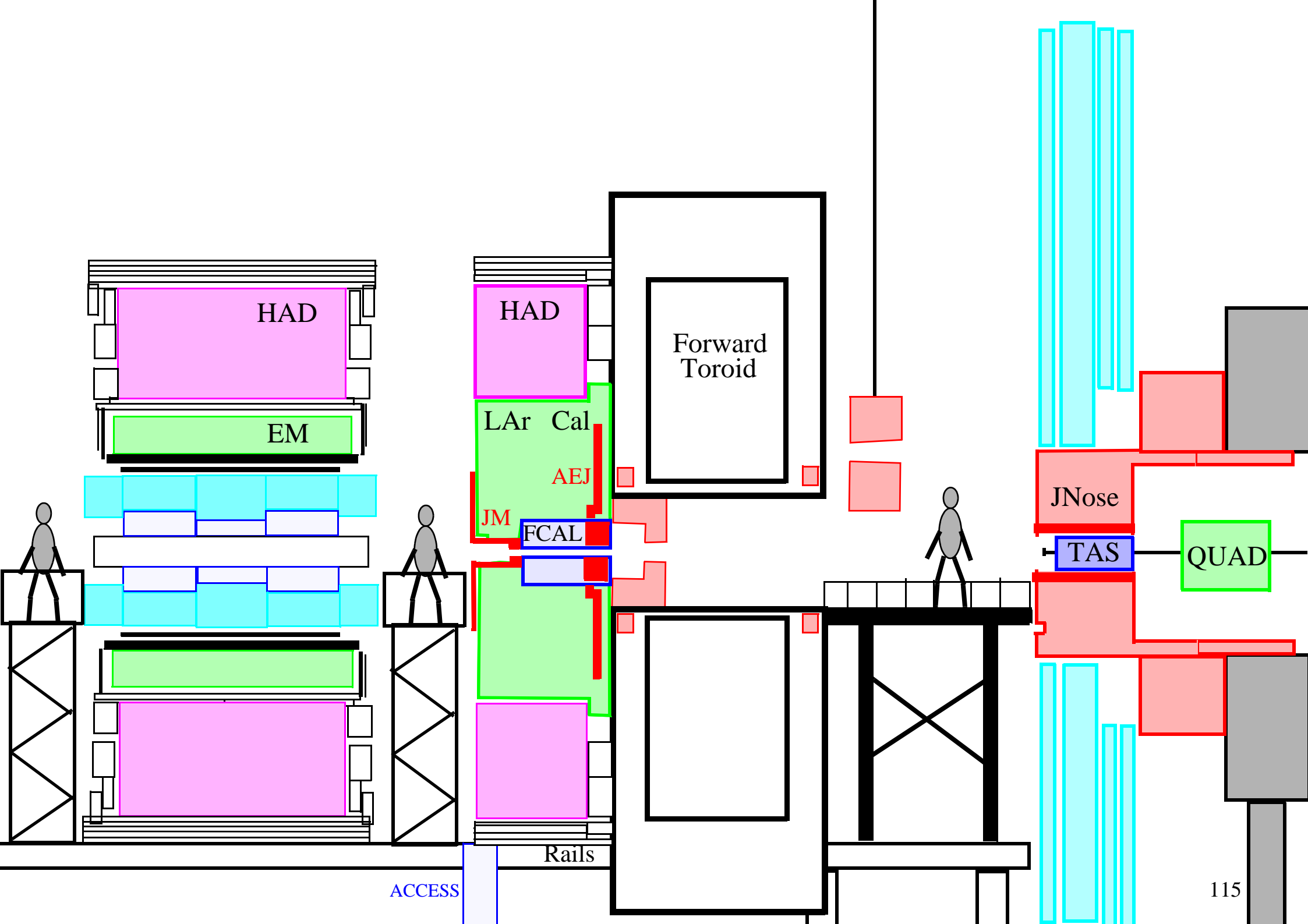

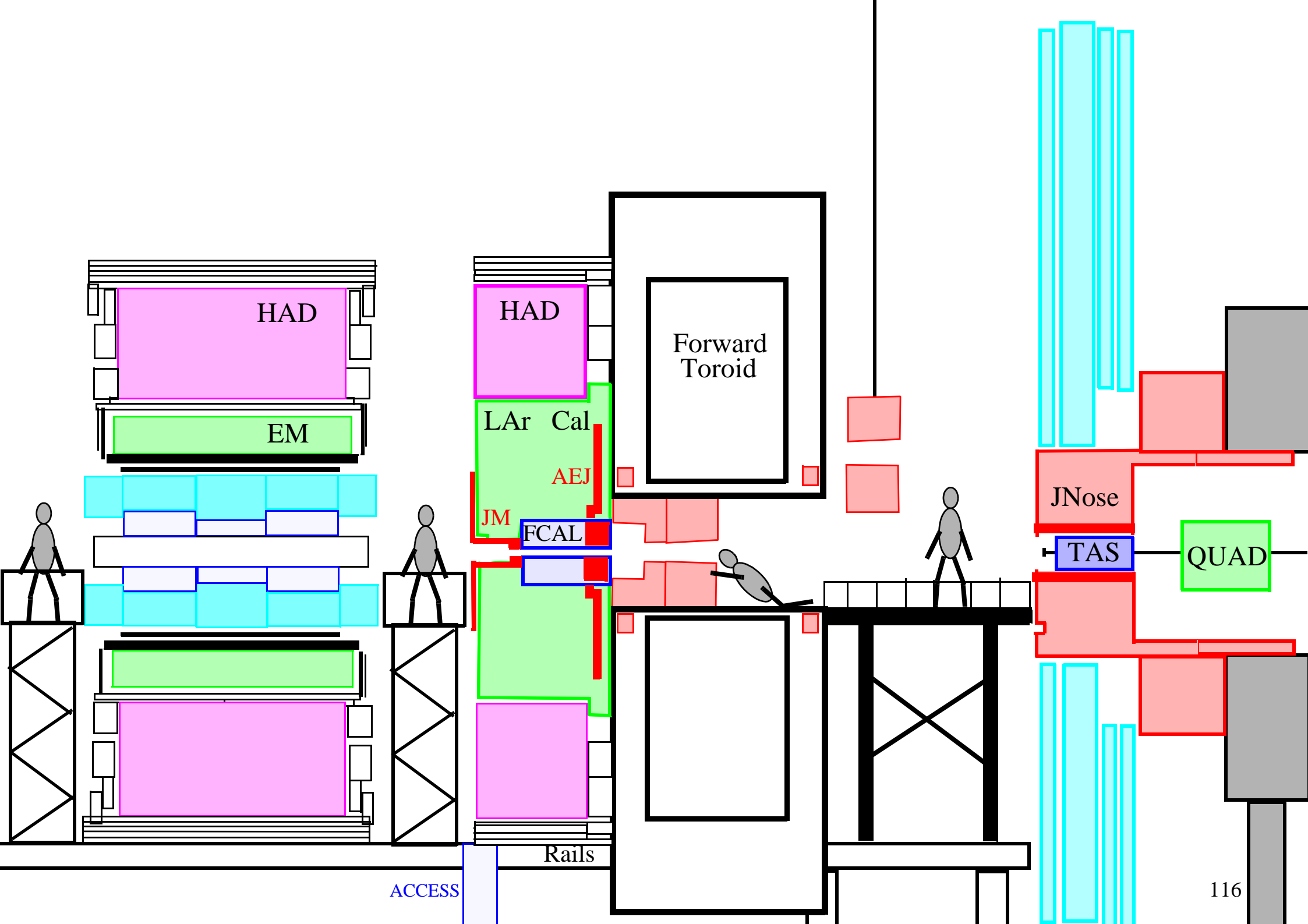

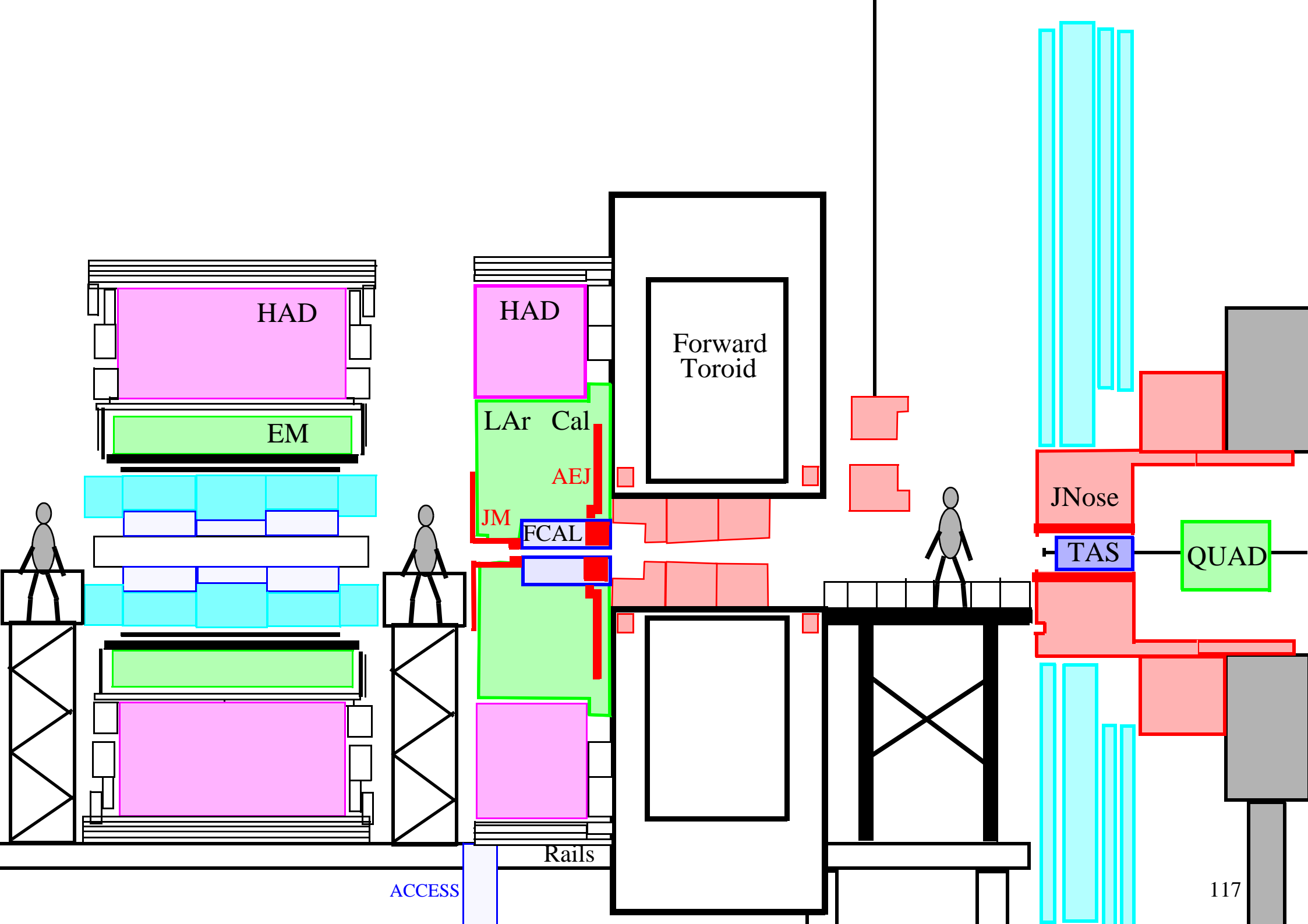

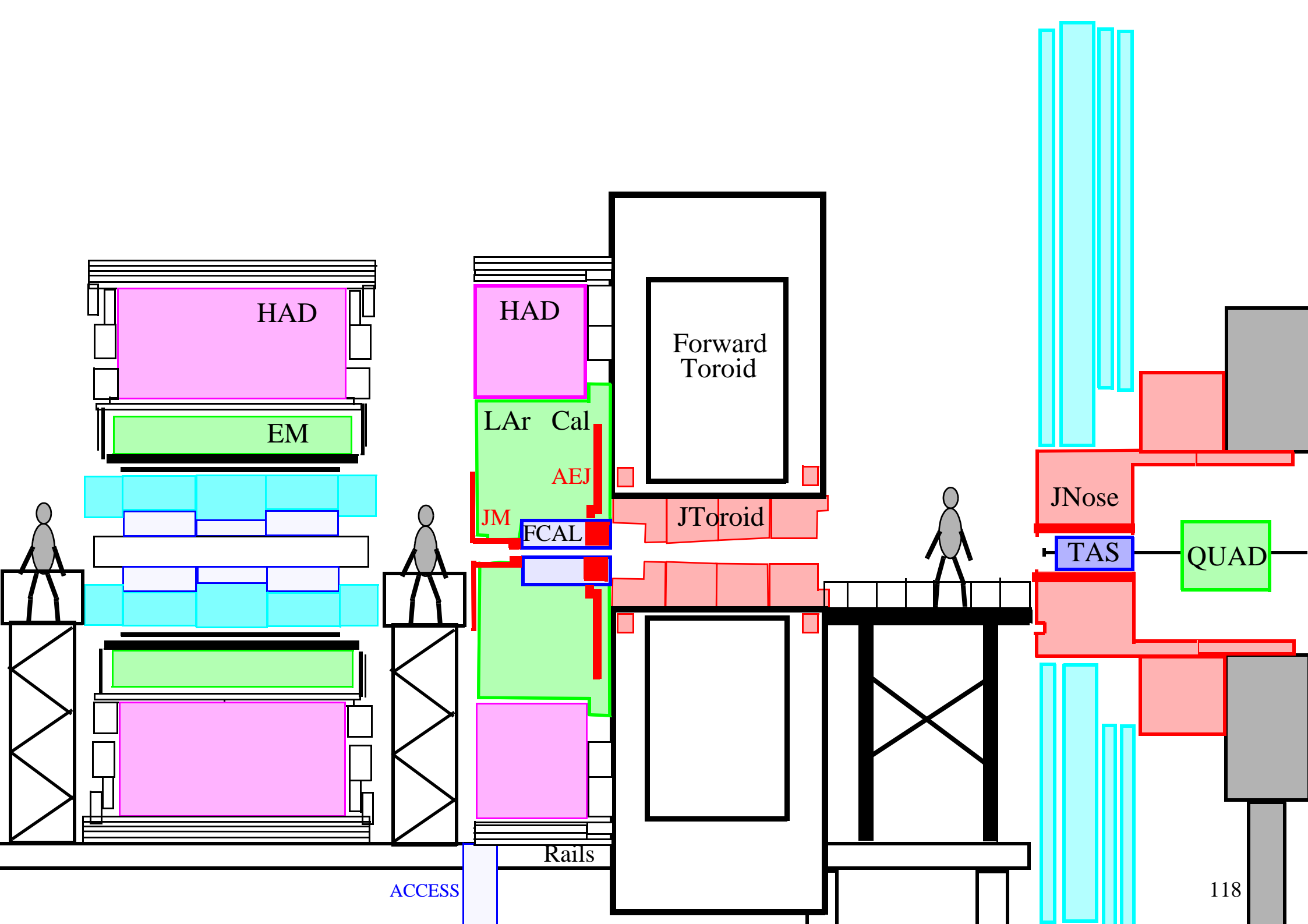

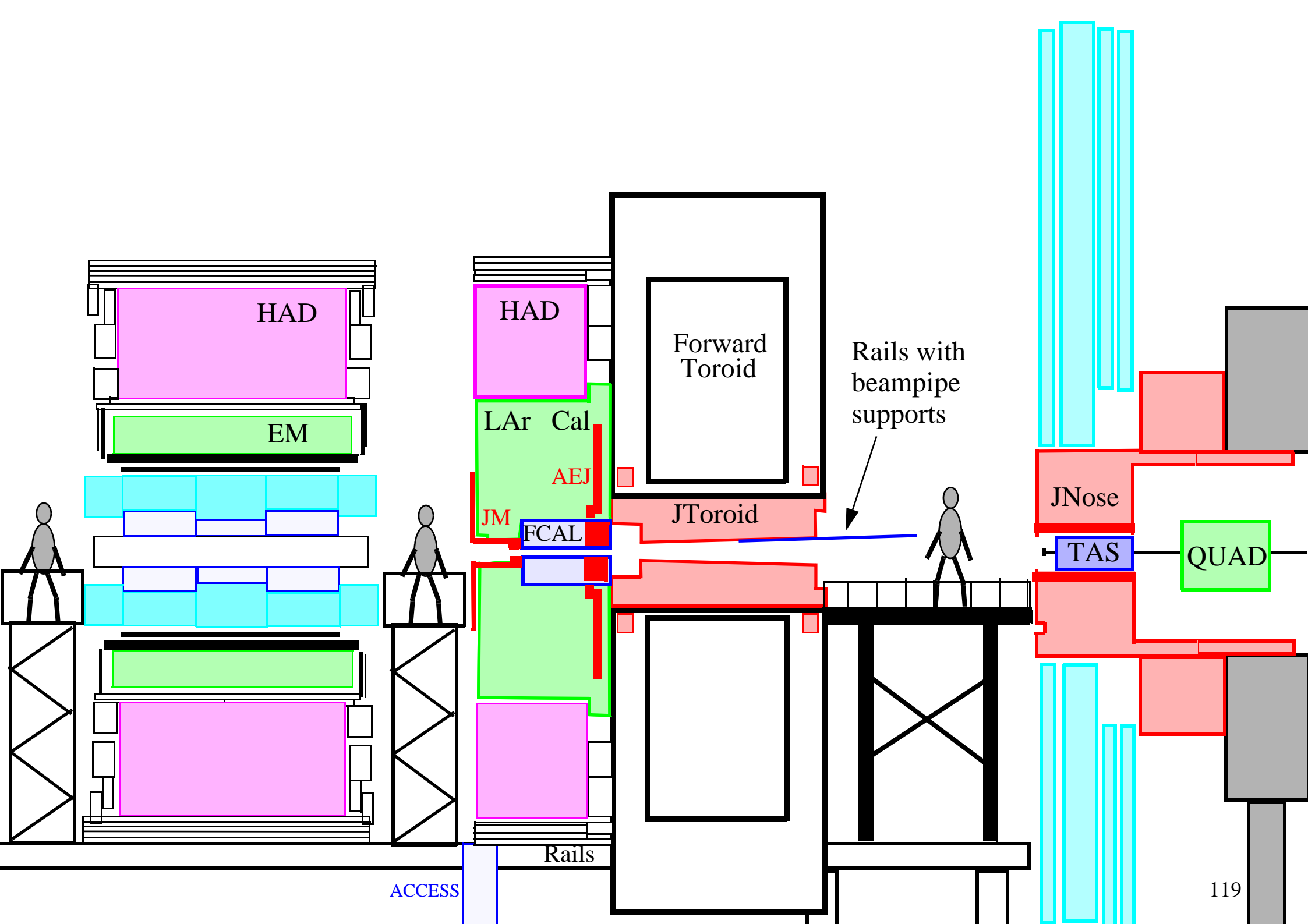

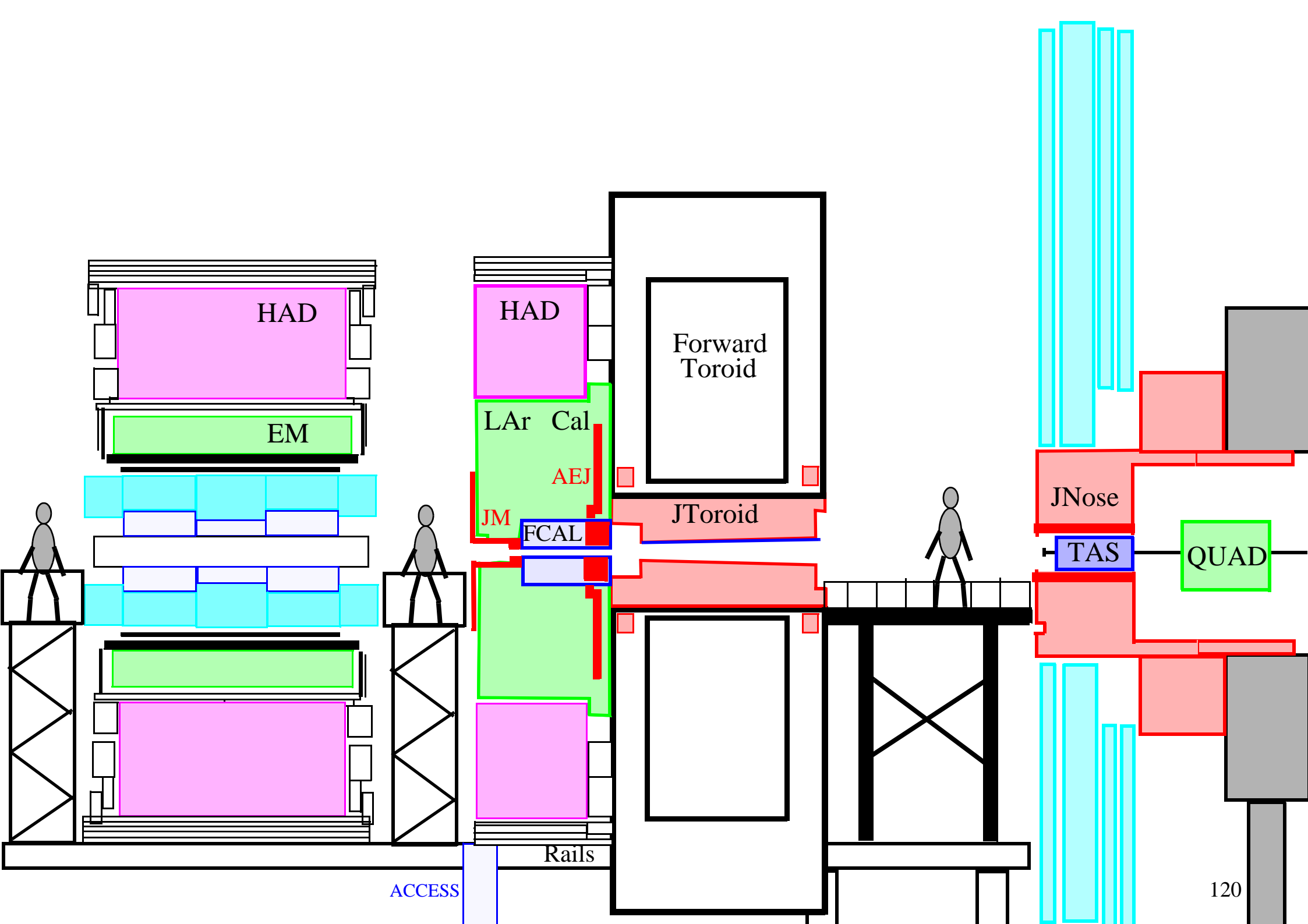

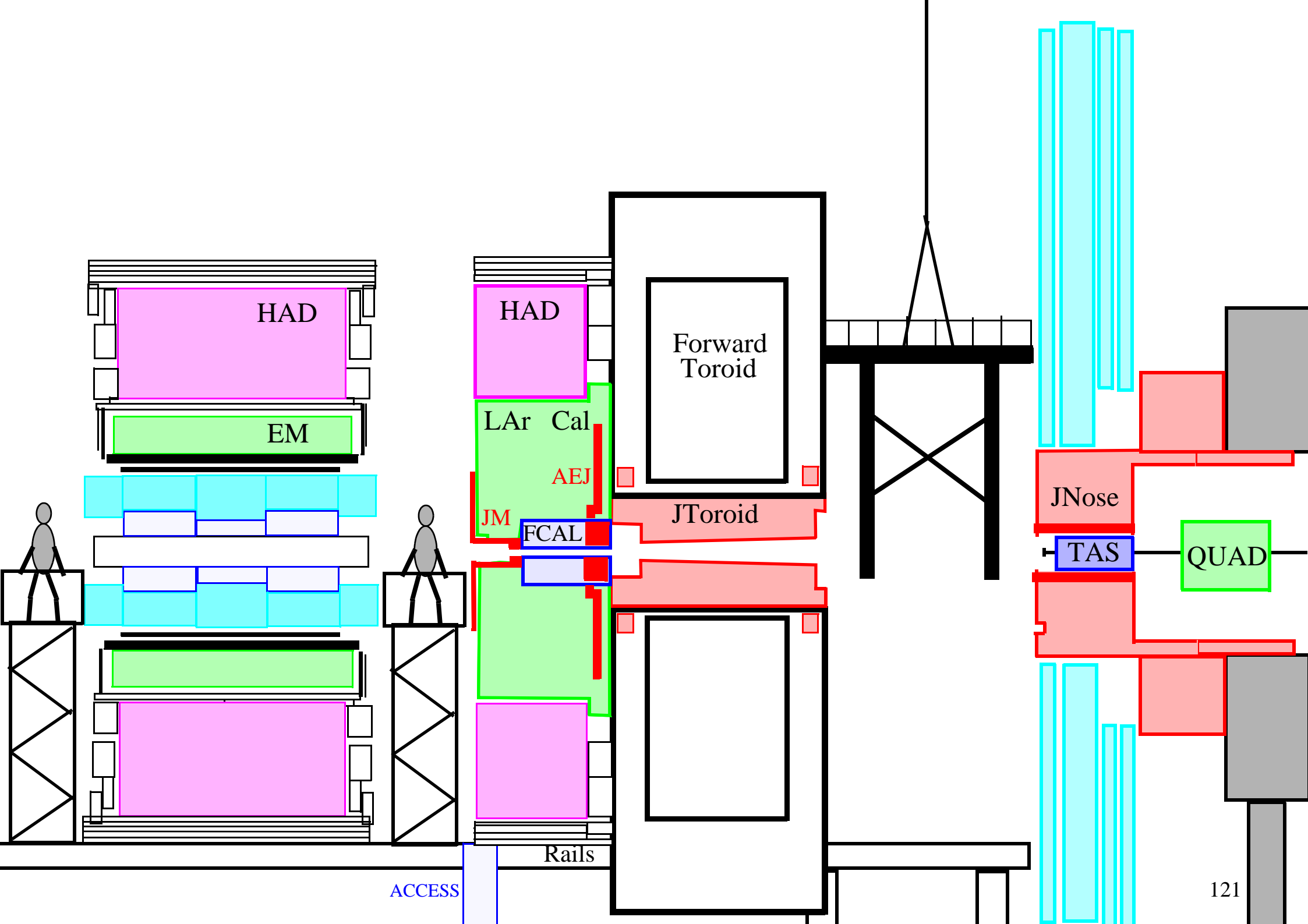

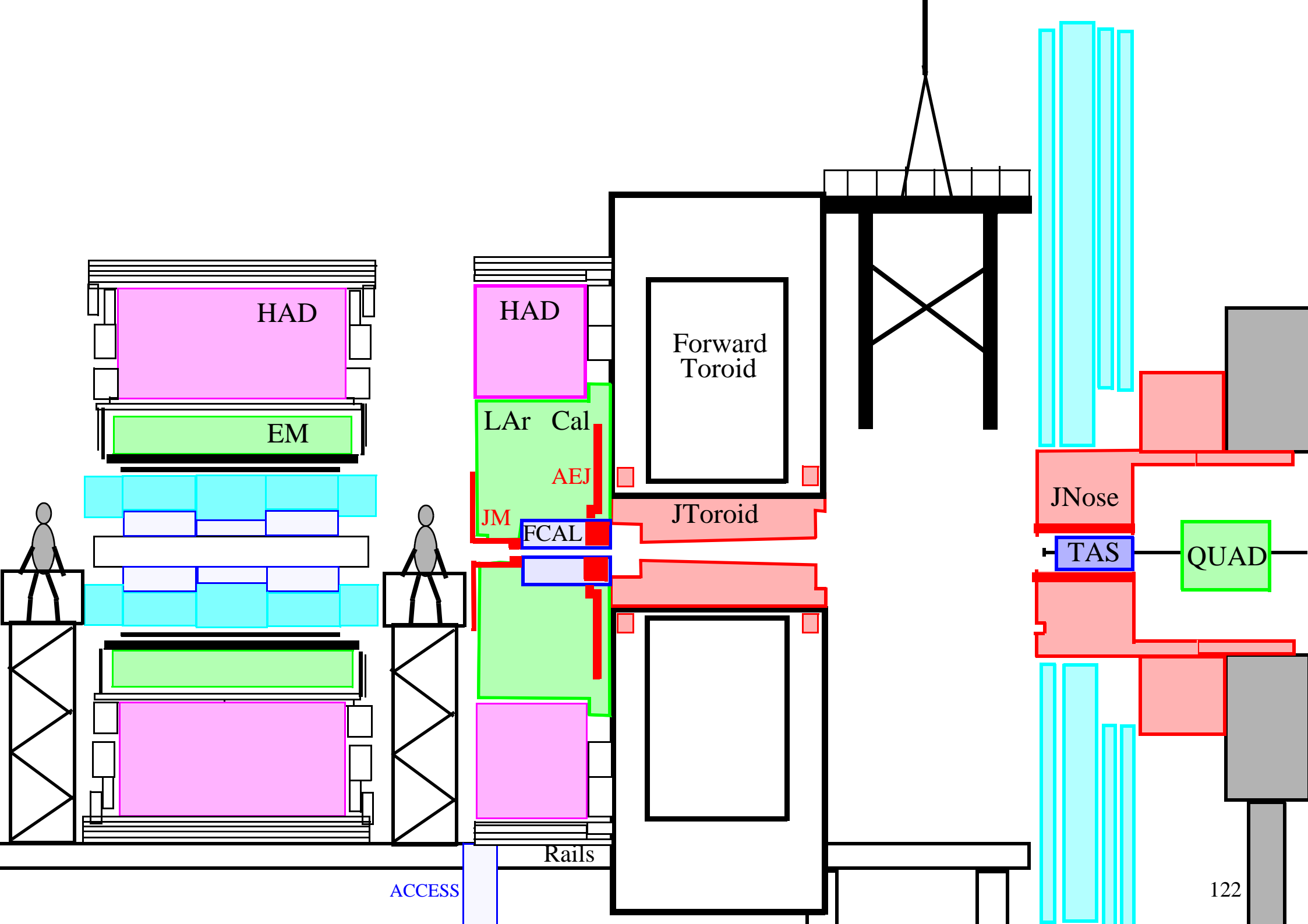

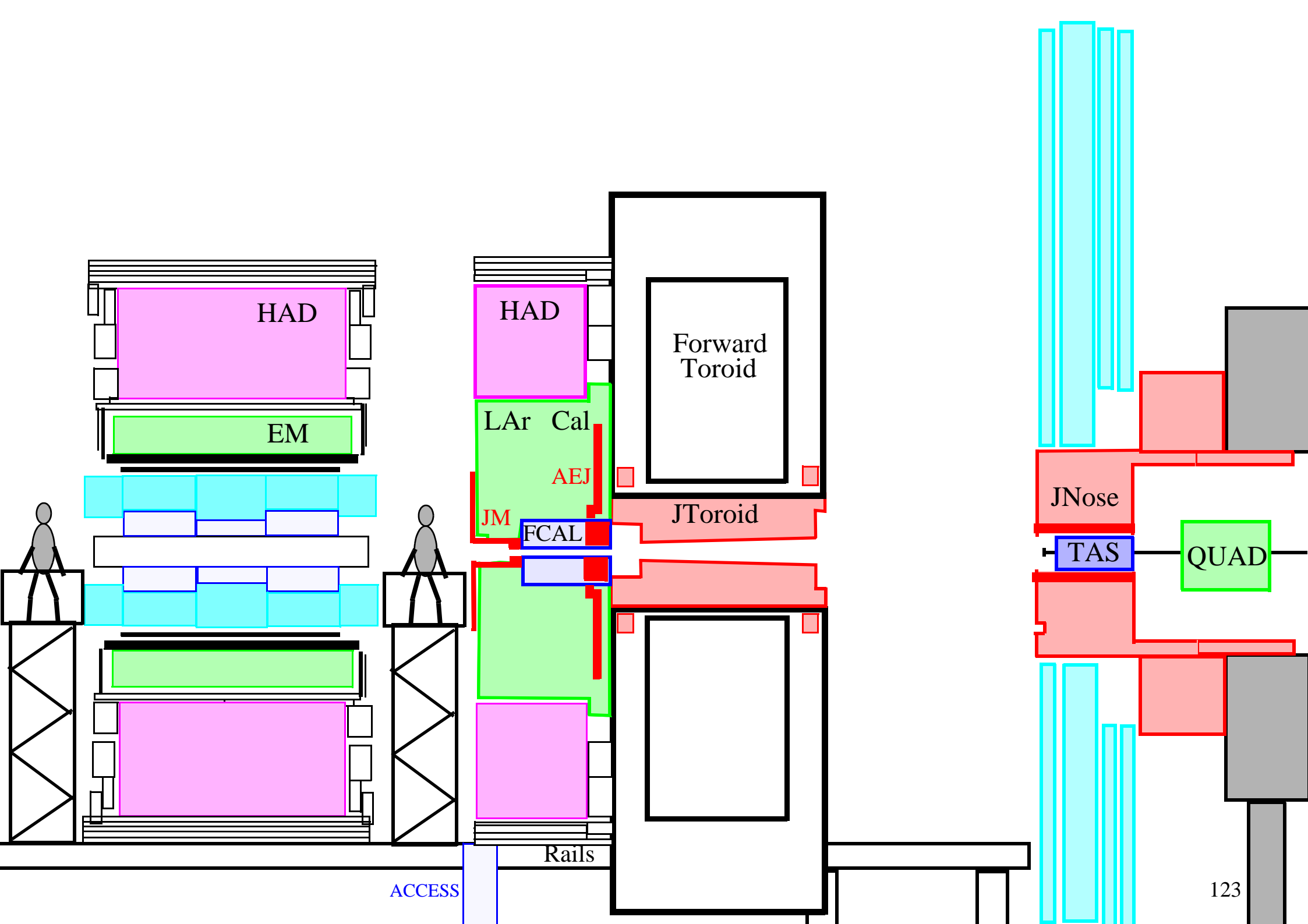

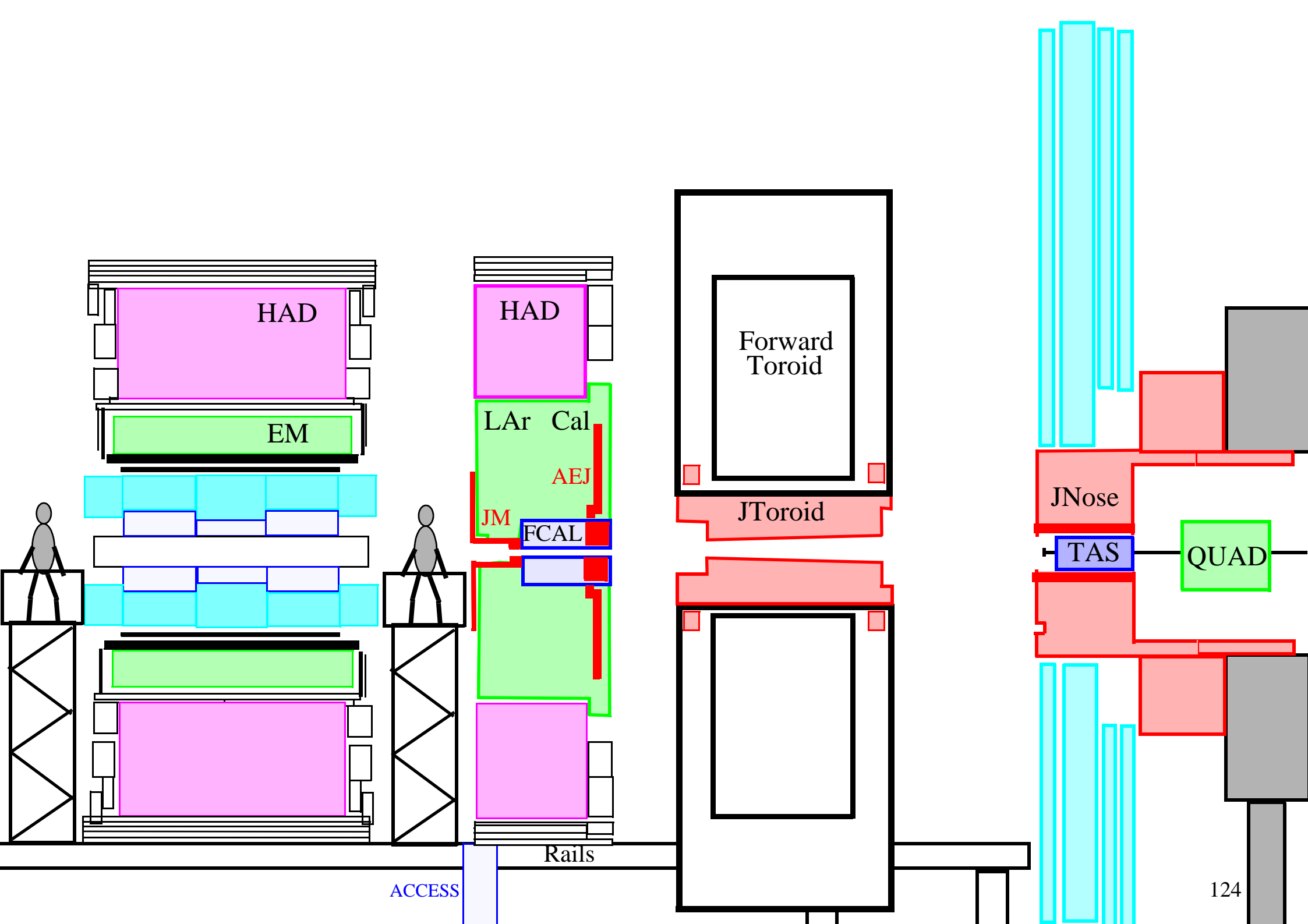

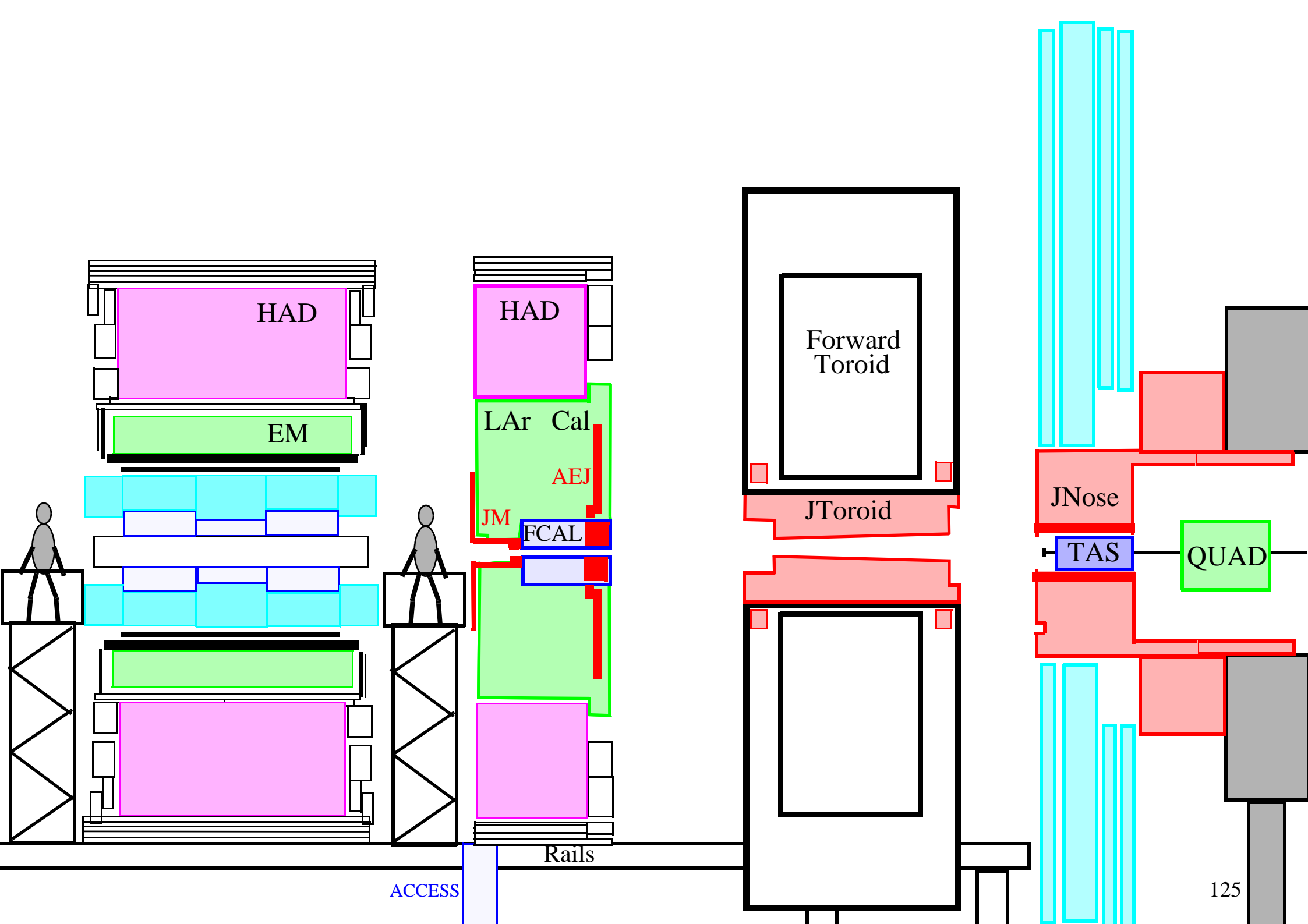

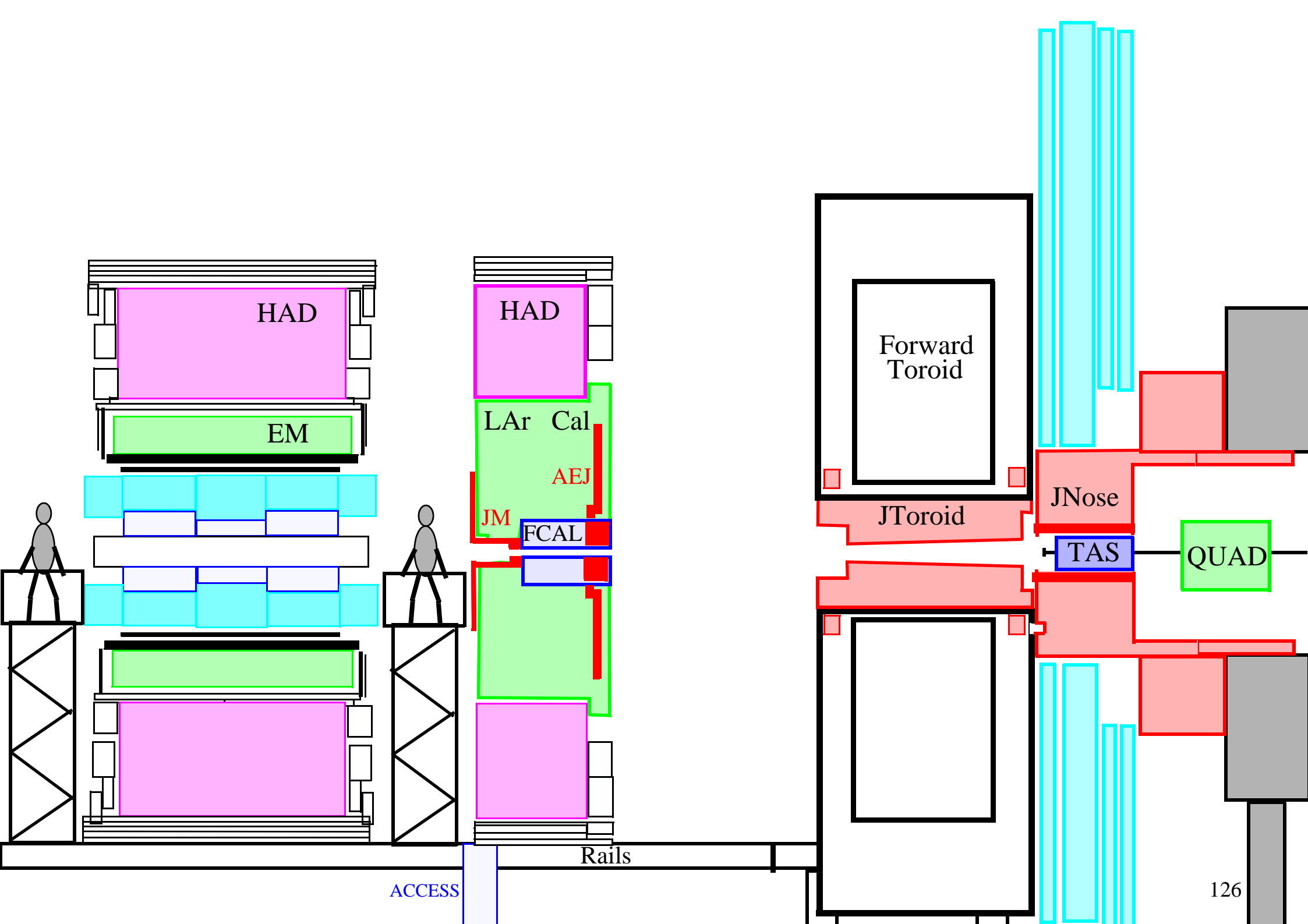

February 2007

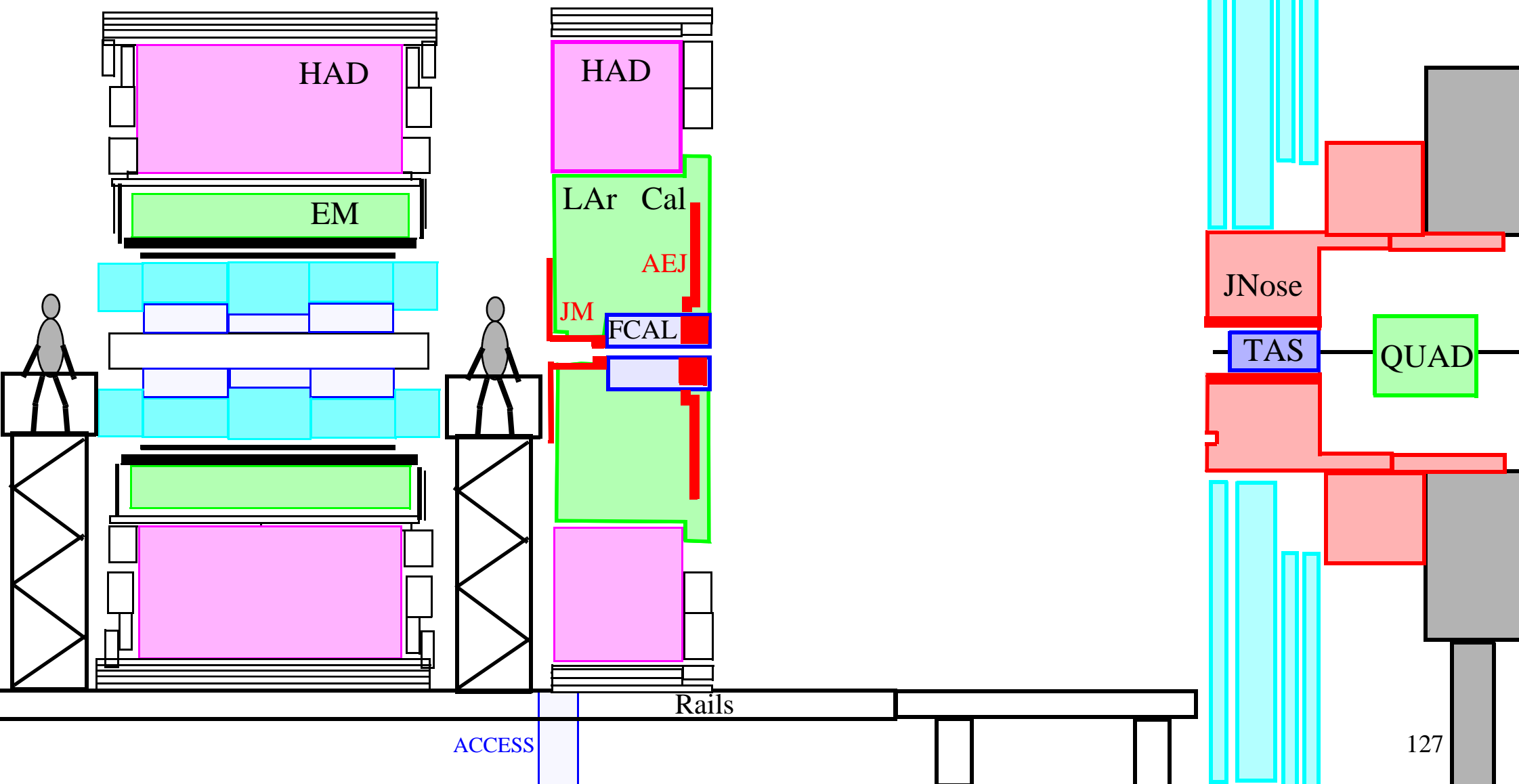

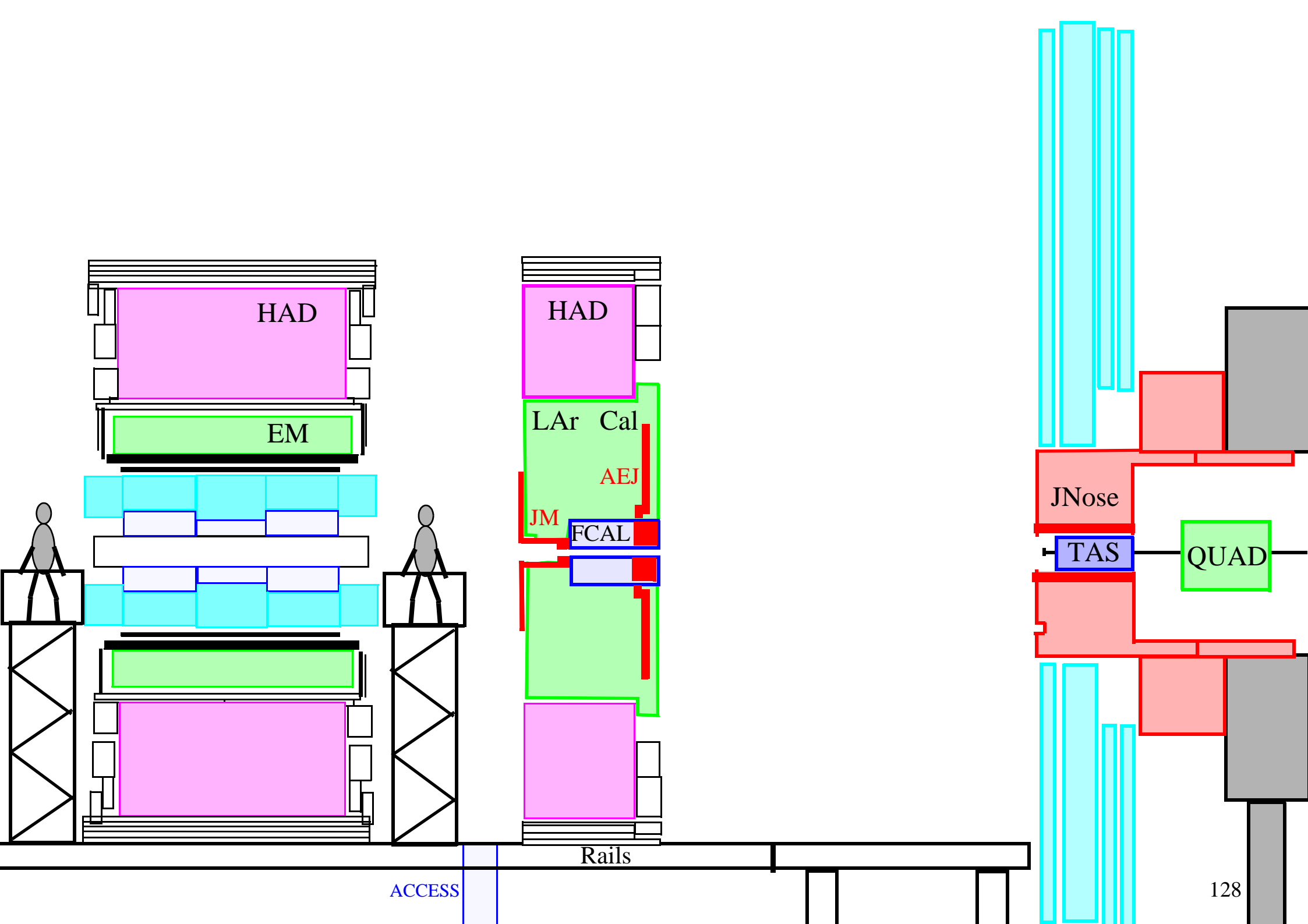

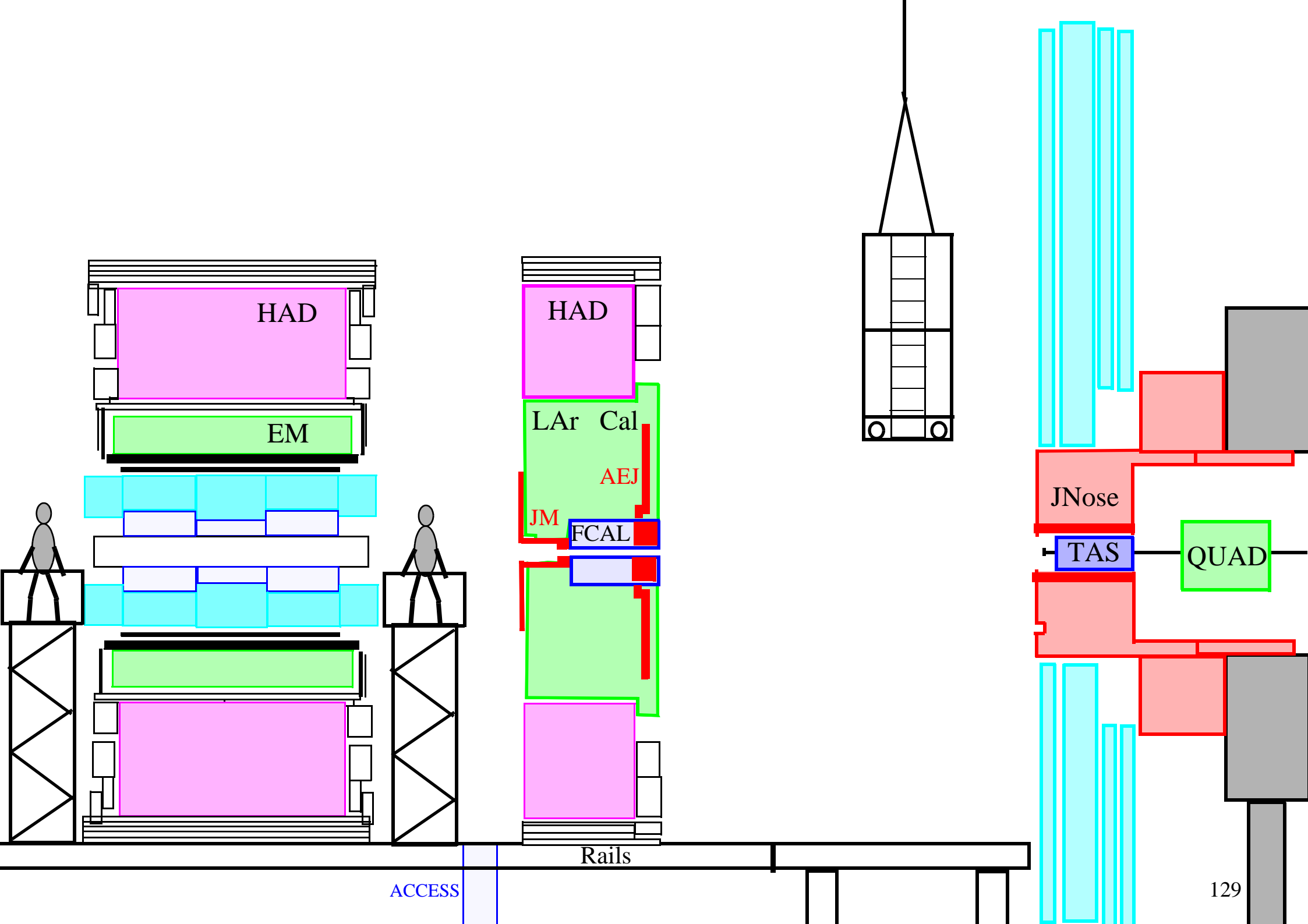

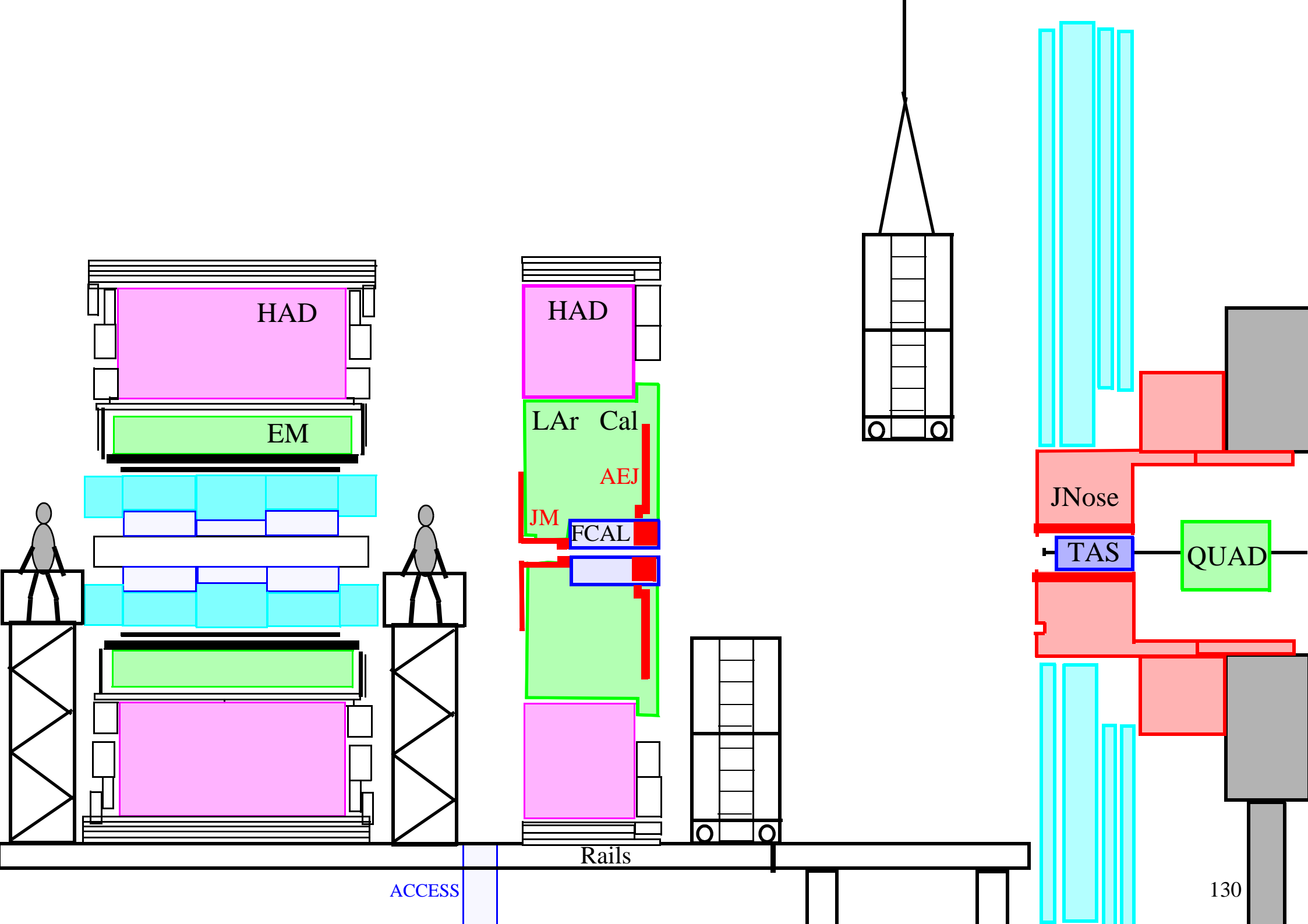

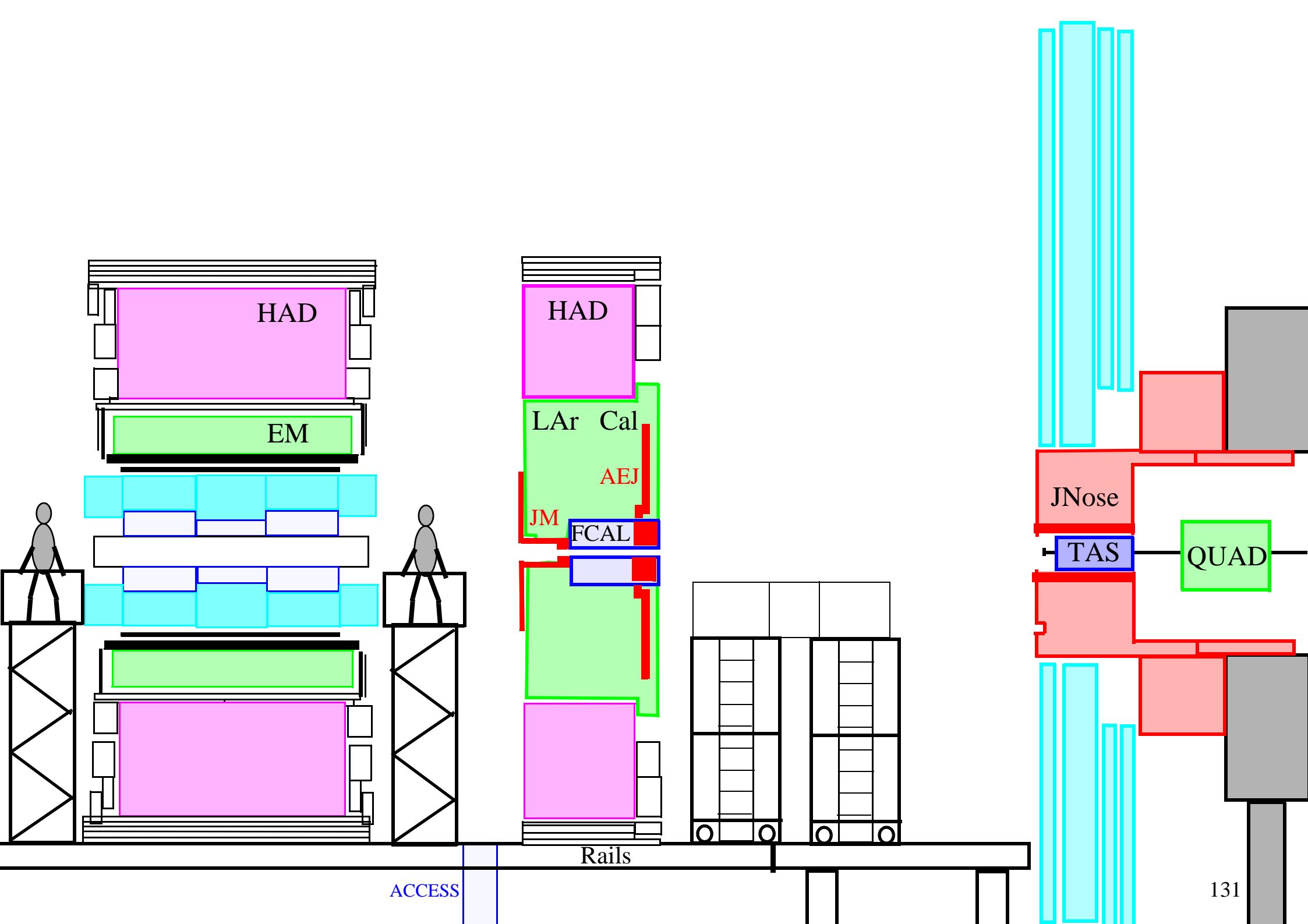

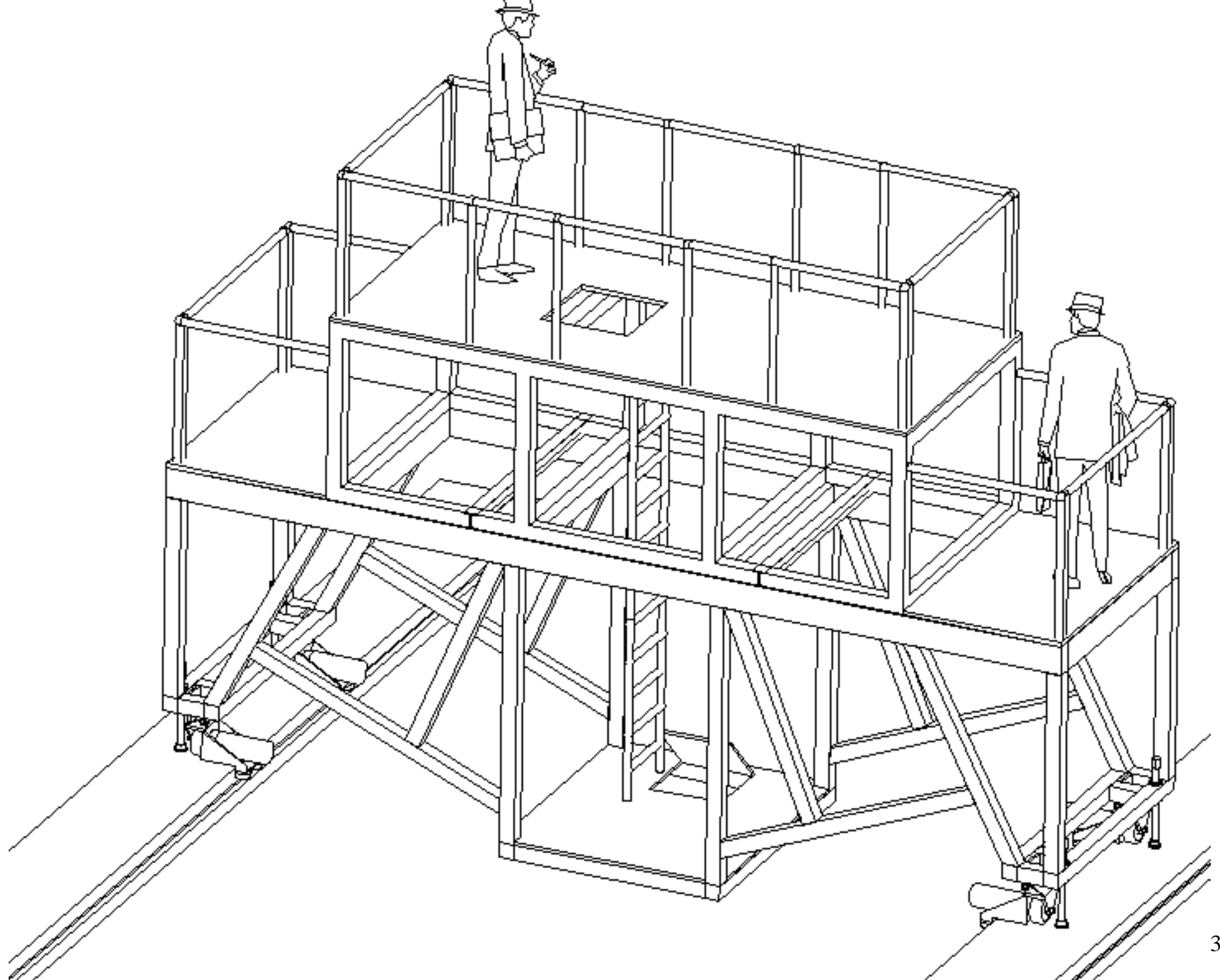

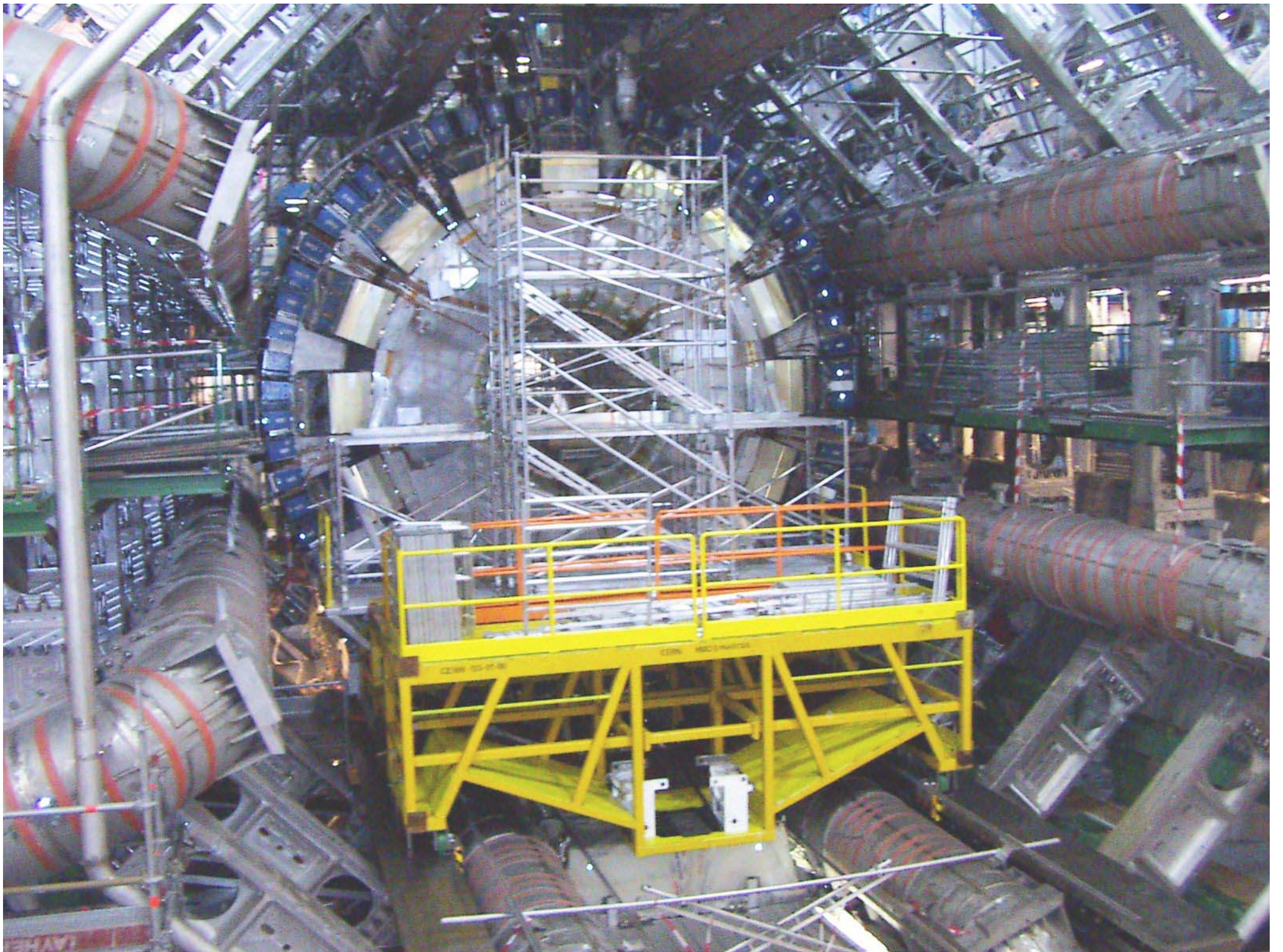

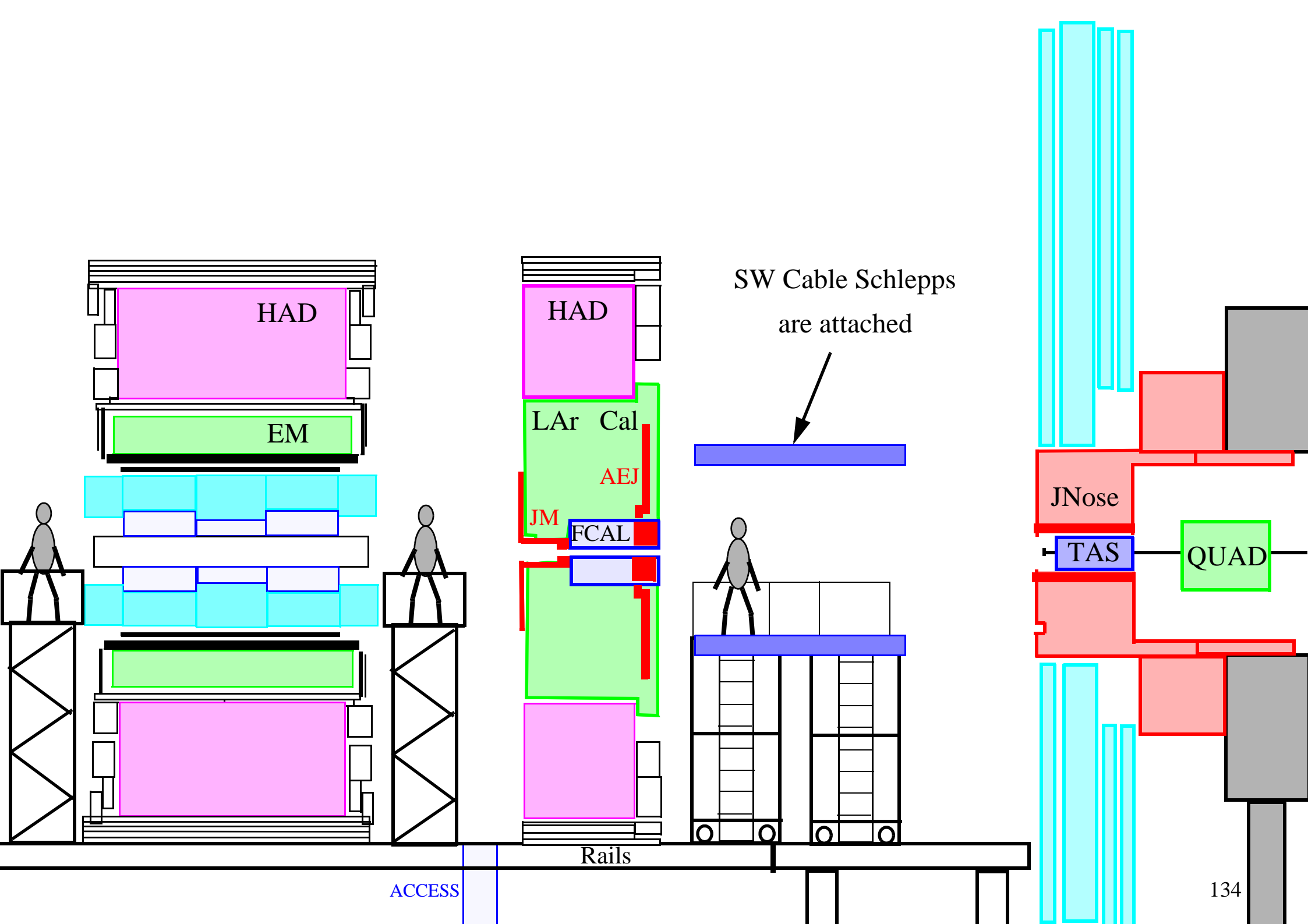

HAD

EM

HAD

LAr Cal

FCAL

FCAL

Rails

ACCESS

SW Cable Schlepps
are attached

JNose

TAS

QUAD

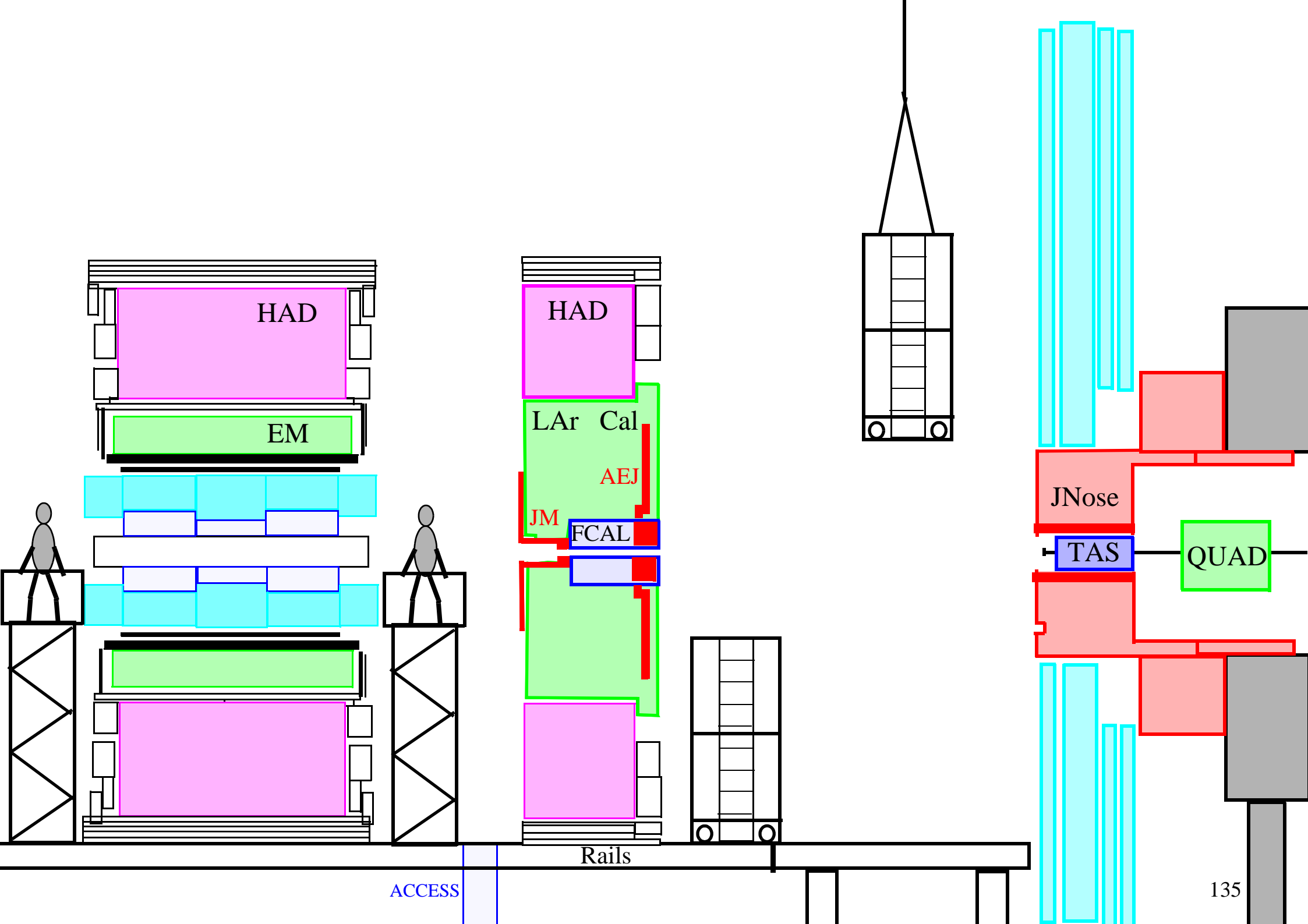

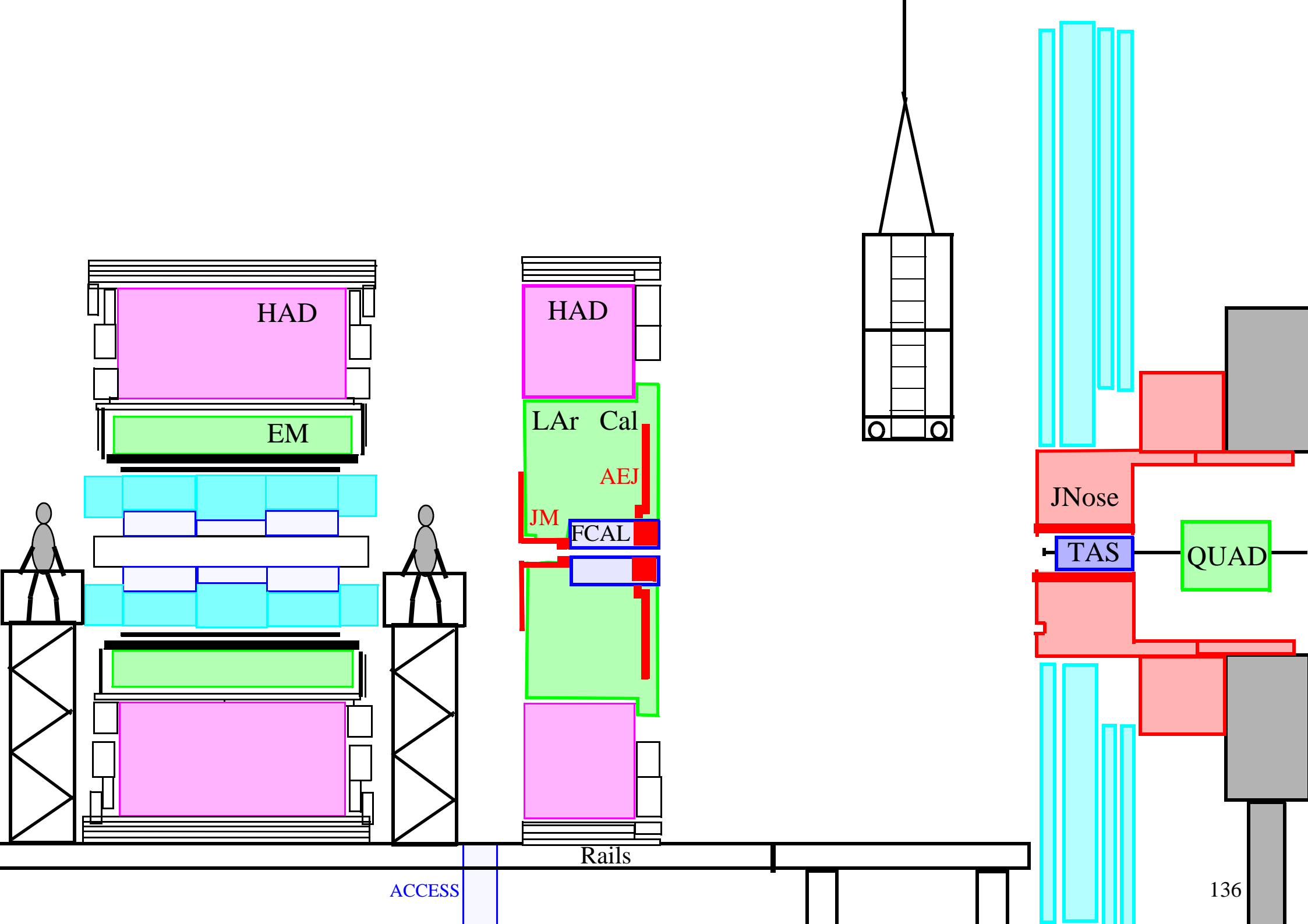

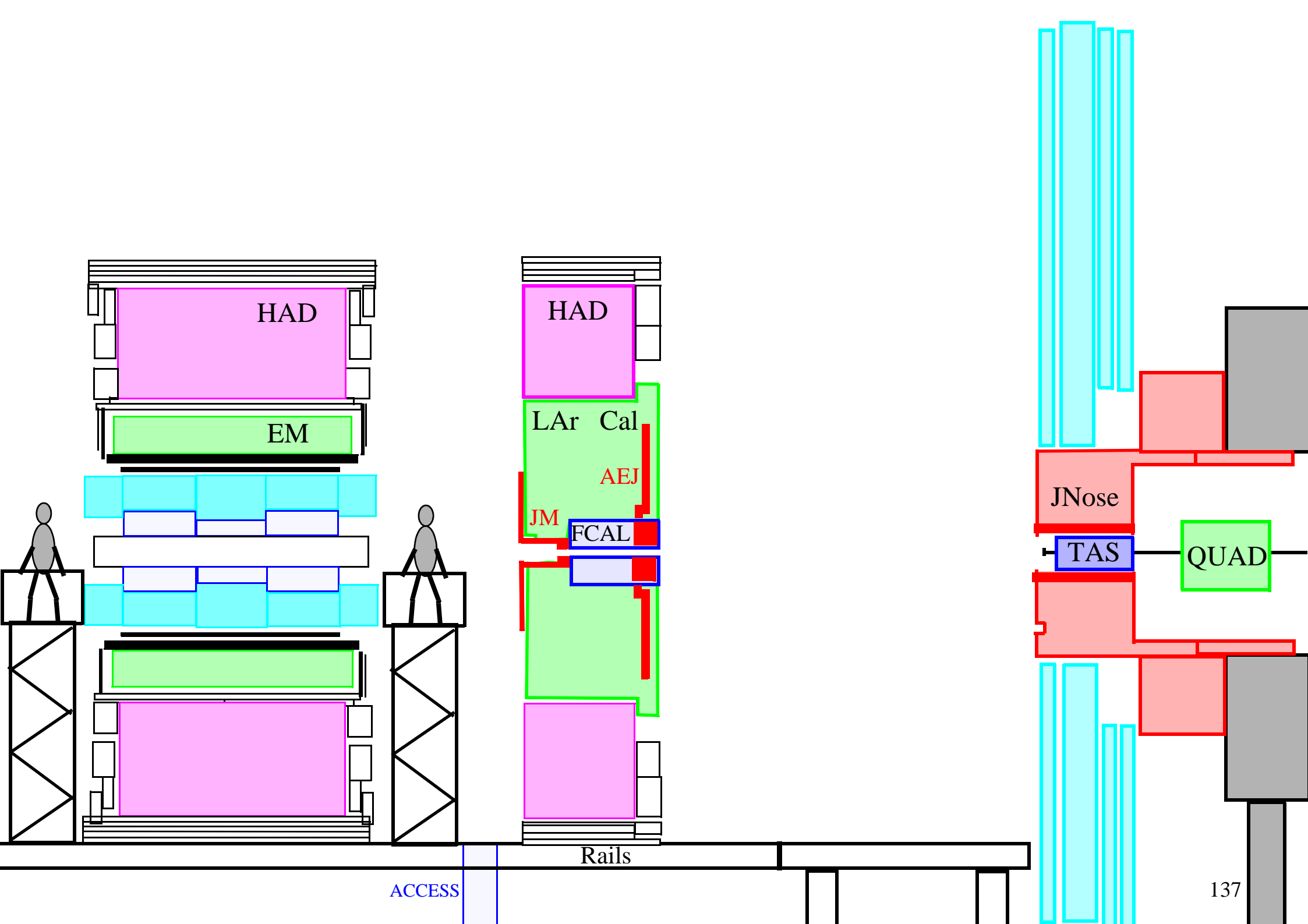

HAD

EM

HAD

LAr Cal

AEJ

JM

FCAL

JNose

TAS

QUAD

Rails

ACCESS

137

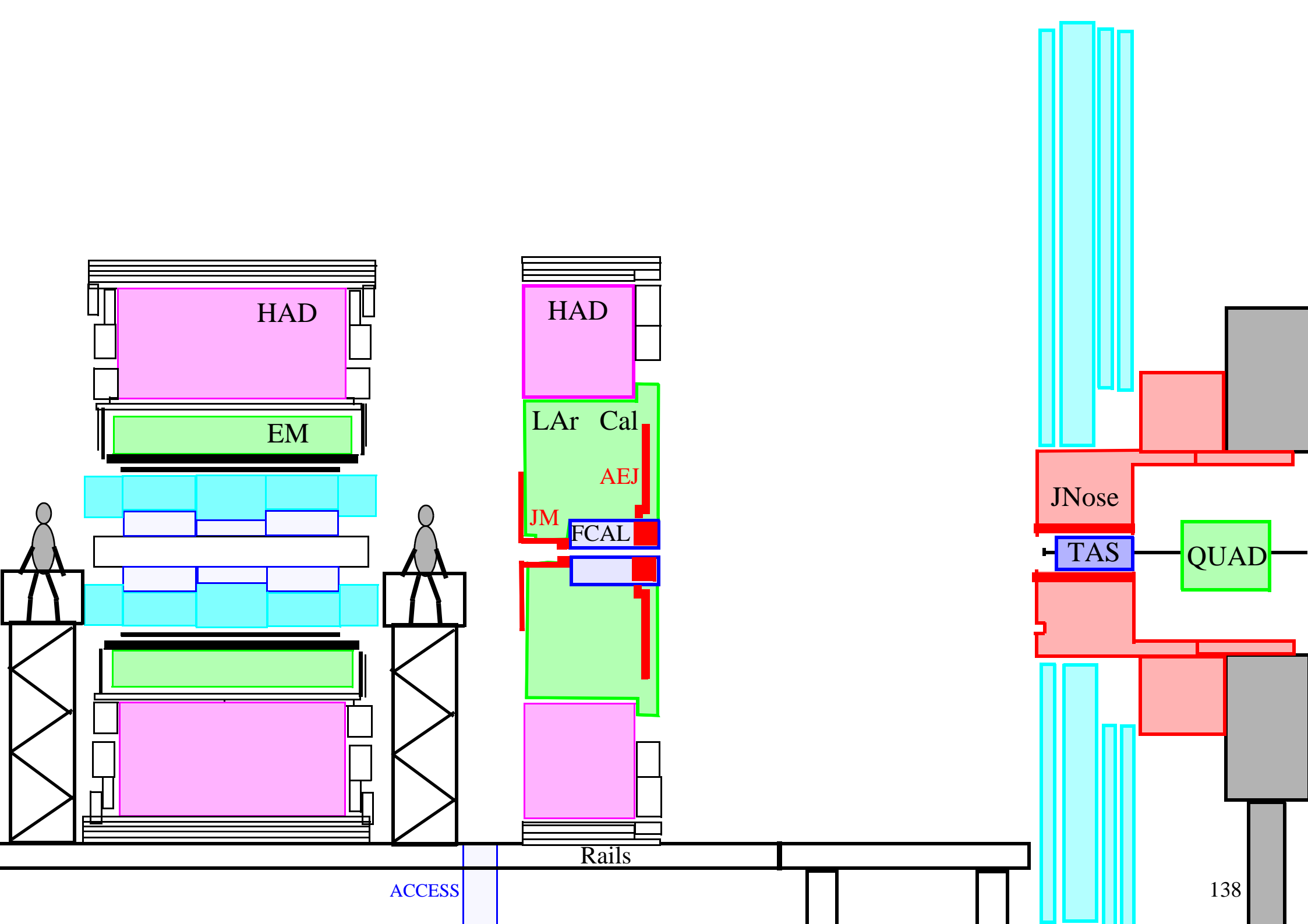

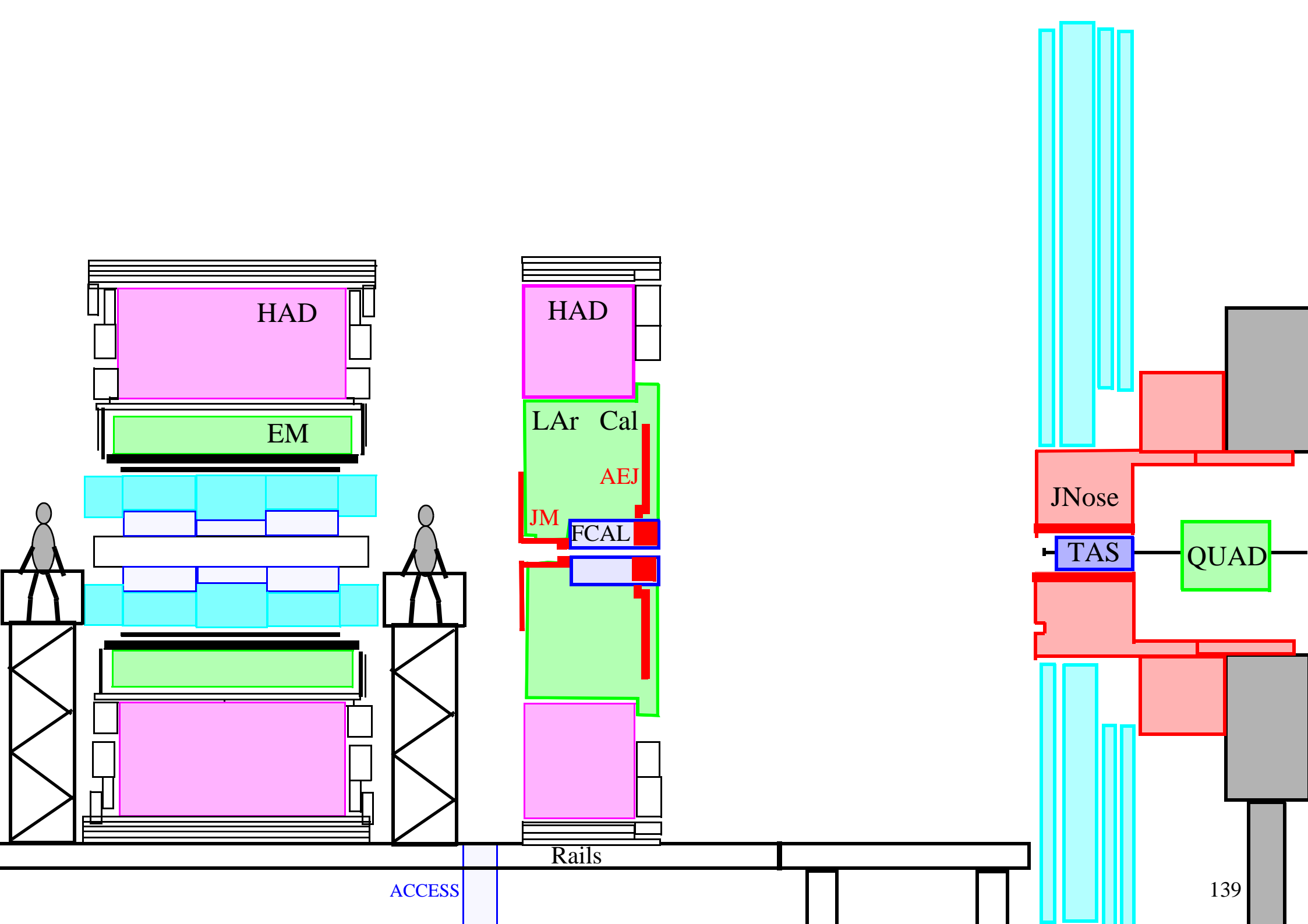

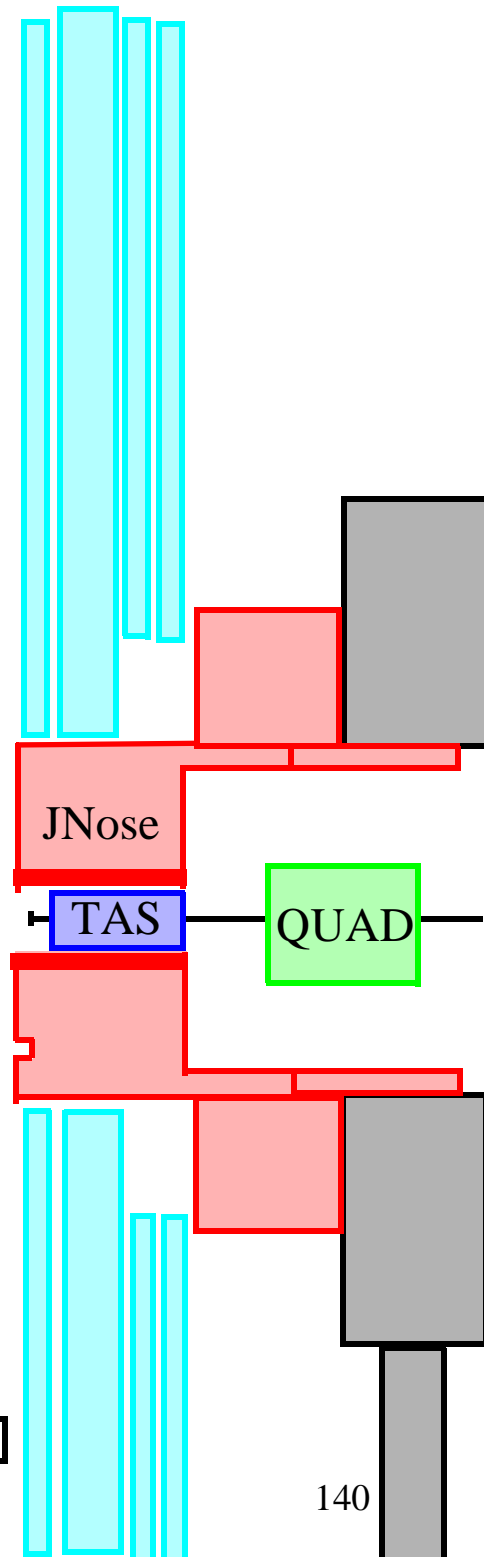
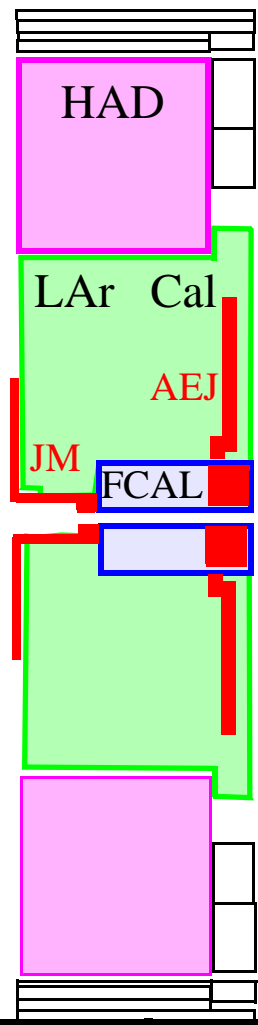
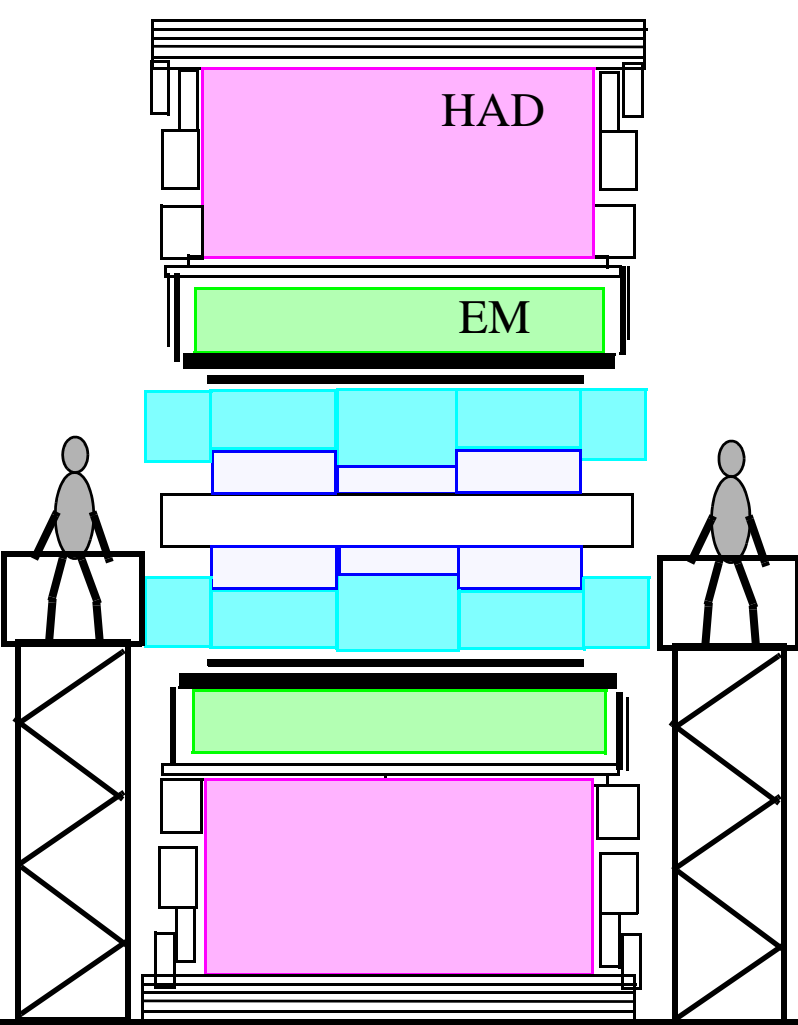

Rails

ACCESS

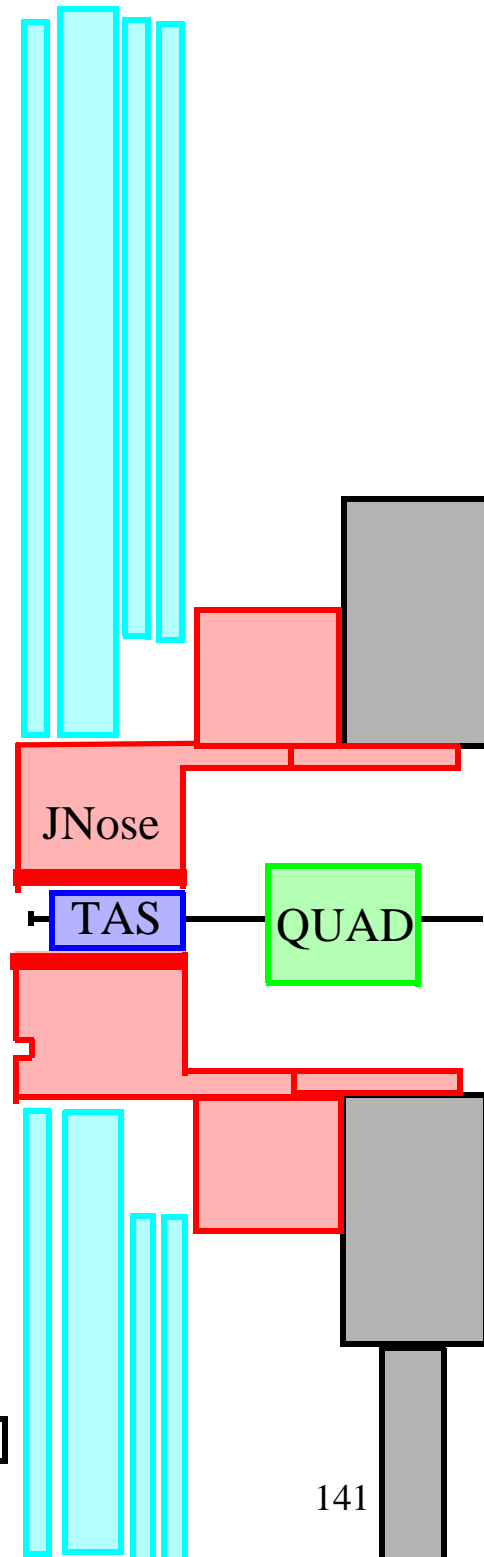
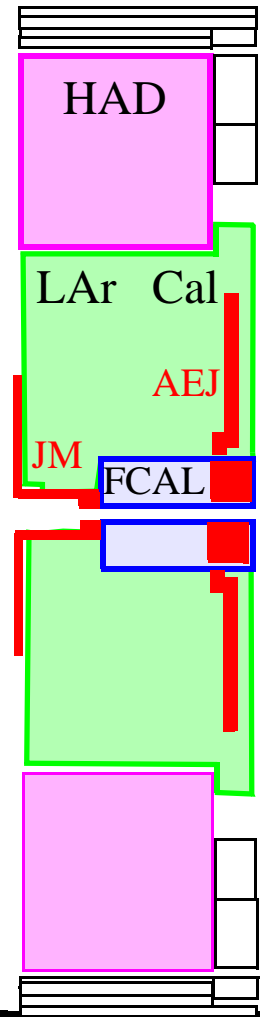
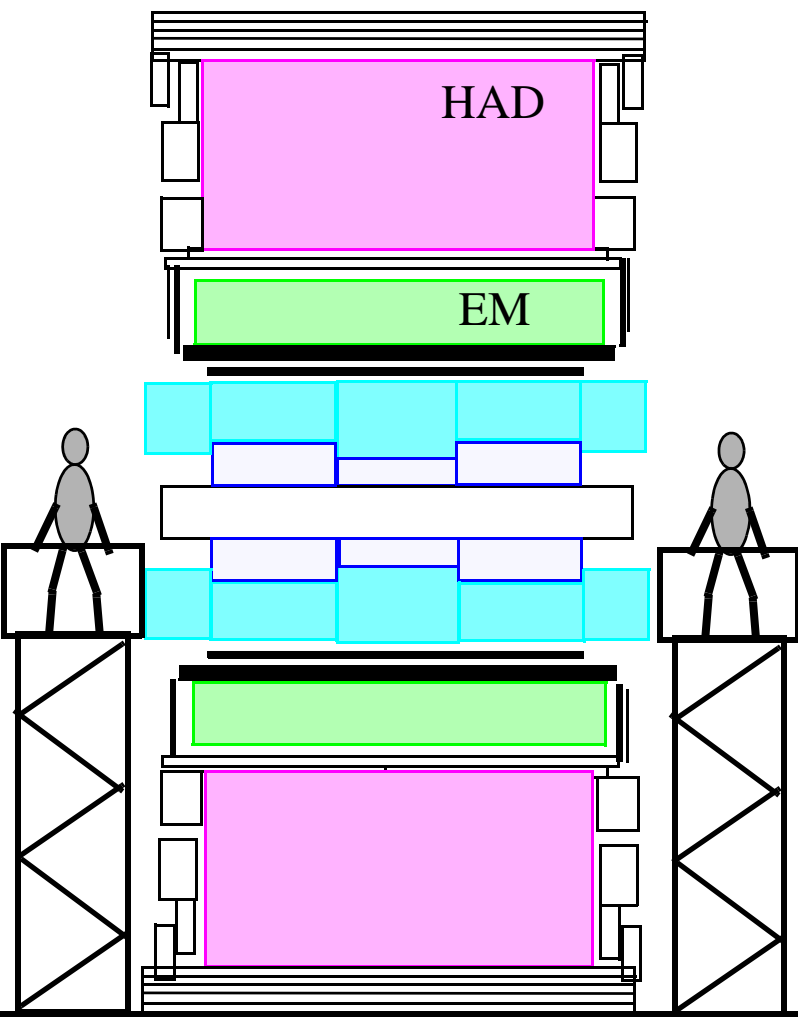

Rails

ACCESS

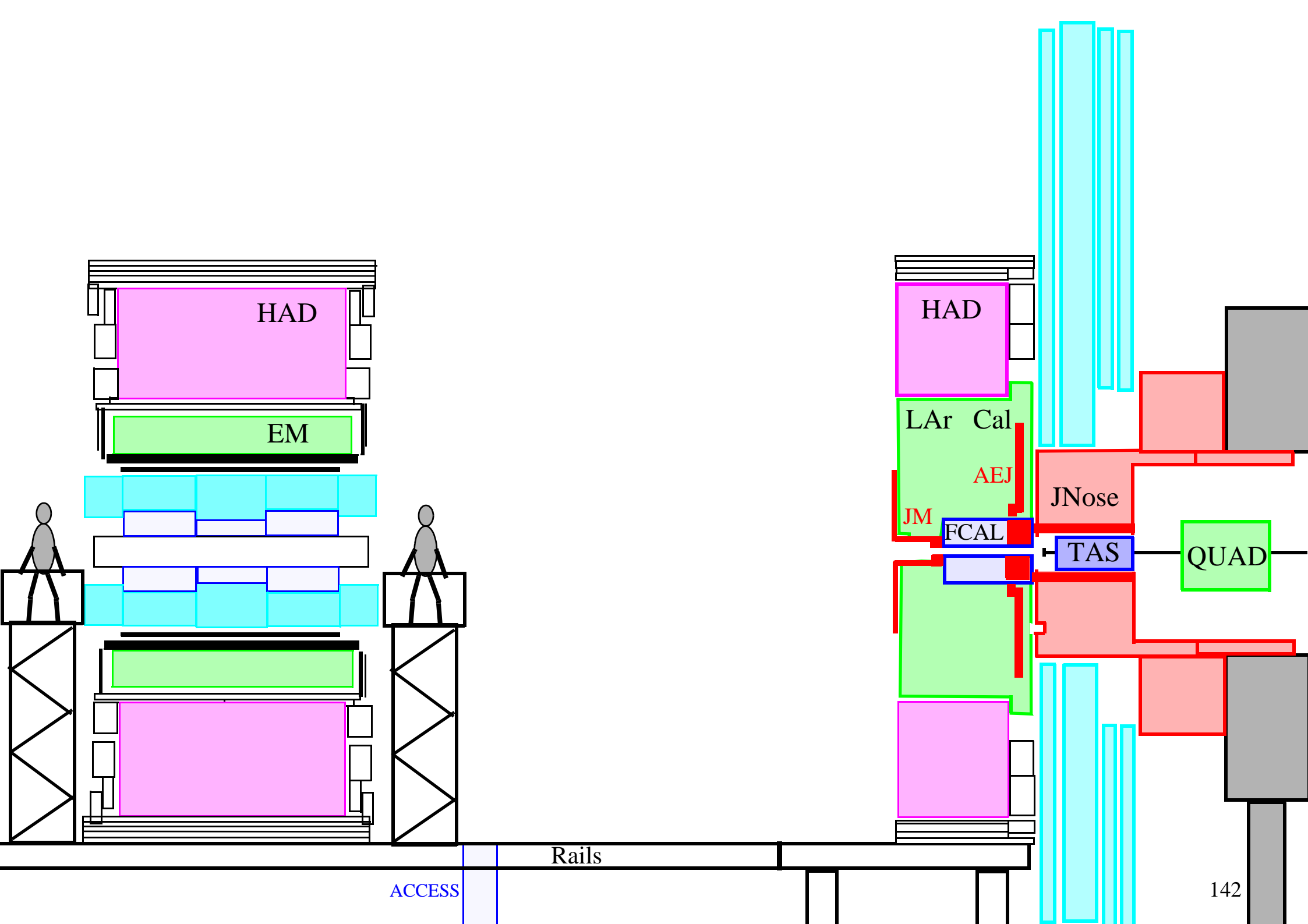

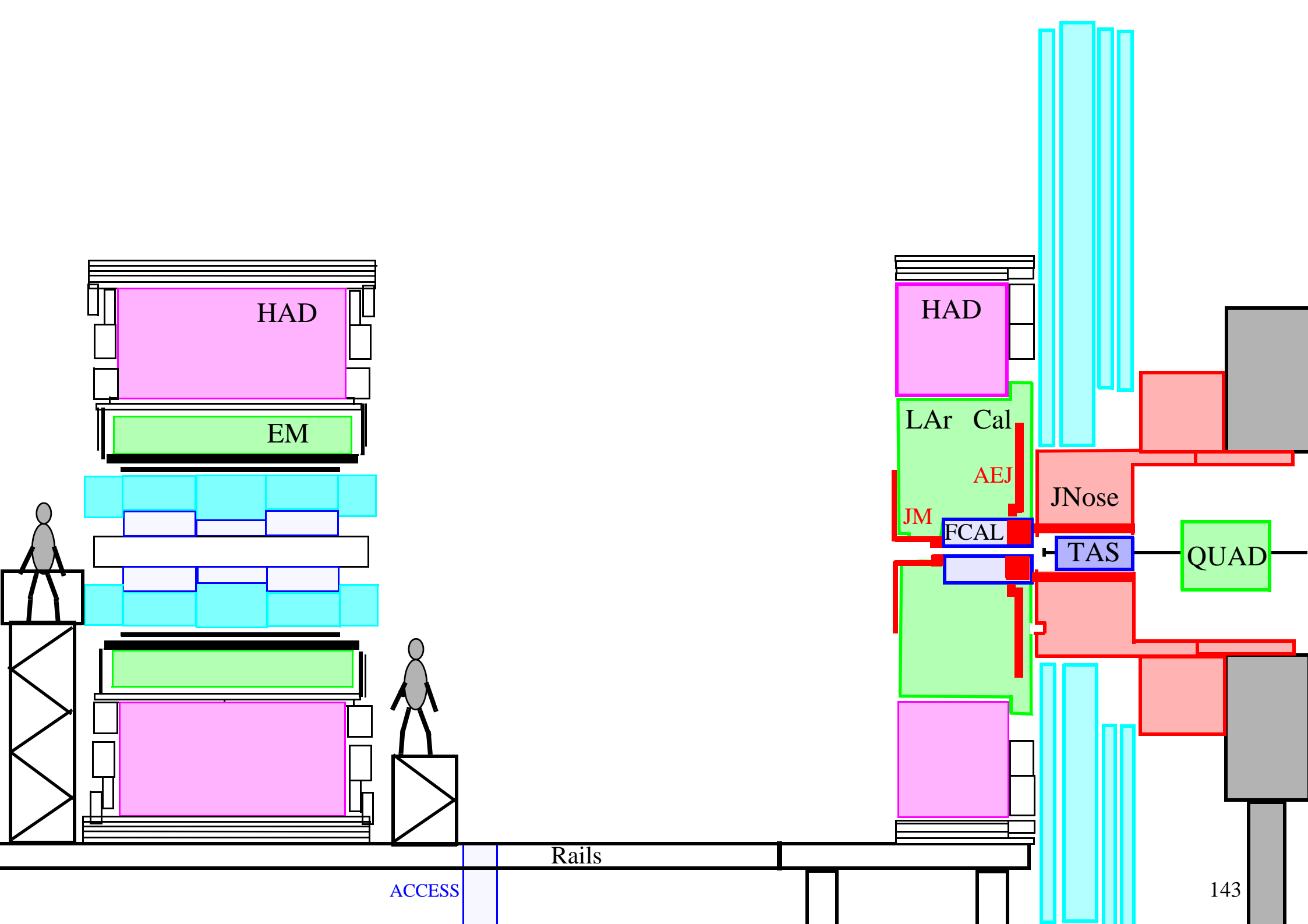

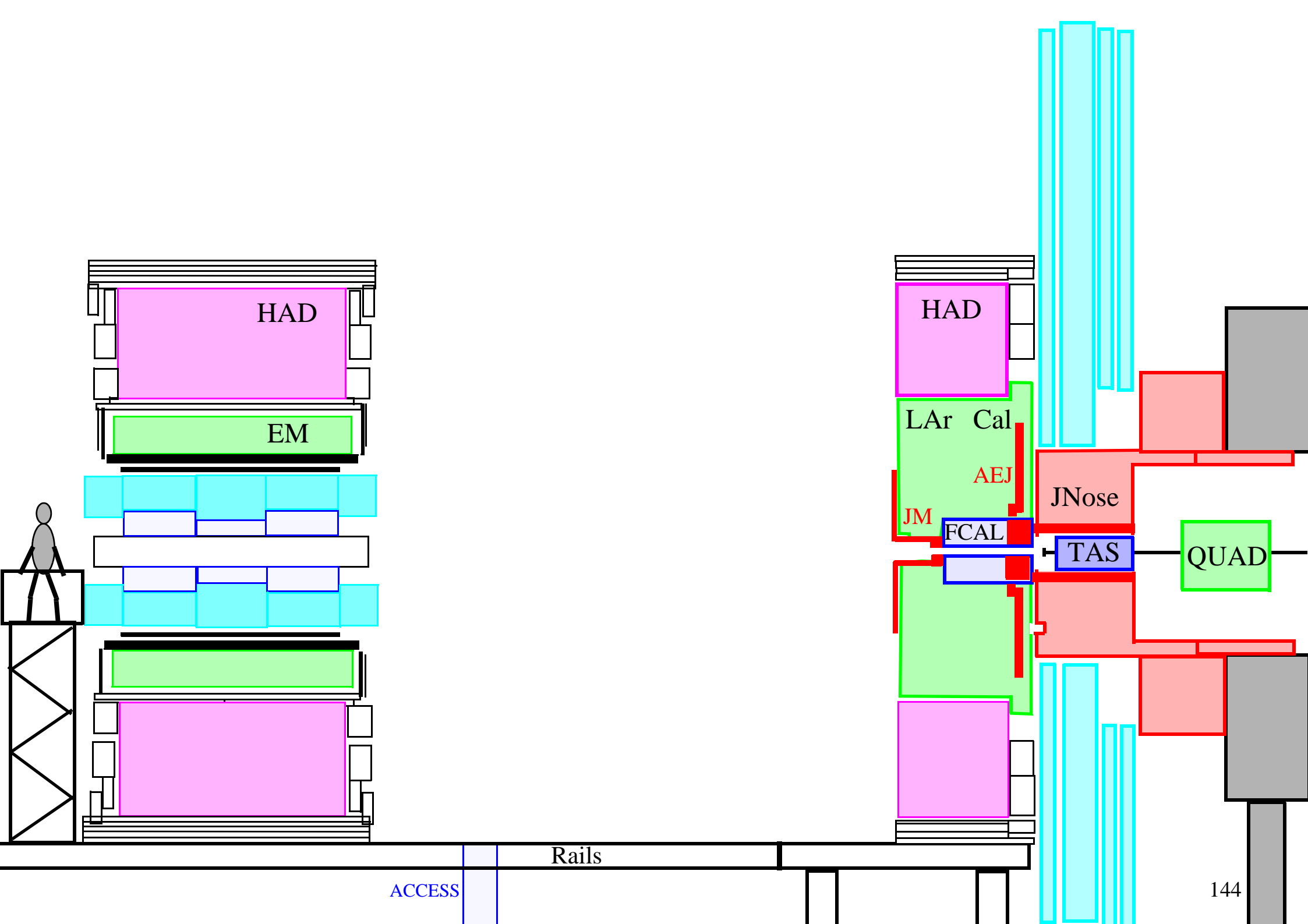

HAD

EM

HAD

LAr Cal

AEJ

JM

FCAL

JNose

TAS

QUAD

Rails

ACCESS

March 2007

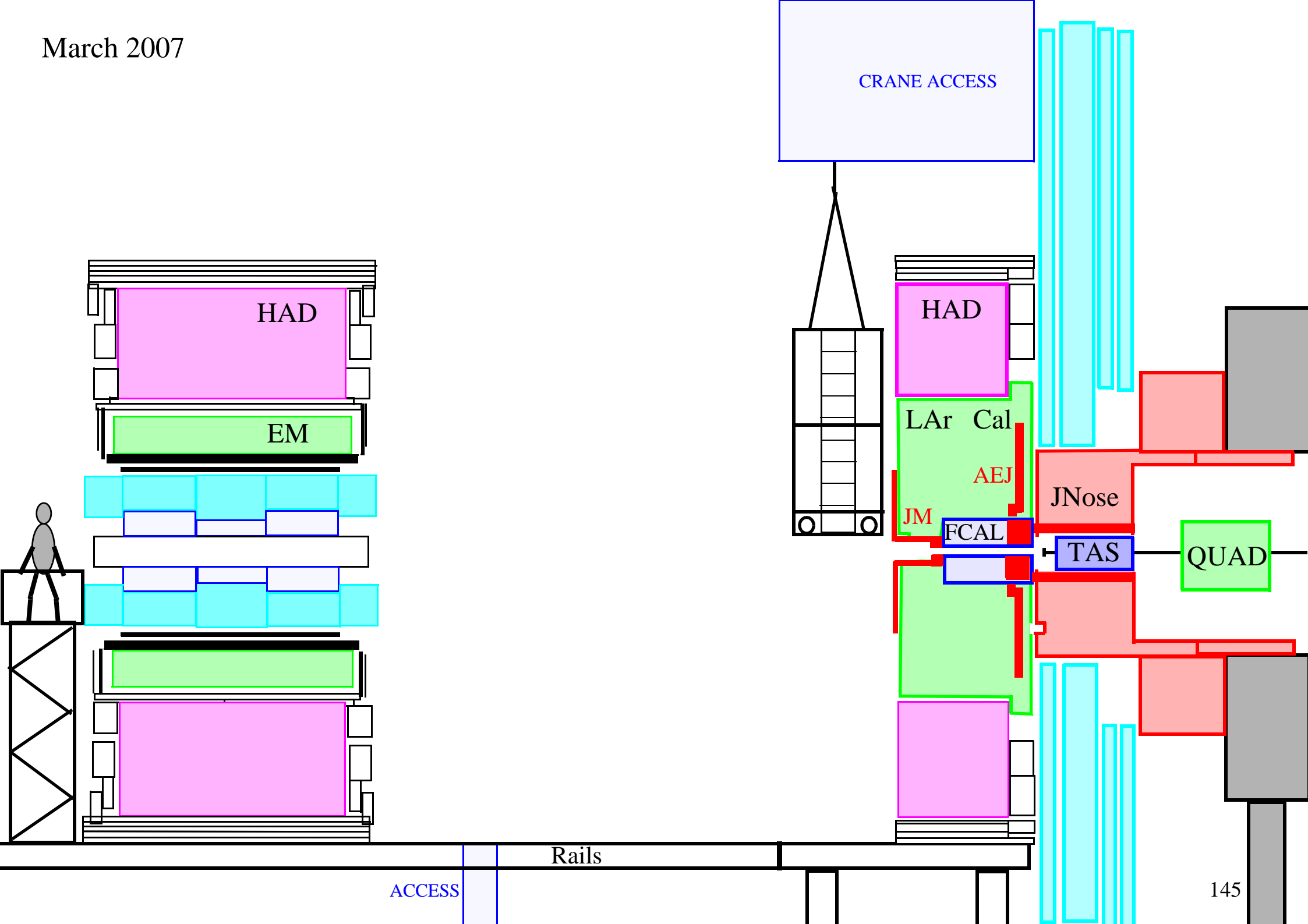

CRANE ACCESS

HAD

EM

HAD

LAr Cal

AEJ

JM

FCAL

JNose

TAS

QUAD

Rails

ACCESS

145

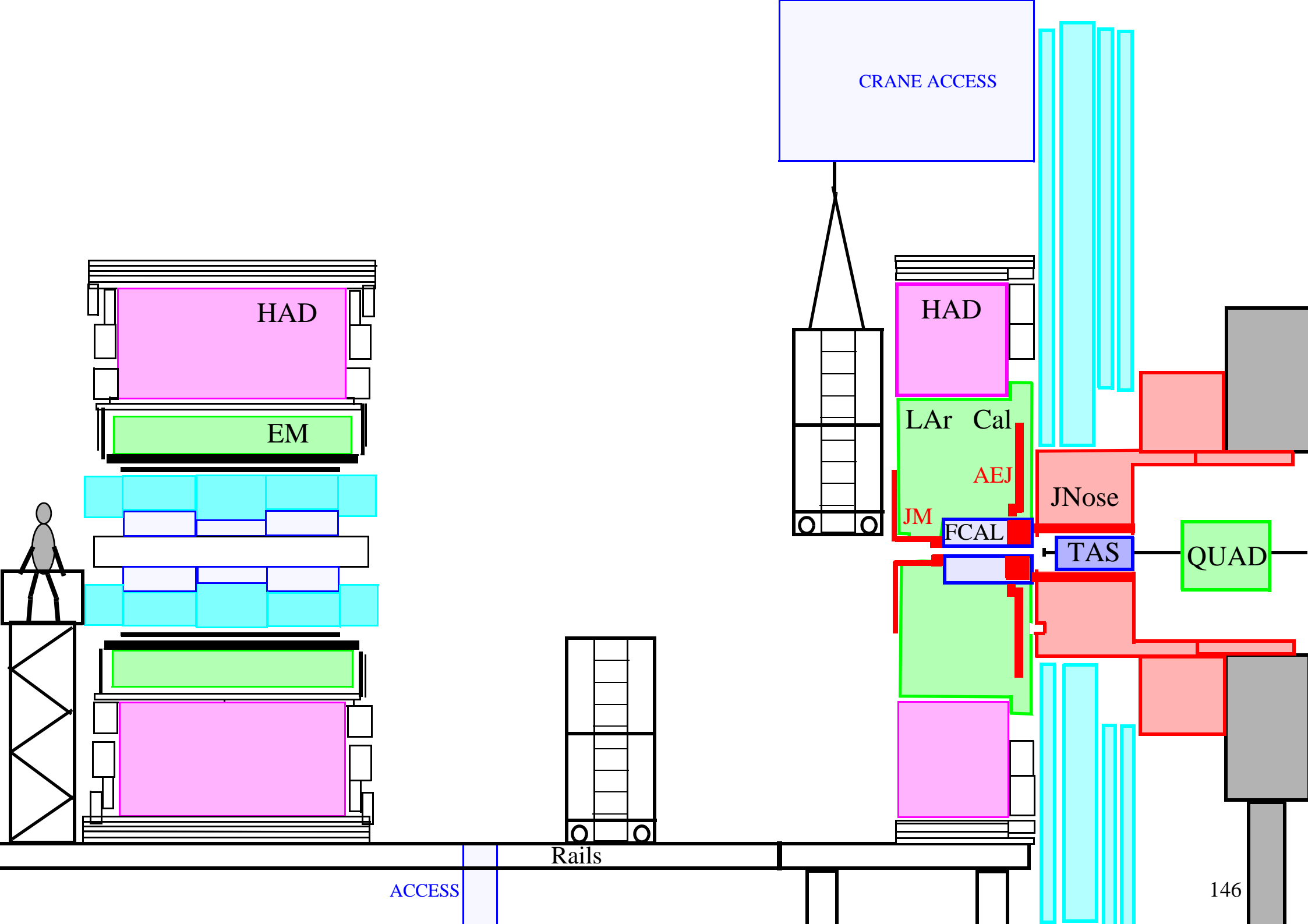

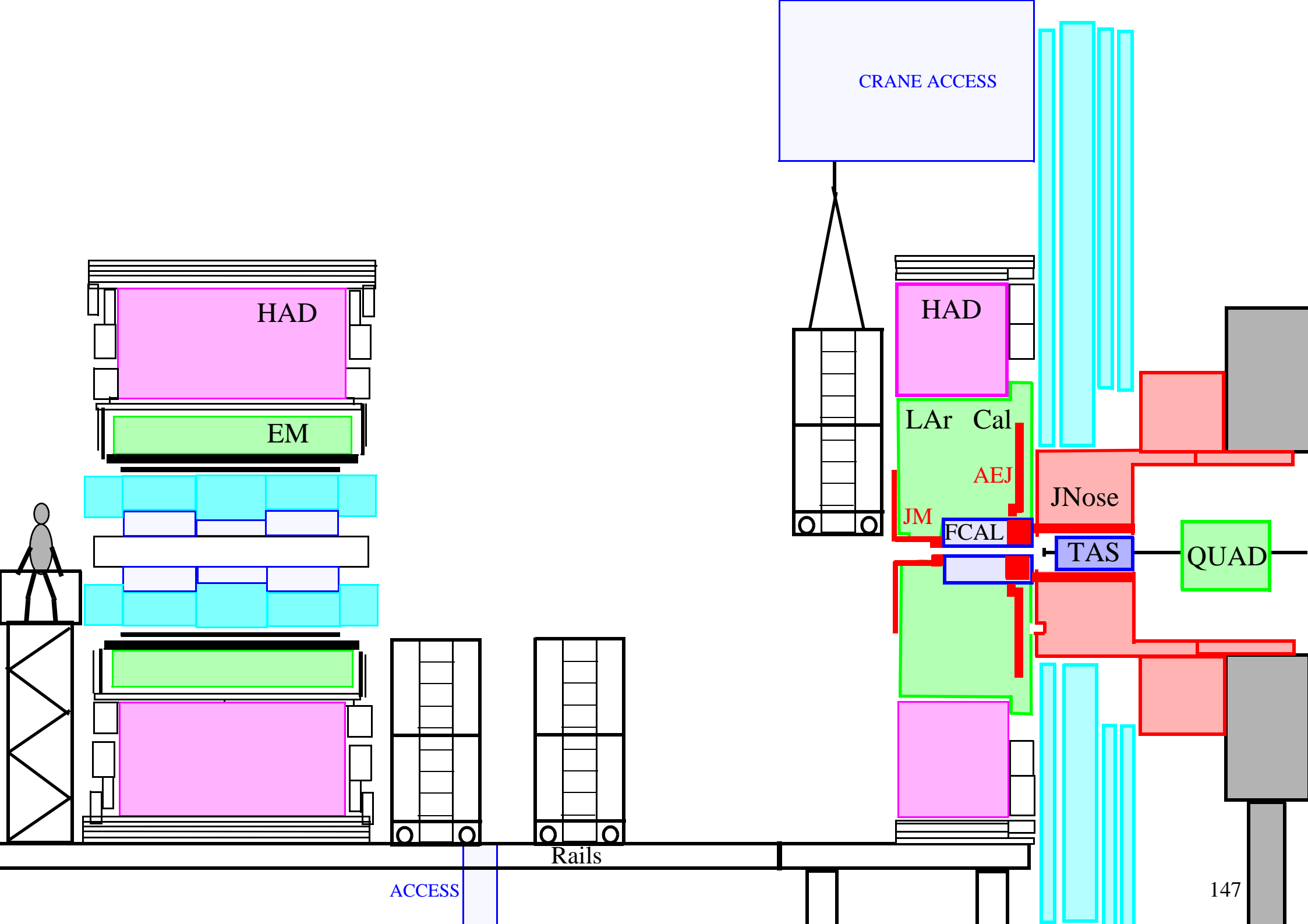

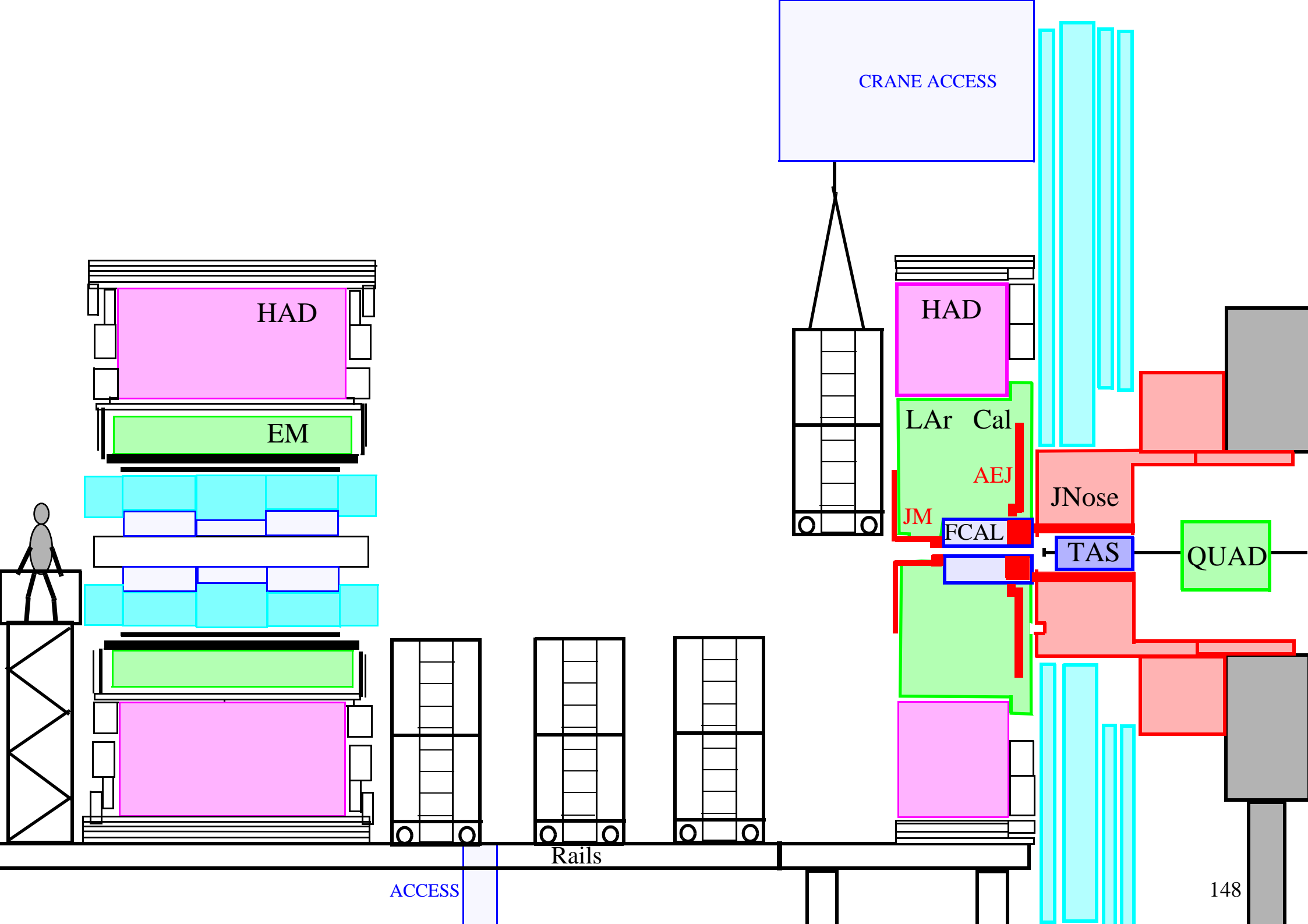

HAD

EM



CRANE ACCESS

HAD

LAr Cal

AEJ

JM

FCAL

JNose

TAS

QUAD

Rails

ACCESS

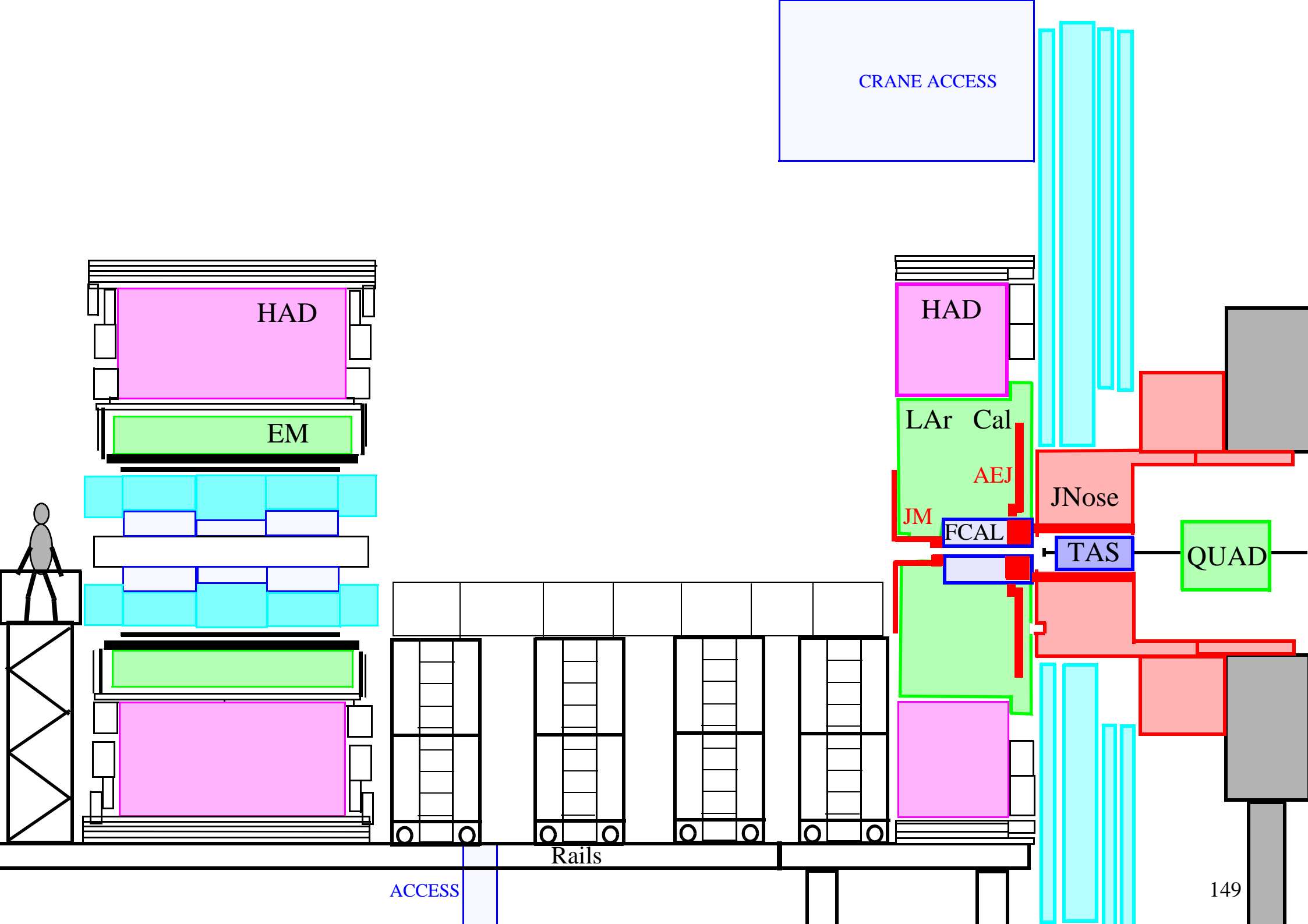

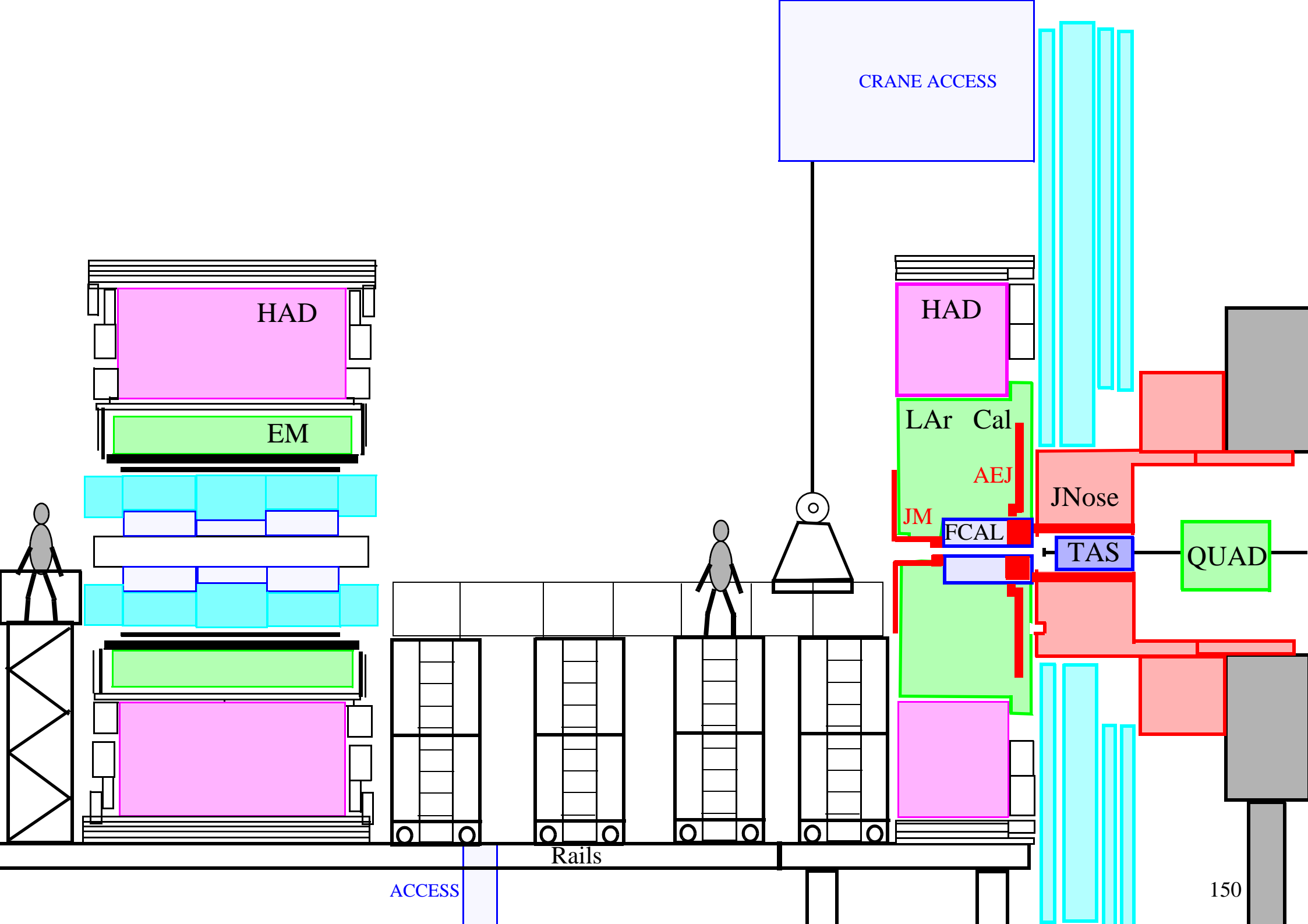

CRANE ACCESS

HAD

EM

HAD

LAr Cal

AEJ

JM

FCAL

JNose

TAS

QUAD

Rails

ACCESS

150

Is scaffolding on this side sufficient ?

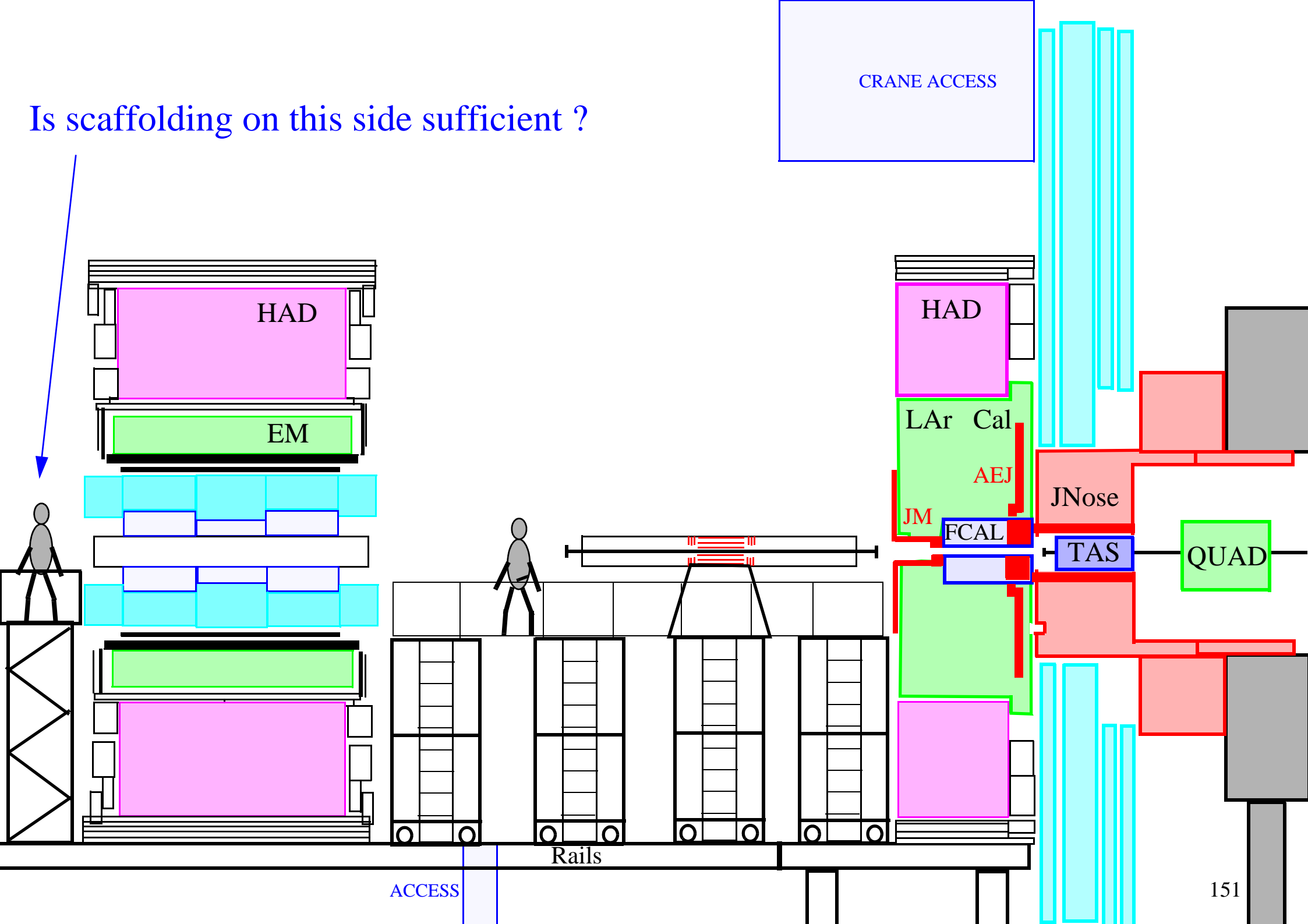

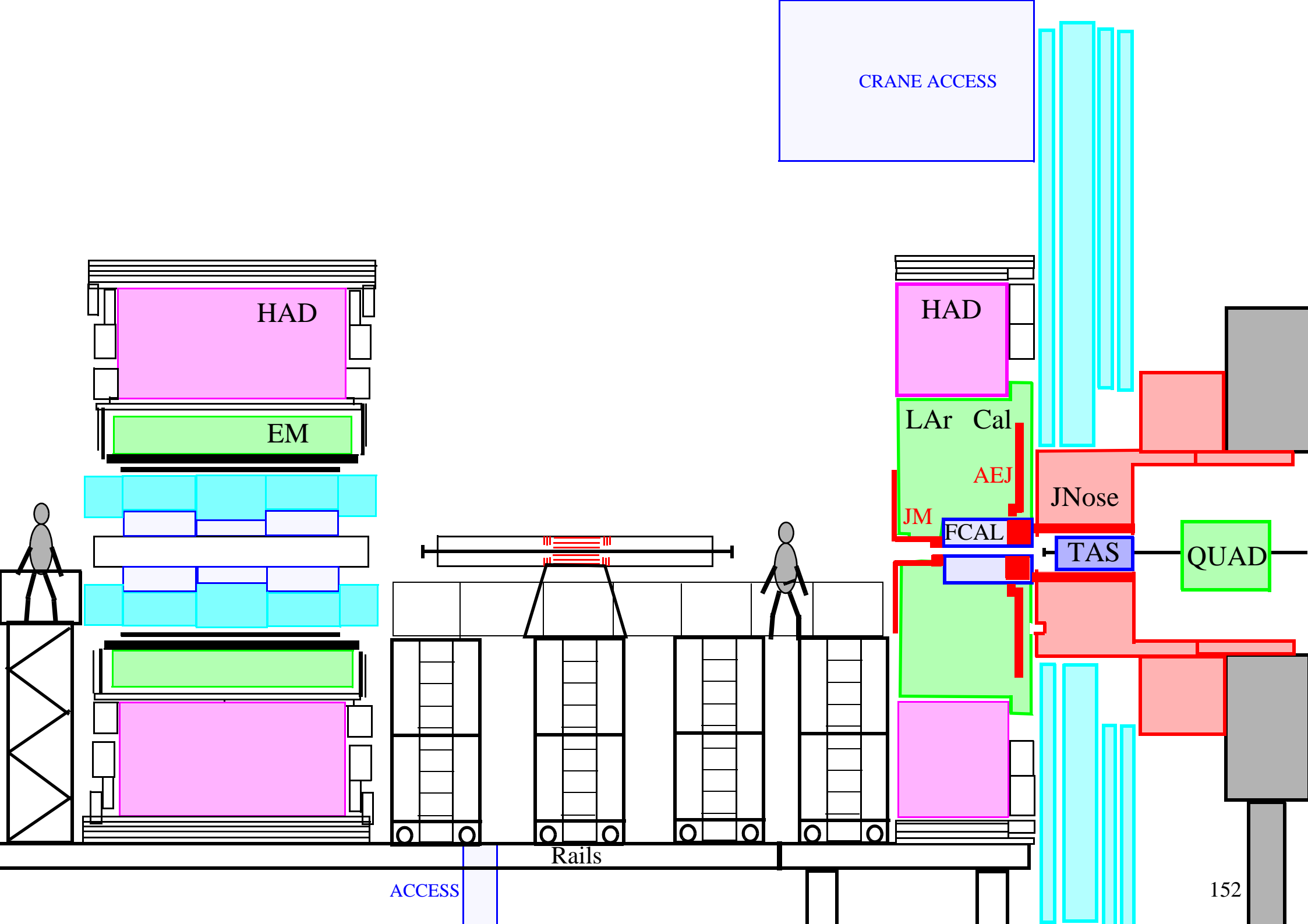

CRANE ACCESS

HAD

EM

HAD

LAr Cal

AEJ

JM

FCAL

JNose

TAS

QUAD

Rails

ACCESS

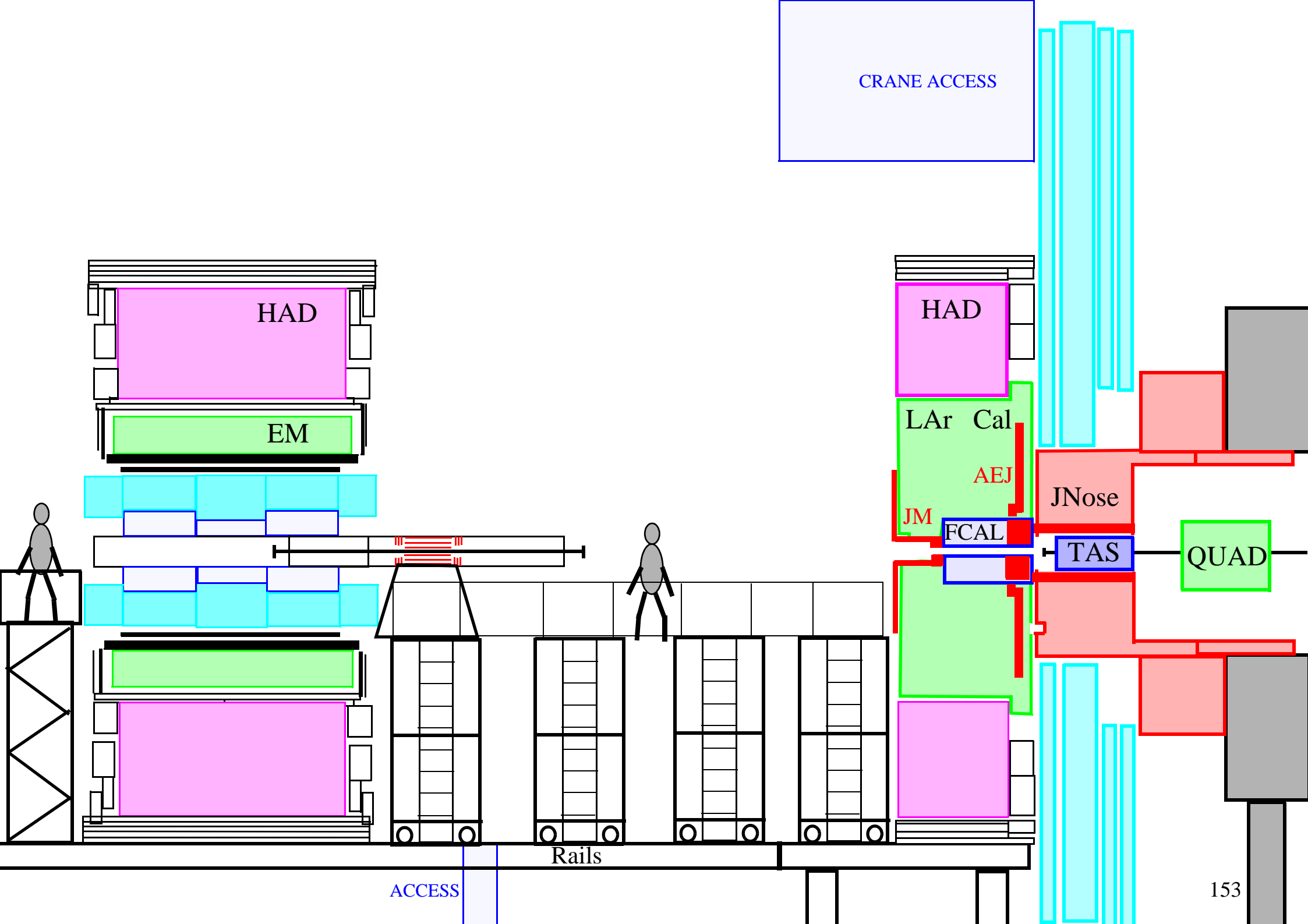

CRANE ACCESS

HAD

EM

HAD

LAr Cal

AEJ

JM

FCAL

JNose

TAS

QUAD

Rails

ACCESS

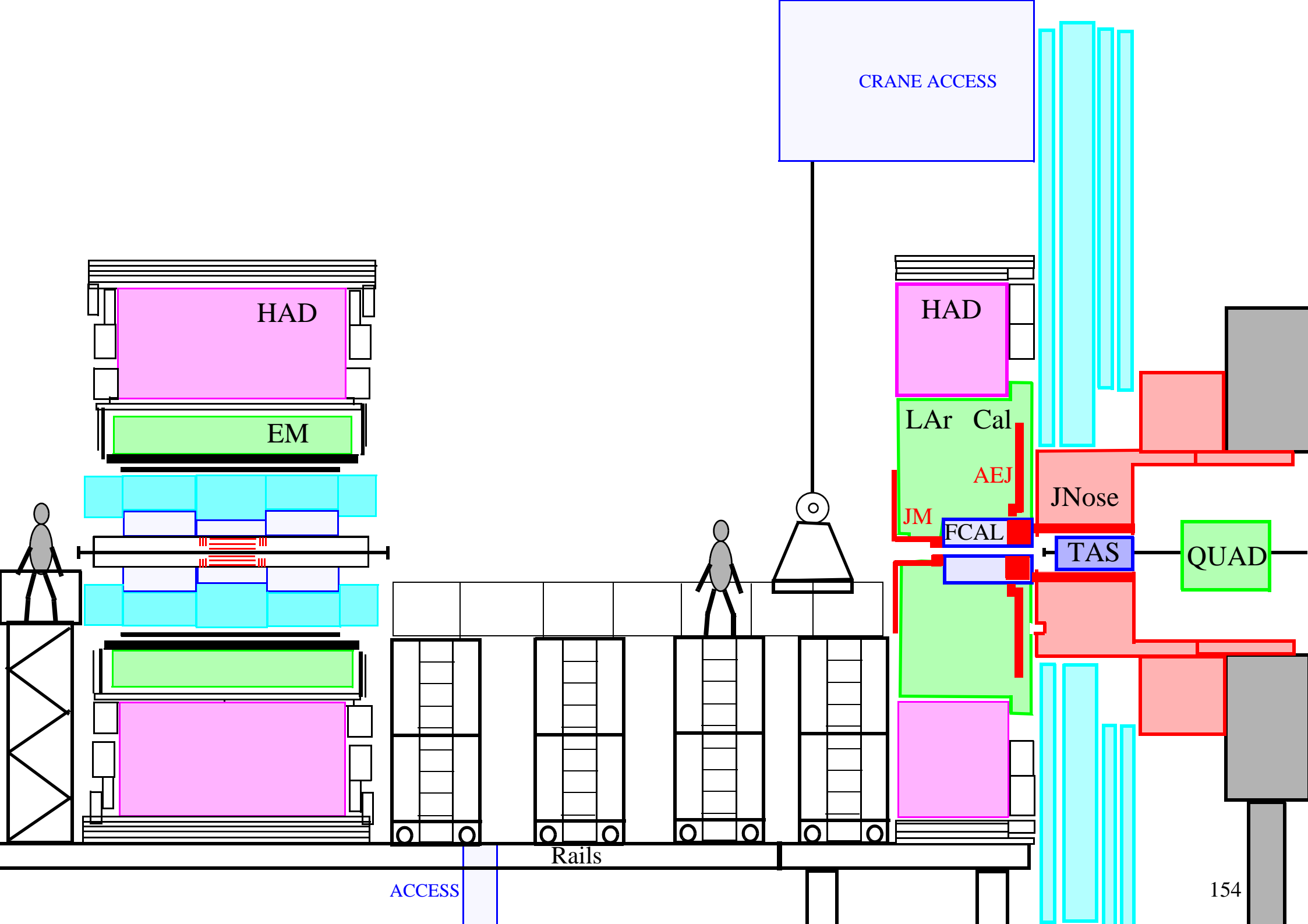

ACCESS

Rails

CRANE ACCESS

HAD

EM

HAD

LAr Cal

AEJ

JM

FCAL

JNose

TAS

QUAD

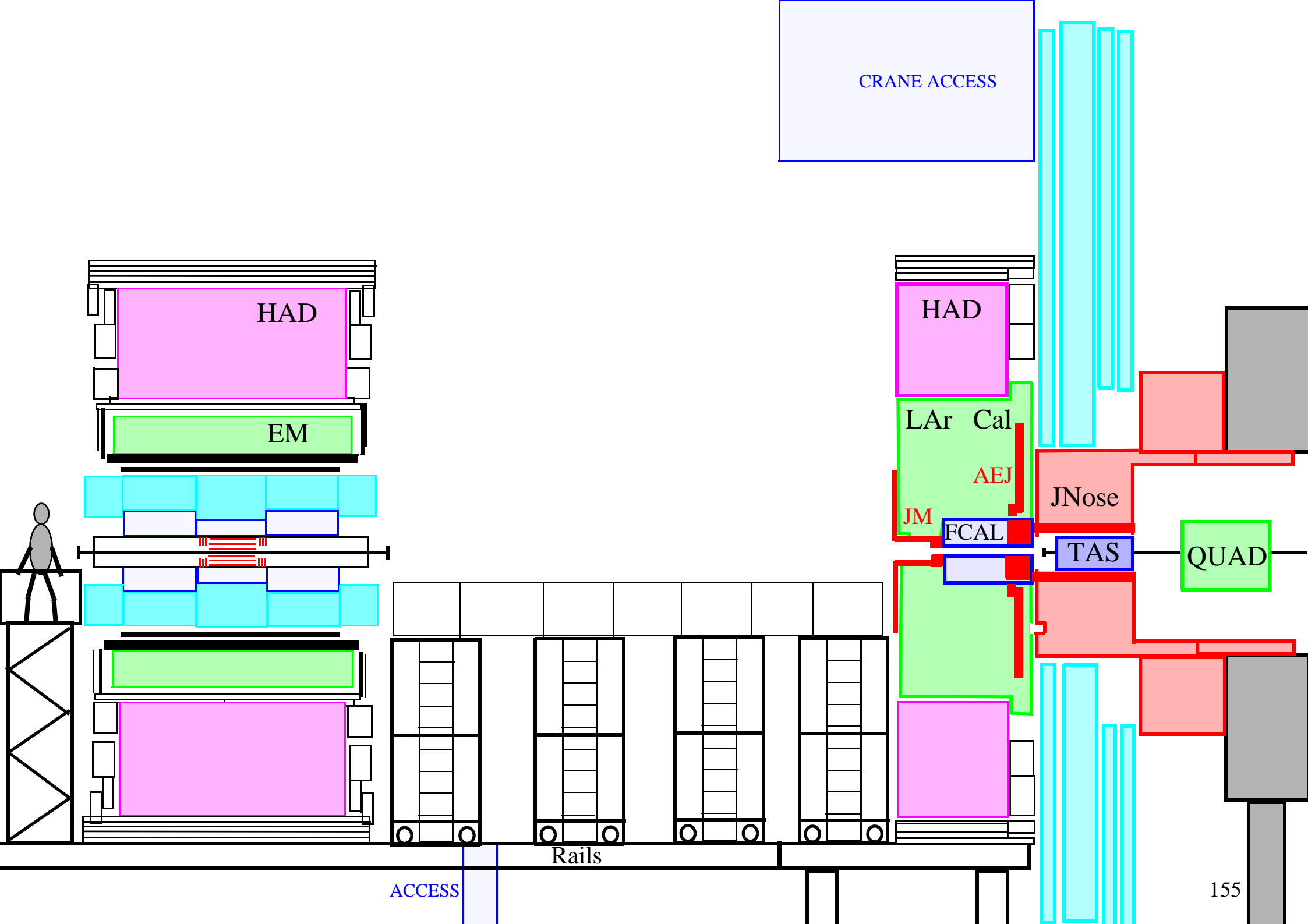

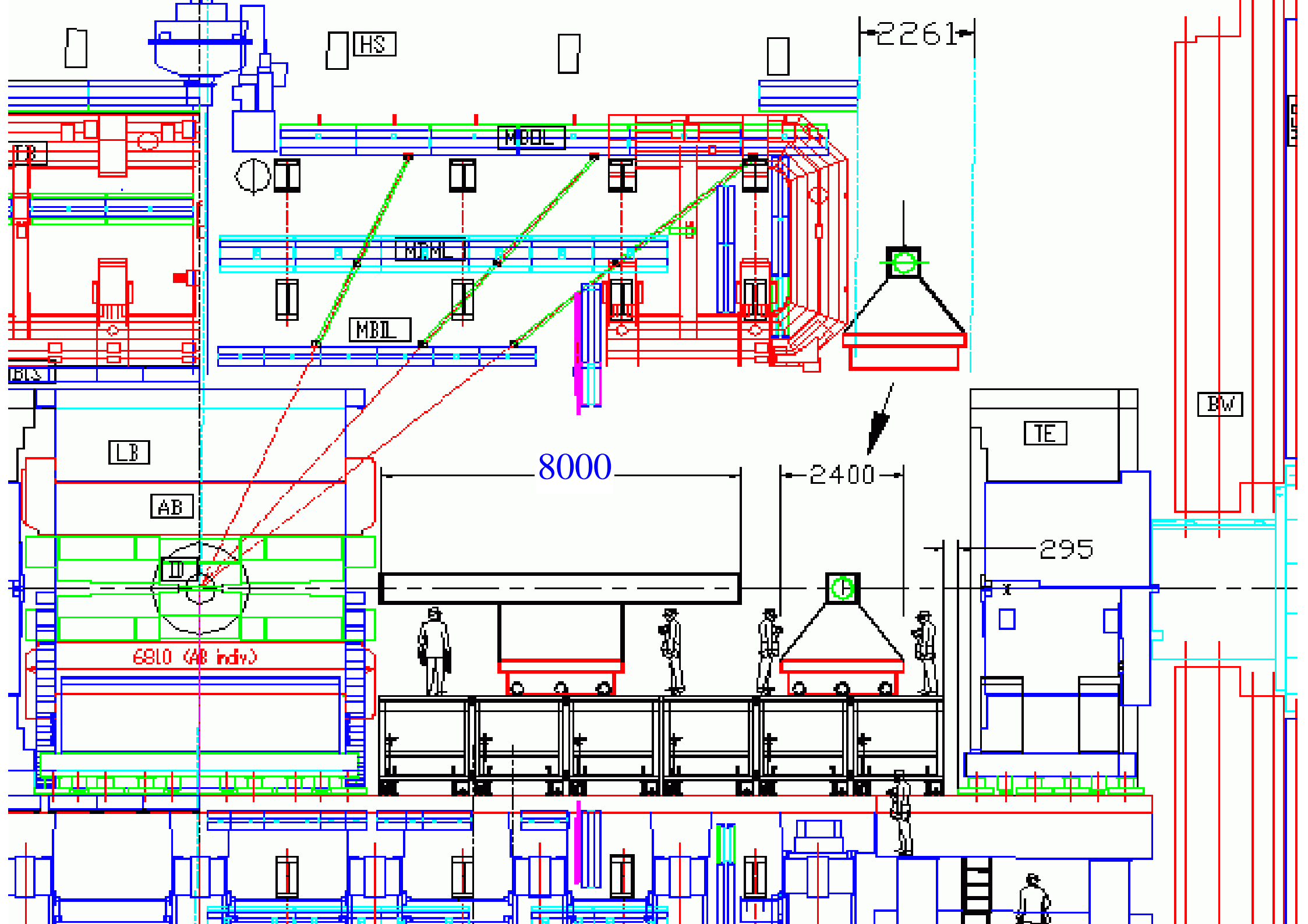

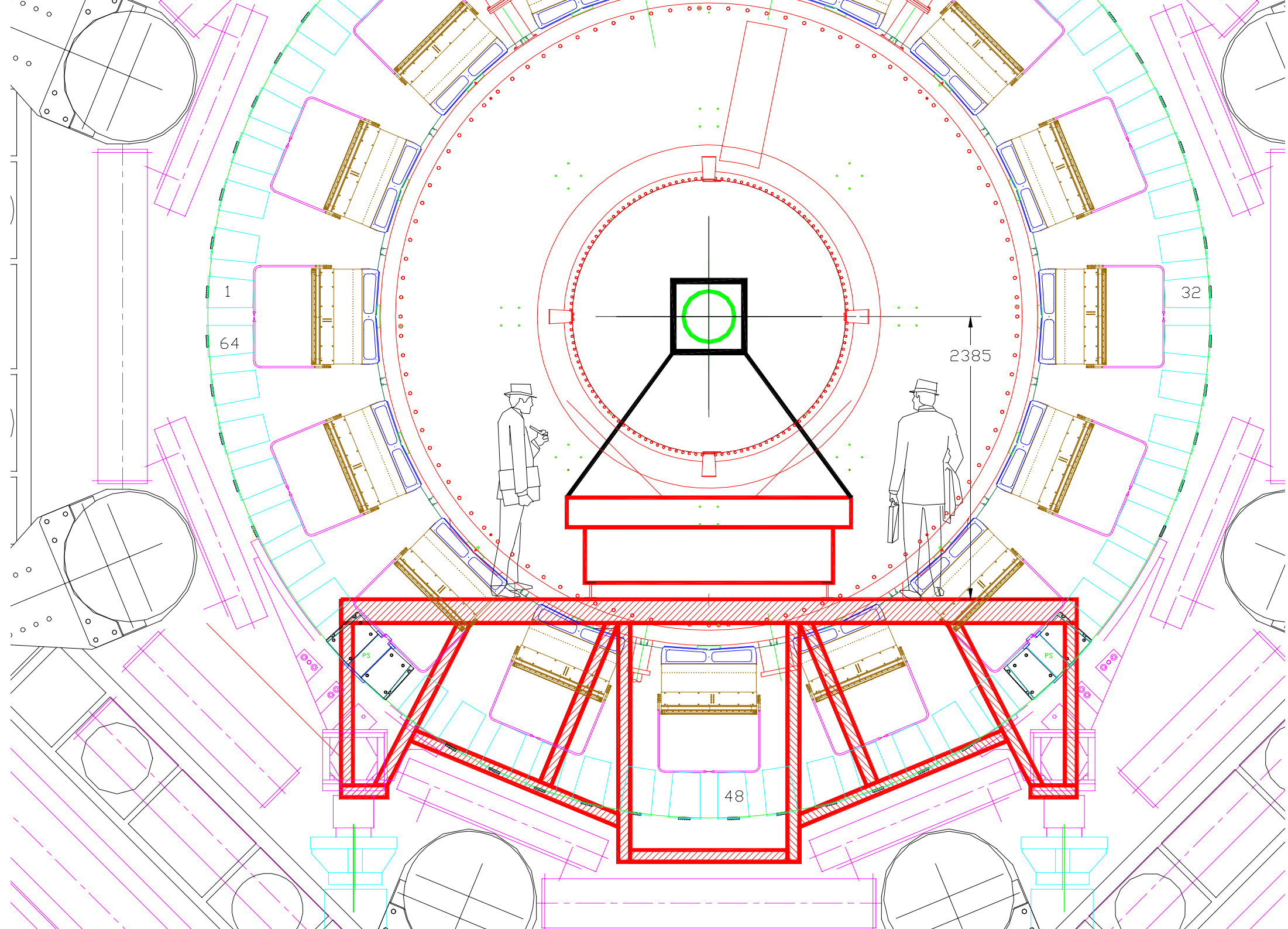

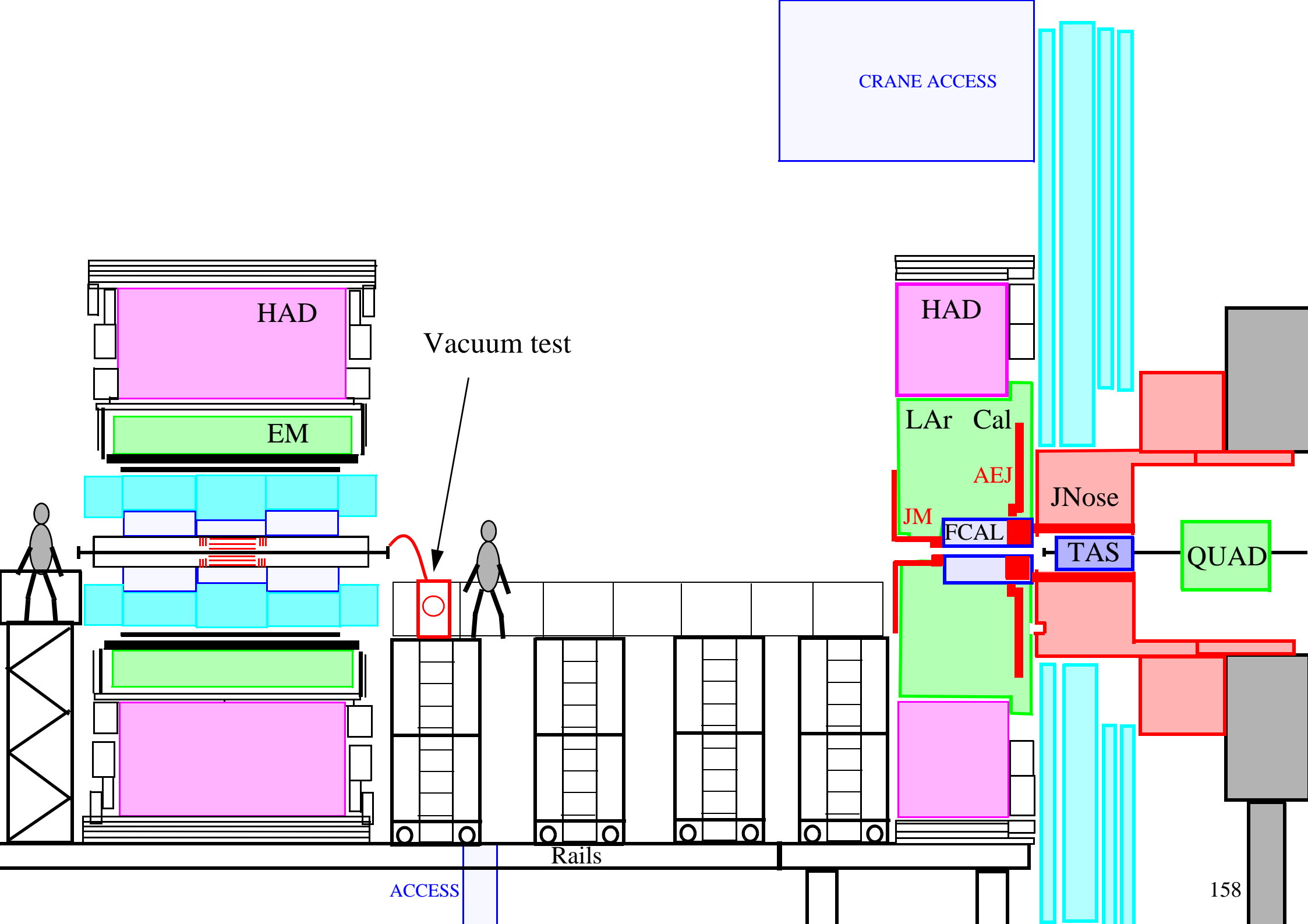

CRANE ACCESS

HAD

EM

Vacuum test

HAD

LAr Cal

AEJ

JM

FCAL

JNose

TAS

QUAD

Rails

ACCESS

158

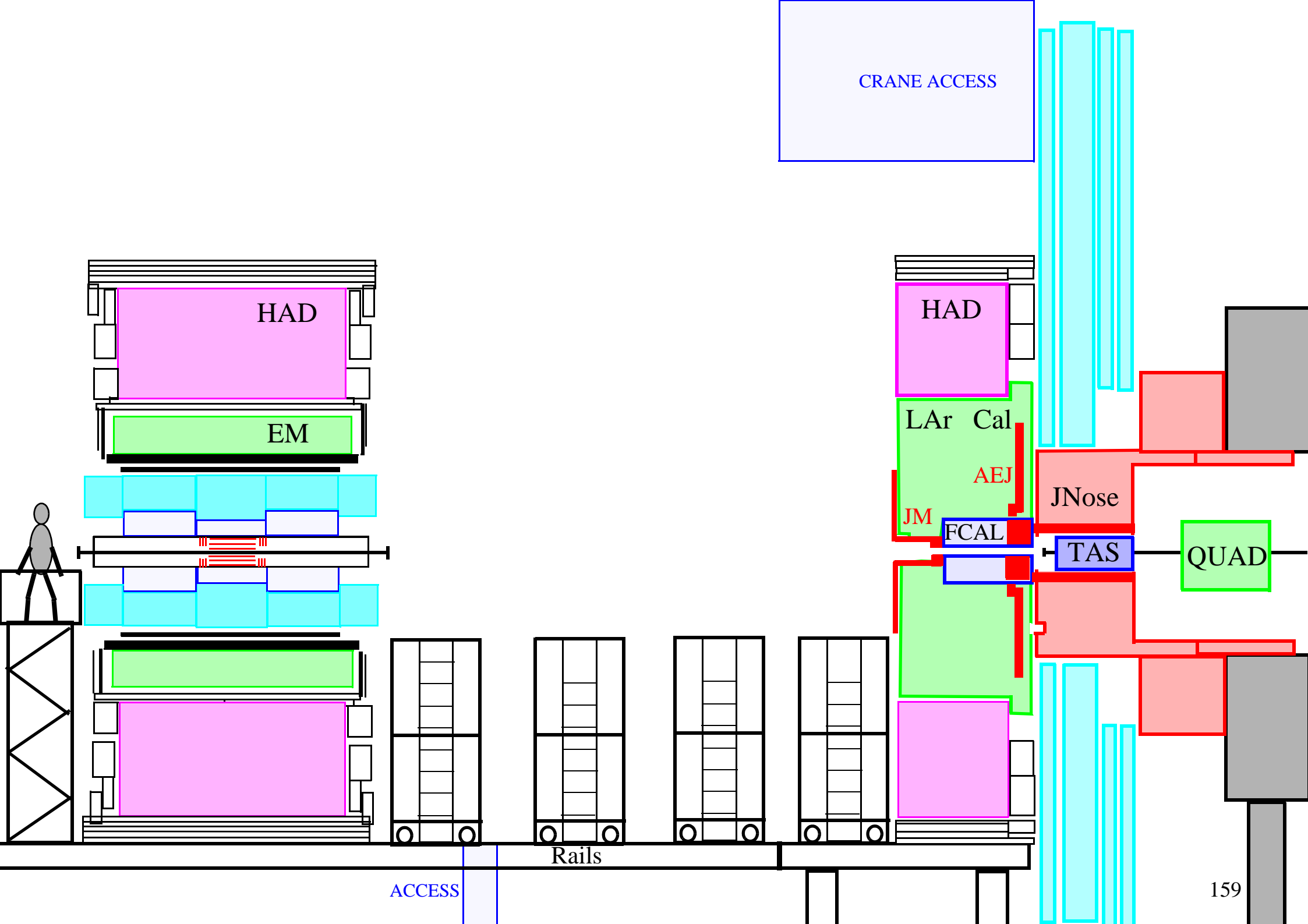

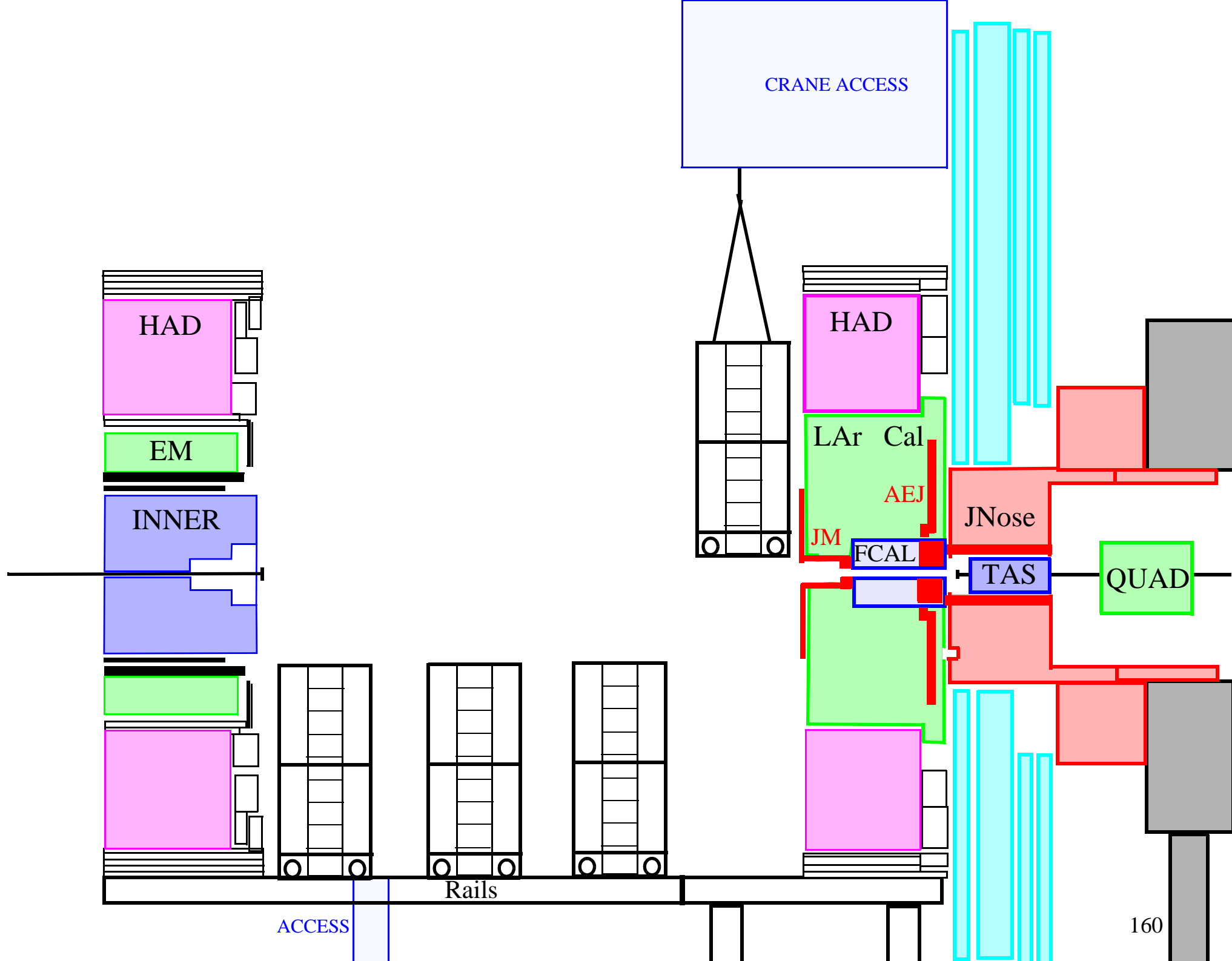

CRANE ACCESS

HAD

EM

INNER

HAD

LAr Cal

AEJ

JM

FCAL

JNose

TAS

QUAD

Rails

ACCESS

160

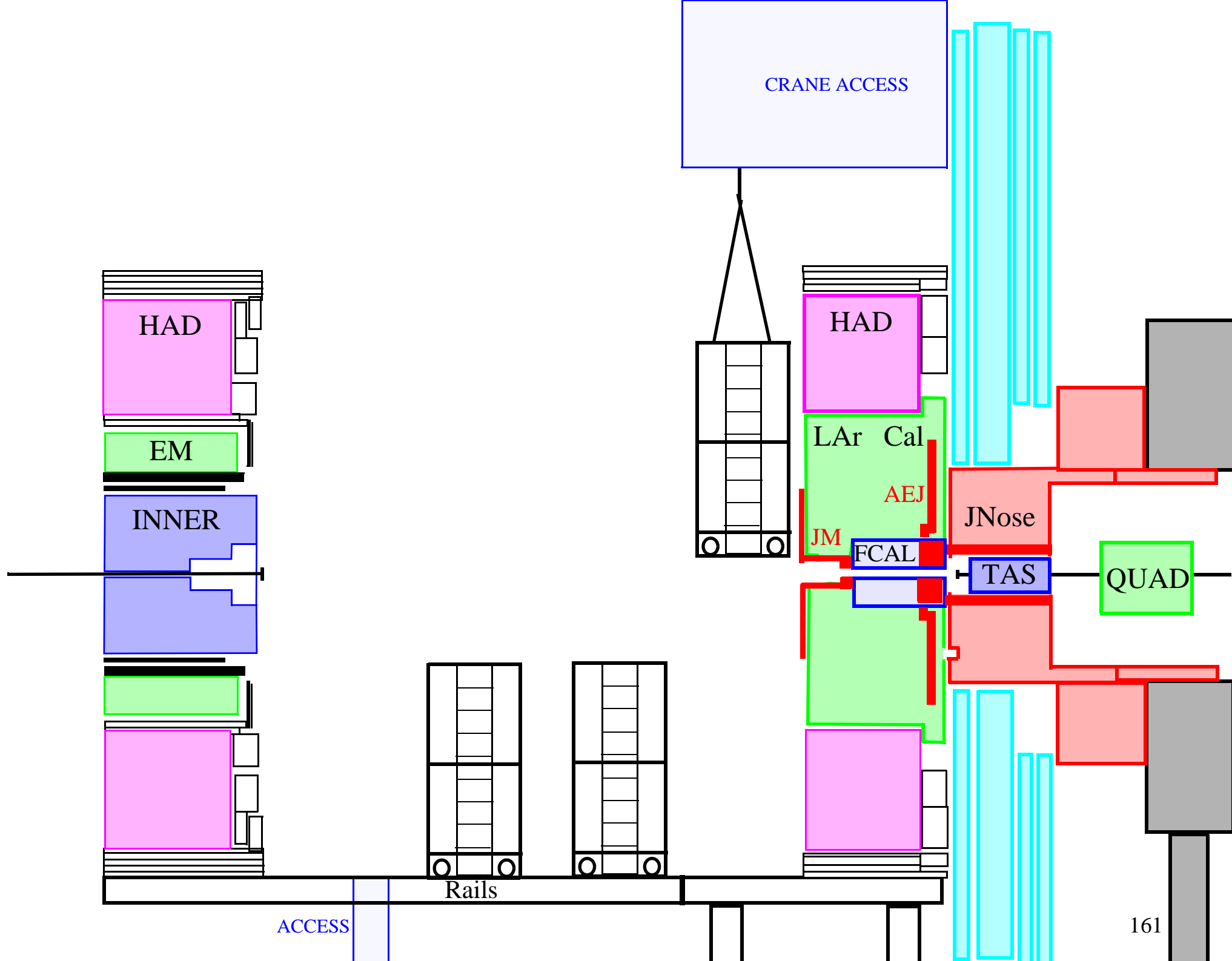

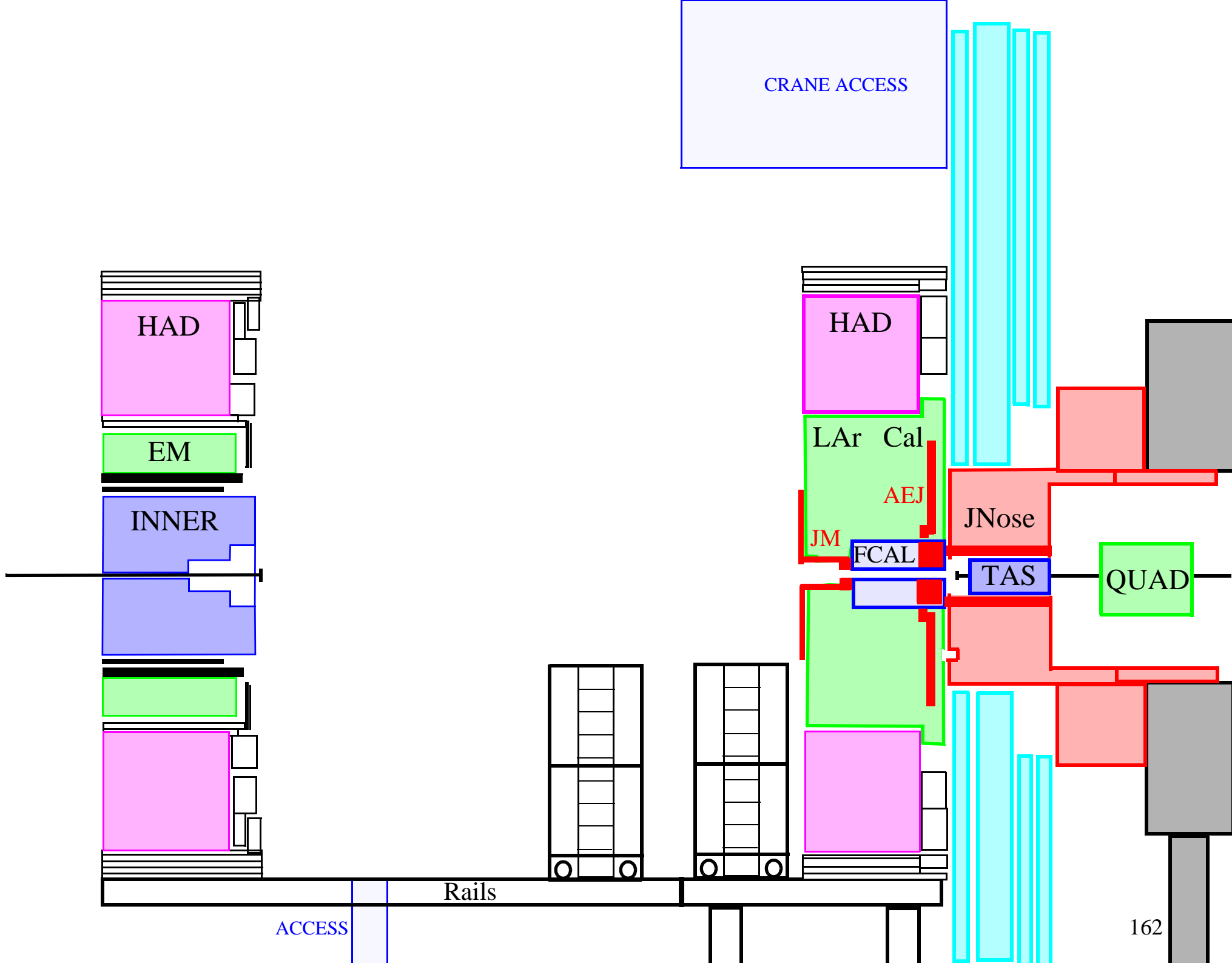

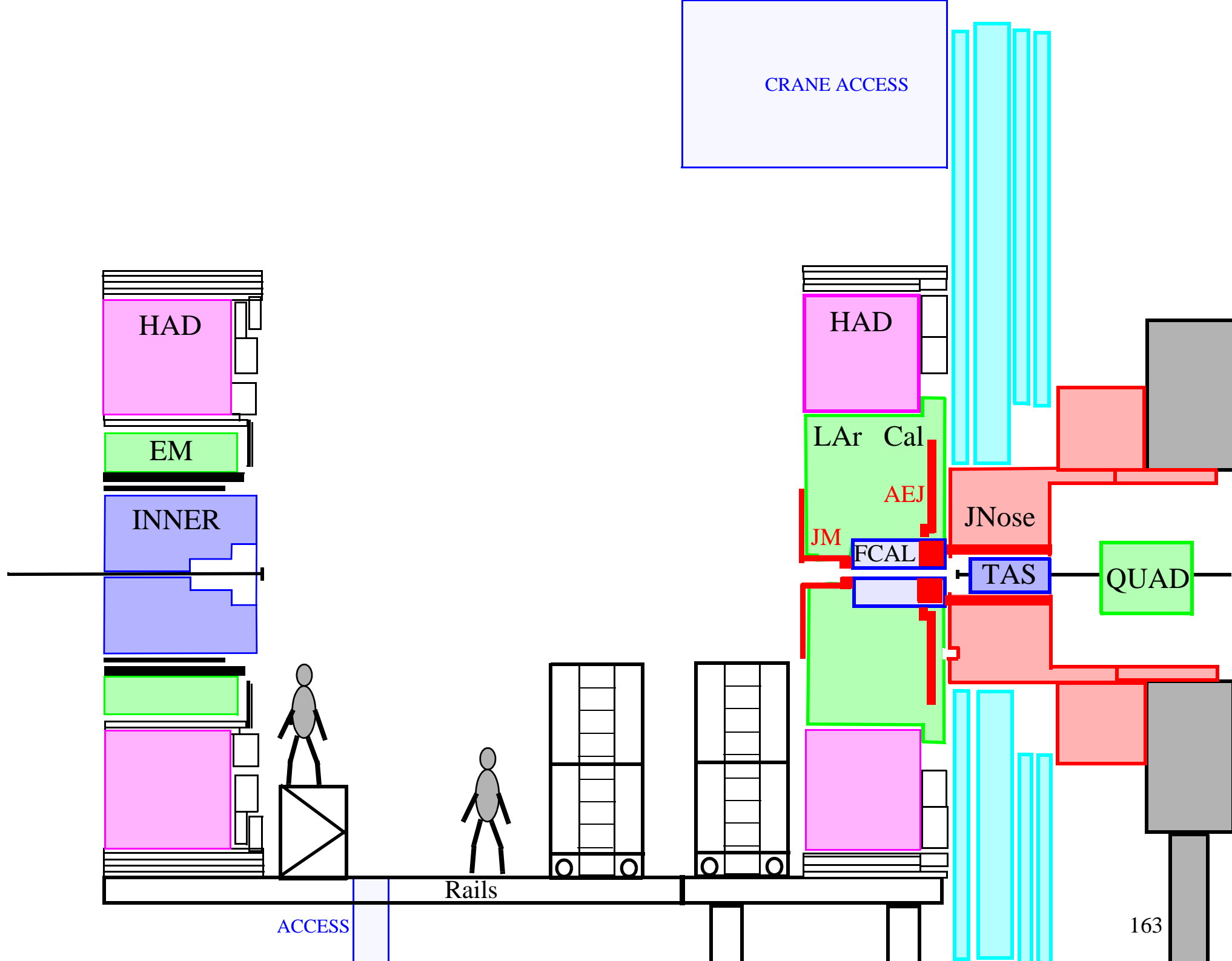

HAD

EM

INNER

HAD

HAD

LAr Cal

AEJ

JM

FCAL

JNose

TAS

QUAD

CRANE ACCESS

ACCESS

Rails

163

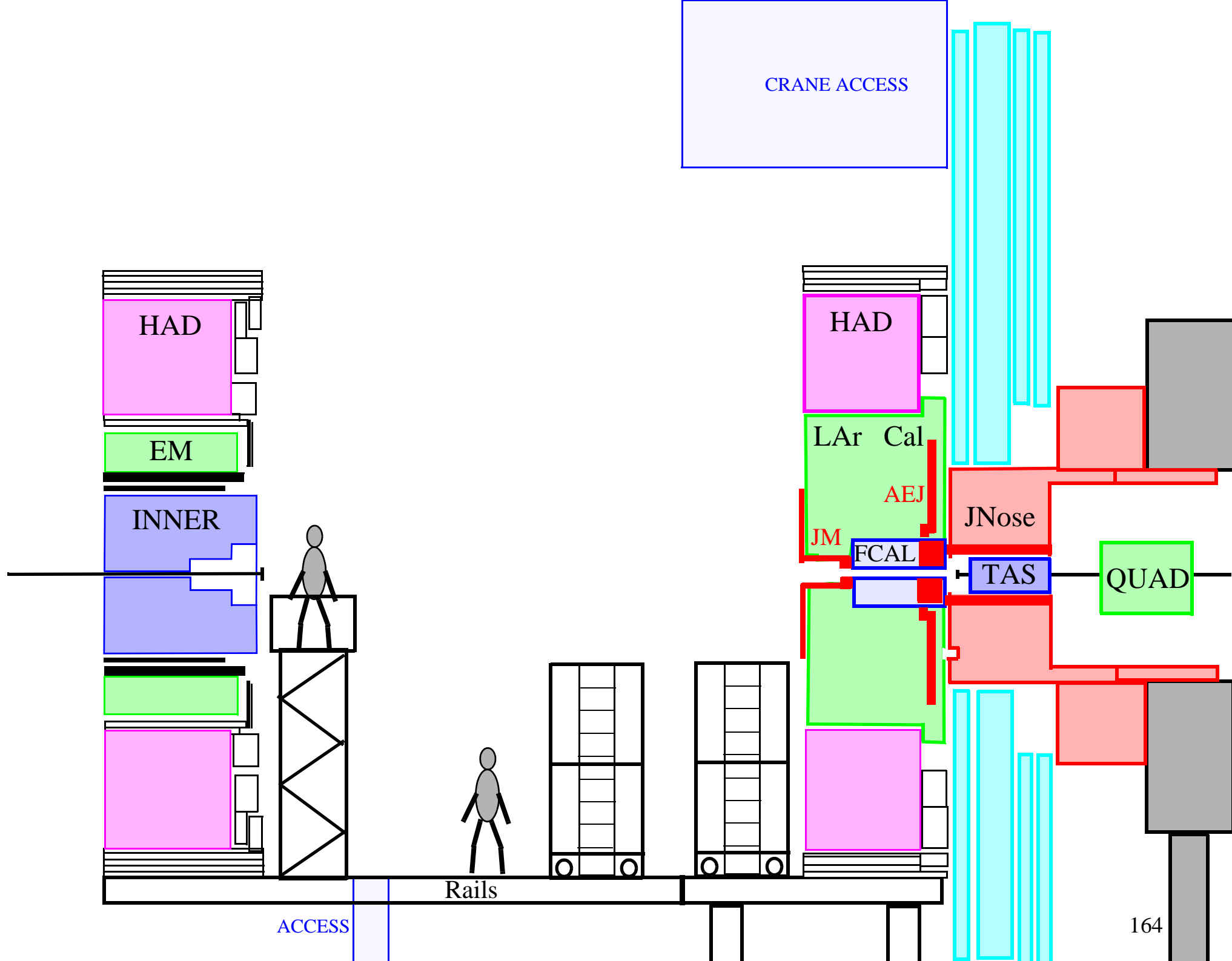

CRANE ACCESS

HAD

EM

INNER

HAD

LAr Cal

AEJ

JM

FCAL

JNose

TAS

QUAD

Rails

ACCESS

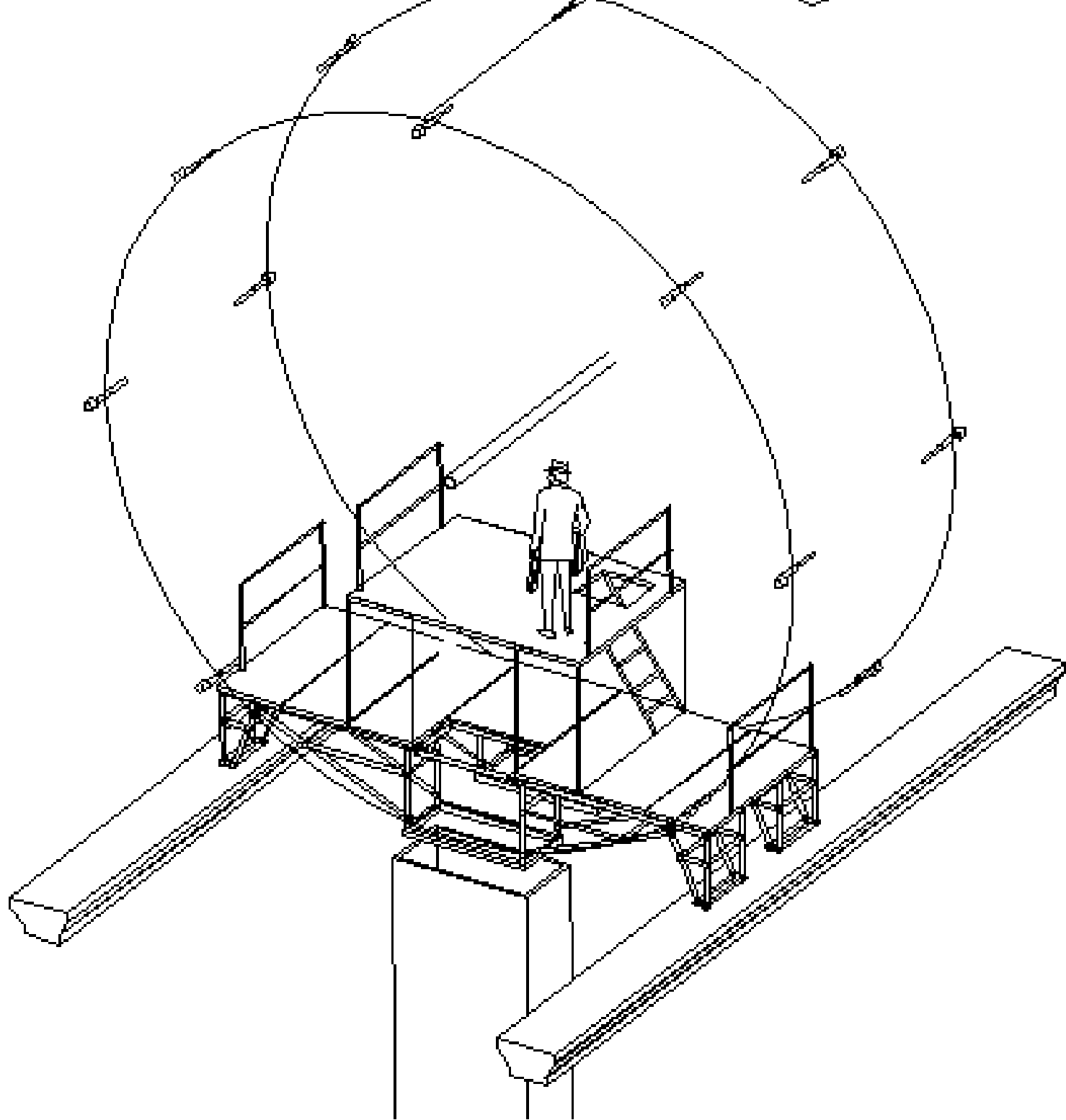

April 2007

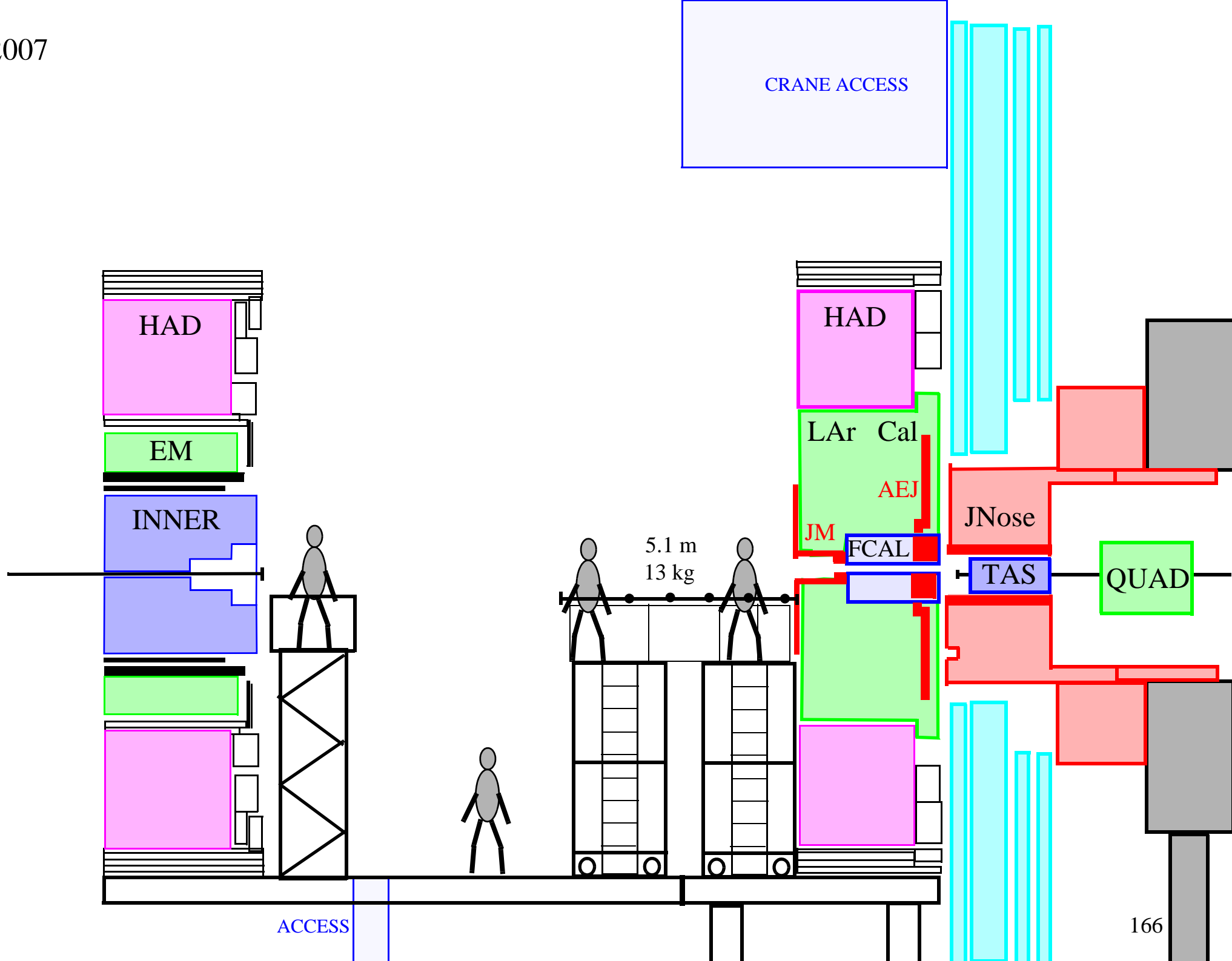

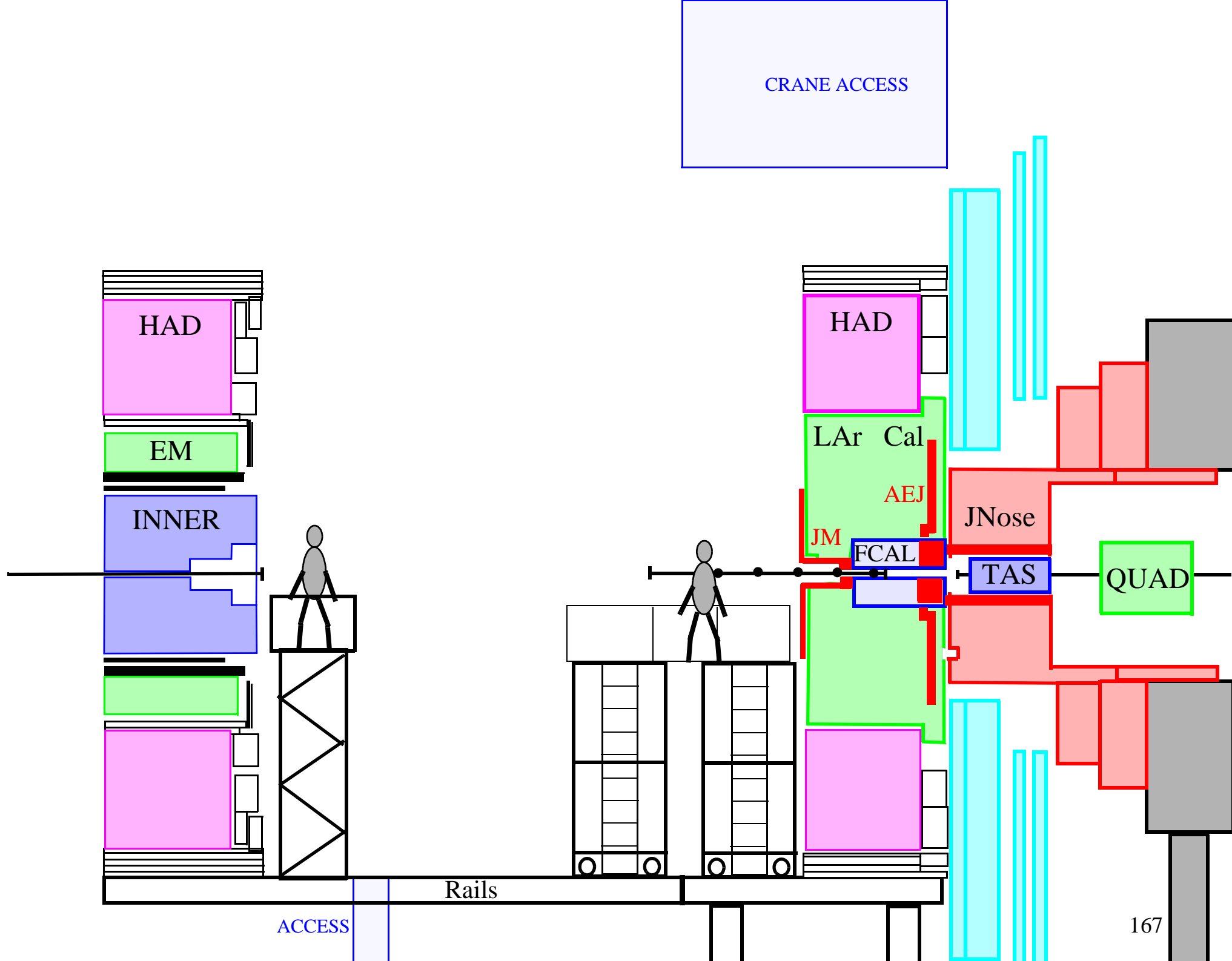

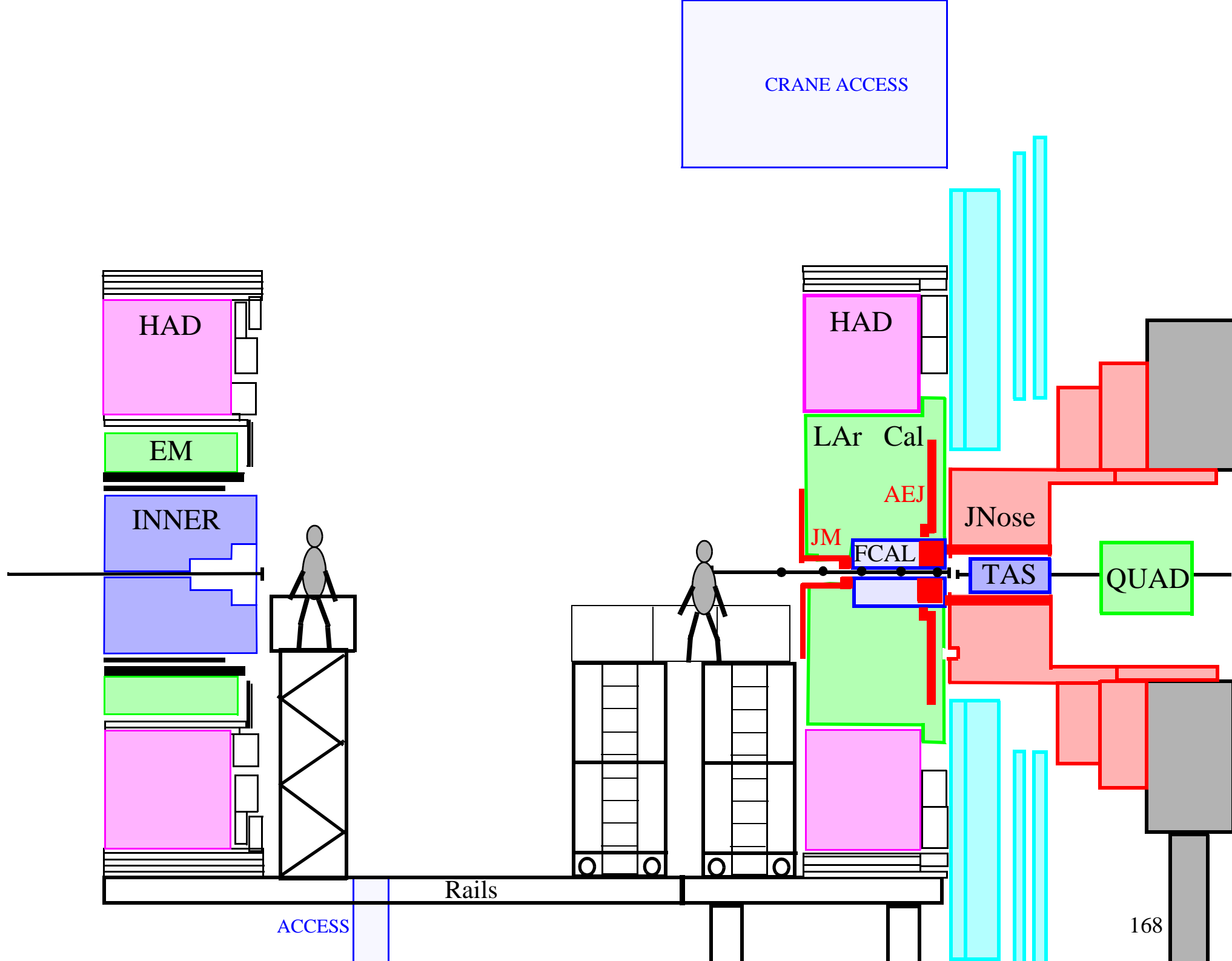

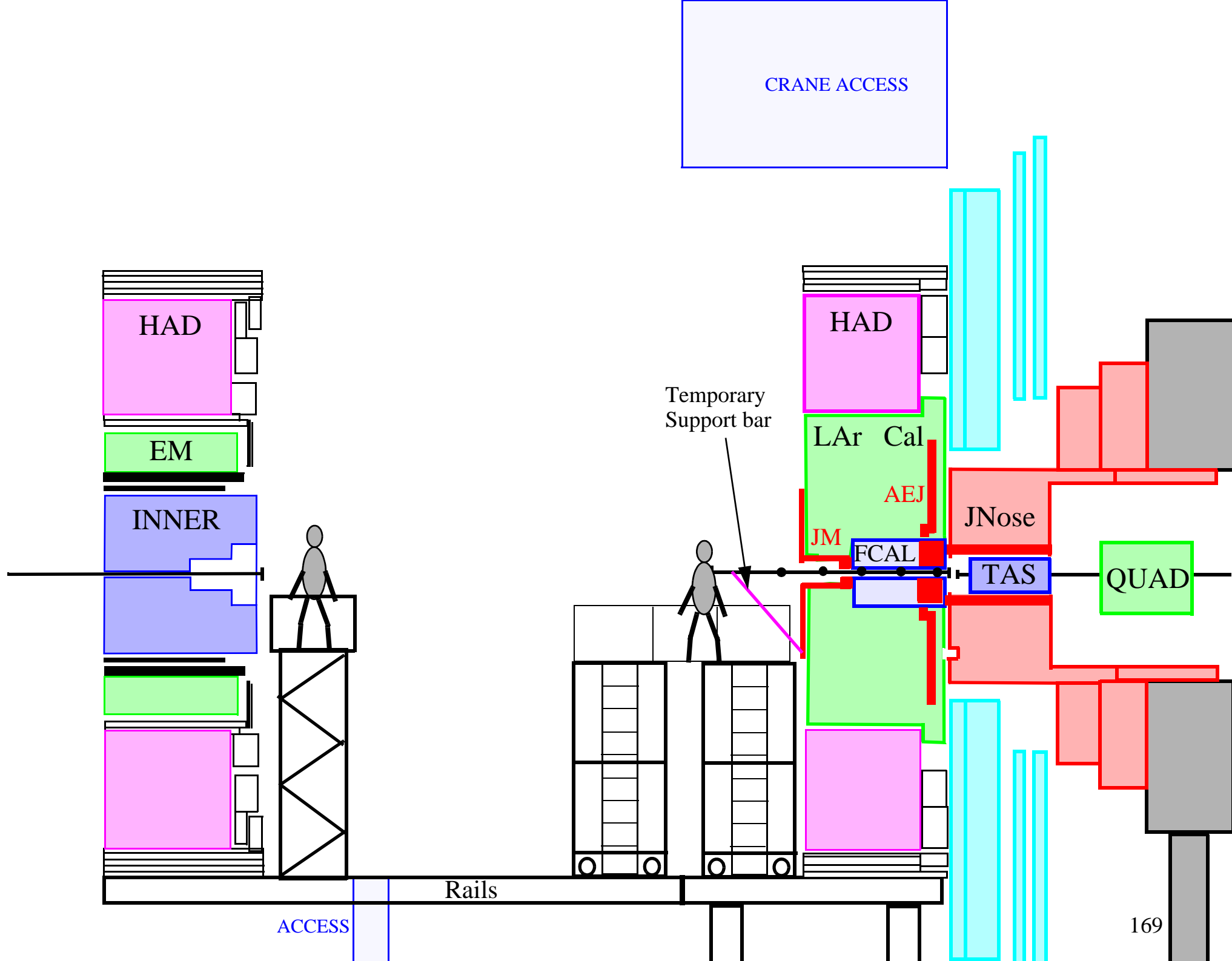

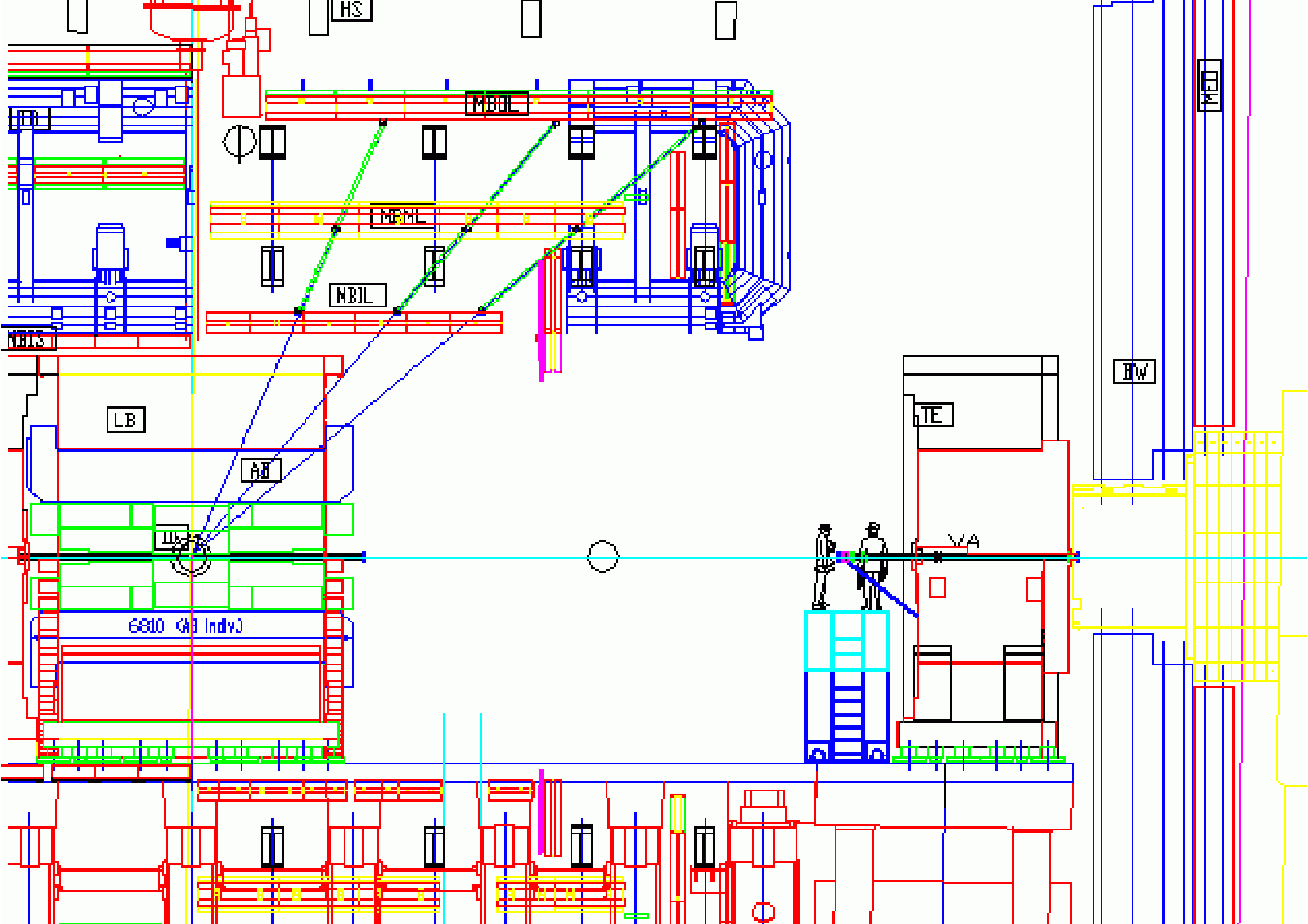

HS

MBUL

NBI

NBI

NBI

LB

AB

LU

6810 (AB Indv)

TE

VA

HW

MEL

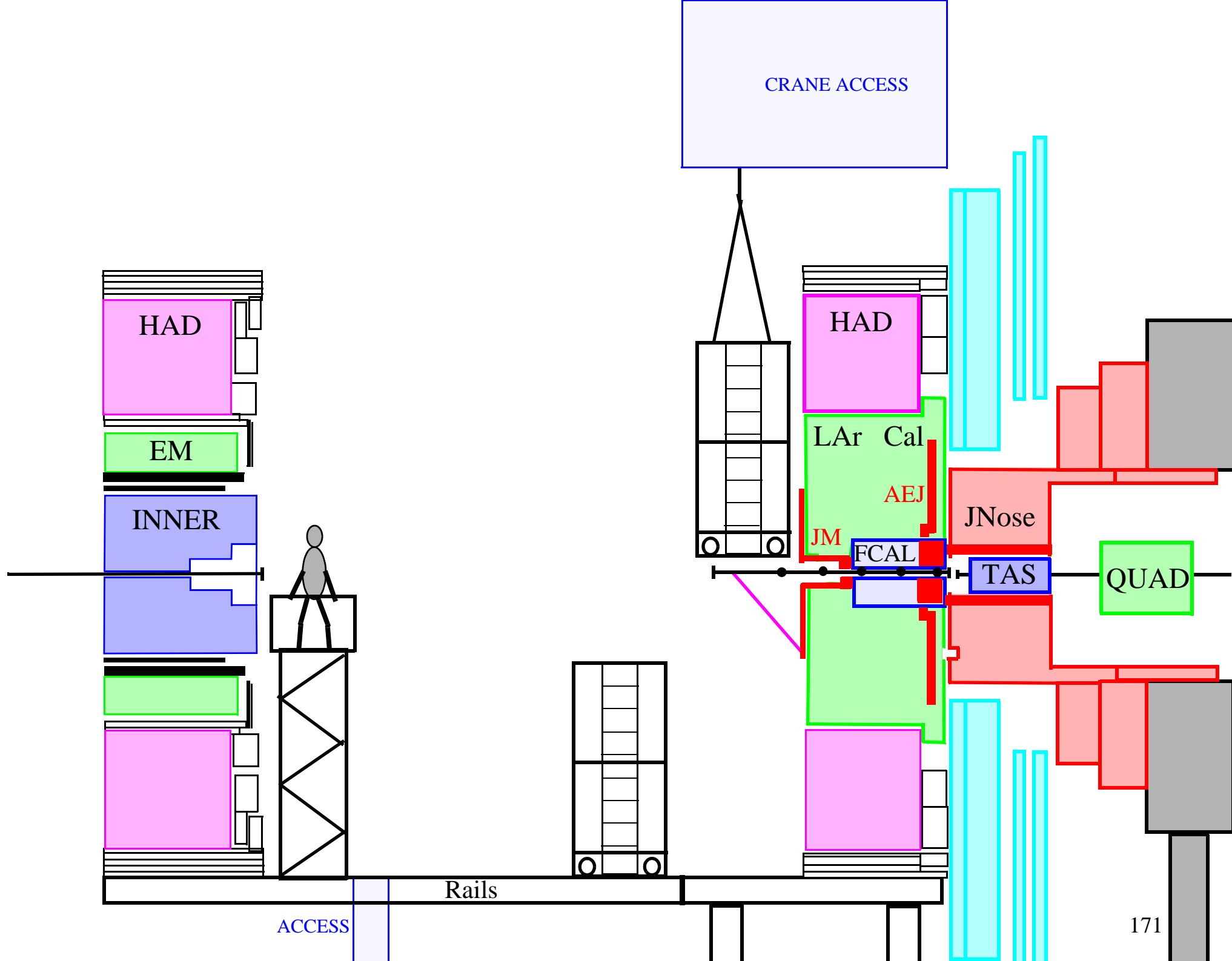

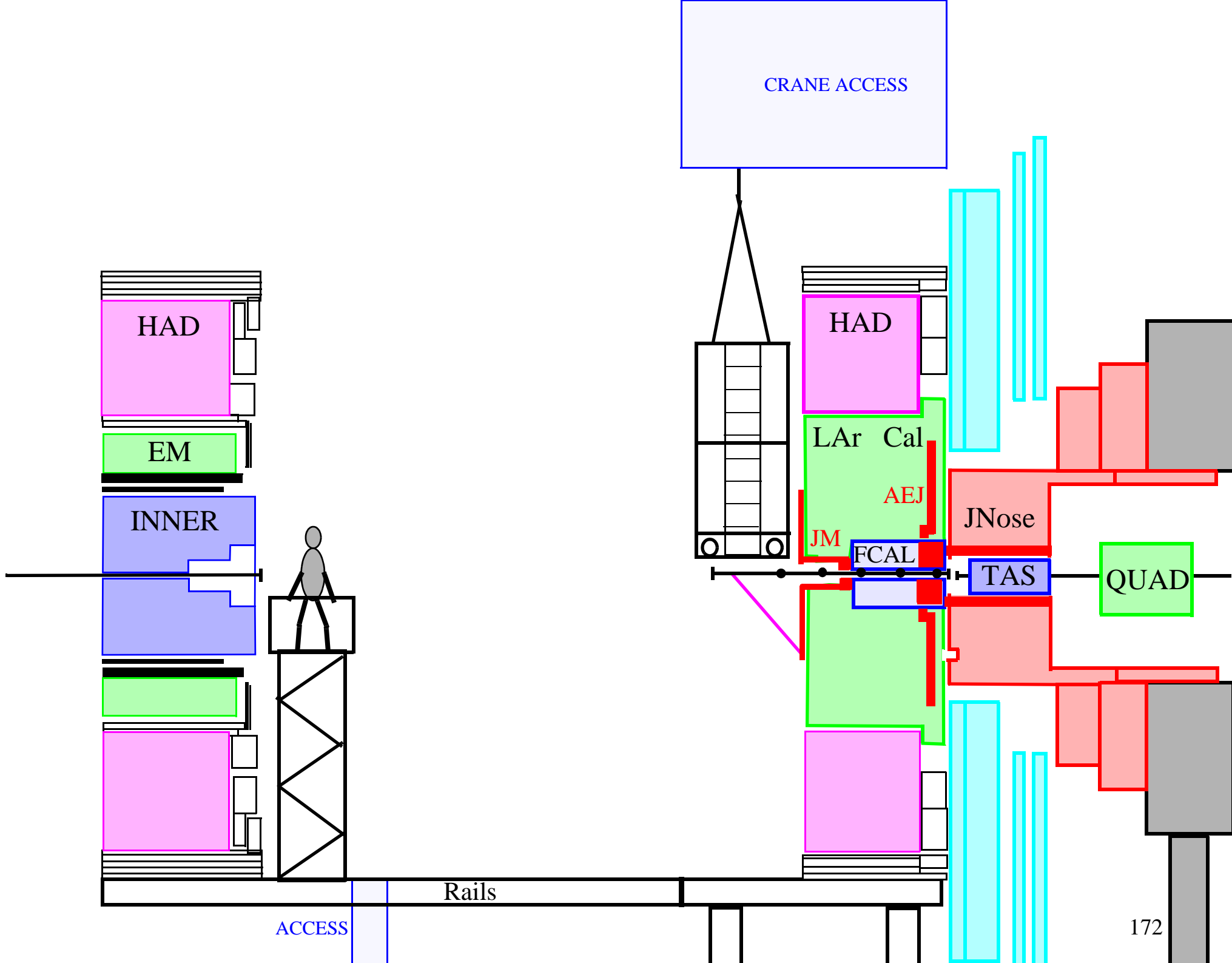

CRANE ACCESS

HAD

EM

INNER

HAD

LAr Cal

AEJ

JM

FCAL

JNose

TAS

QUAD

Rails

ACCESS

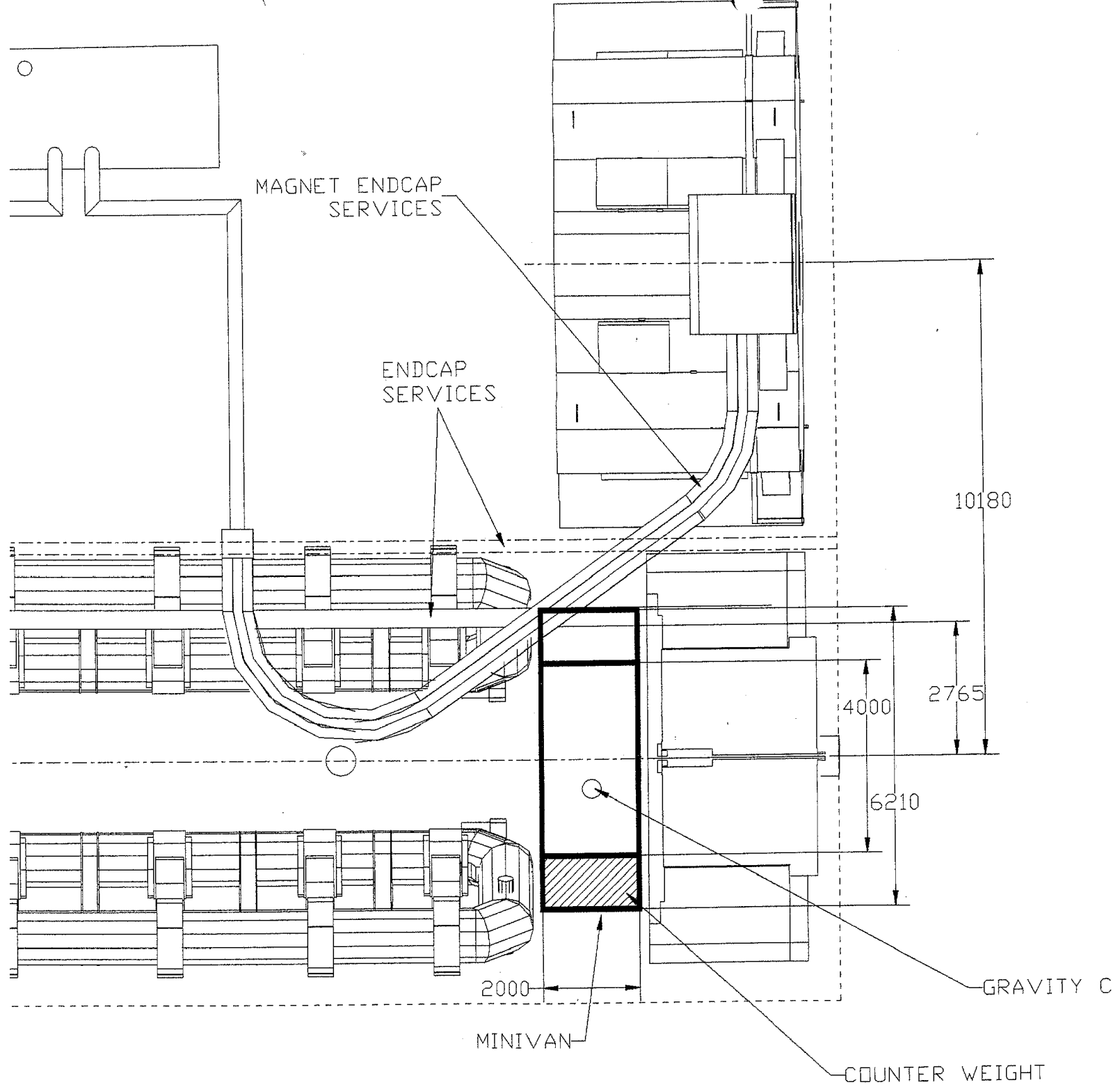

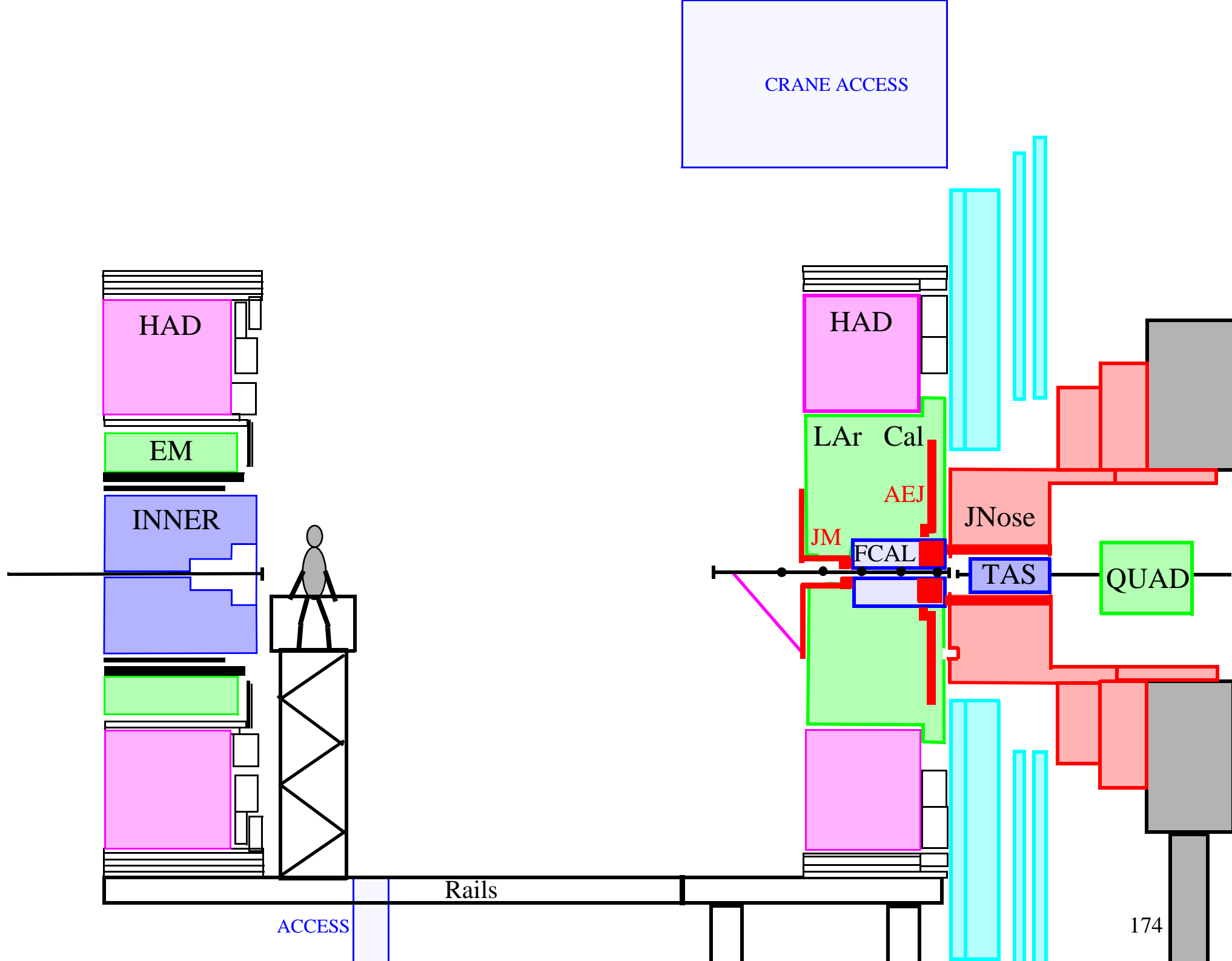

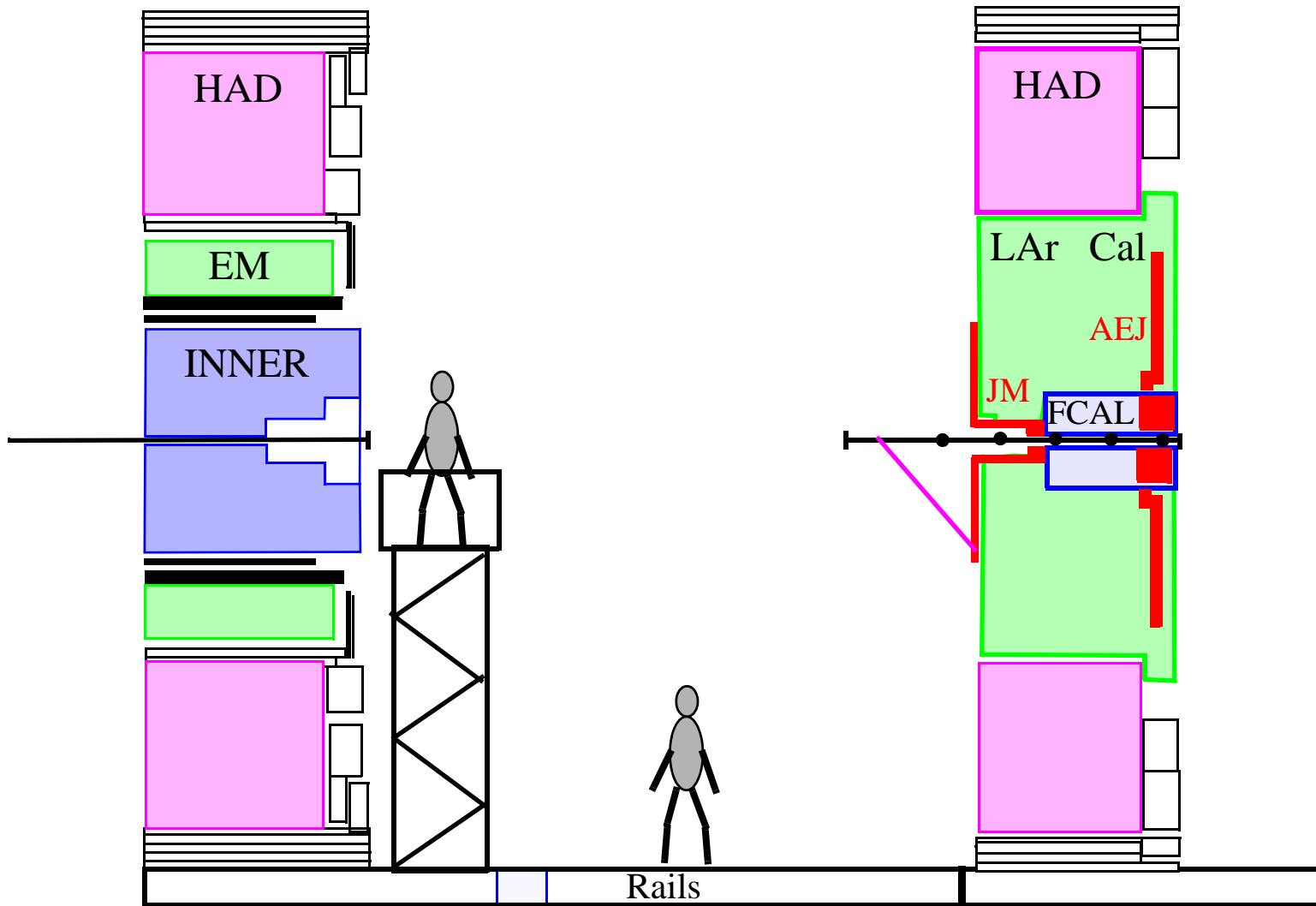

ACCESS

Rails

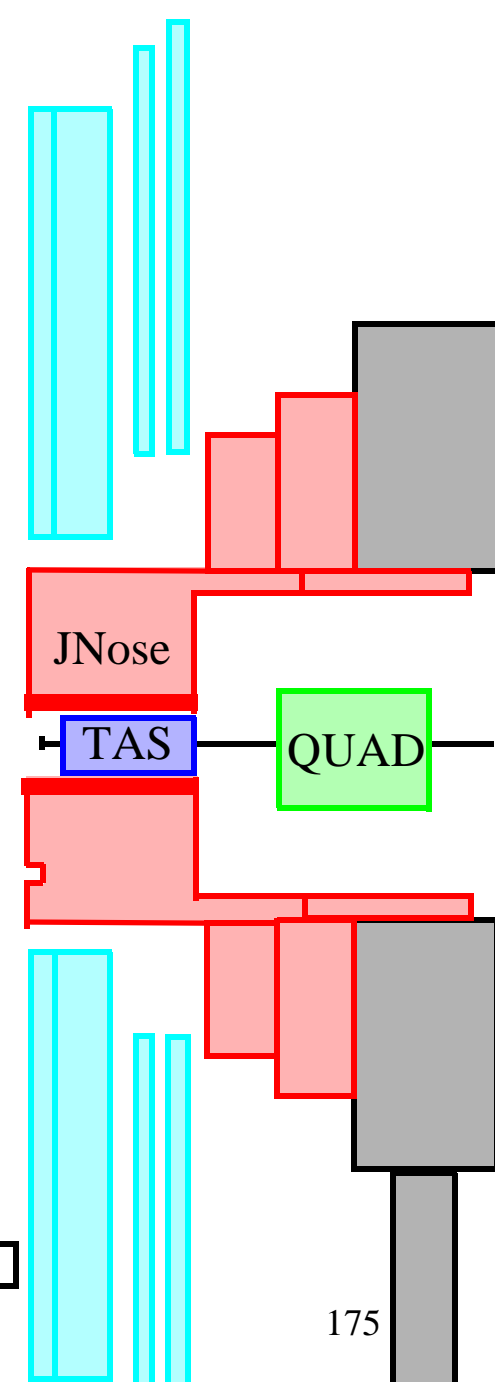

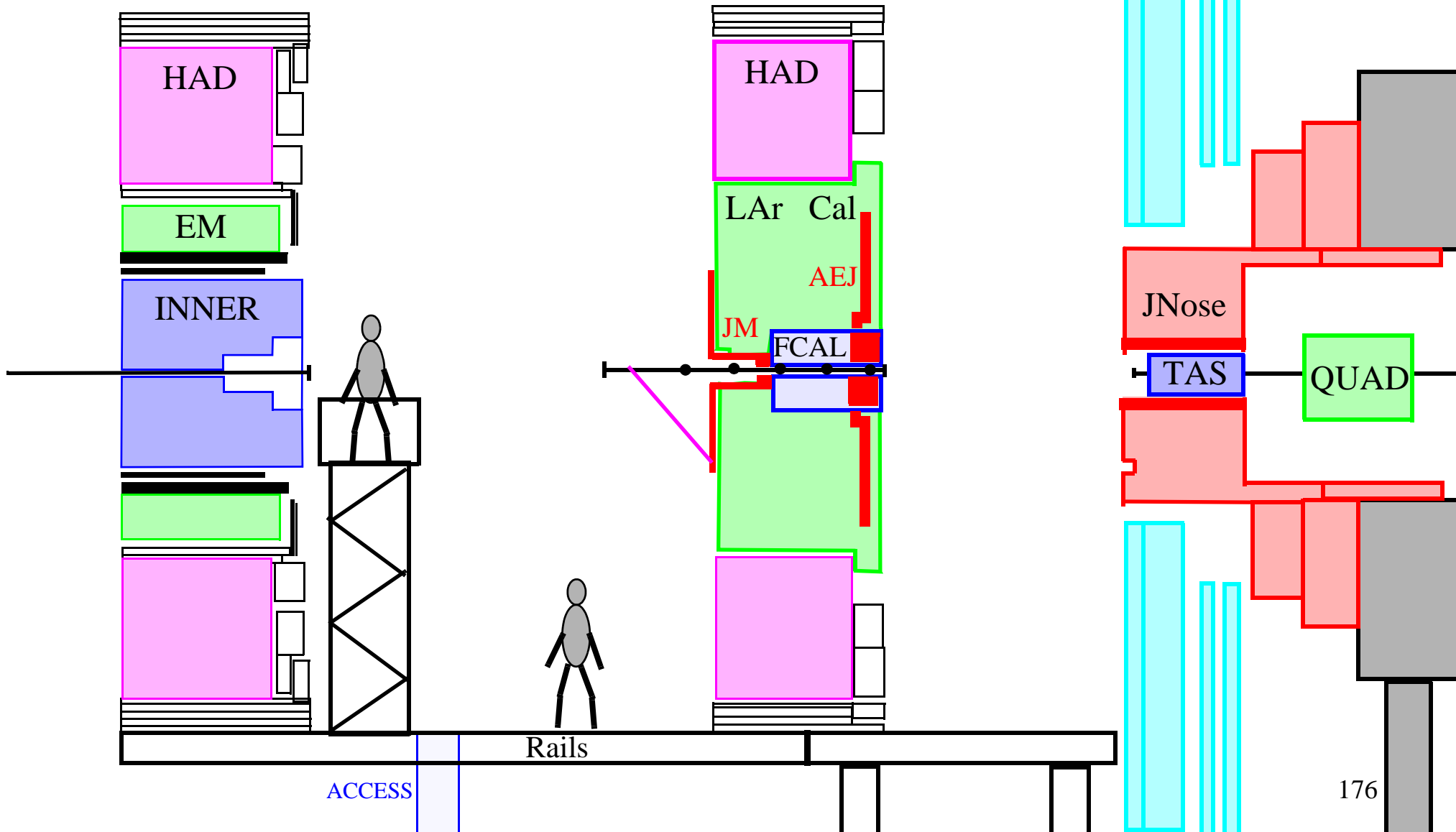

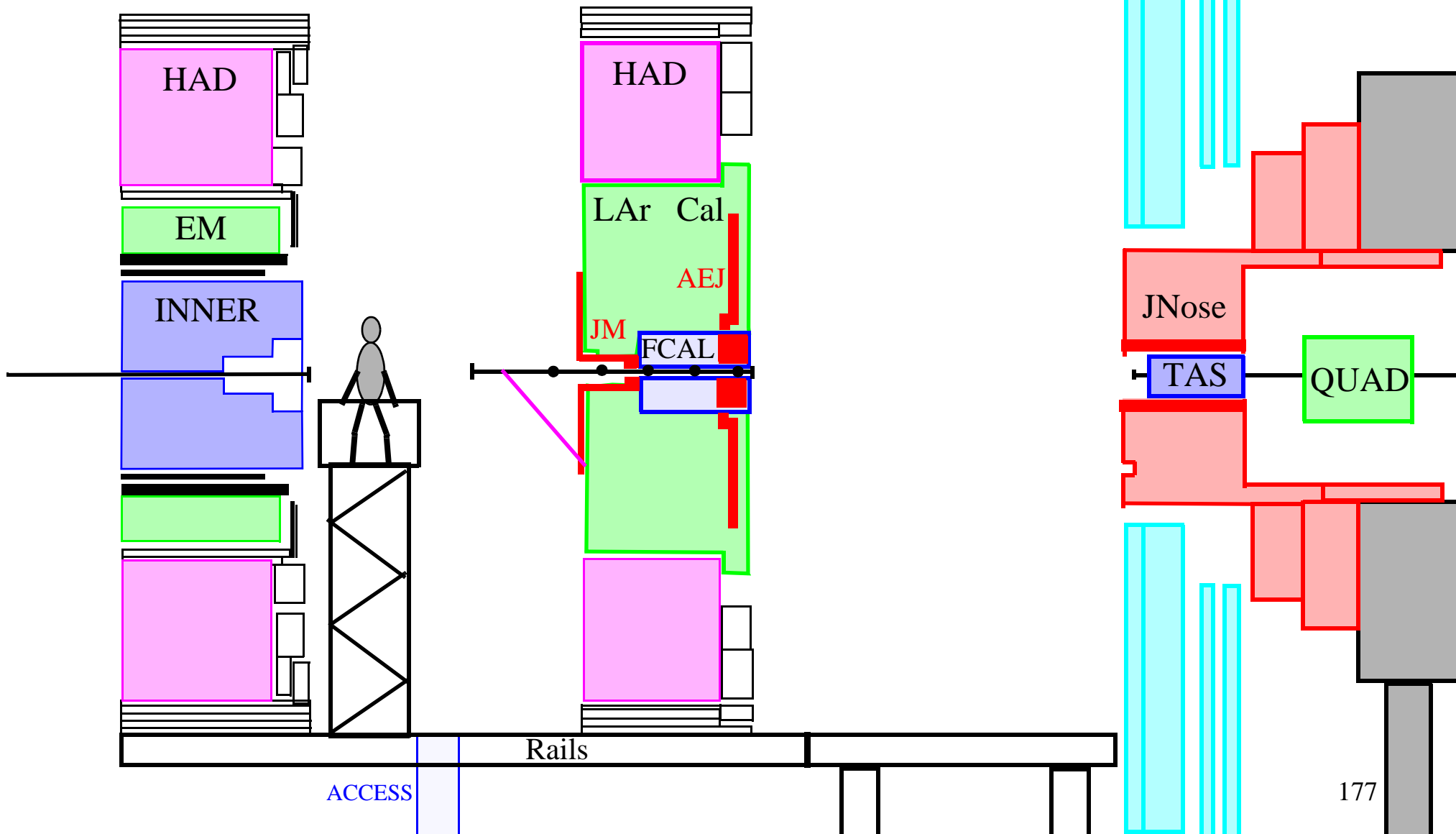

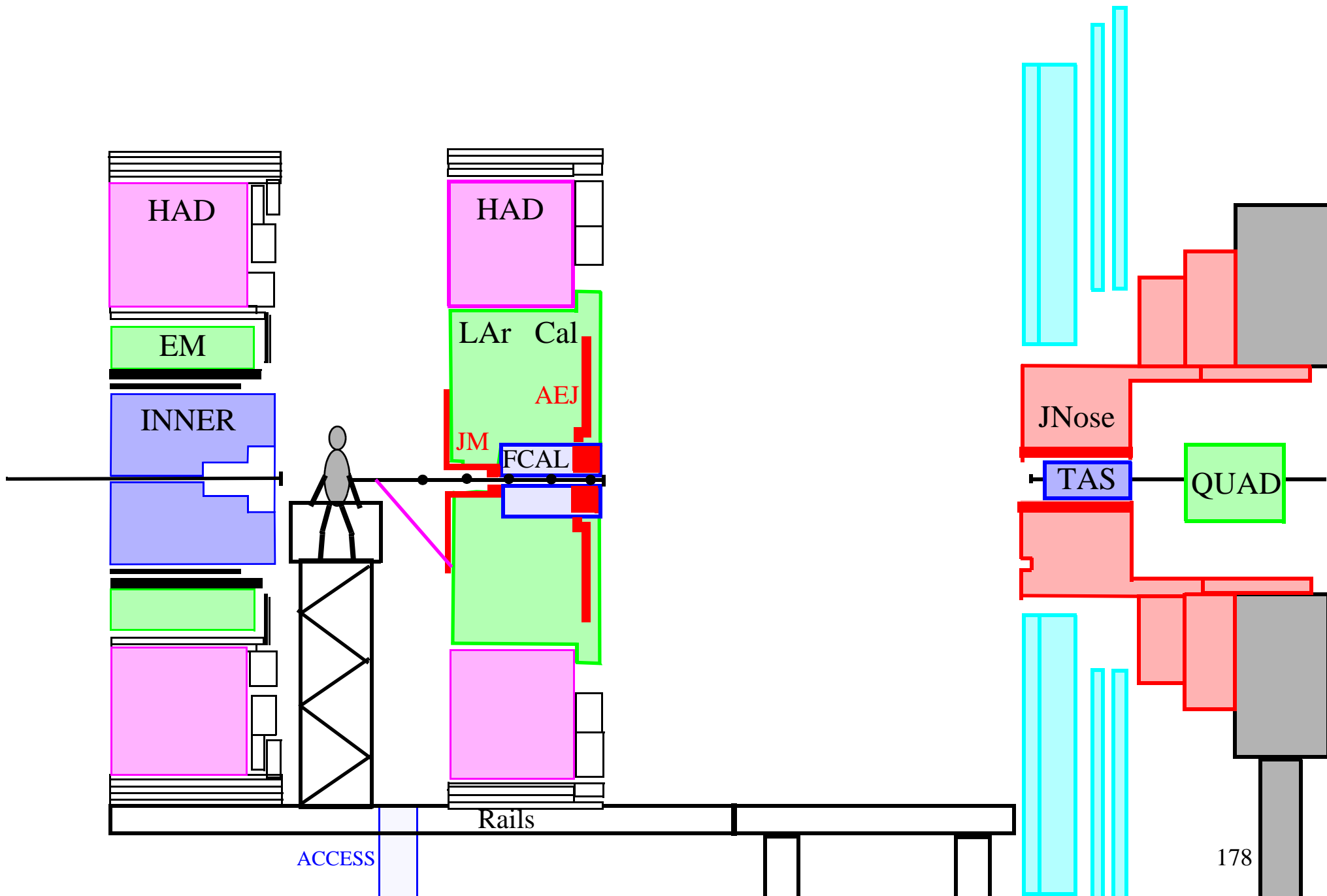

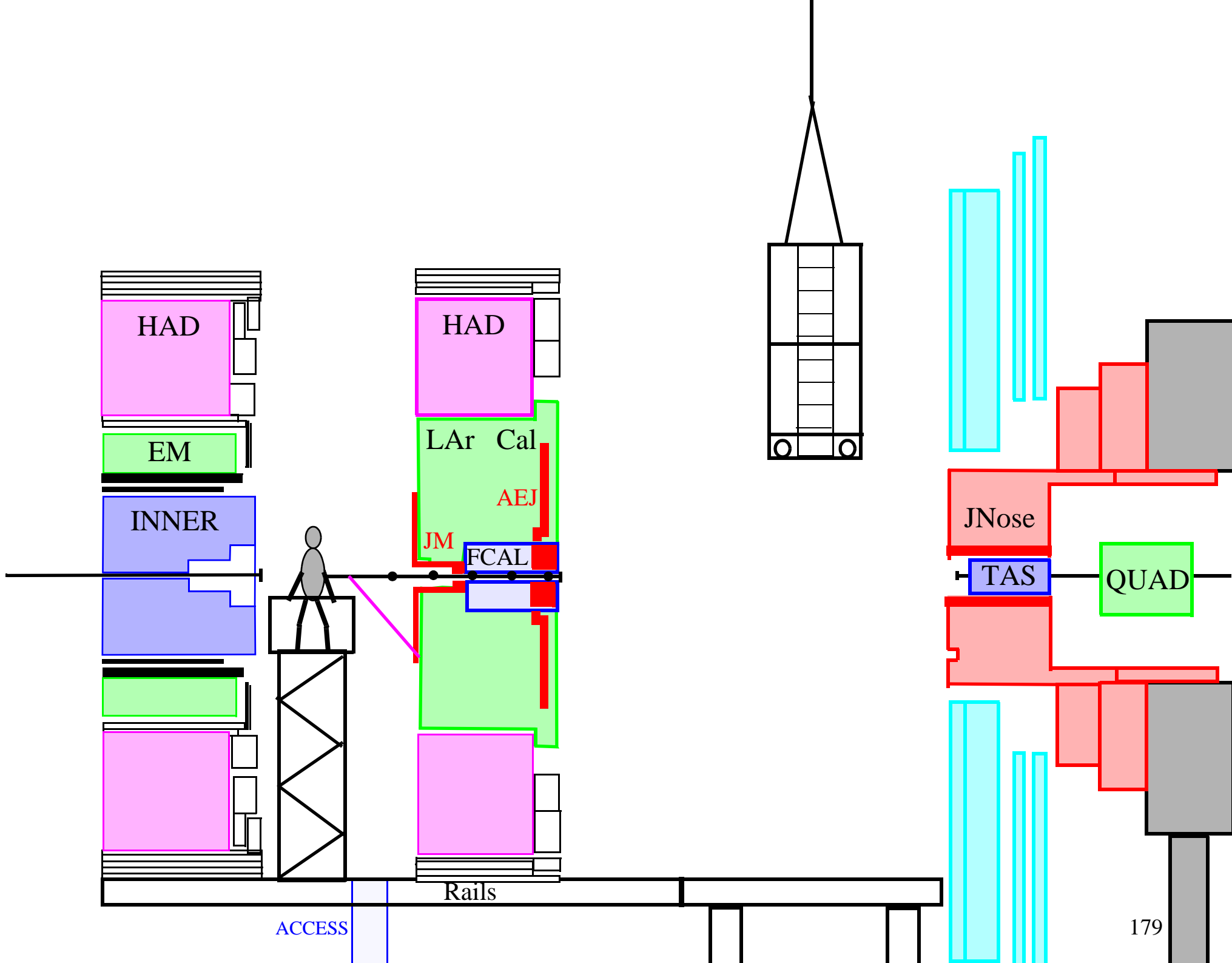

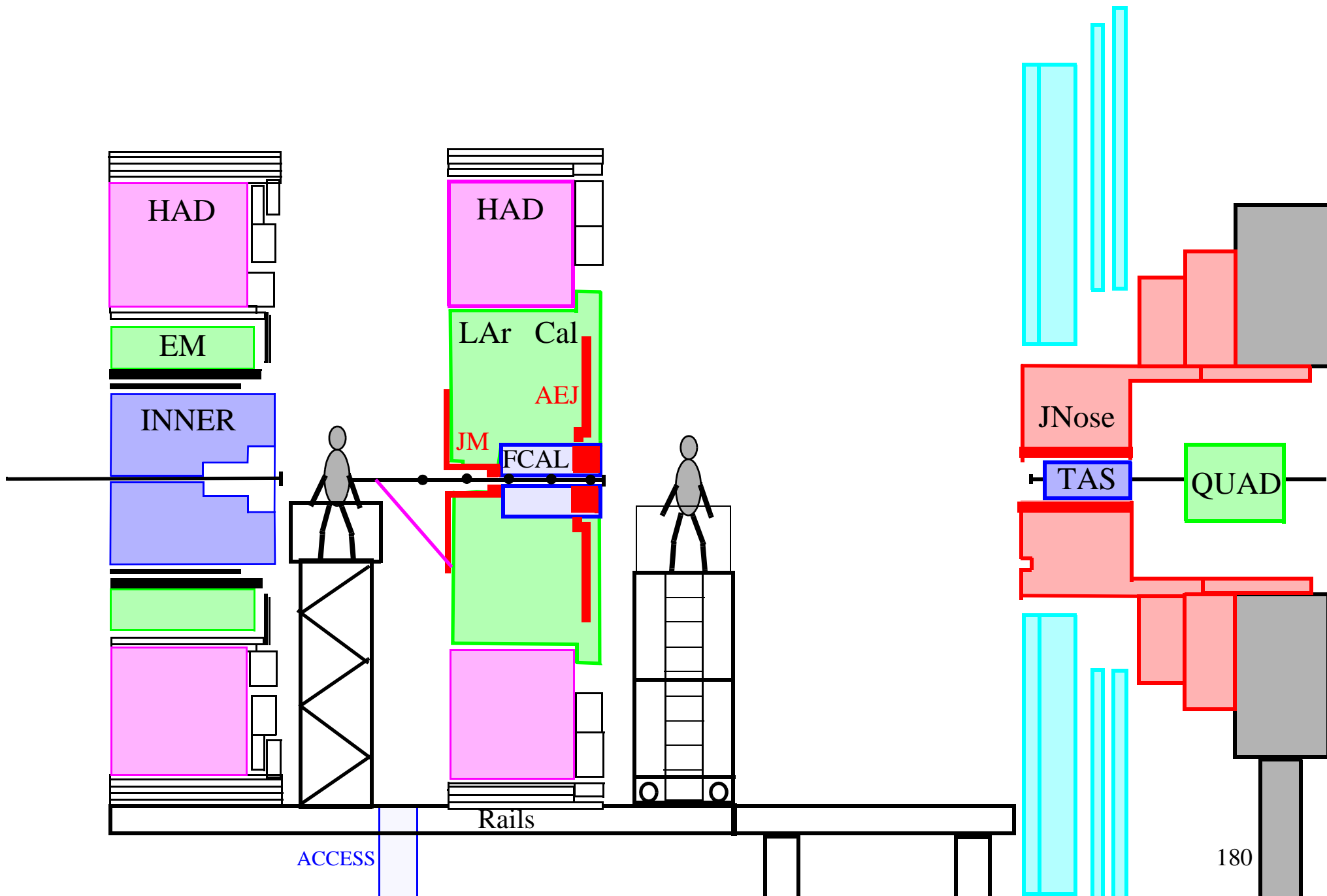

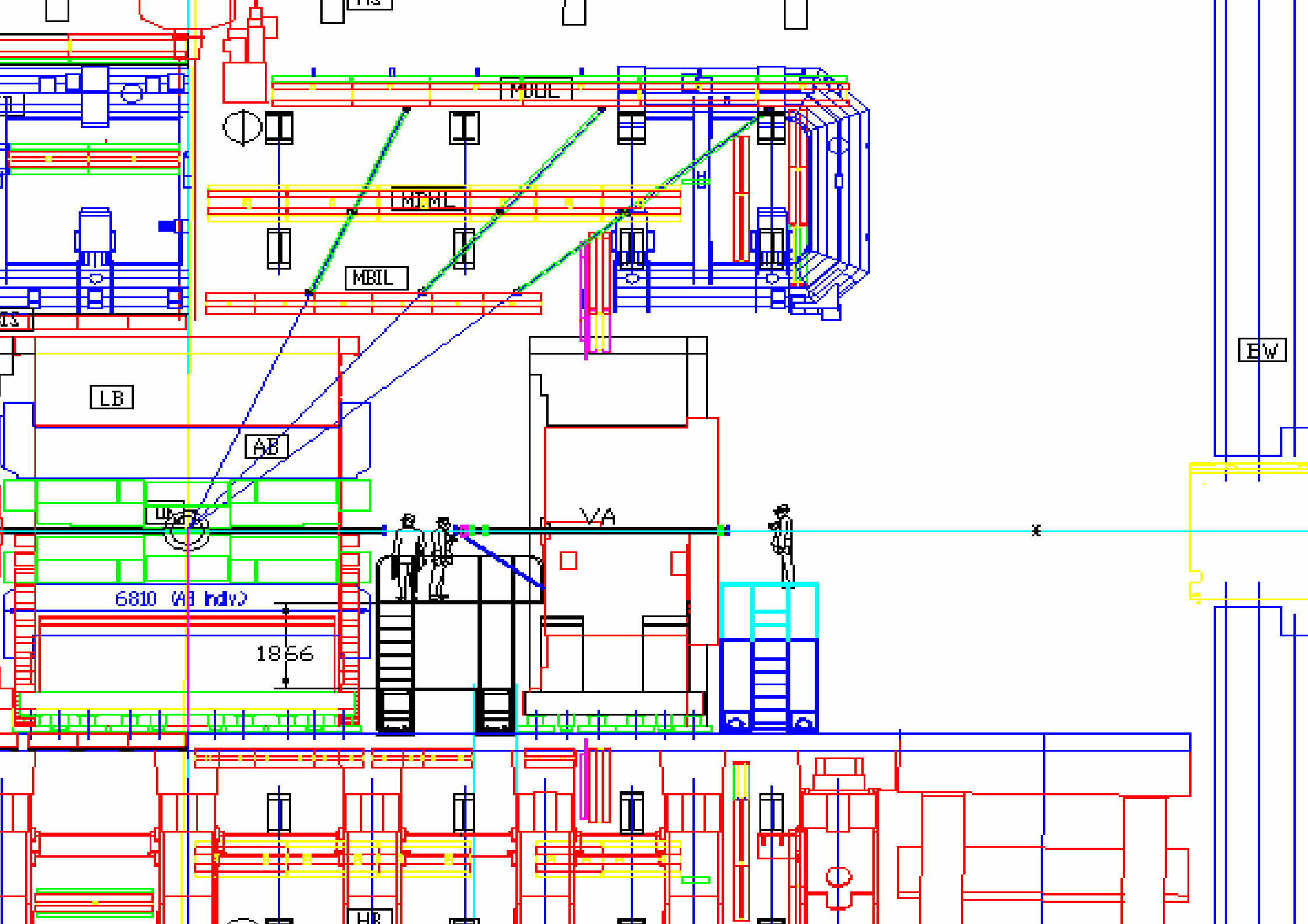

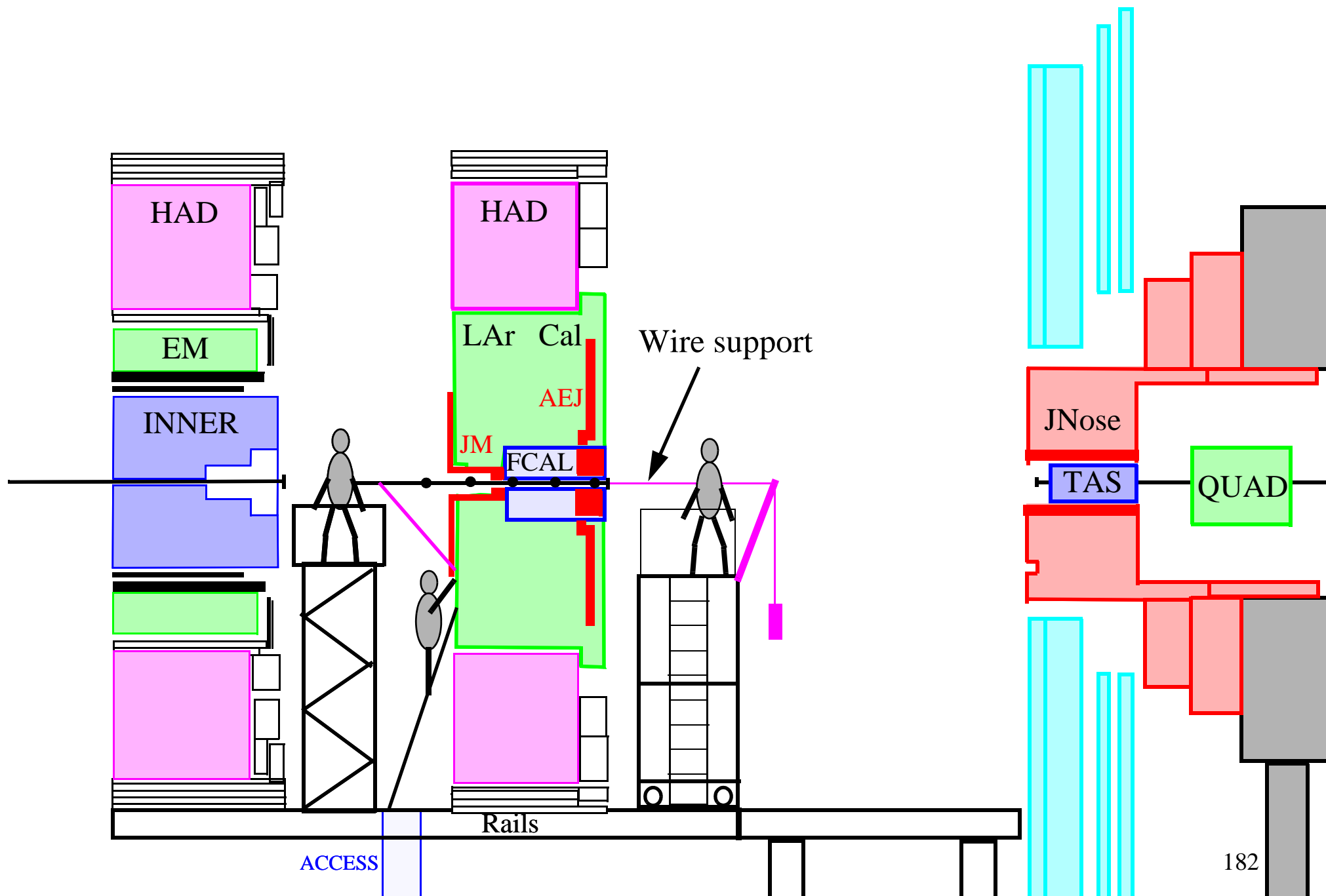

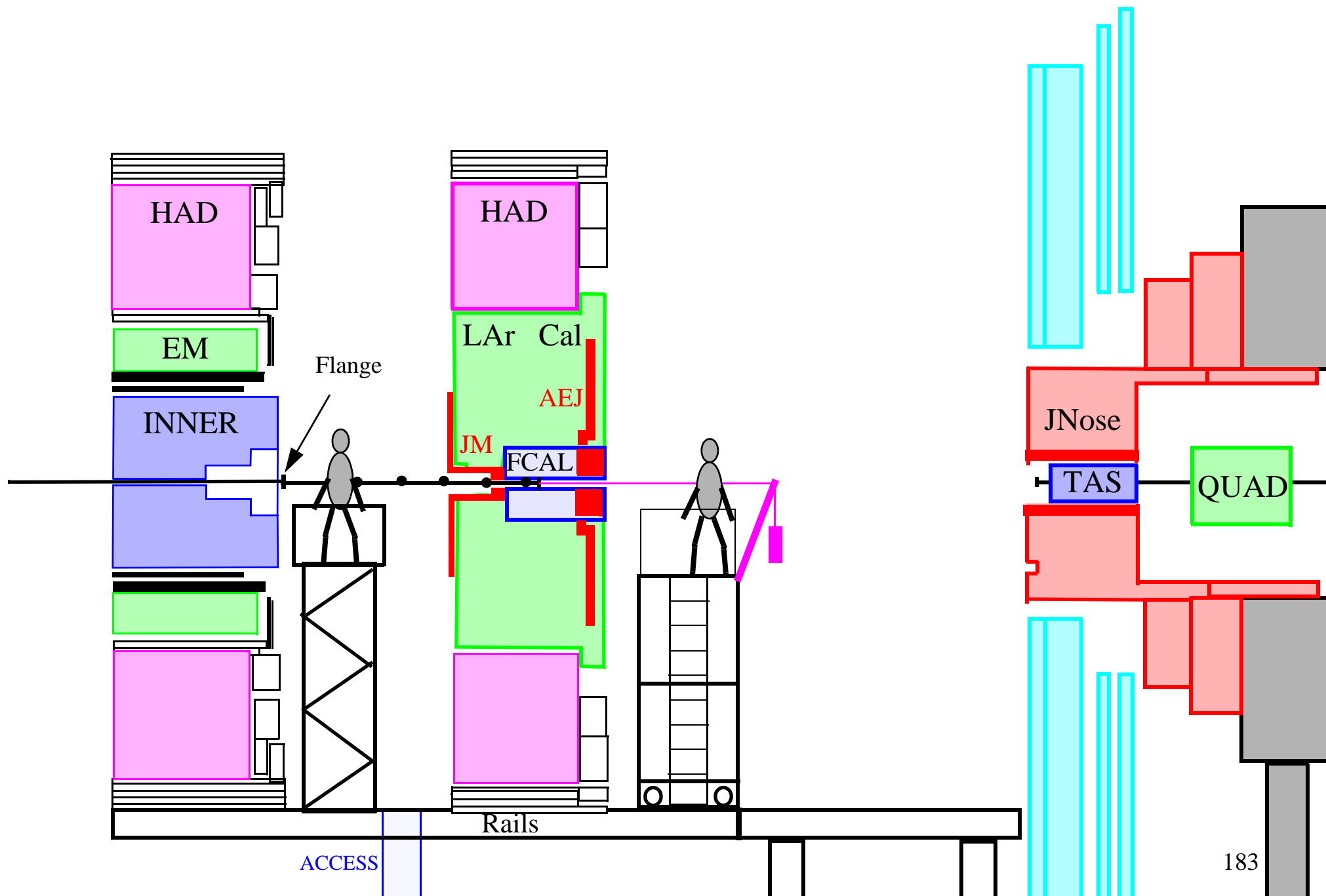

ACCESS

Rails

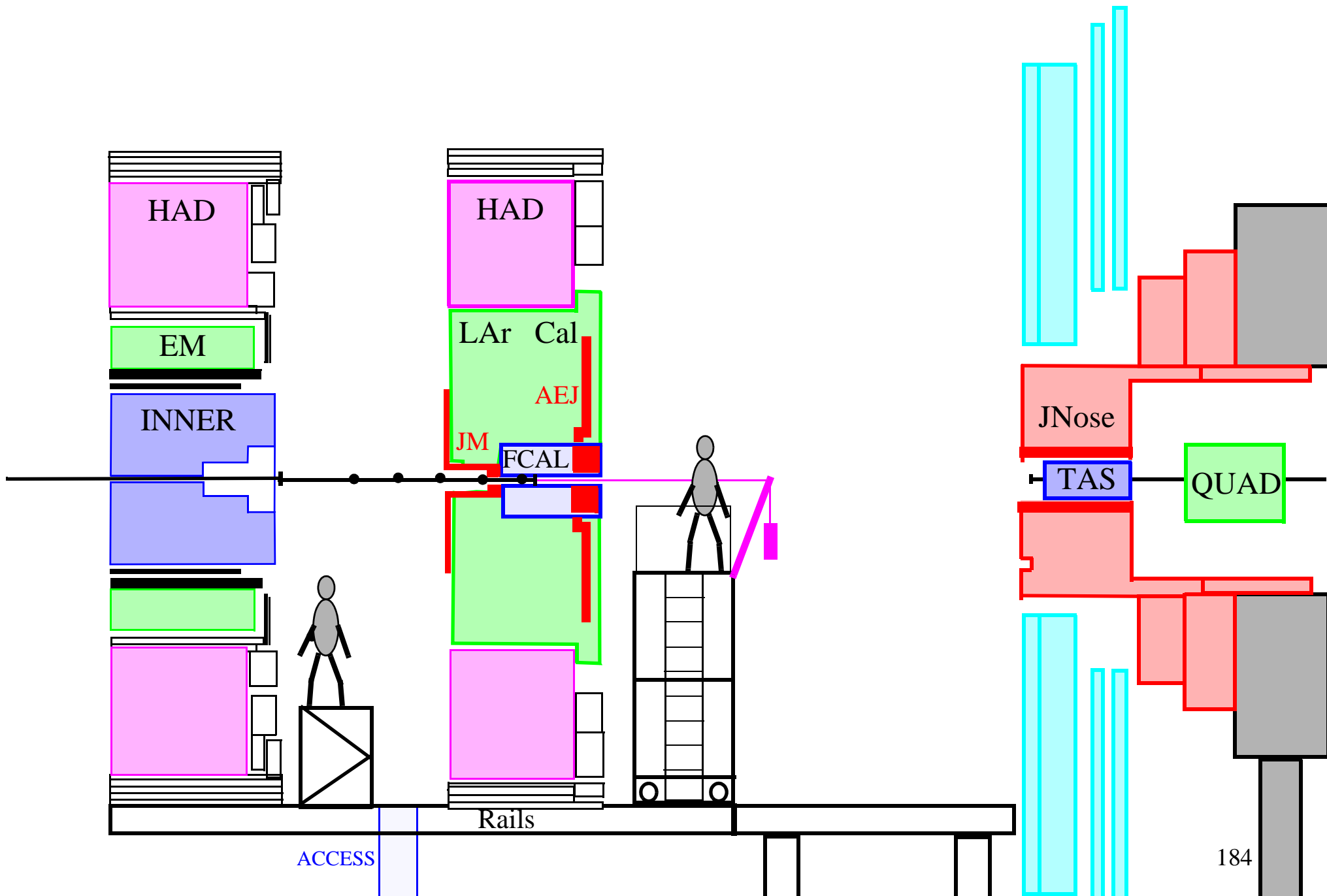

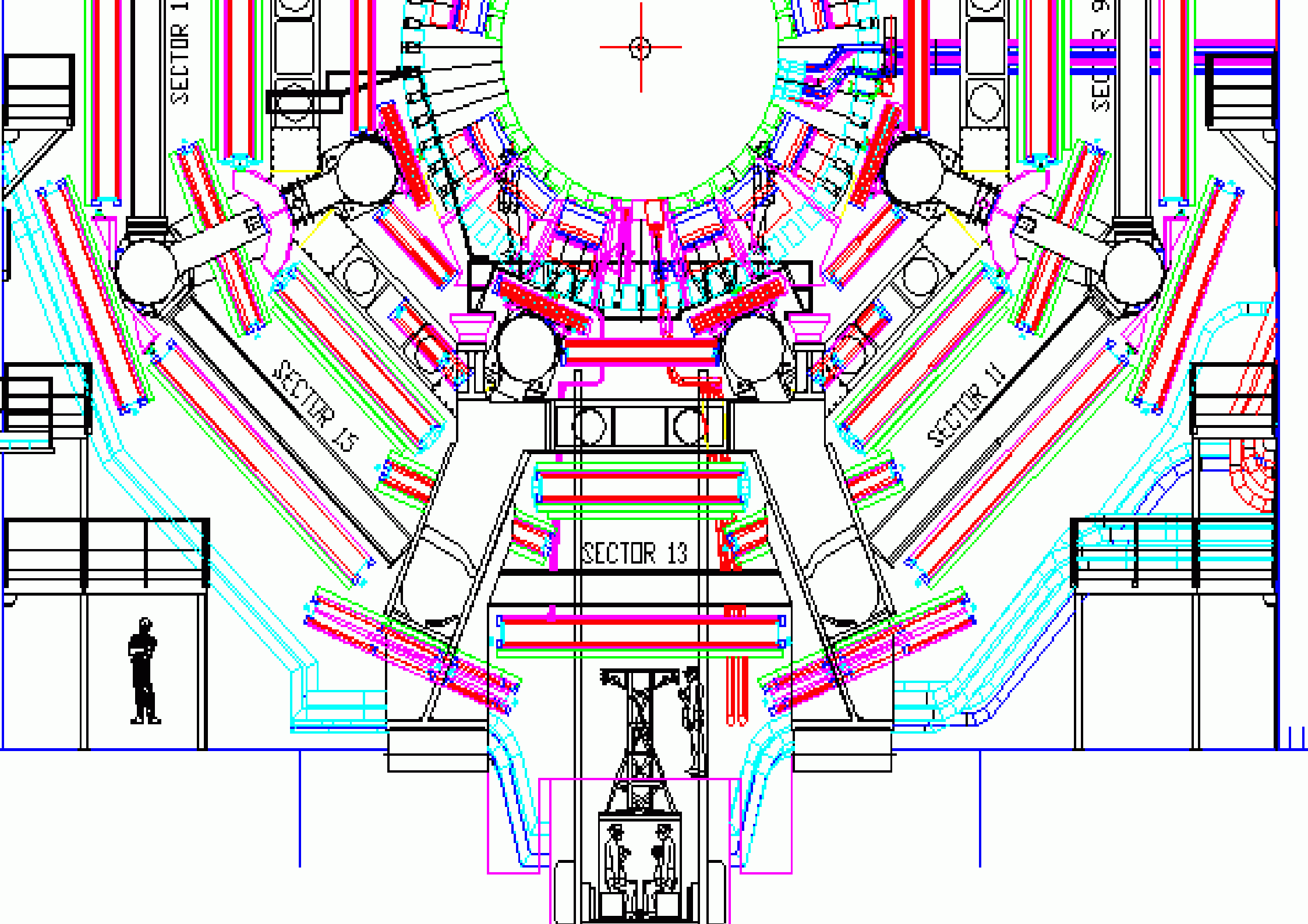

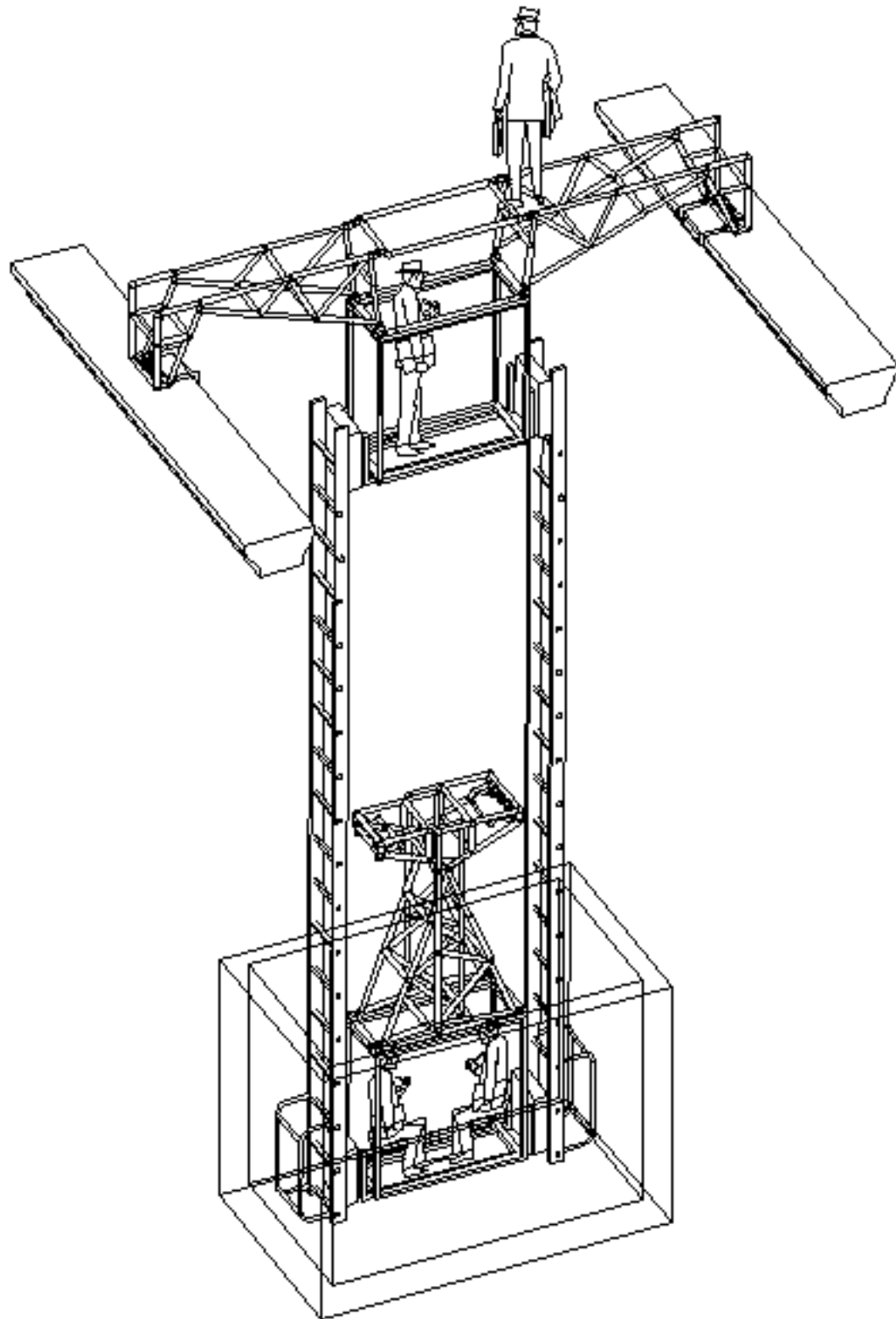

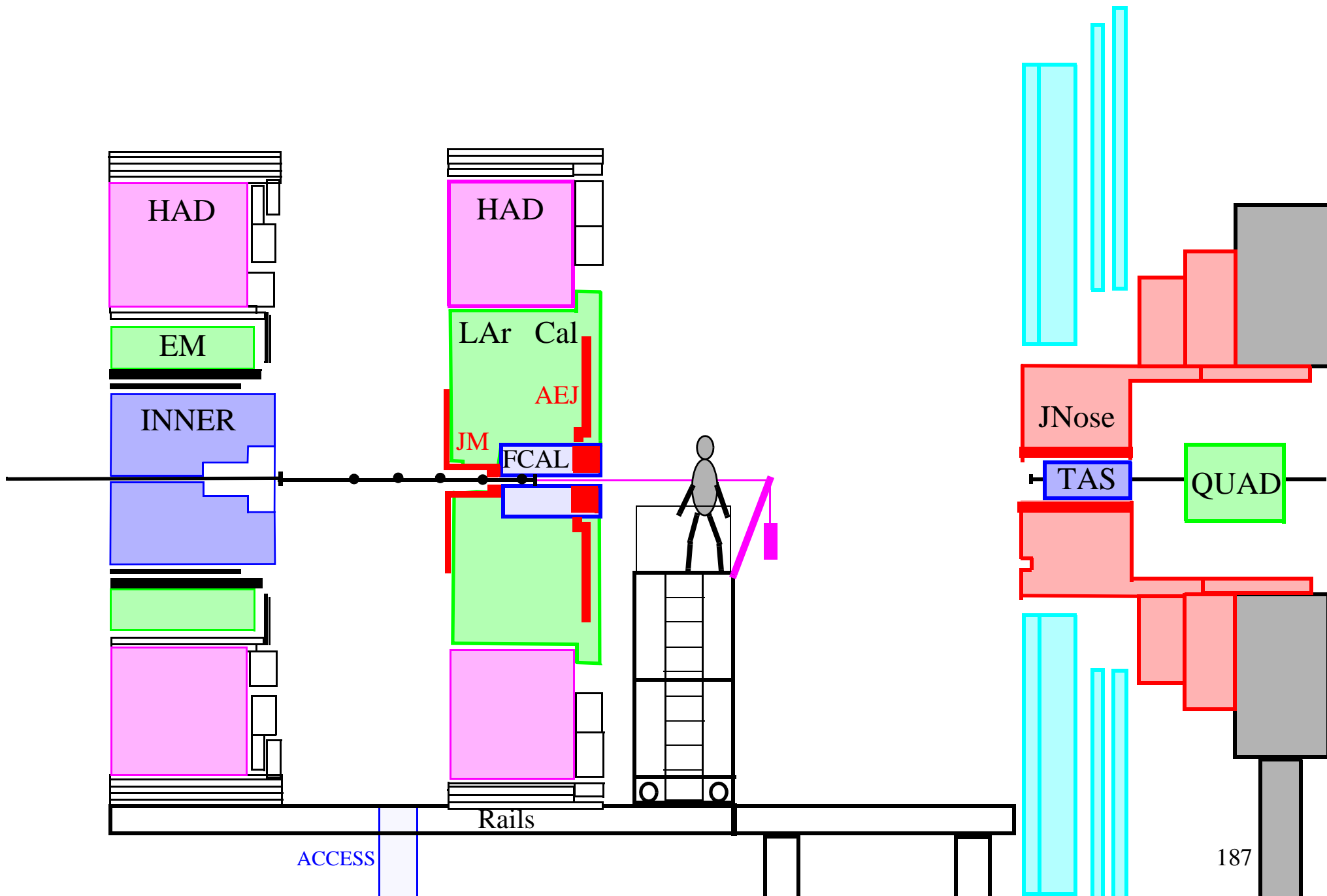

ACCESS

RAILS

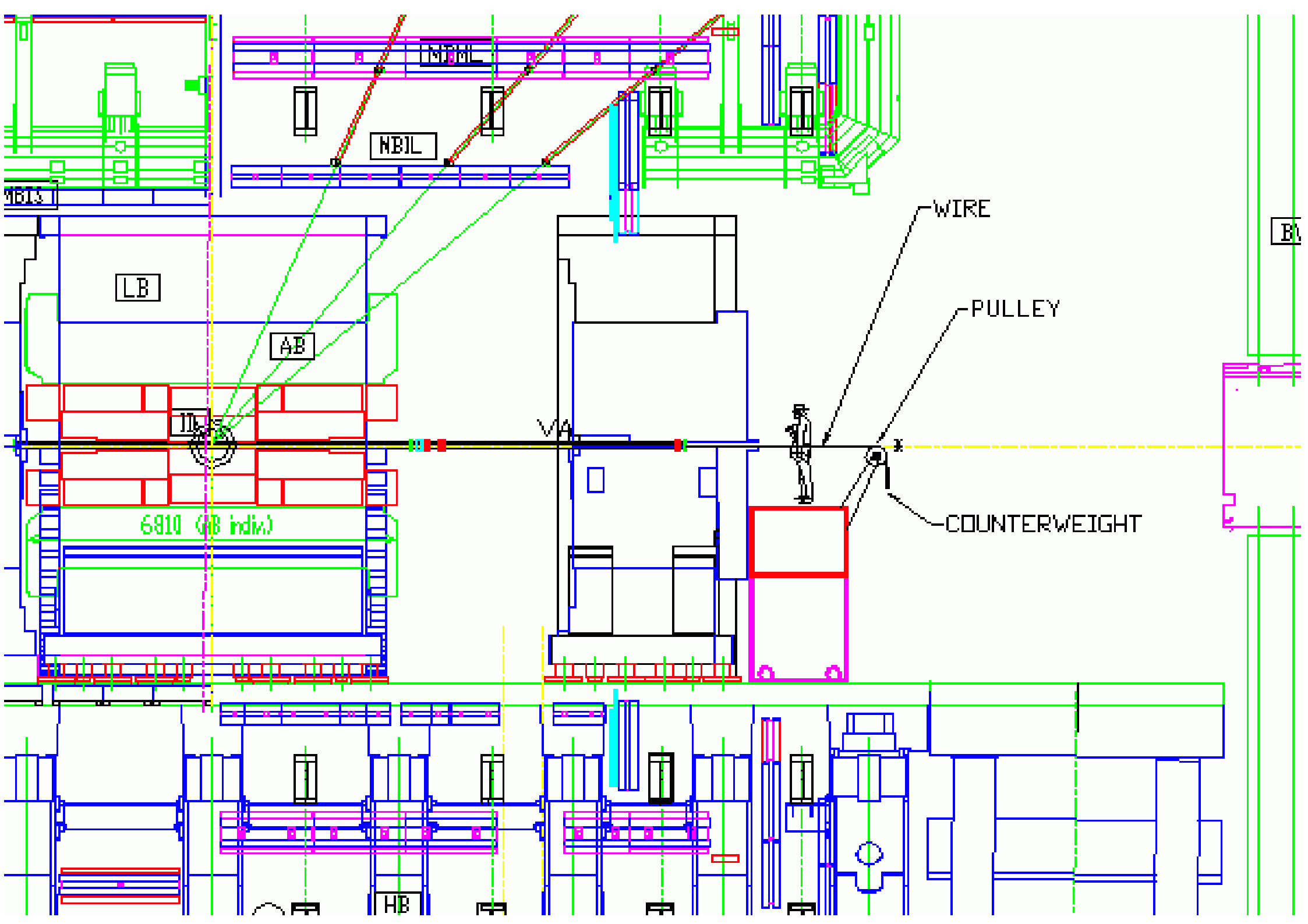

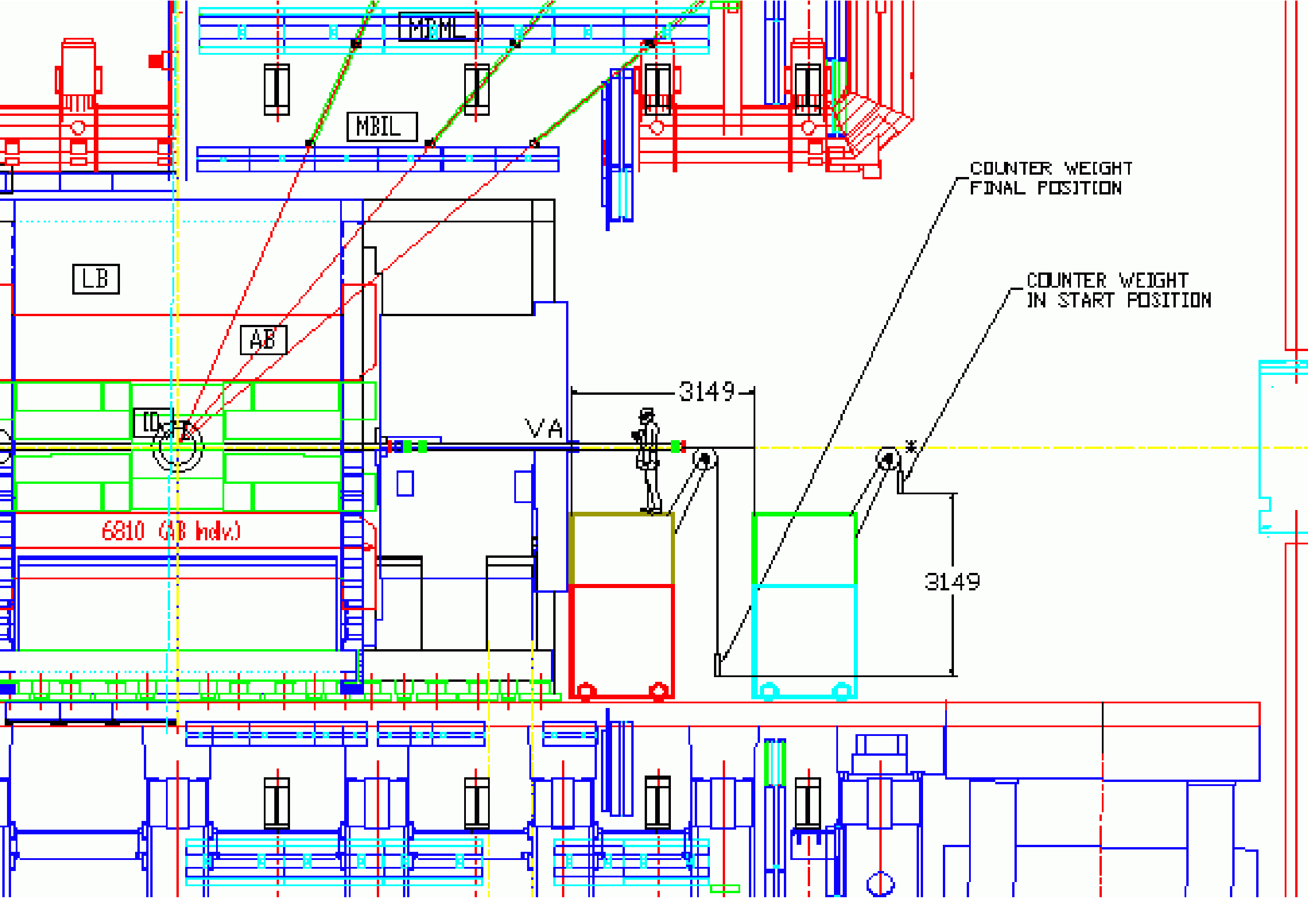

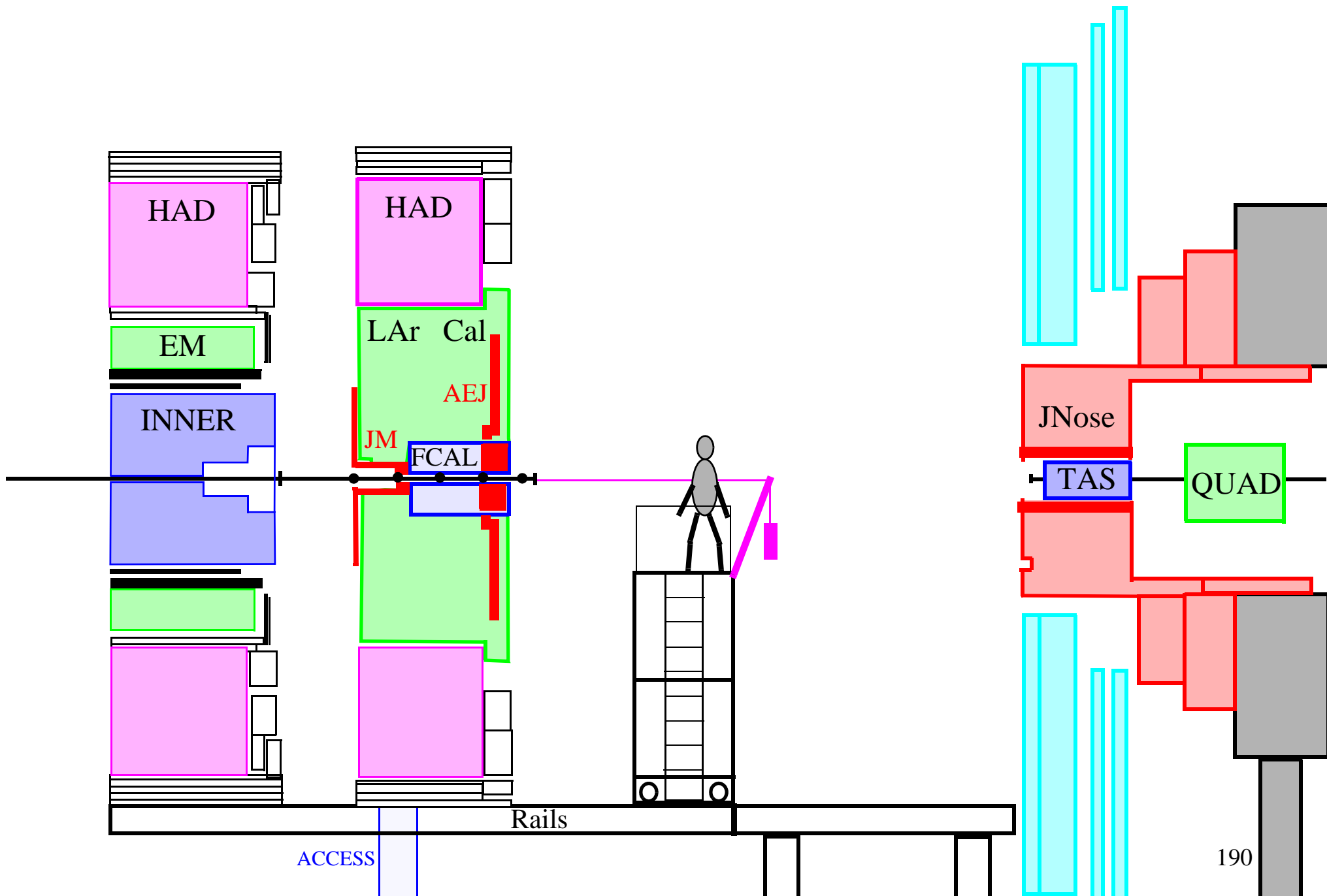

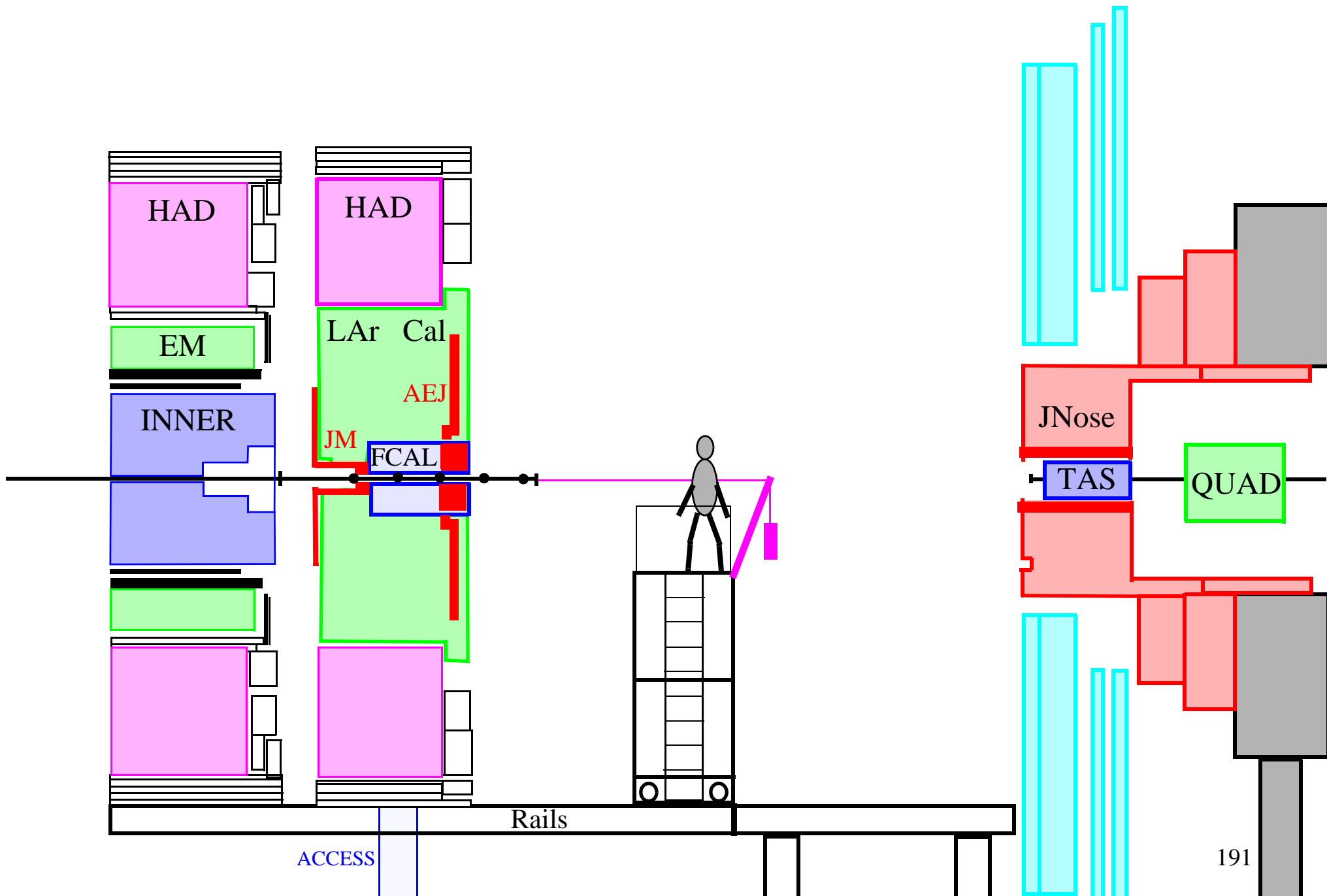

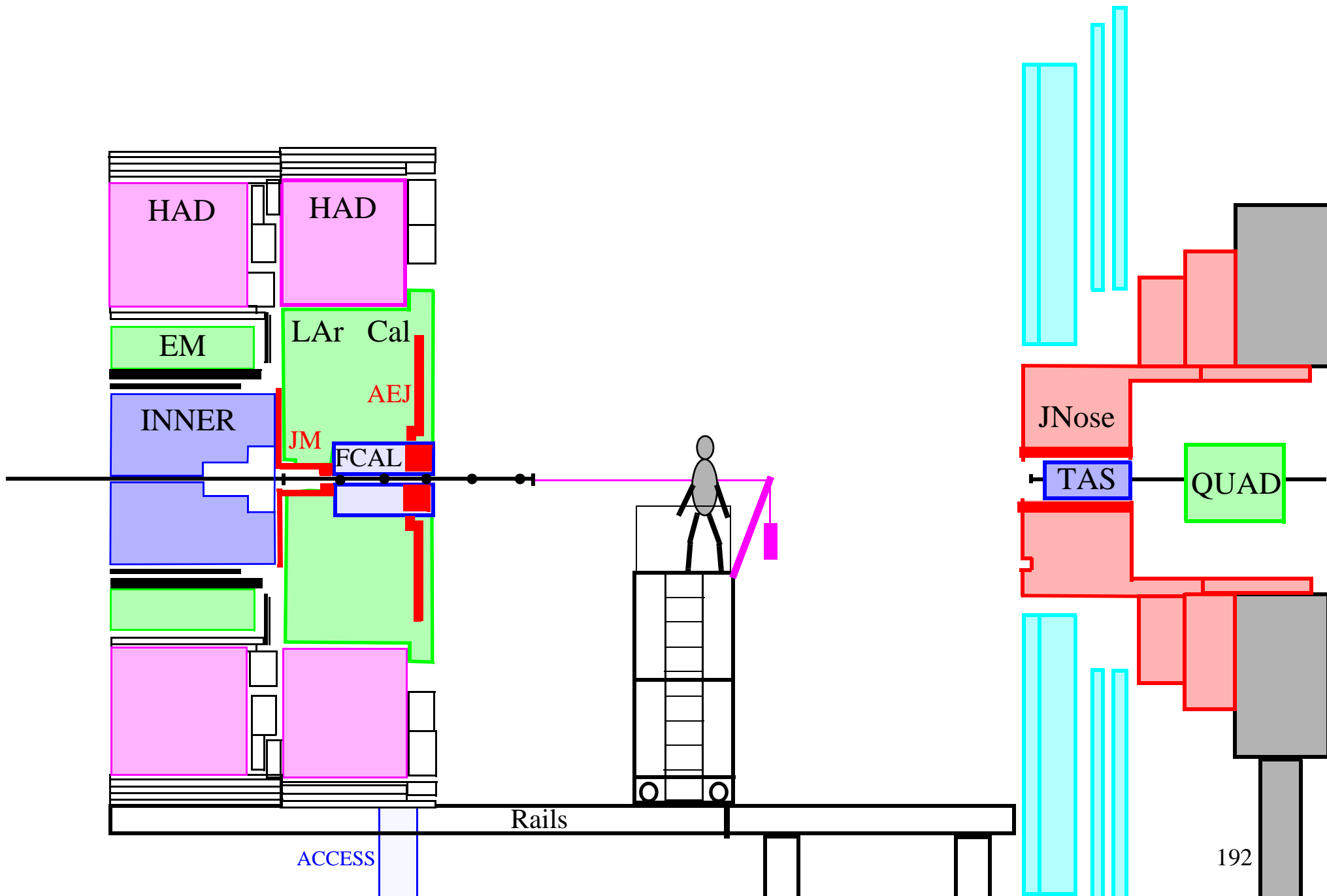

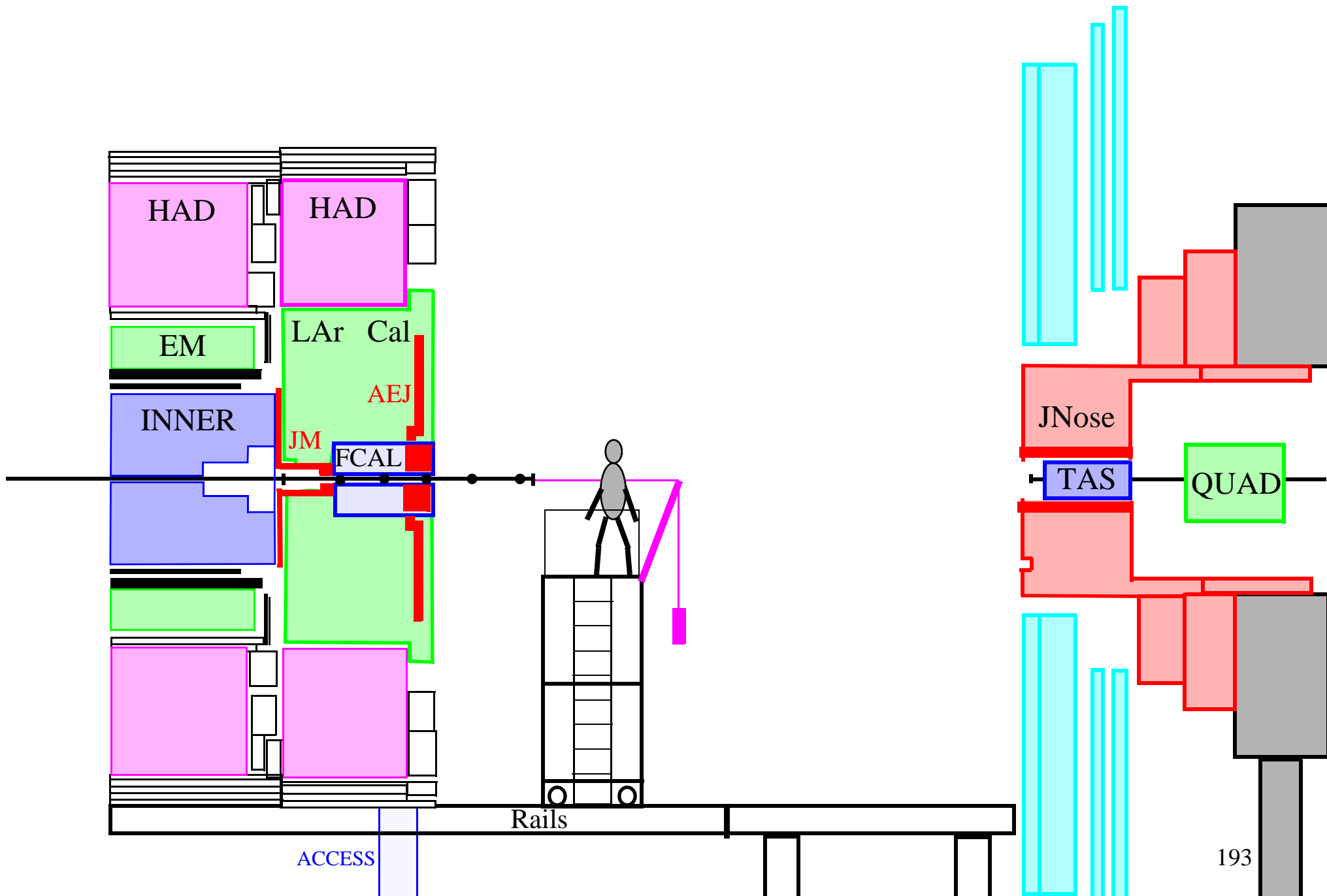

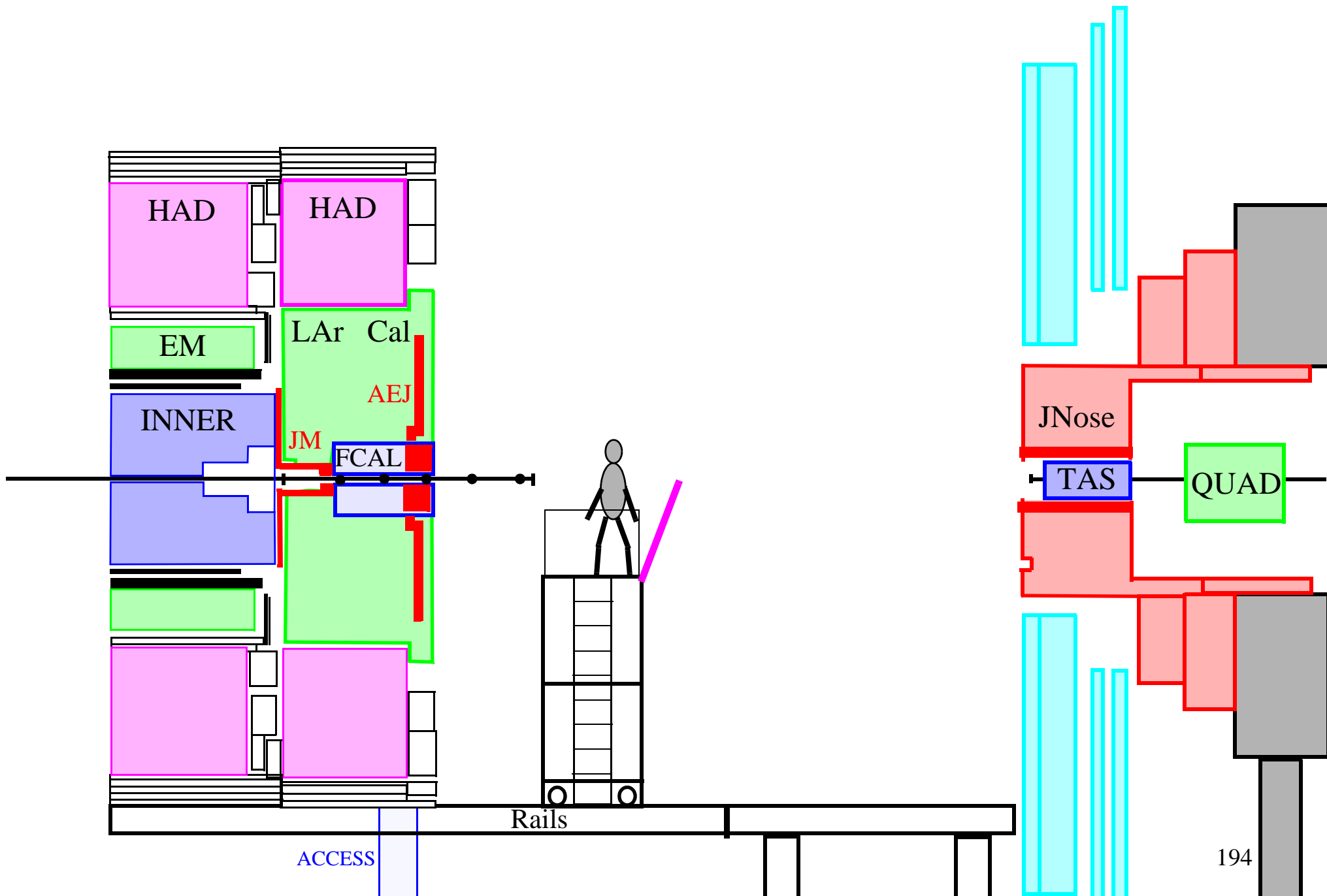

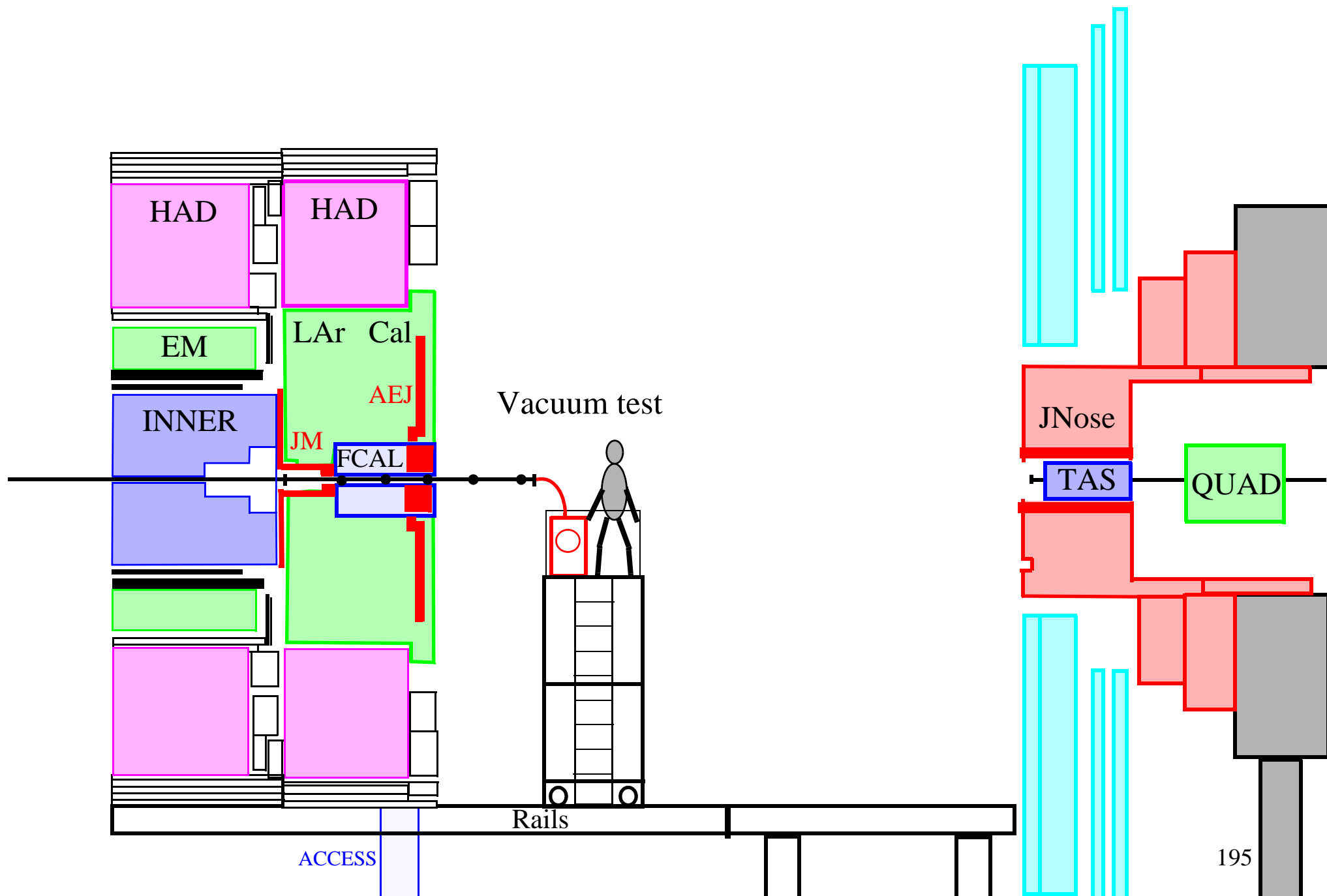

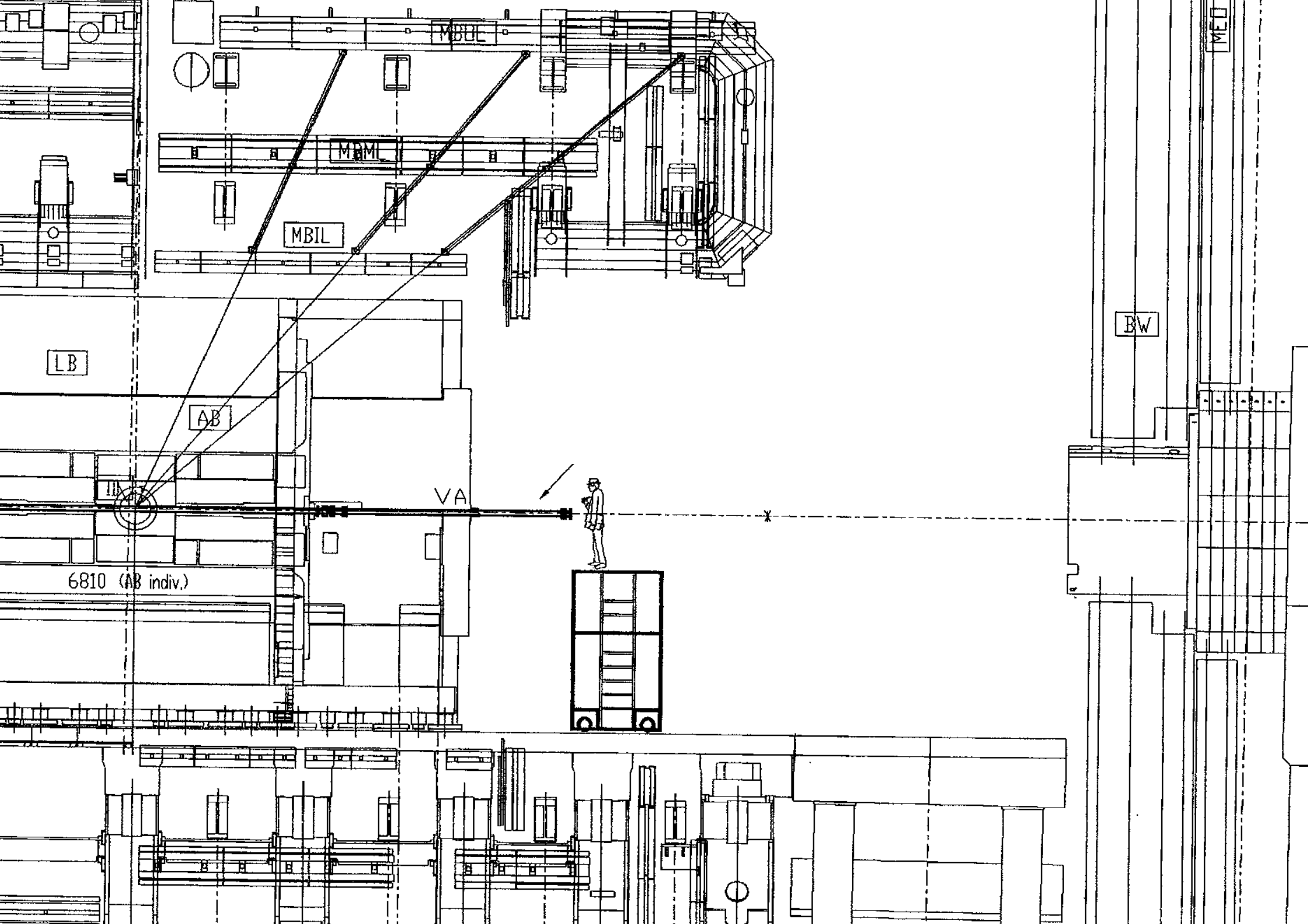

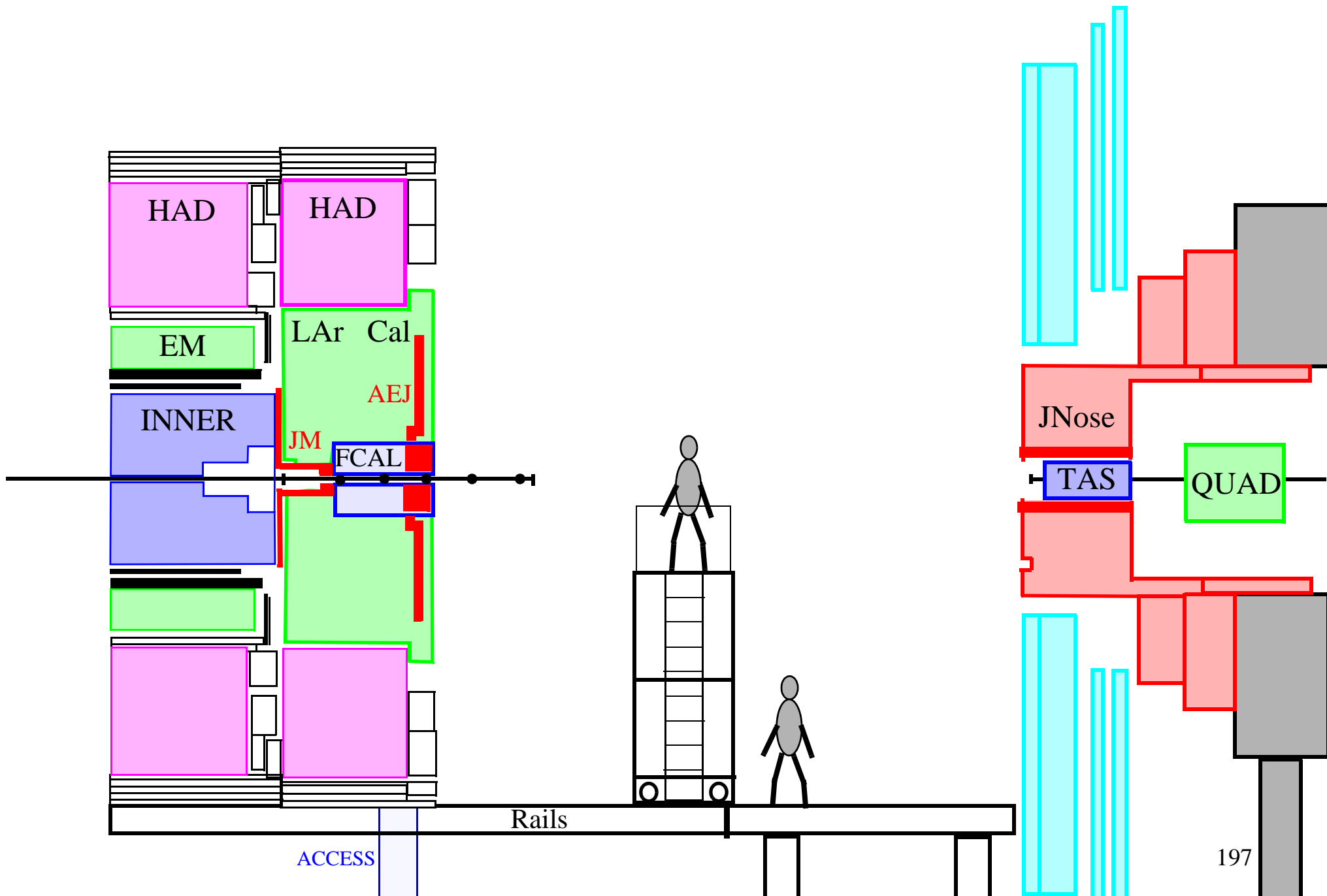

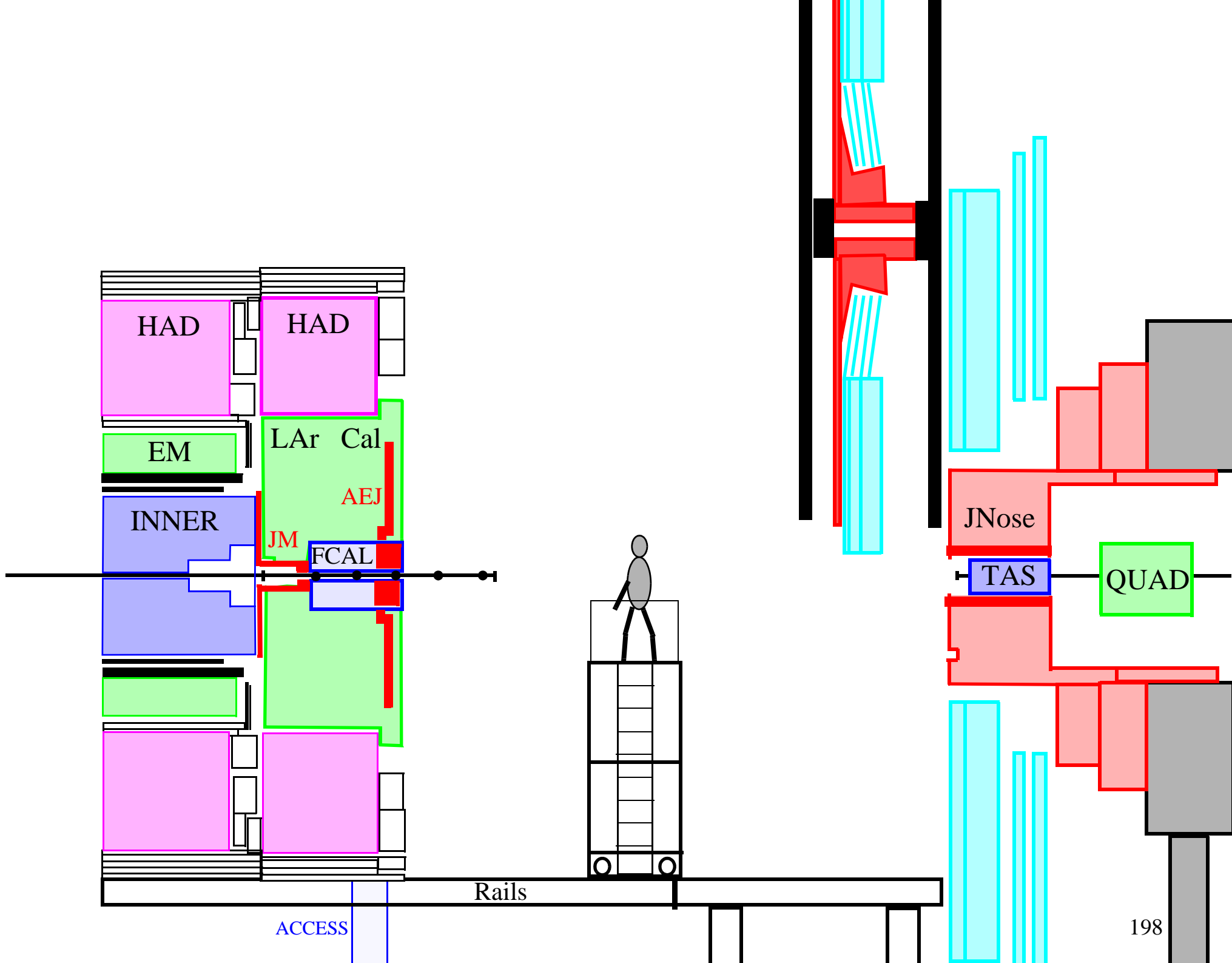

HAD

HAD

EM

LAr Cal

INNER

AEJ

JM

FCAL

JNose

TAS

QUAD

Rails

ACCESS

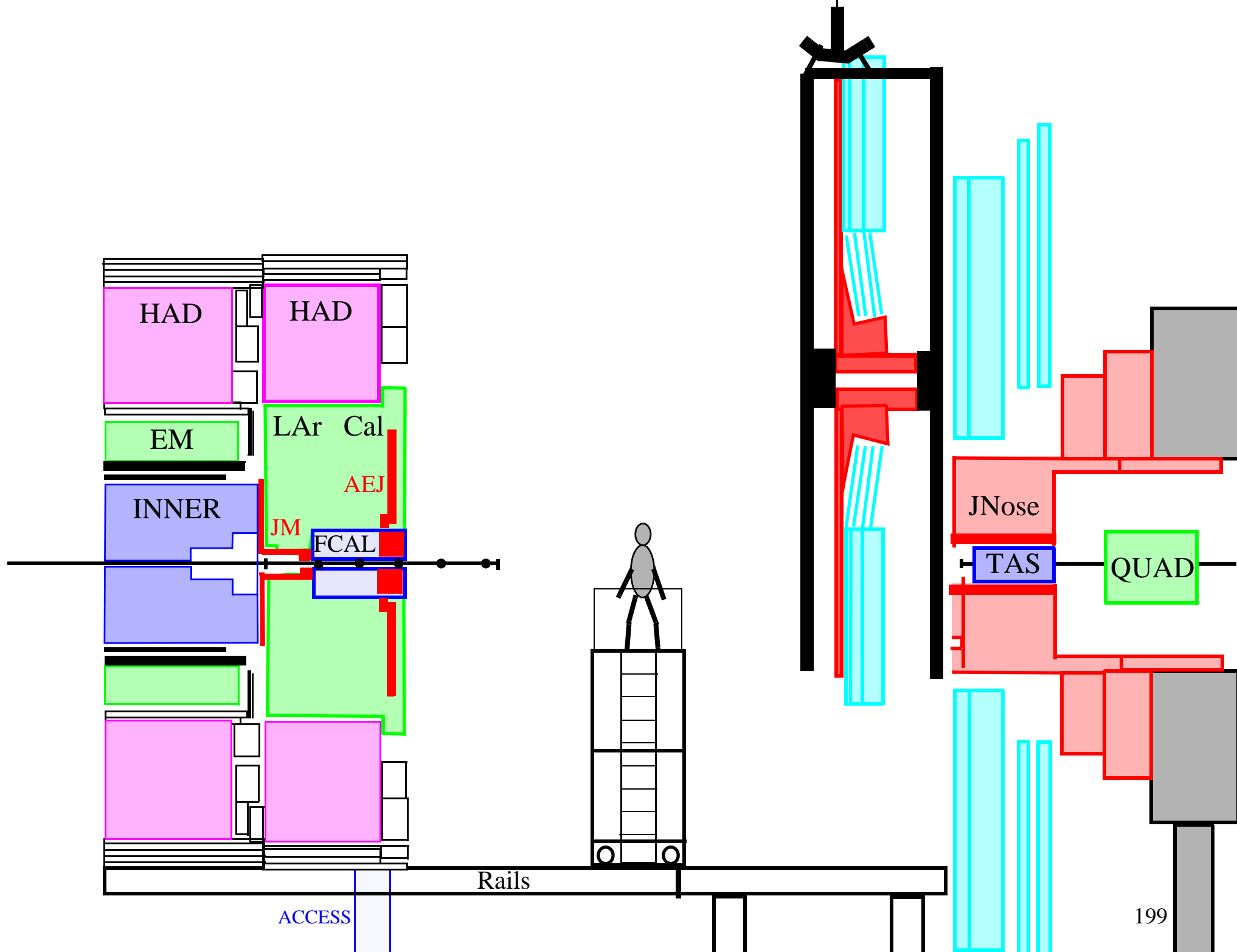

The JD/SW has to be moved in sideways to get under the ECT services.

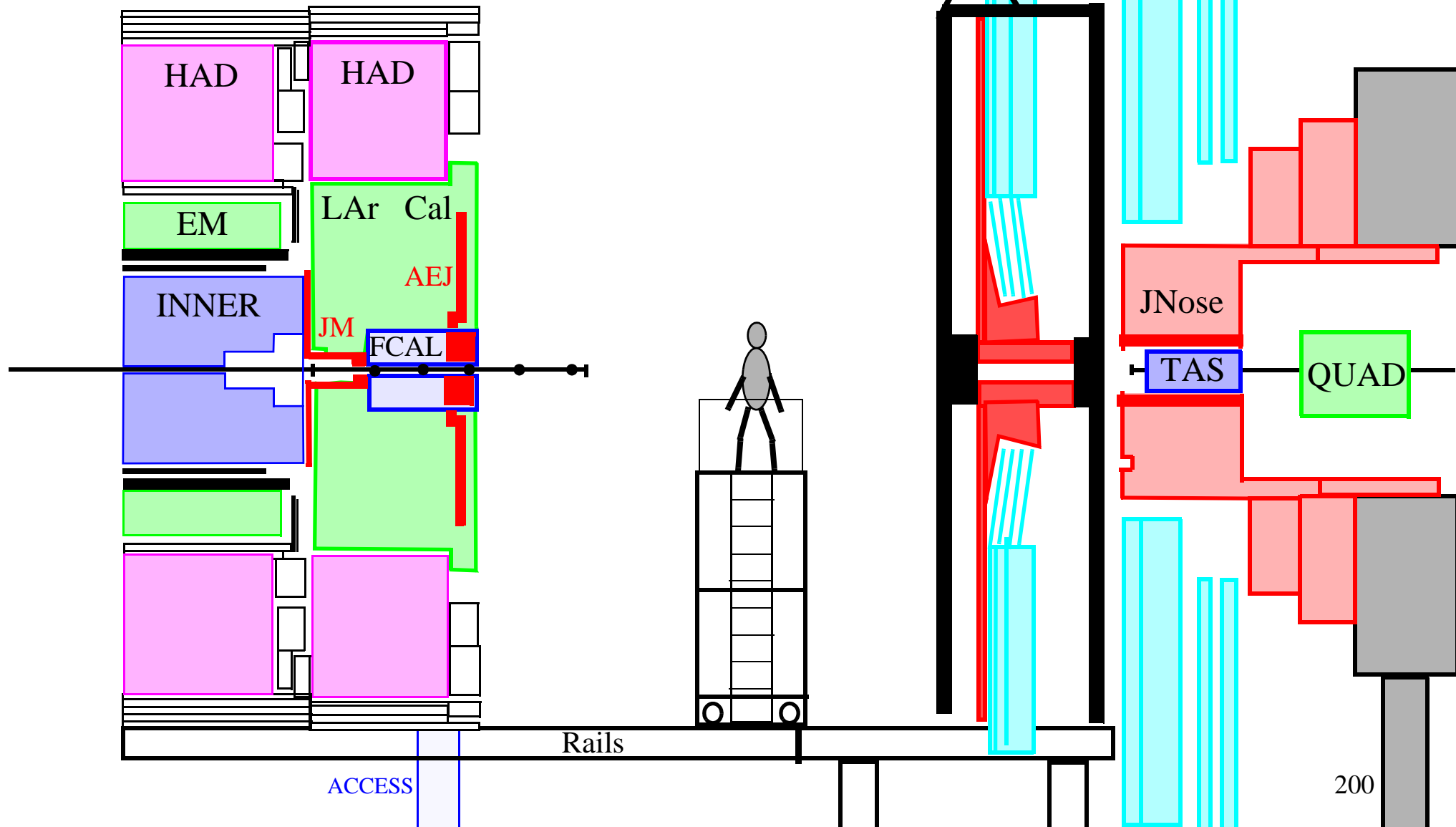

20 T THEORETICAL ZONE

20 T SAFETY ZONE

20 F EXTENDED ZONE

ECT

Liftingpoints

JD

JN

15787

437

1475

1664

800

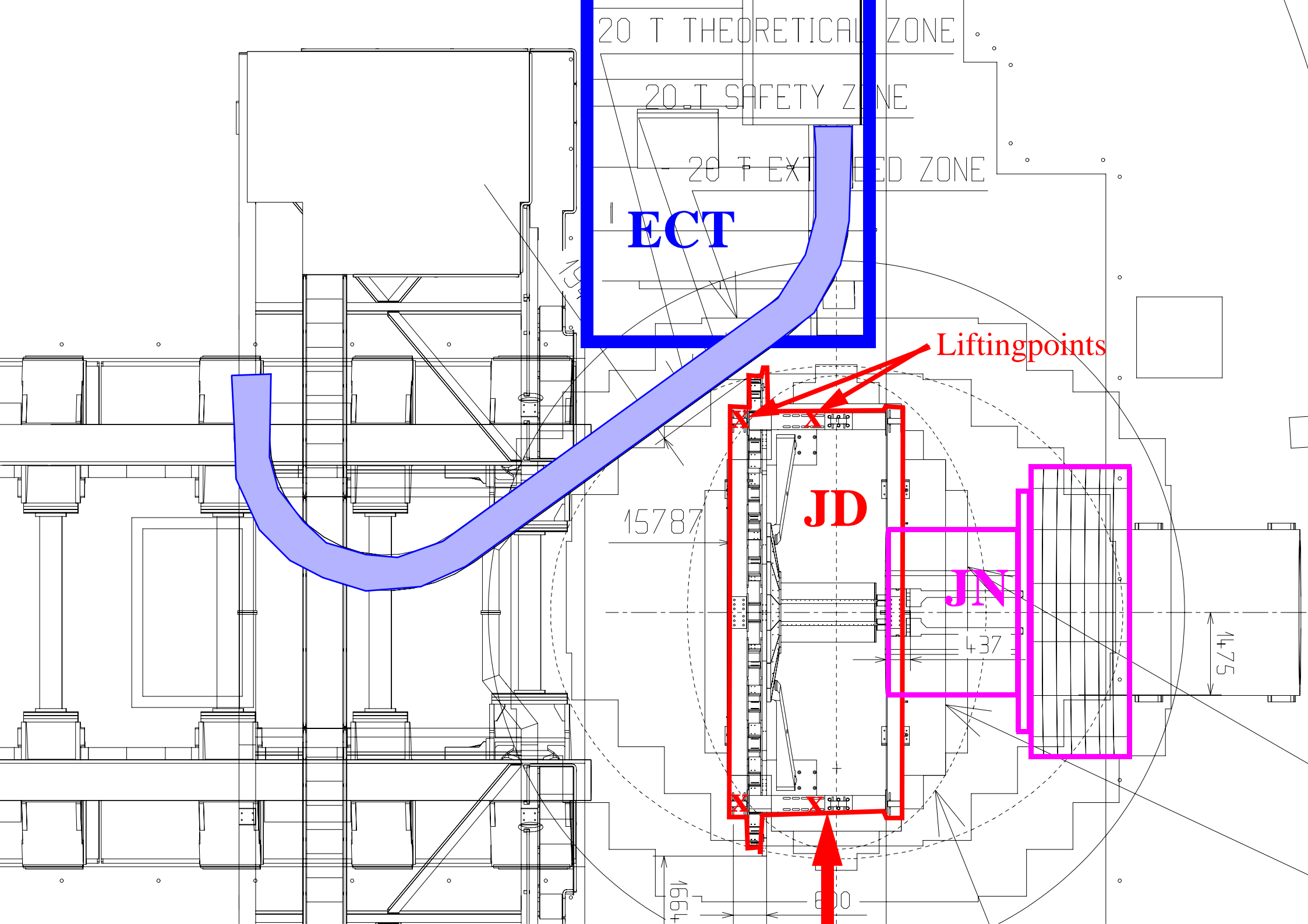

The JD/SW has to be moved towards the IP on its airpads.

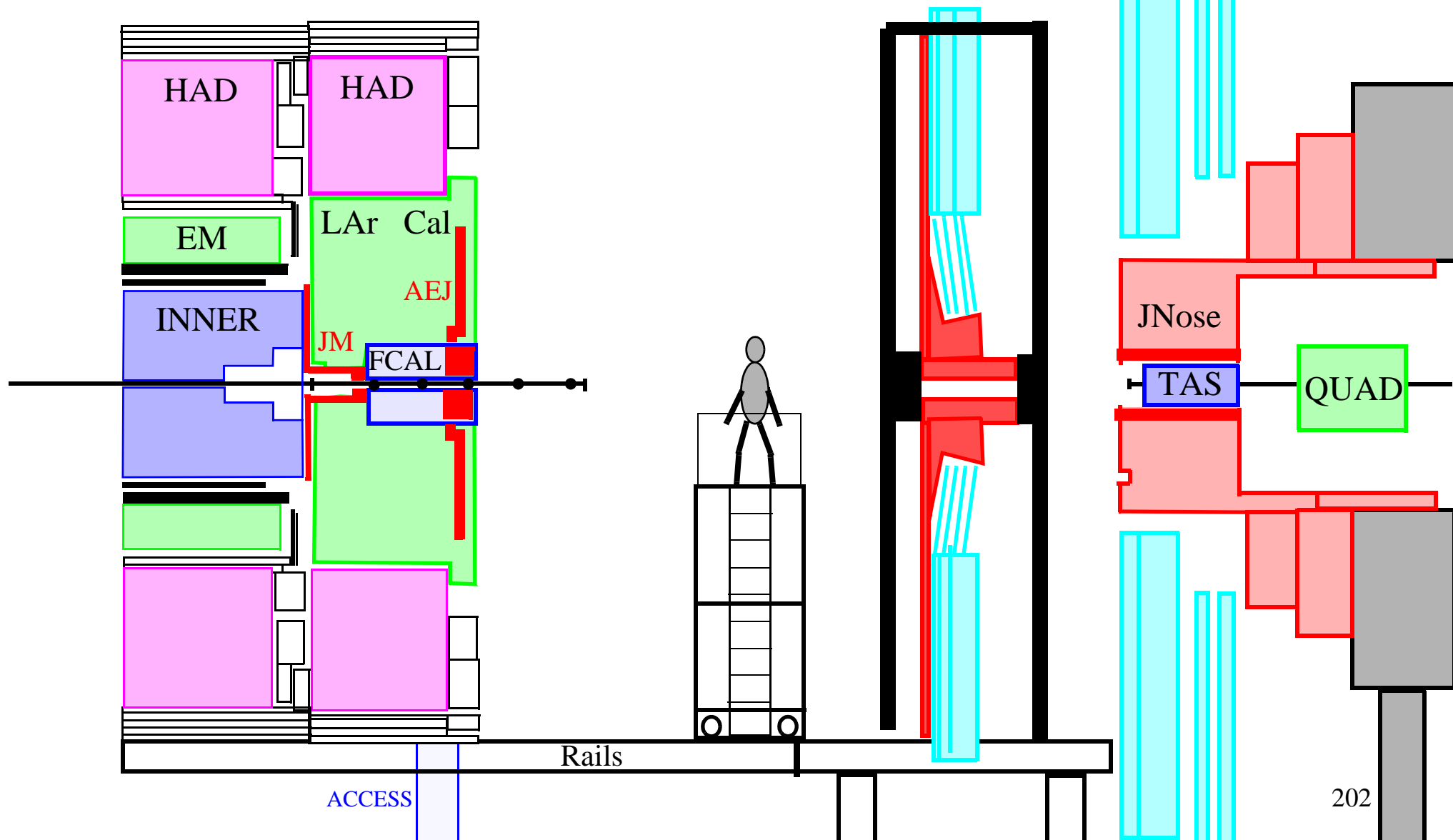

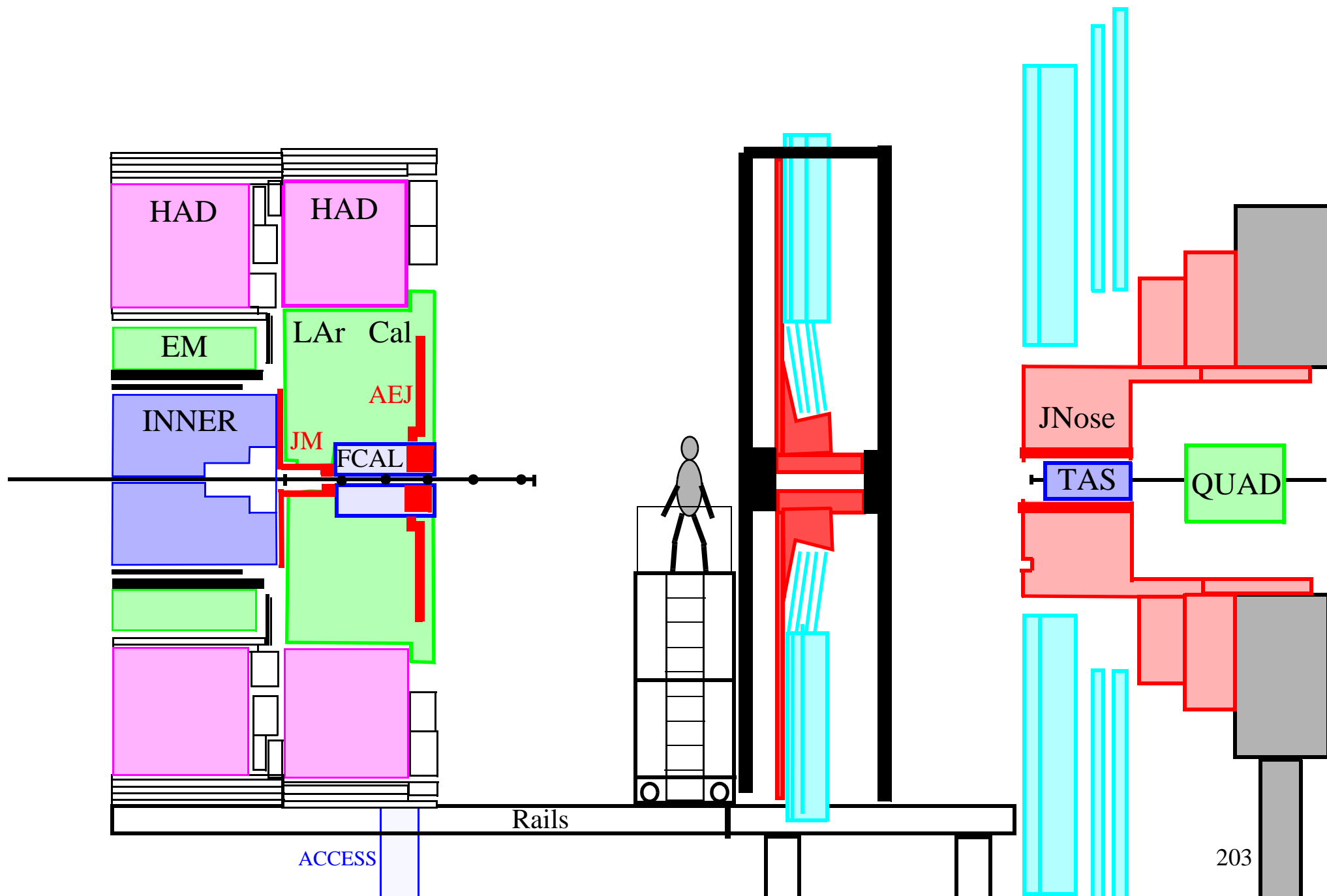

20 T THEORETICAL ZONE

20 T SAFETY ZONE

20 F EXTENDED ZONE

ECT

JD

15787

JN

437

1475

1564

600

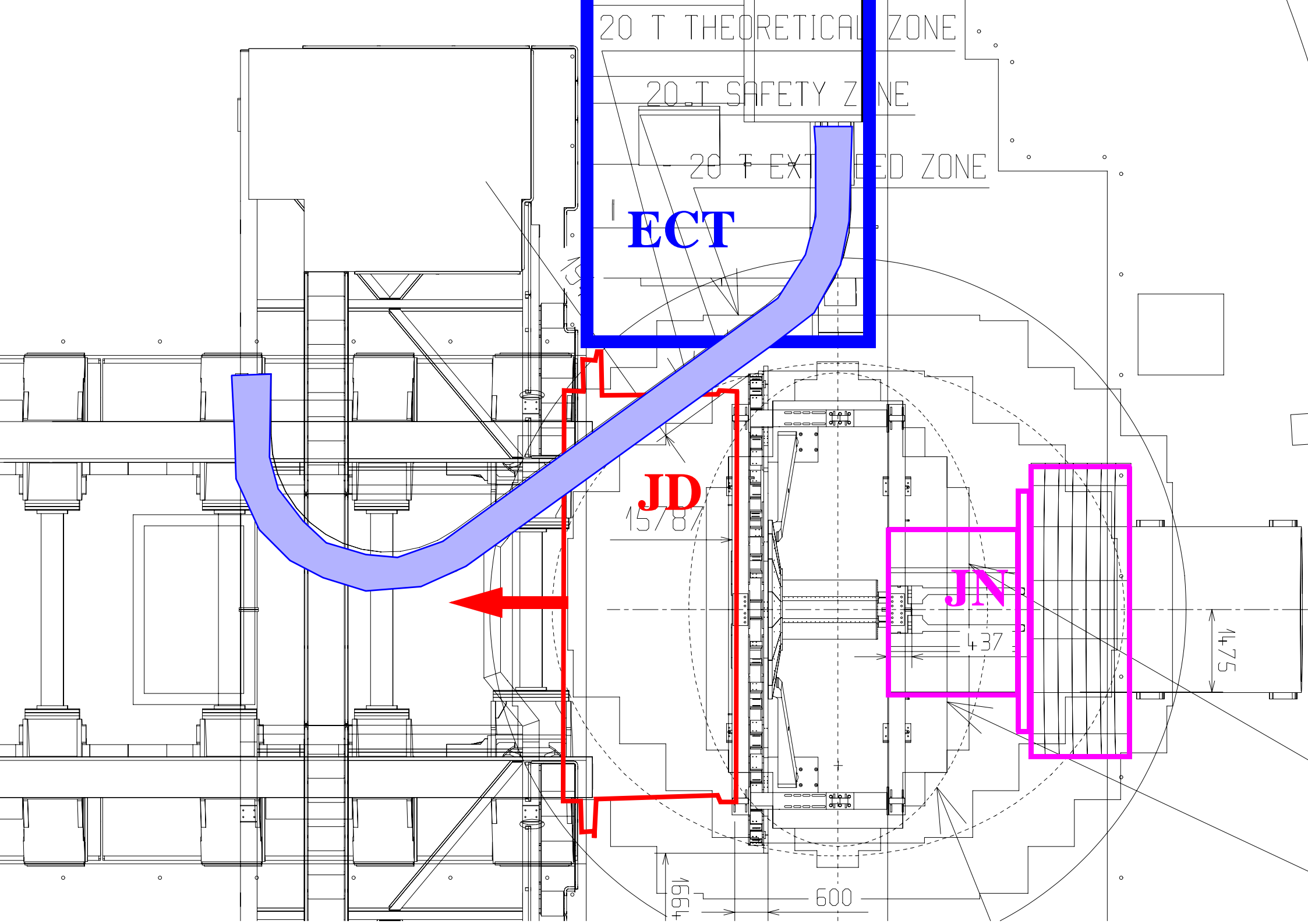

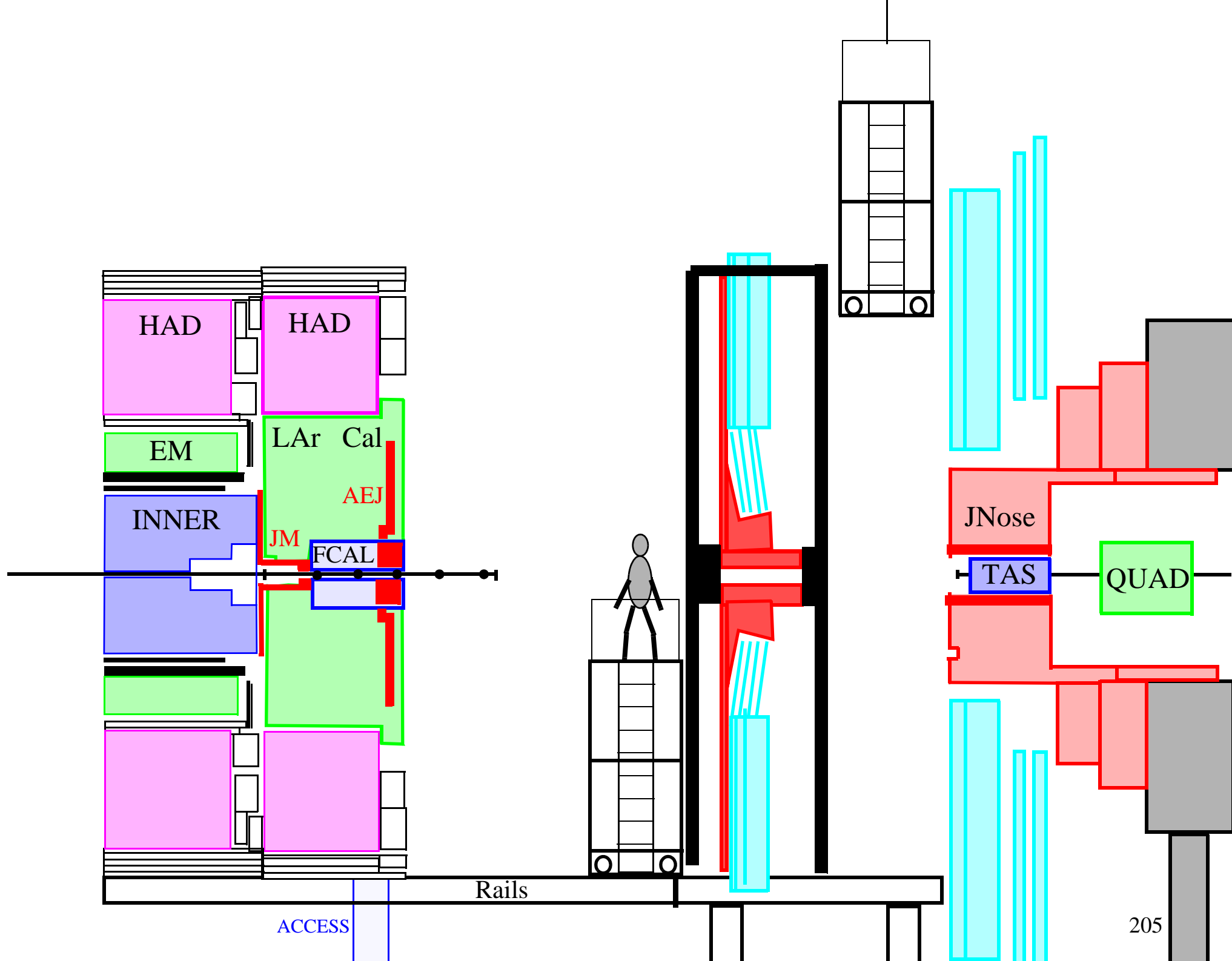

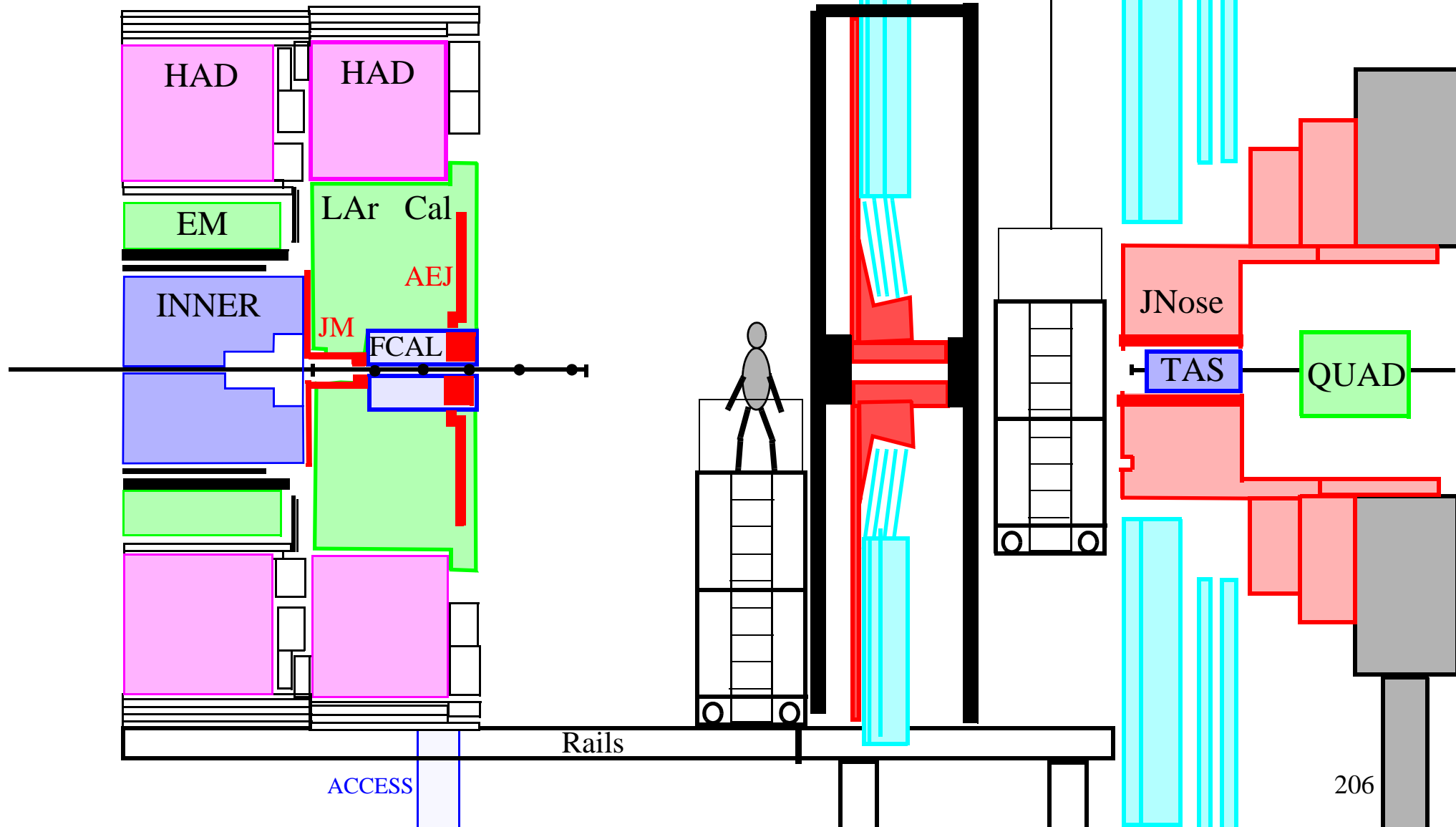

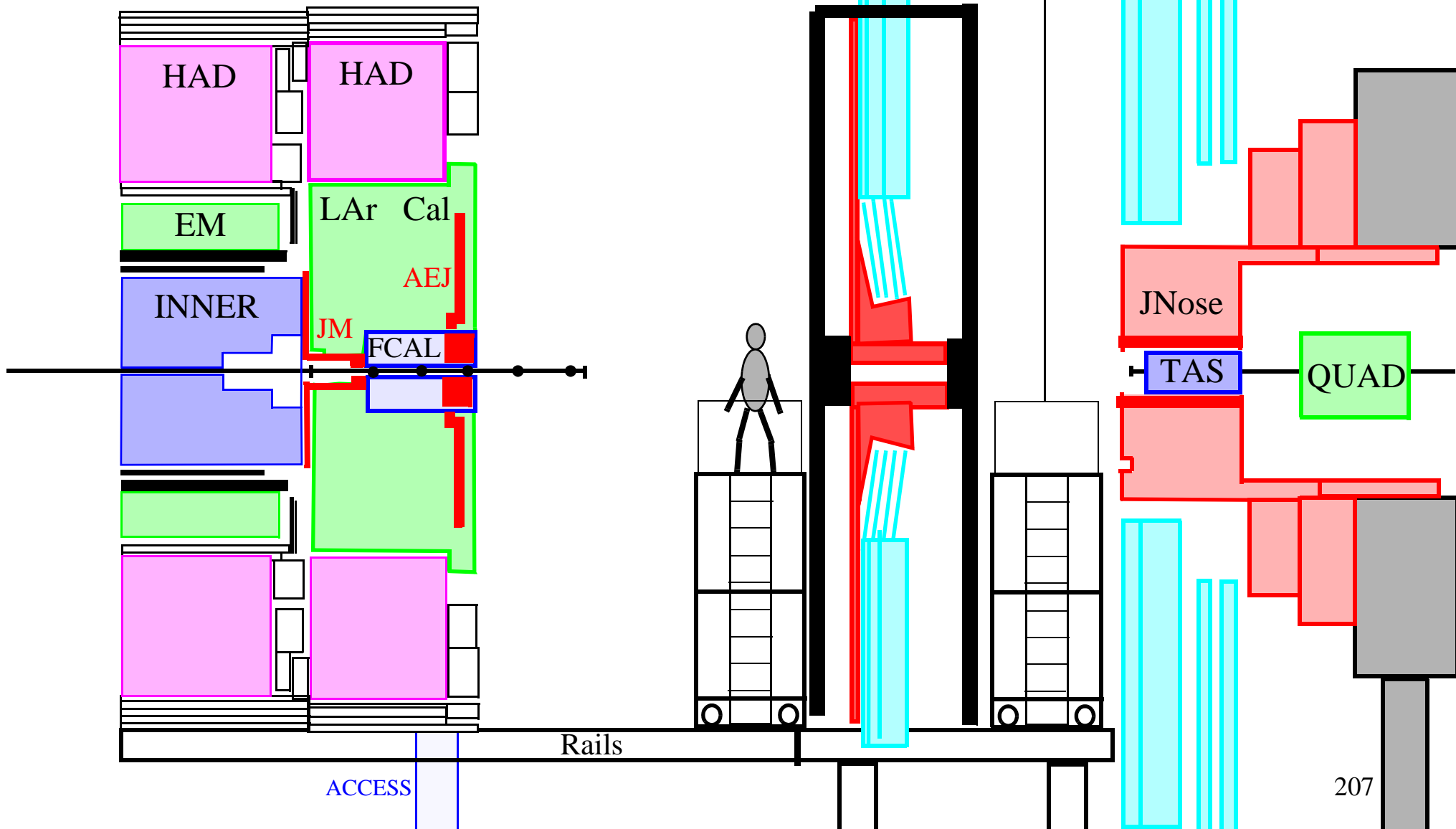

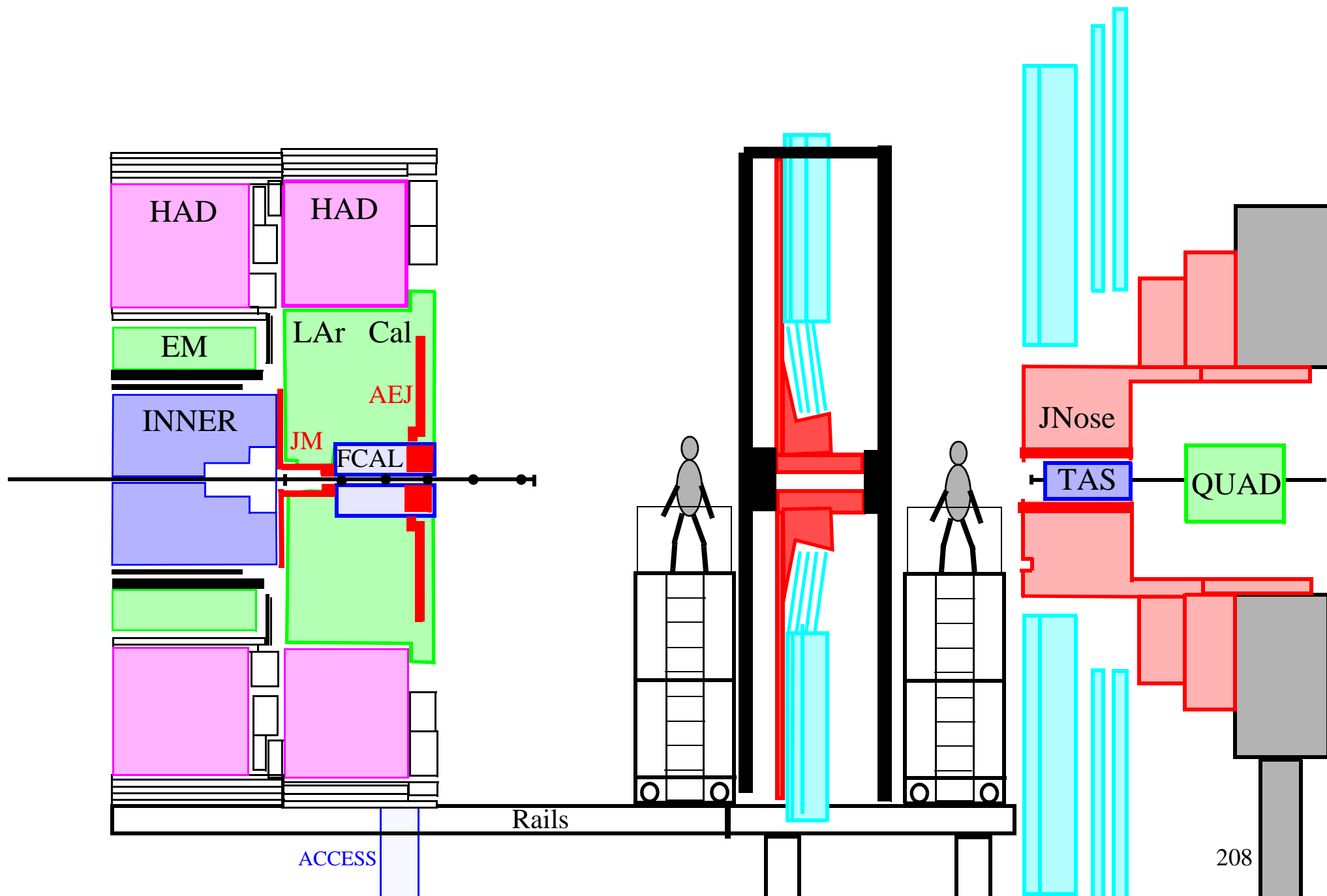

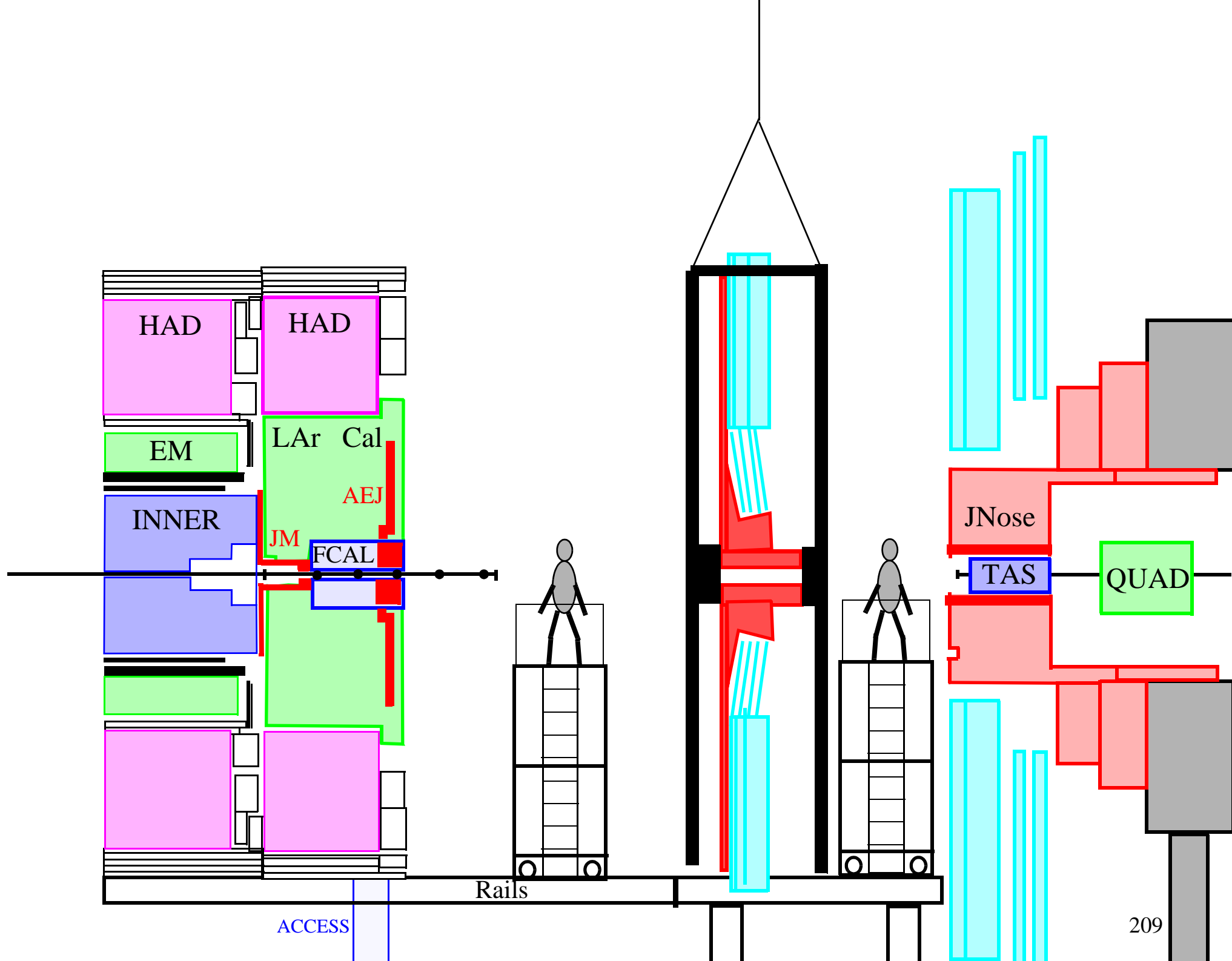

20 T THEORETICAL ZONE

20 T SAFETY ZONE

20 F EXTENDED ZONE

ECT

New
Liftingpoints

JD

JN

15787

437

1475

1564

600

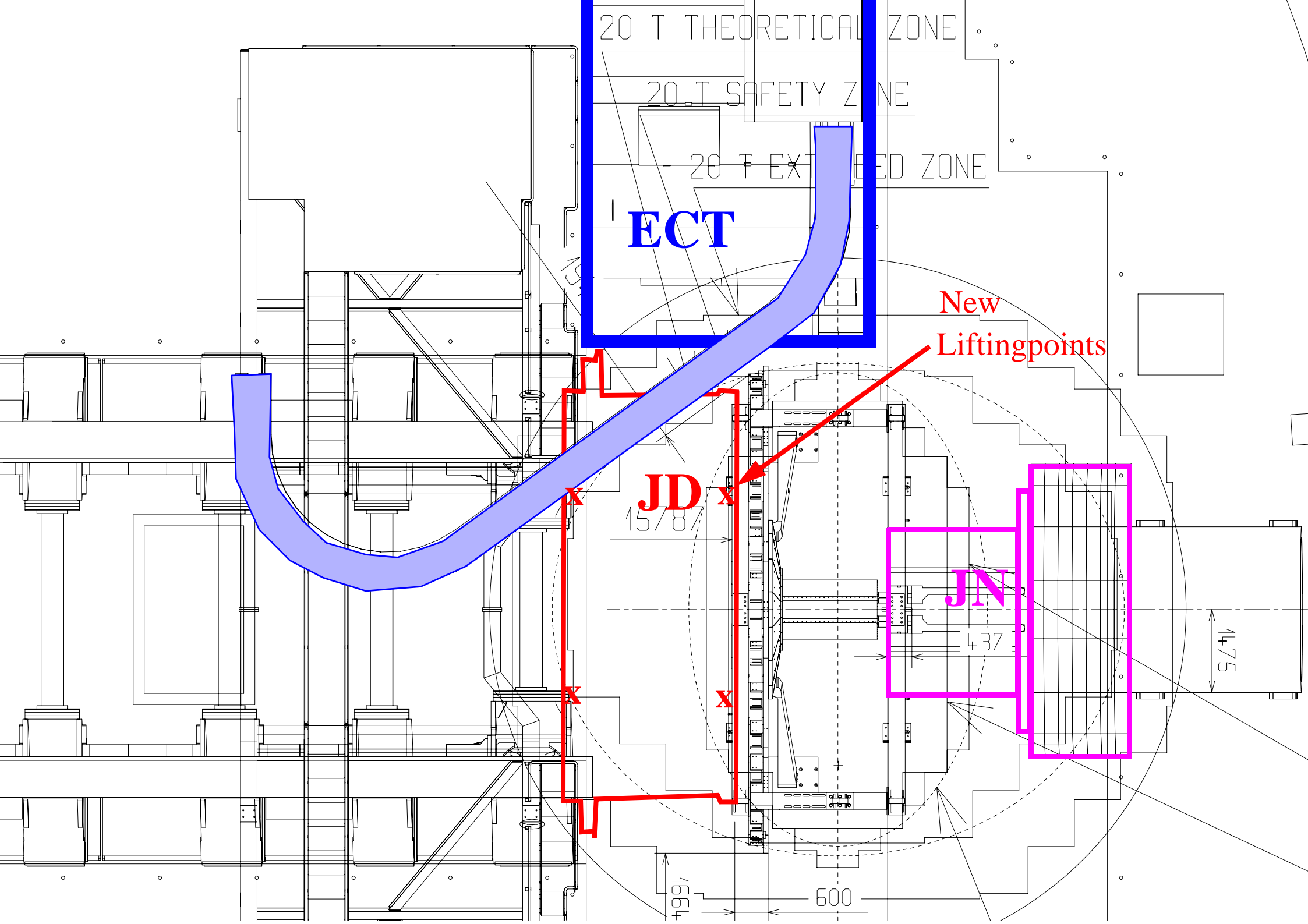

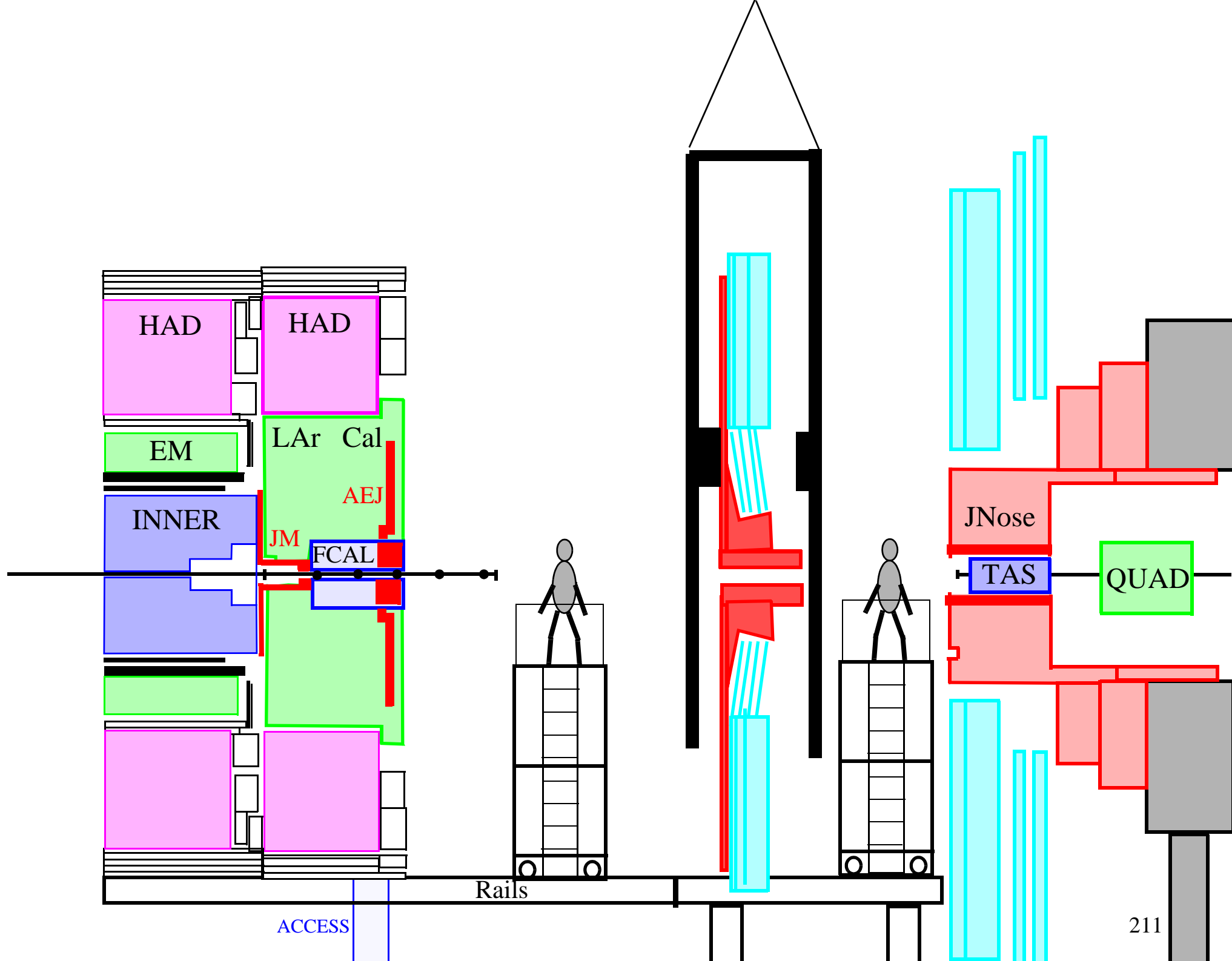

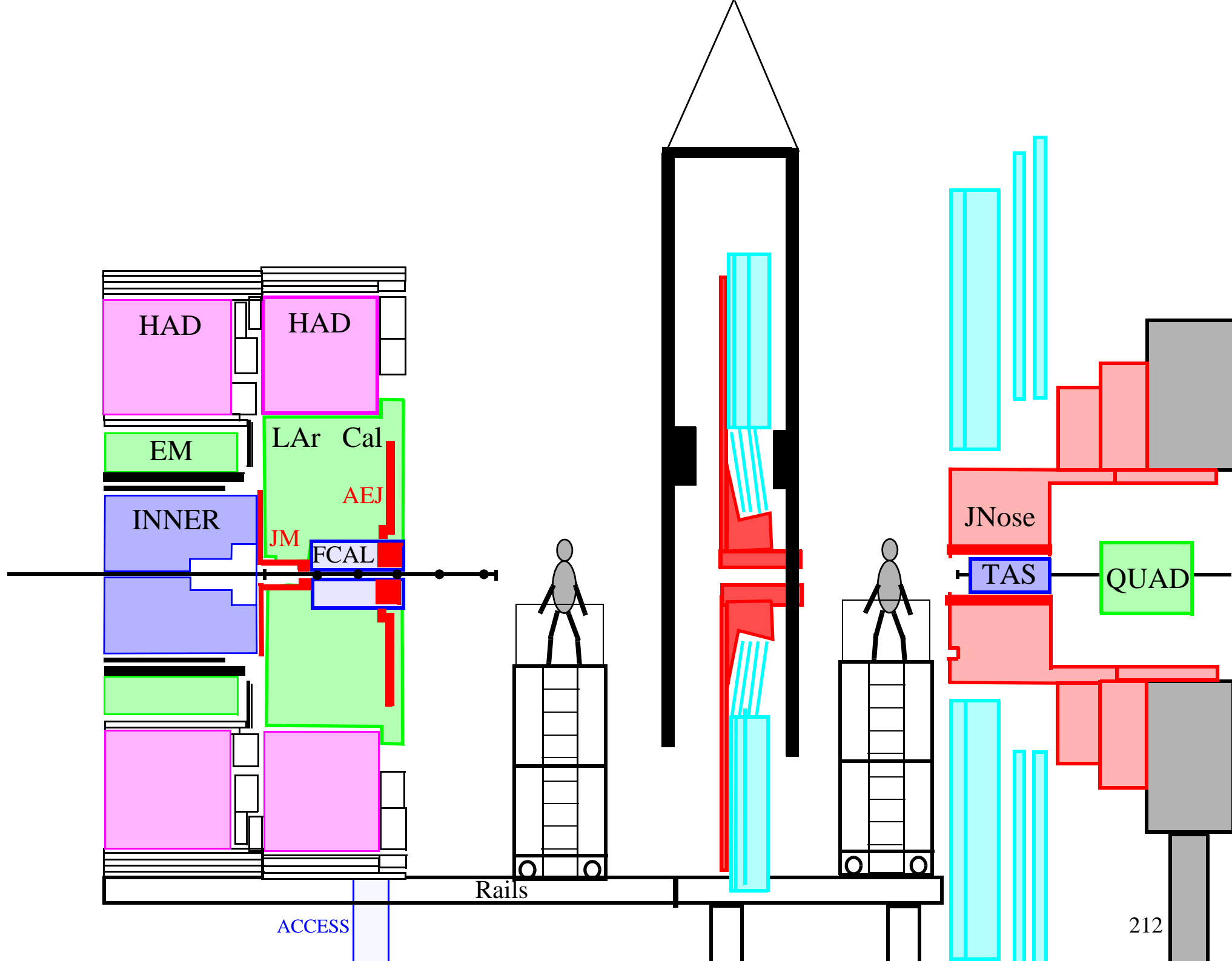

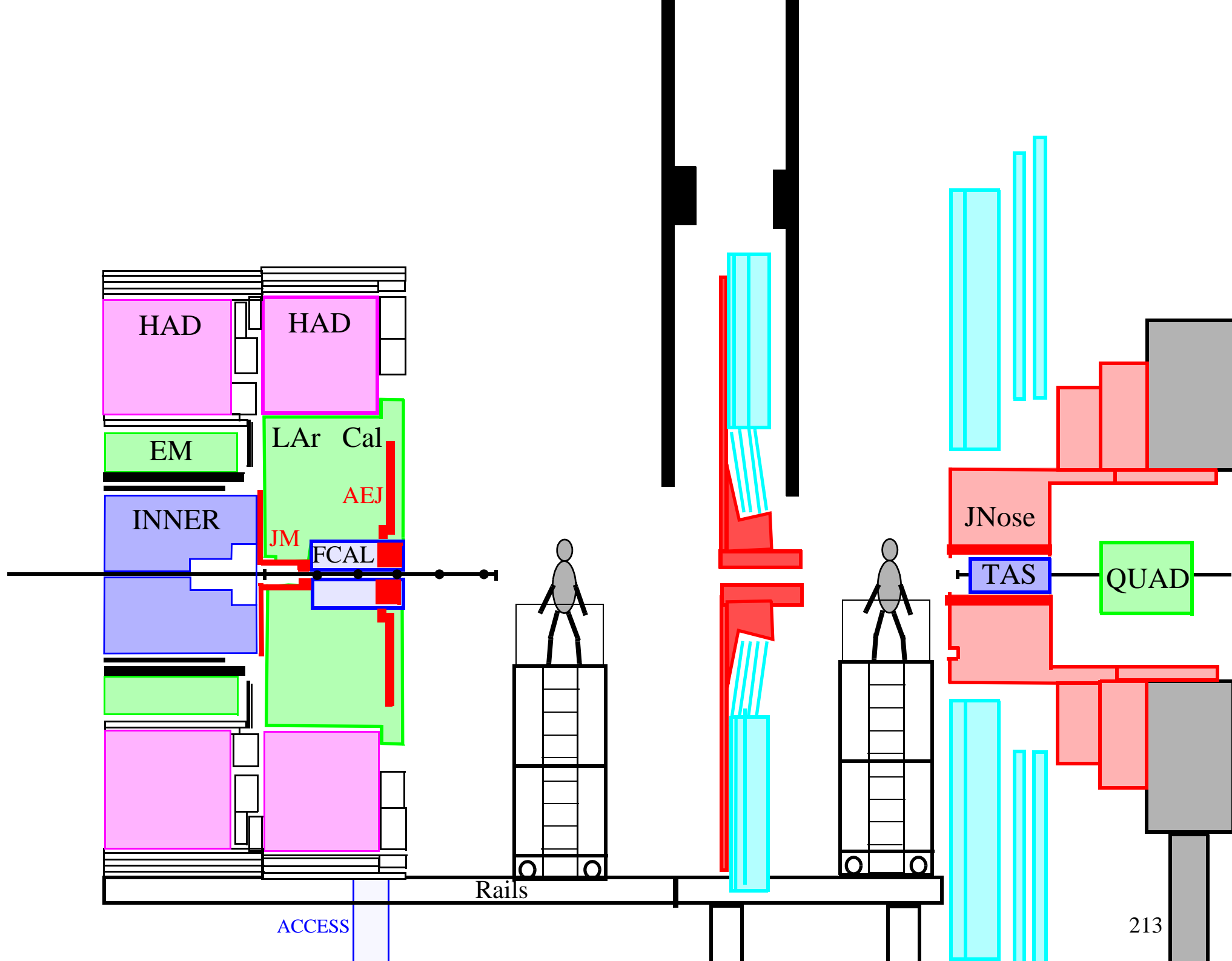

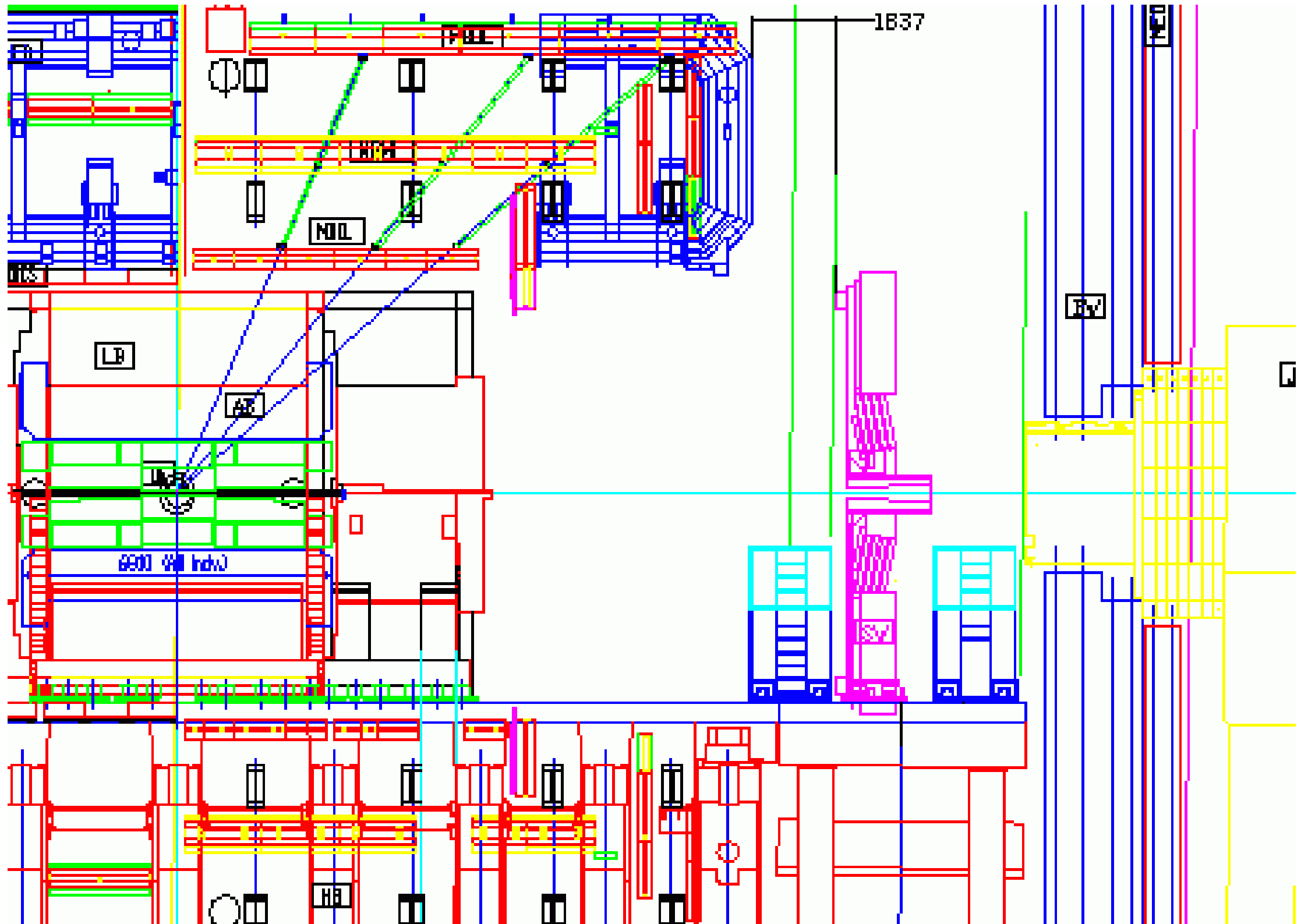

1837

MIL

MIL

MIL

LP

AT

6500 (All Ind)

SW

SW

HA

MED

Q

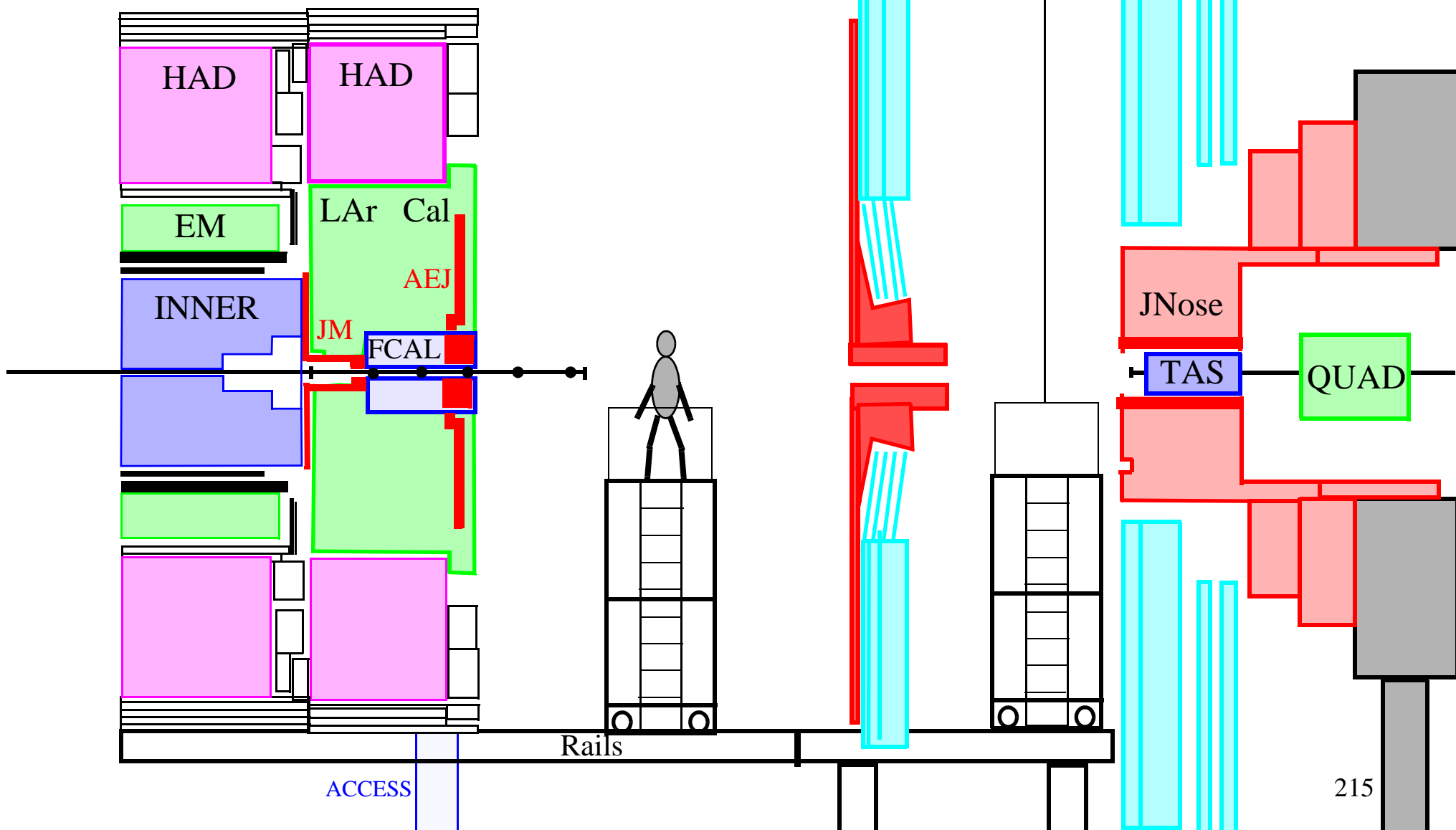

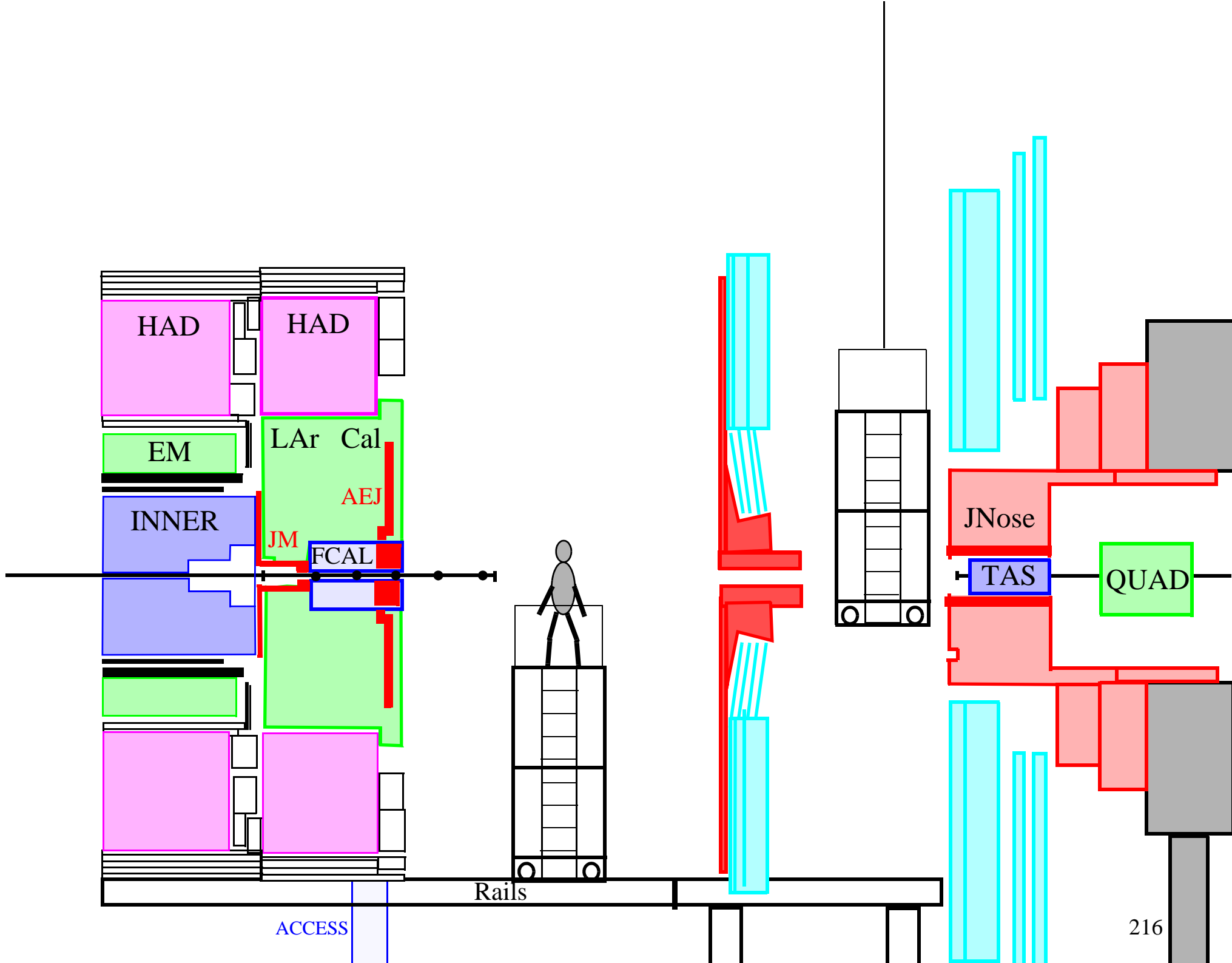

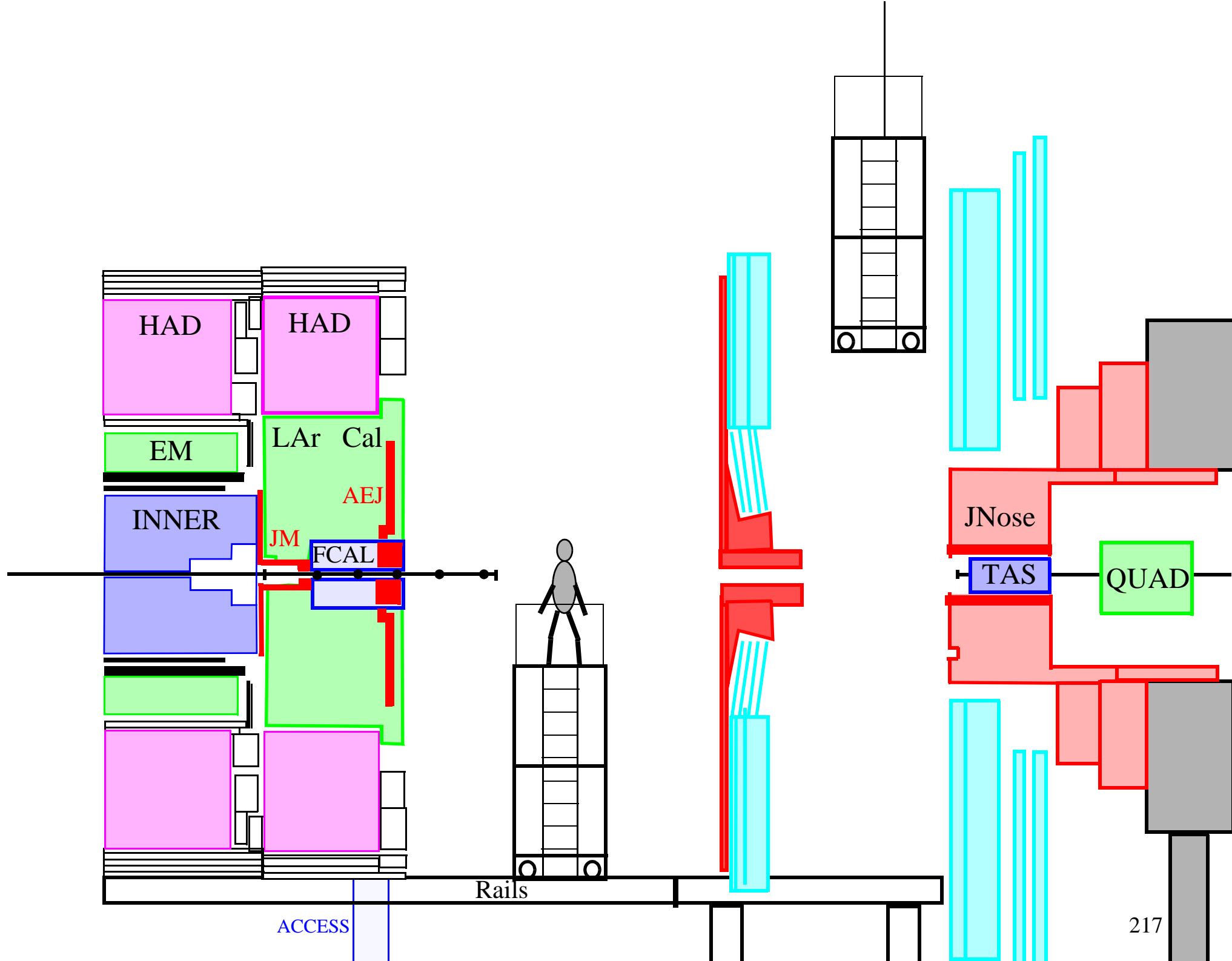

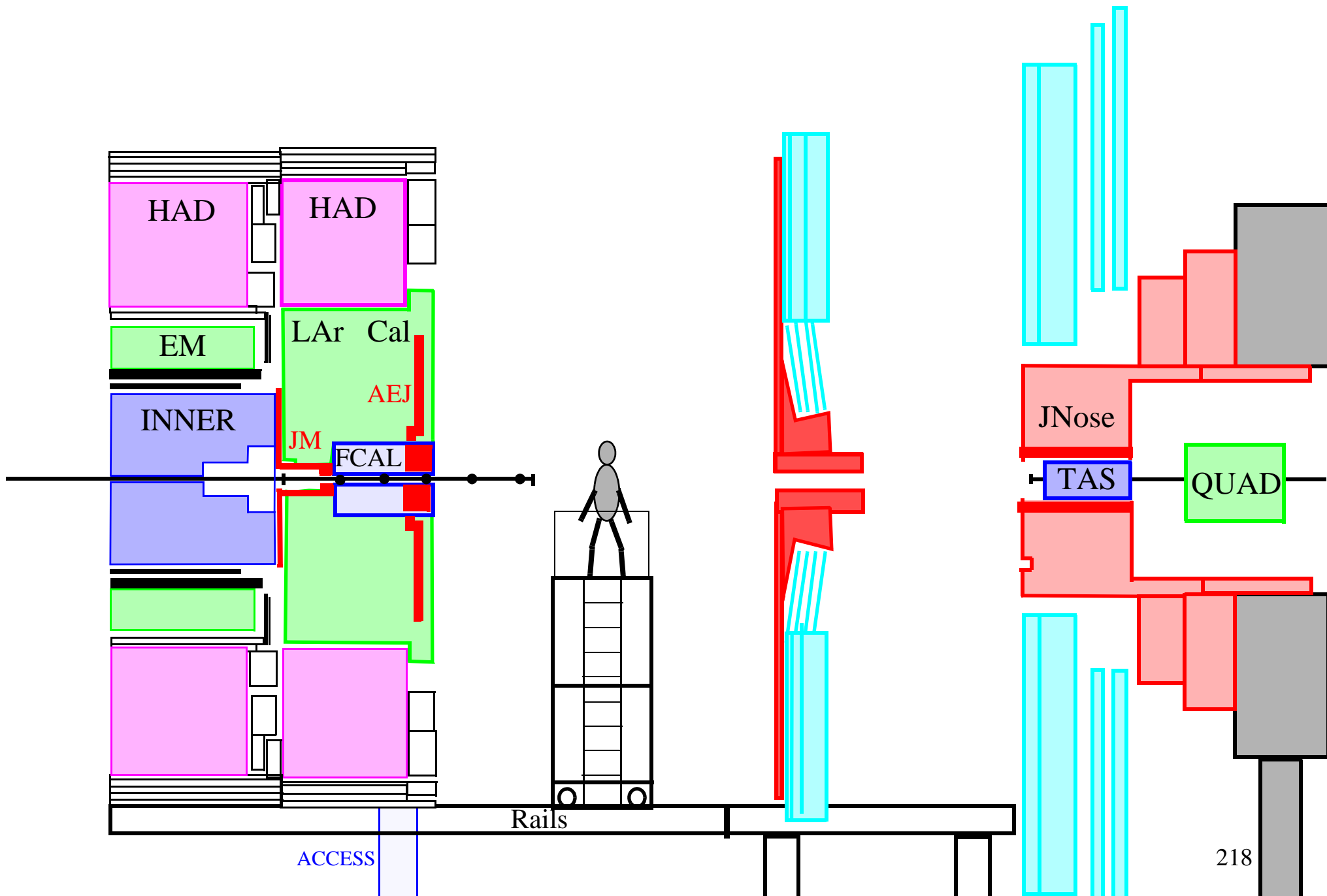

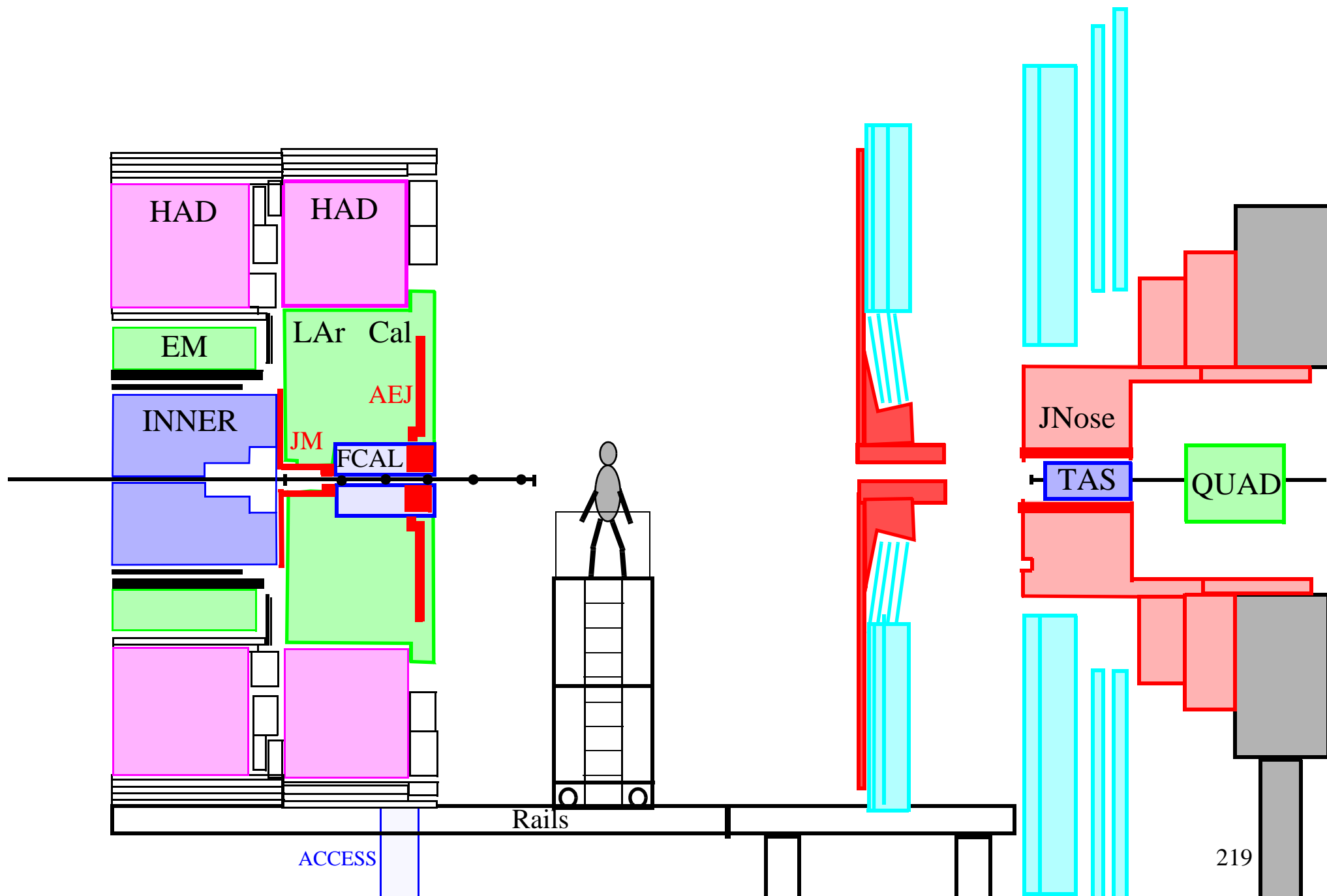

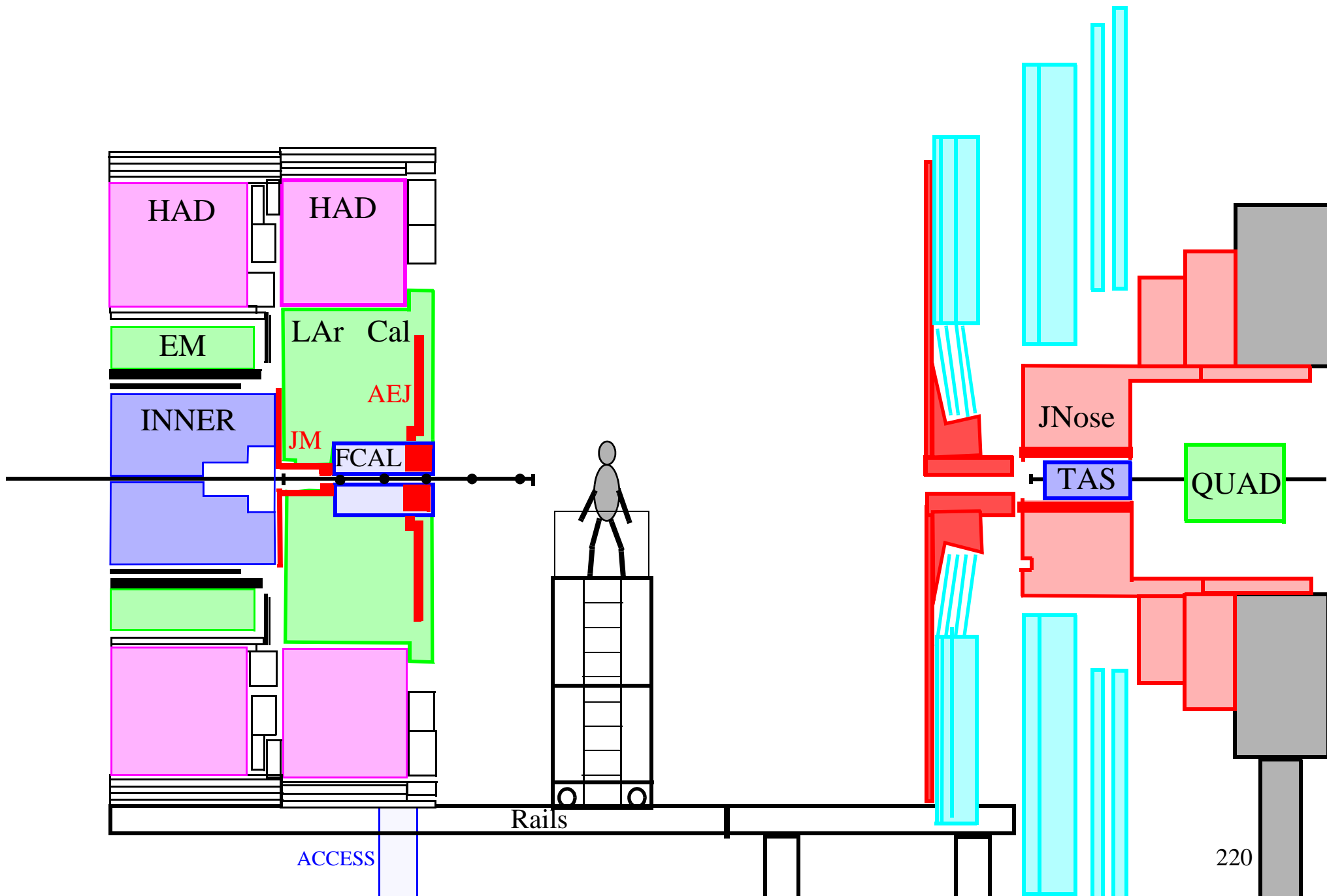

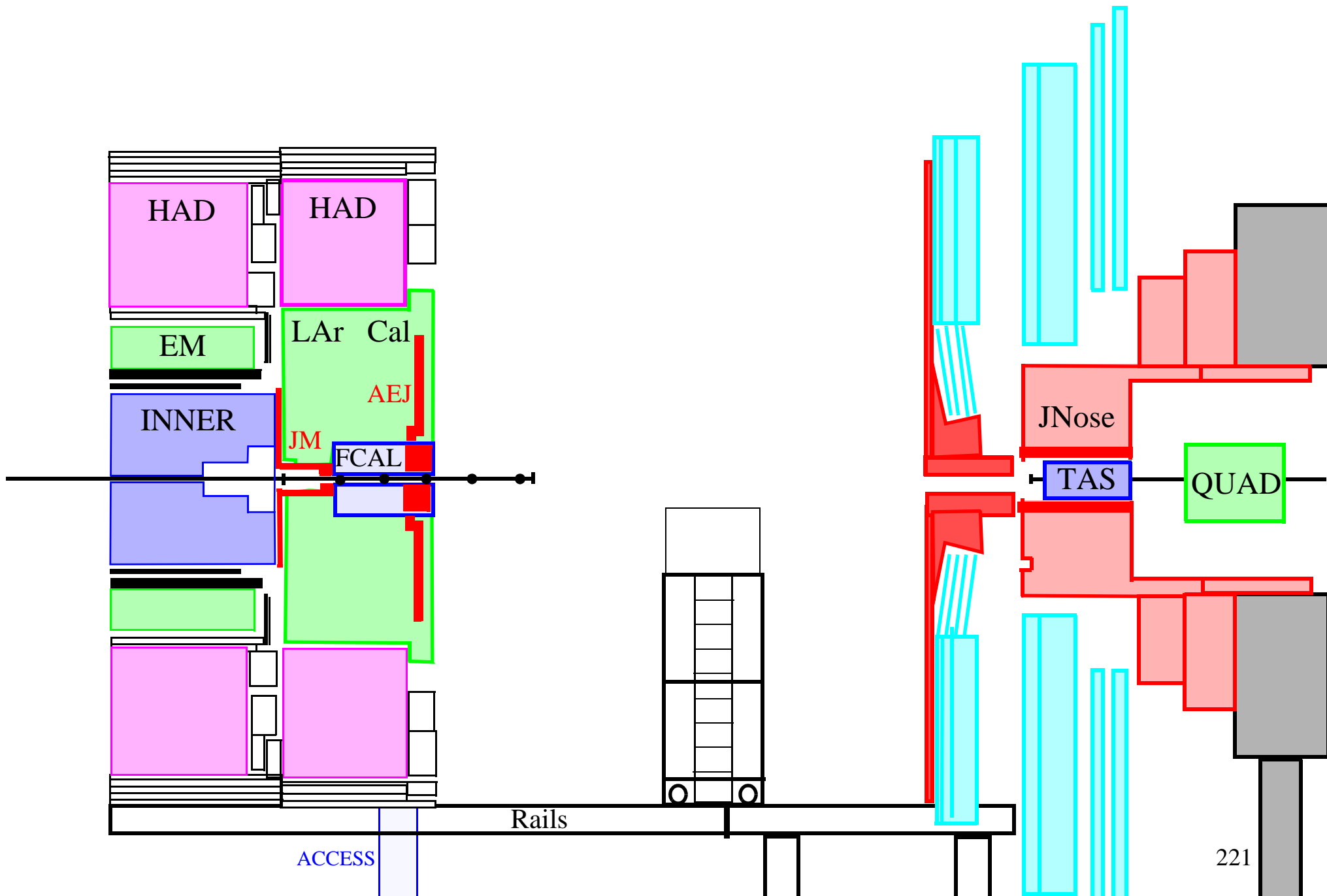

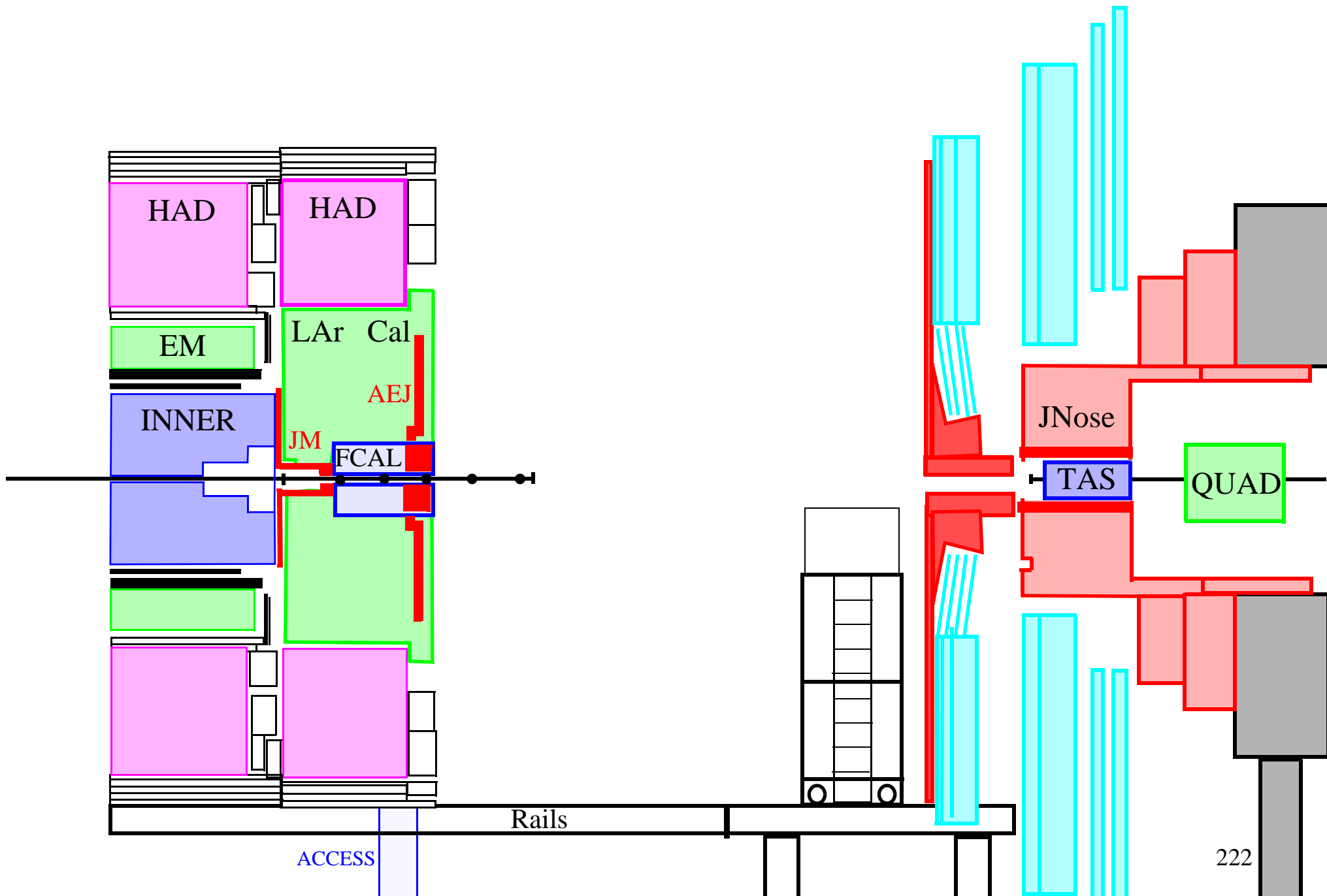

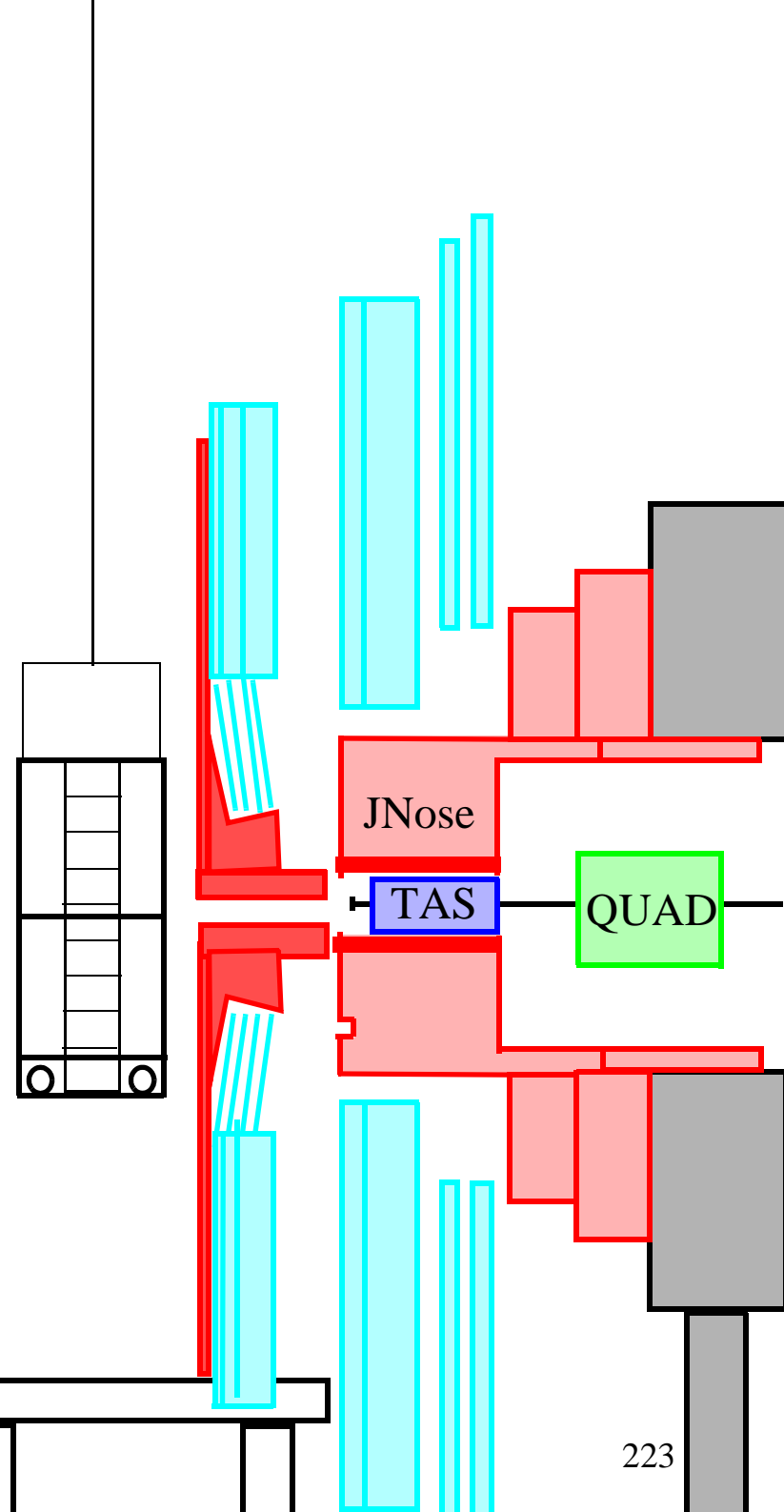
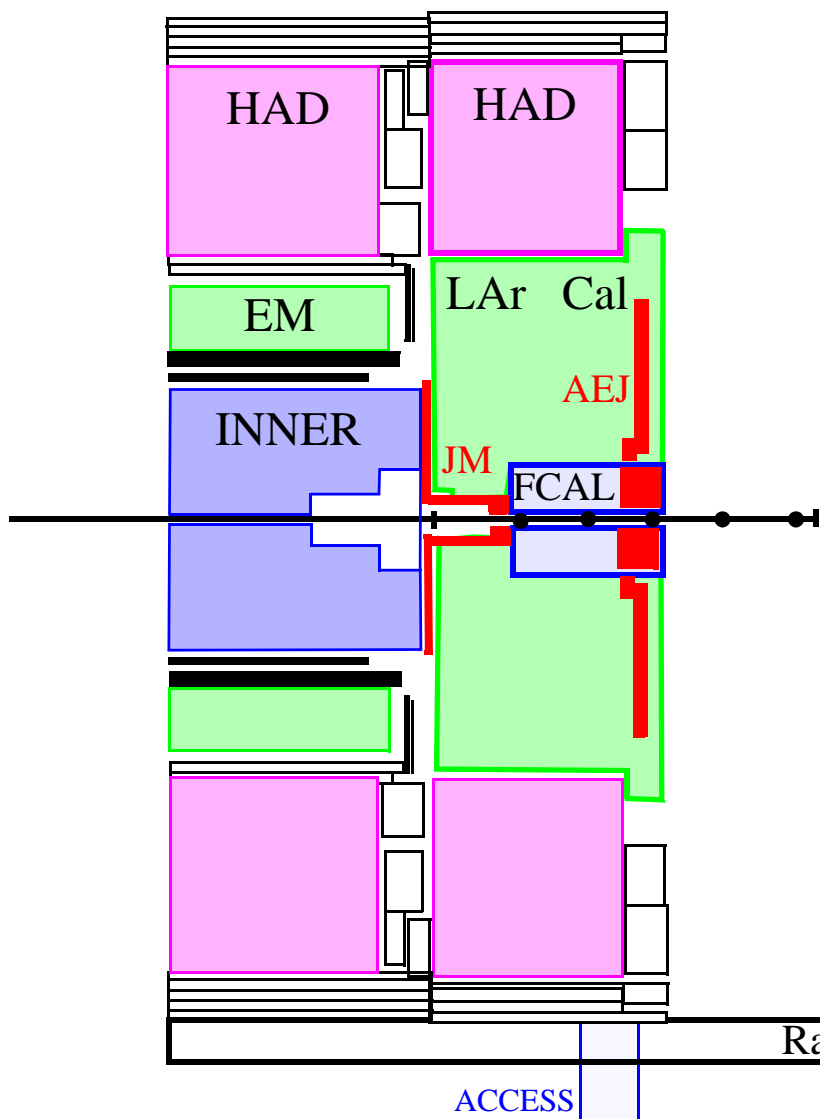

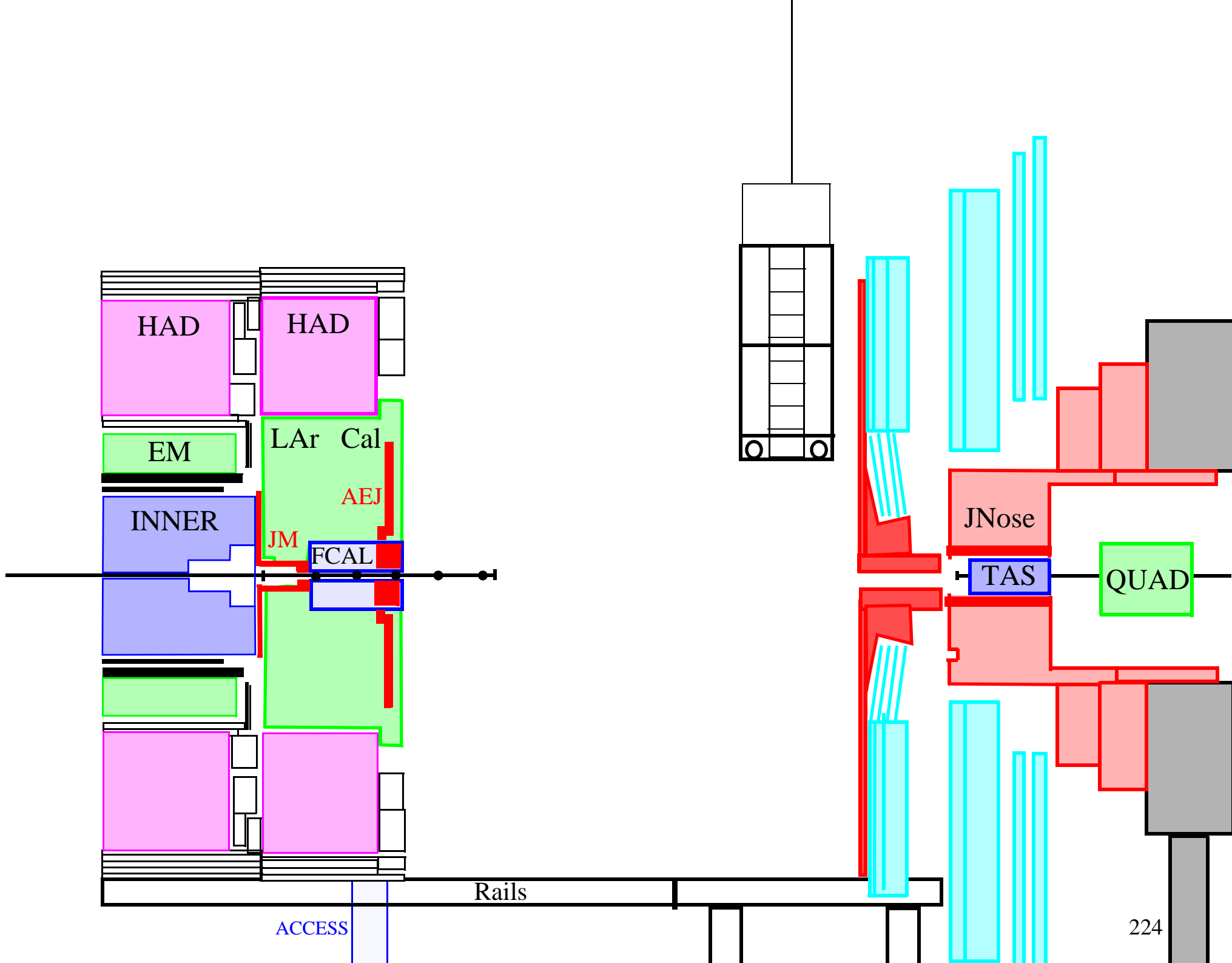

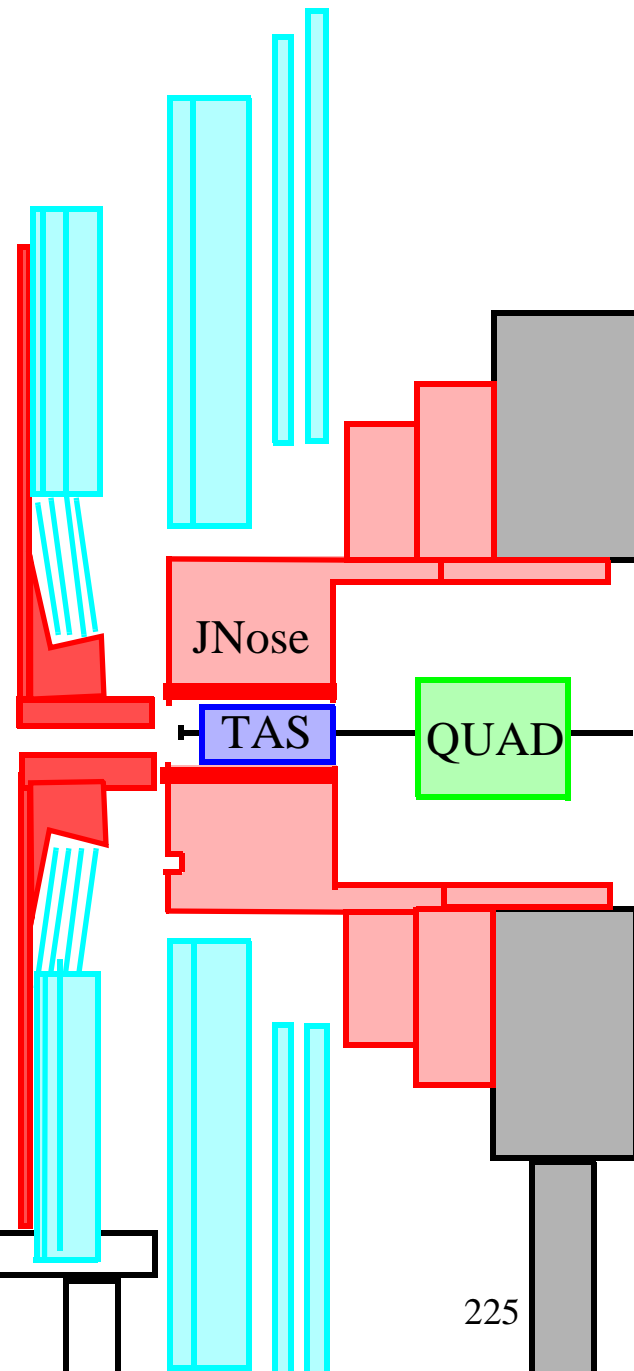
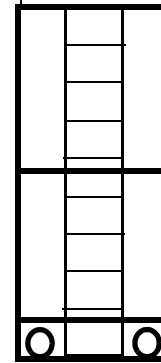
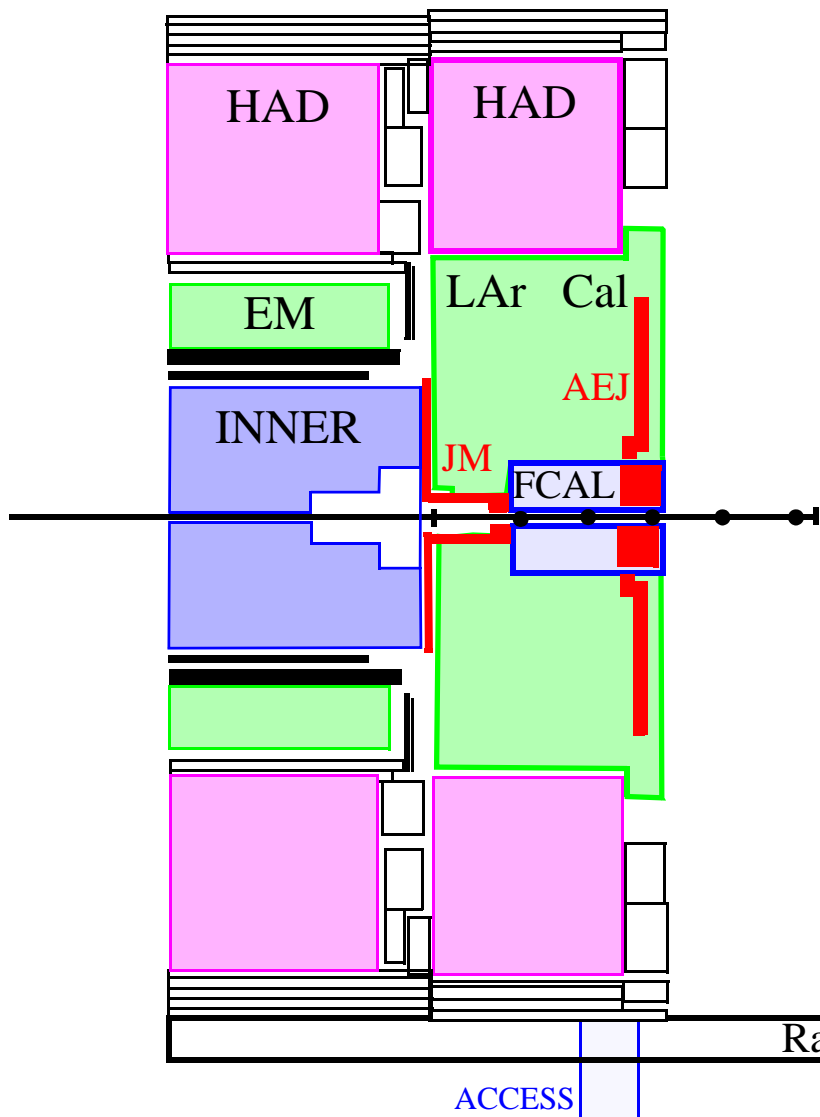

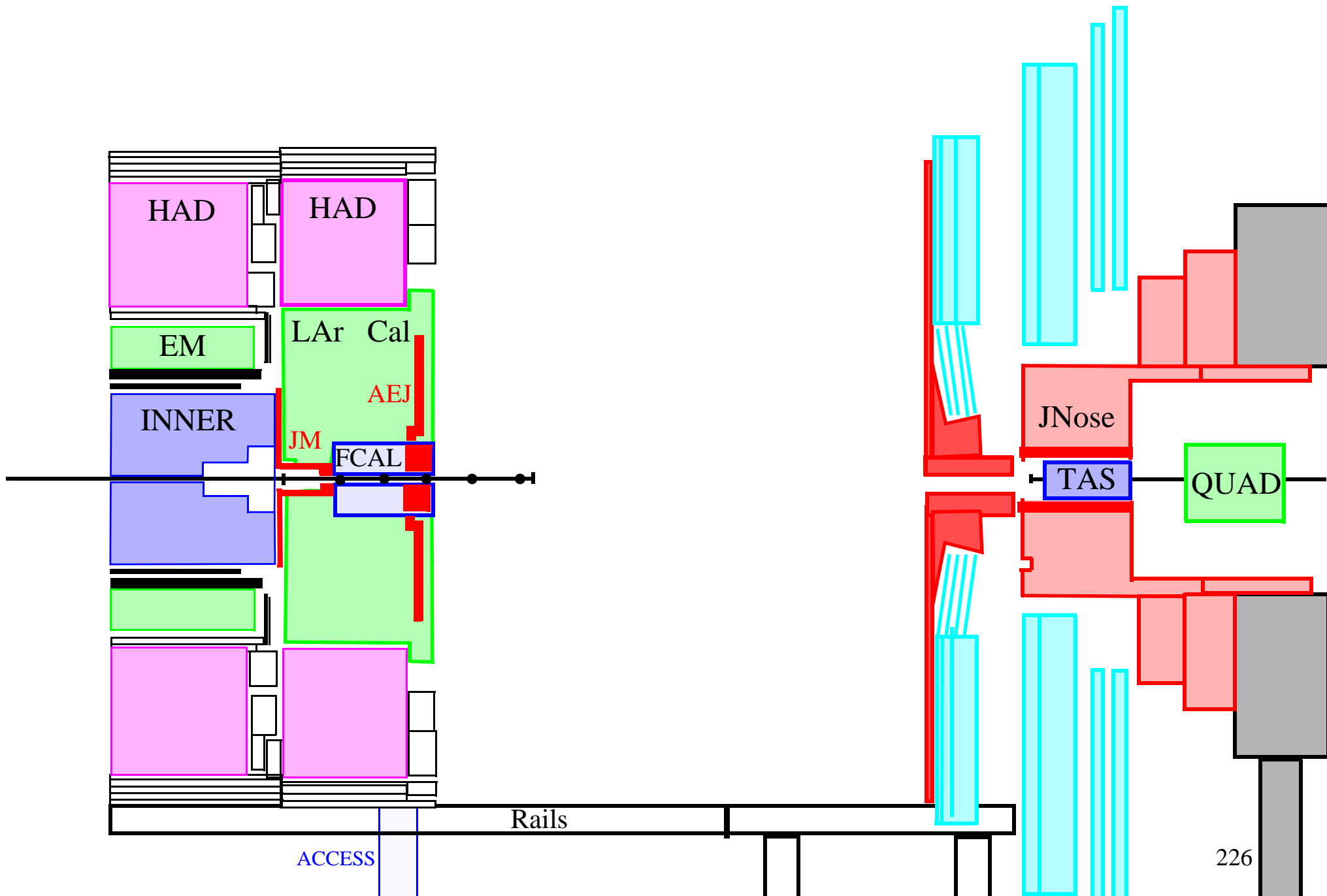

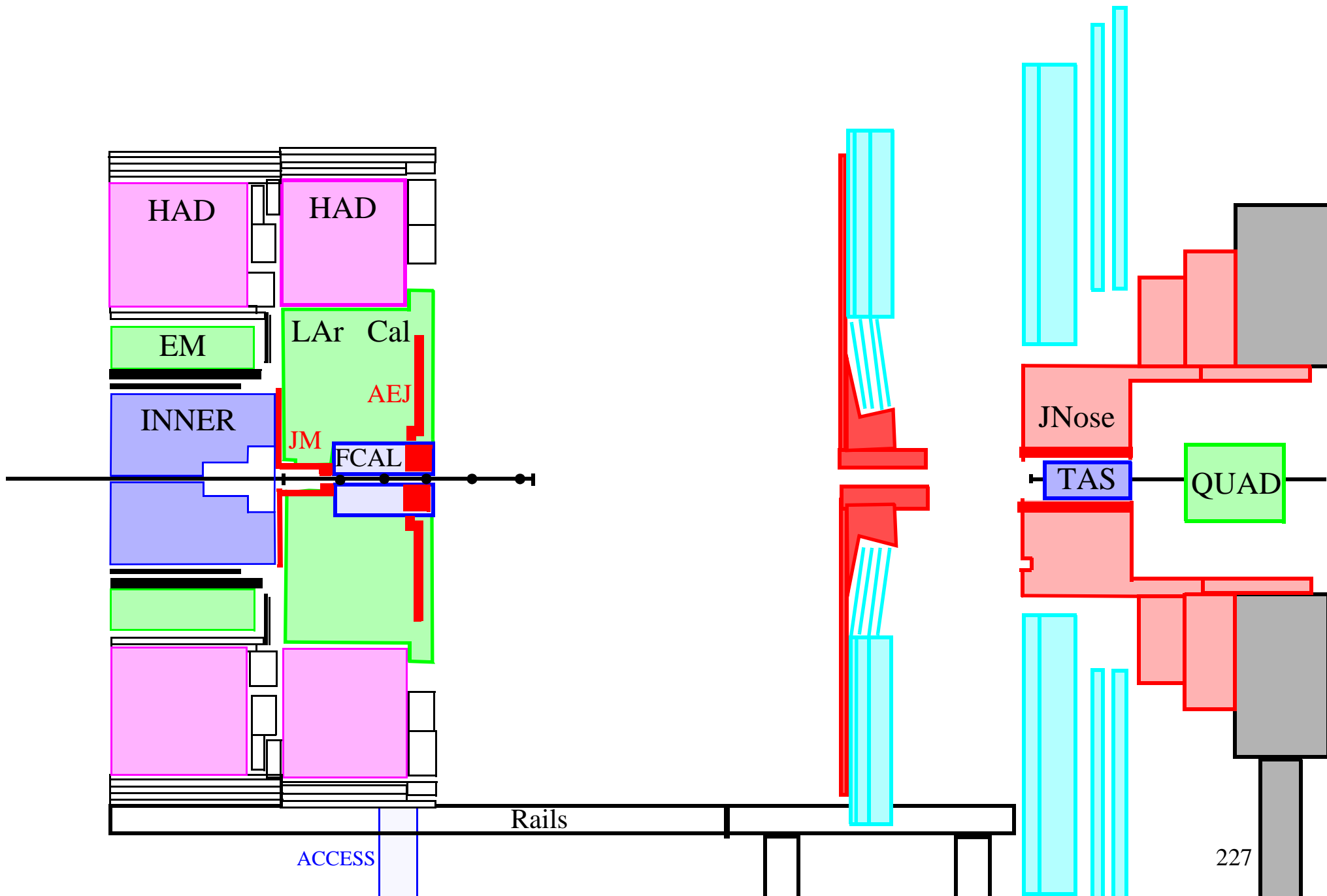

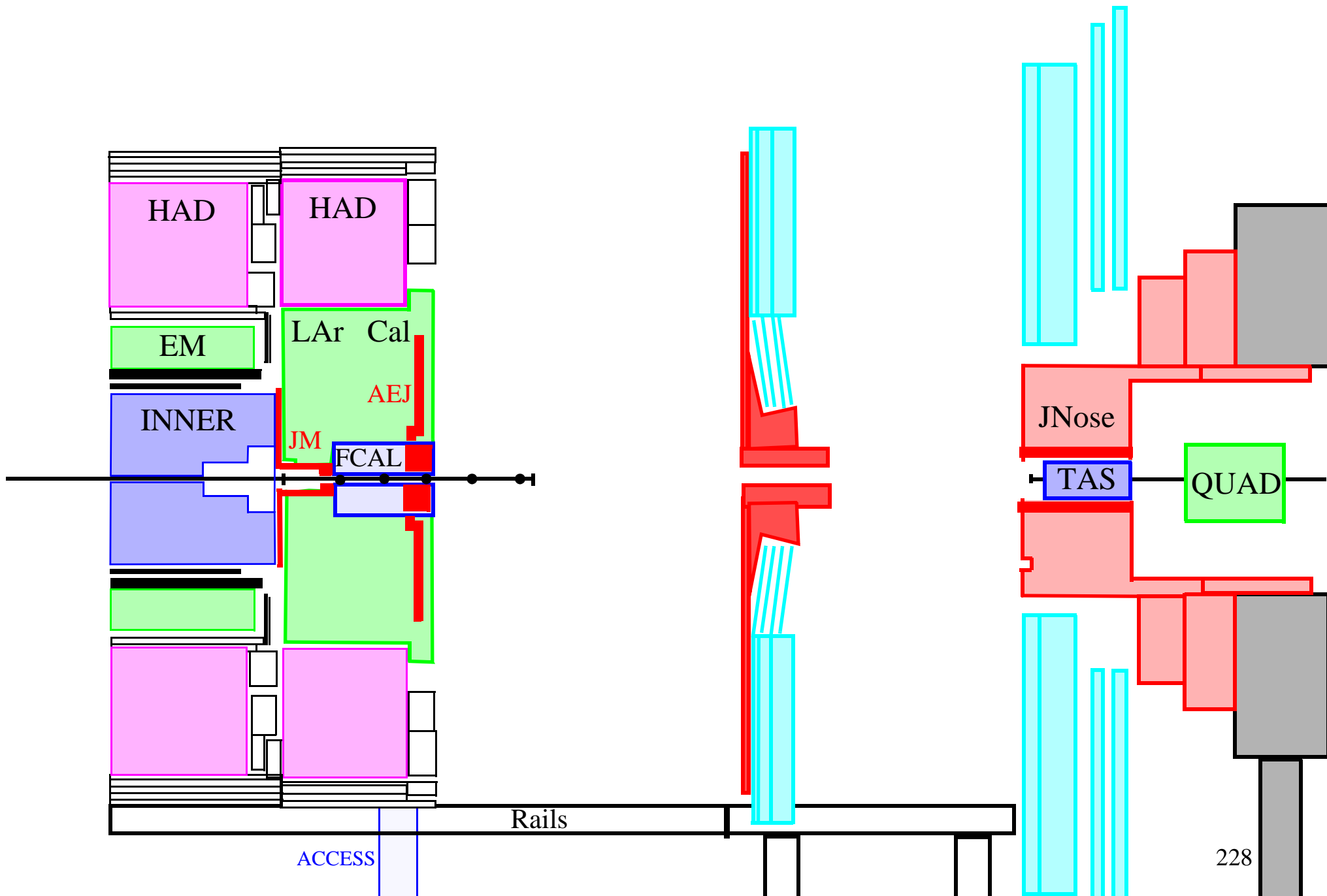

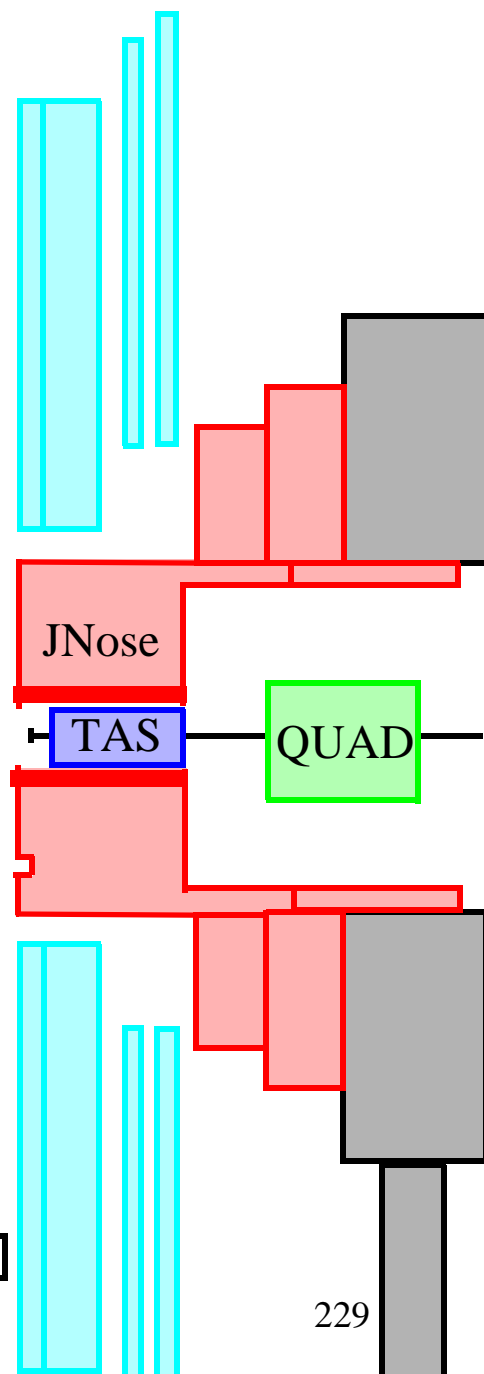
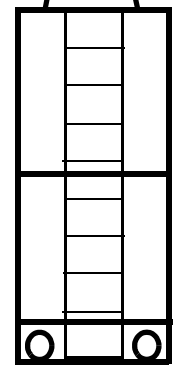
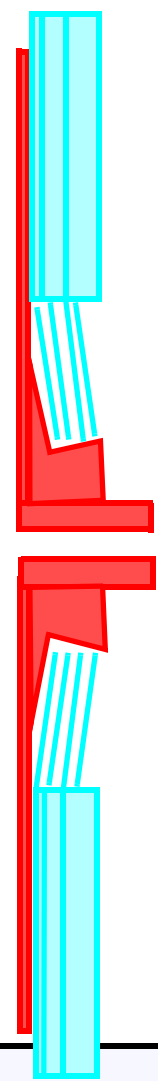
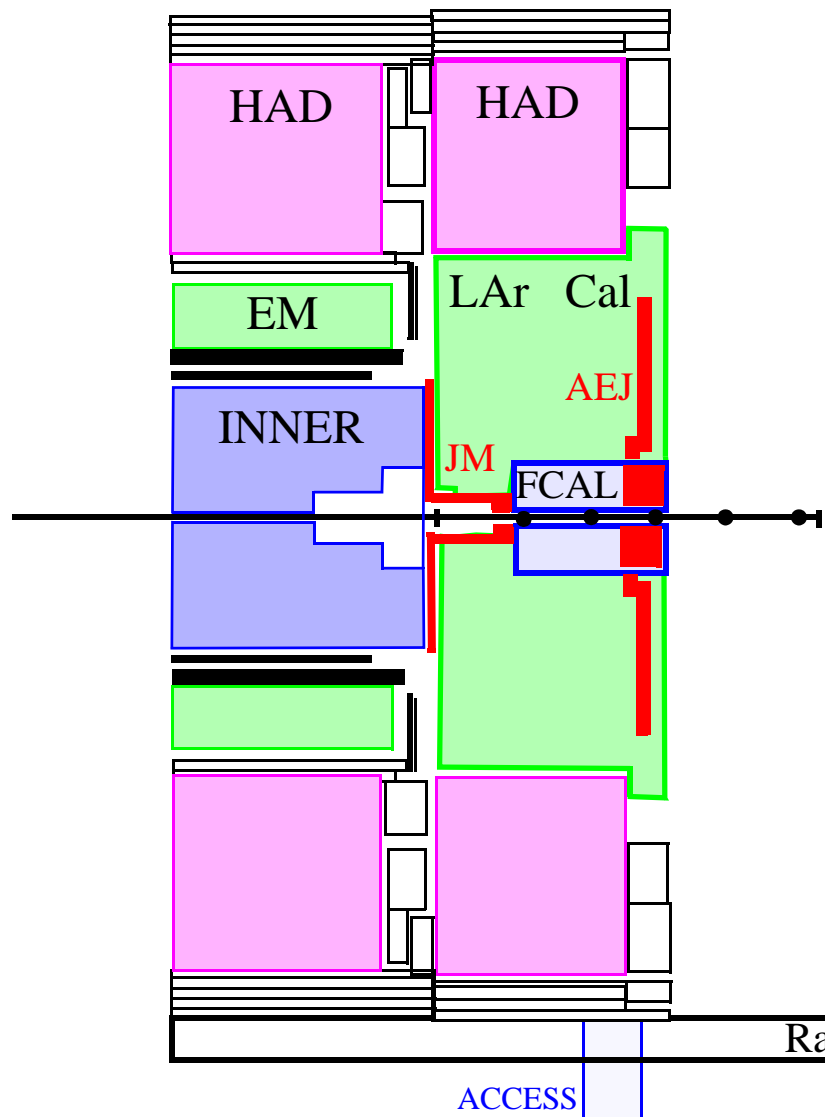

Rails

ACCESS

ACCESS

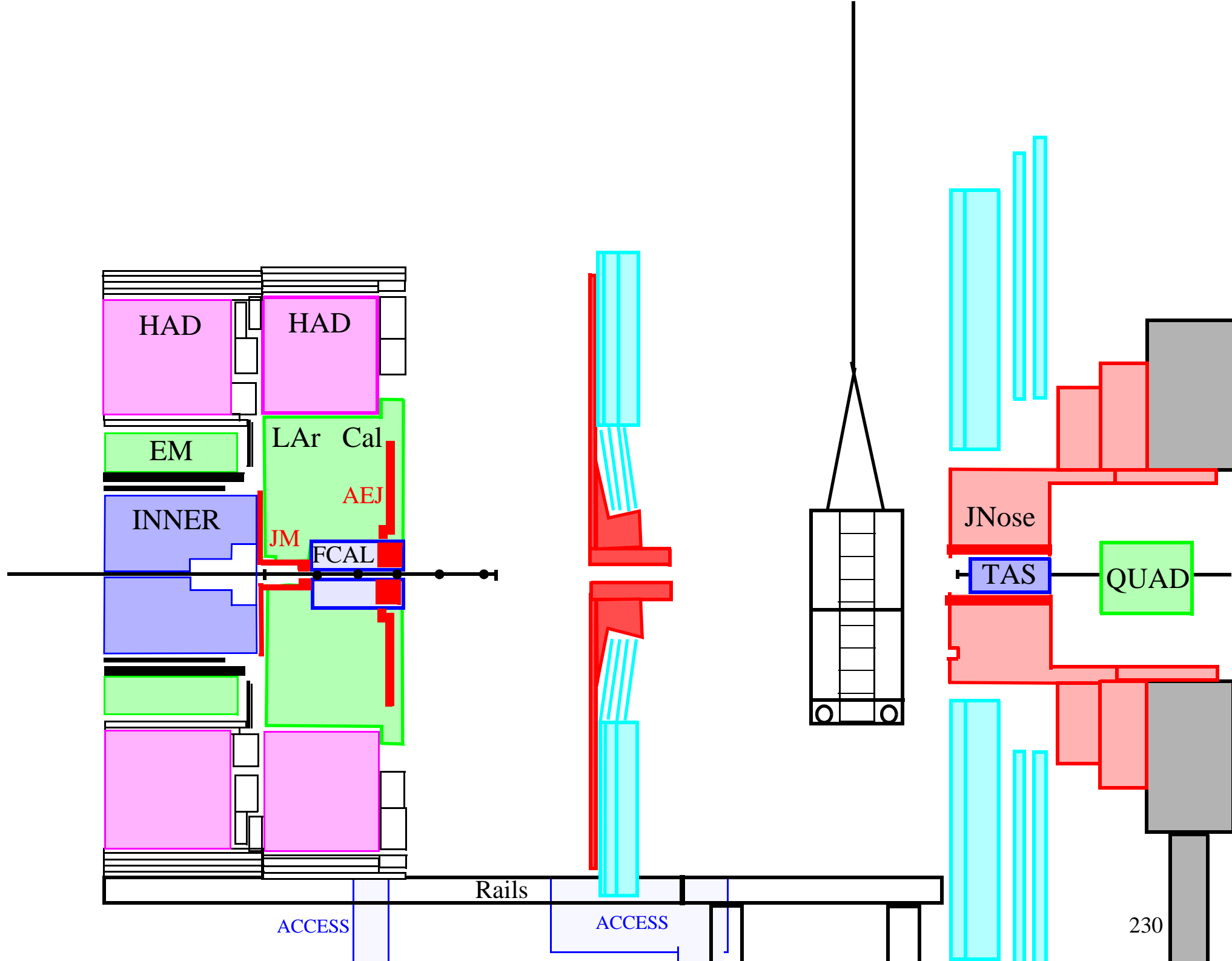

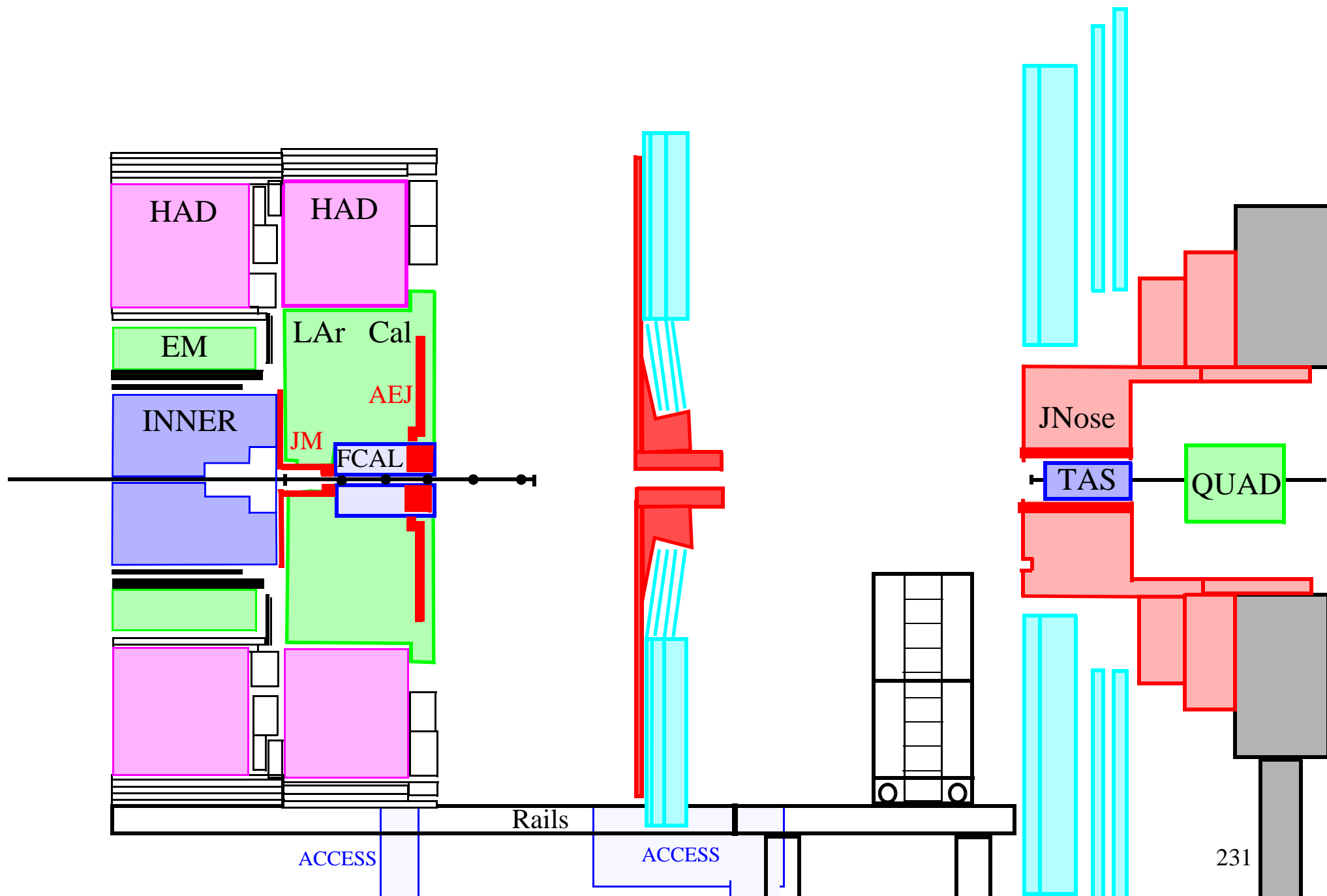

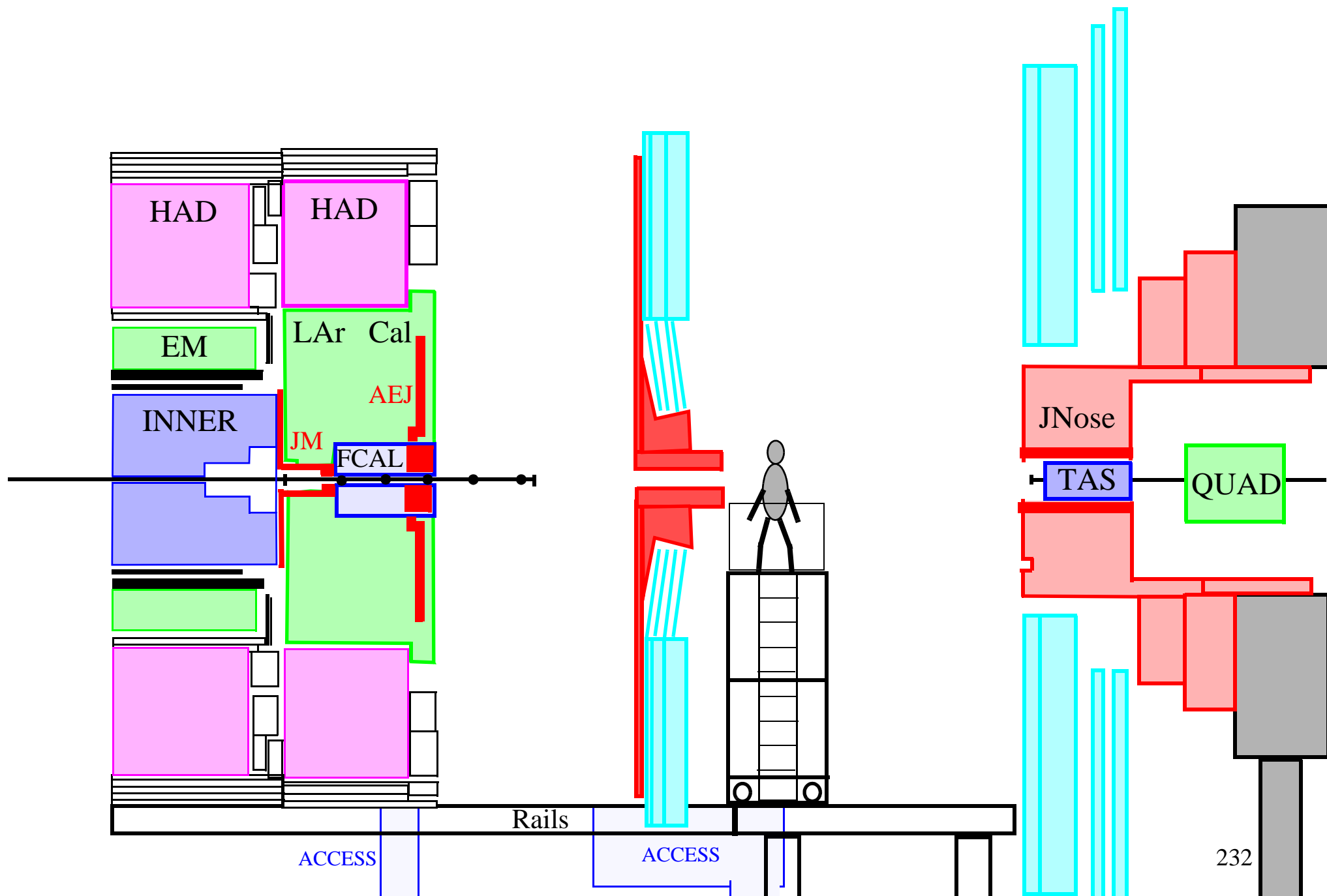

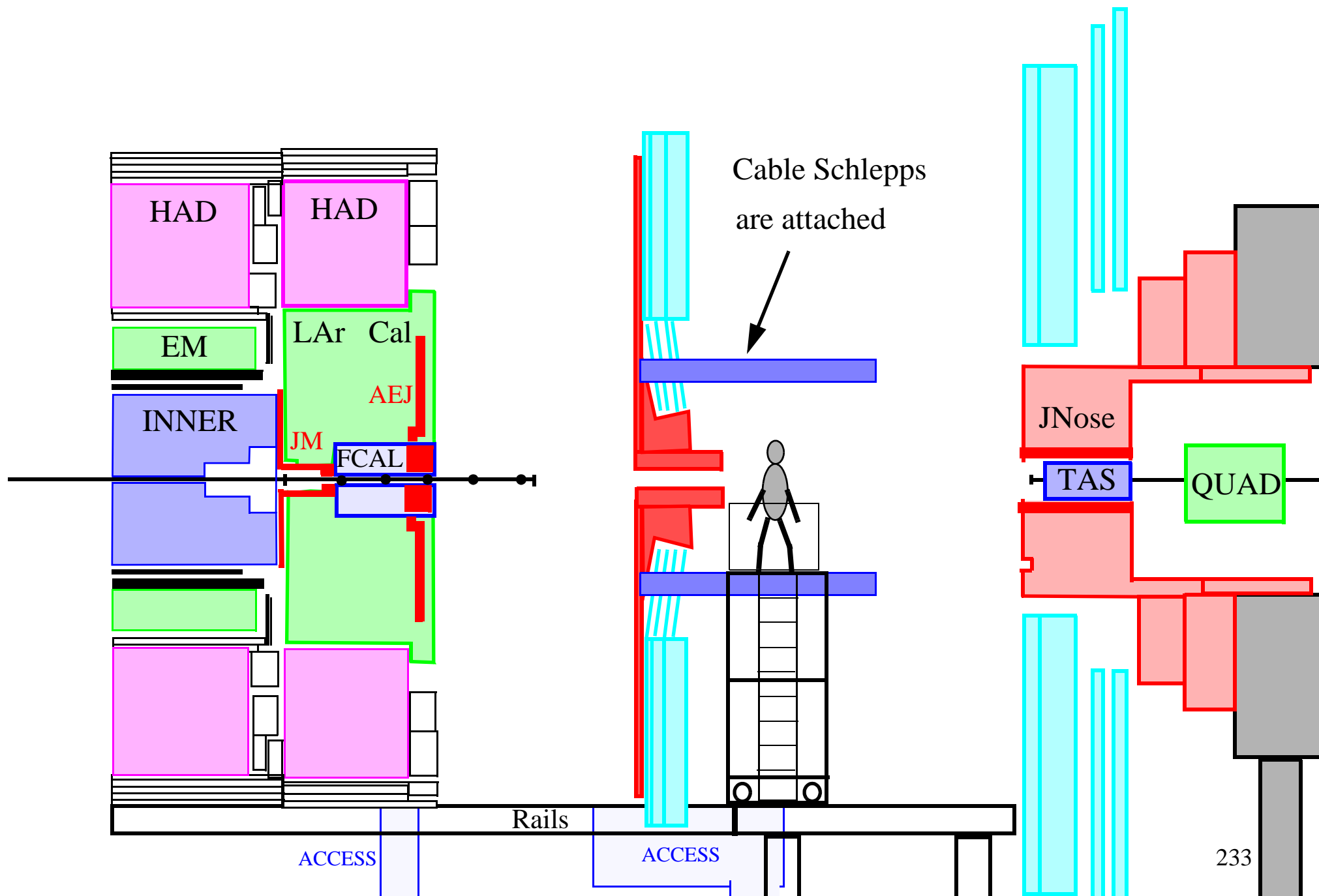

SERVICES TRAYS

MDT ROUTING

Cable Schlepps

CSC ROUTING

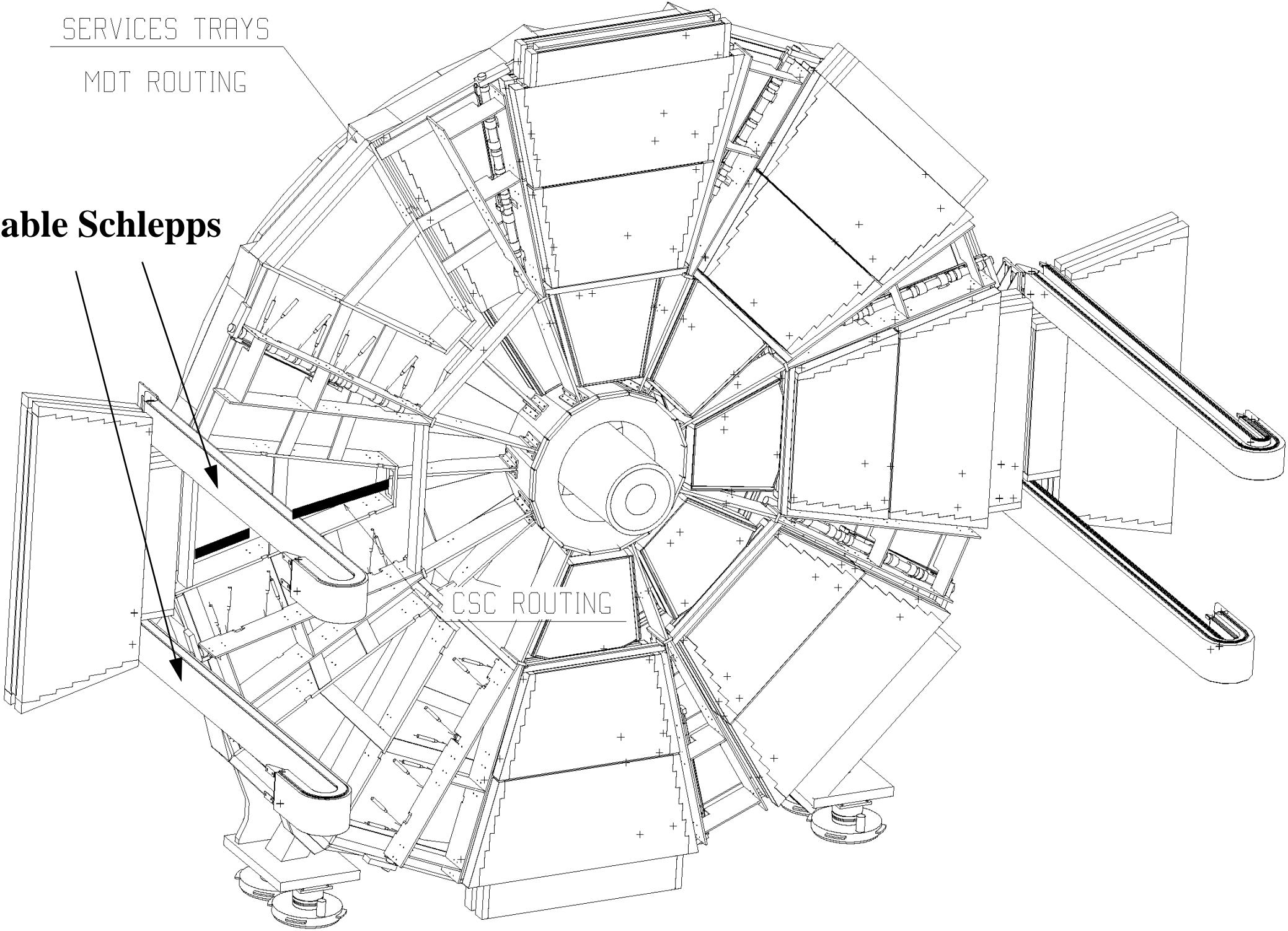

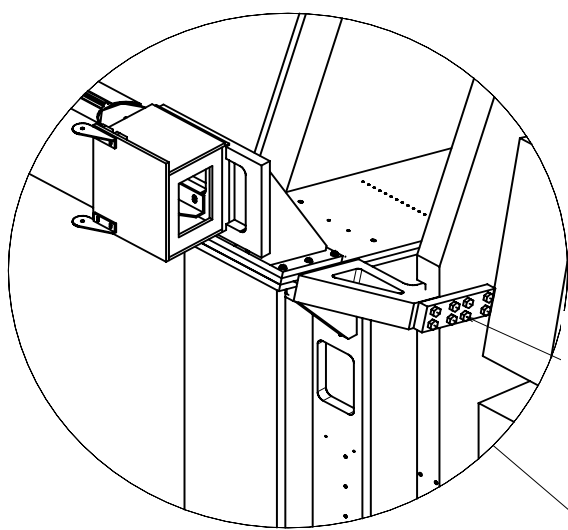

3 attachments
to the SW

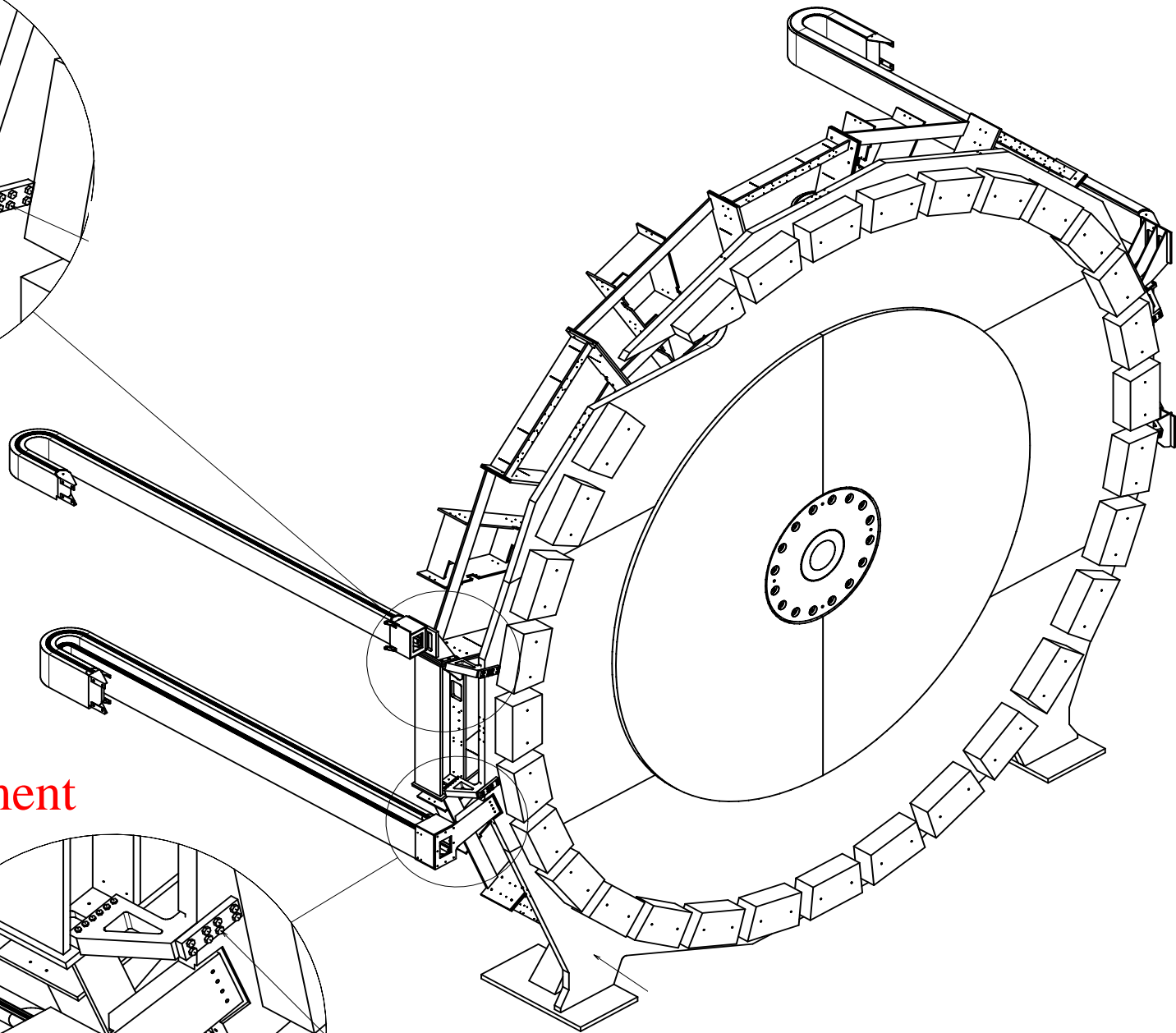

One attachment
to the JD.

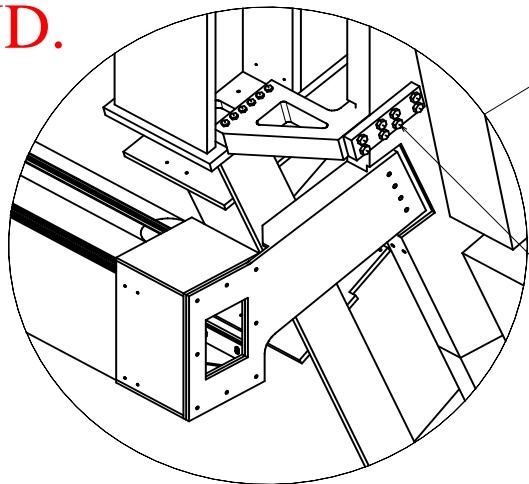

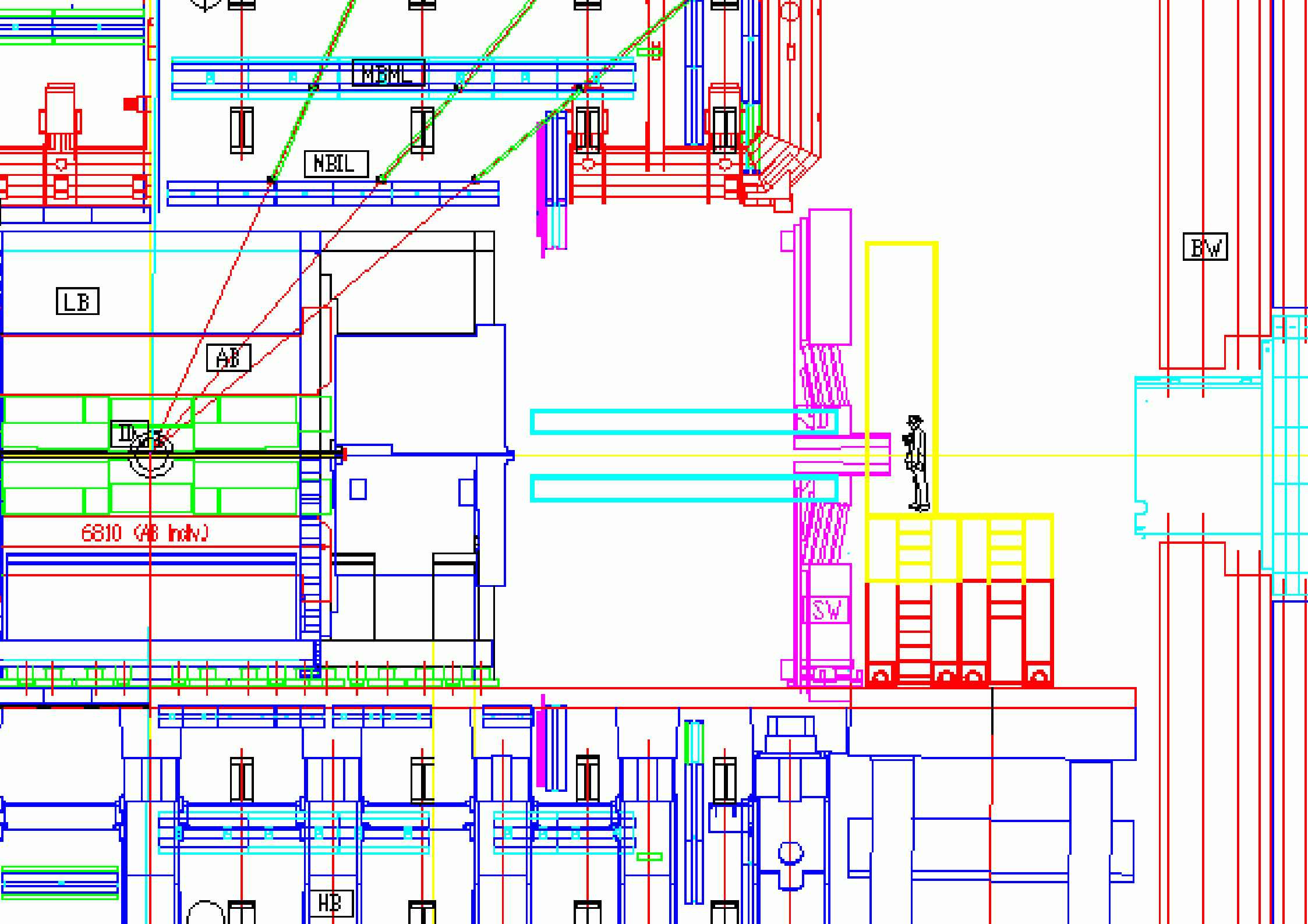

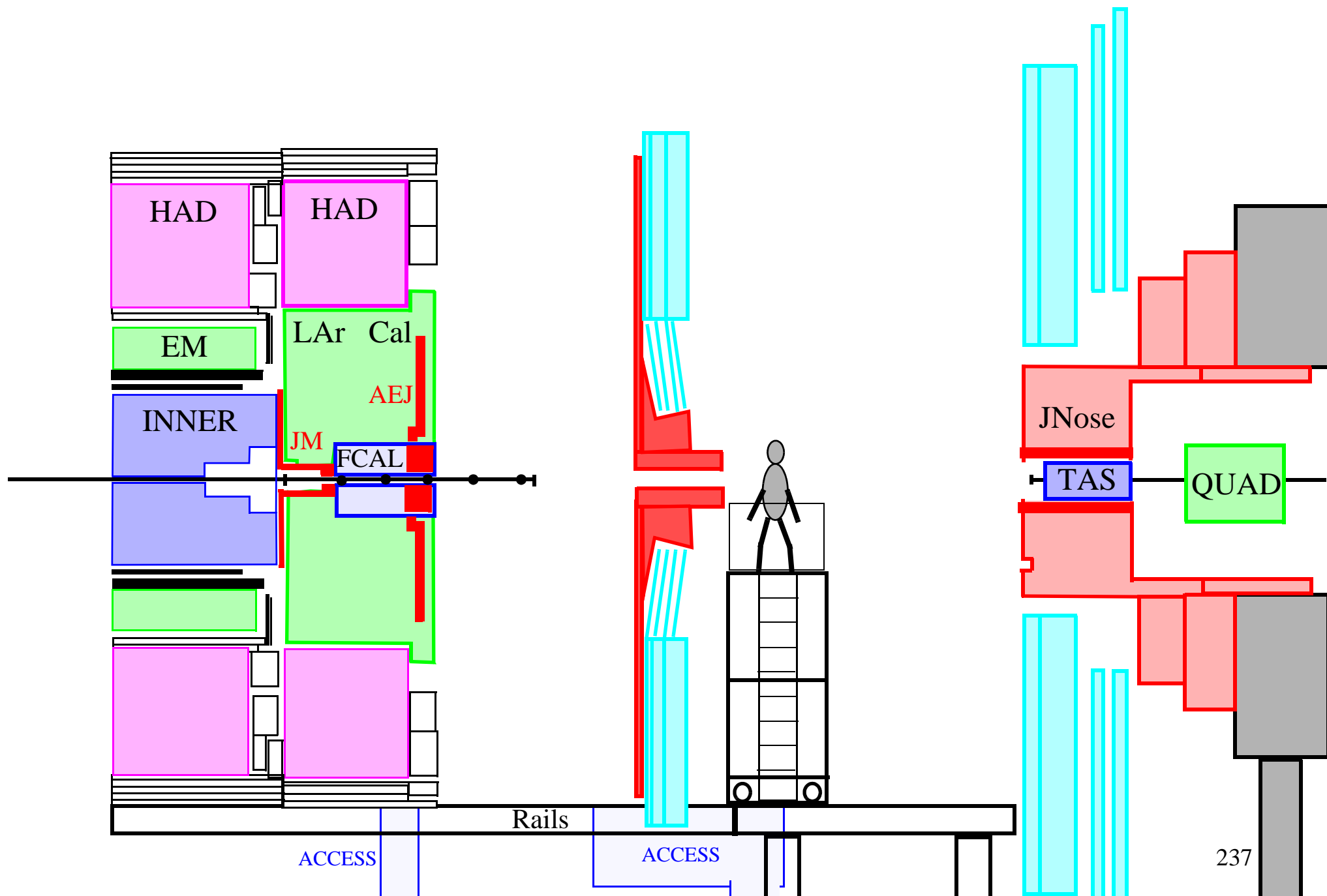

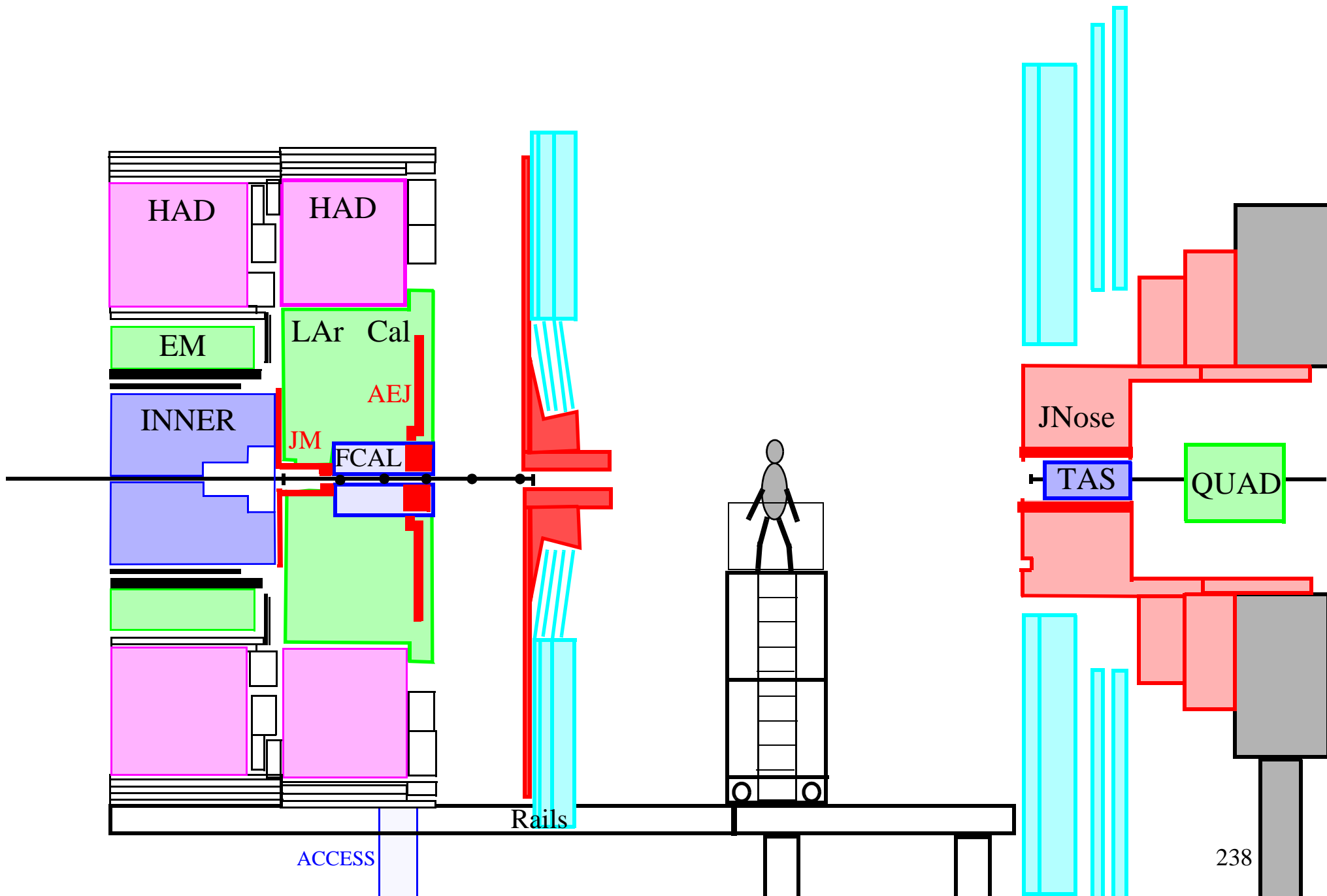

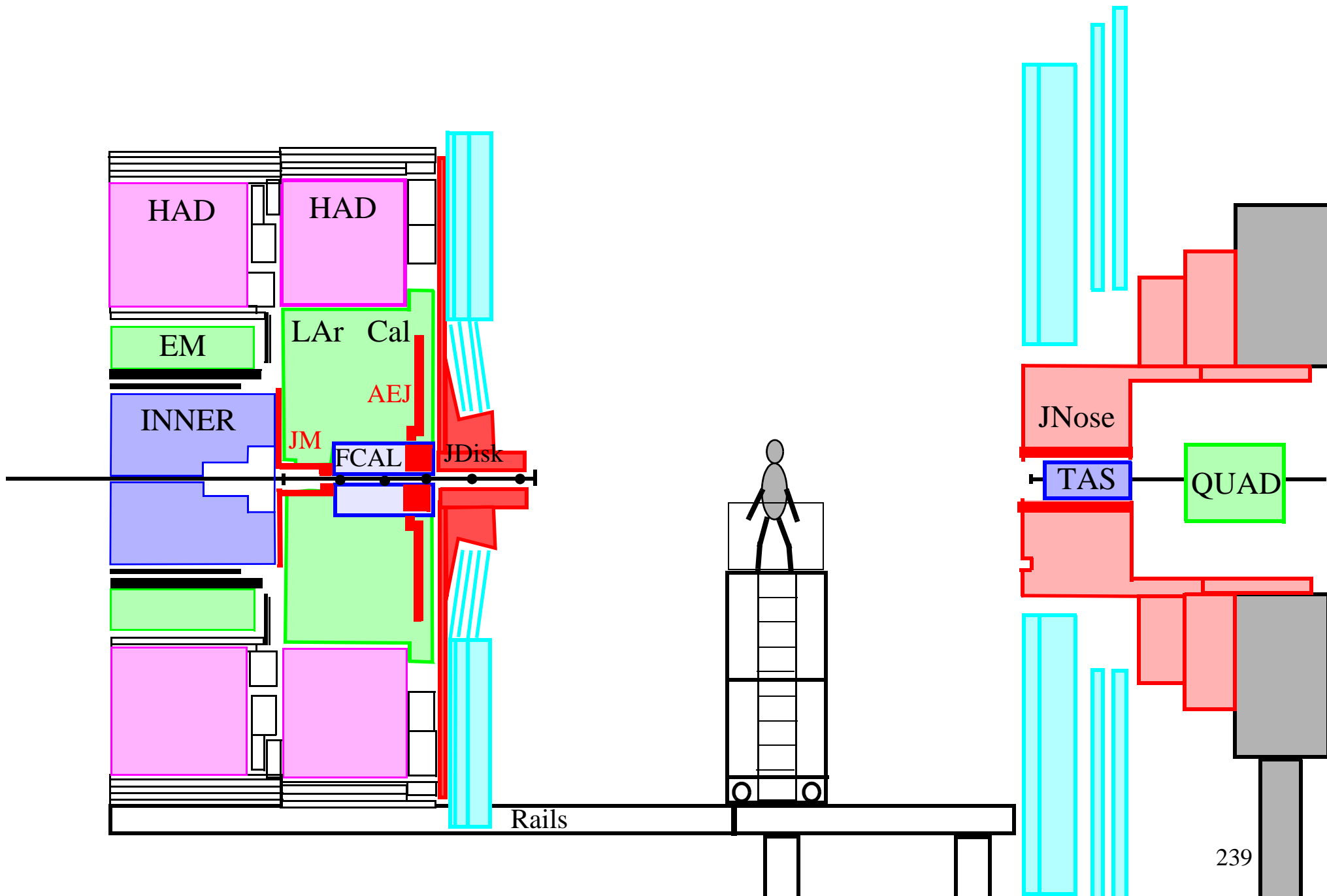

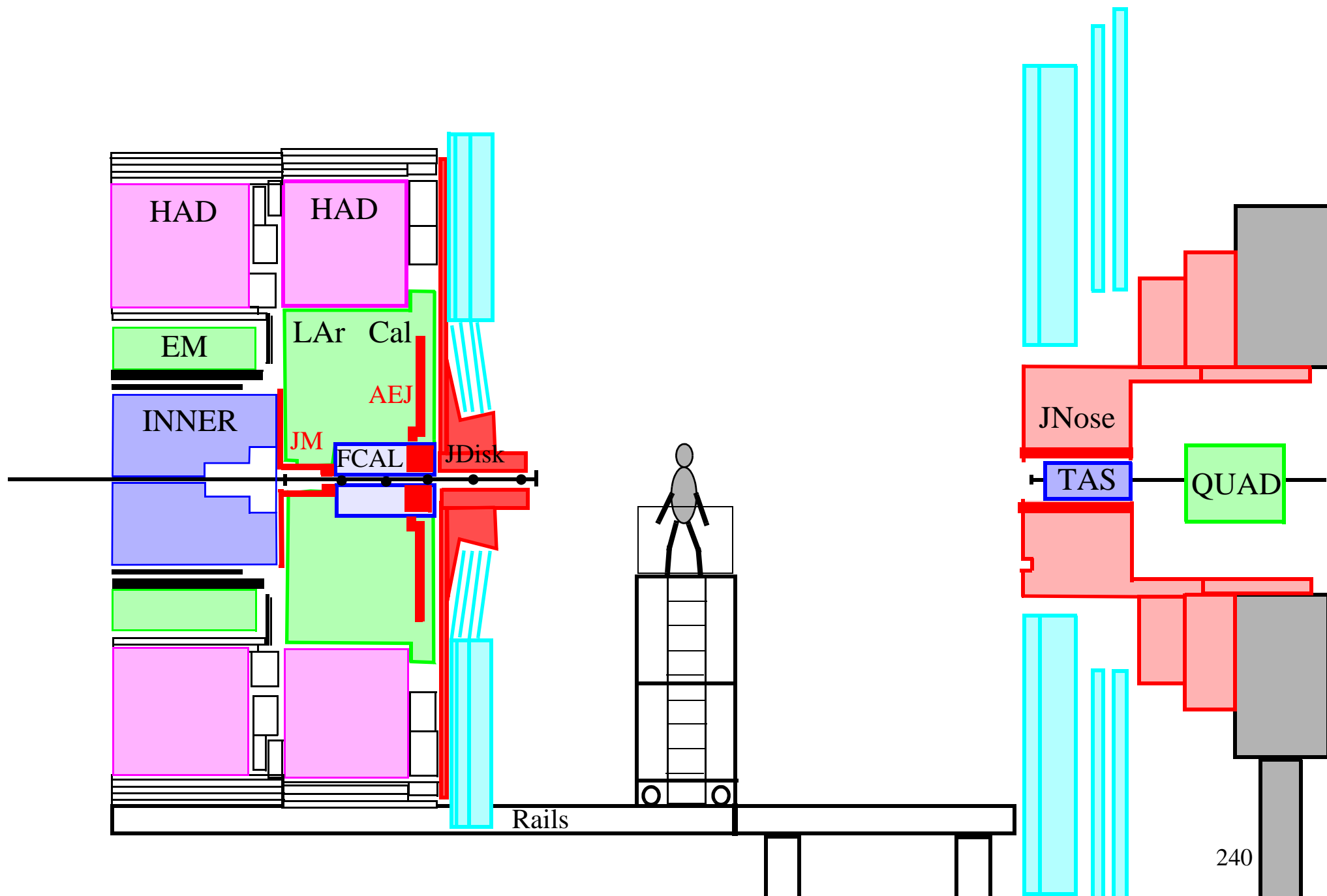

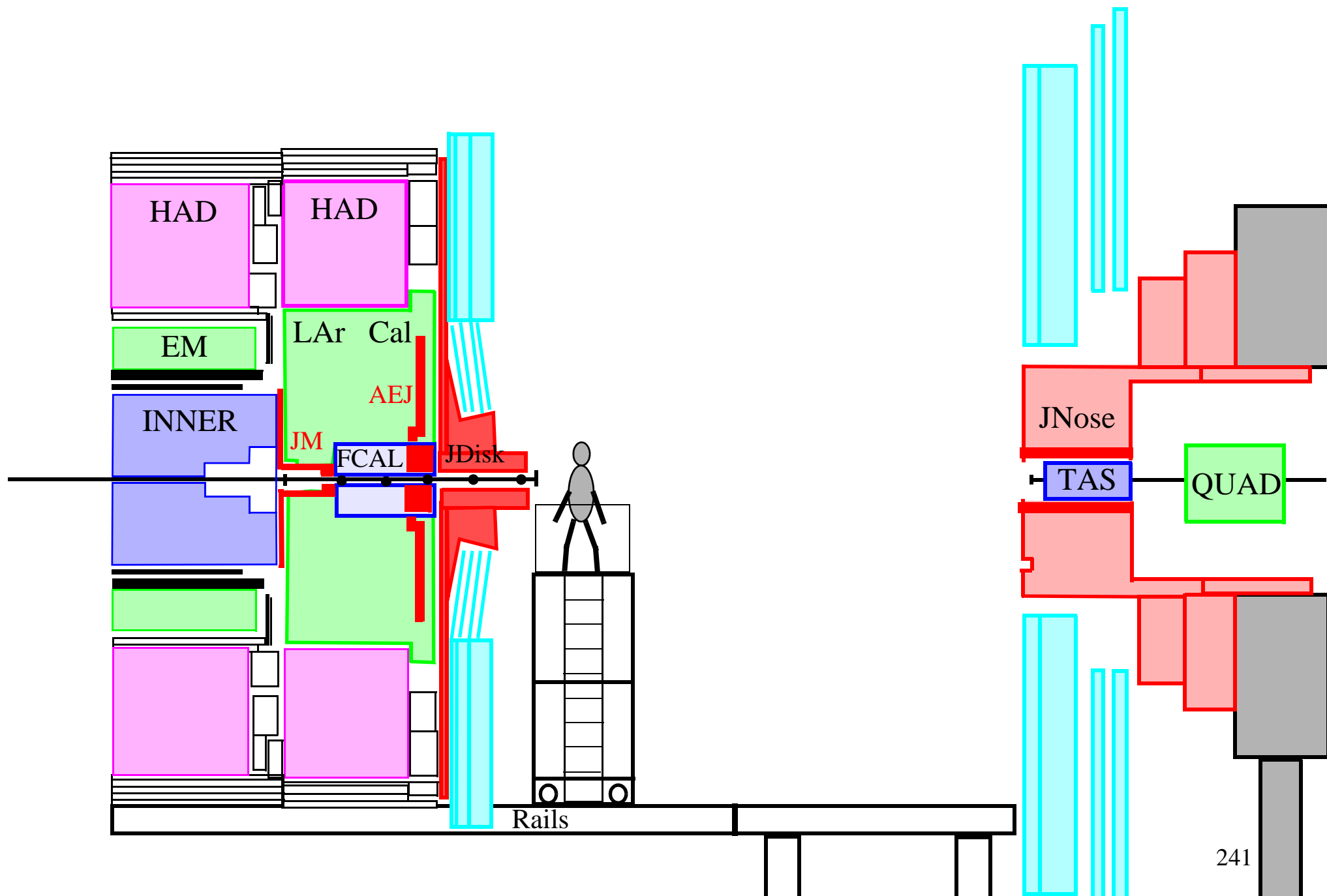

Beampipe supports

This support has to be attached.

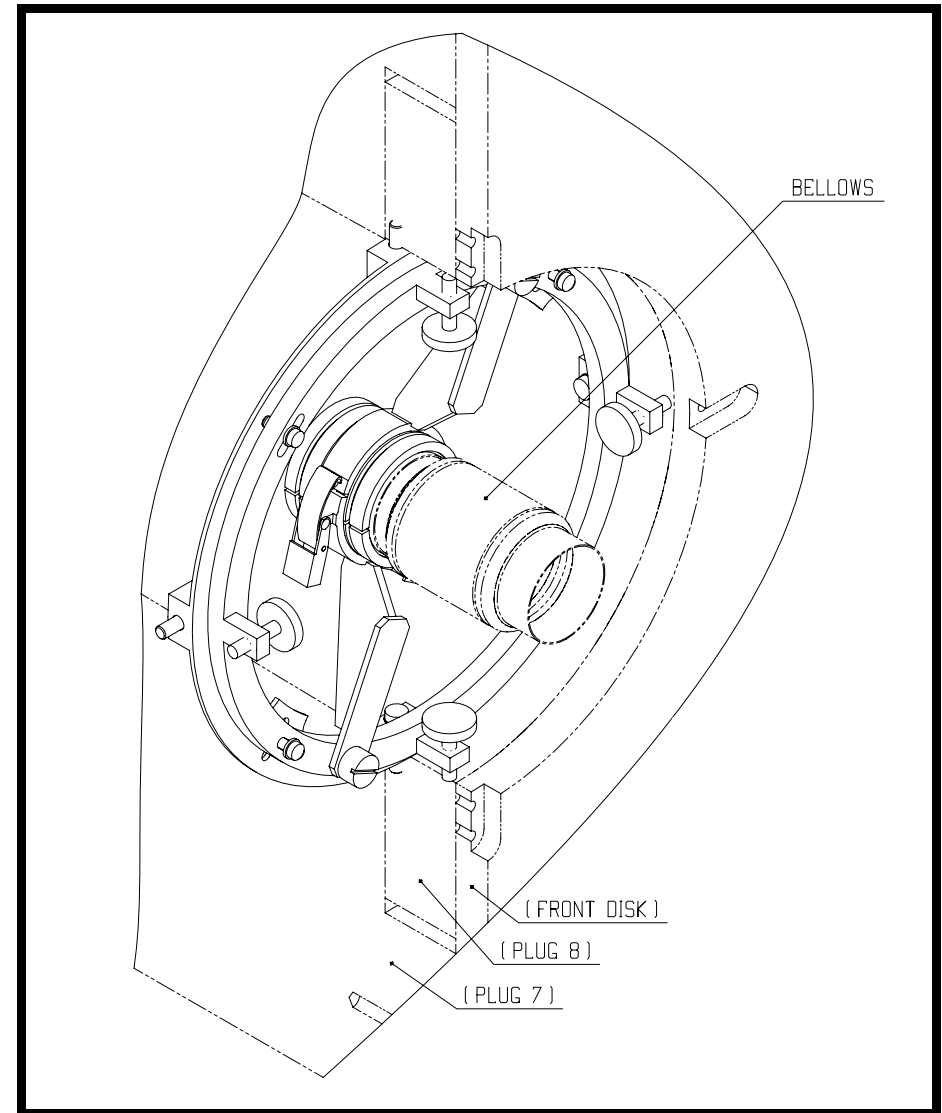
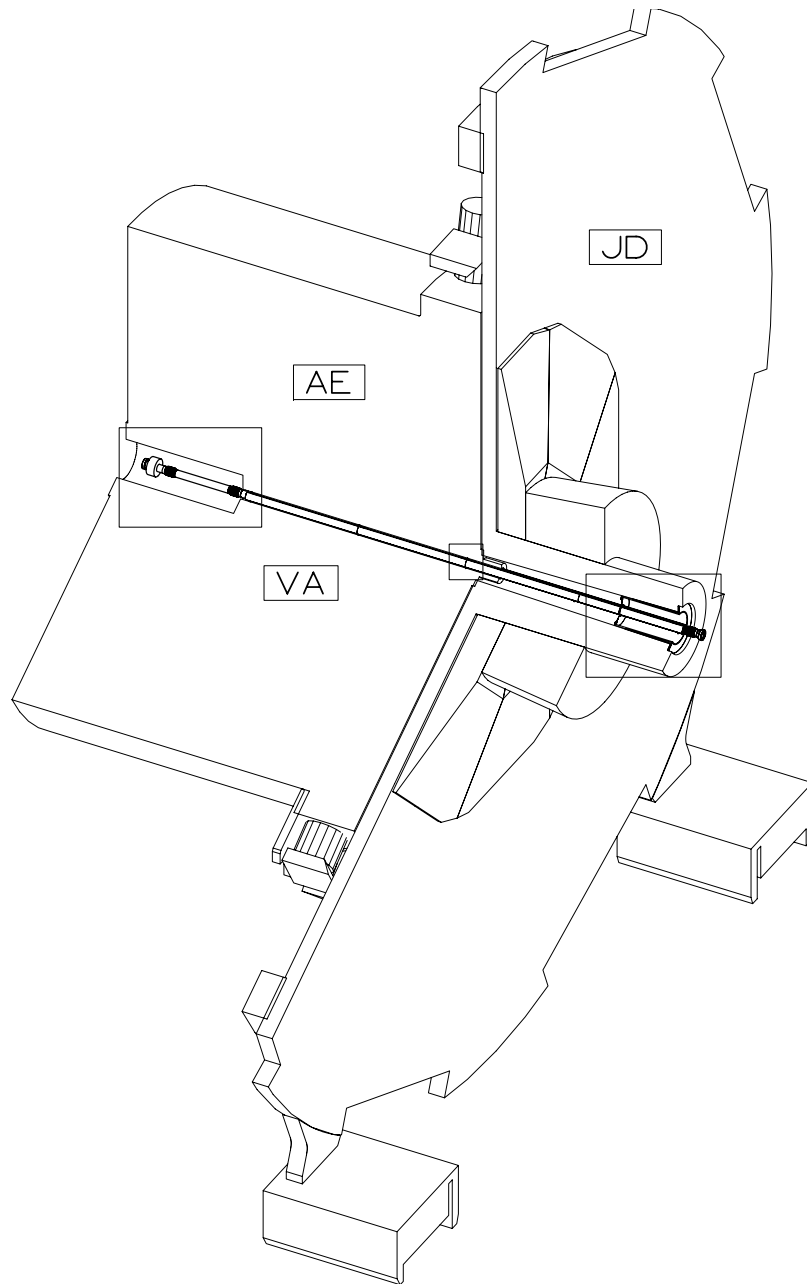

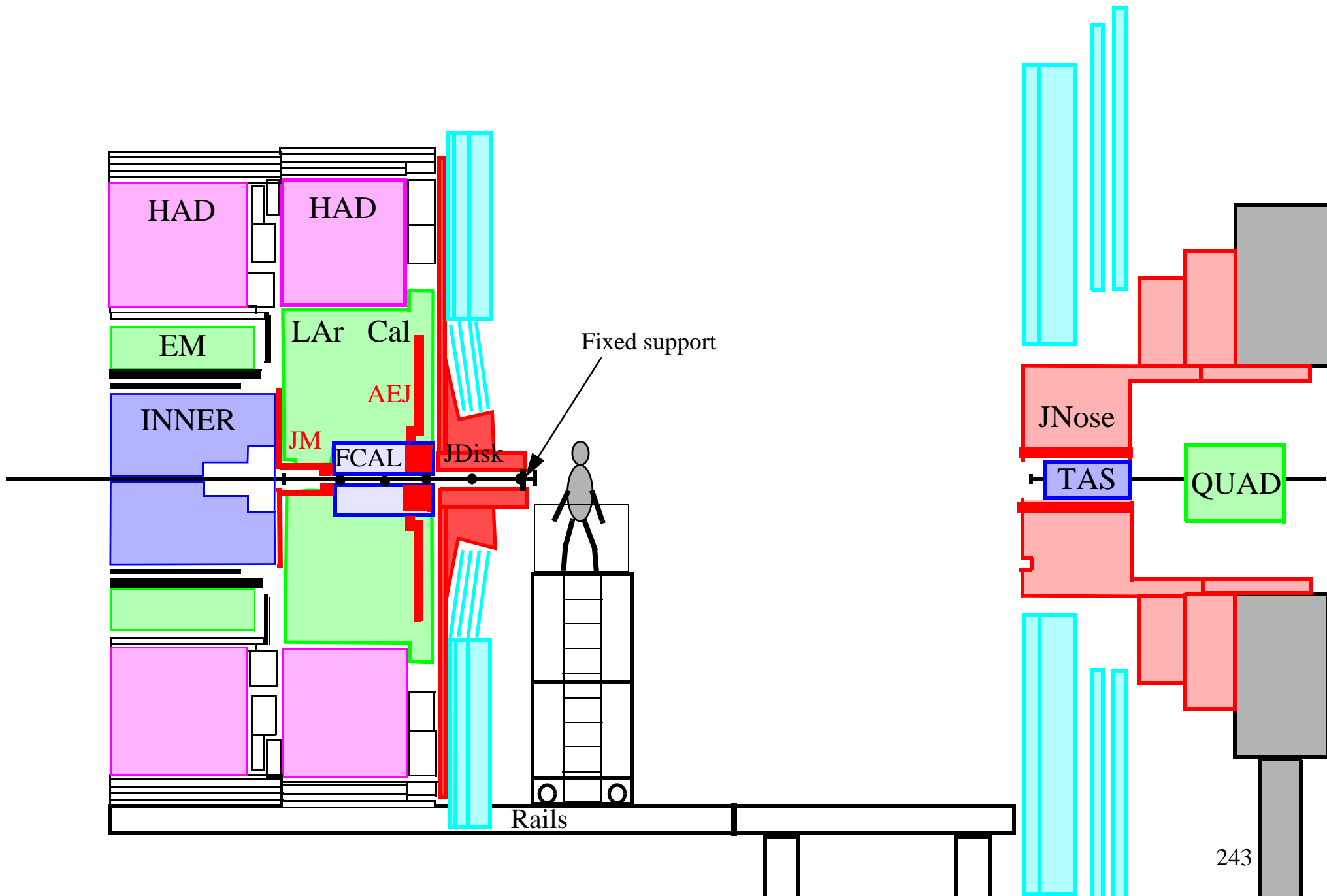

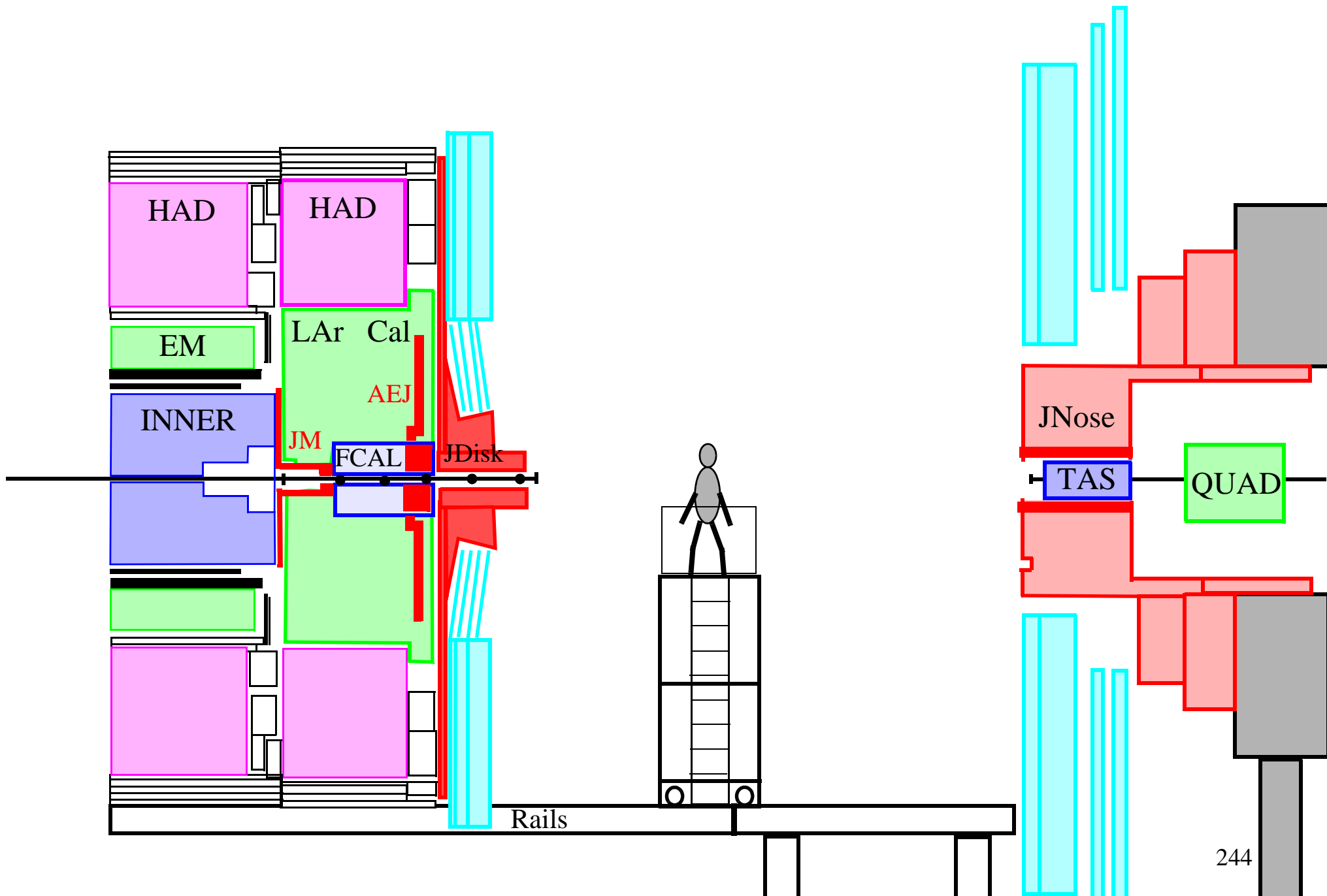

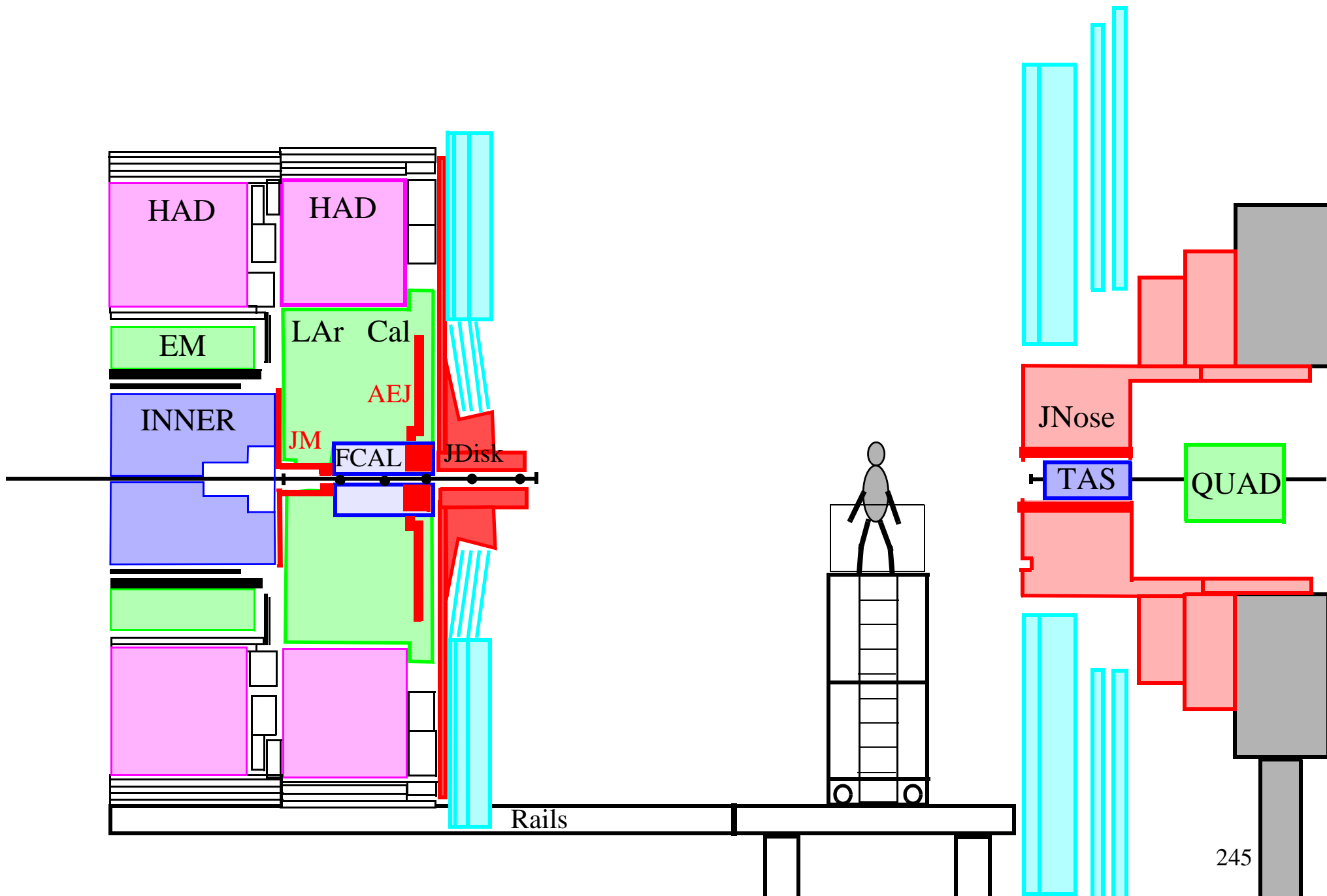

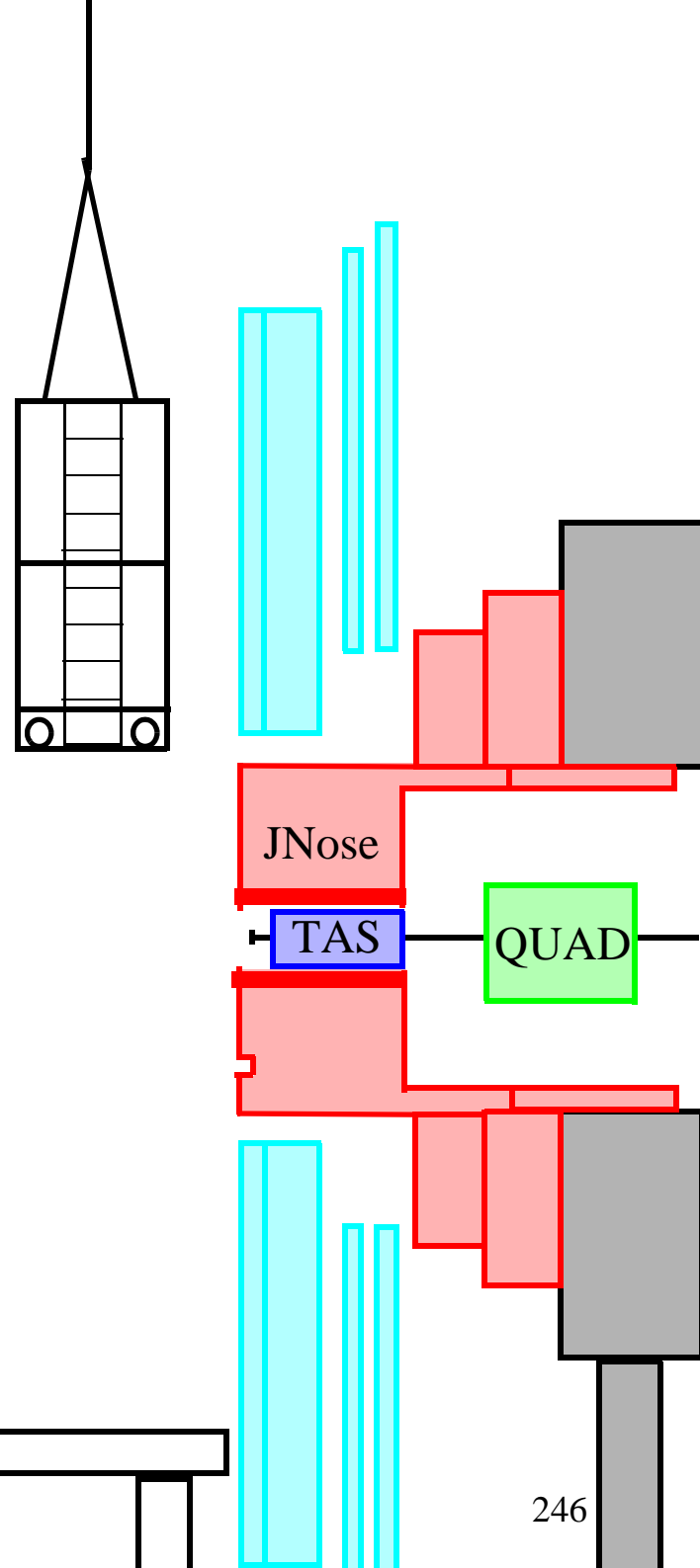
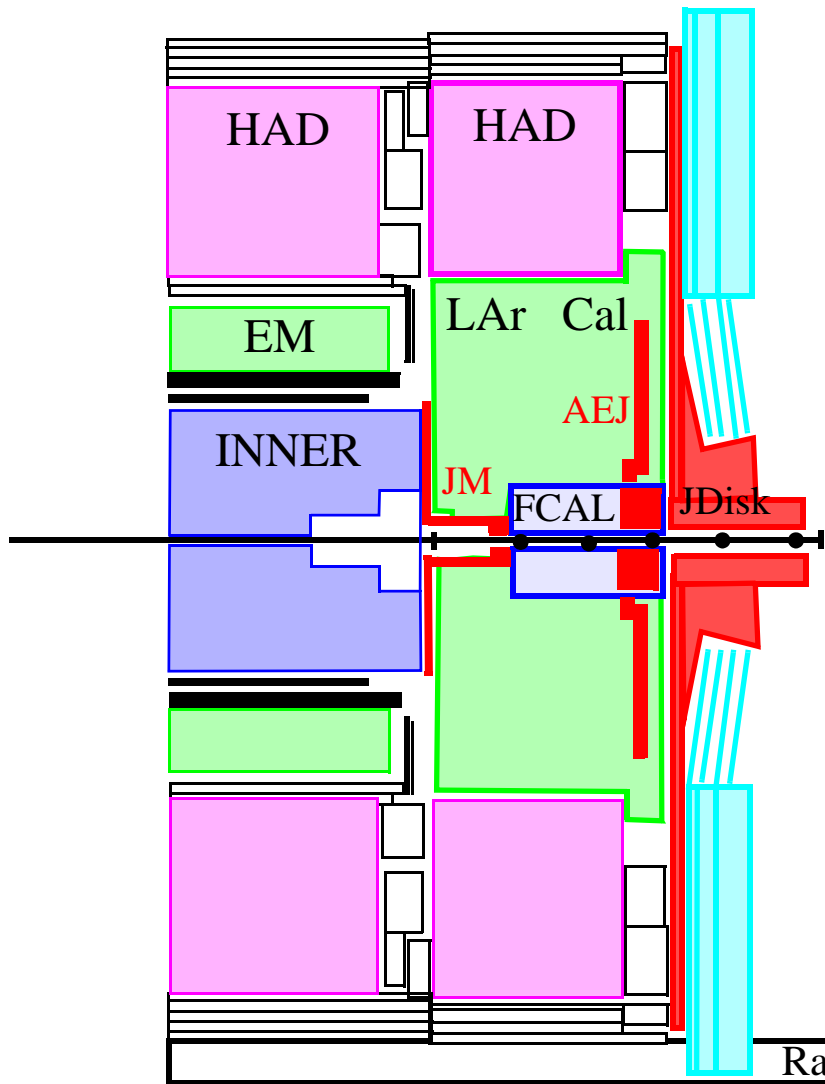

May 2007

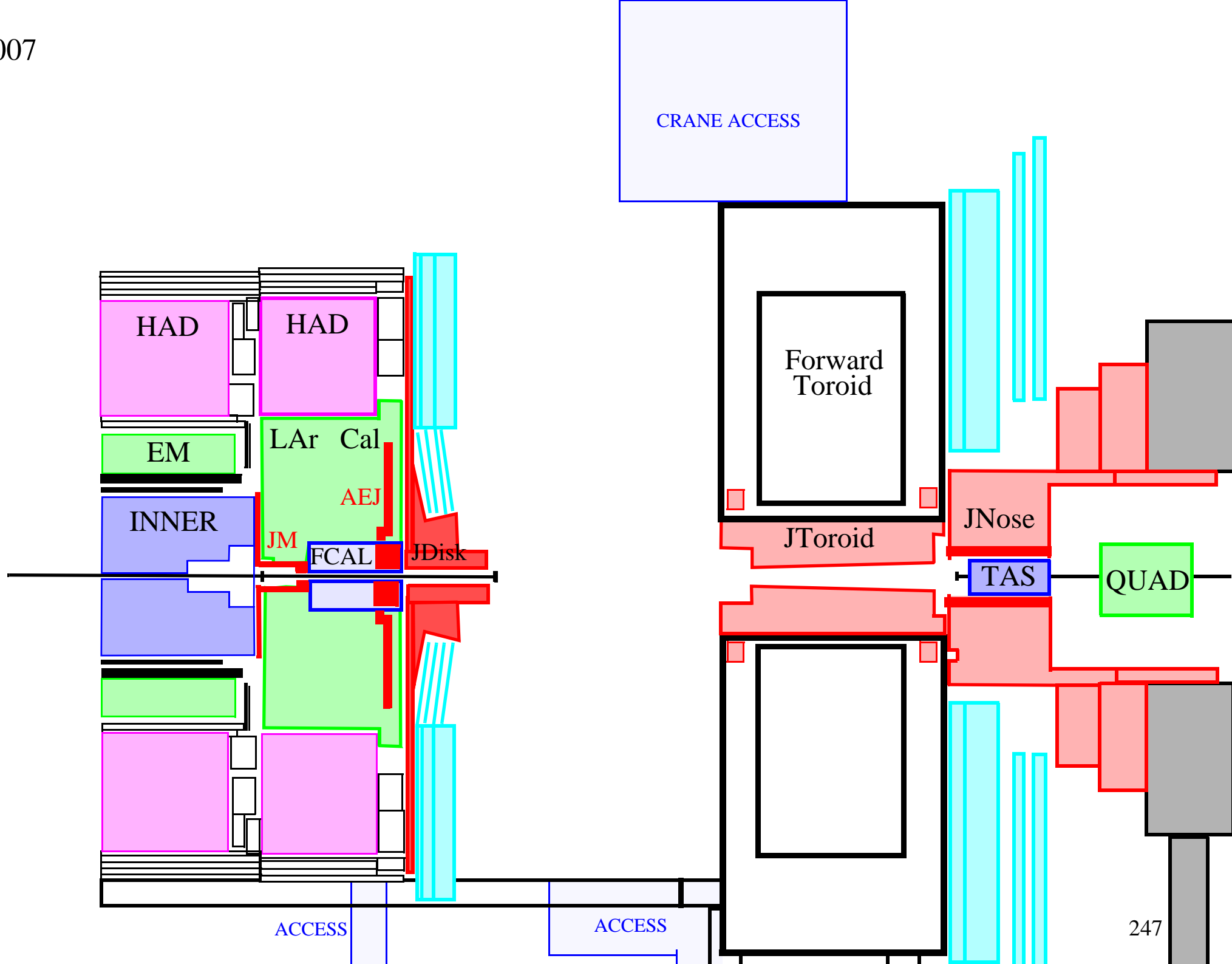

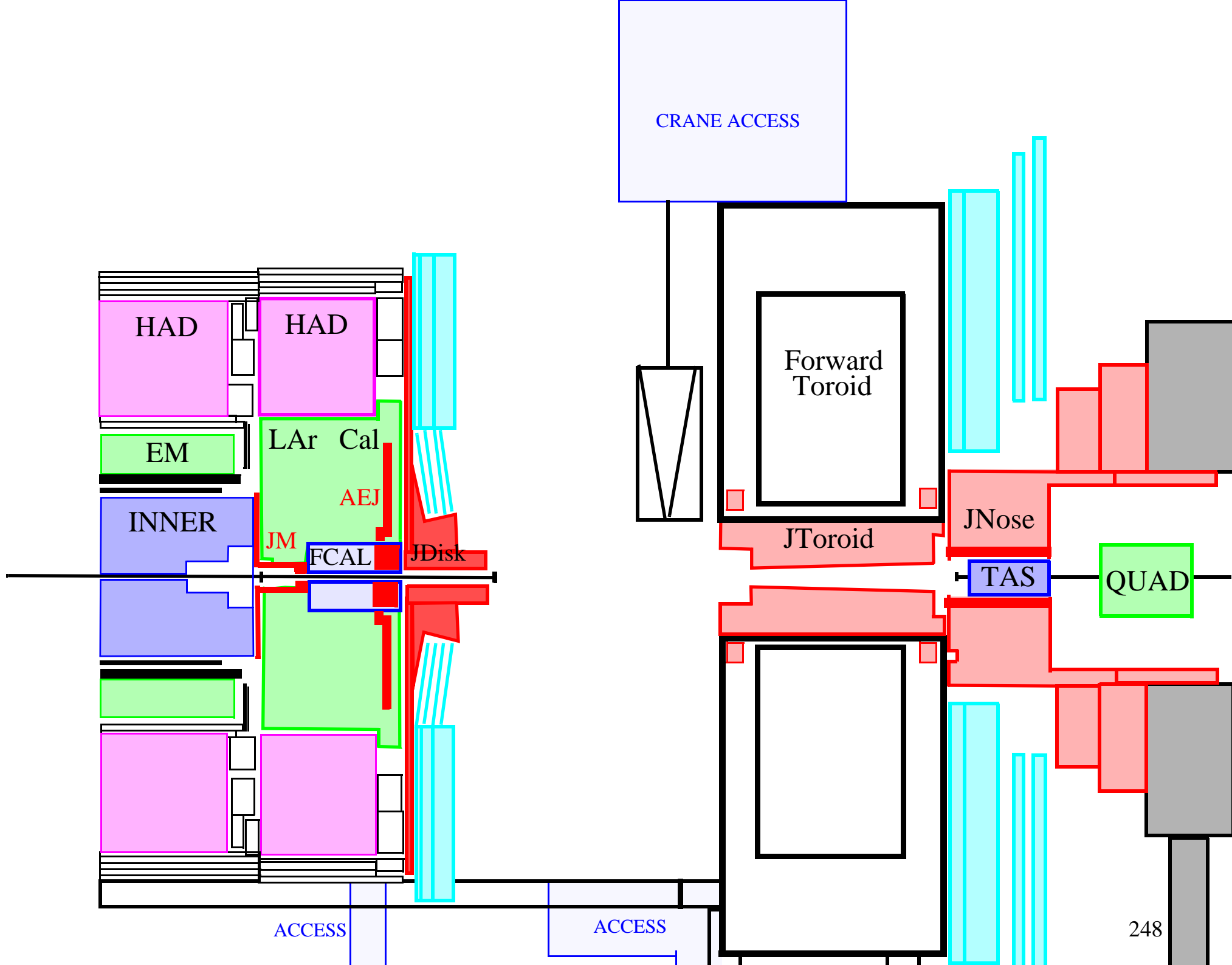

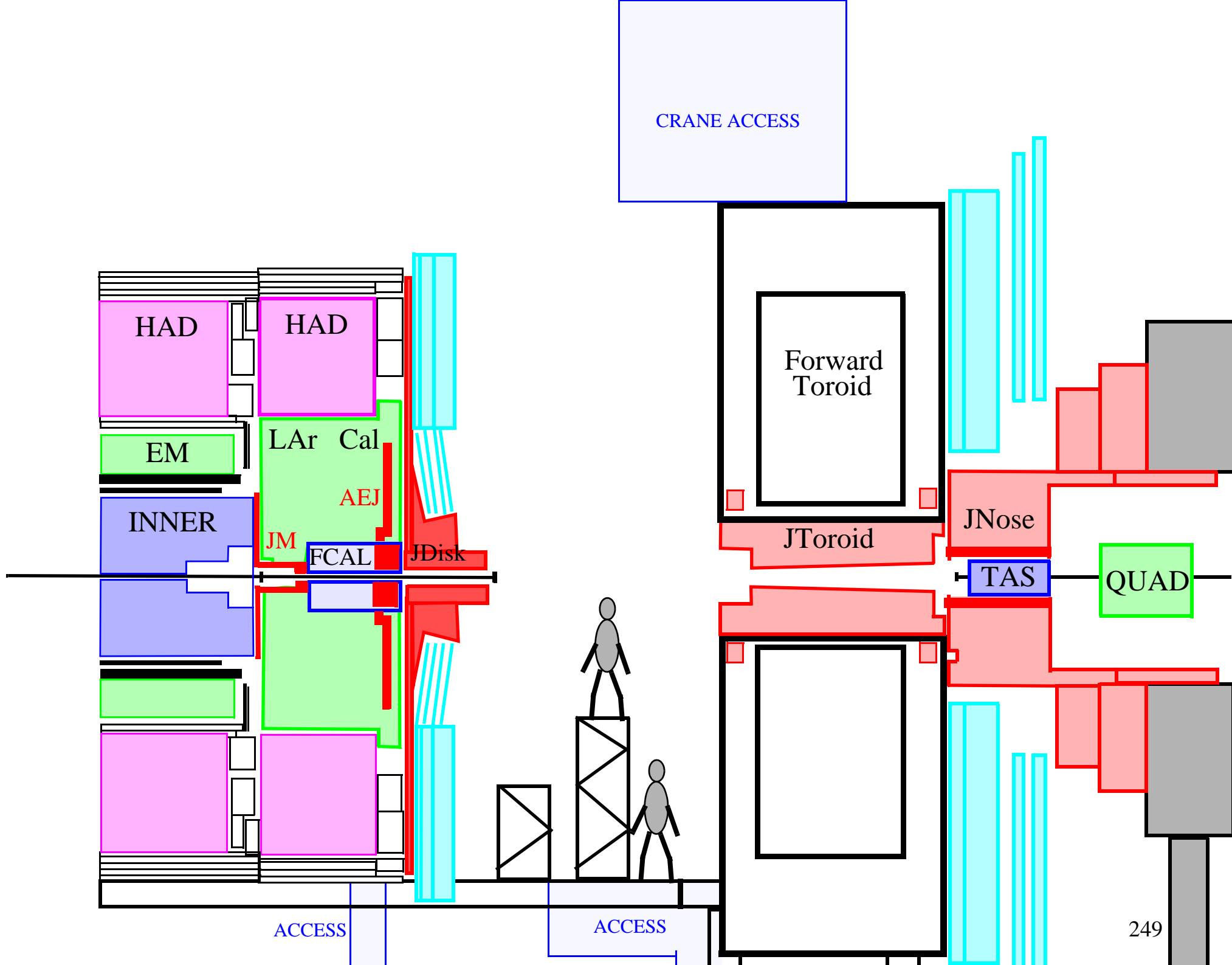

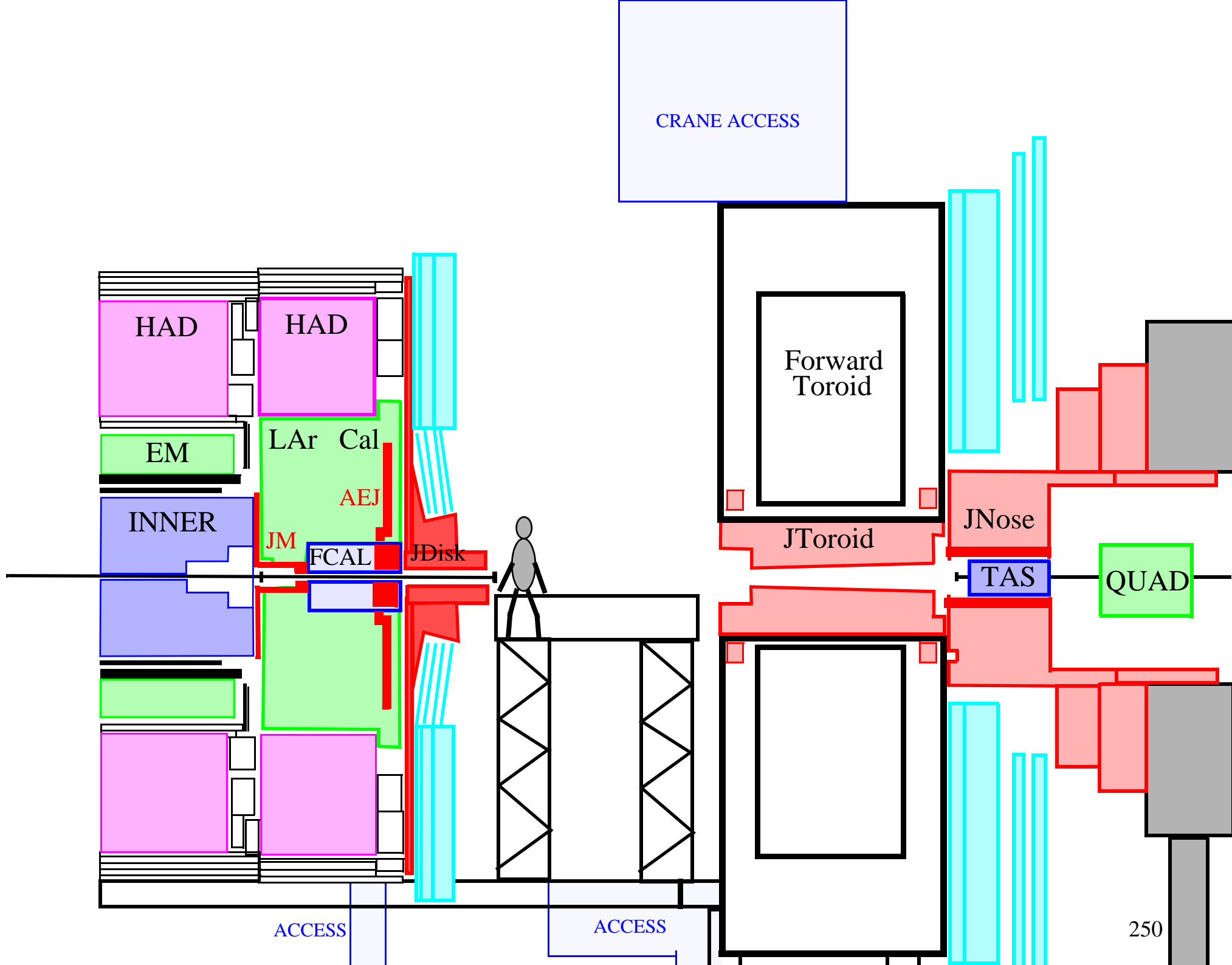

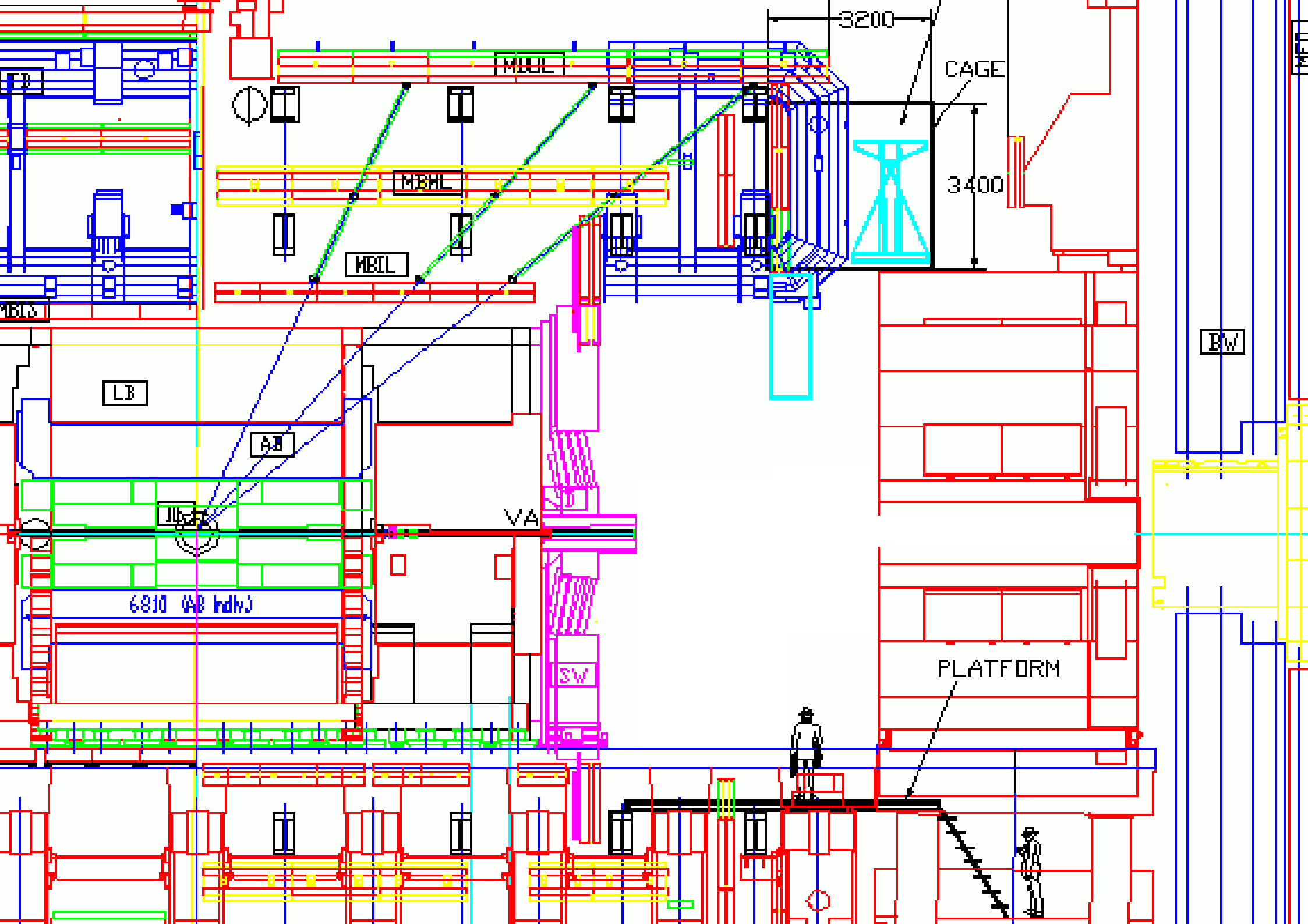

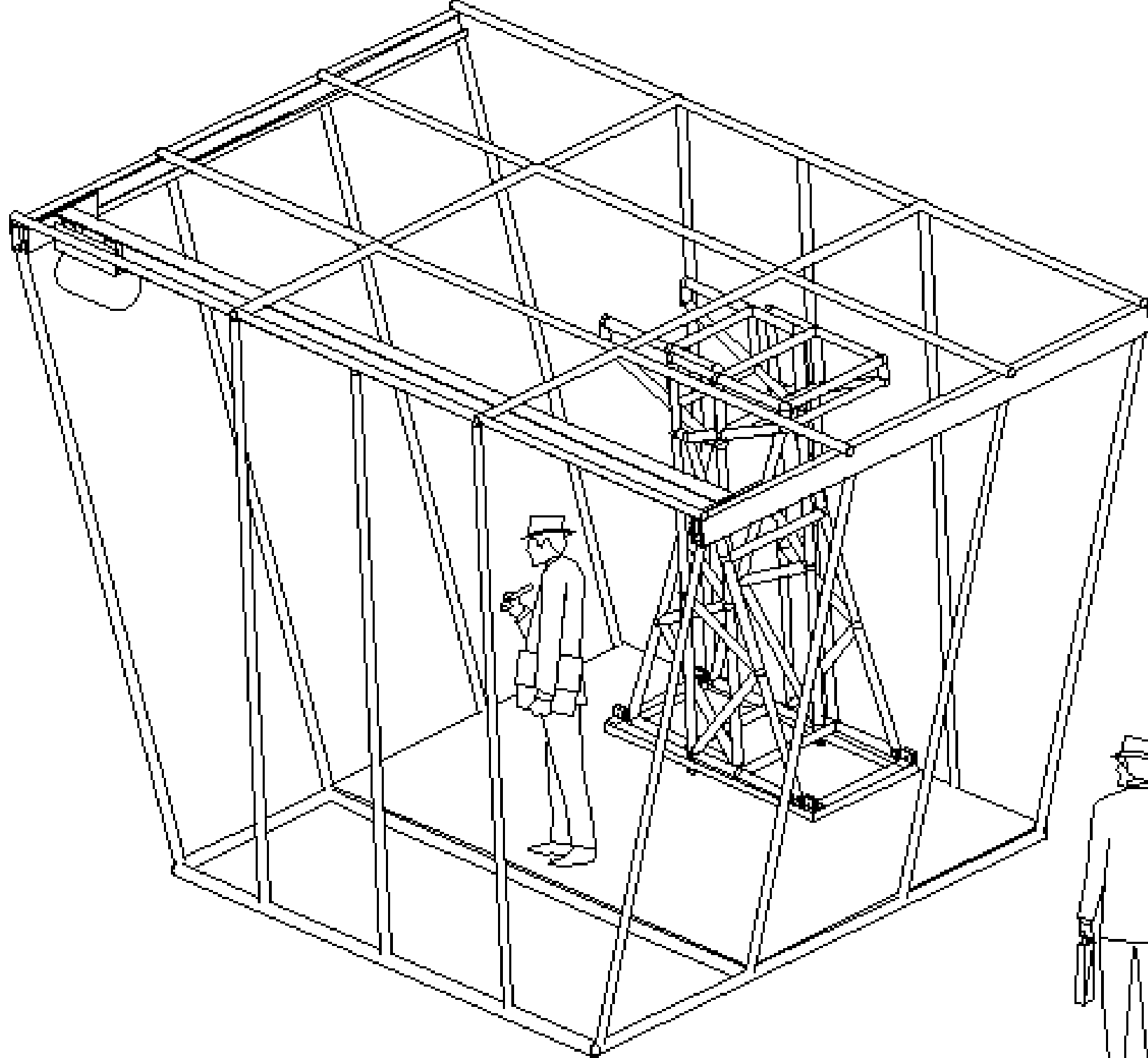

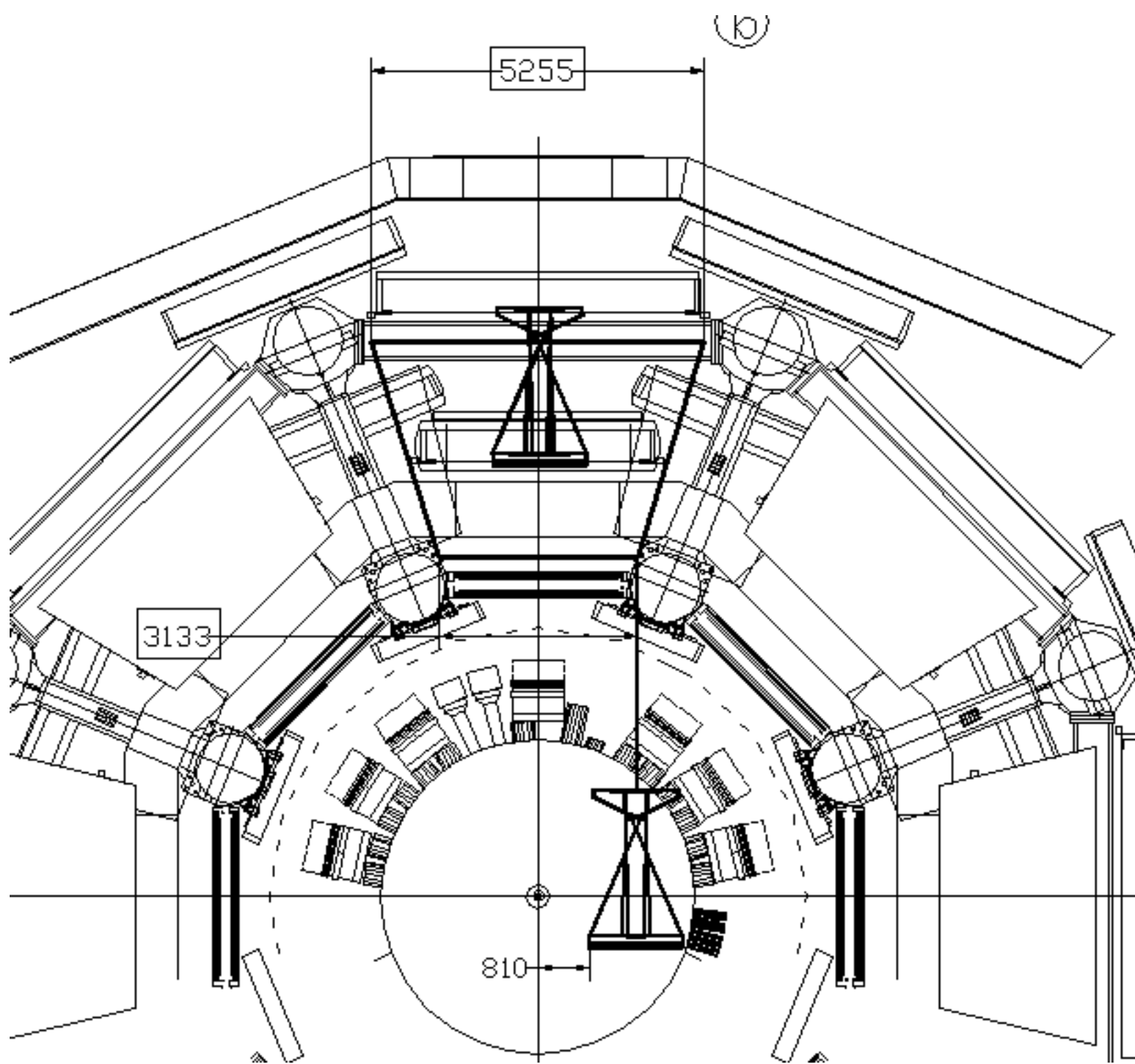

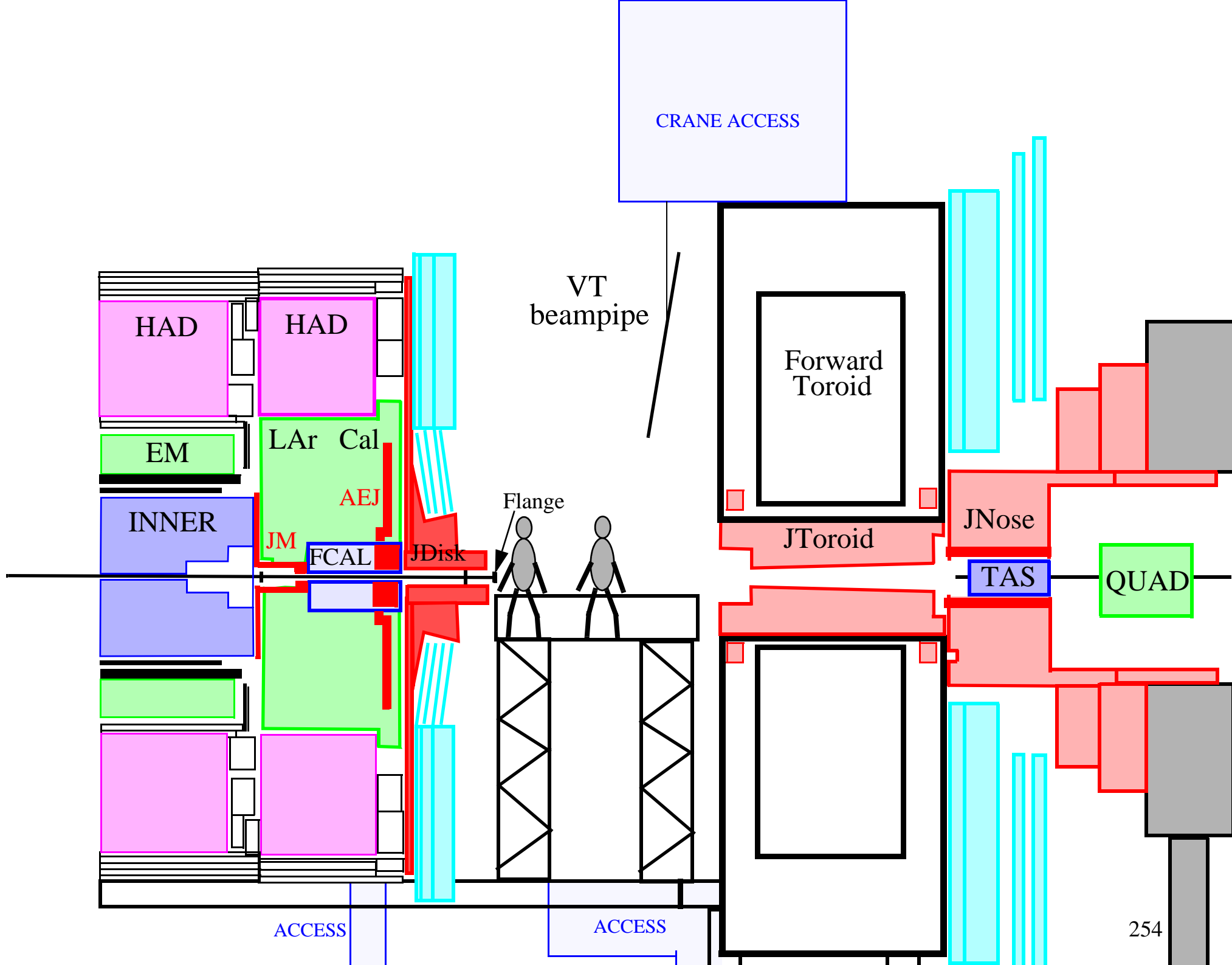

CRANE ACCESS

VT
beampipe

Forward
Toroid

HAD

HAD

EM

LAr Cal

INNER

AEJ

Flange

JM

FCAL

JDisk

JToroid

JNose

TAS

QUAD

ACCESS

ACCESS

254

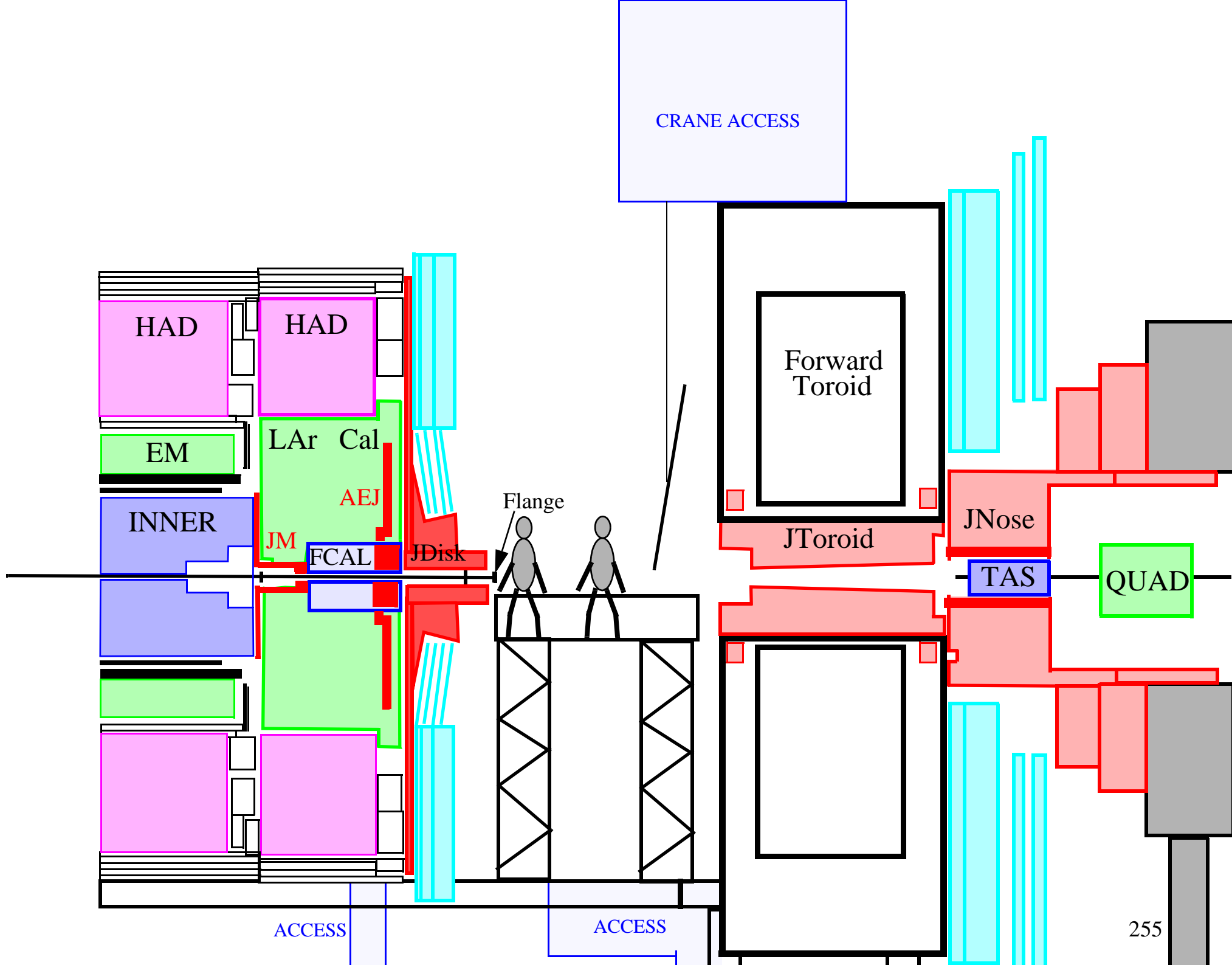

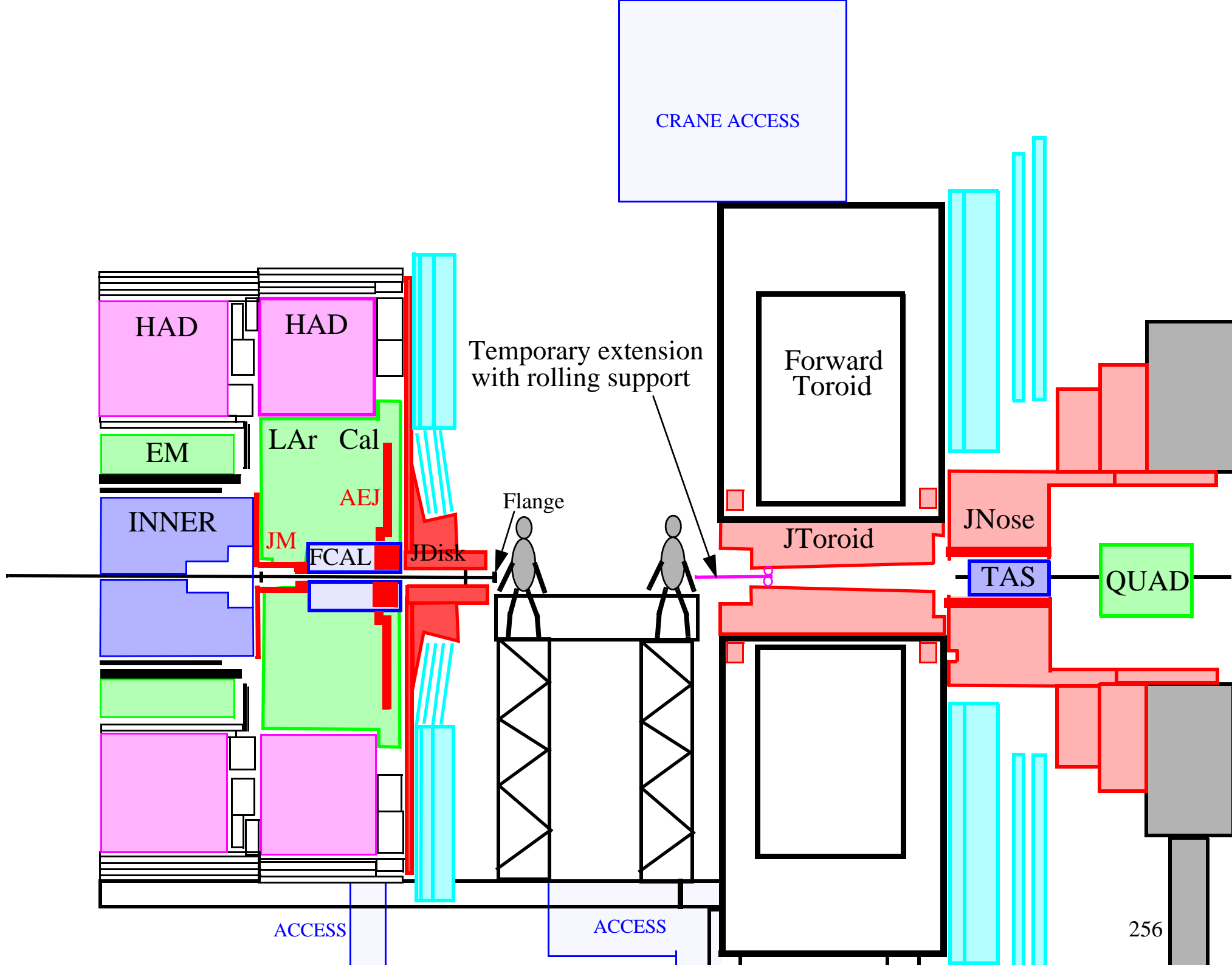

CRANE ACCESS

HAD

HAD

EM

INNER

JM

FCAL

JDisk

Temporary extension with rolling support

Flange

Forward Toroid

JToroid

JNose

TAS

QUAD

ACCESS

ACCESS

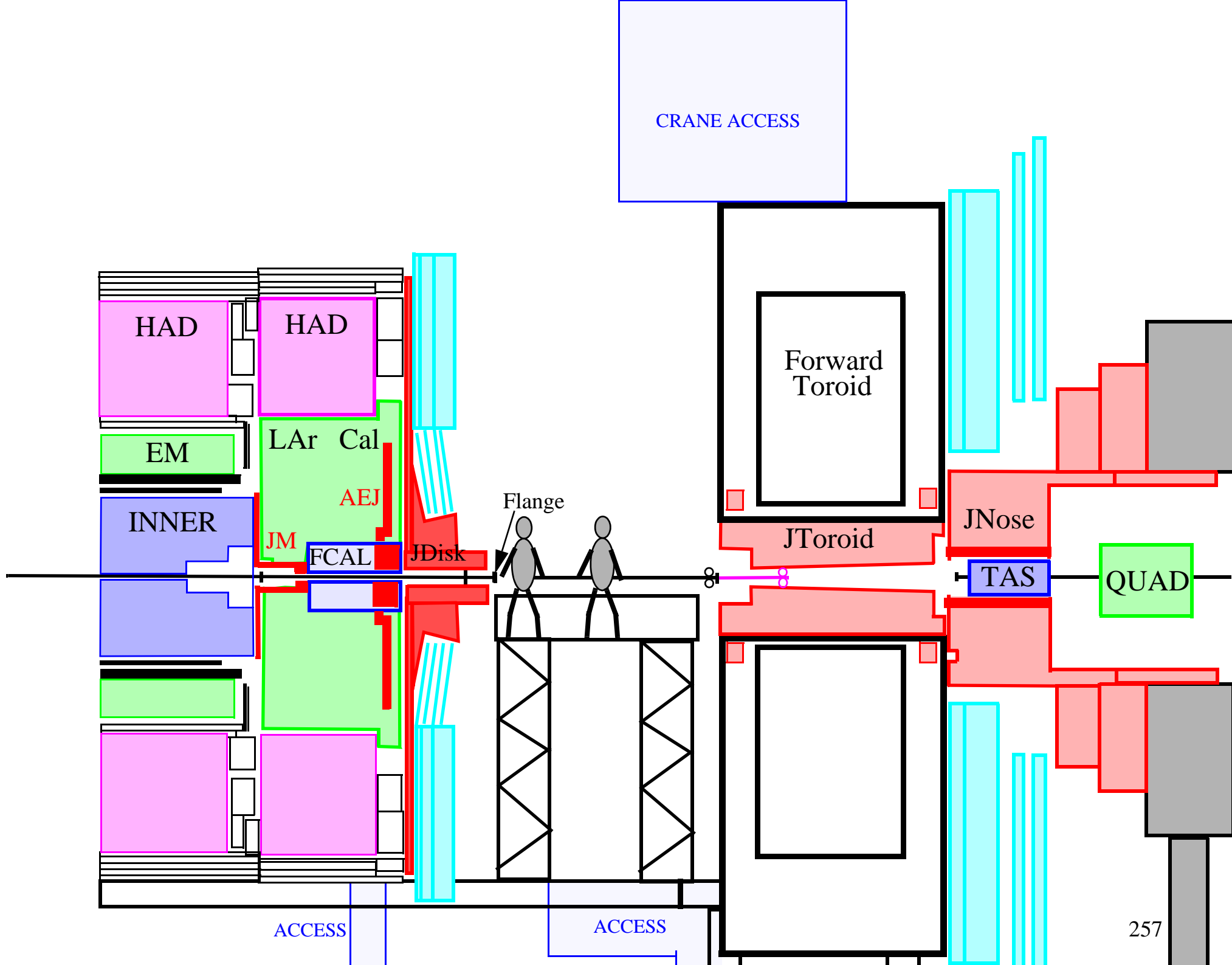

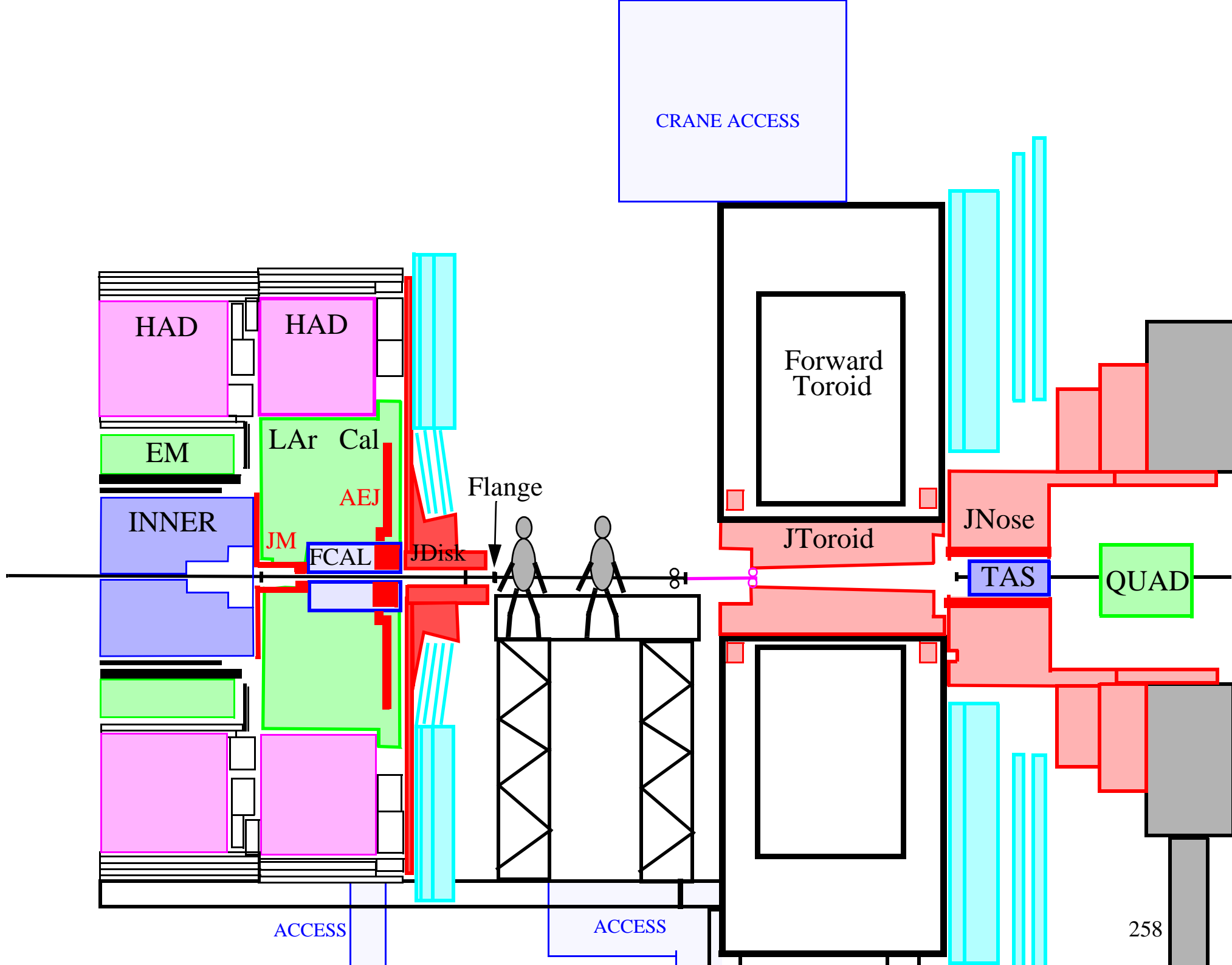

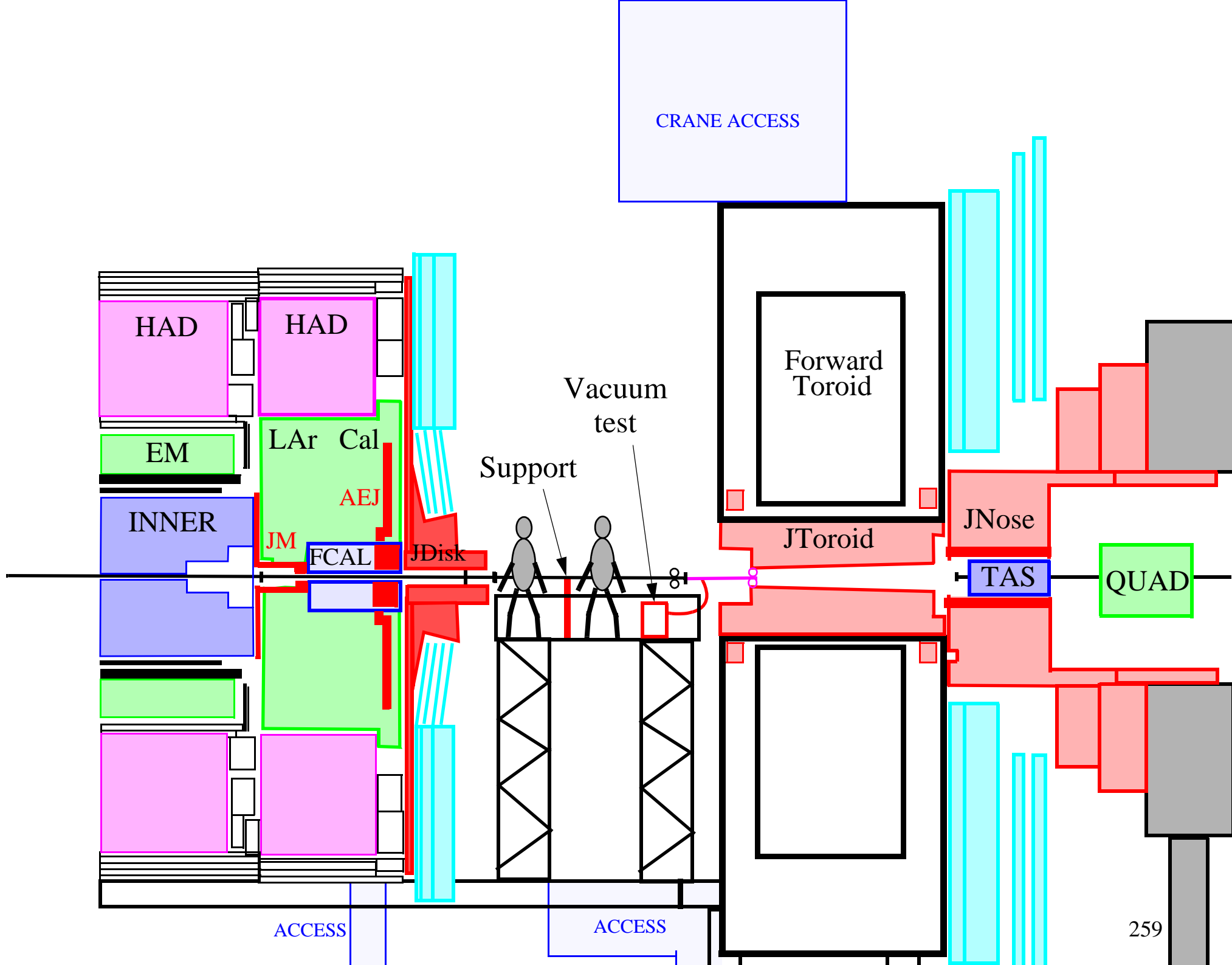

CRANE ACCESS

HAD

HAD

EM

INNER

JM

FCAL

AEJ

JDisk

Support

Vacuum test

Forward Toroid

JToroid

JNose

TAS

QUAD

ACCESS

ACCESS

259

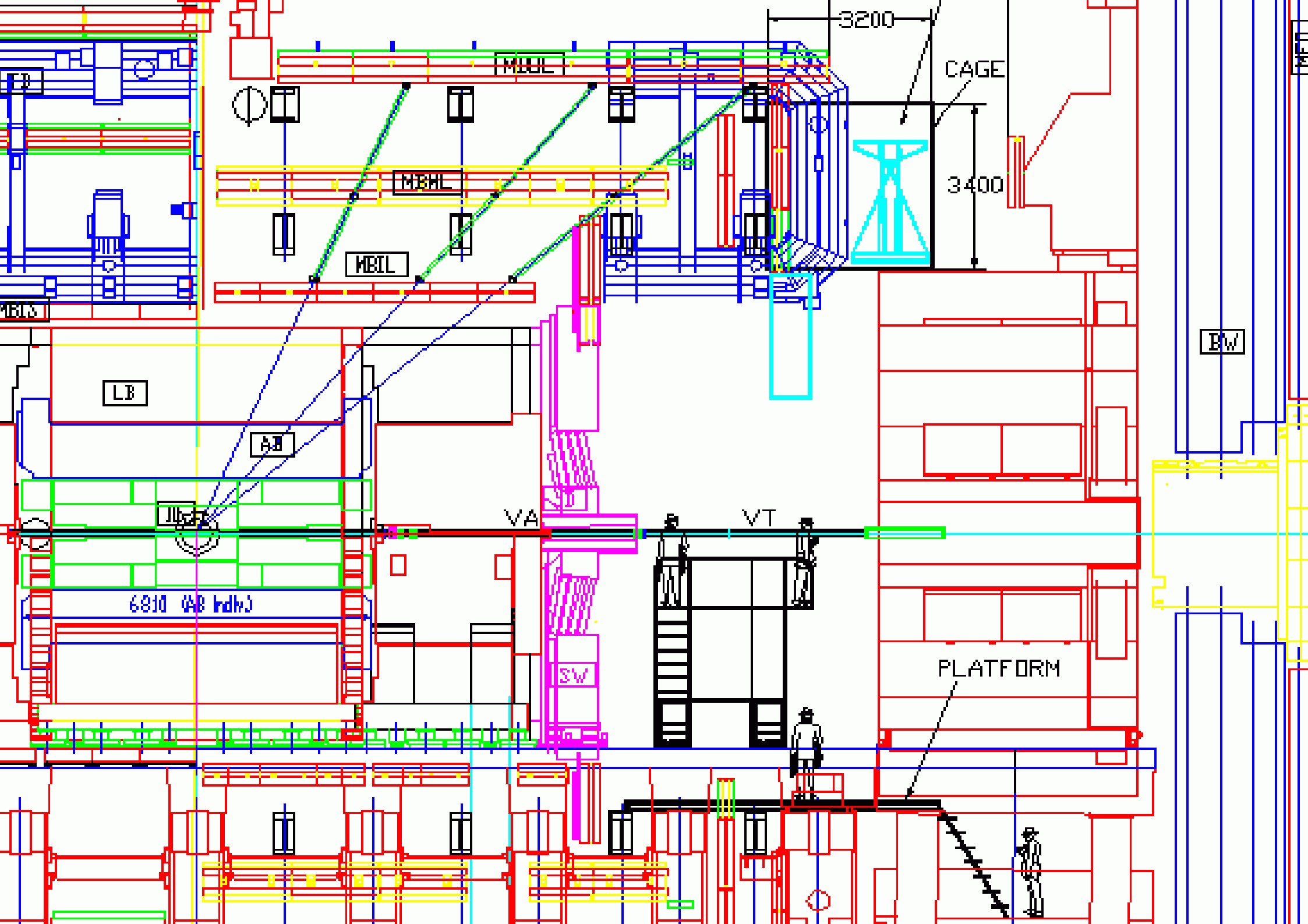

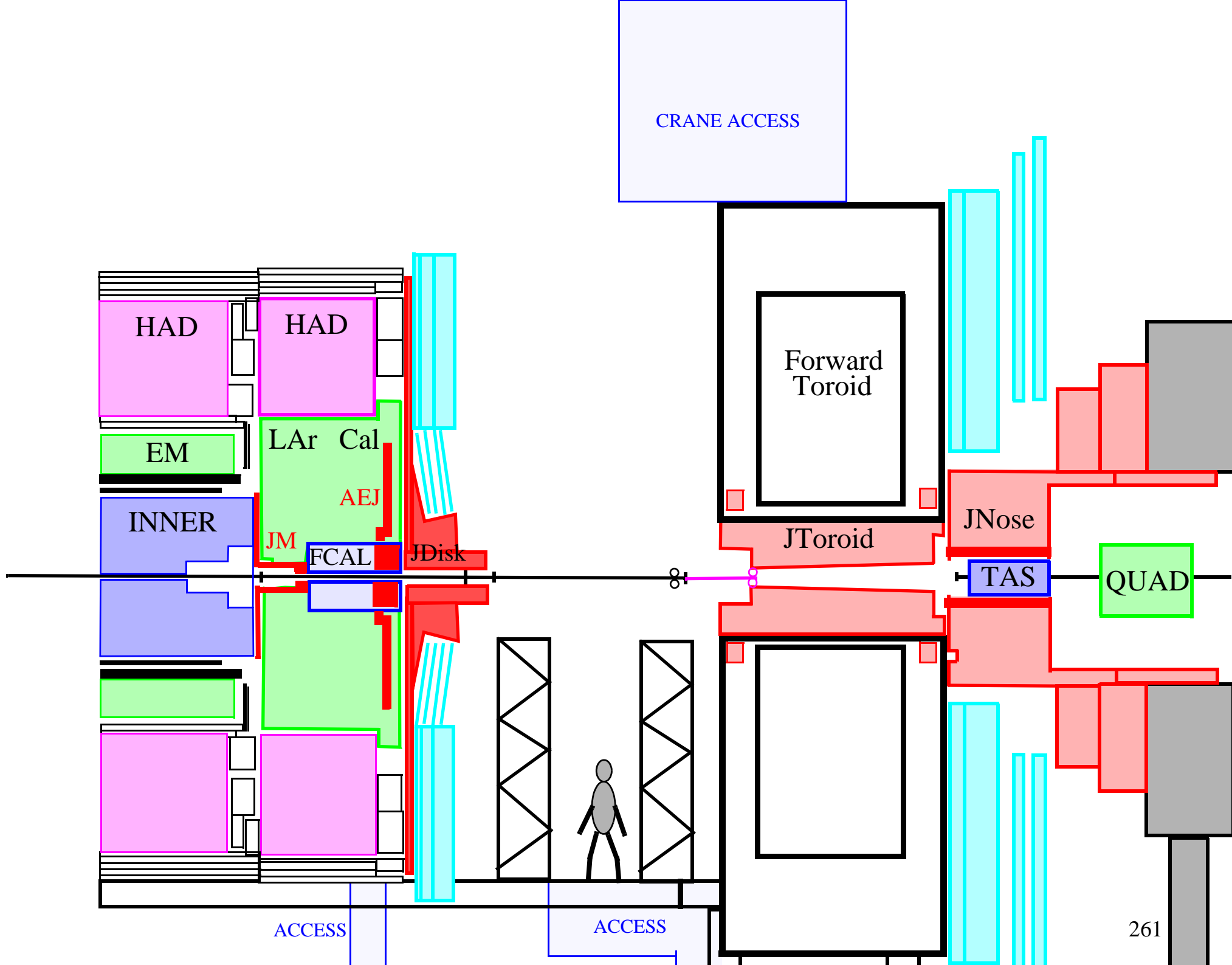

CRANE ACCESS

HAD

HAD

EM

INNER

JM

FCAL

AEJ

JDisk

Forward Toroid

JToroid

JNose

TAS

QUAD

ACCESS

ACCESS

261

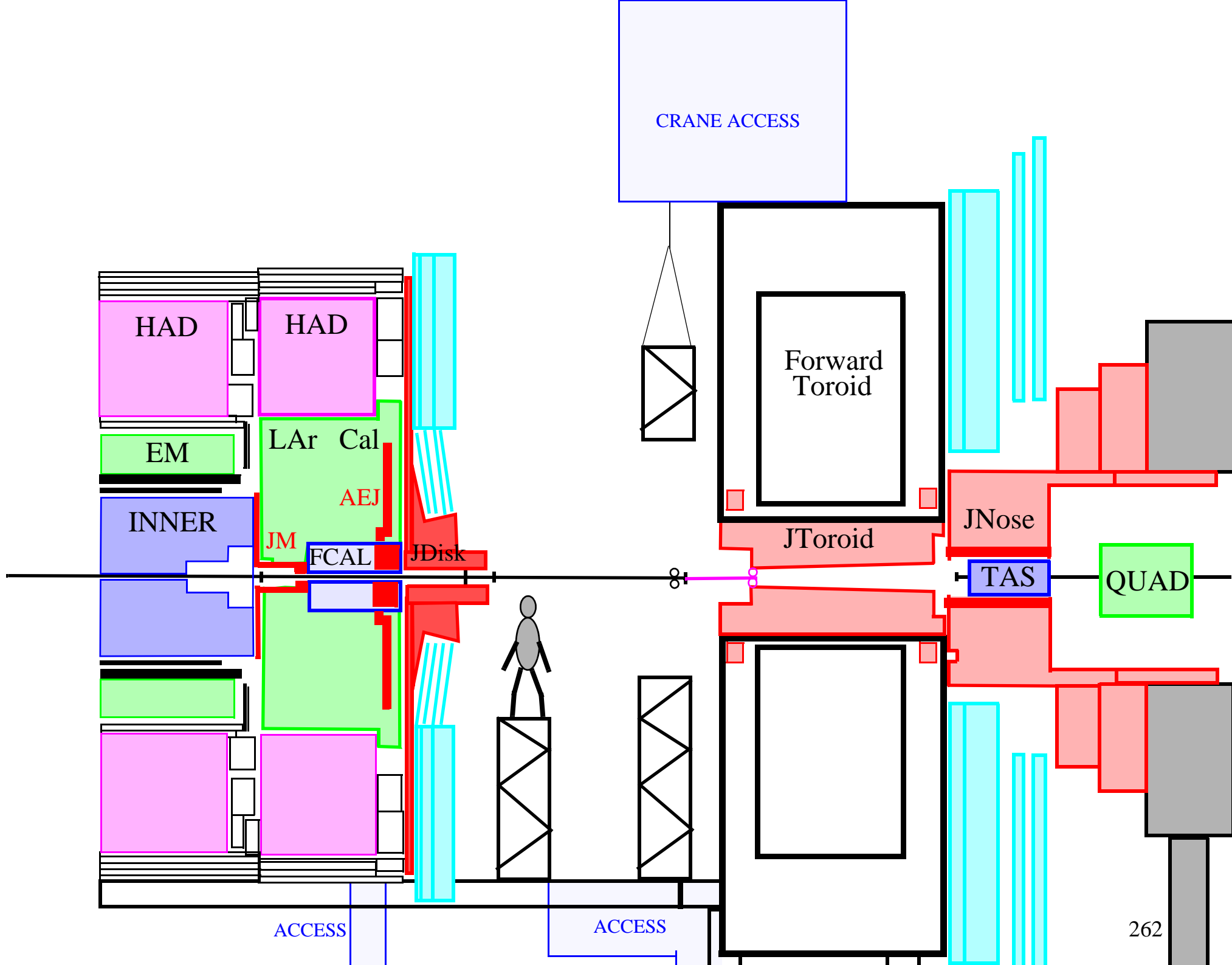

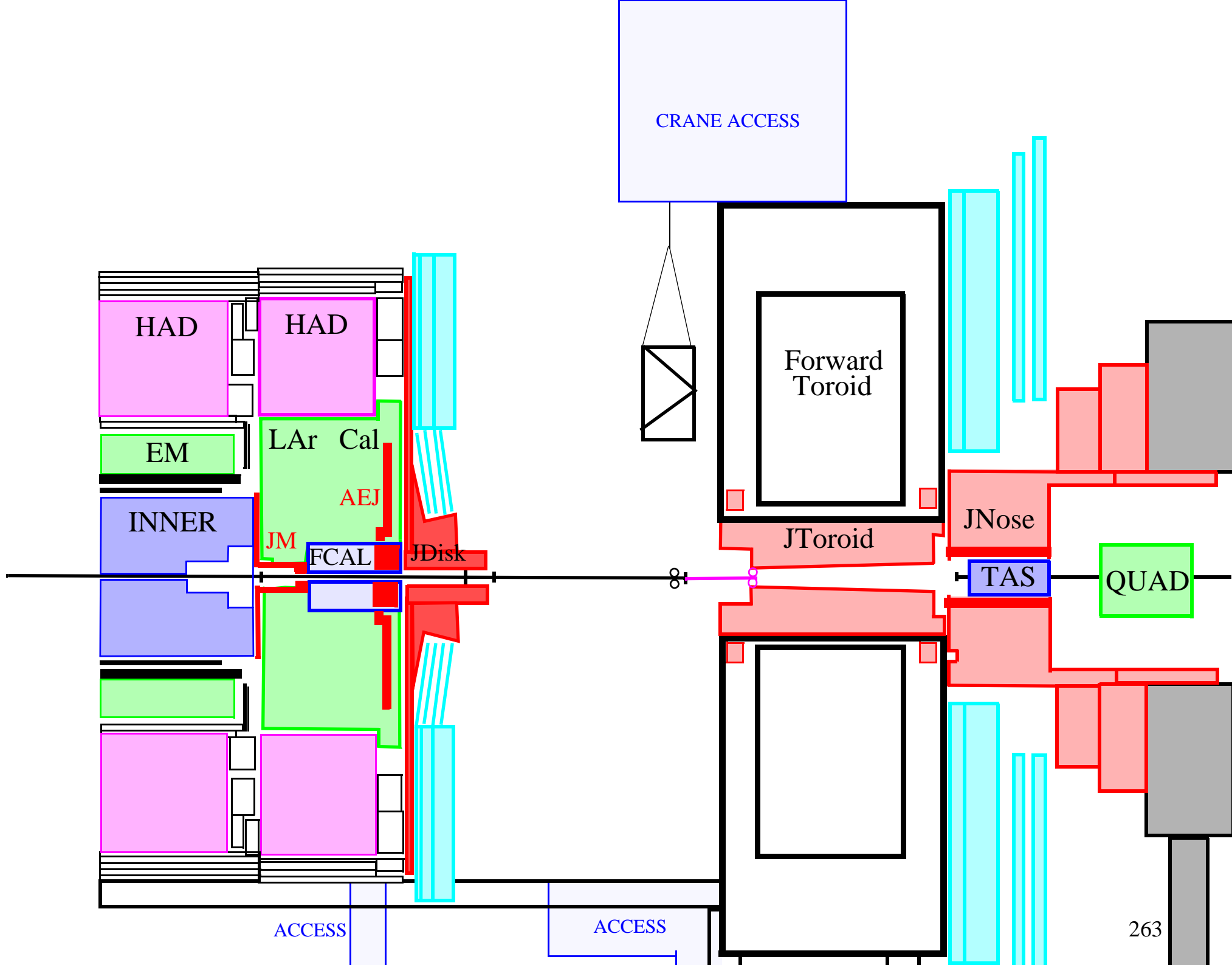

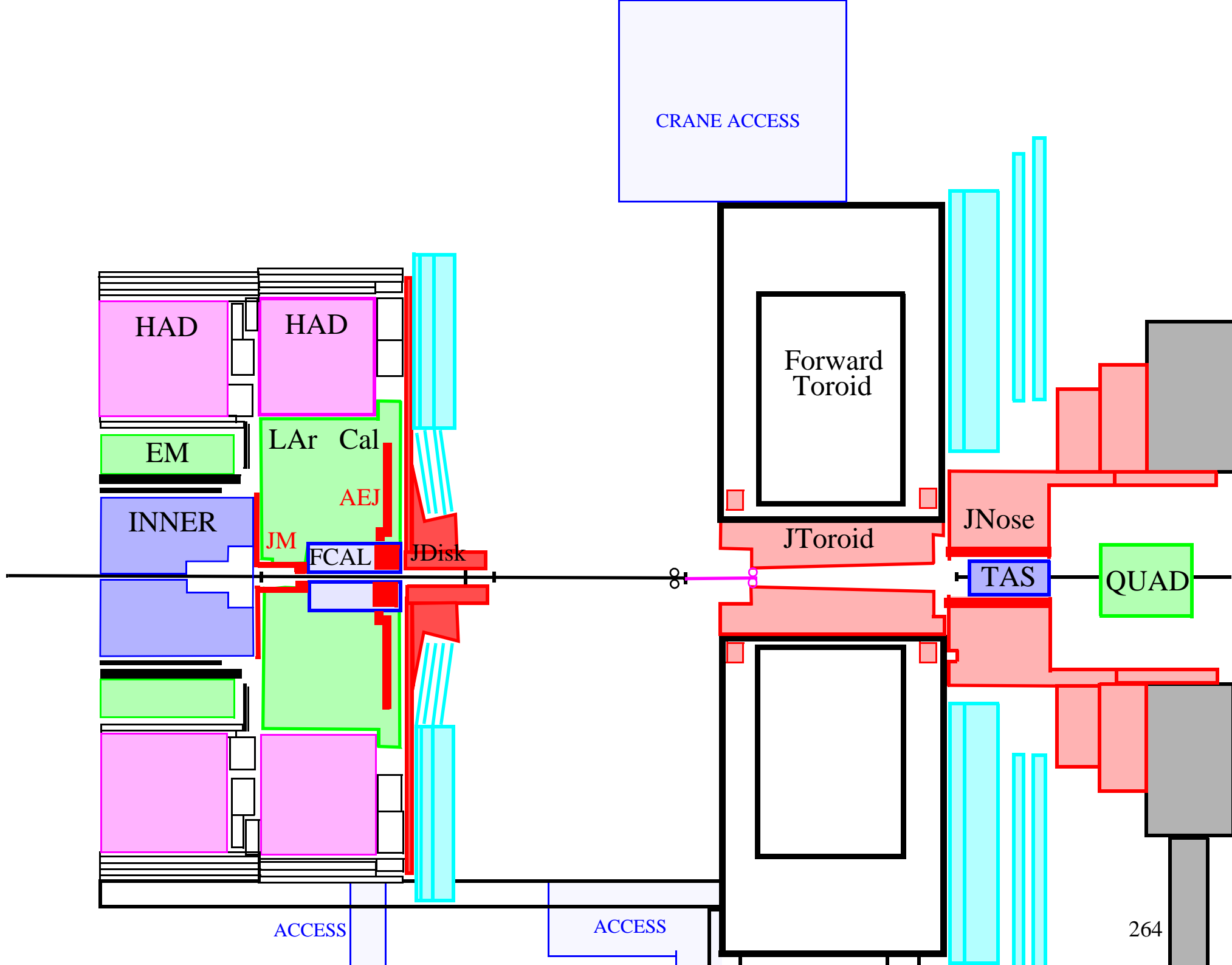

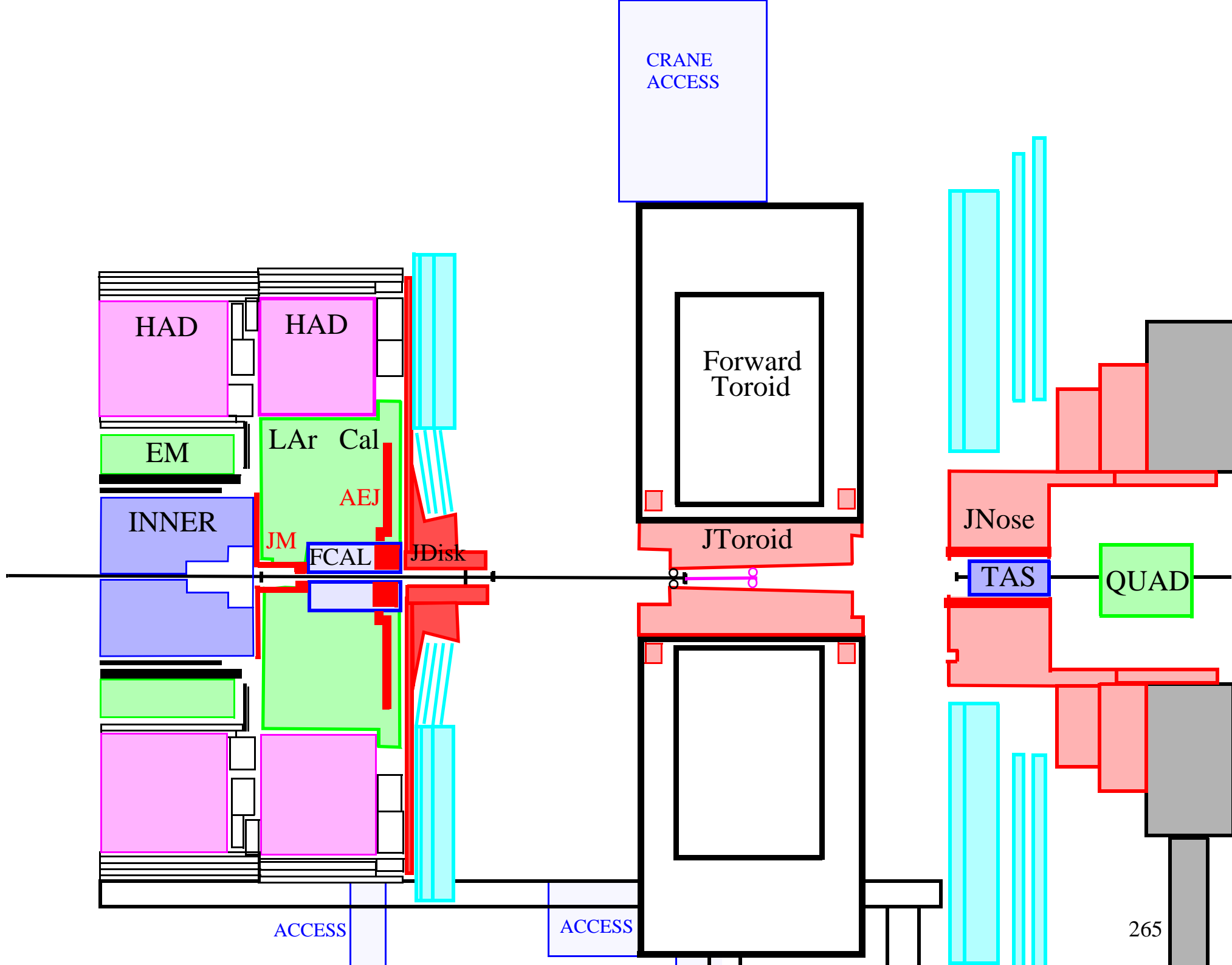

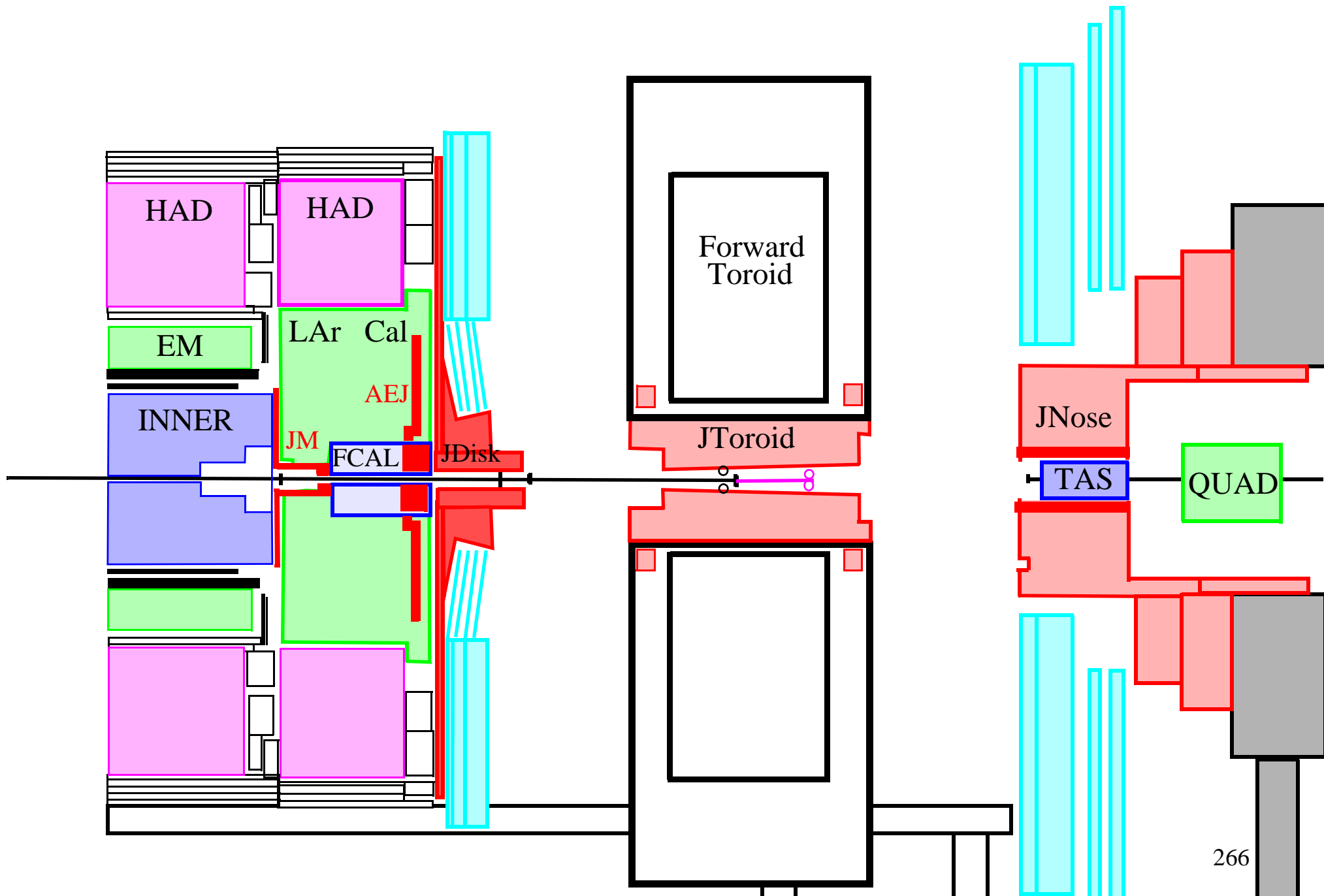

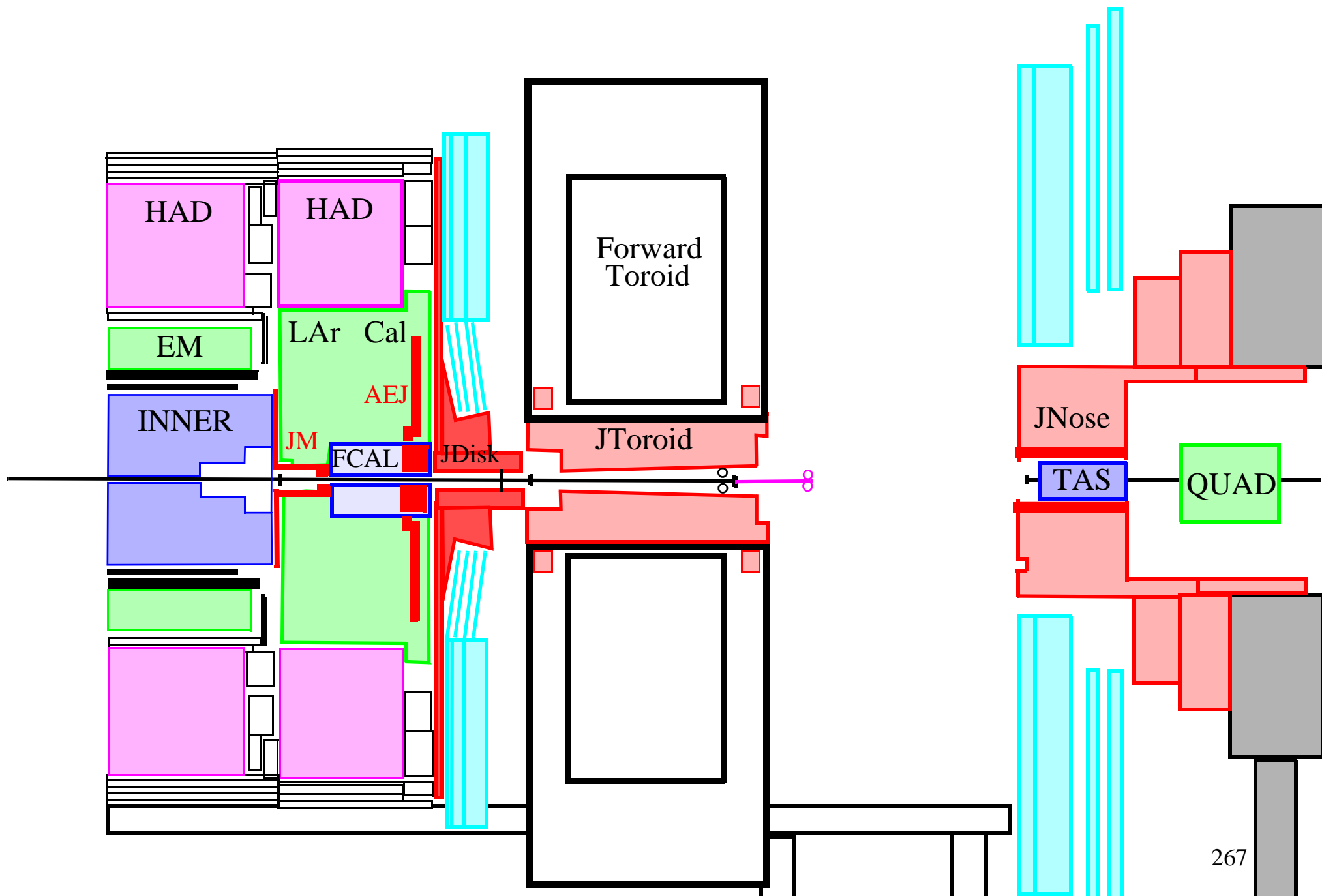

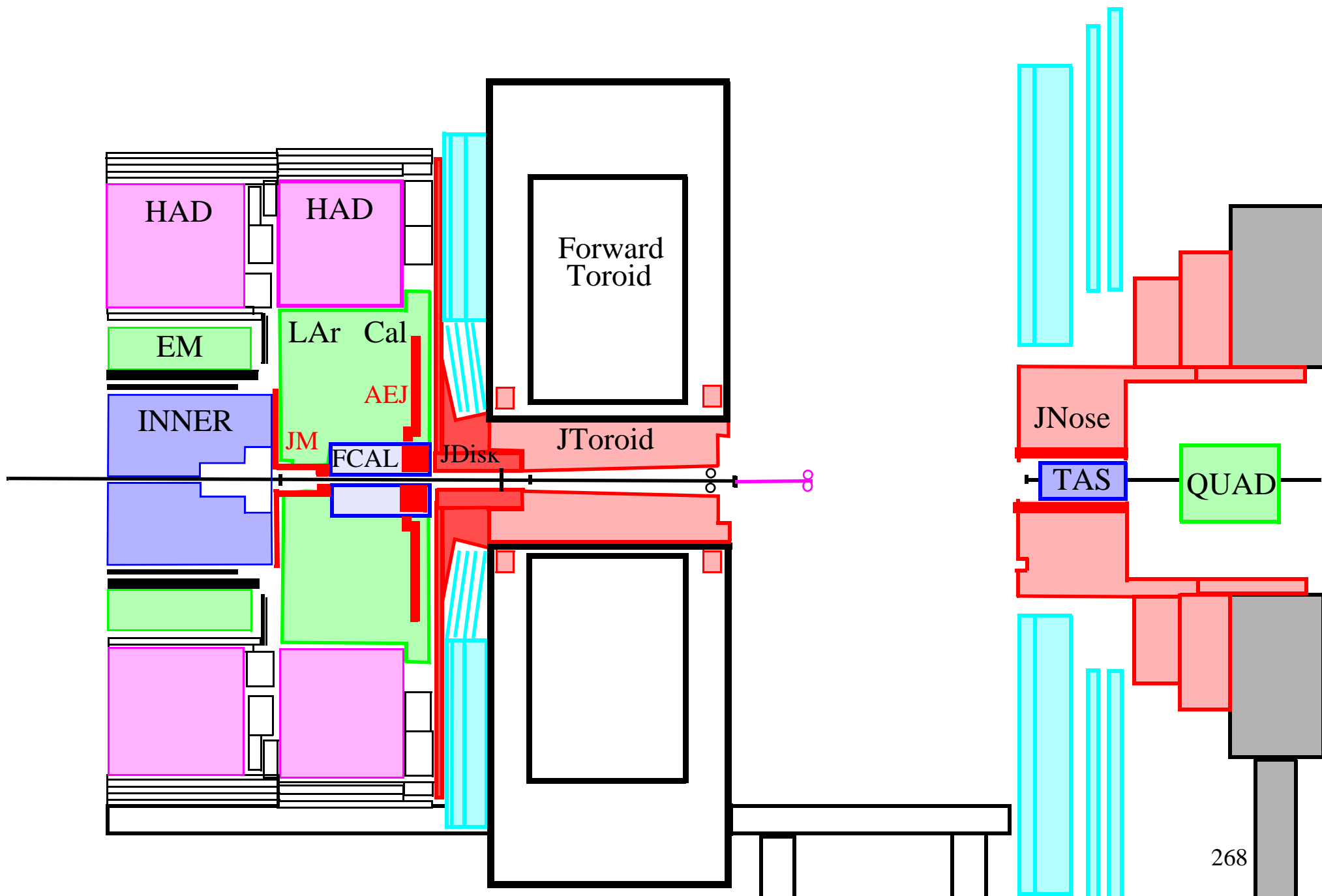

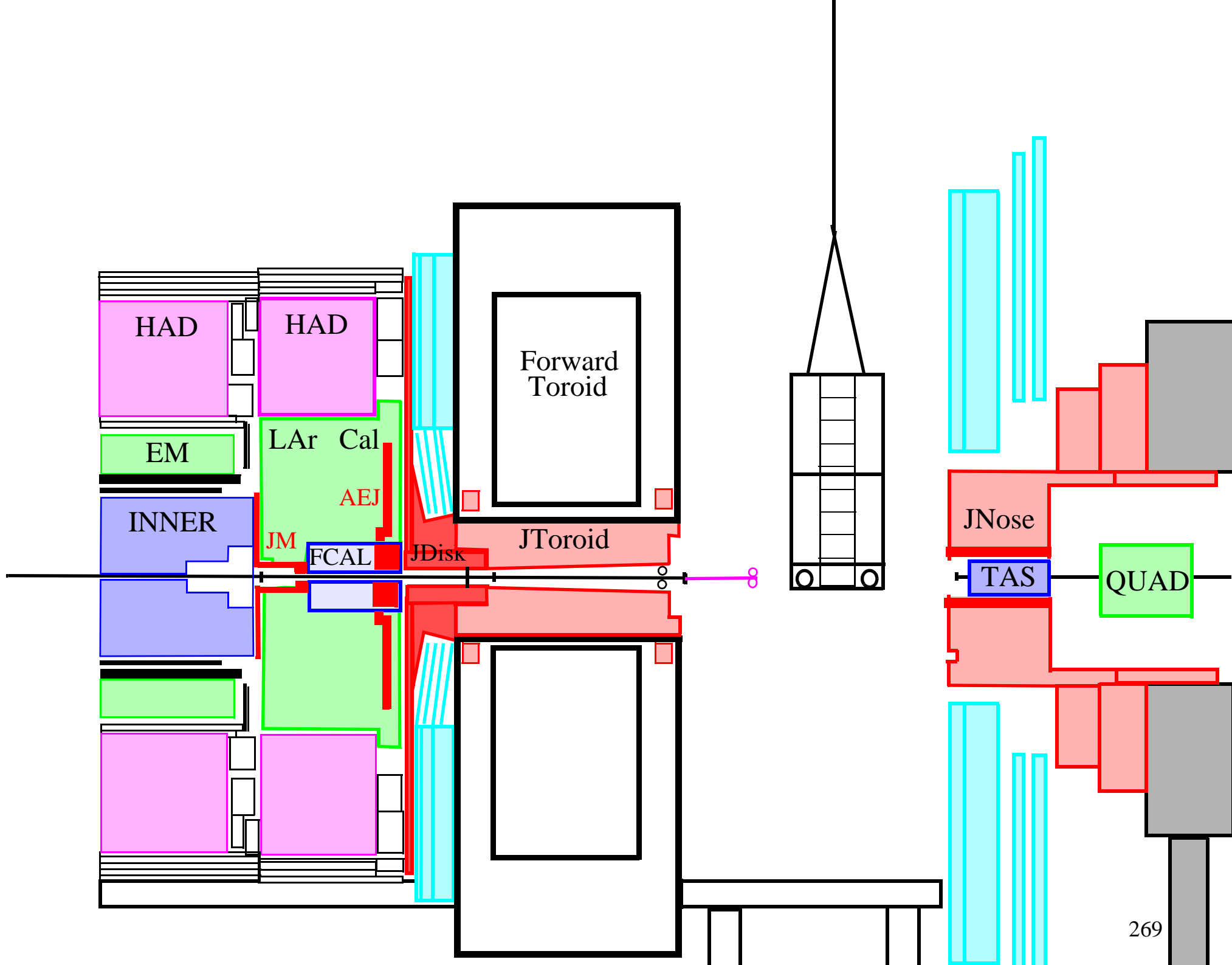

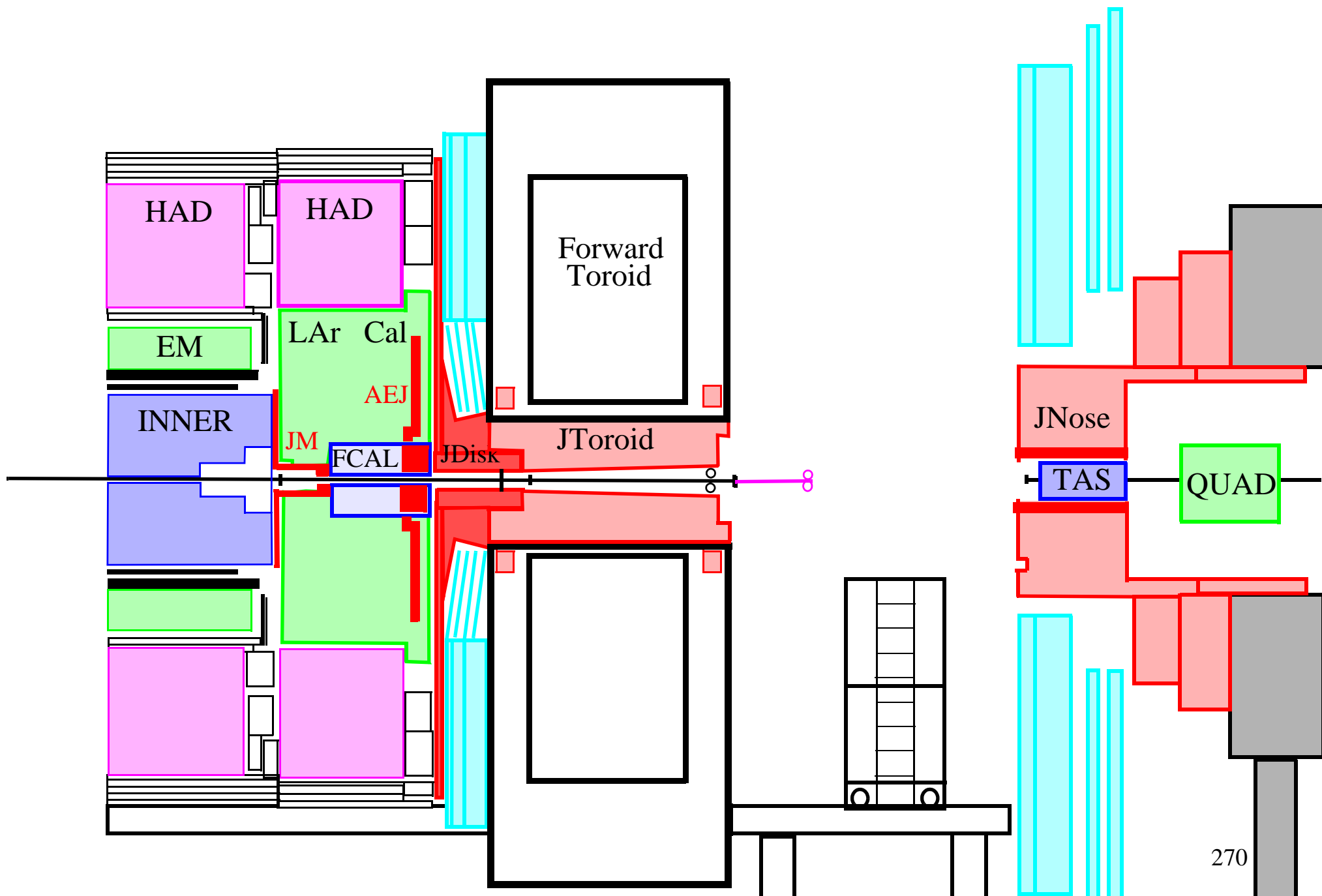

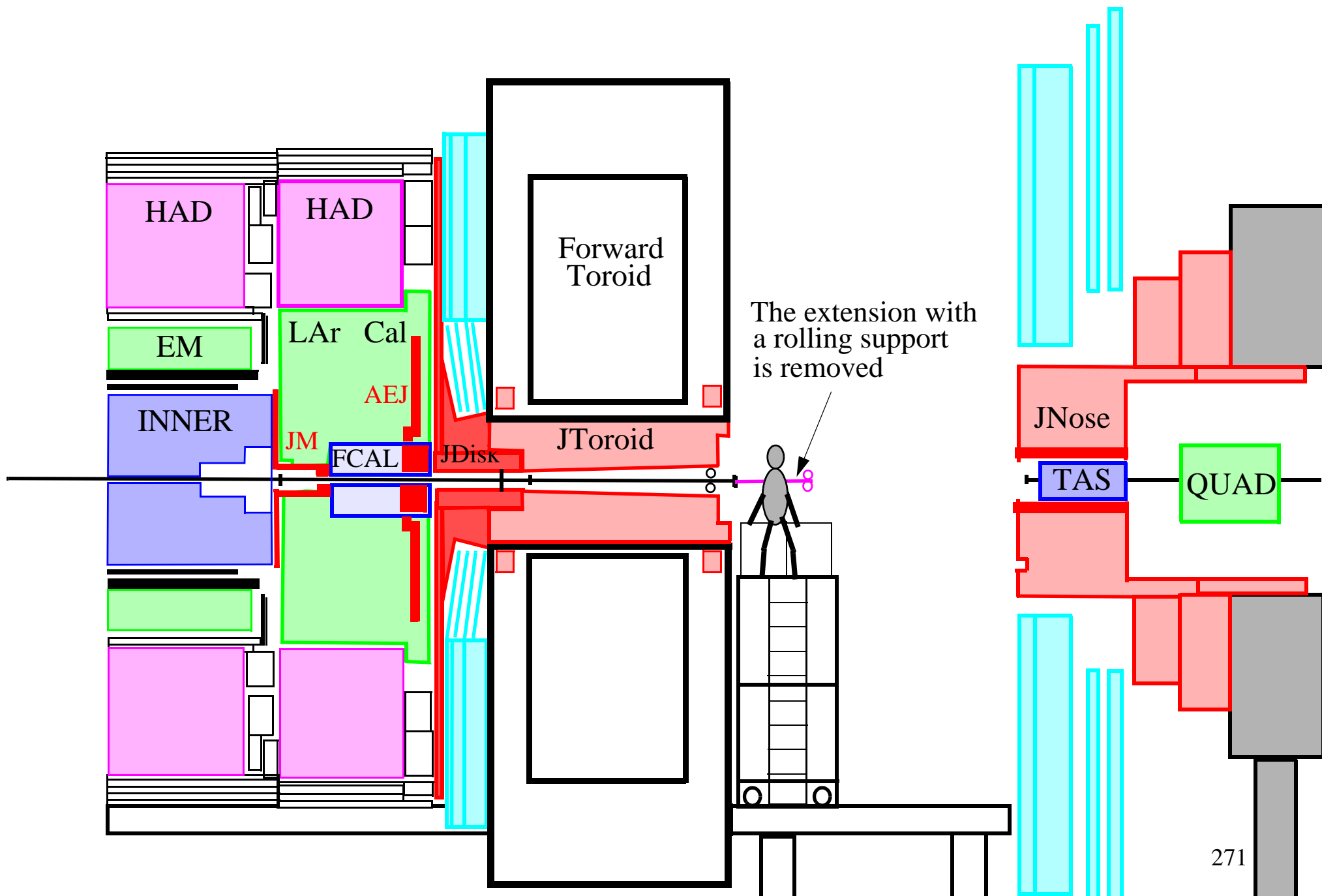

The extension with a rolling support is removed

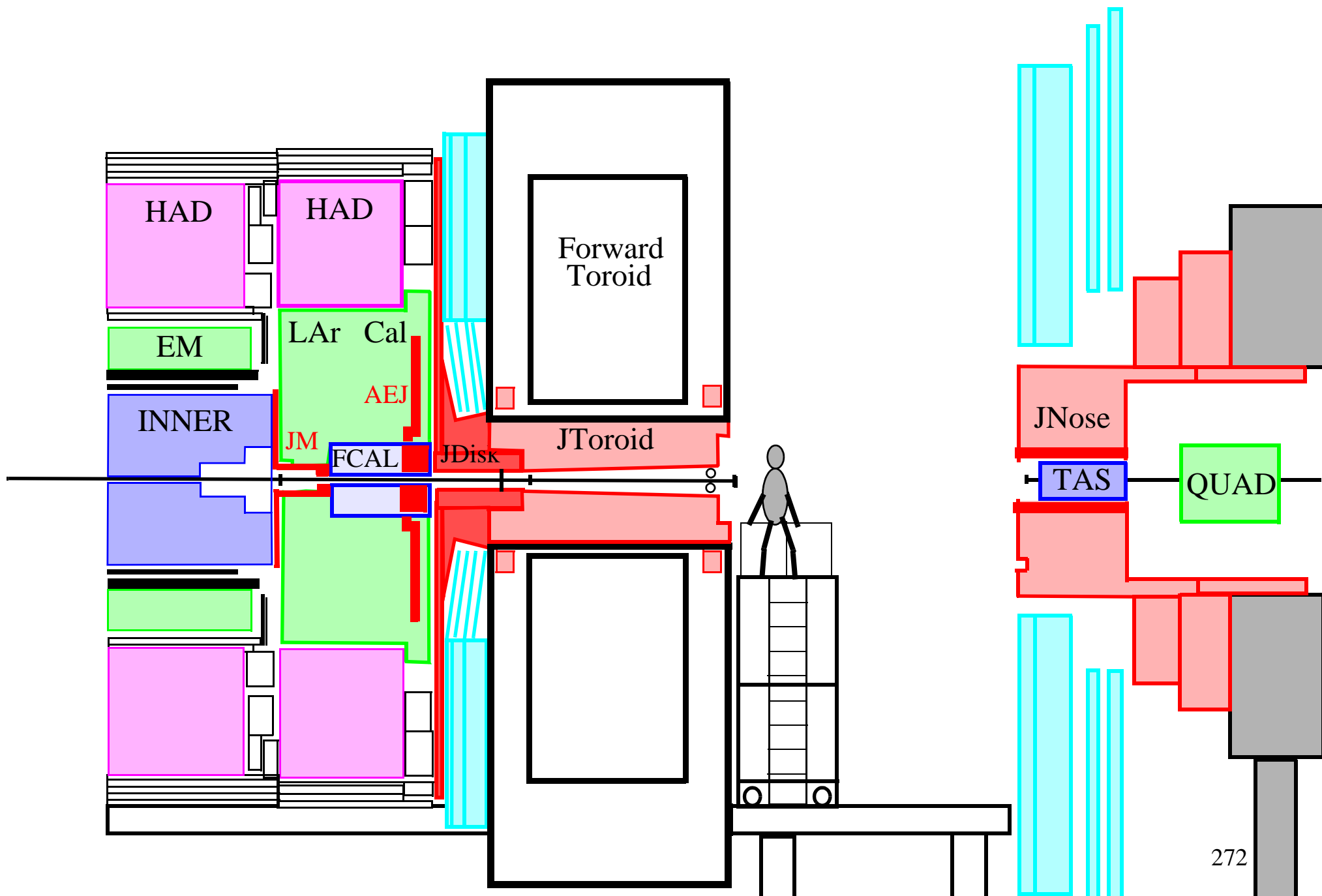

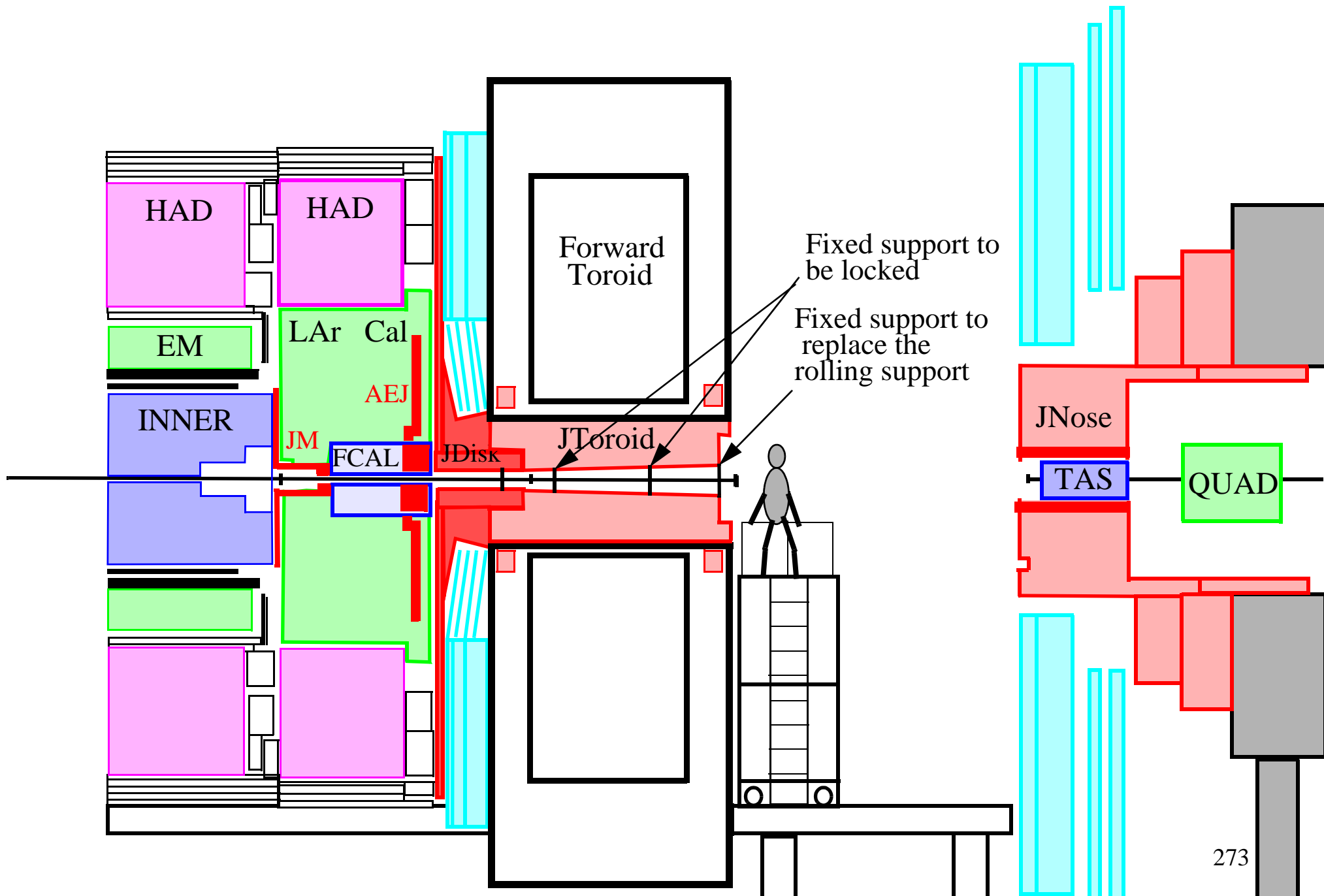

Beampipe supports

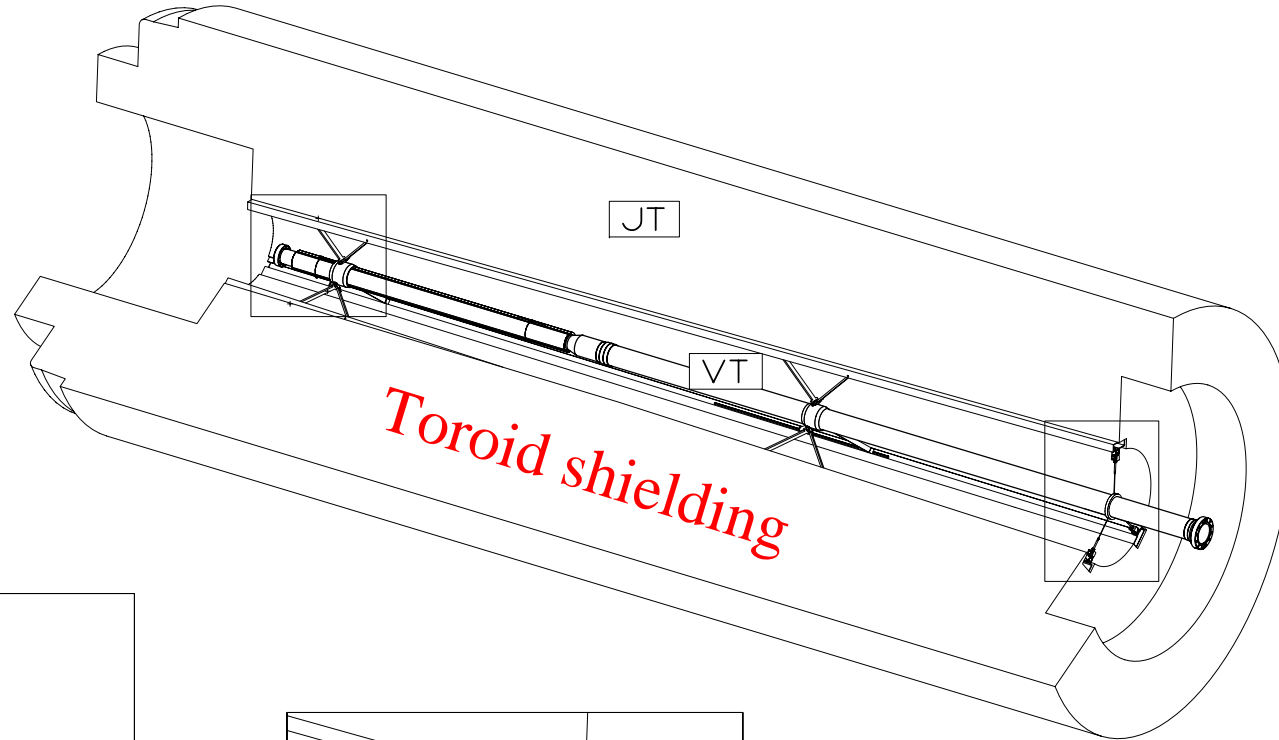

This support has to be locked.

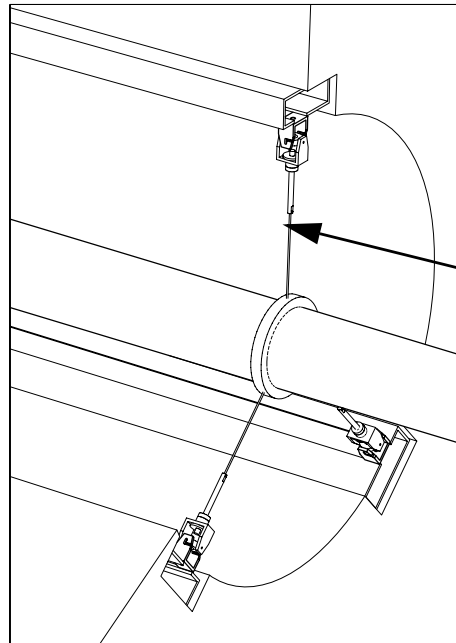
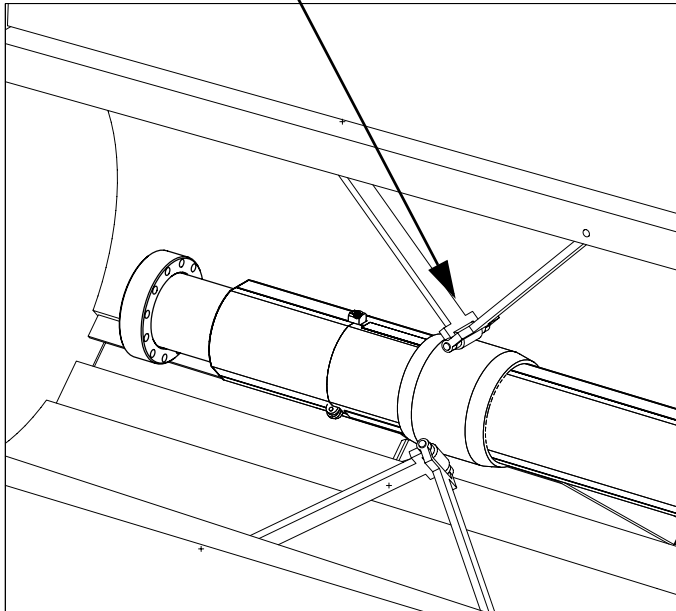
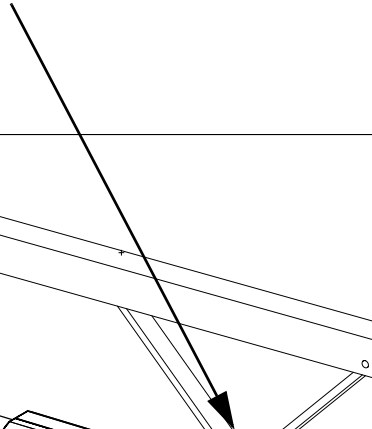

This support has to be attached and the rolling support has to be removed.

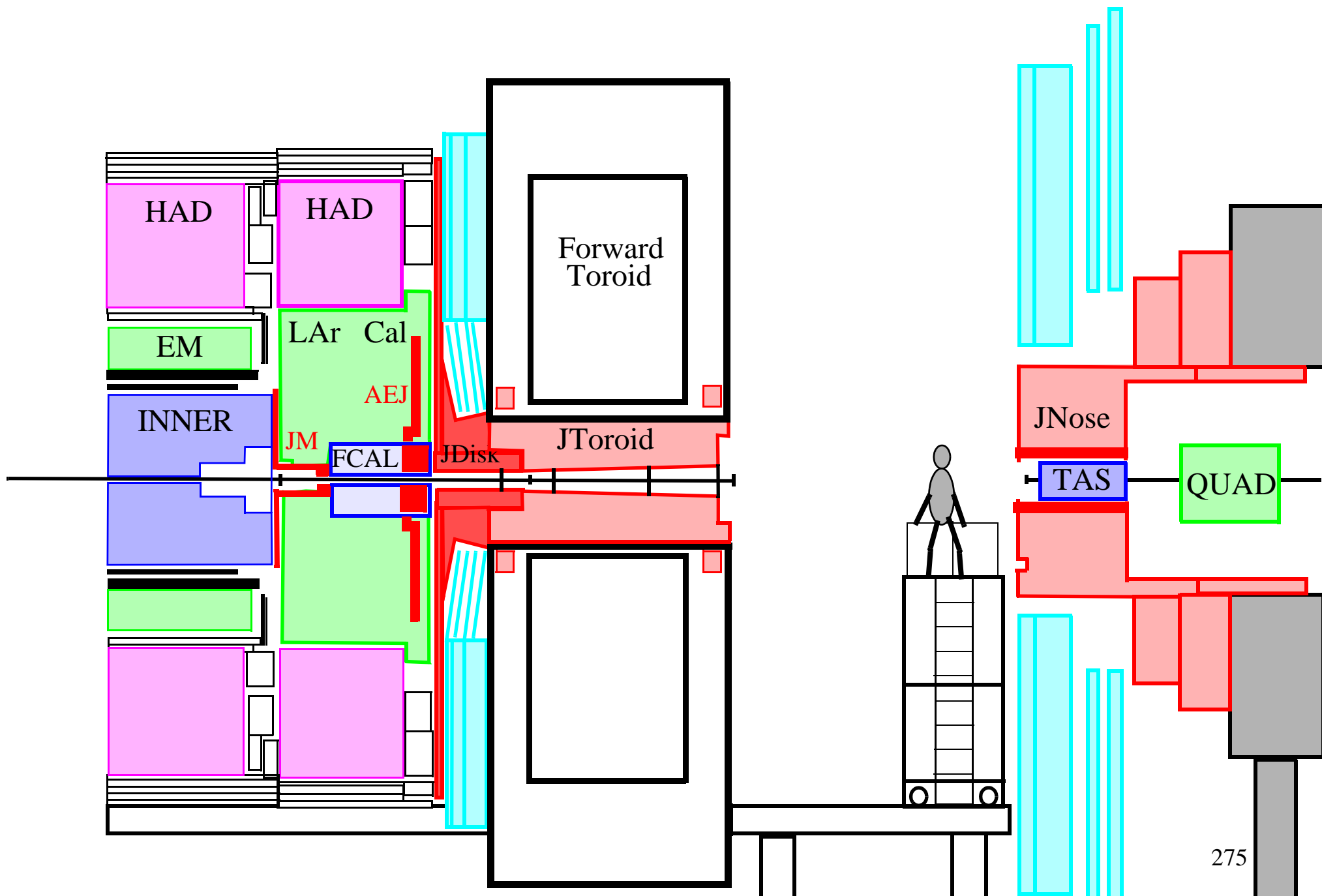

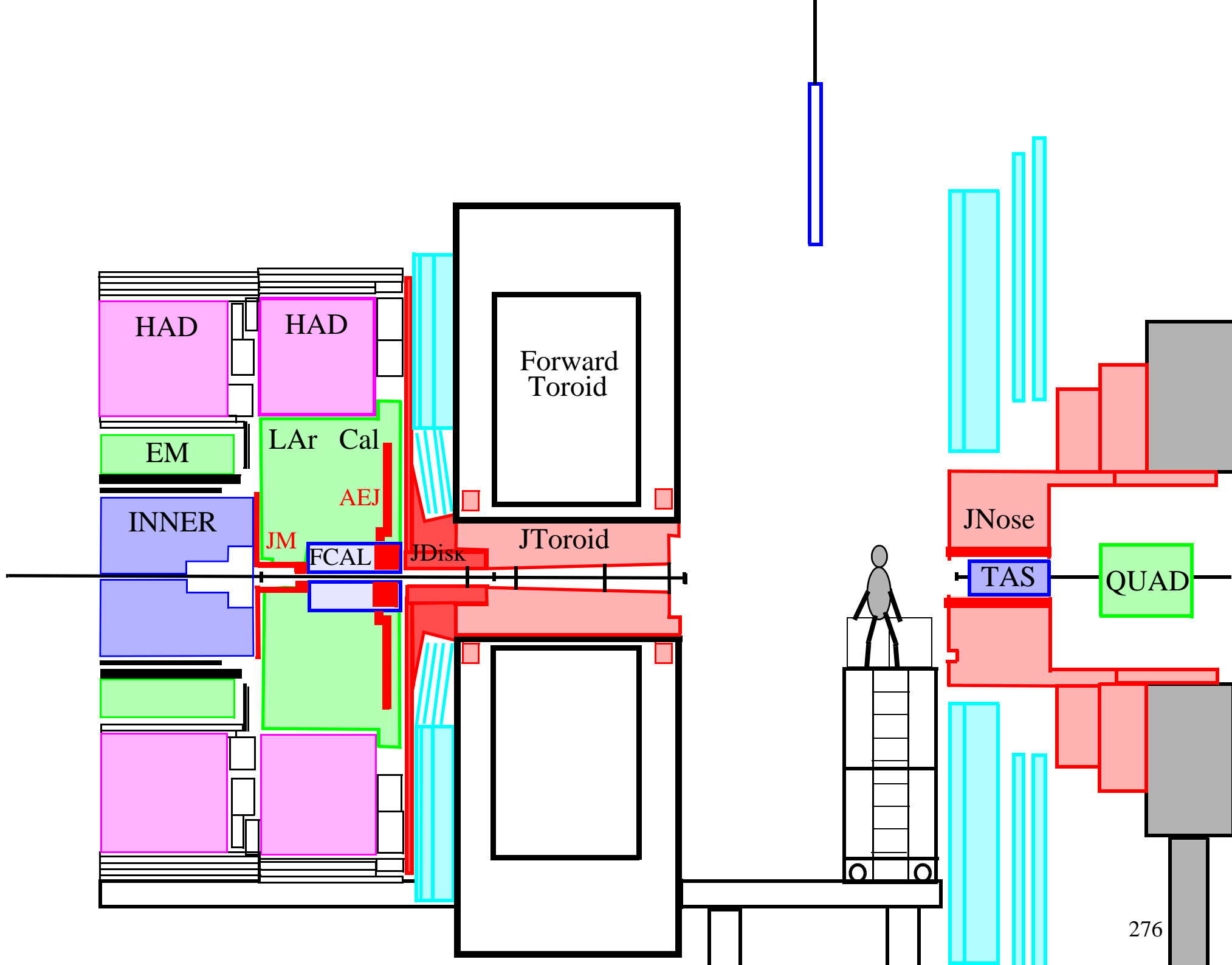

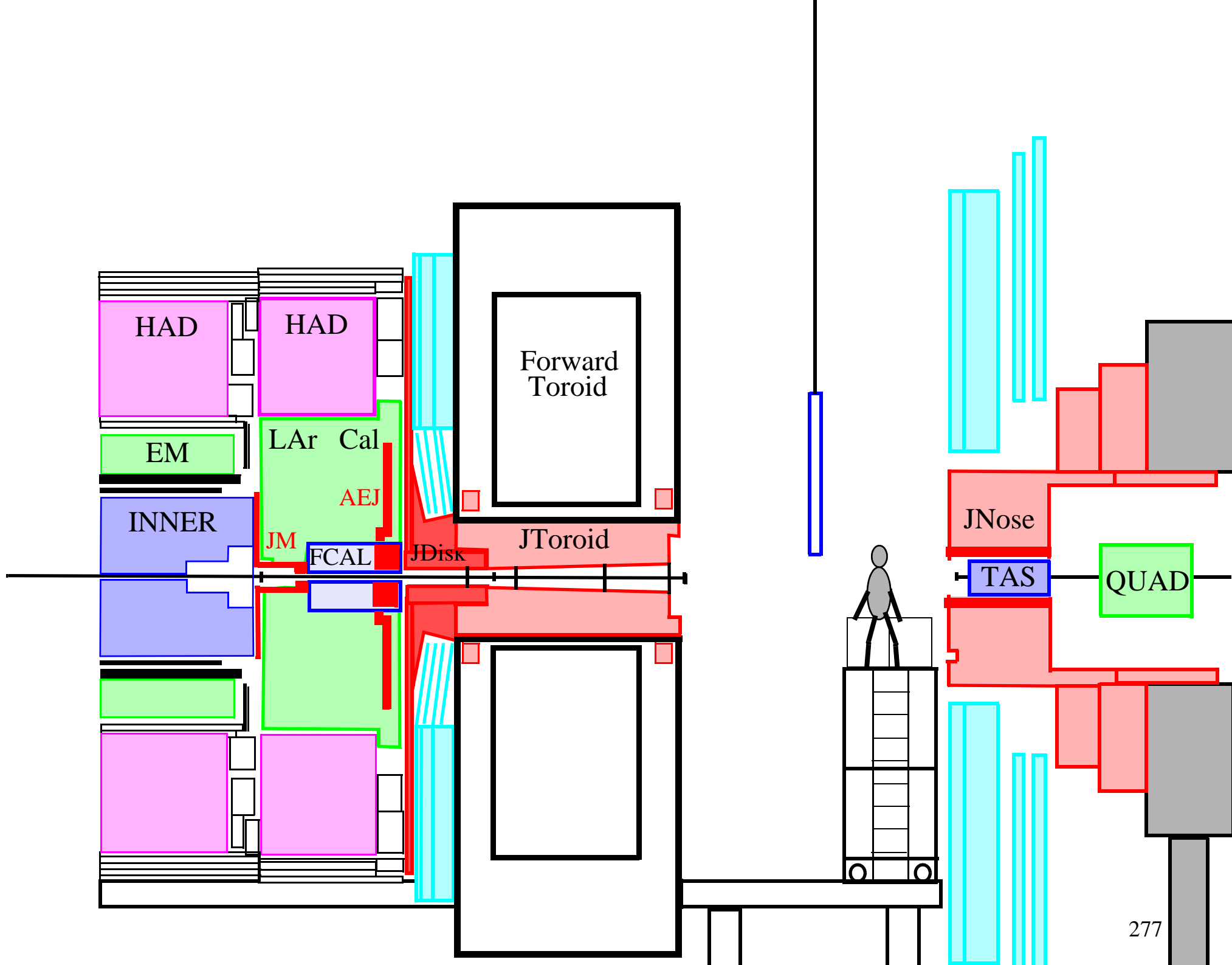

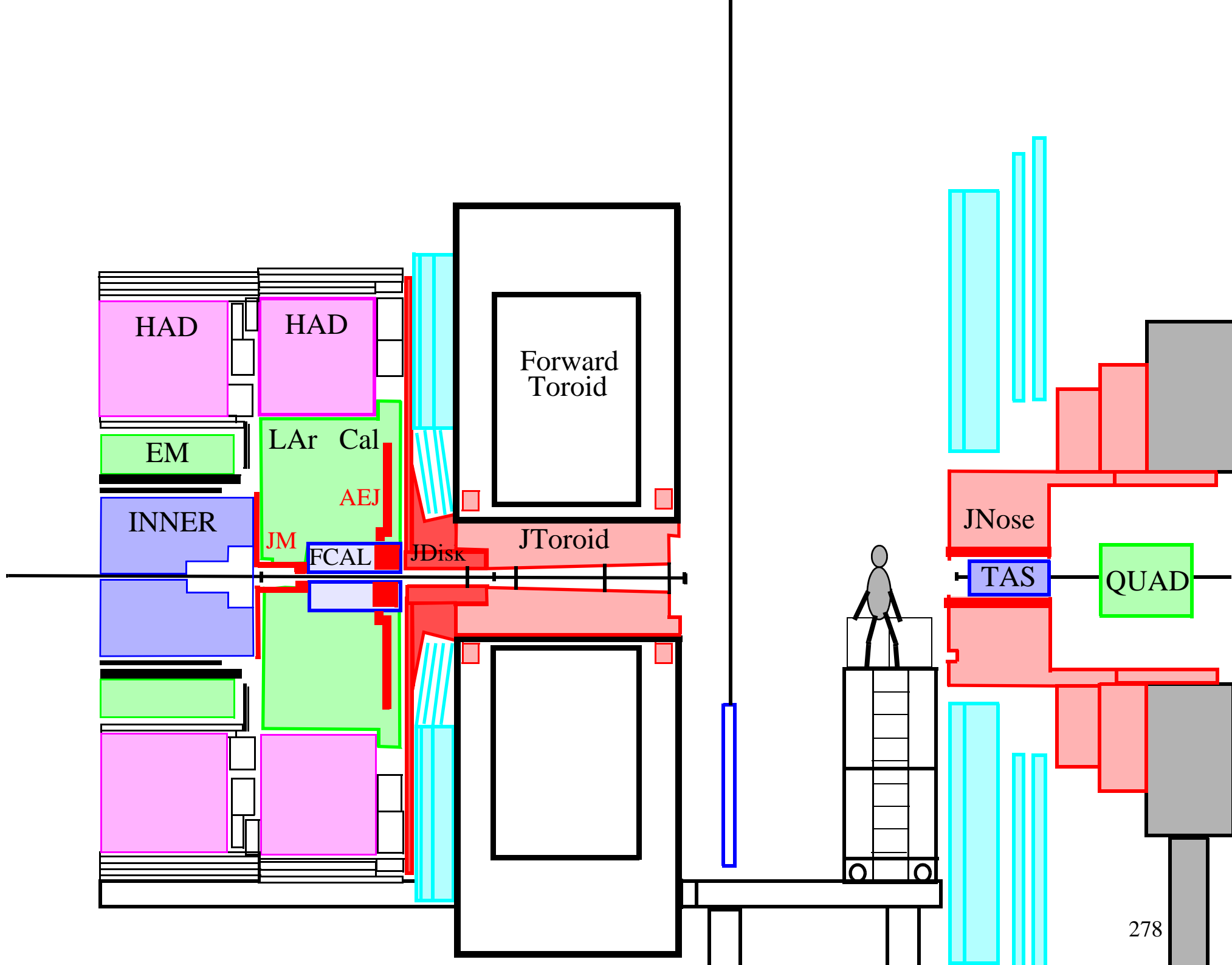

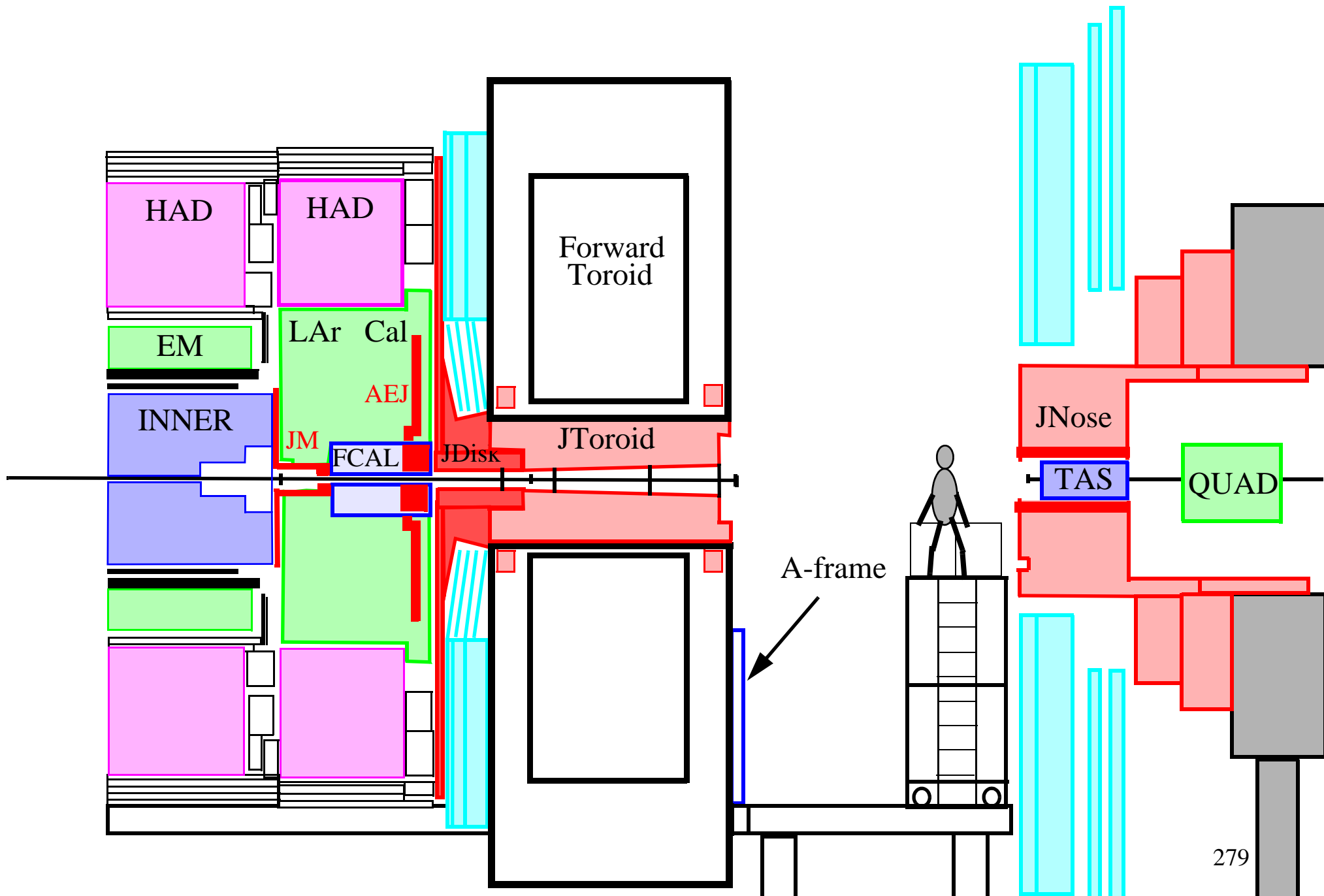

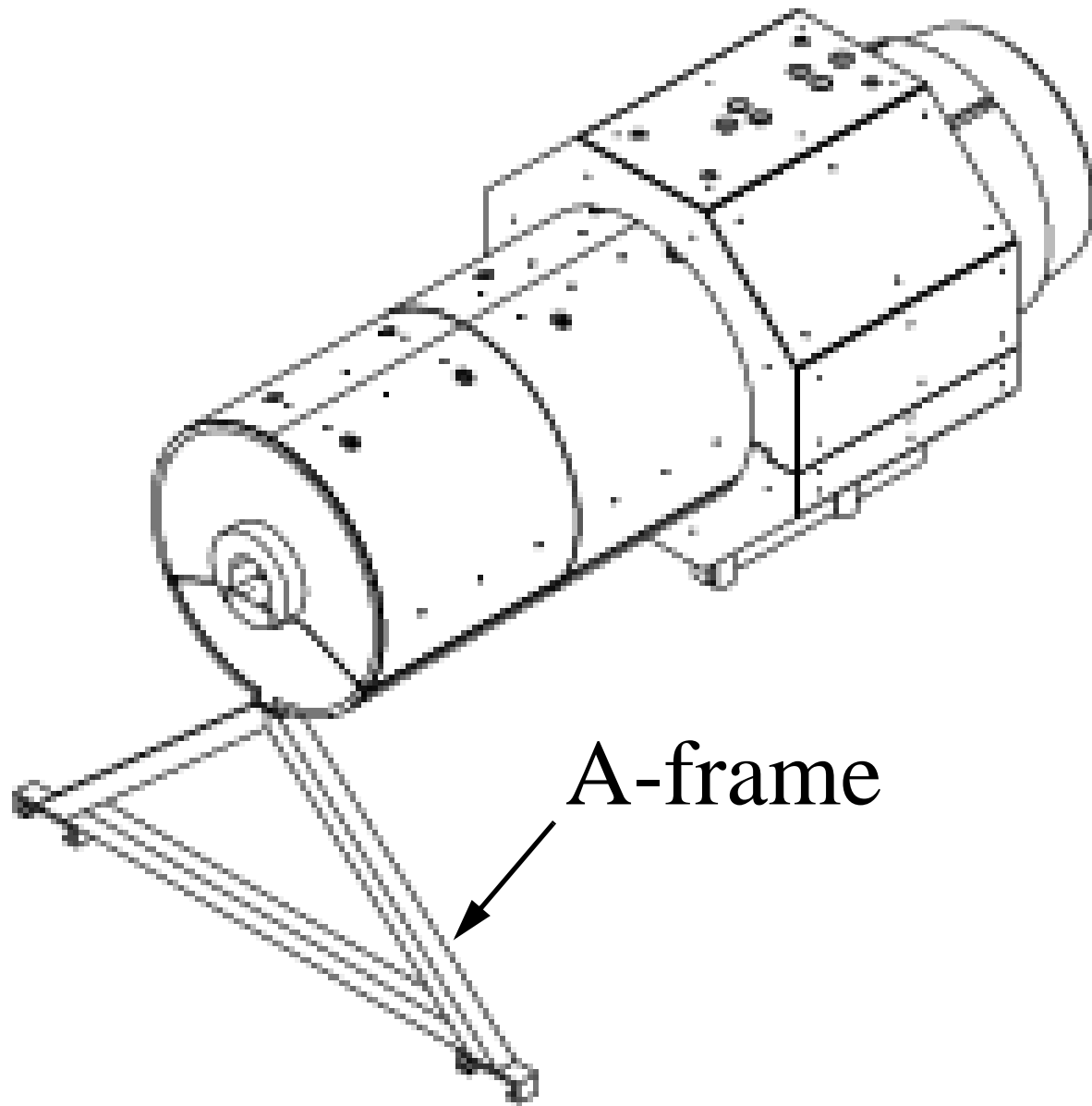

A-frame

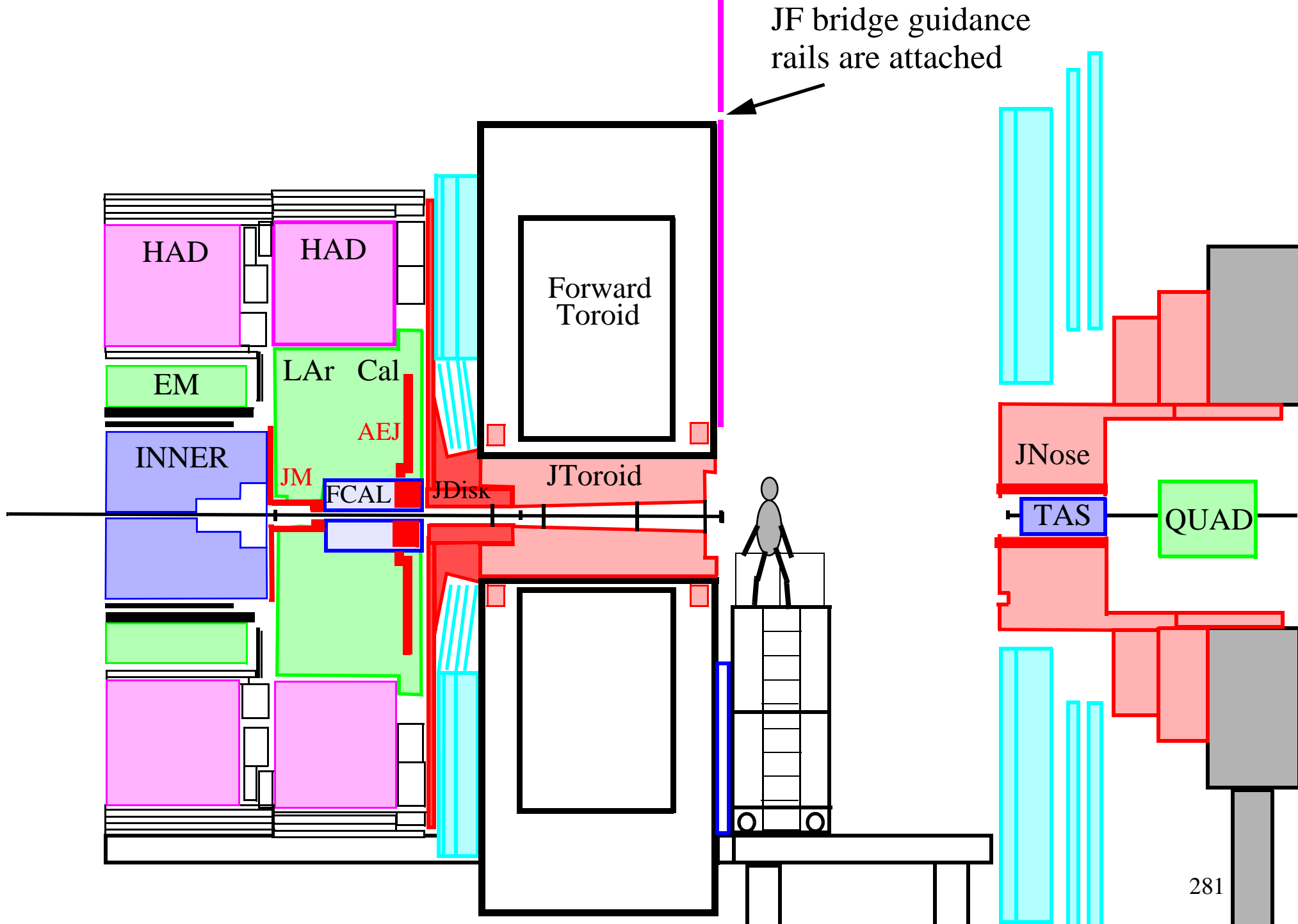

JF bridge guidance rails are attached

JF bridge guidance rails are attached to the rails above the toroid.

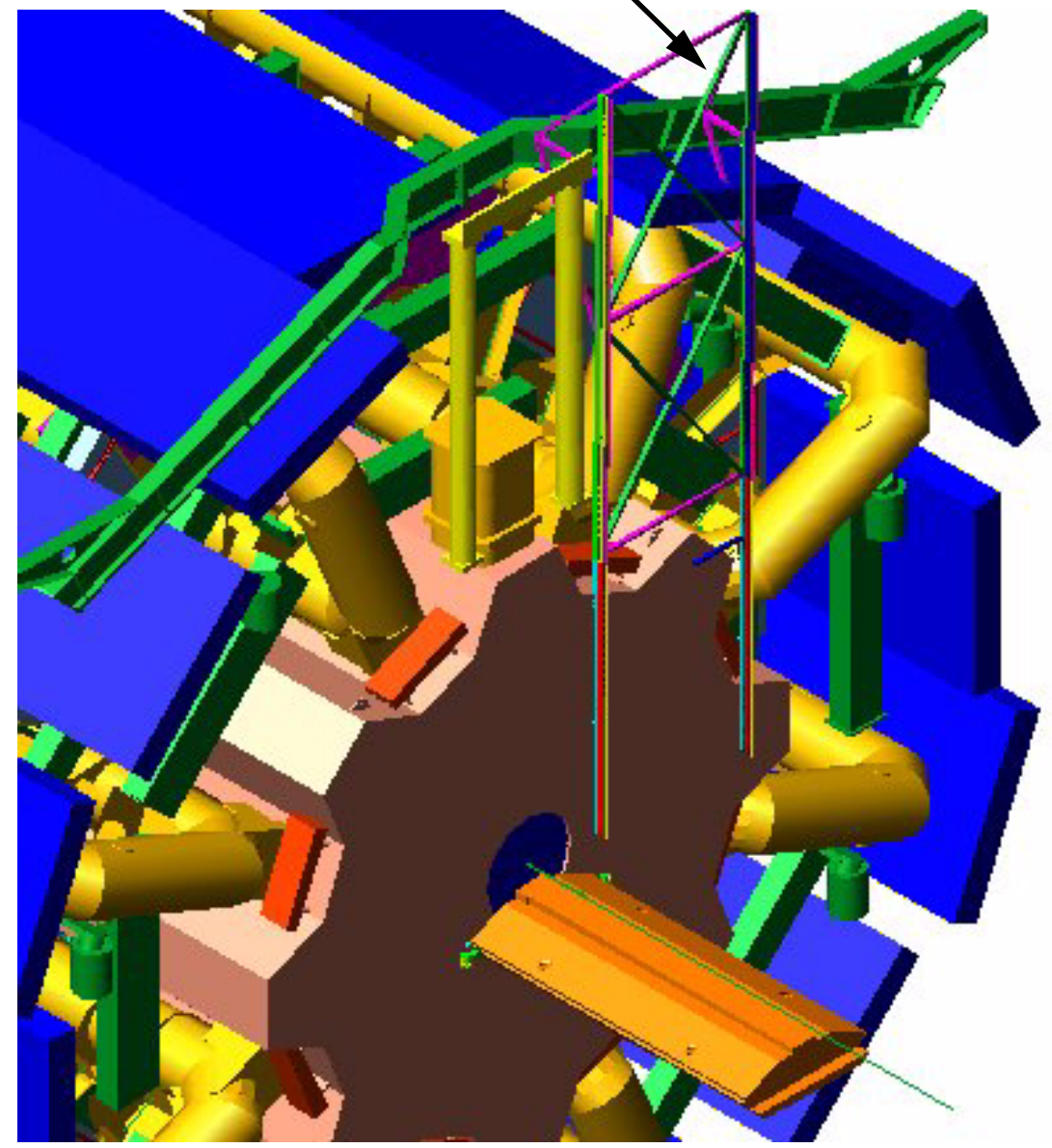
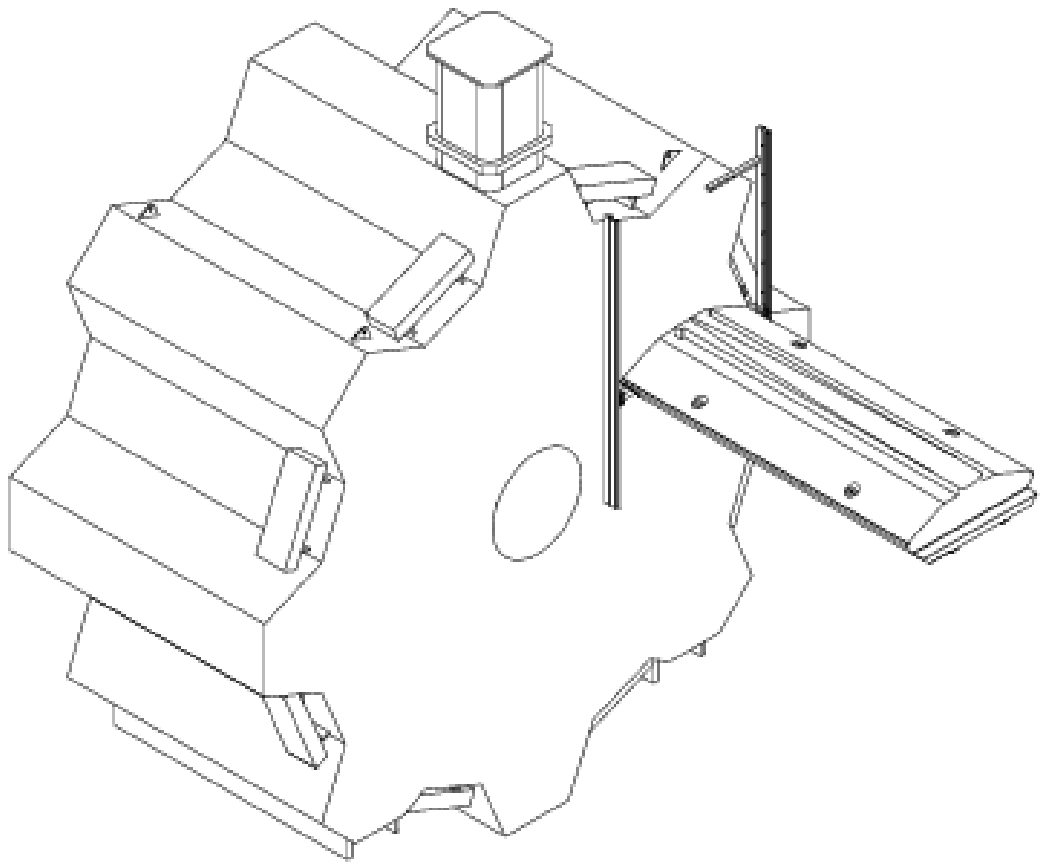

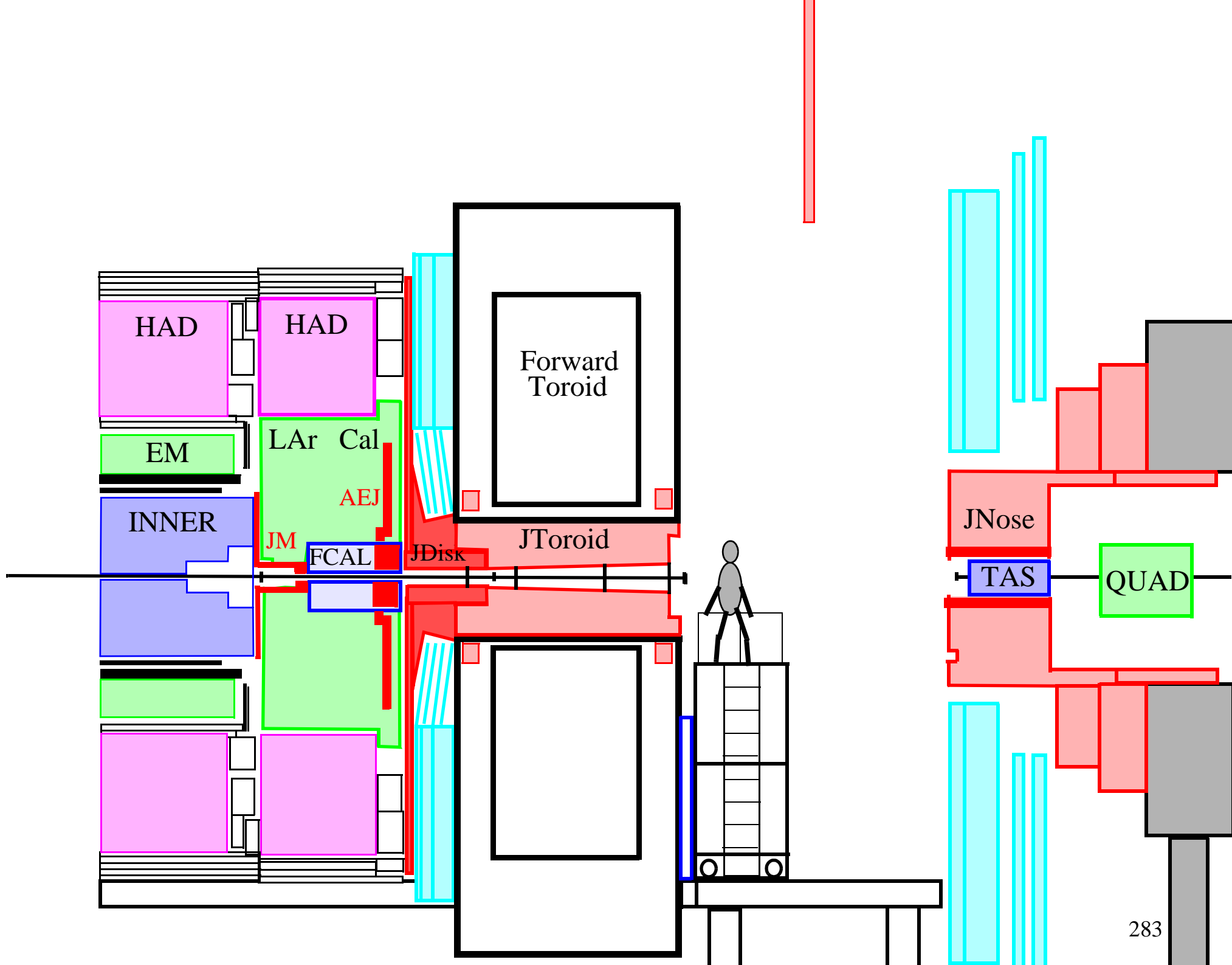

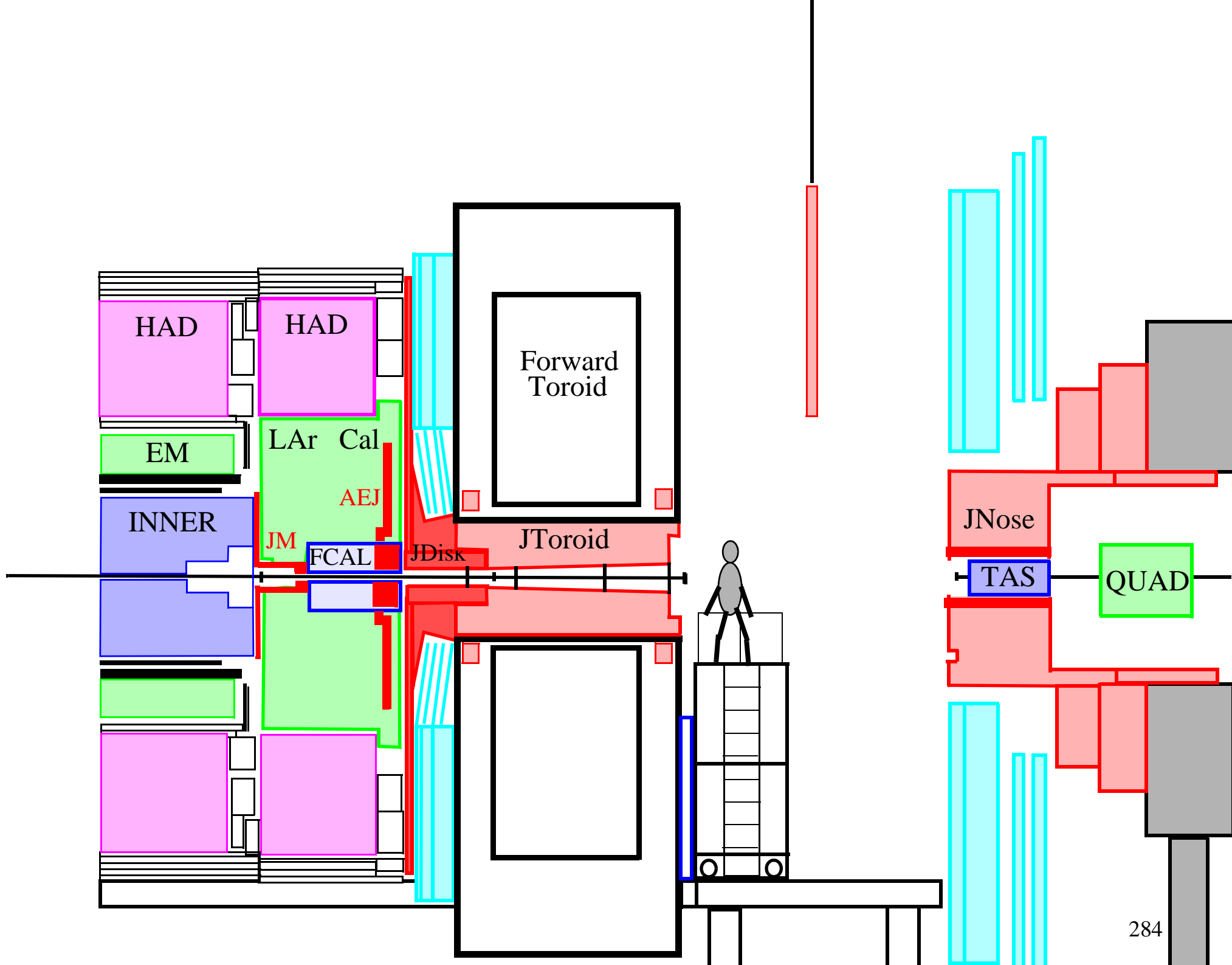

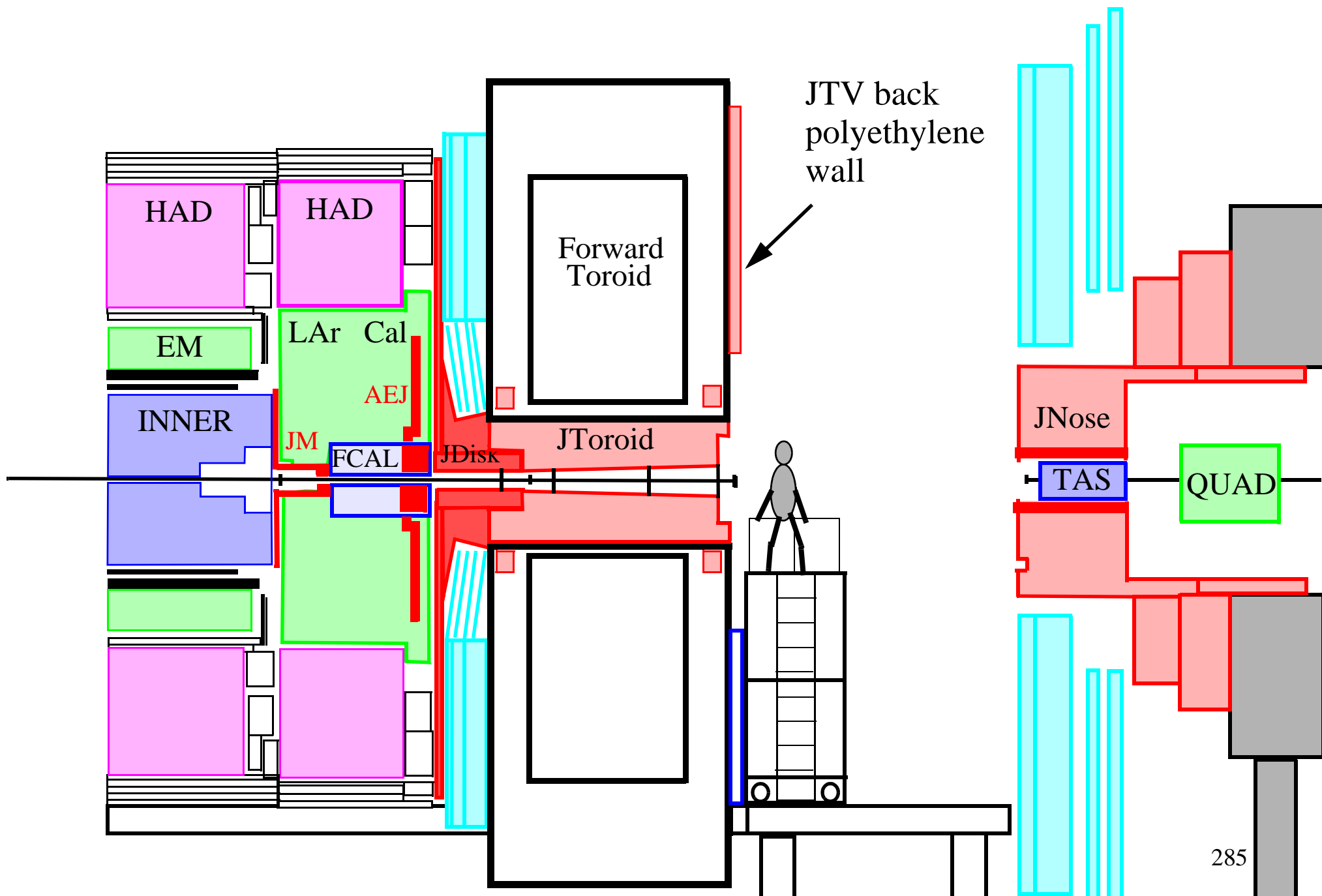

HAD

HAD

EM

LAr Cal

INNER

AEJ

JM

FCAL

JDisk

Forward
Toroid

JToroid

JTV back
polyethylene
wall

JNose

TAS

QUAD

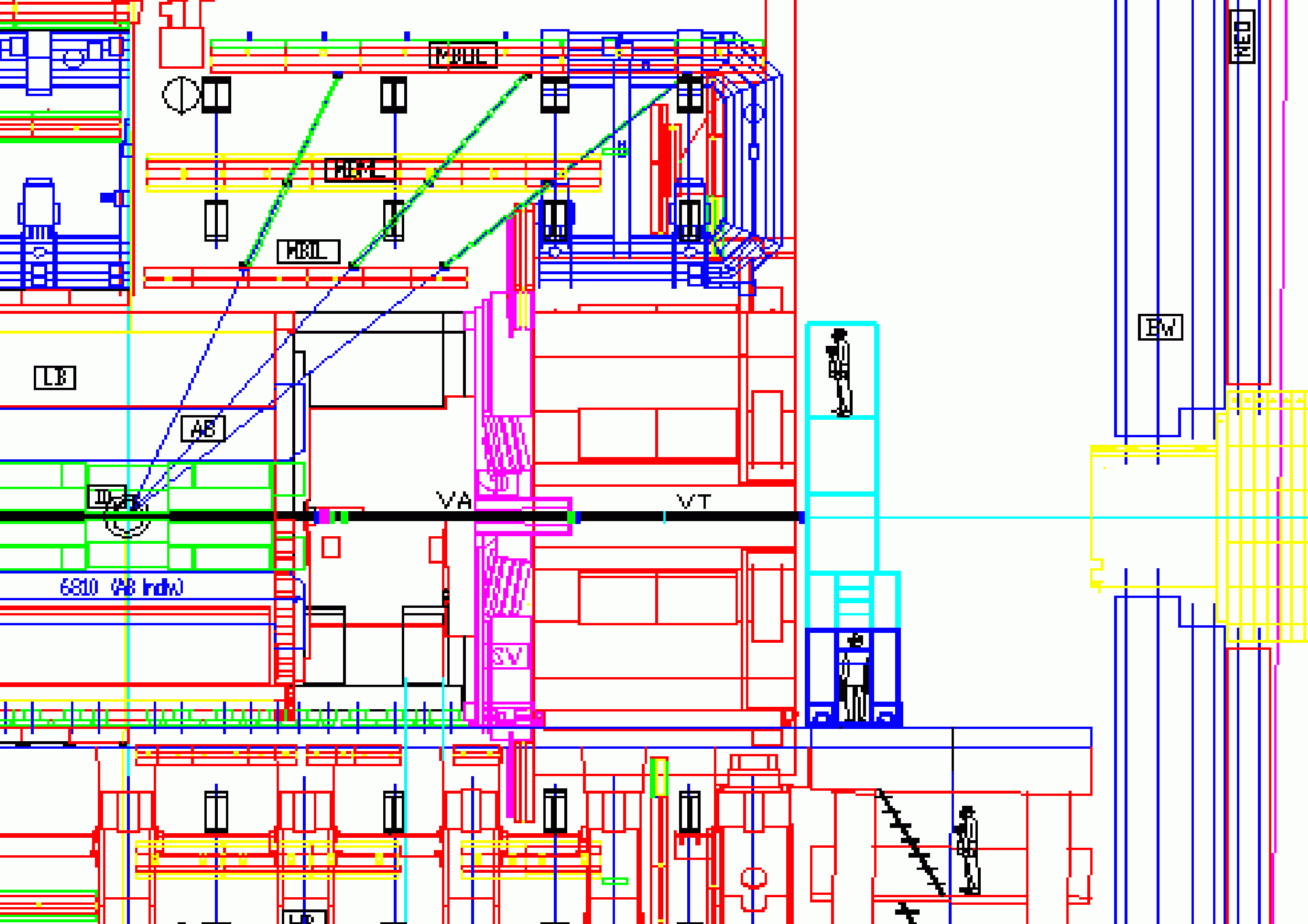

POST

POST

POST

LE

AB

ID

VA

VT

3V

BW

MED

6810 (AB Indiv)

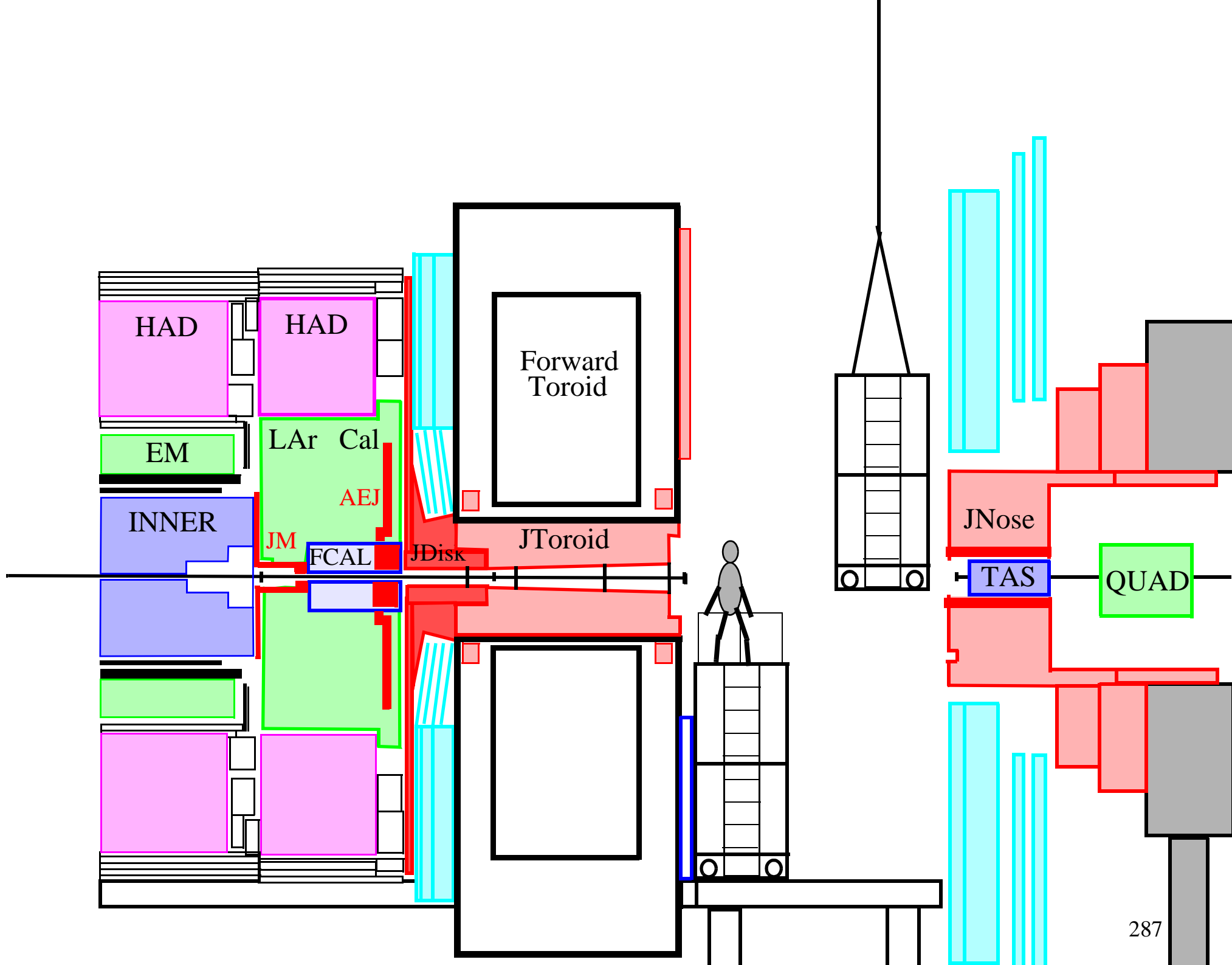

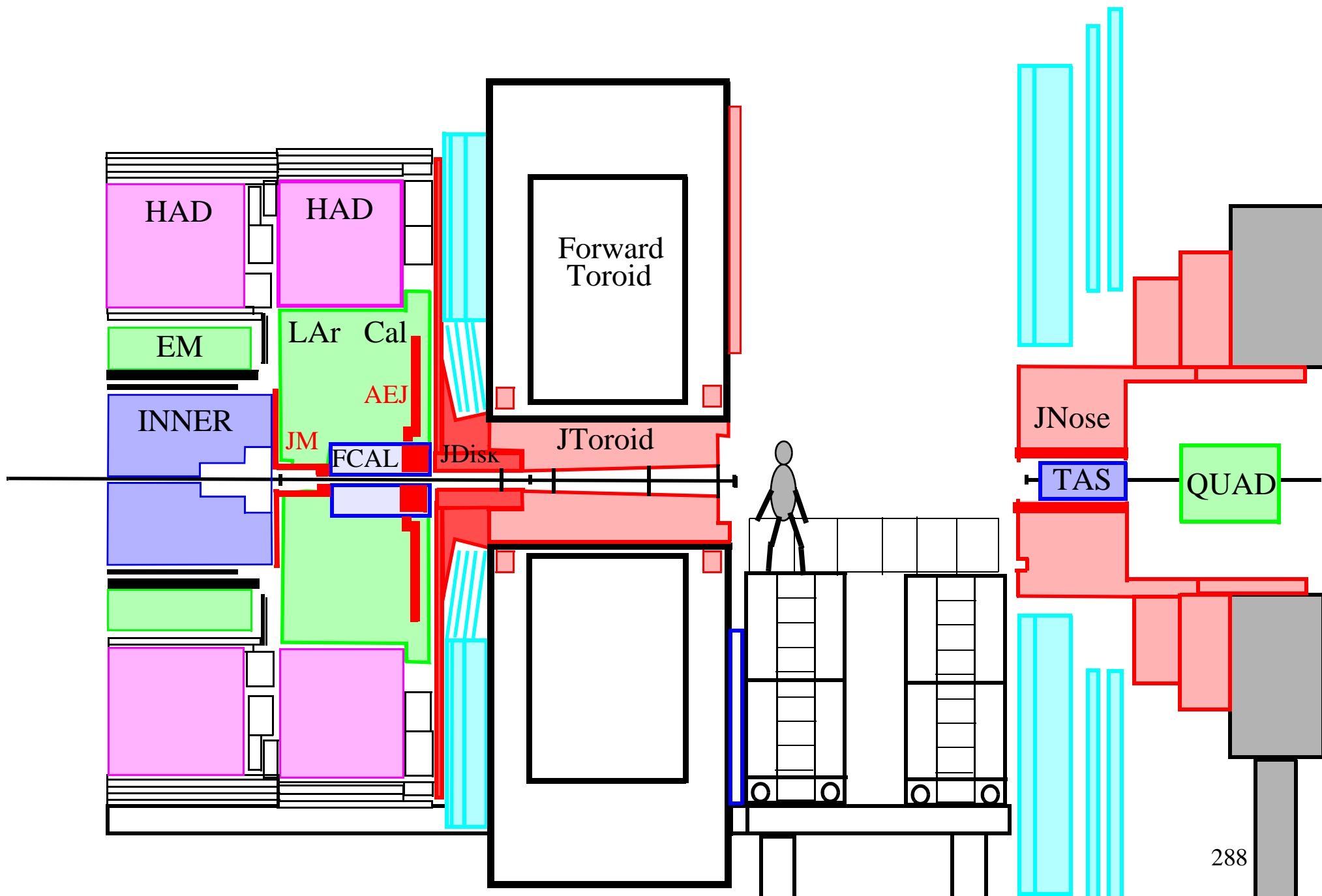

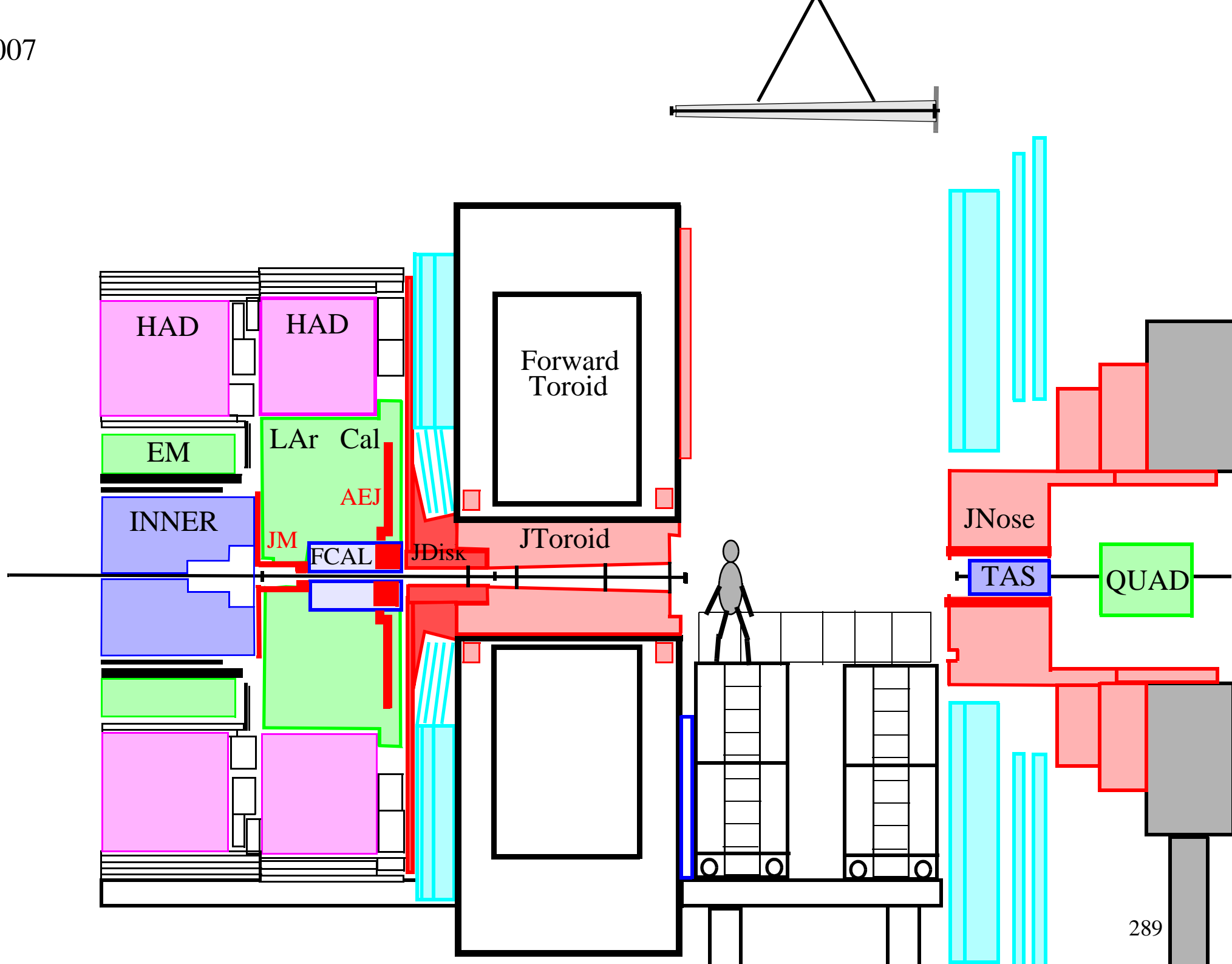

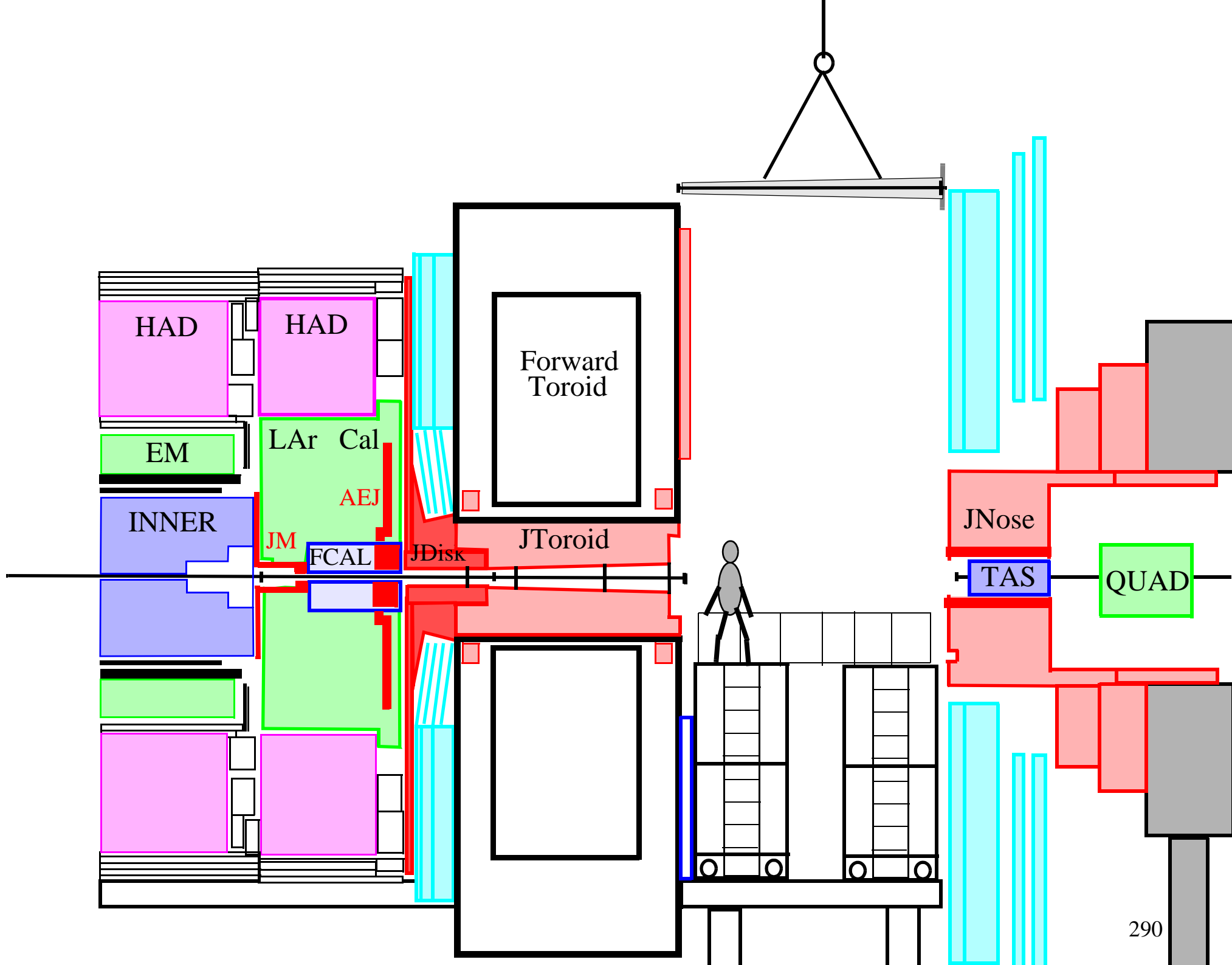

HAD

HAD

Forward
Toroid

EM

LAr Cal

INNER

AEJ

JToroid

JM

FCAL

JDisk

JNose

TAS

QUAD

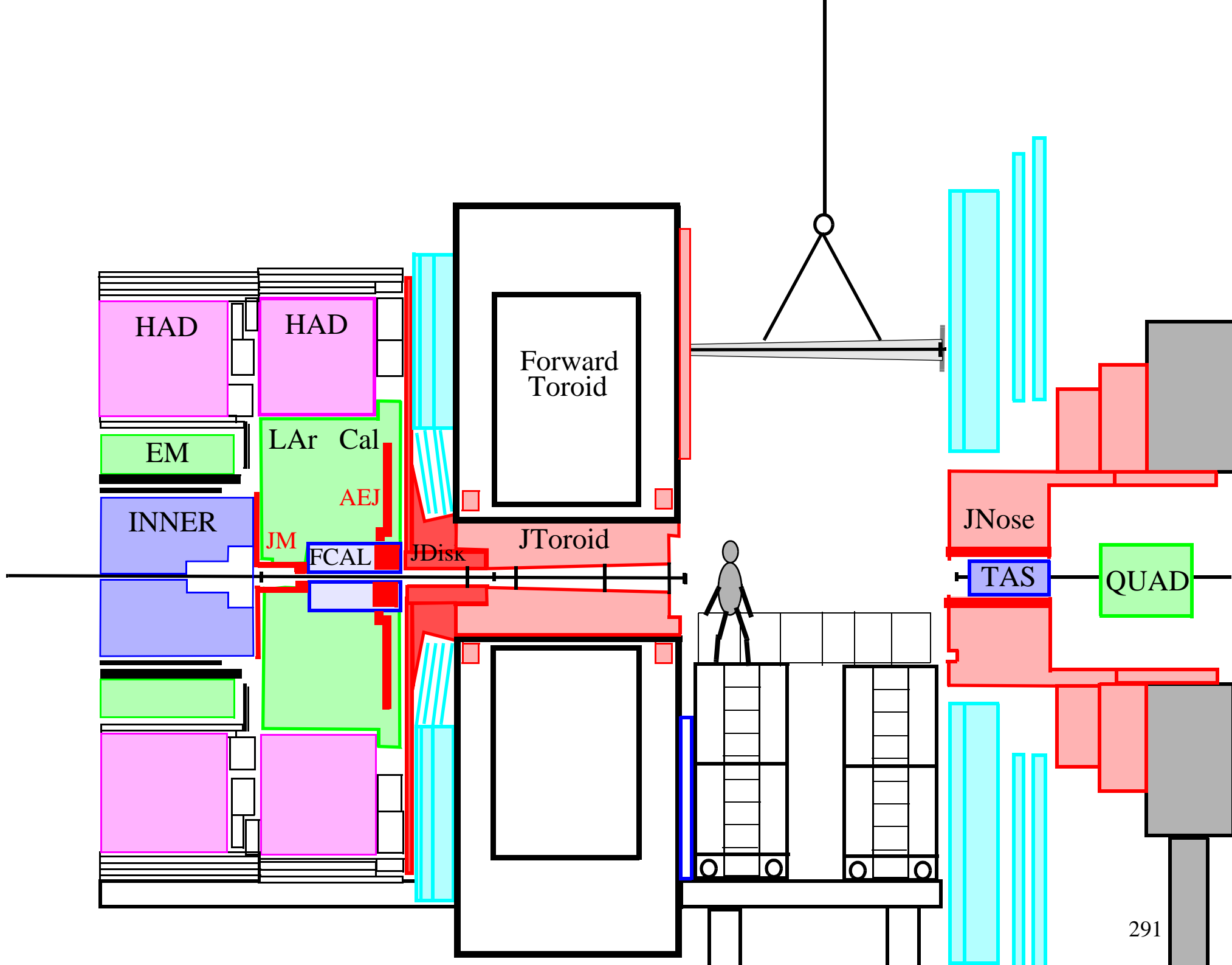

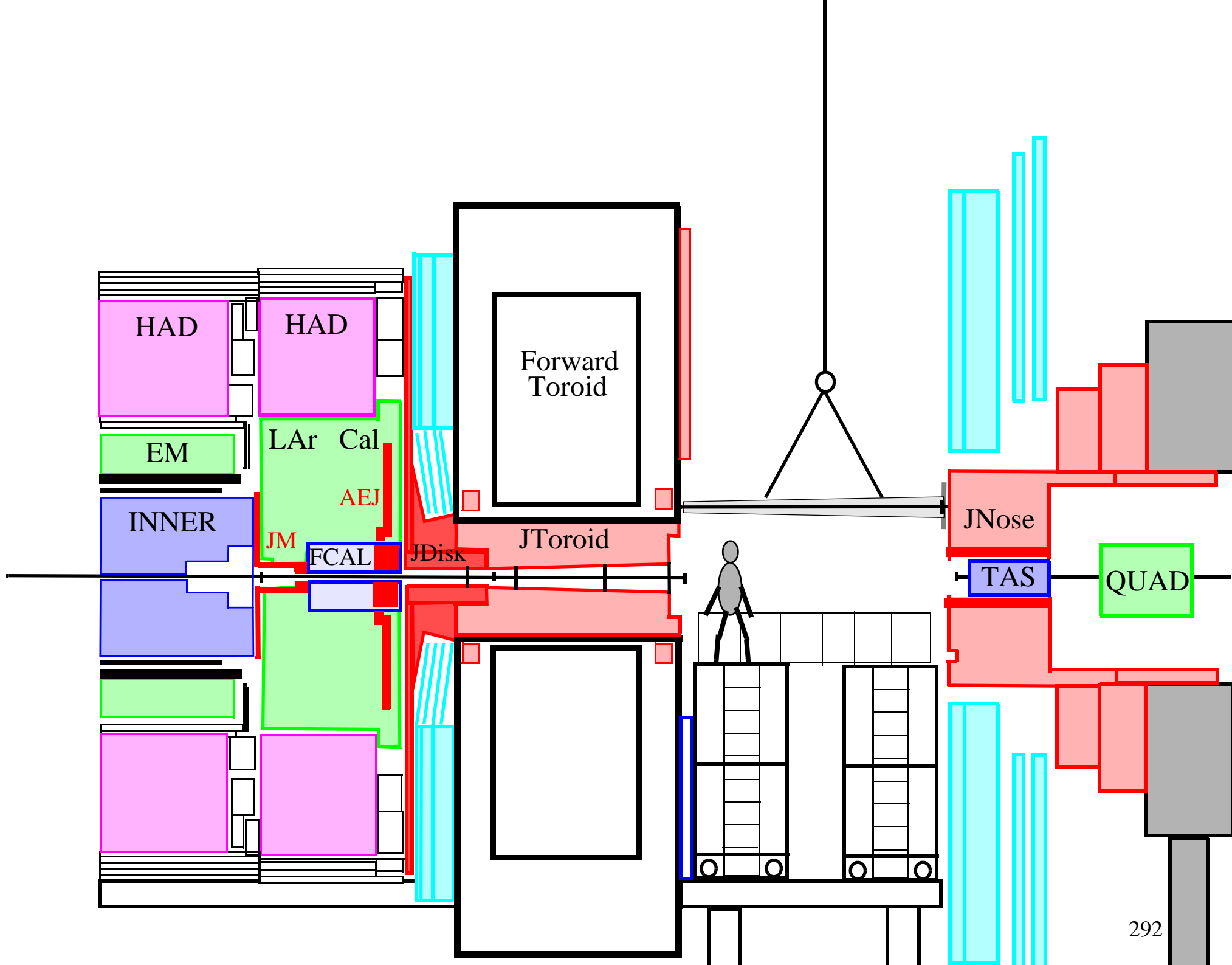

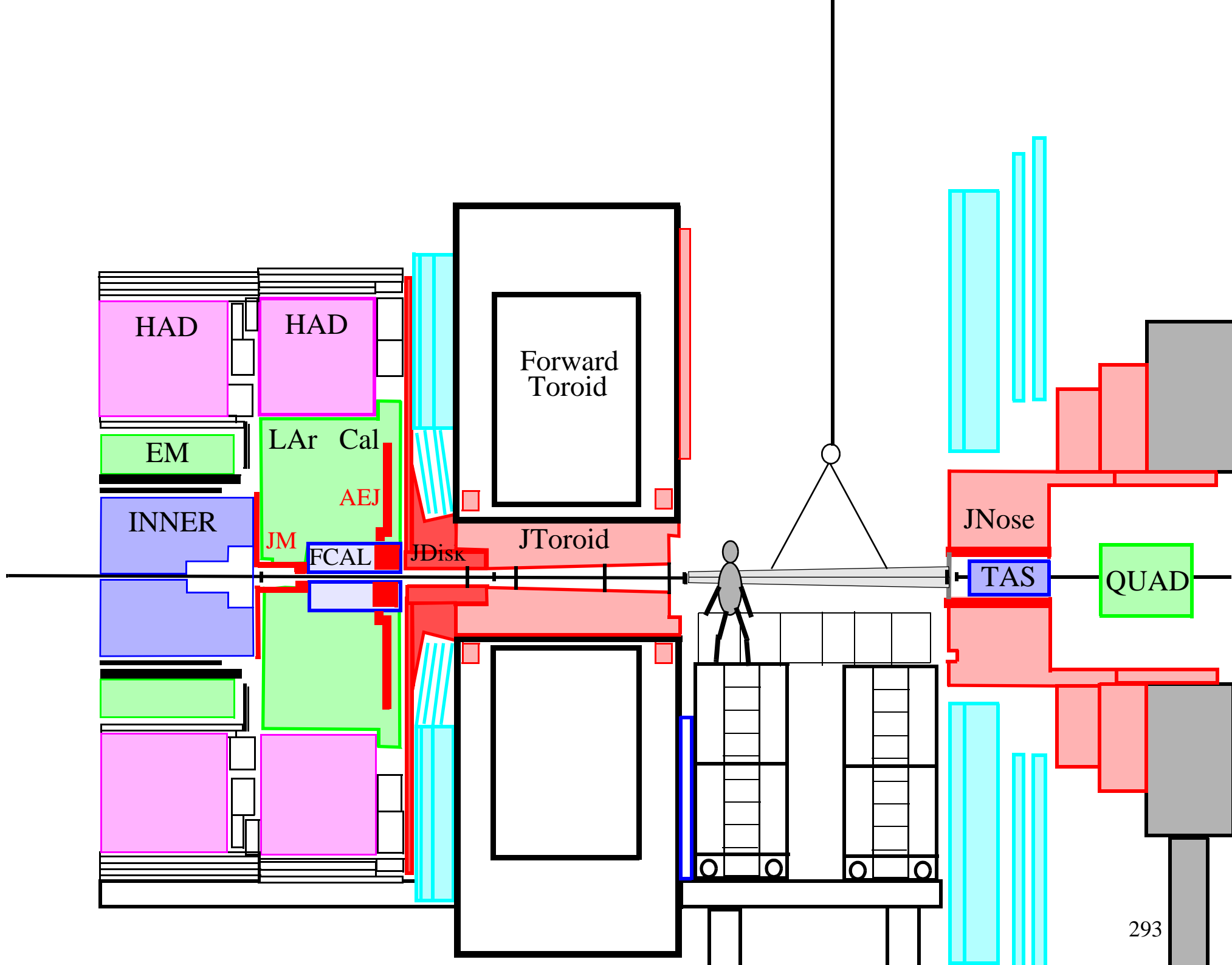

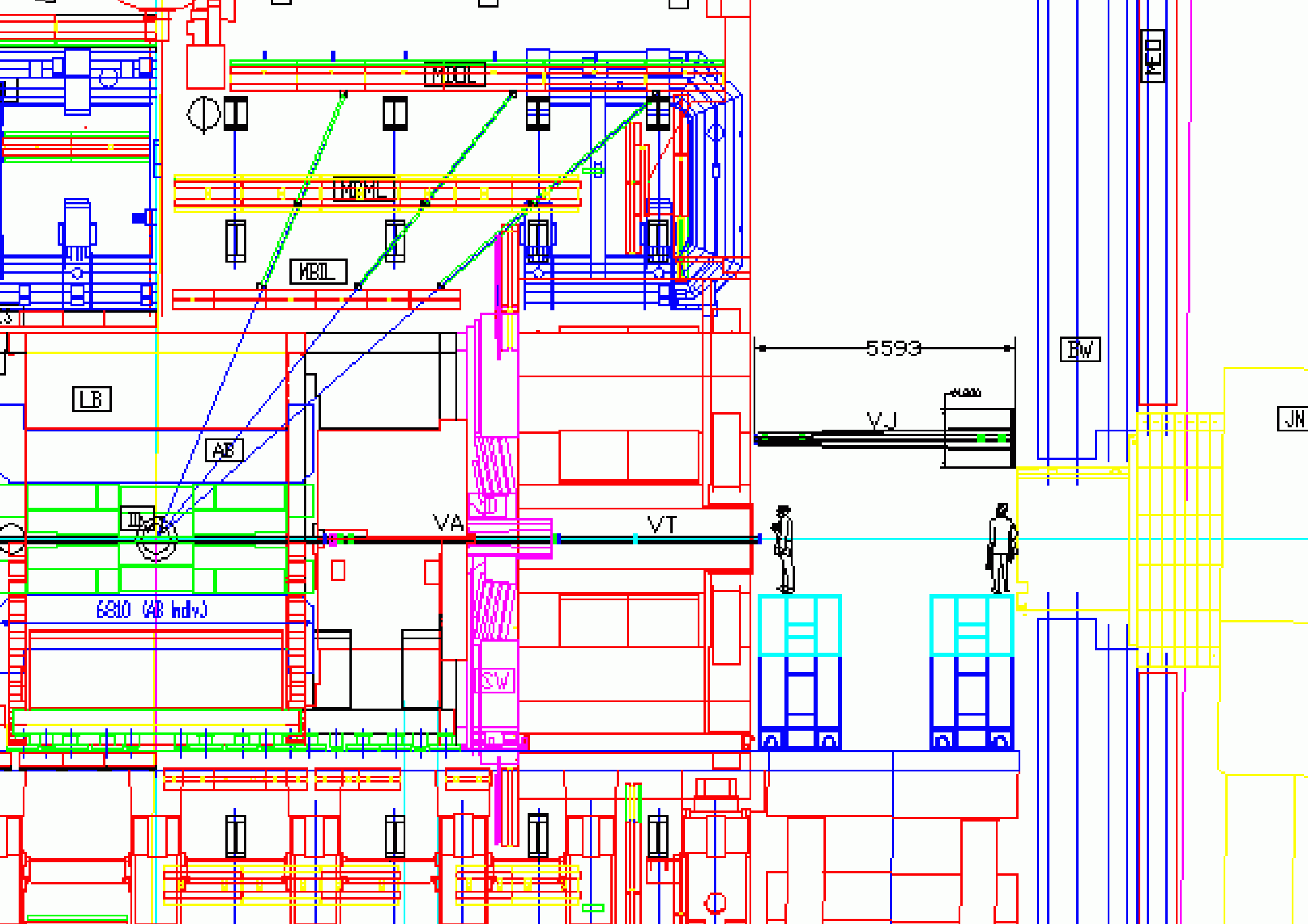

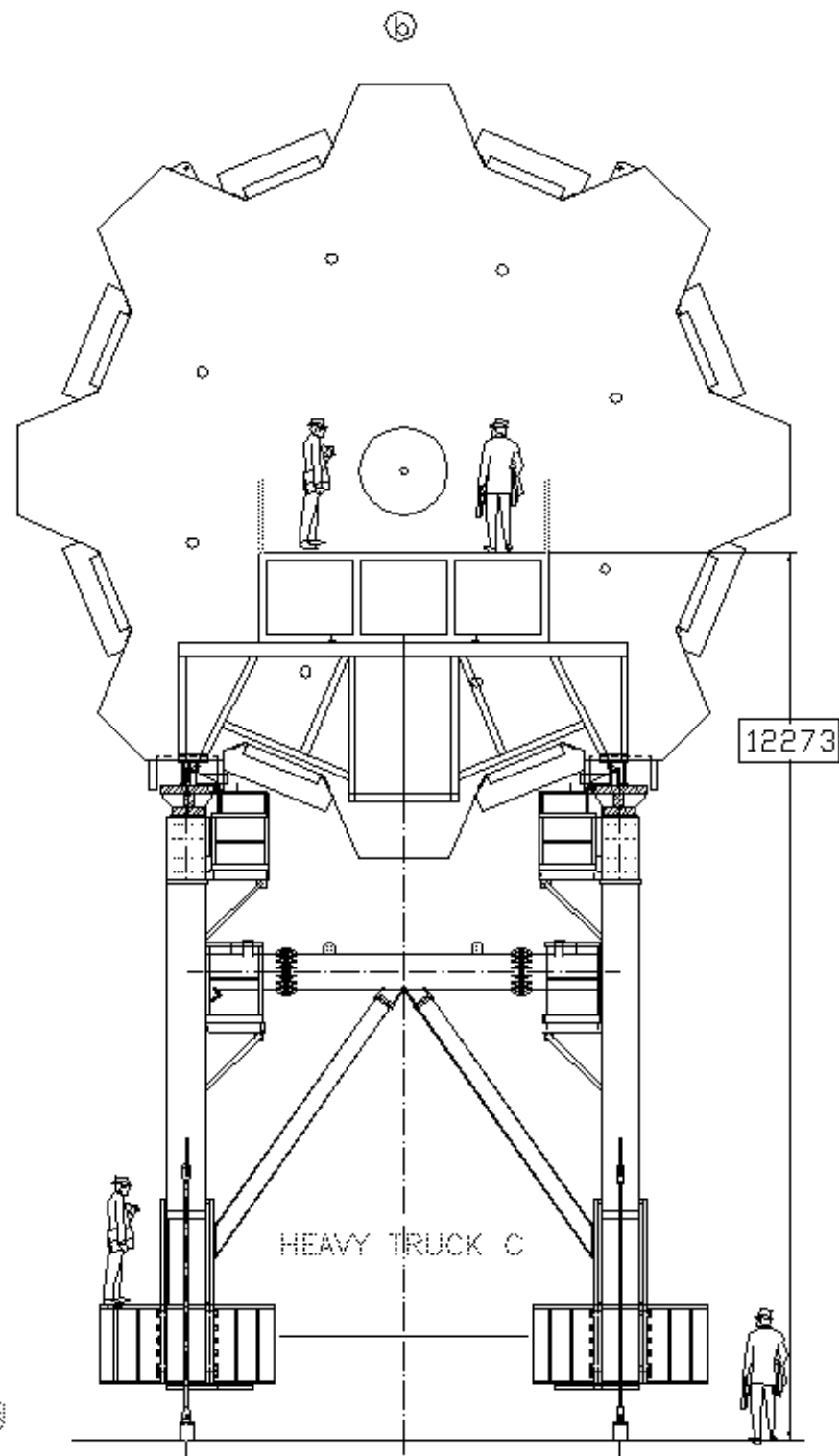

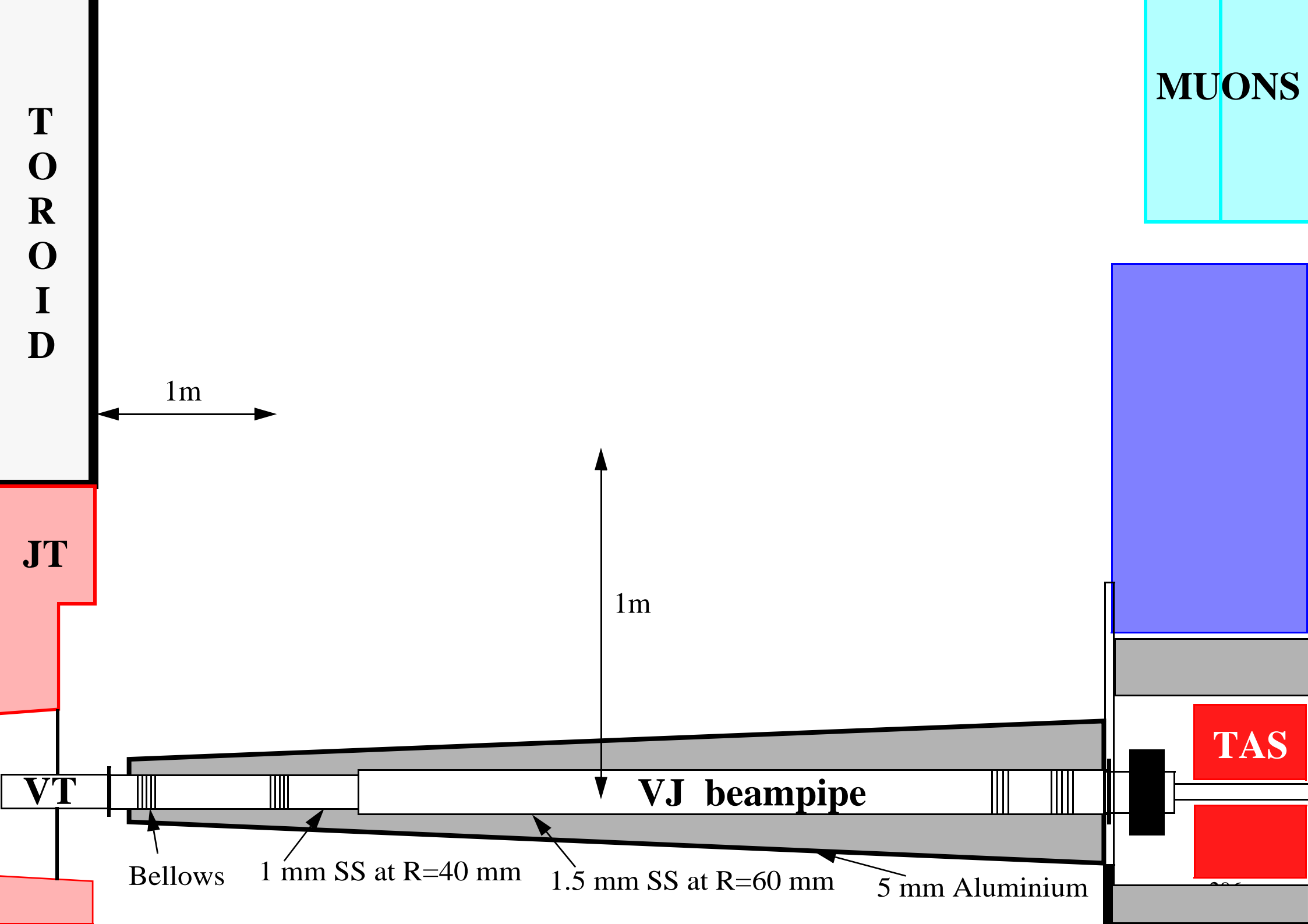

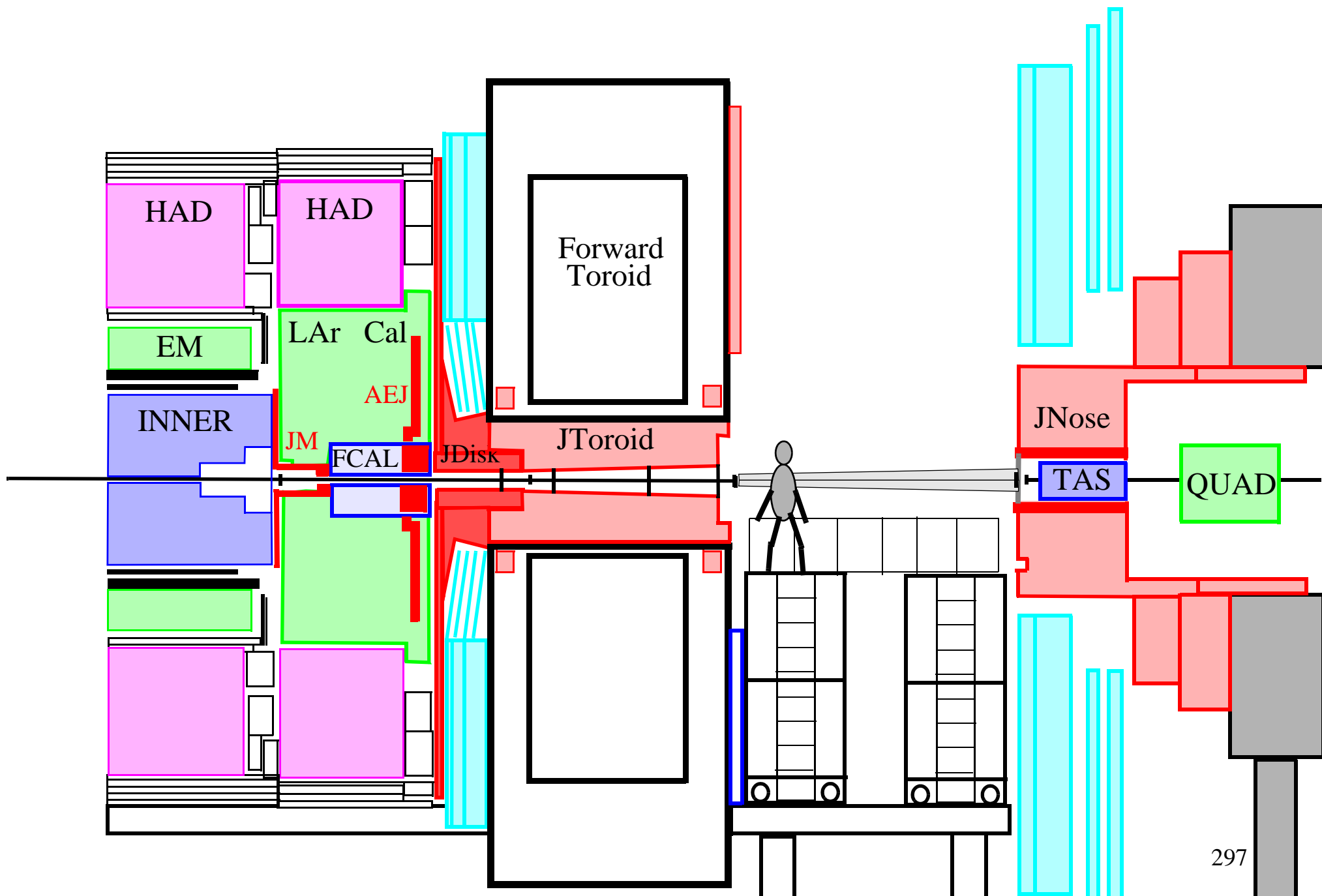

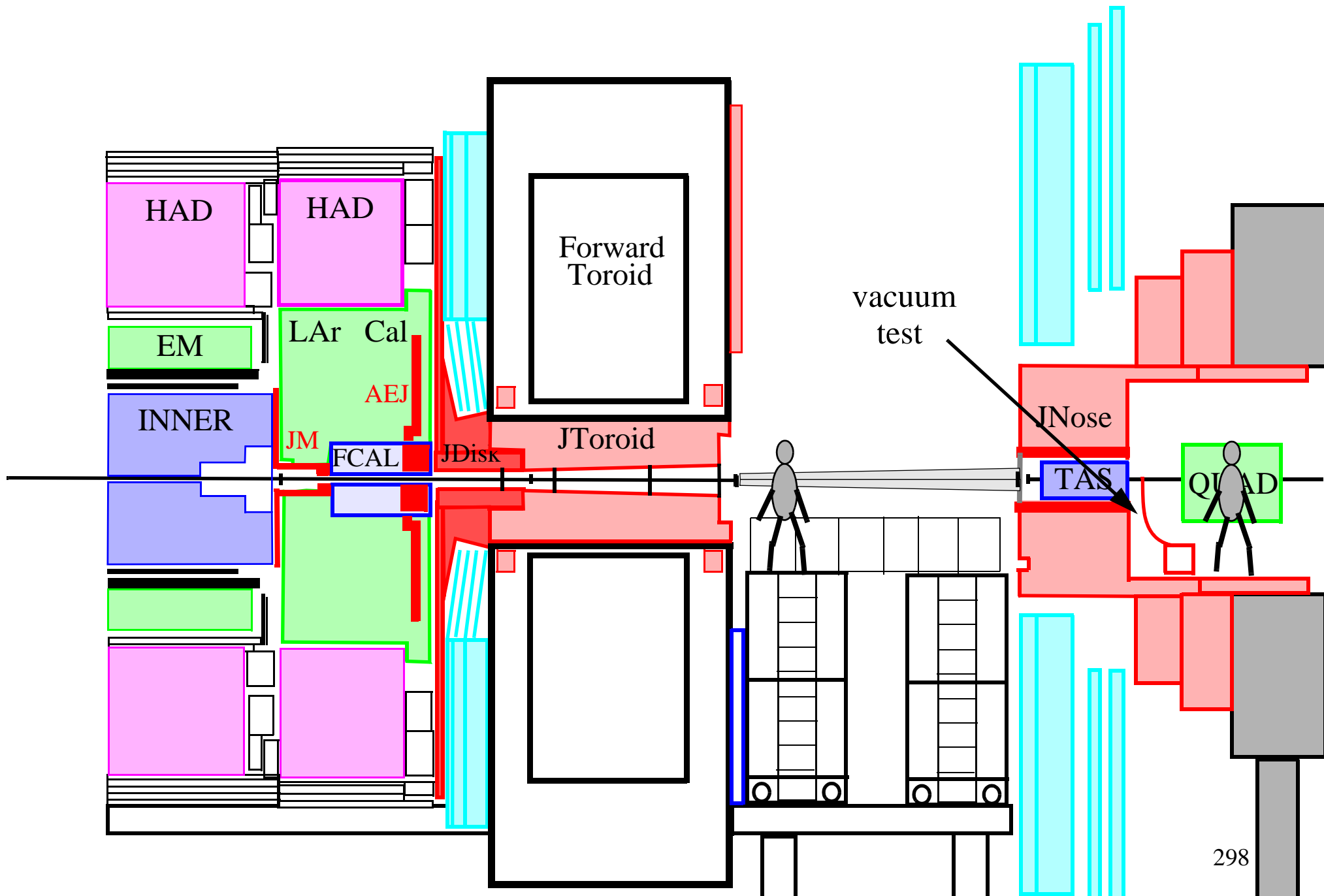

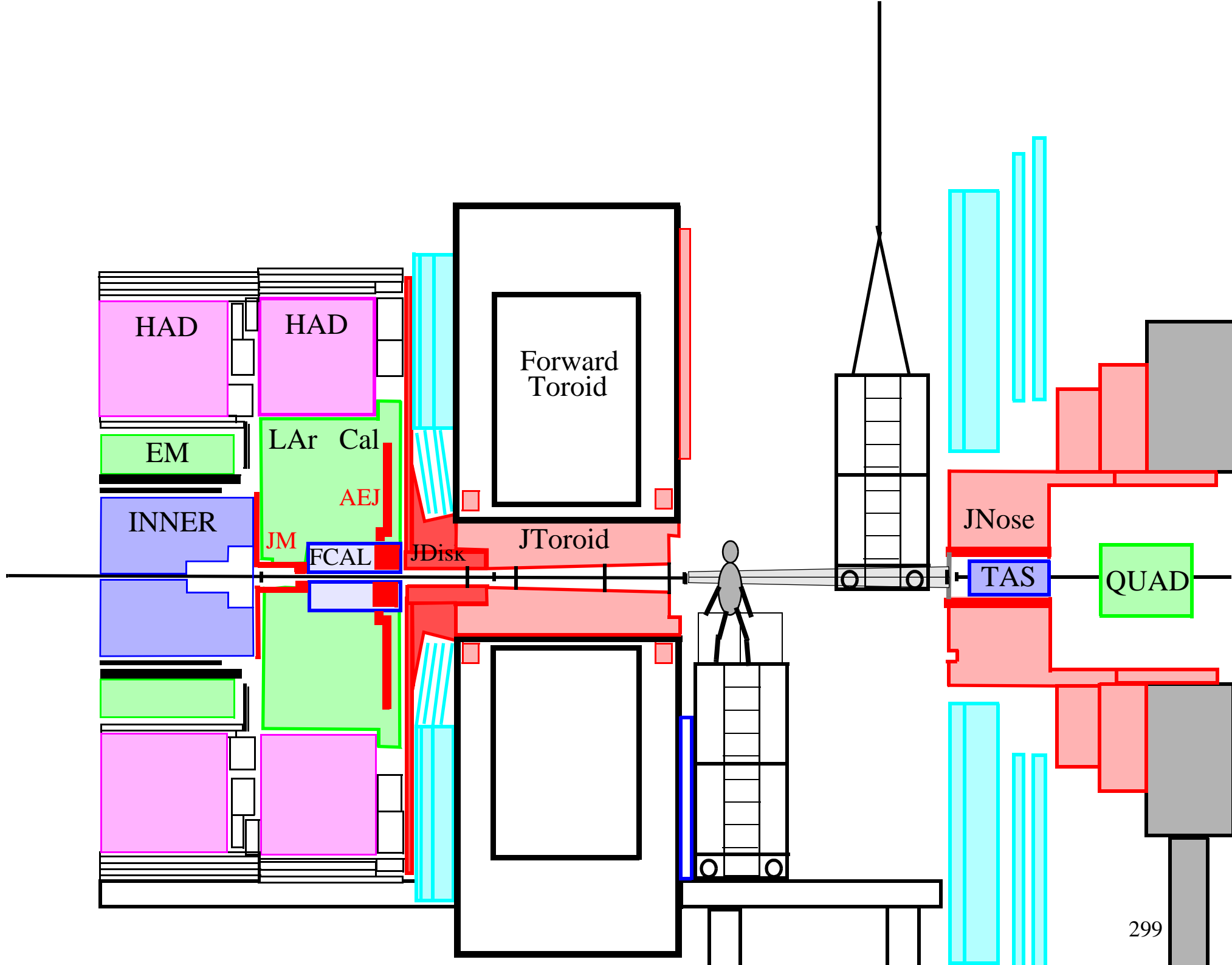

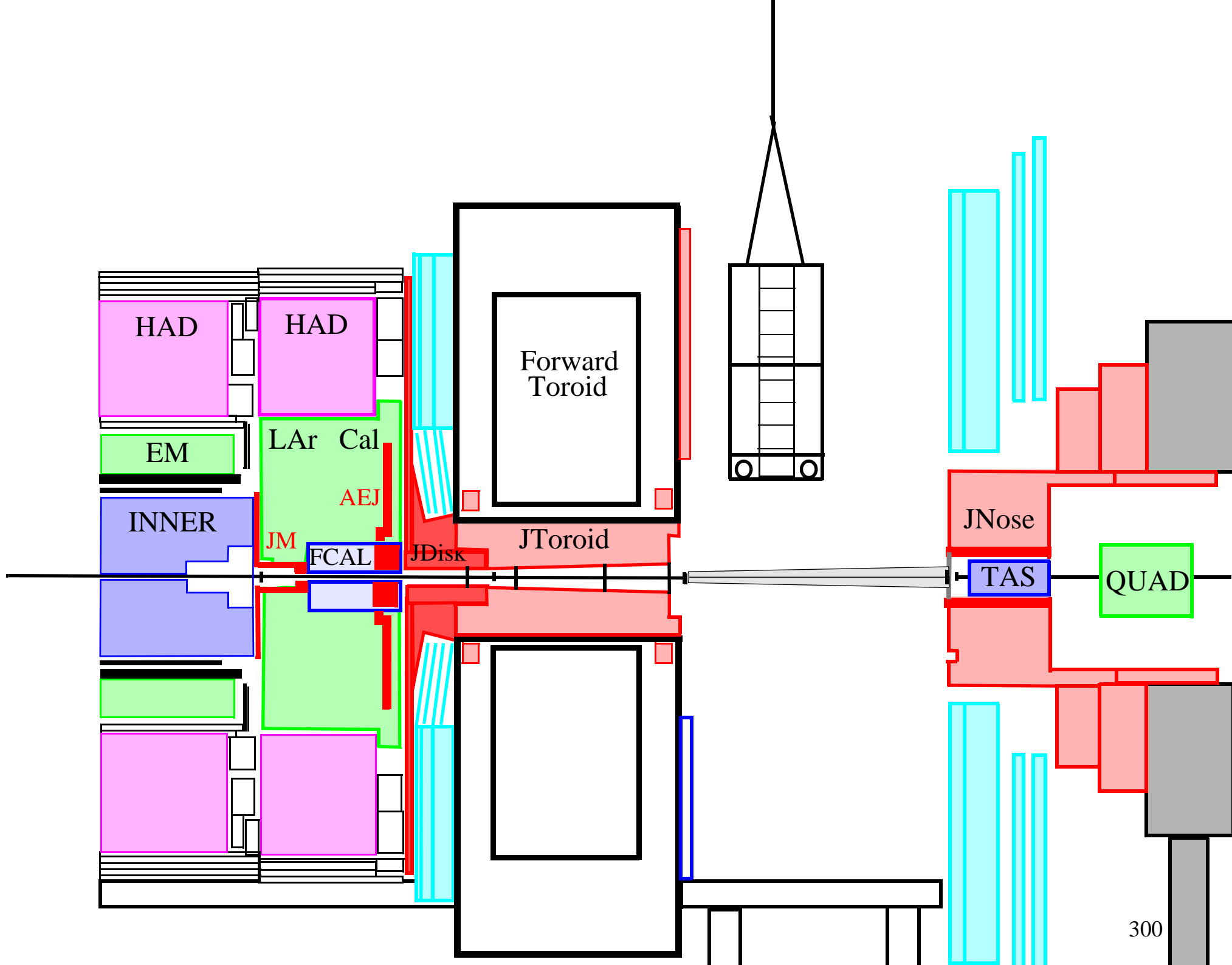

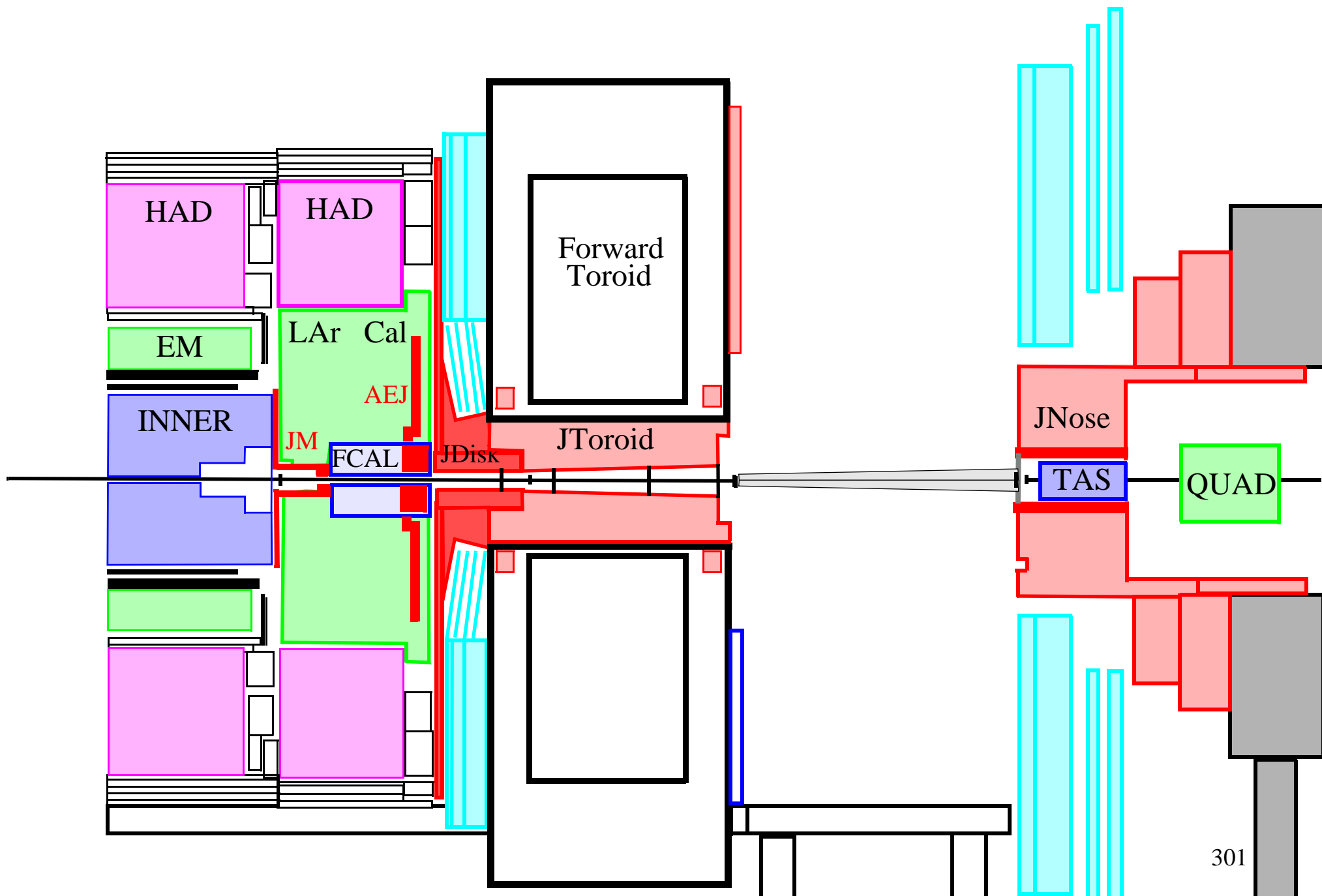

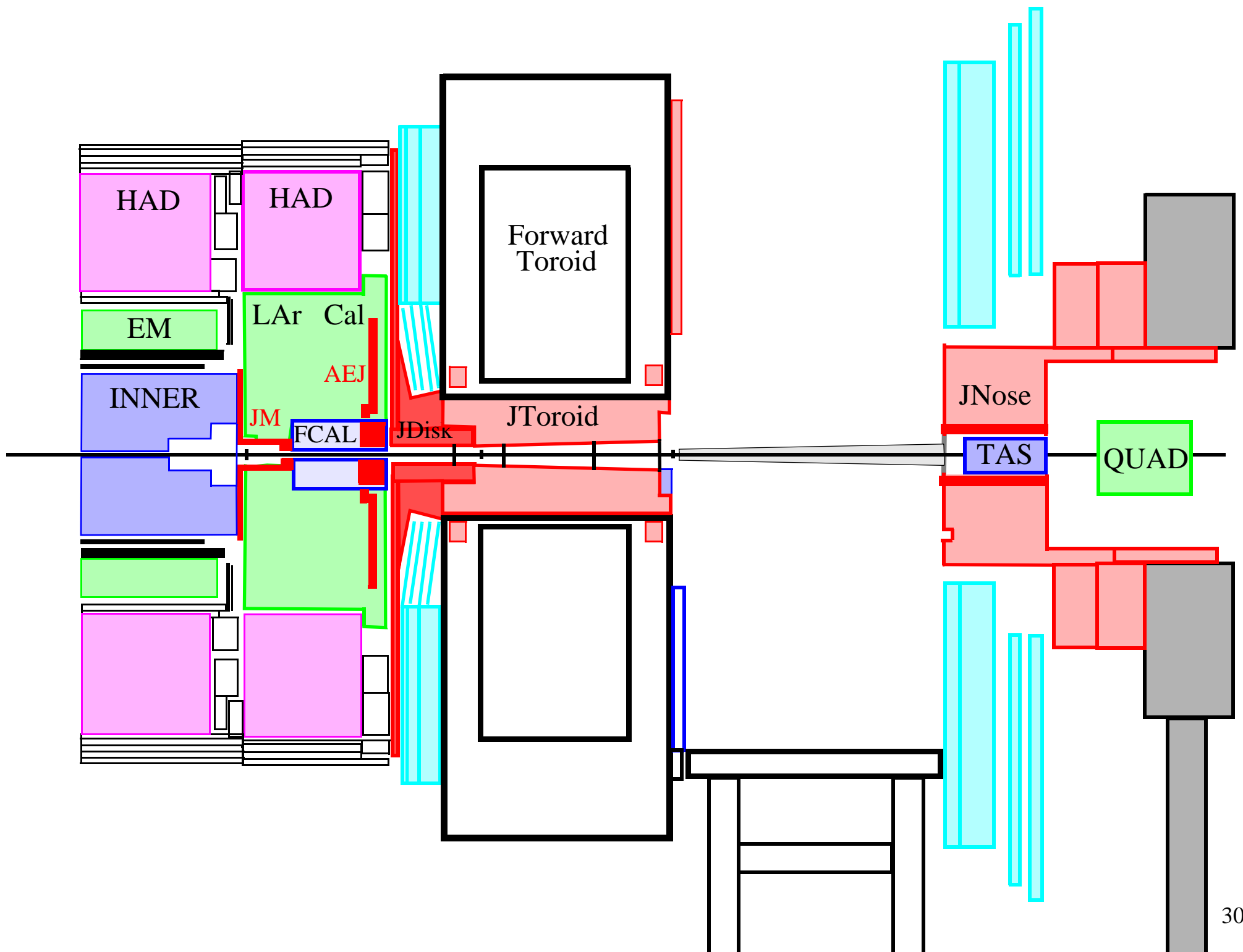

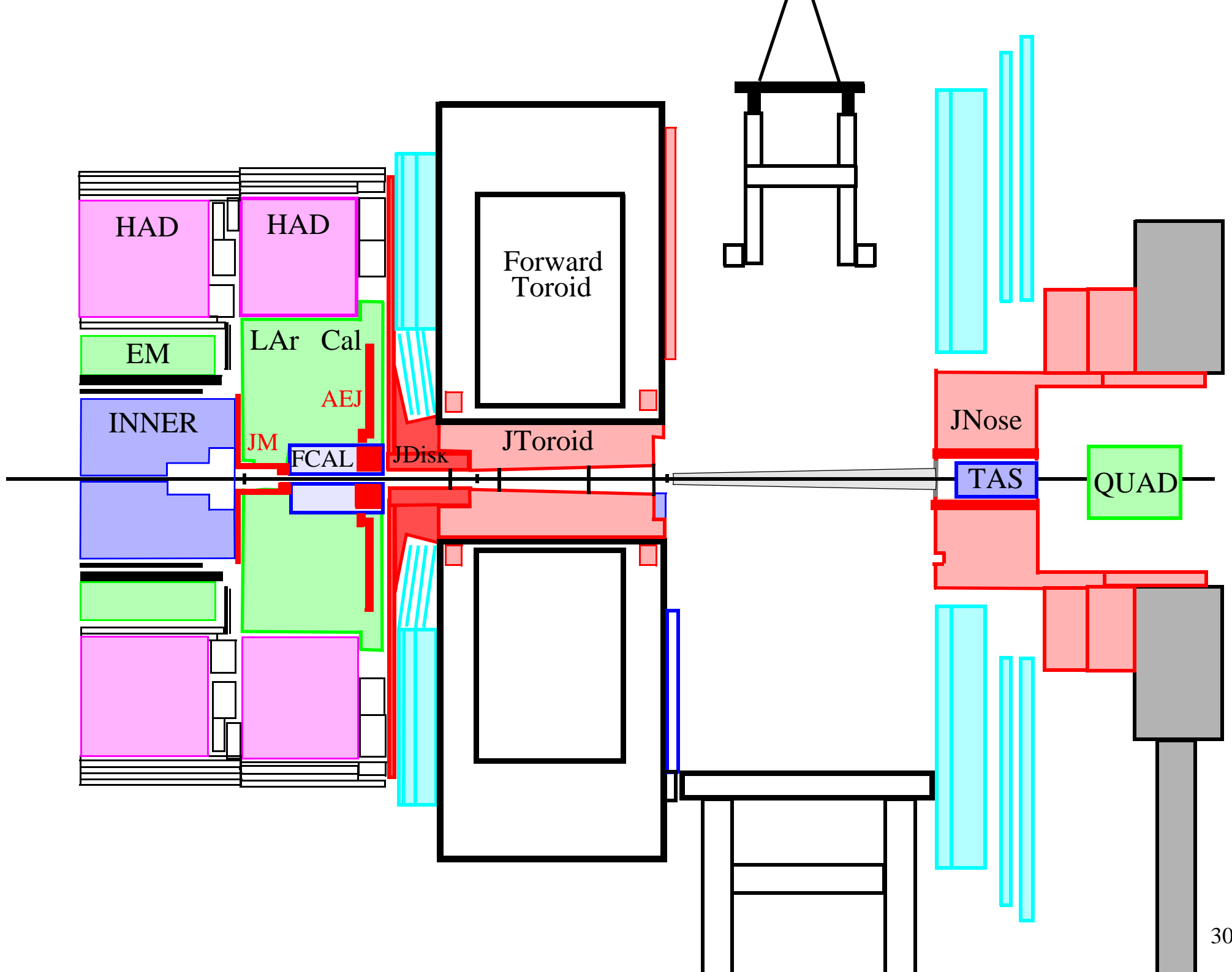

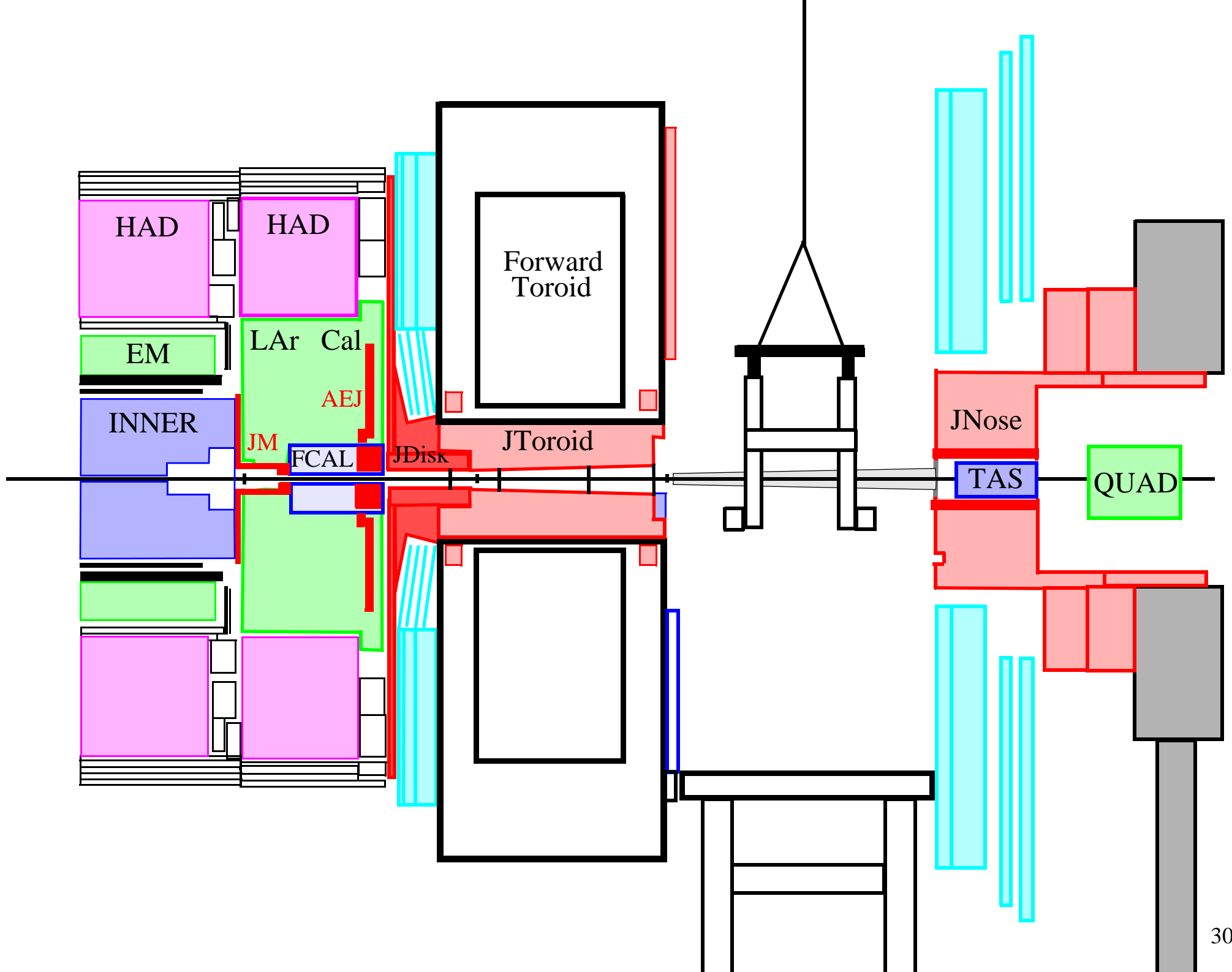

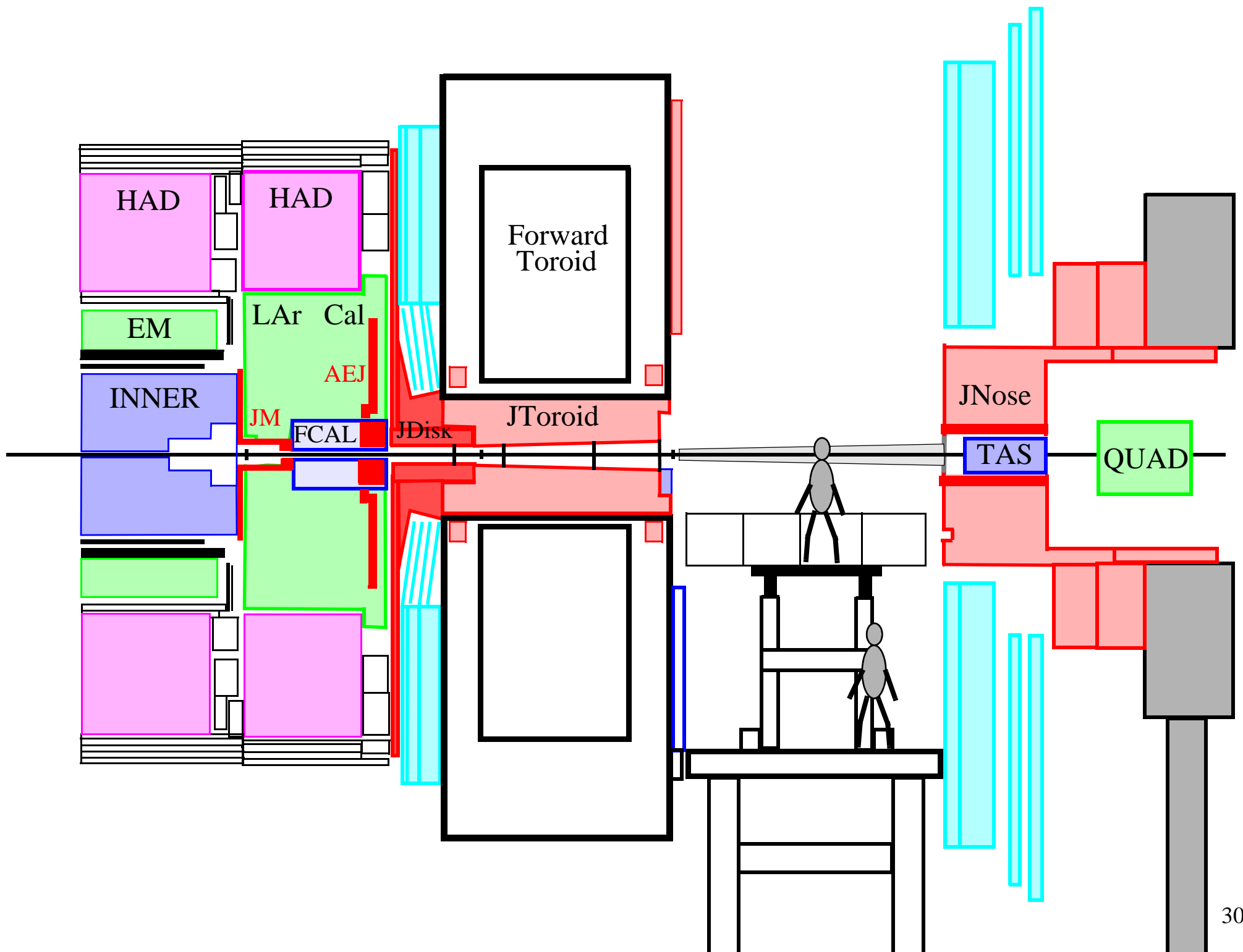

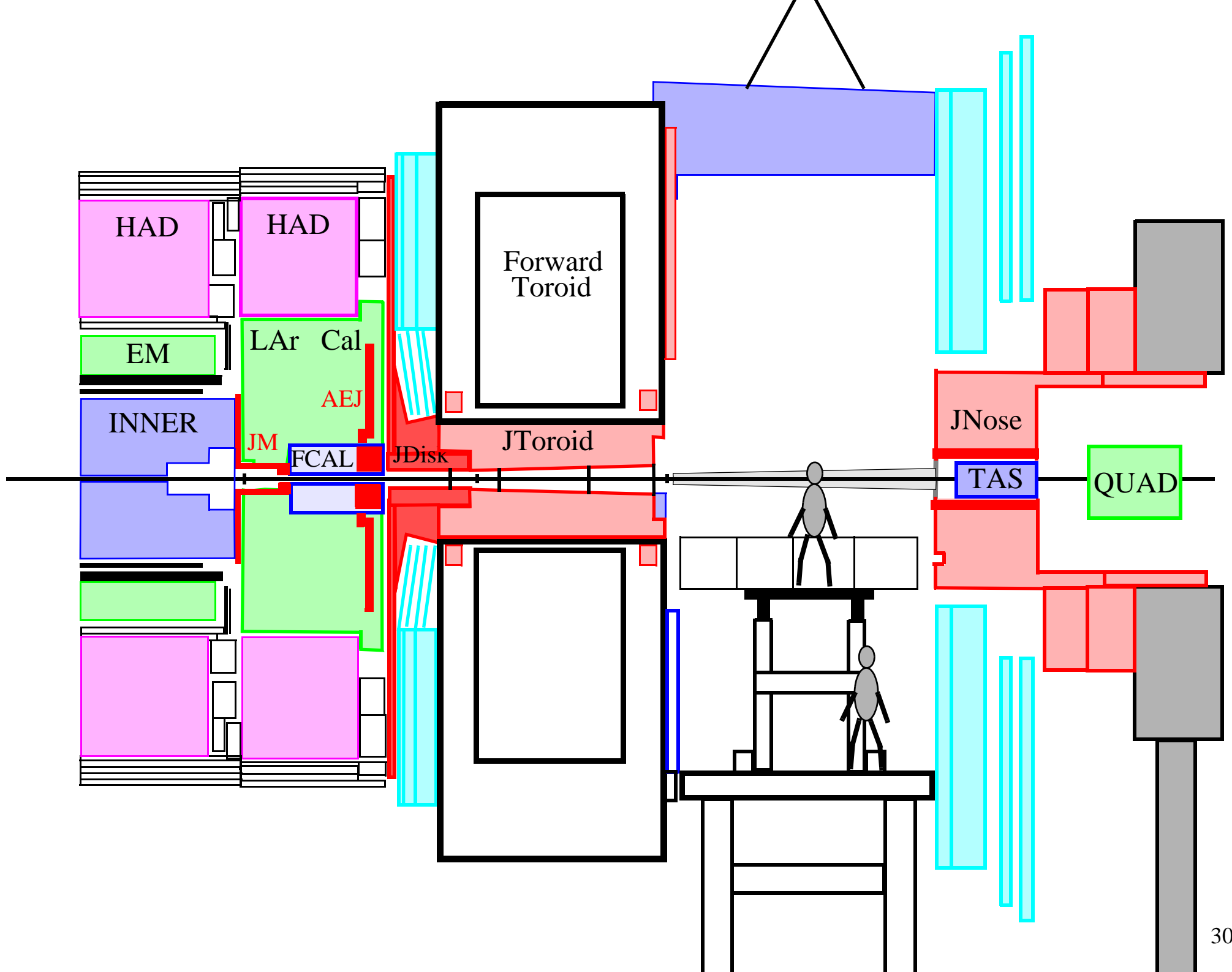

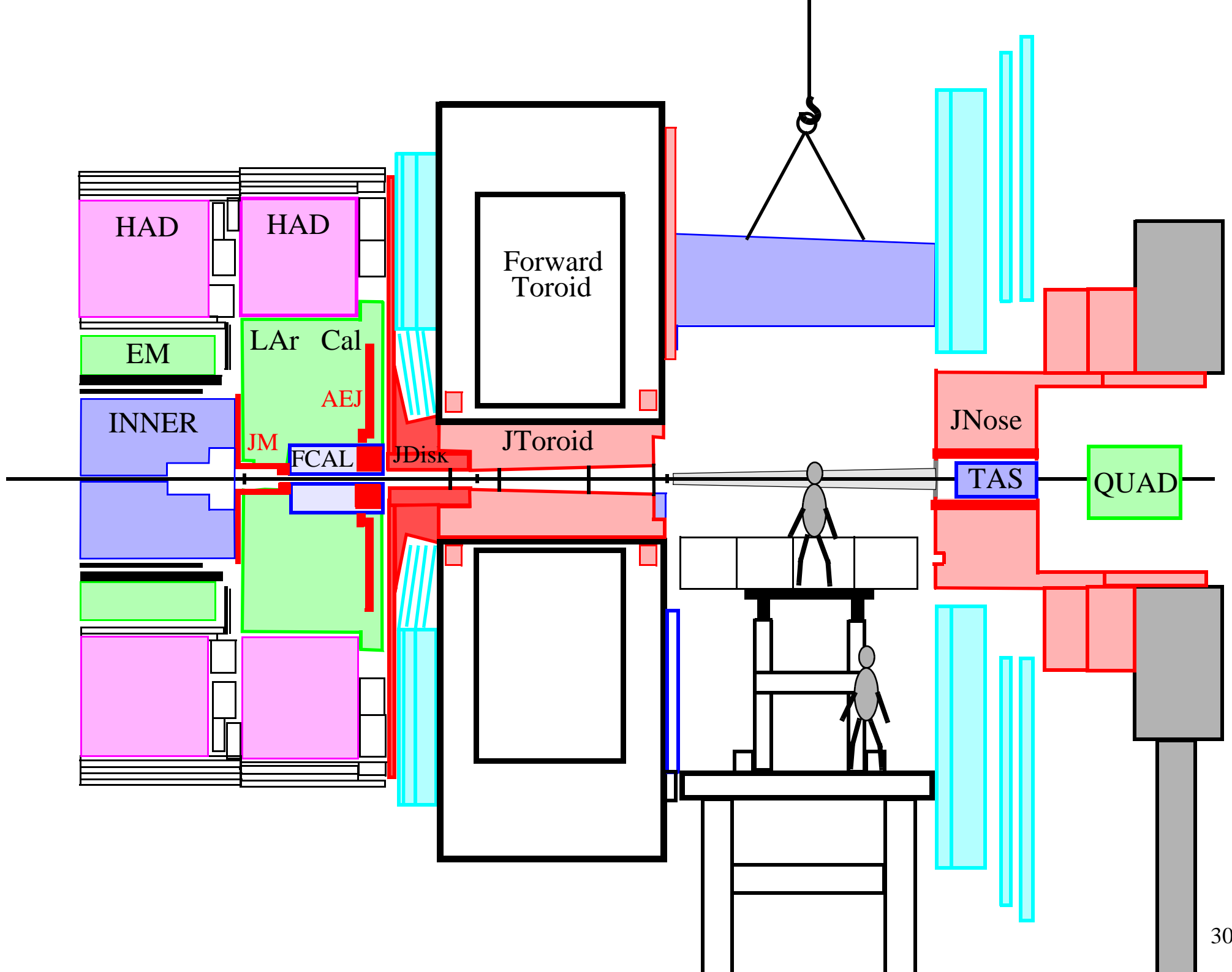

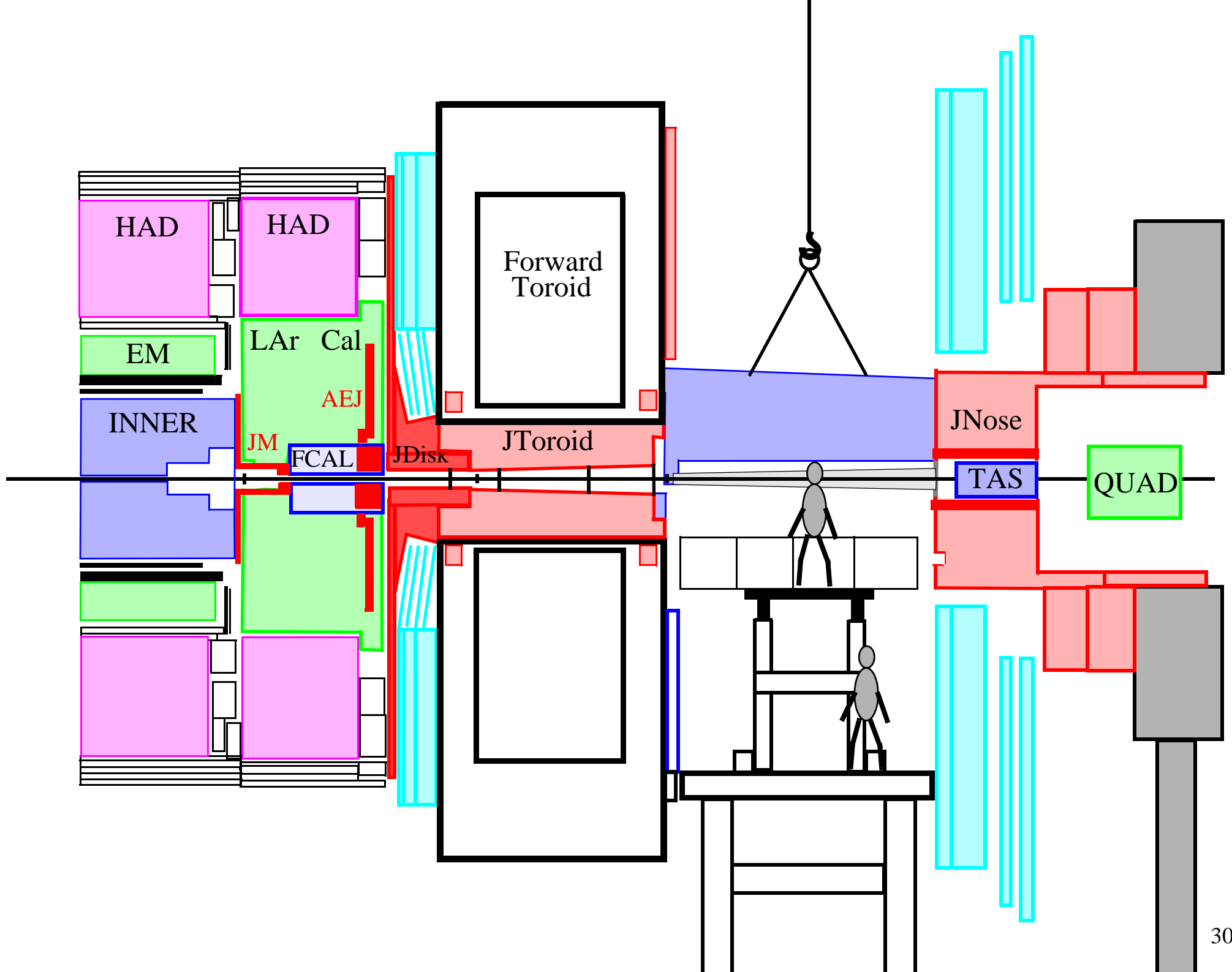

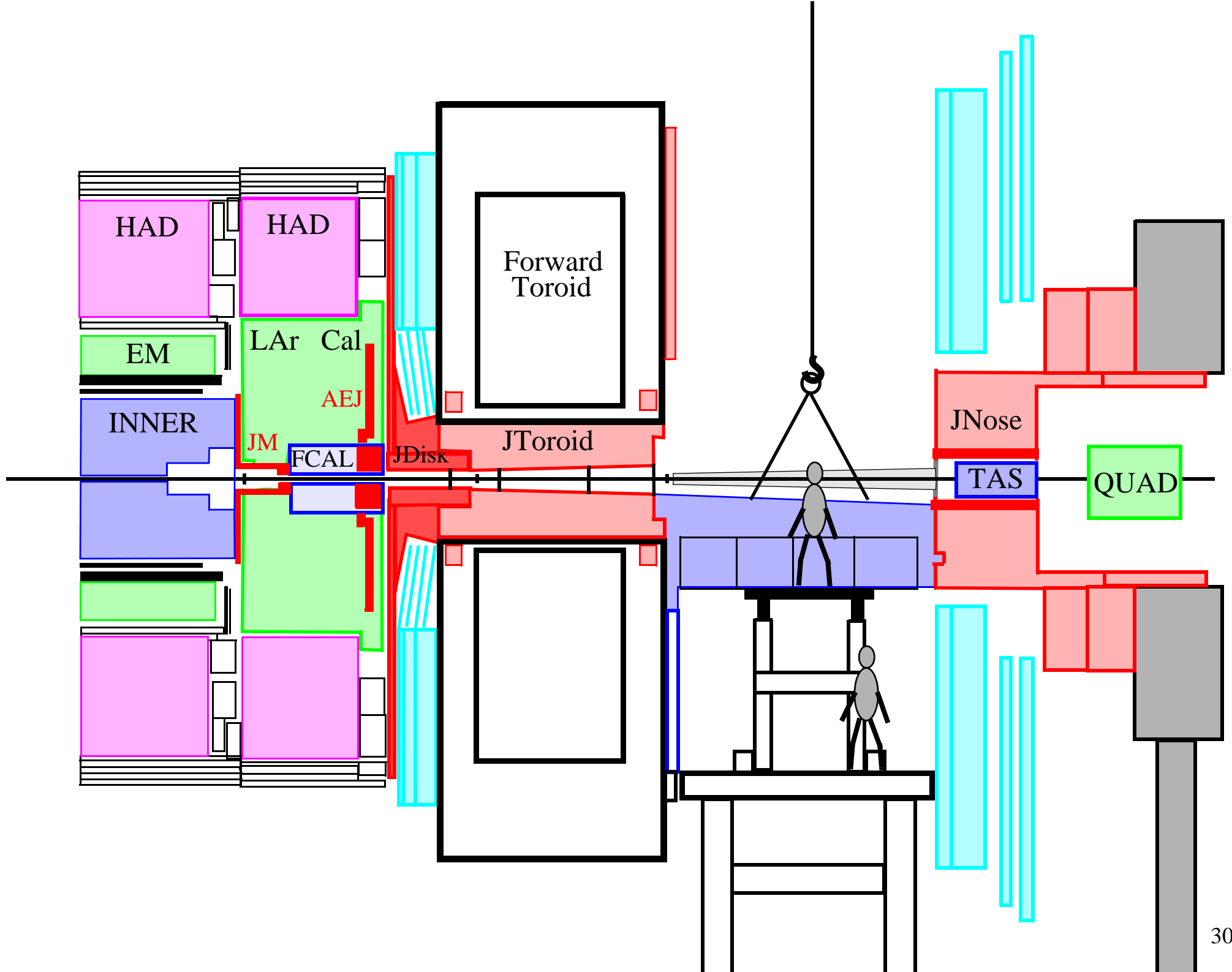

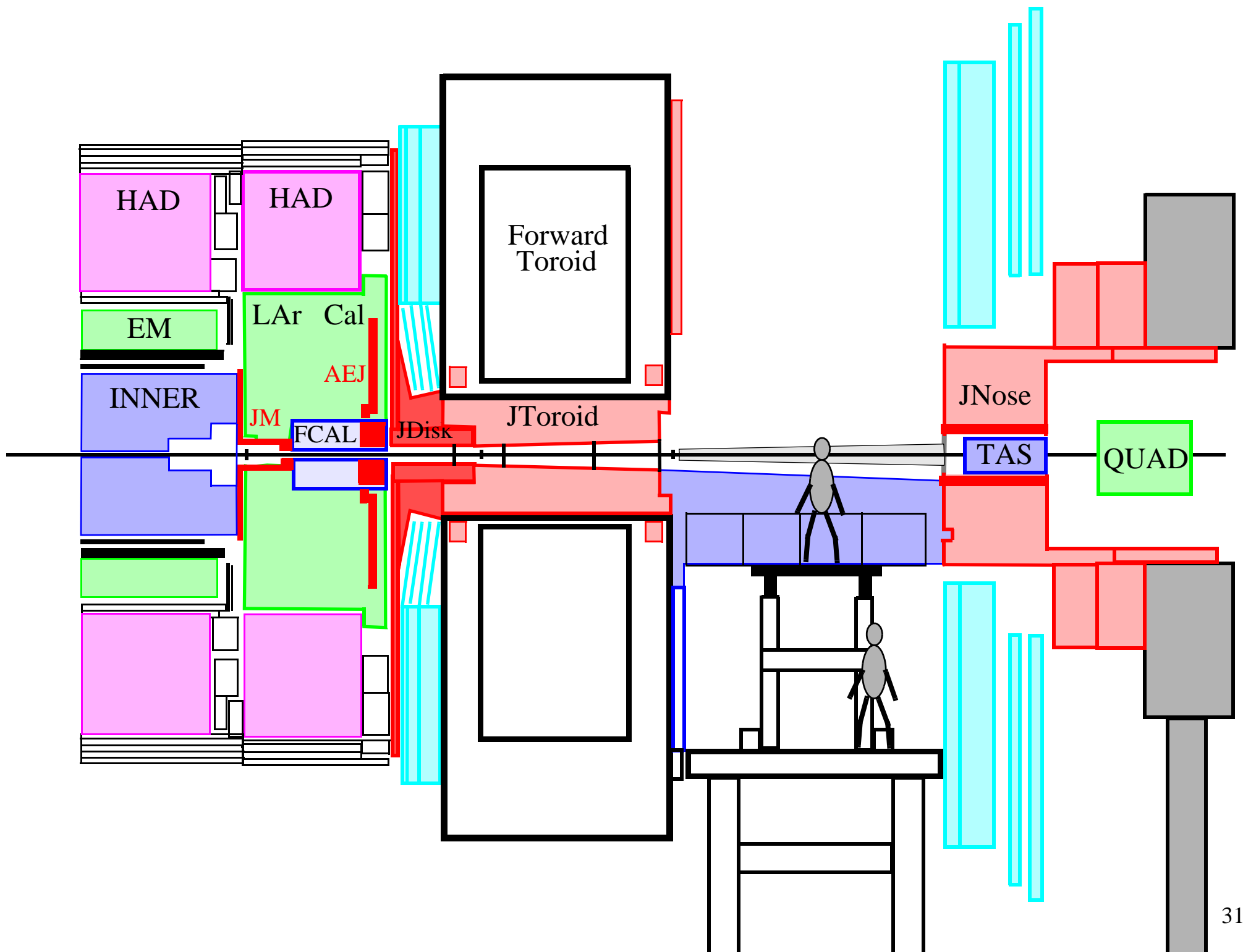

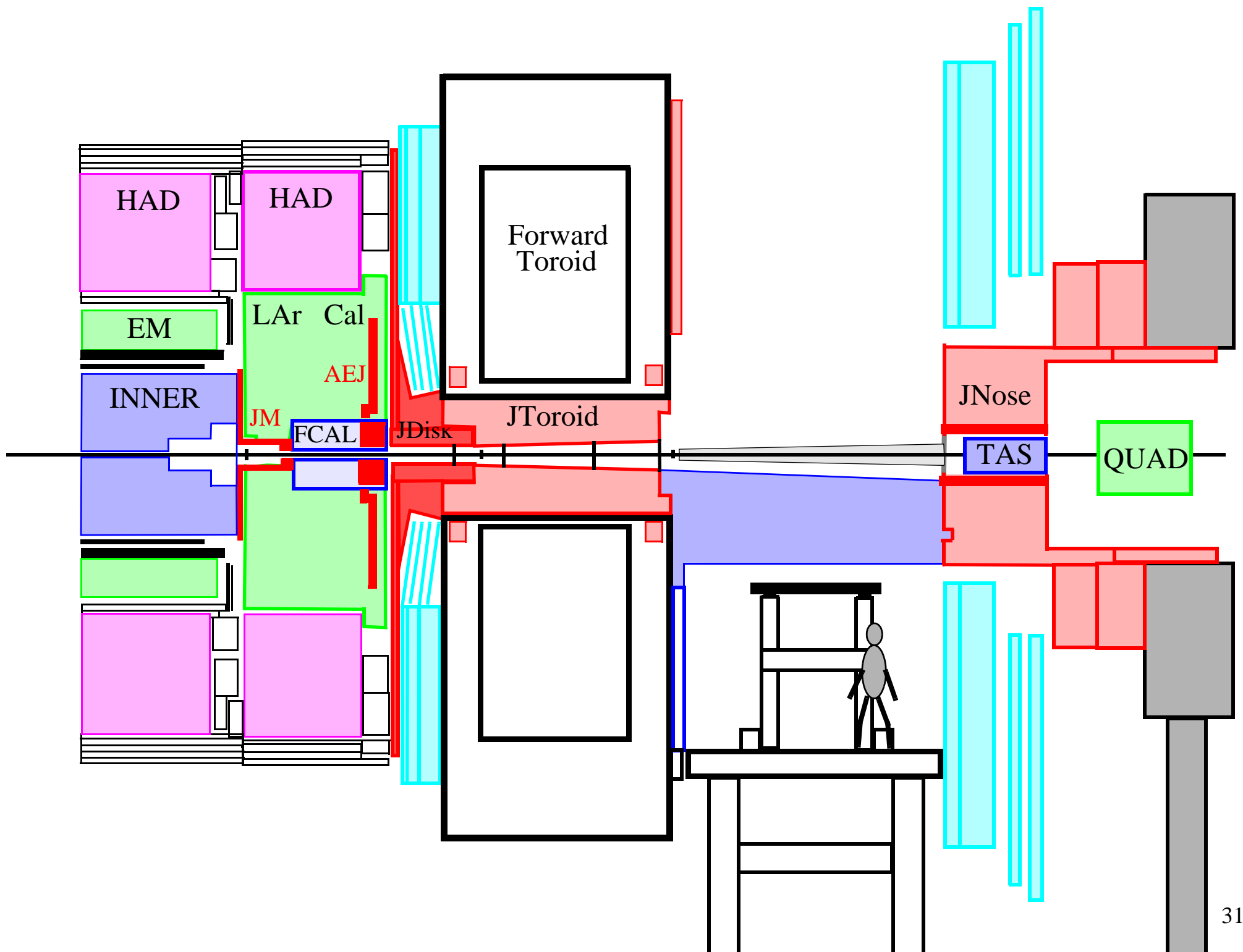

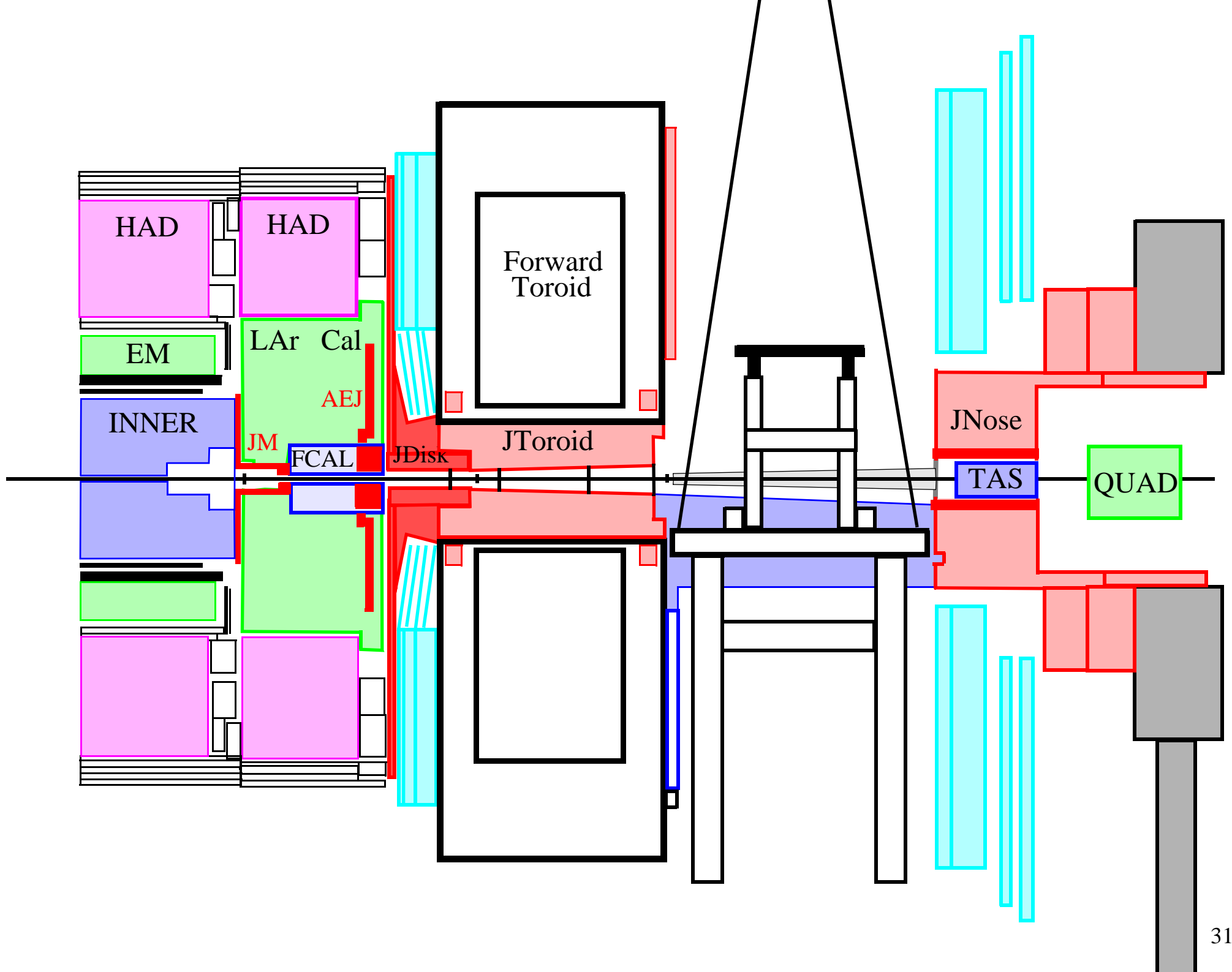

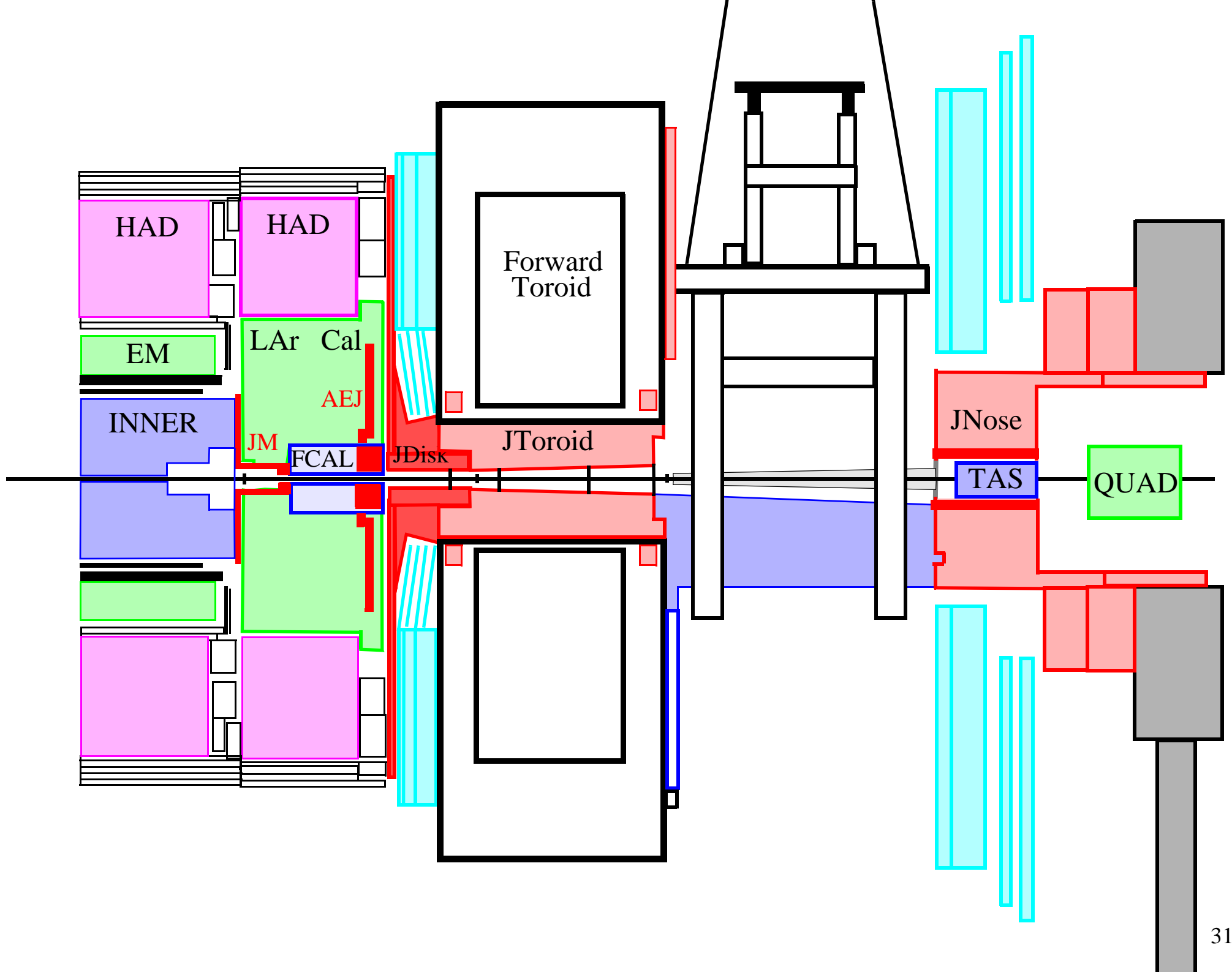

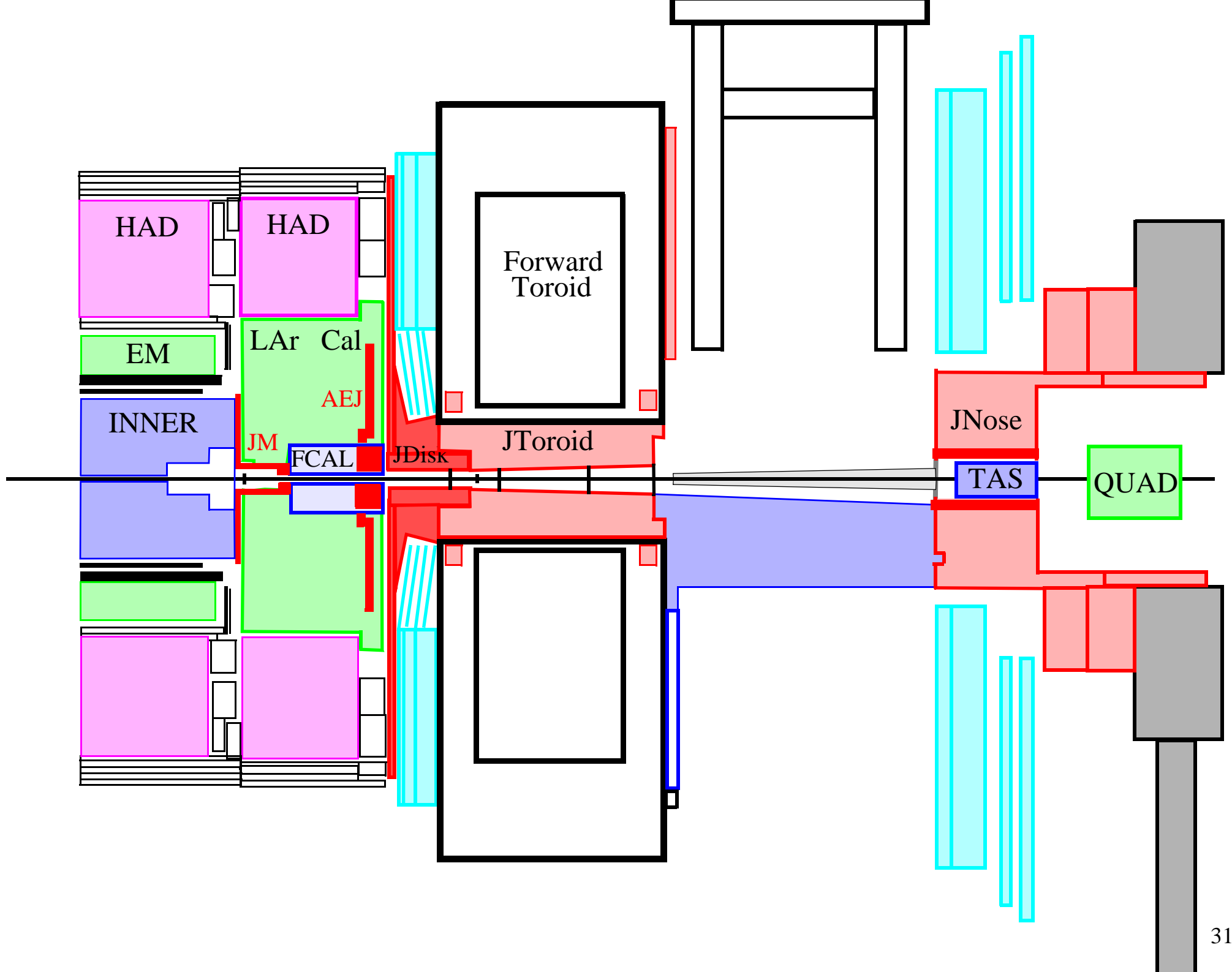

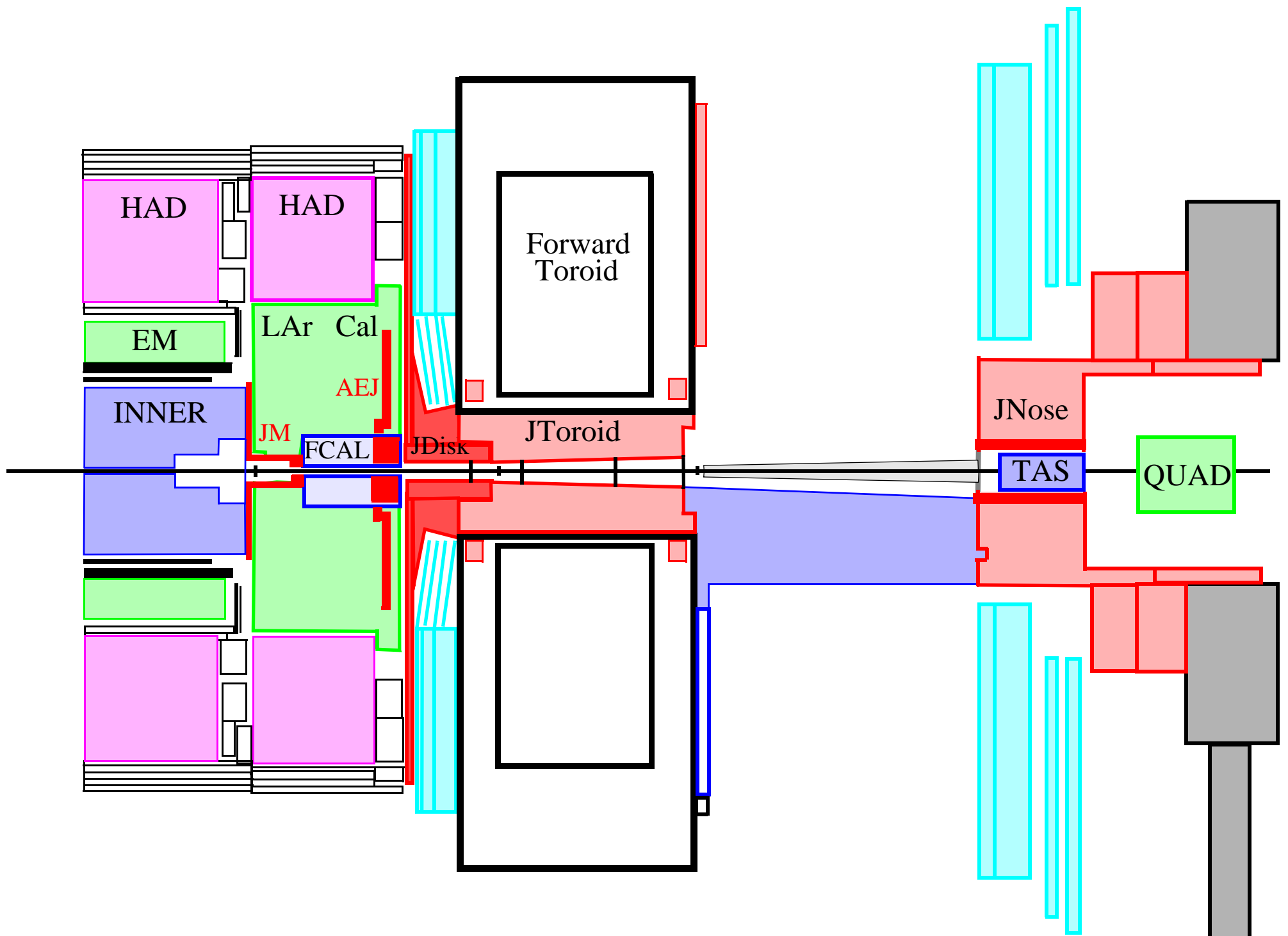

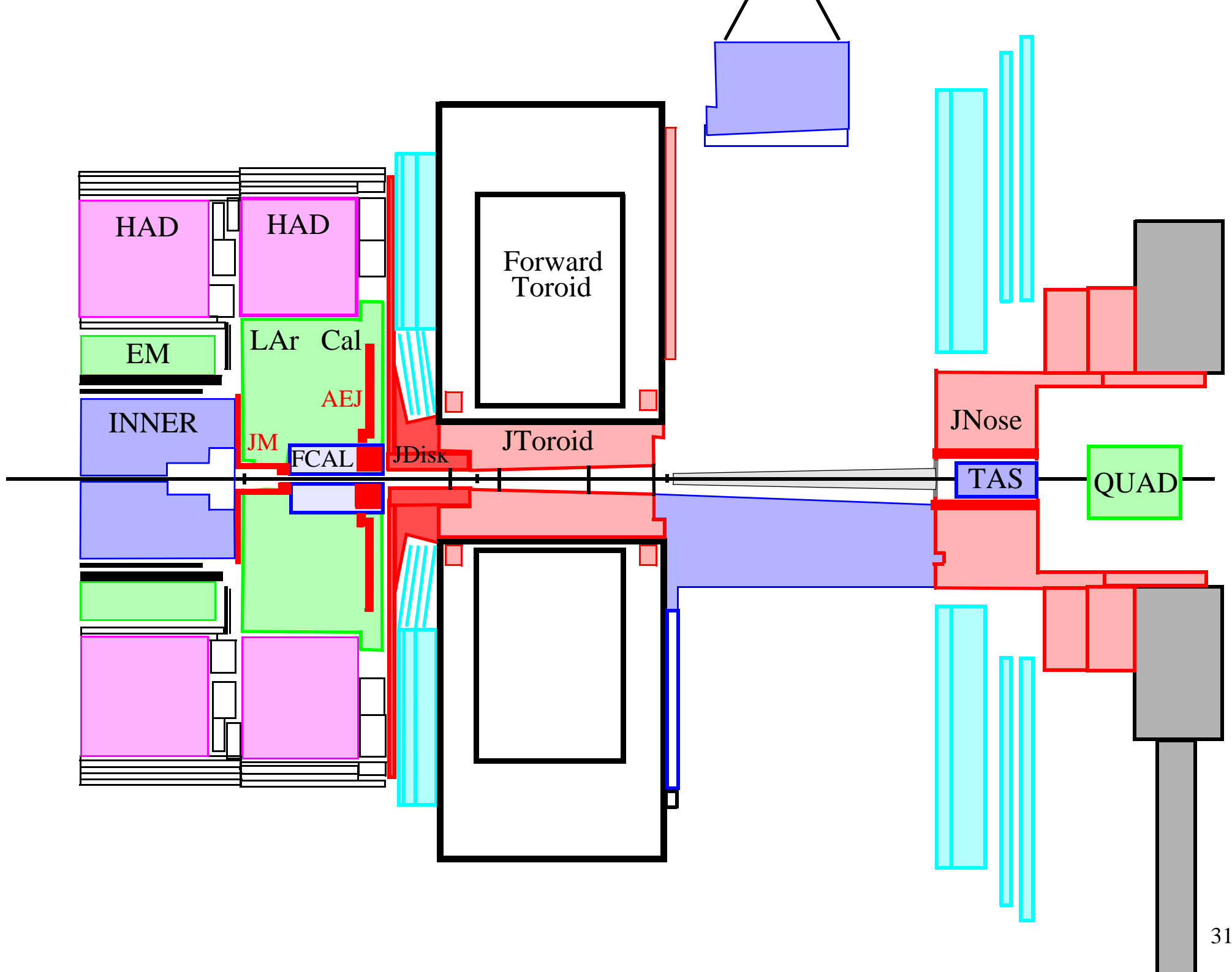

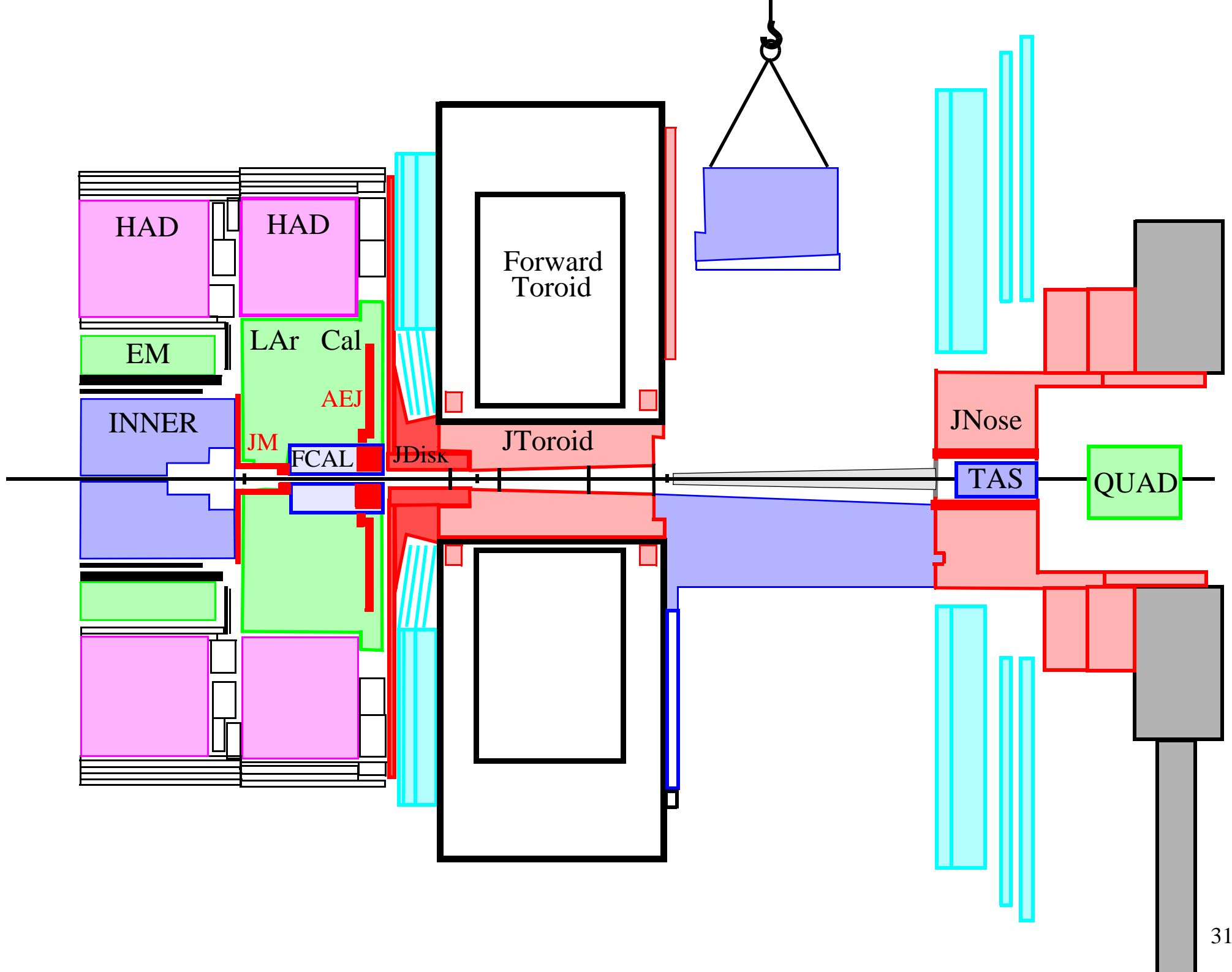

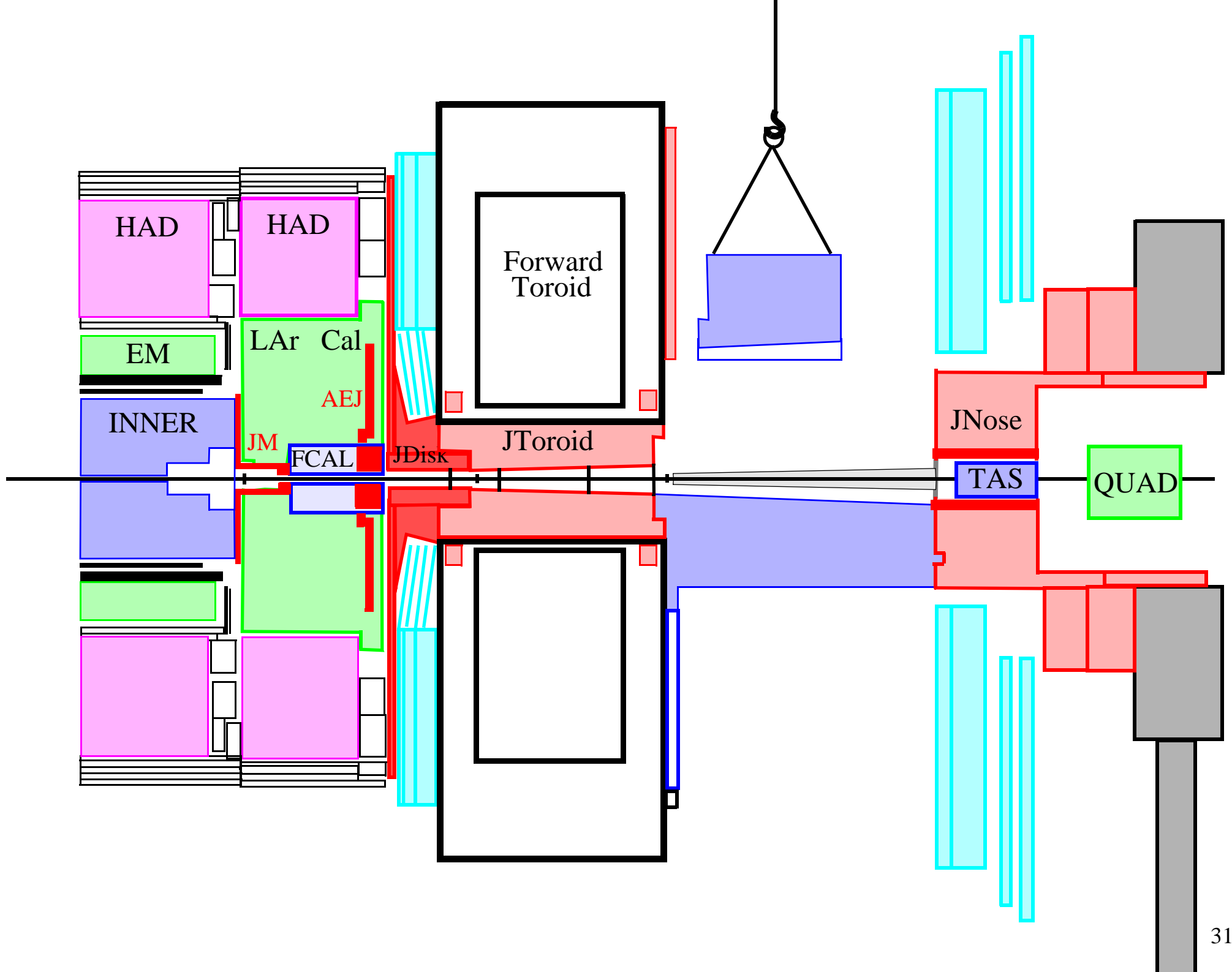

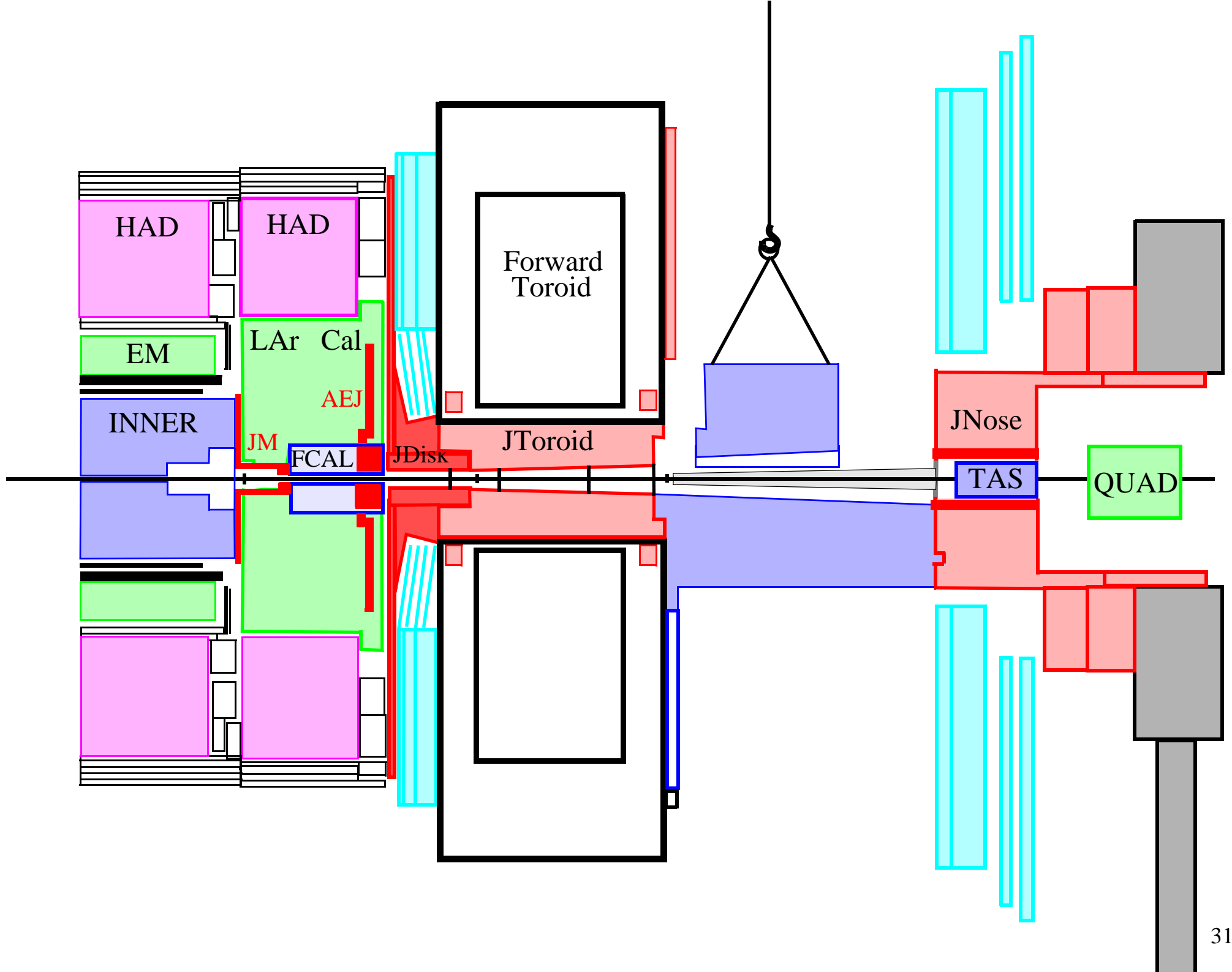

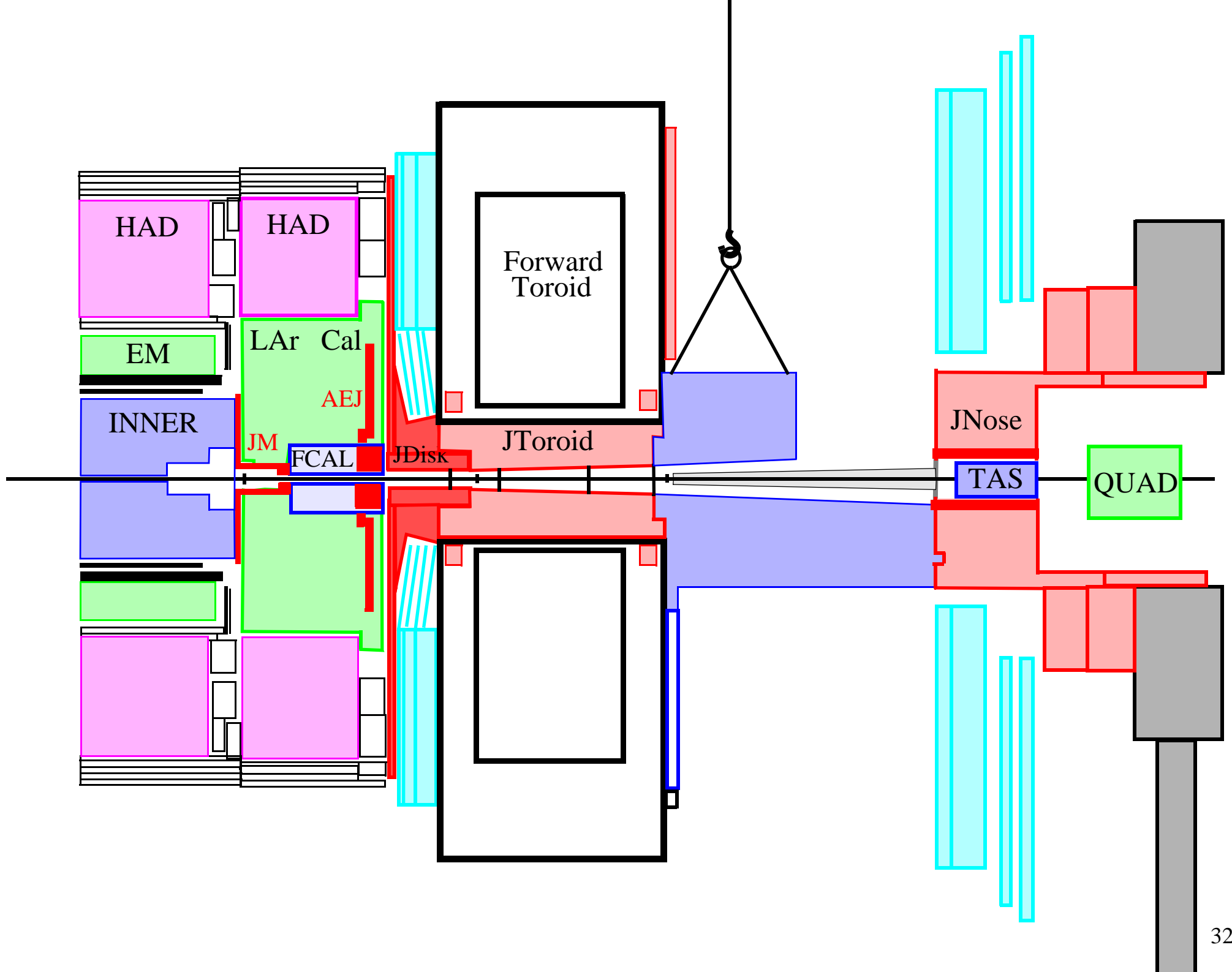

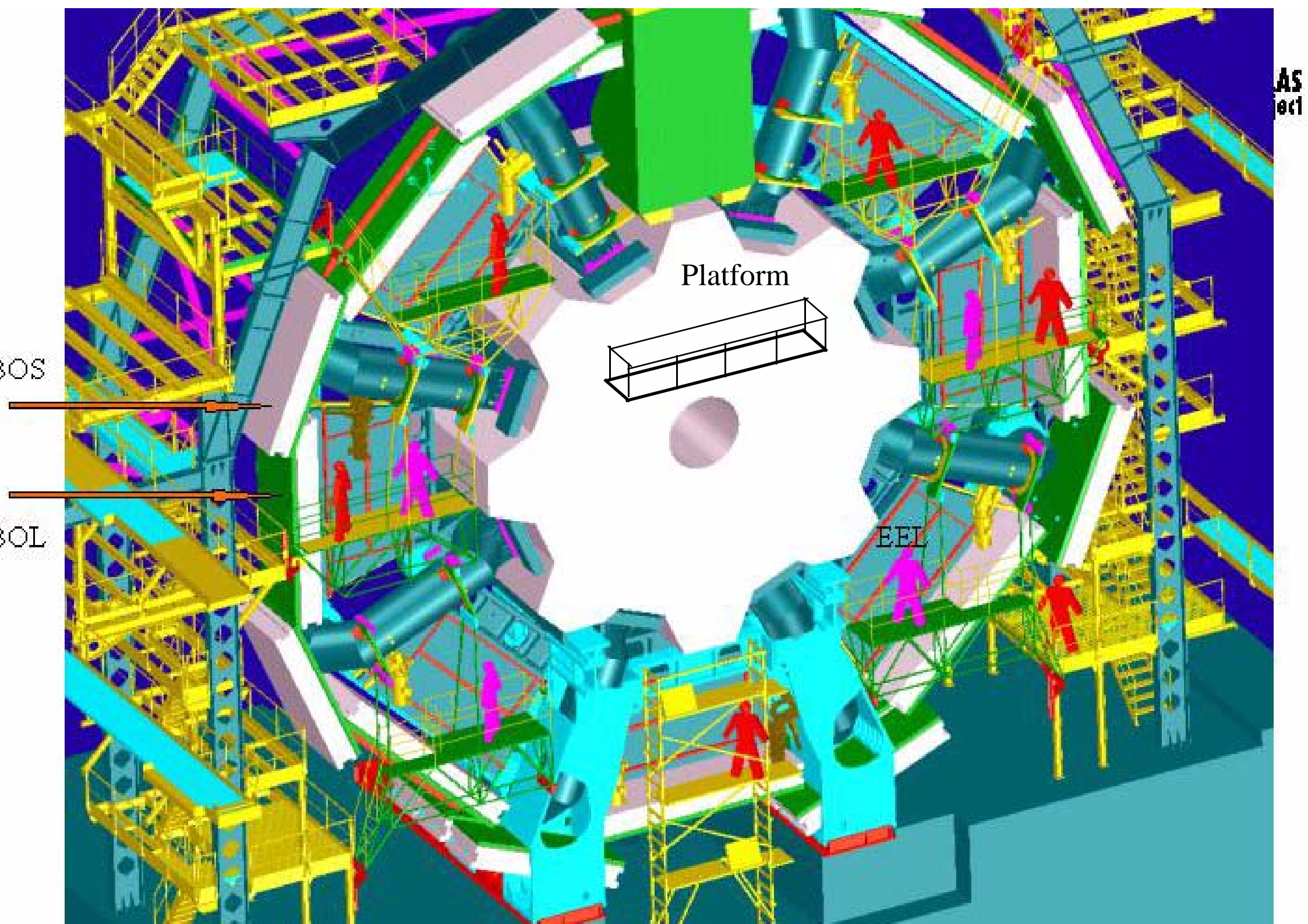

Platform

SOS

SOL

EEL

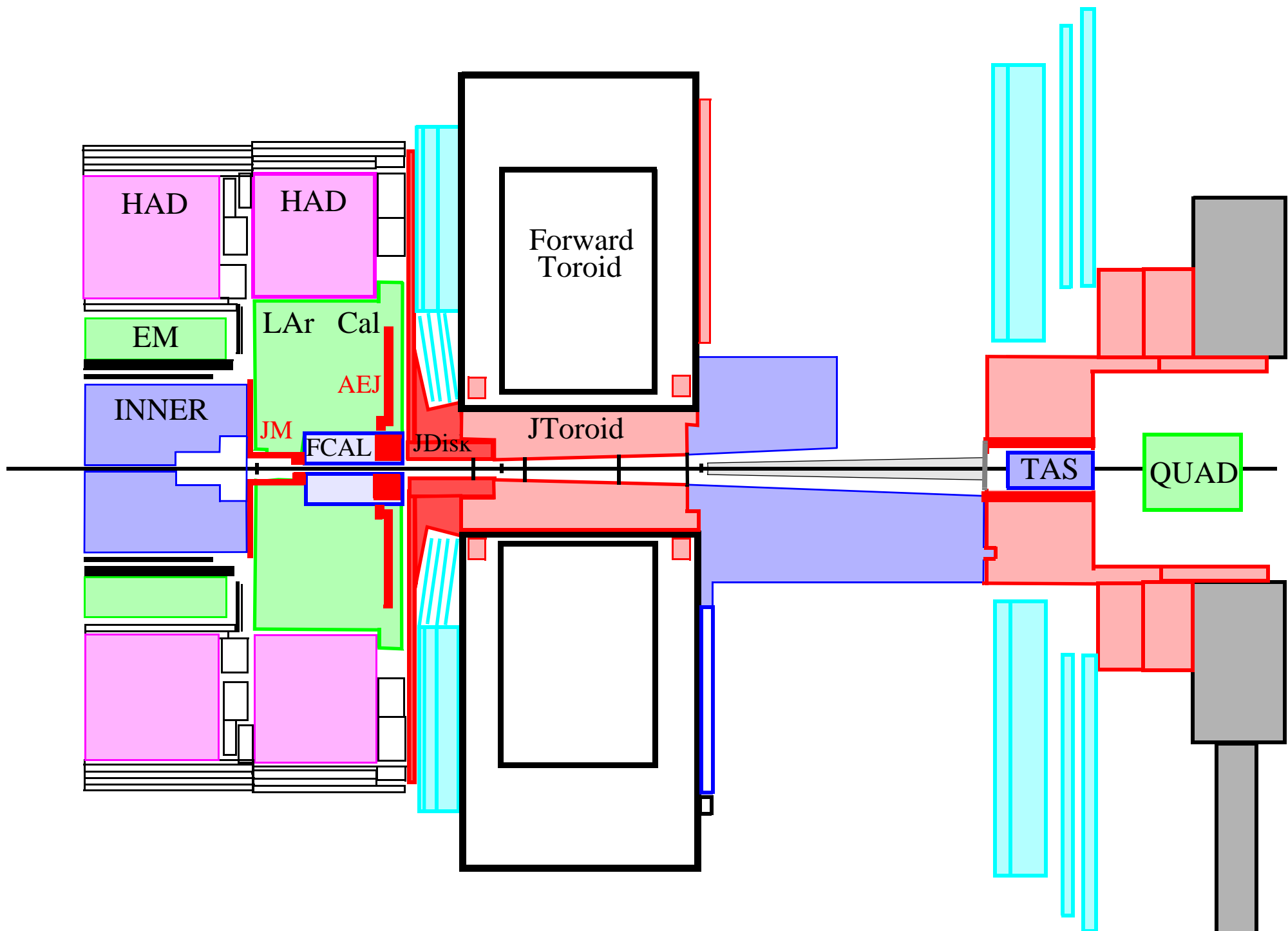

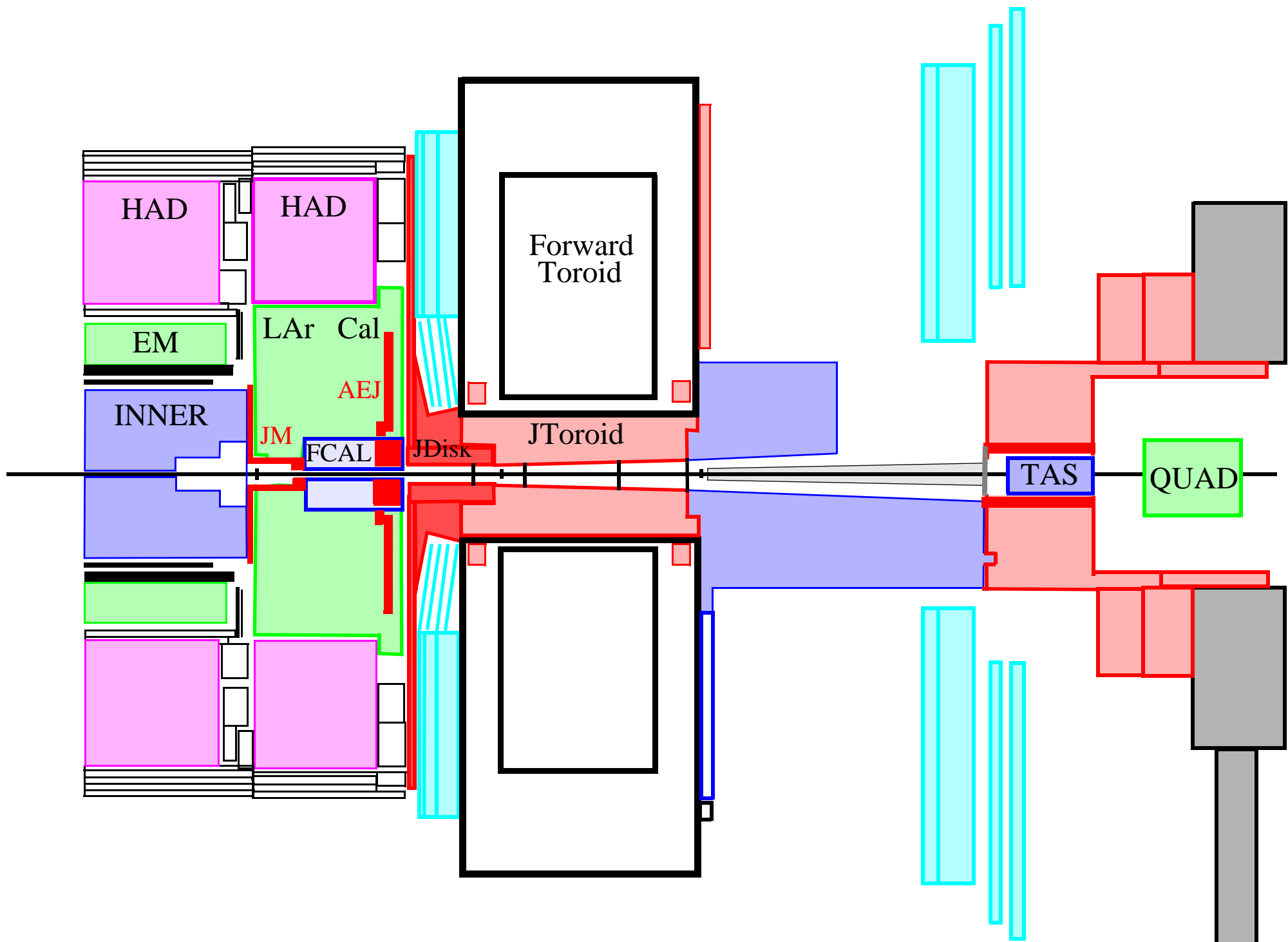

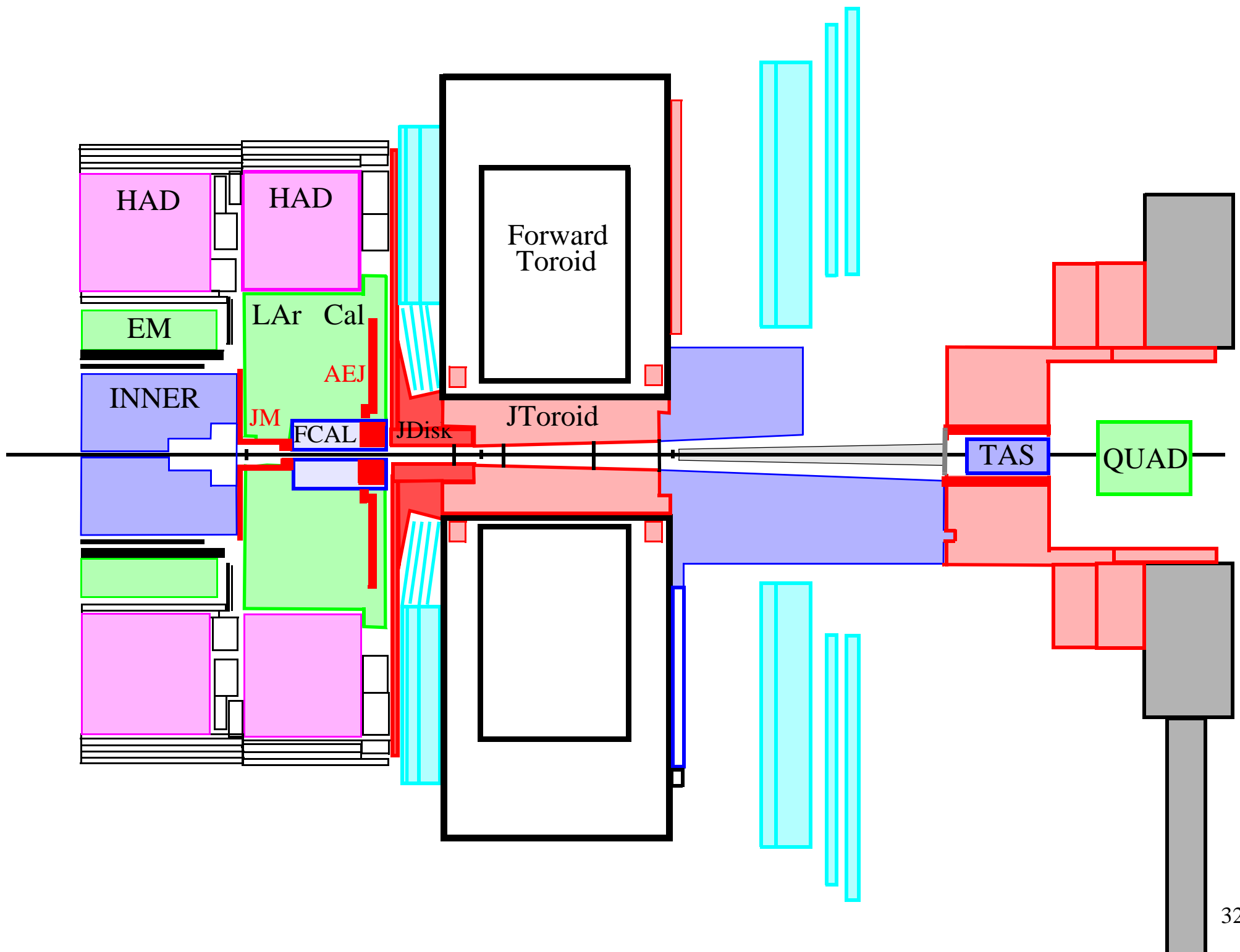

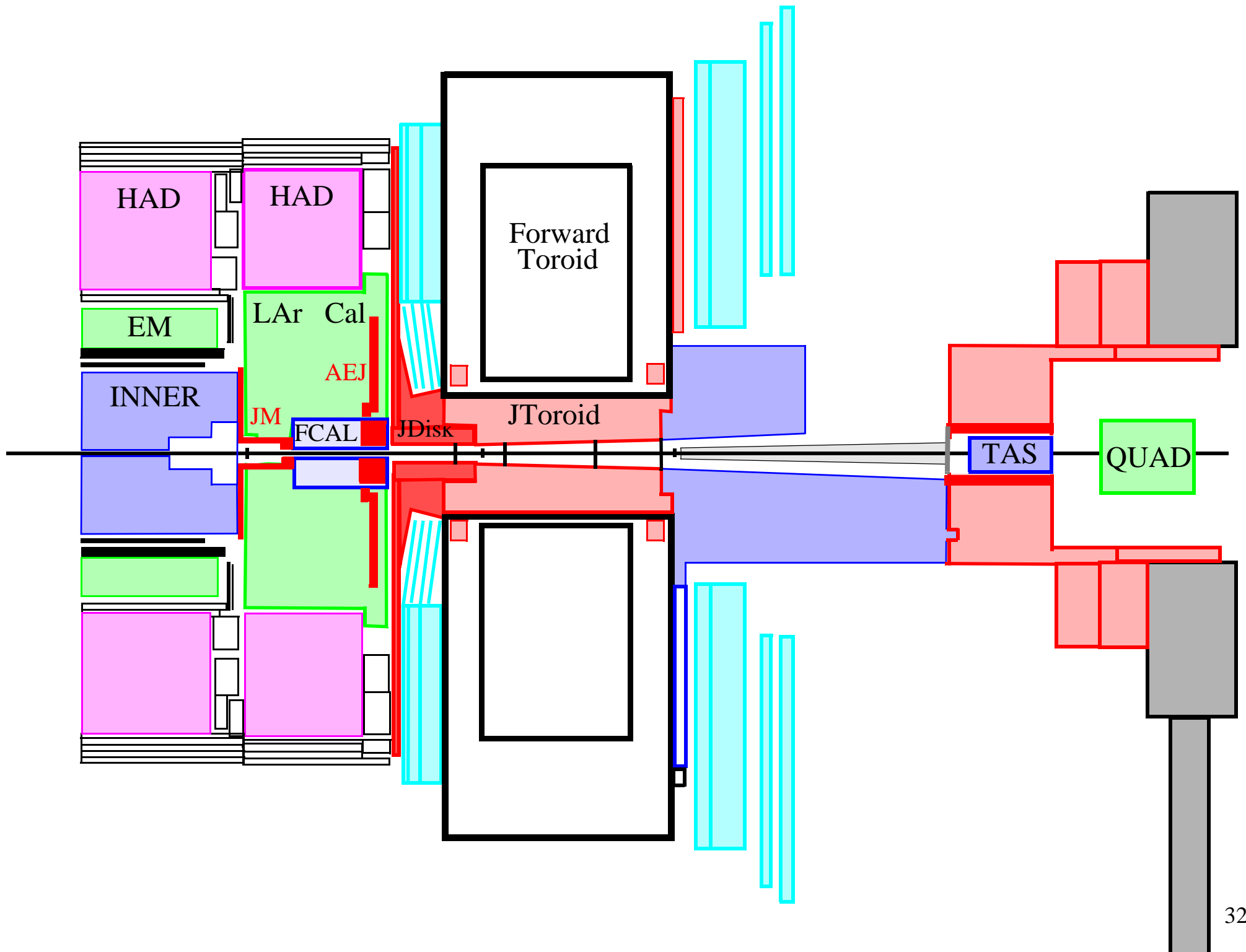

July 2007

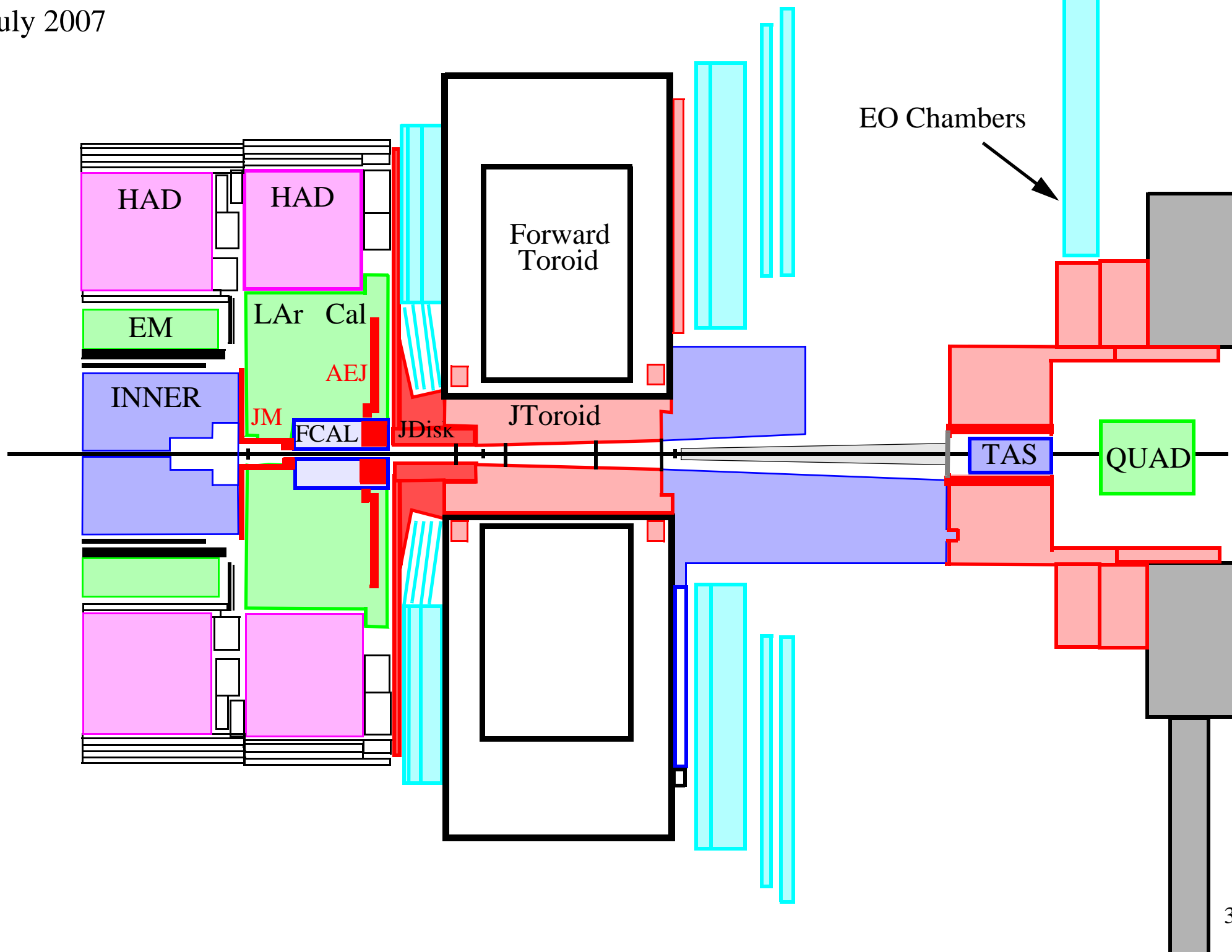

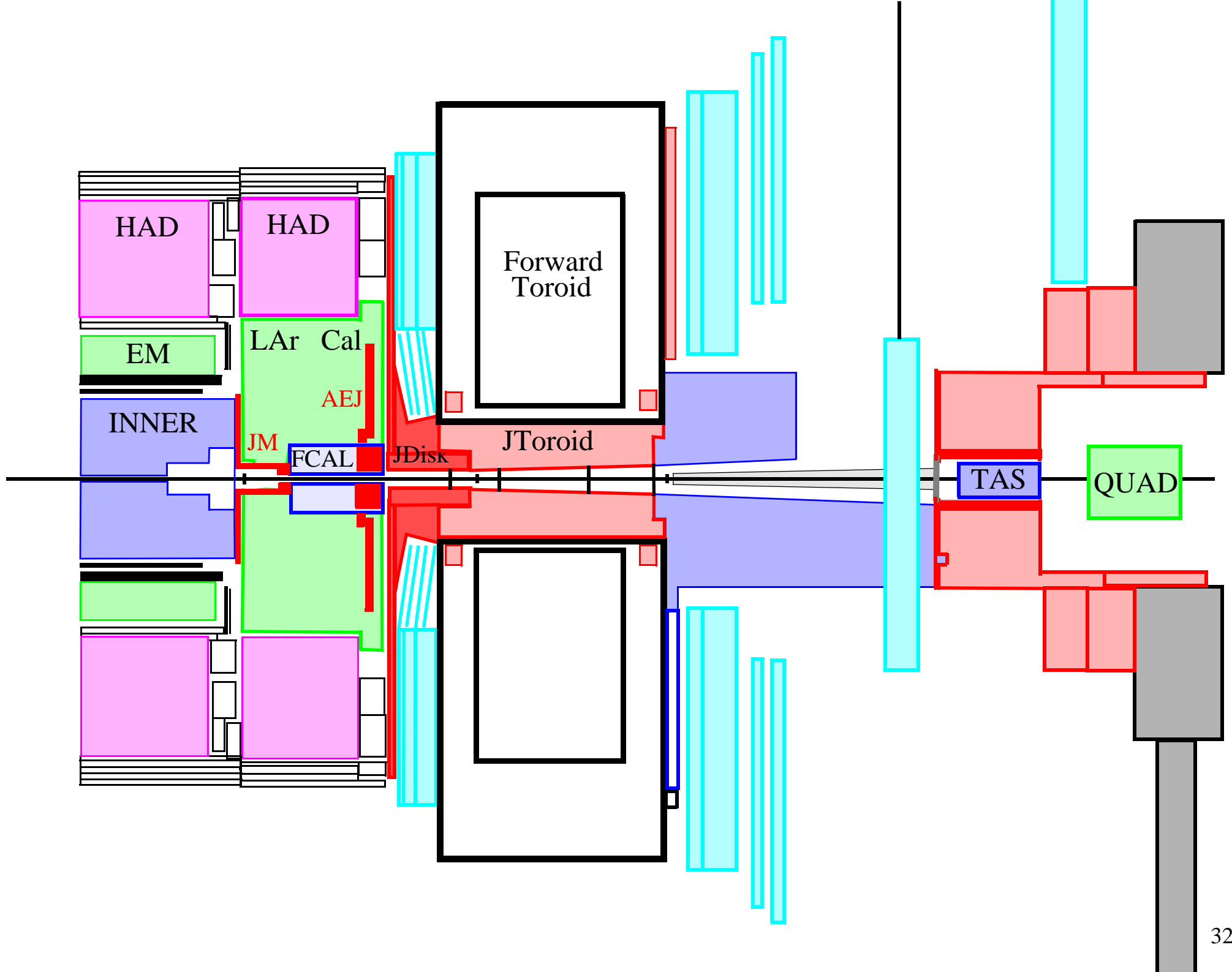

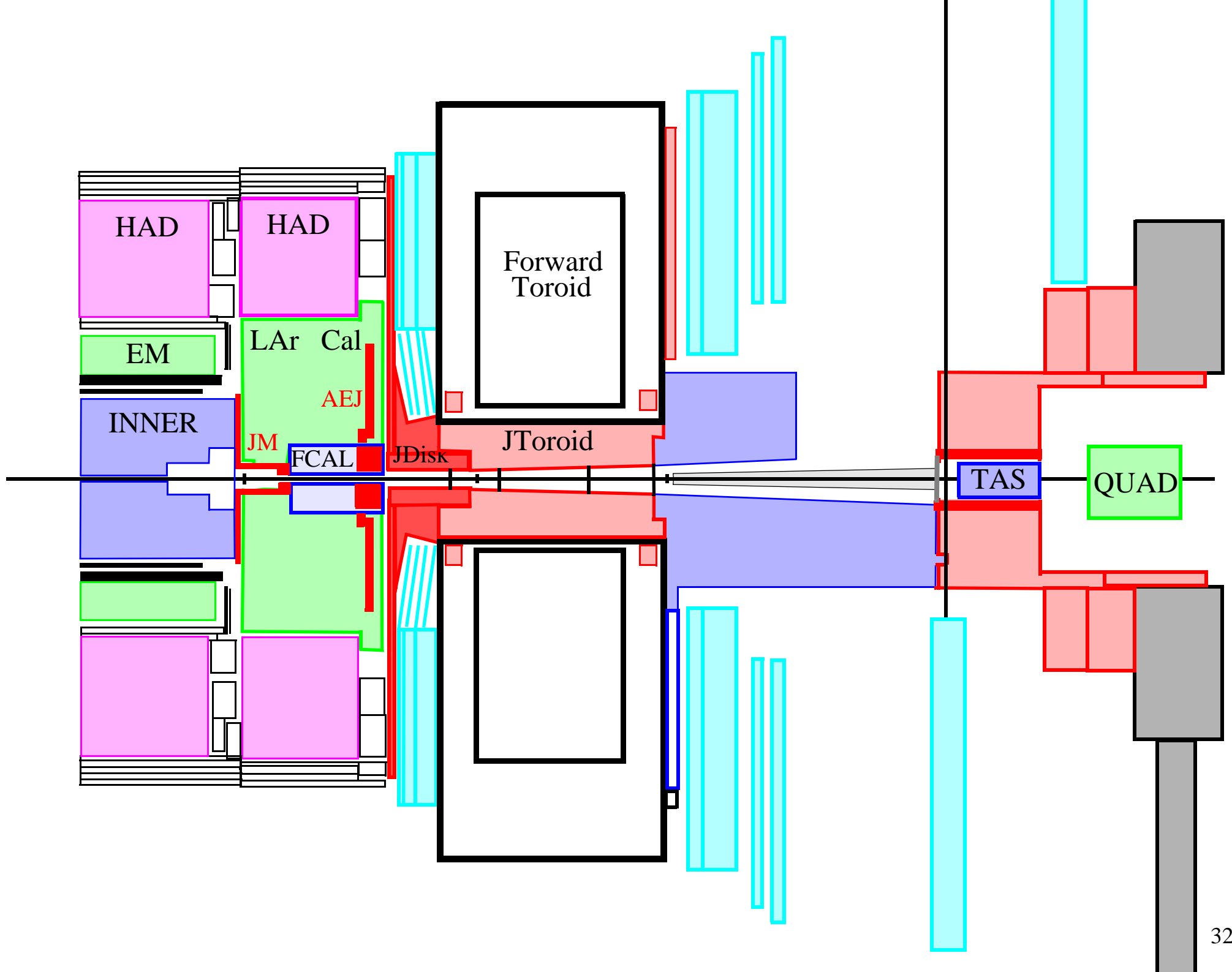

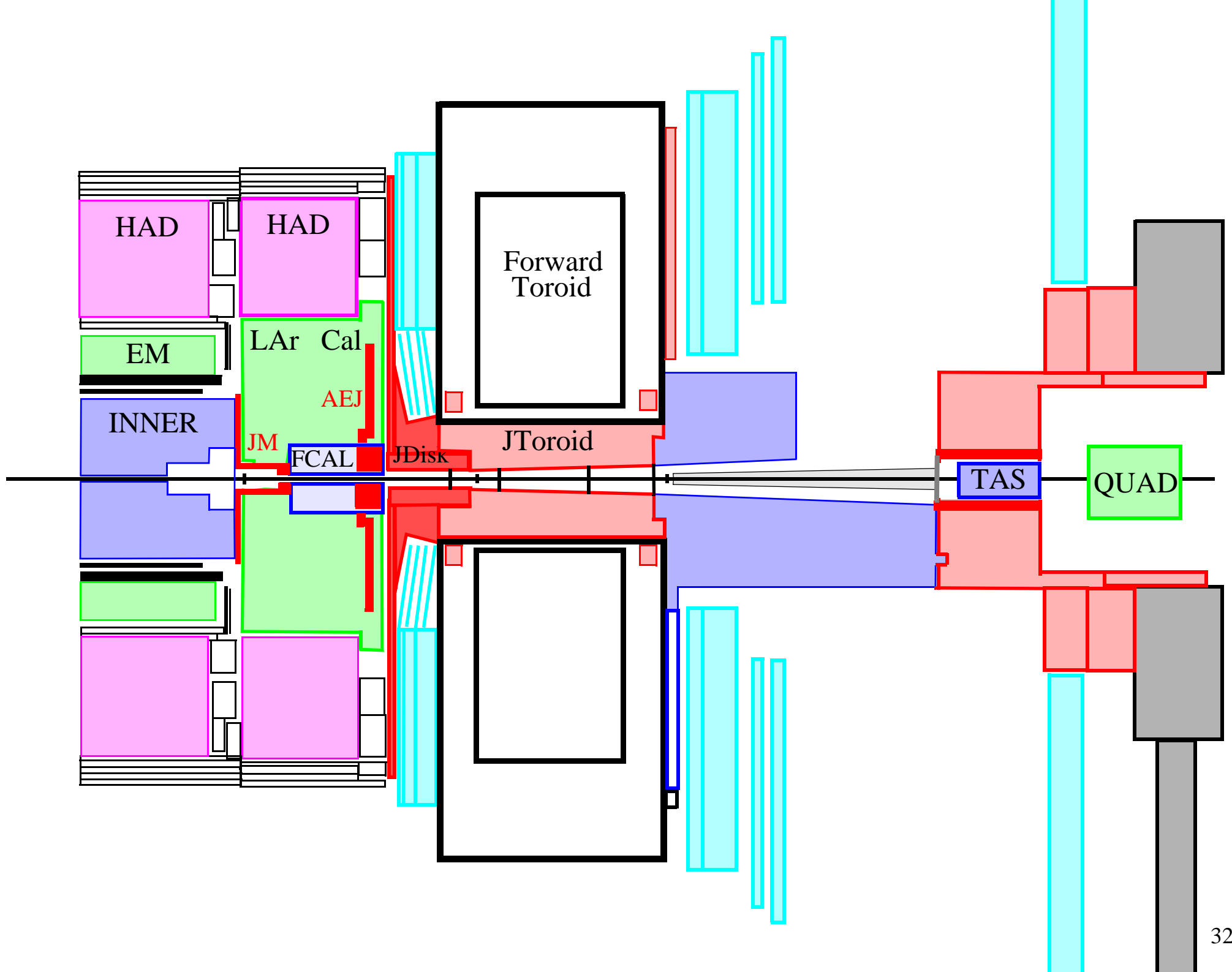

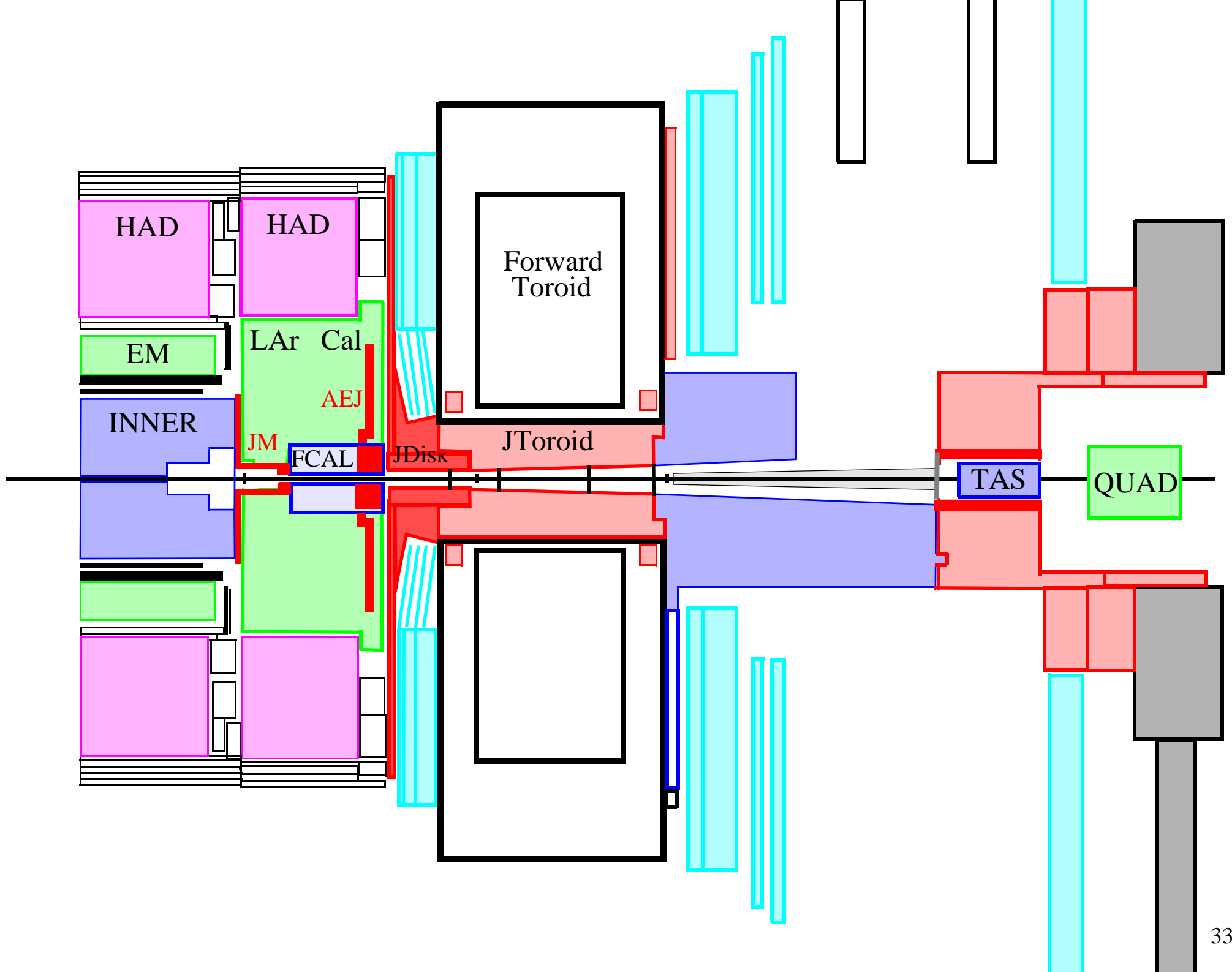

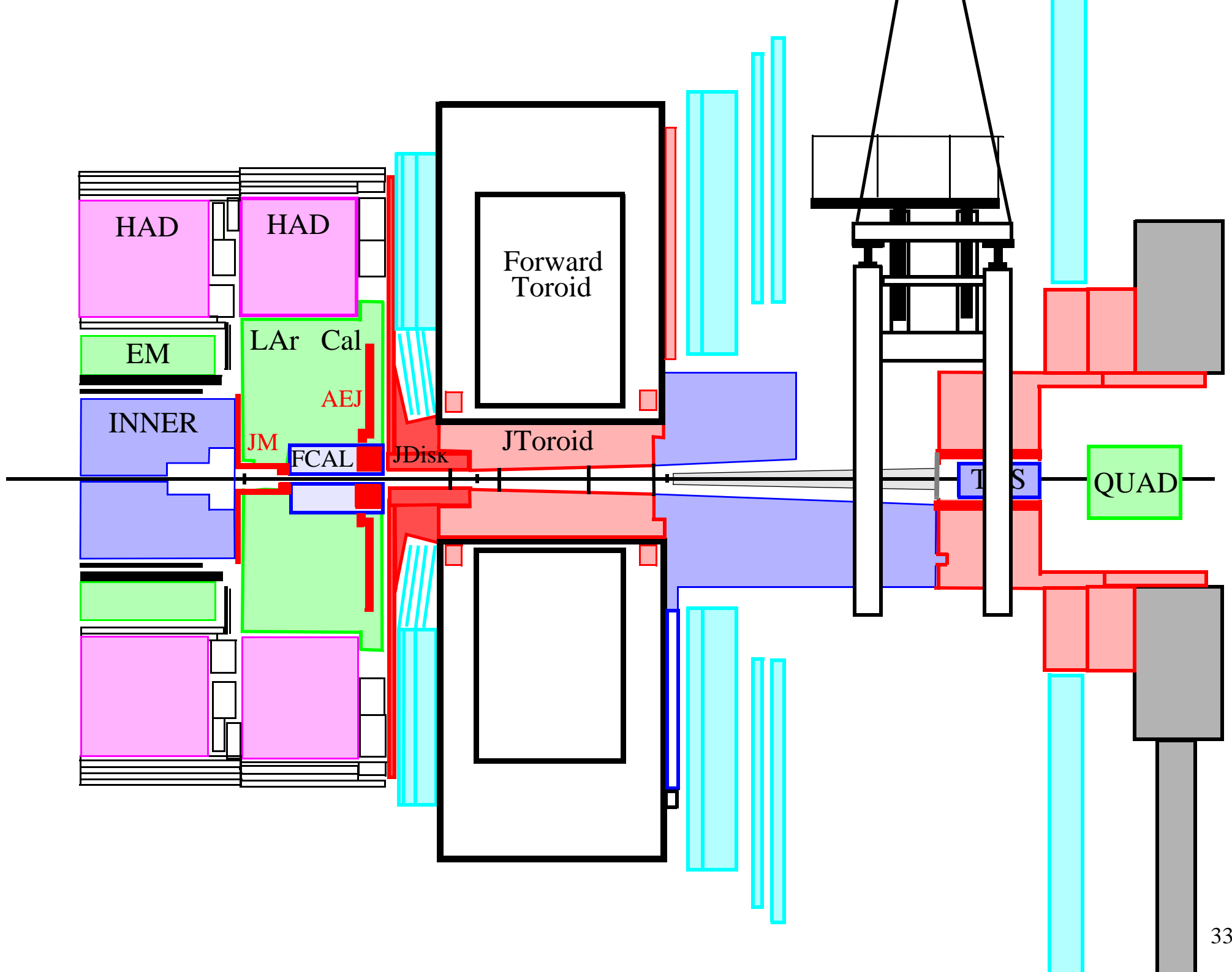

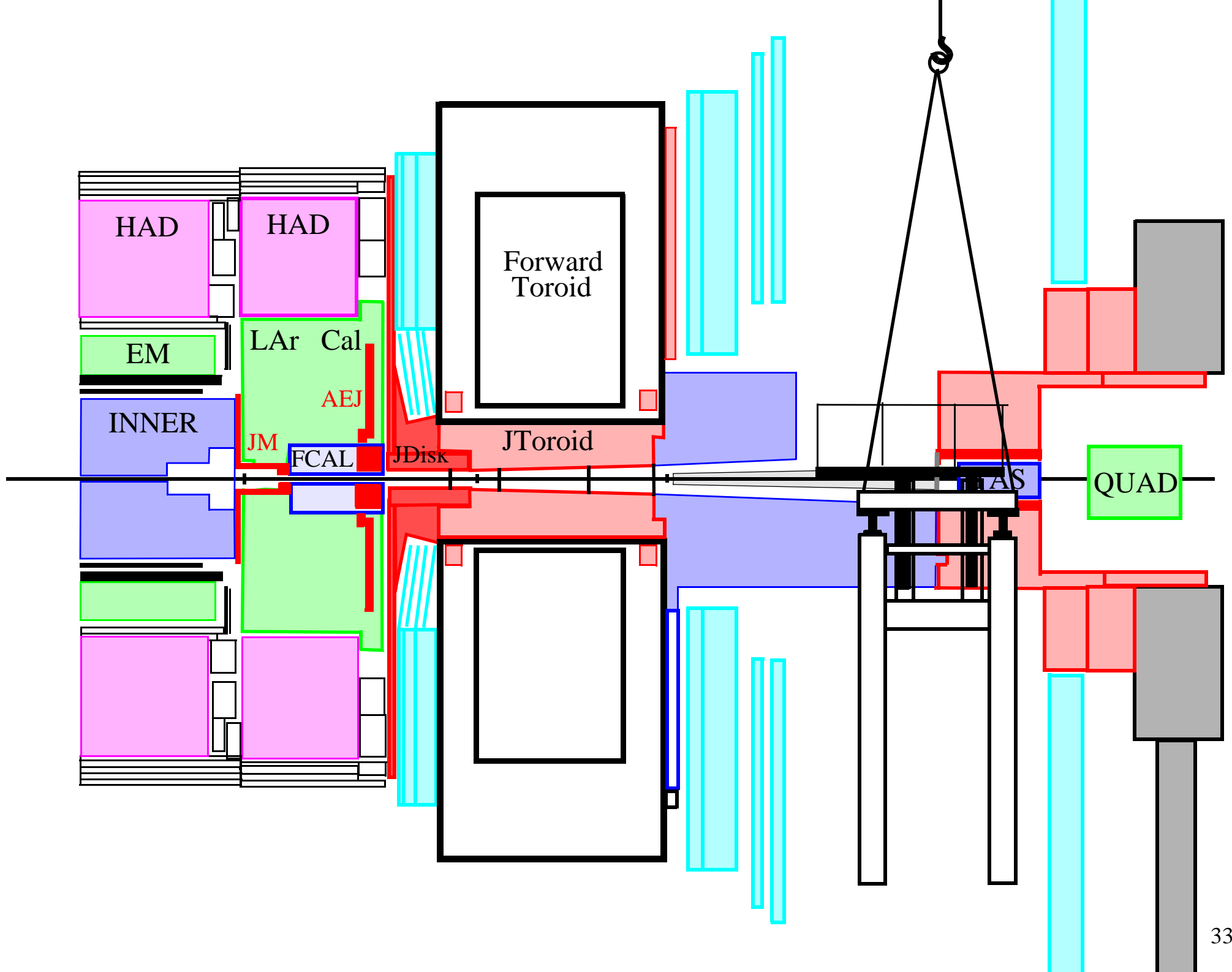

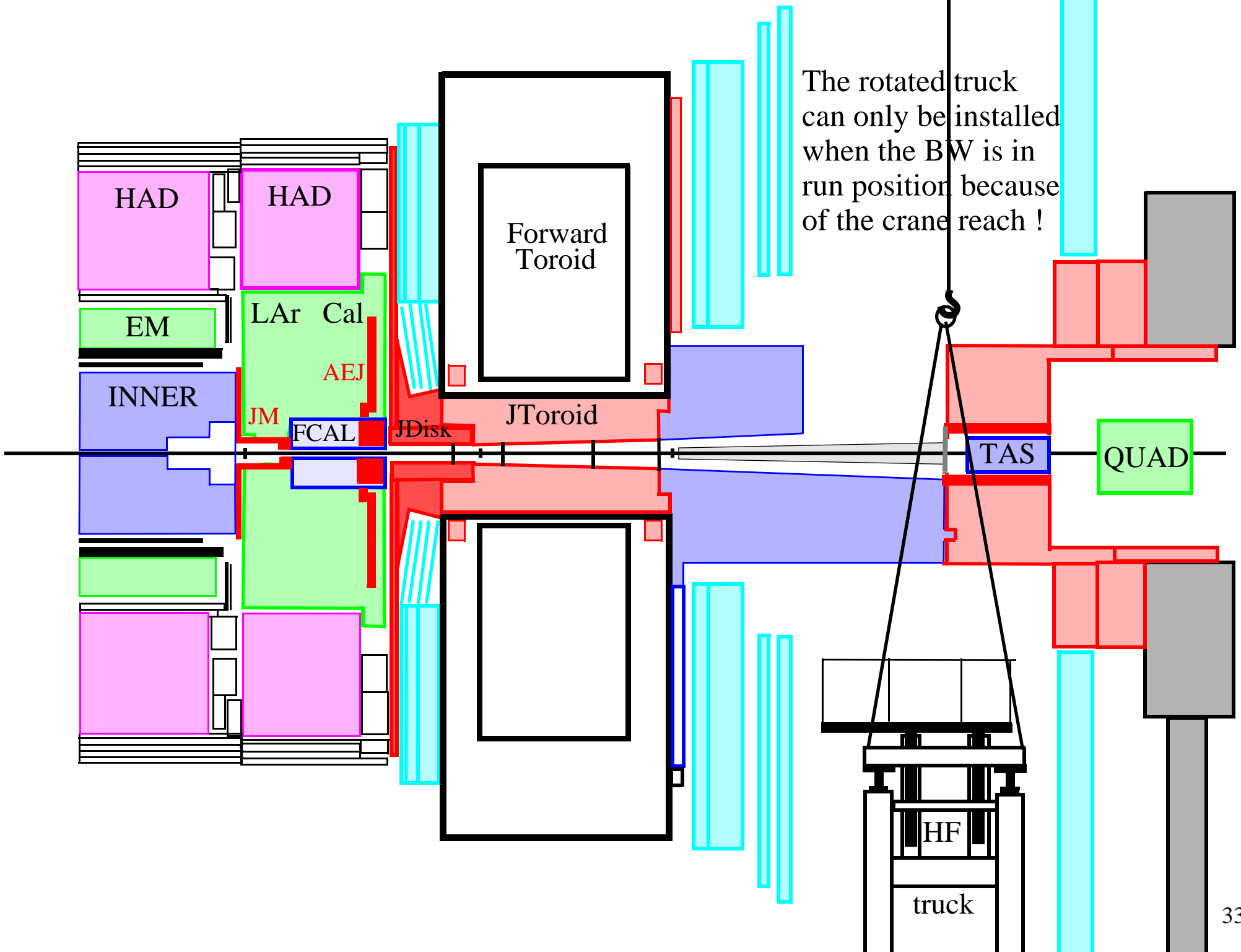

The rotated truck can only be installed when the BW is in run position because of the crane reach !

HF

truck

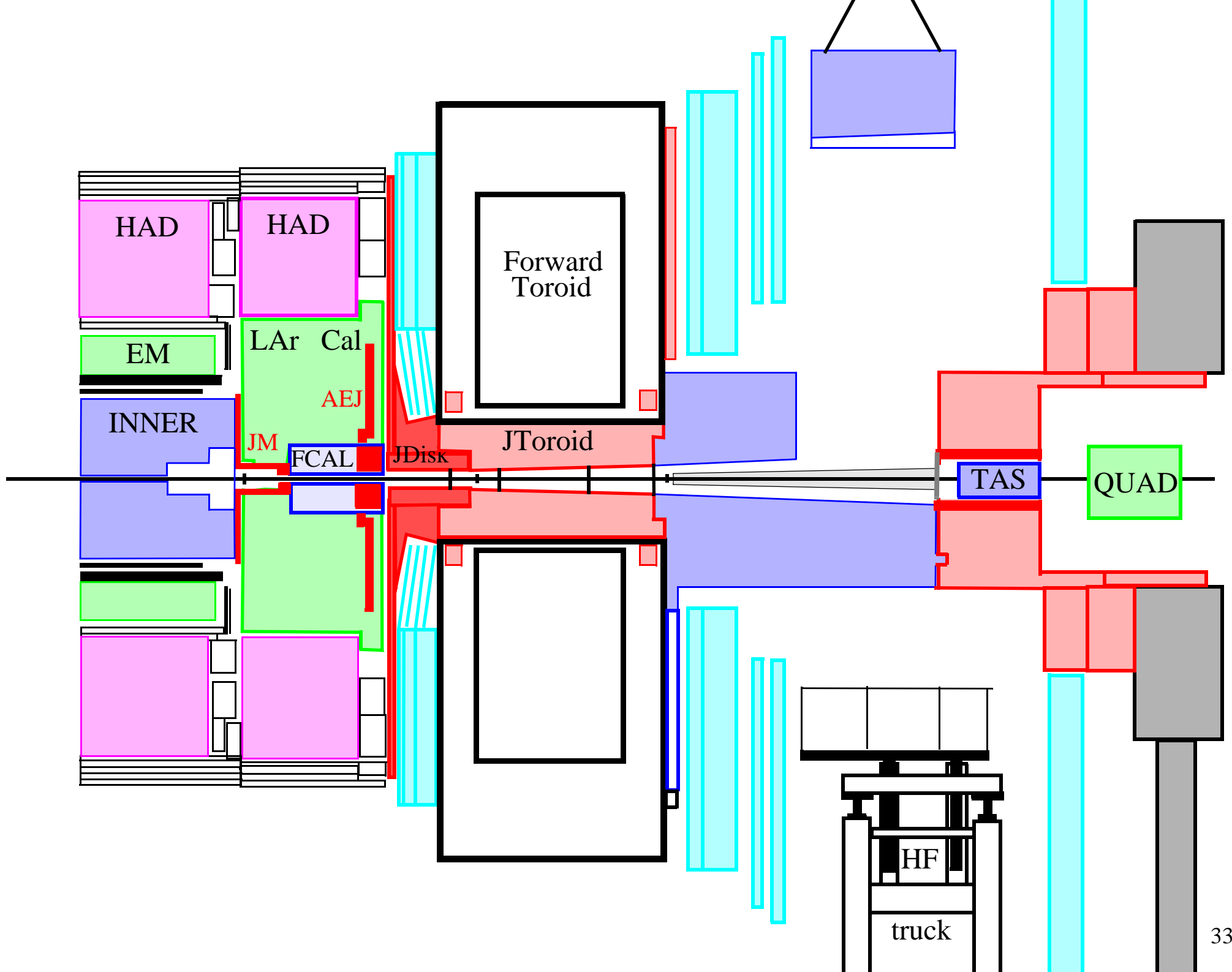

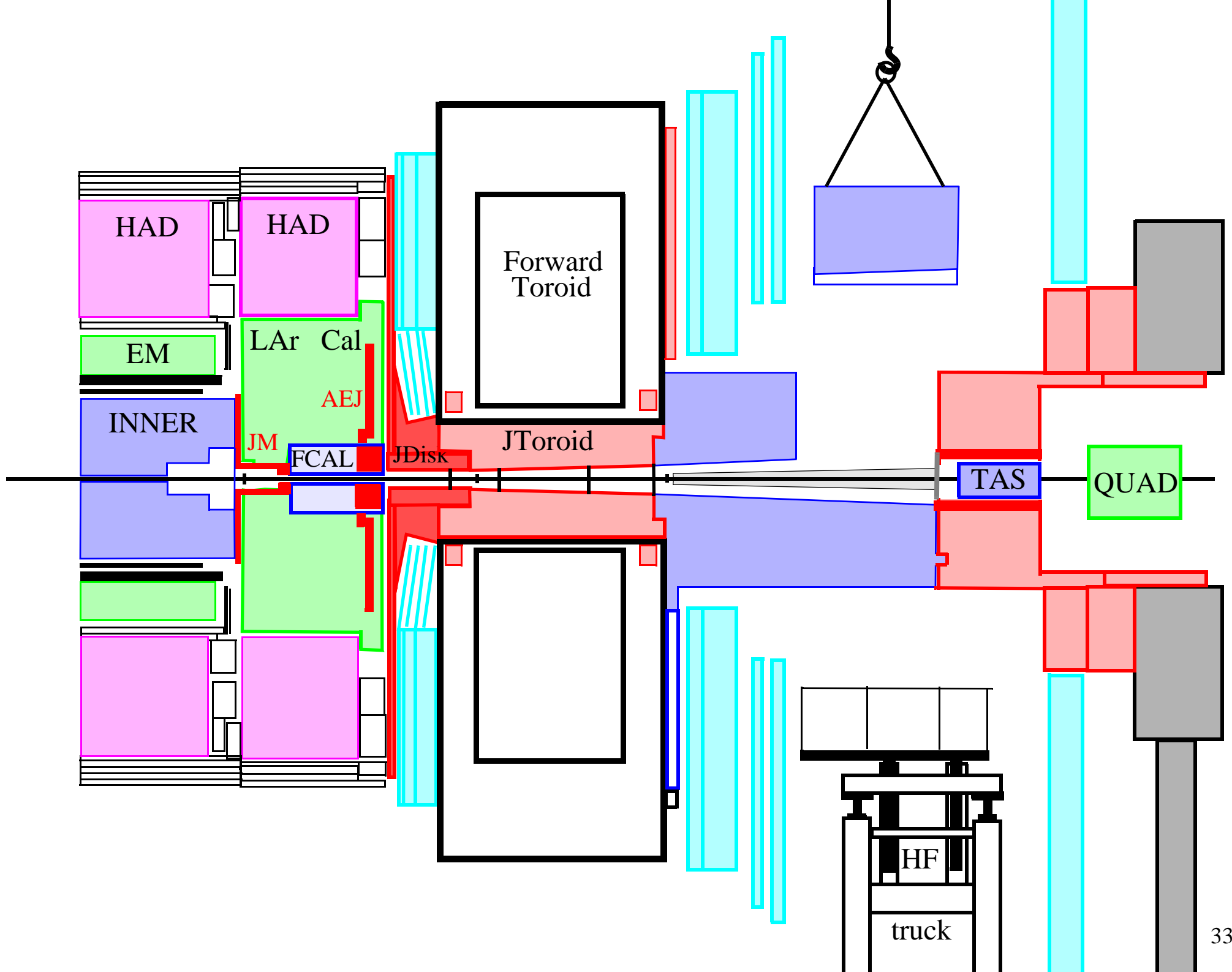

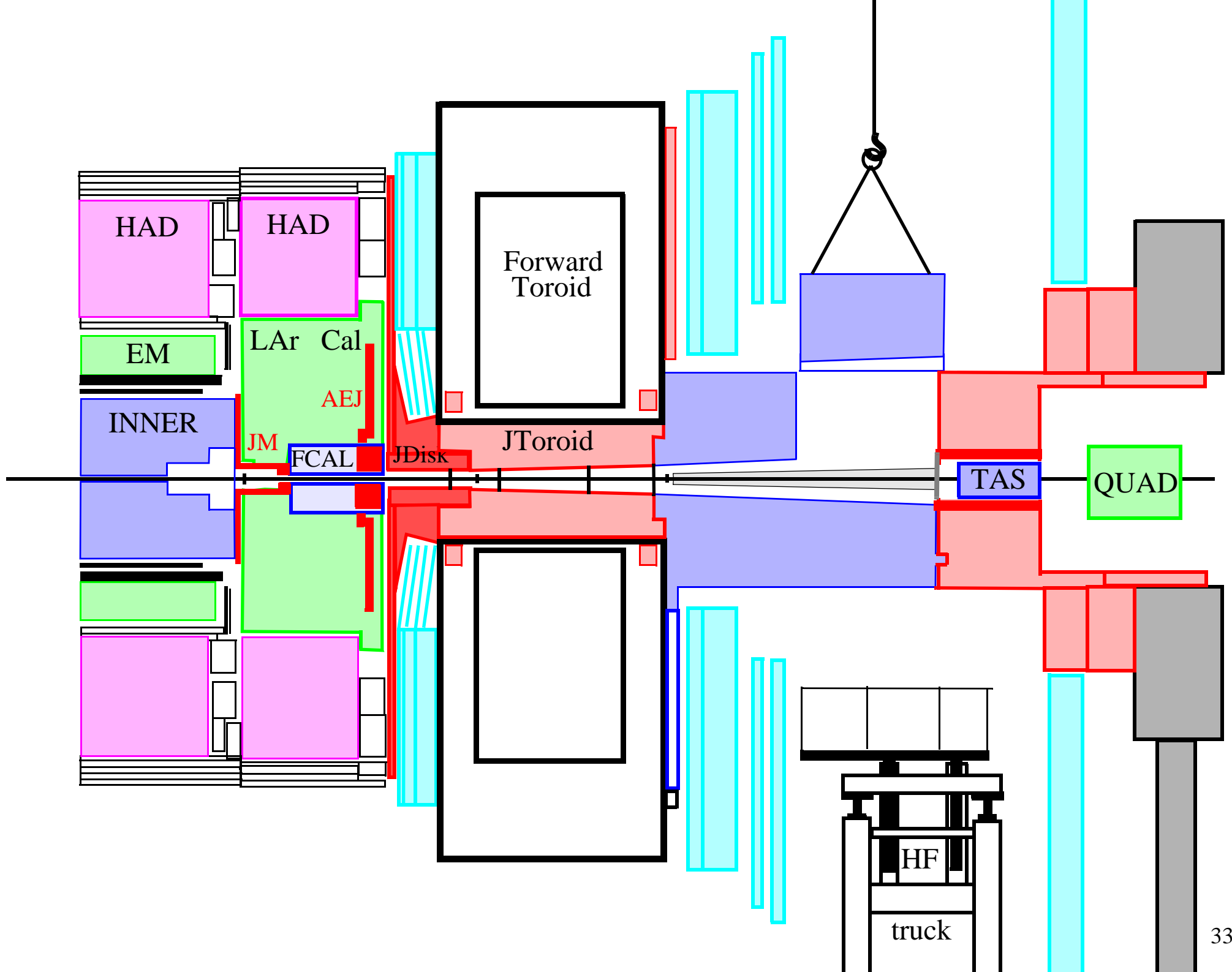

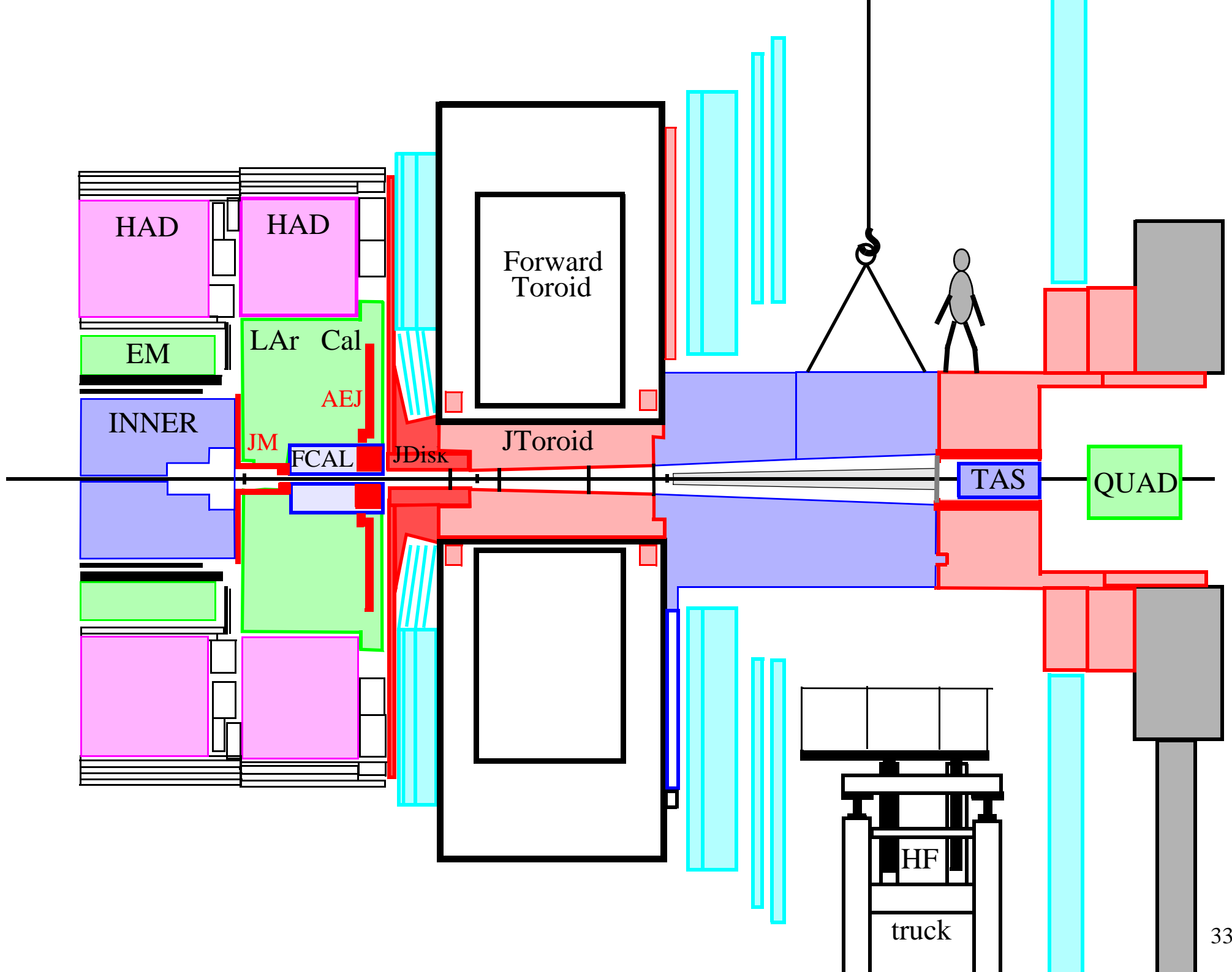

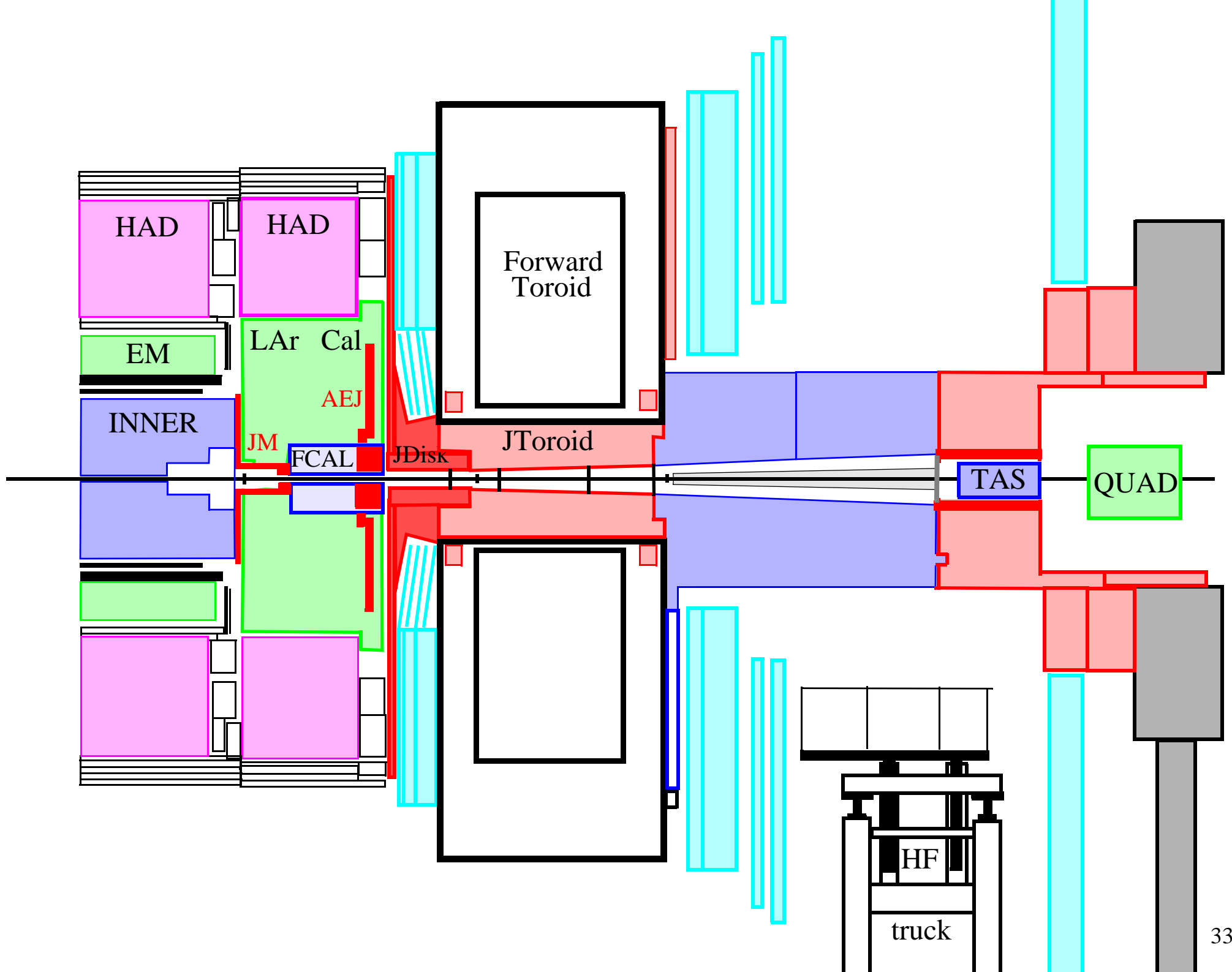

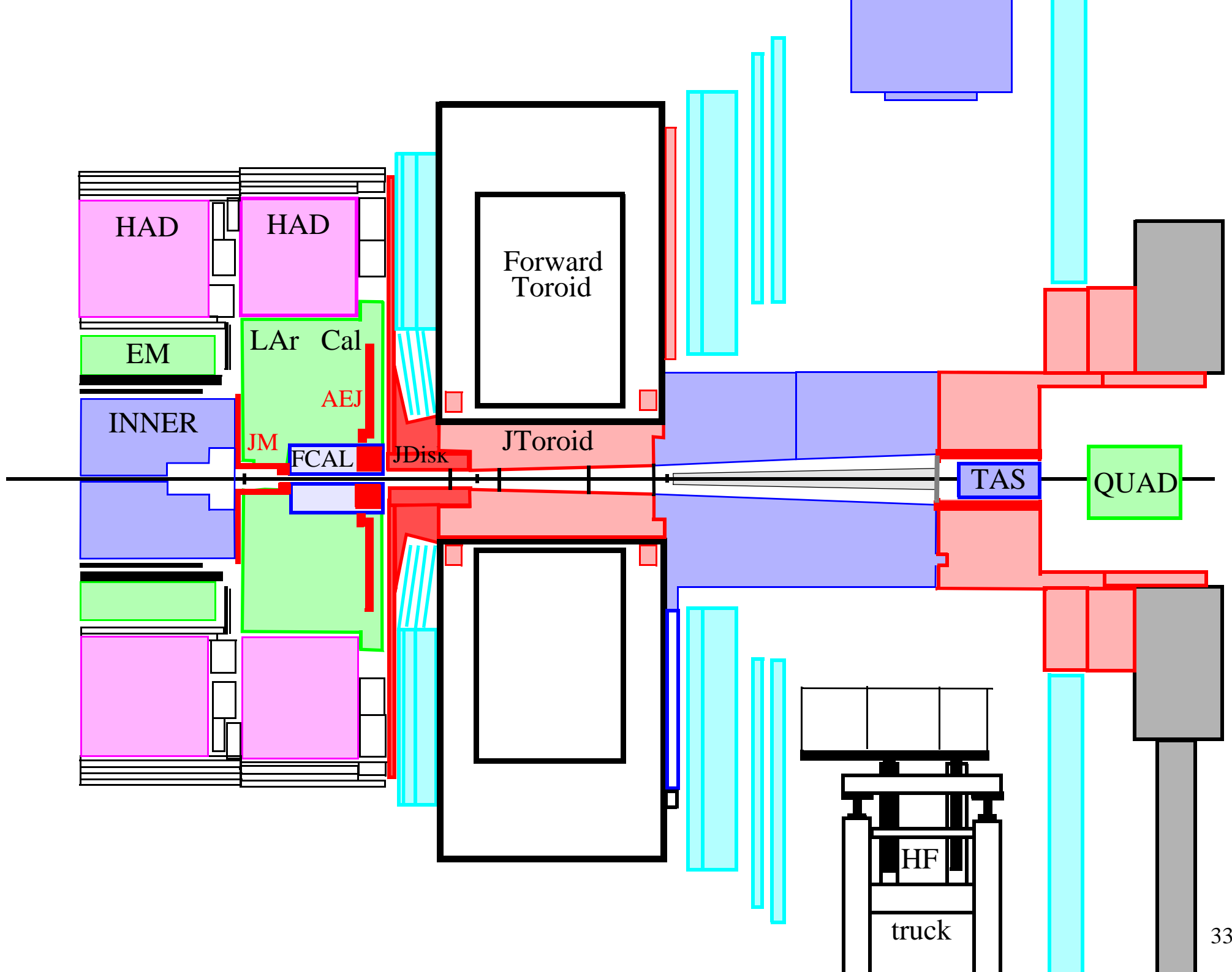

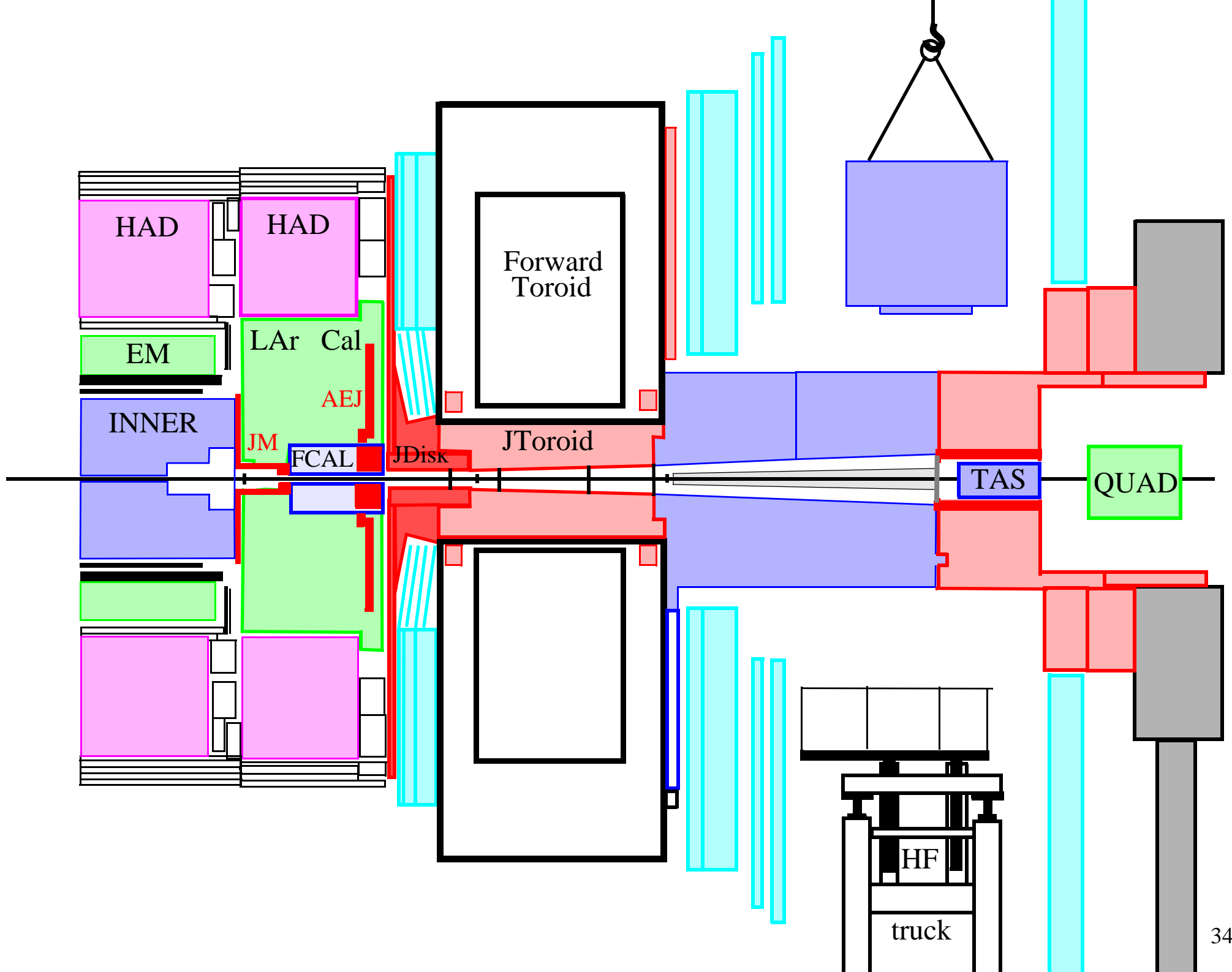

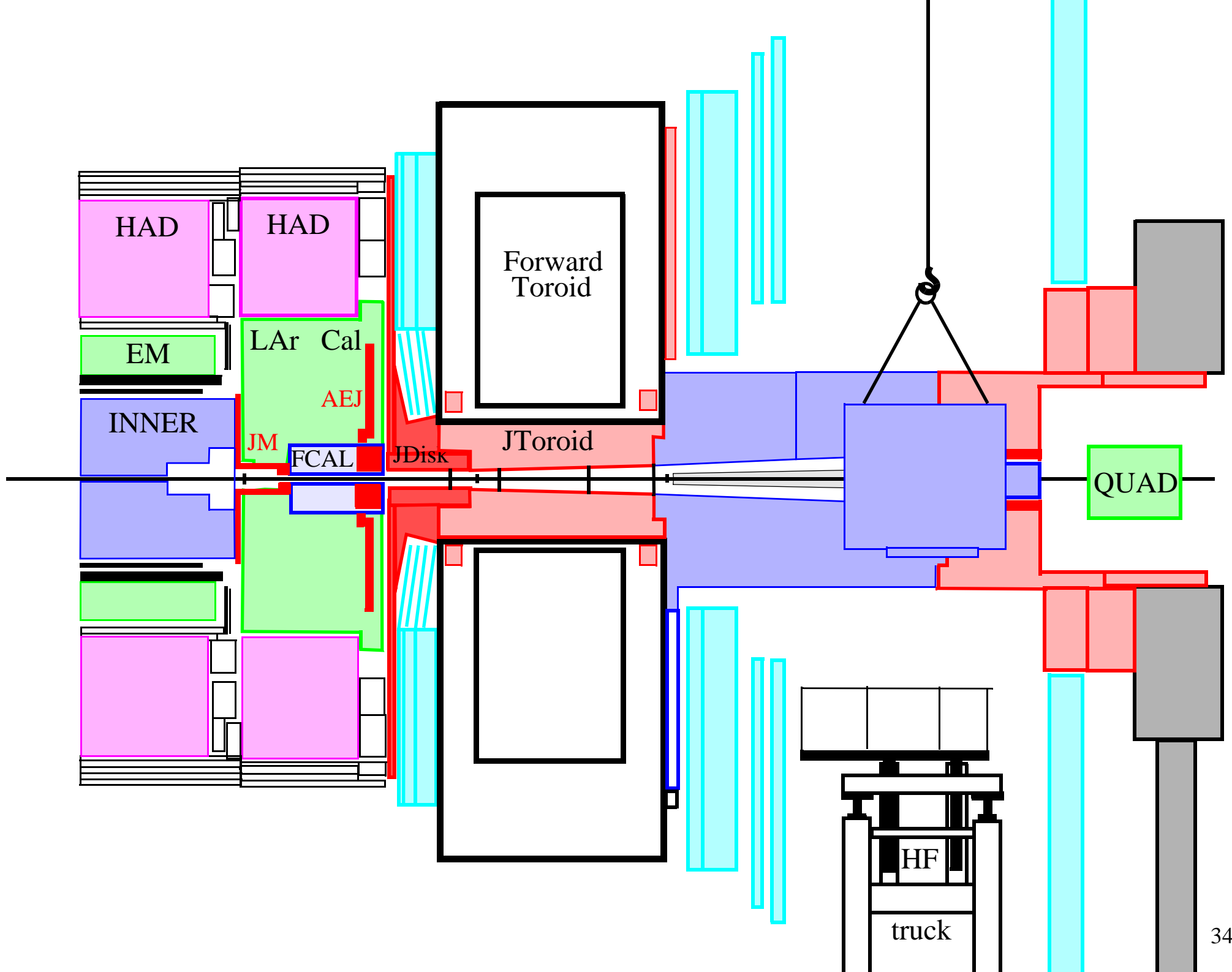

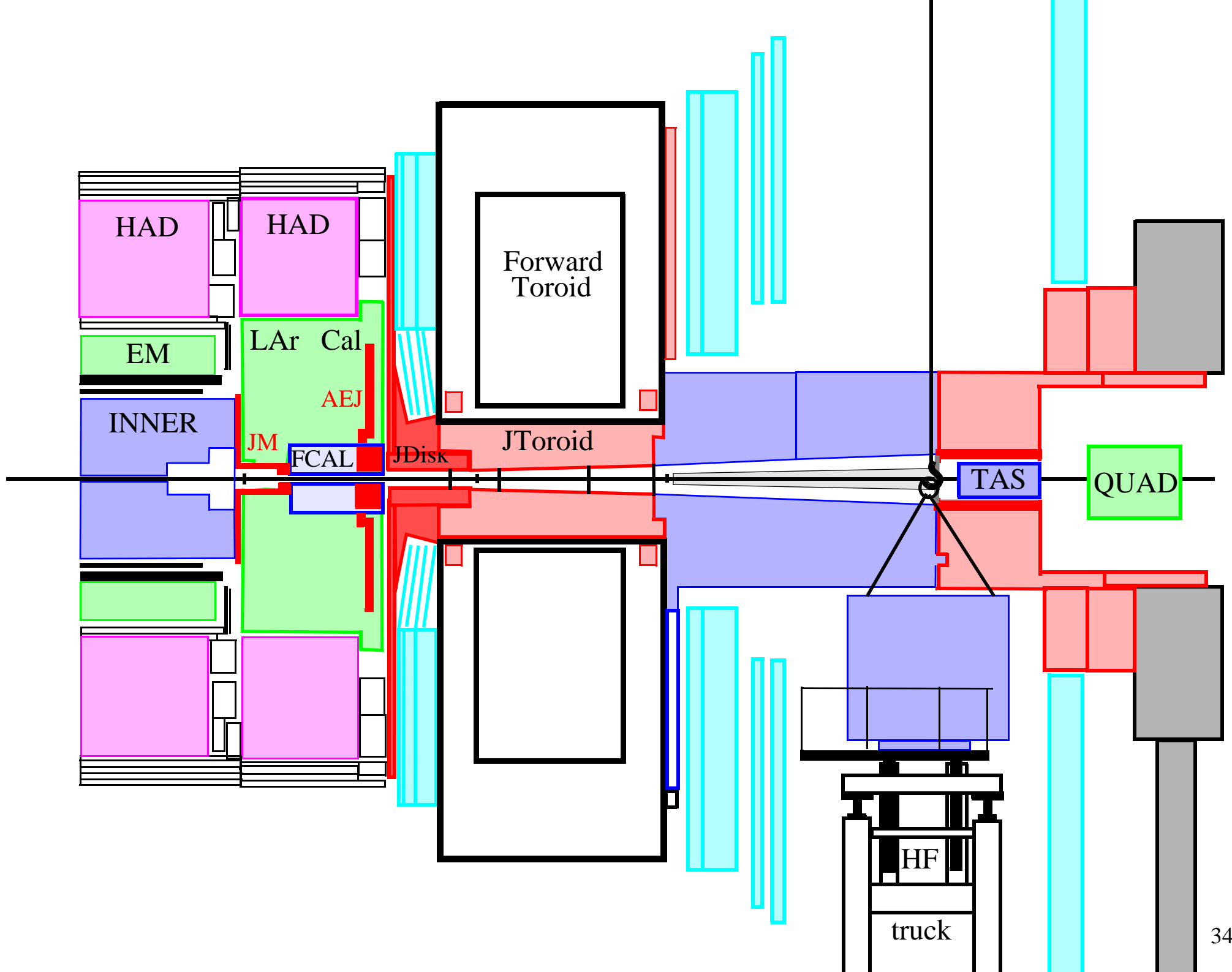

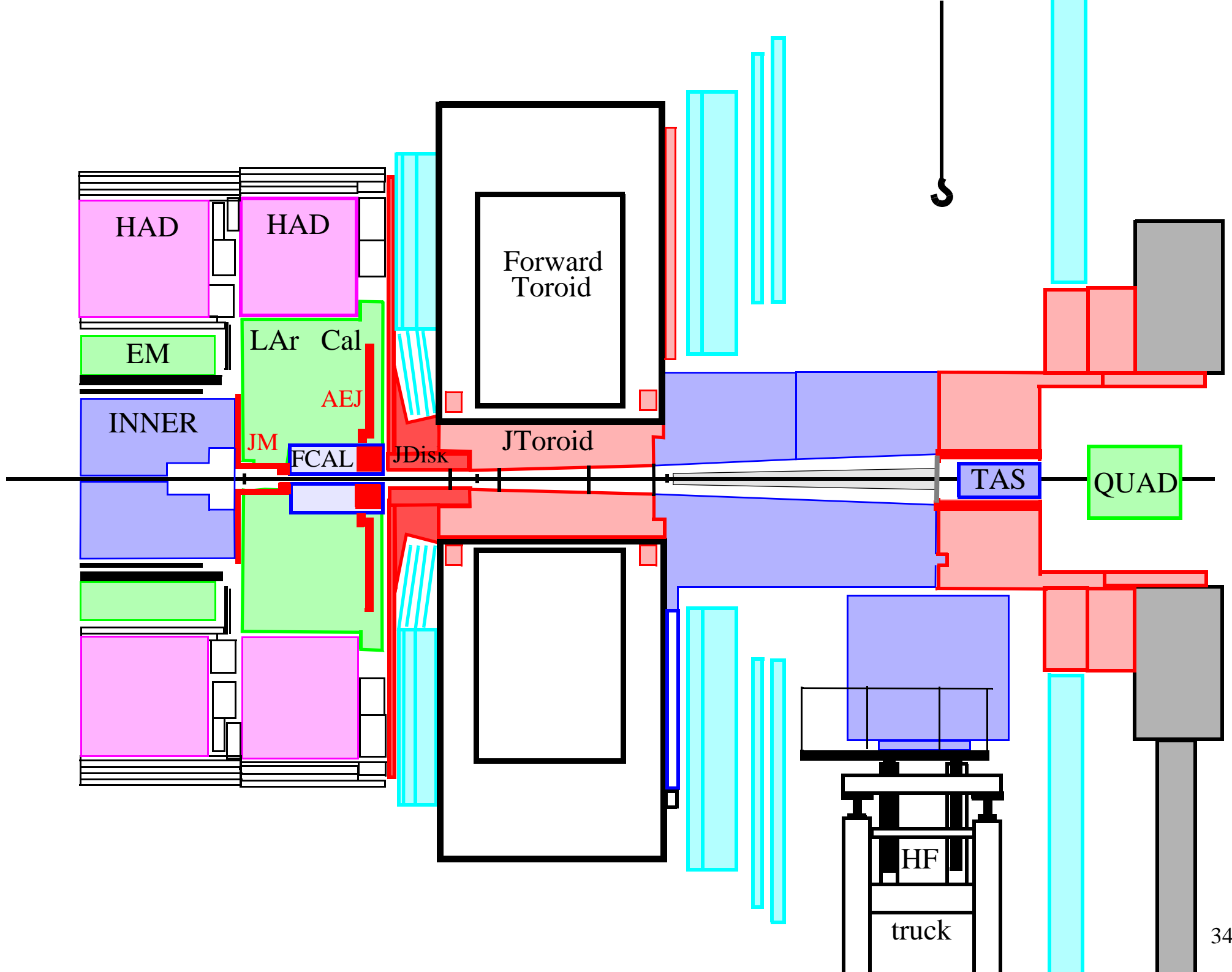

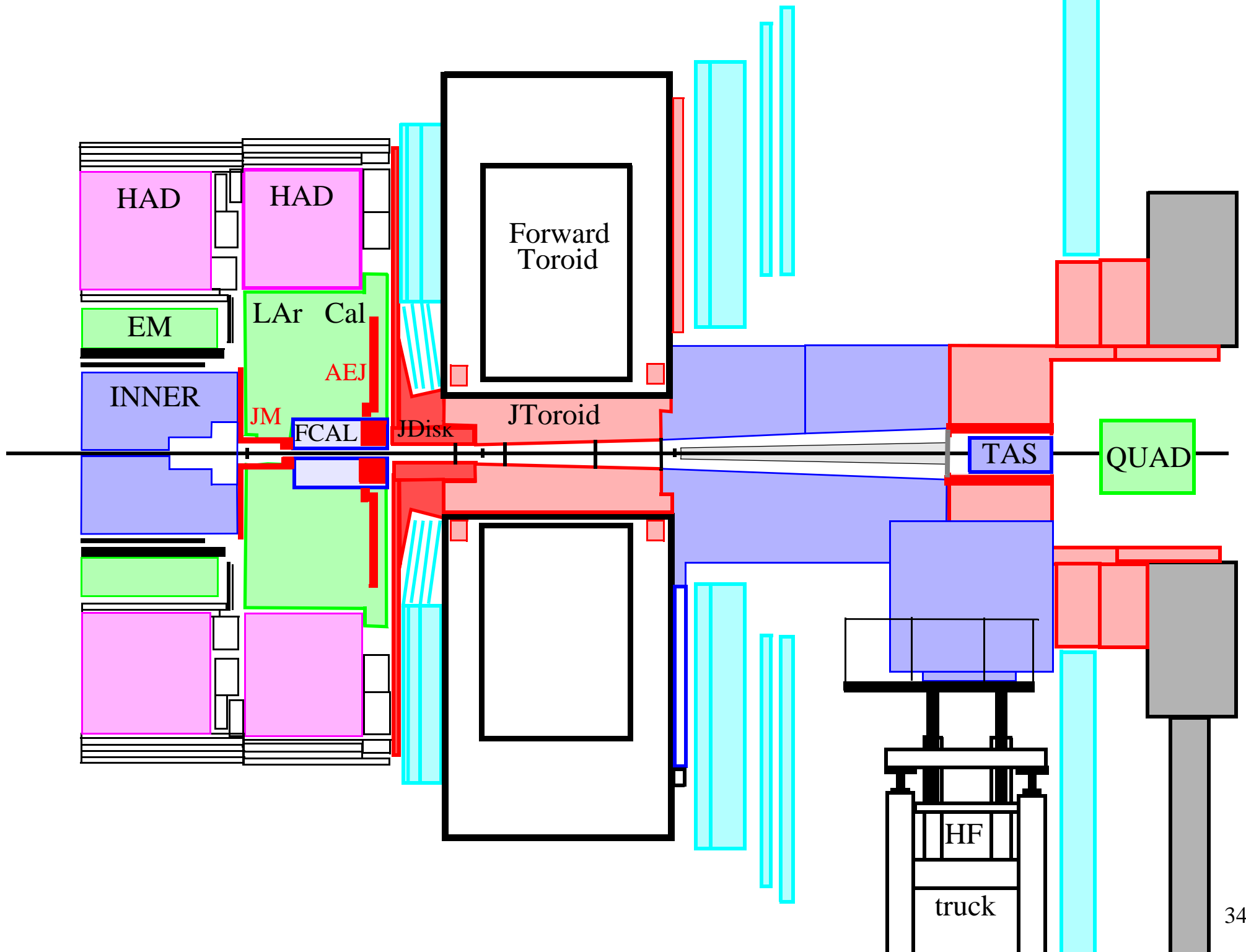

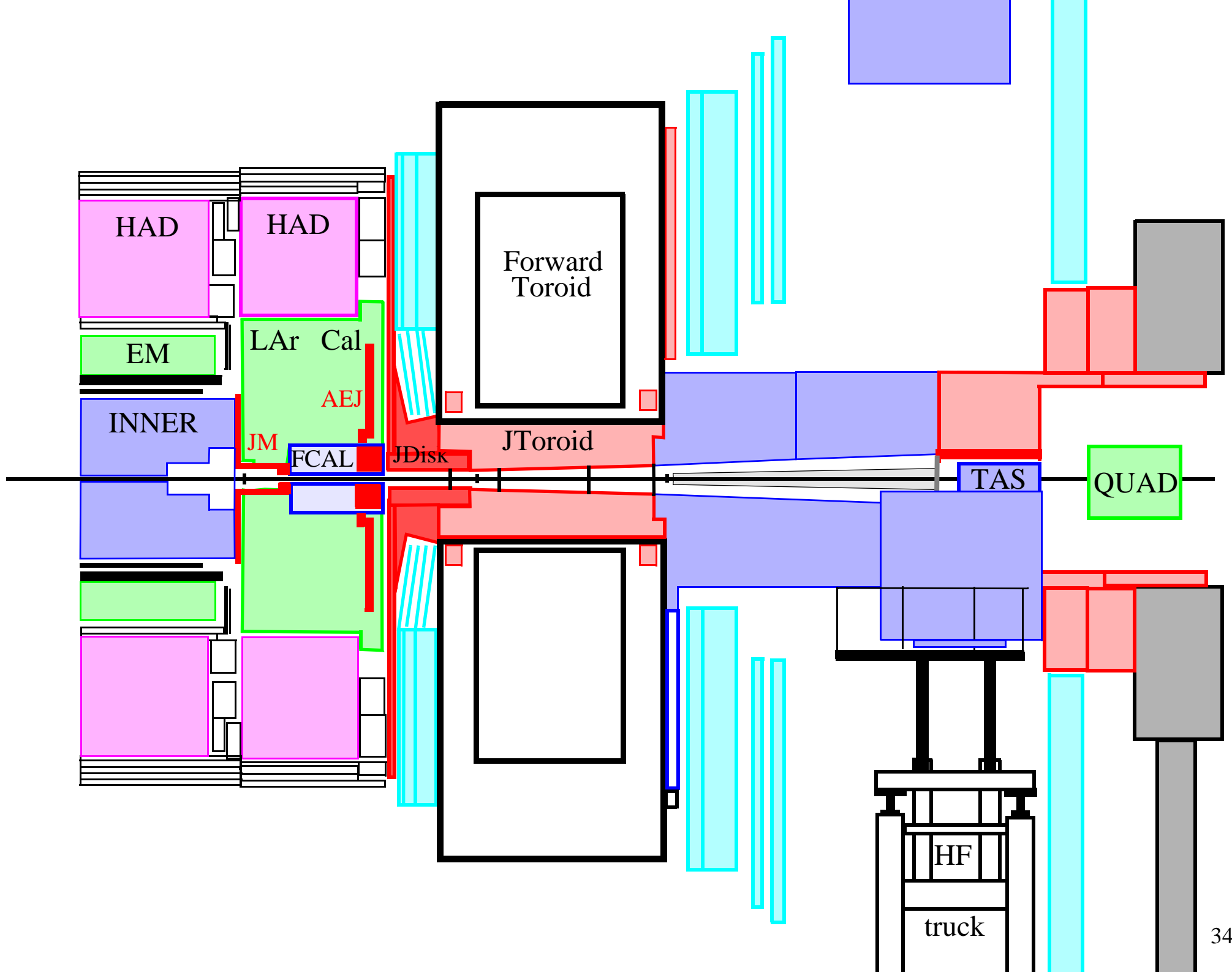

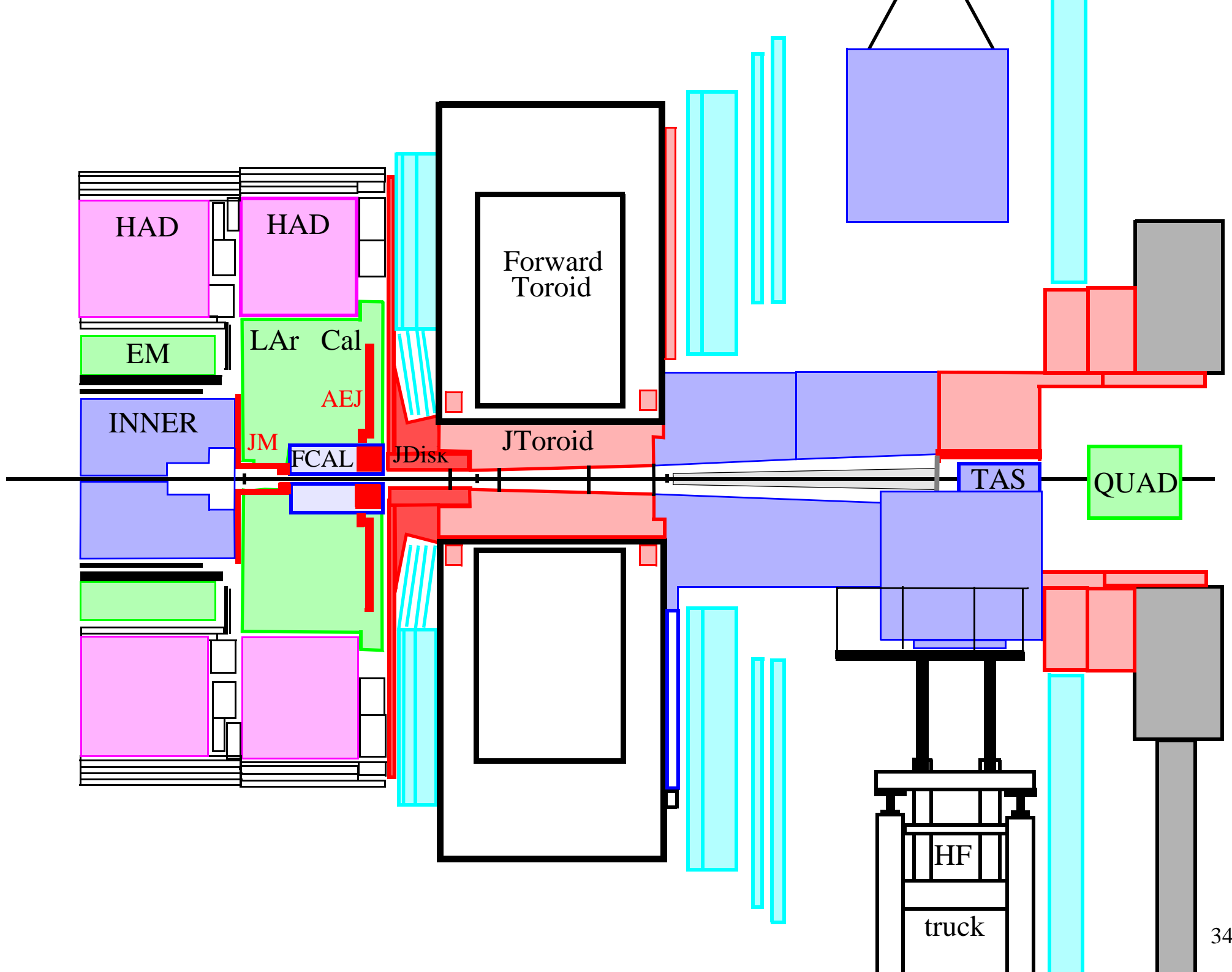

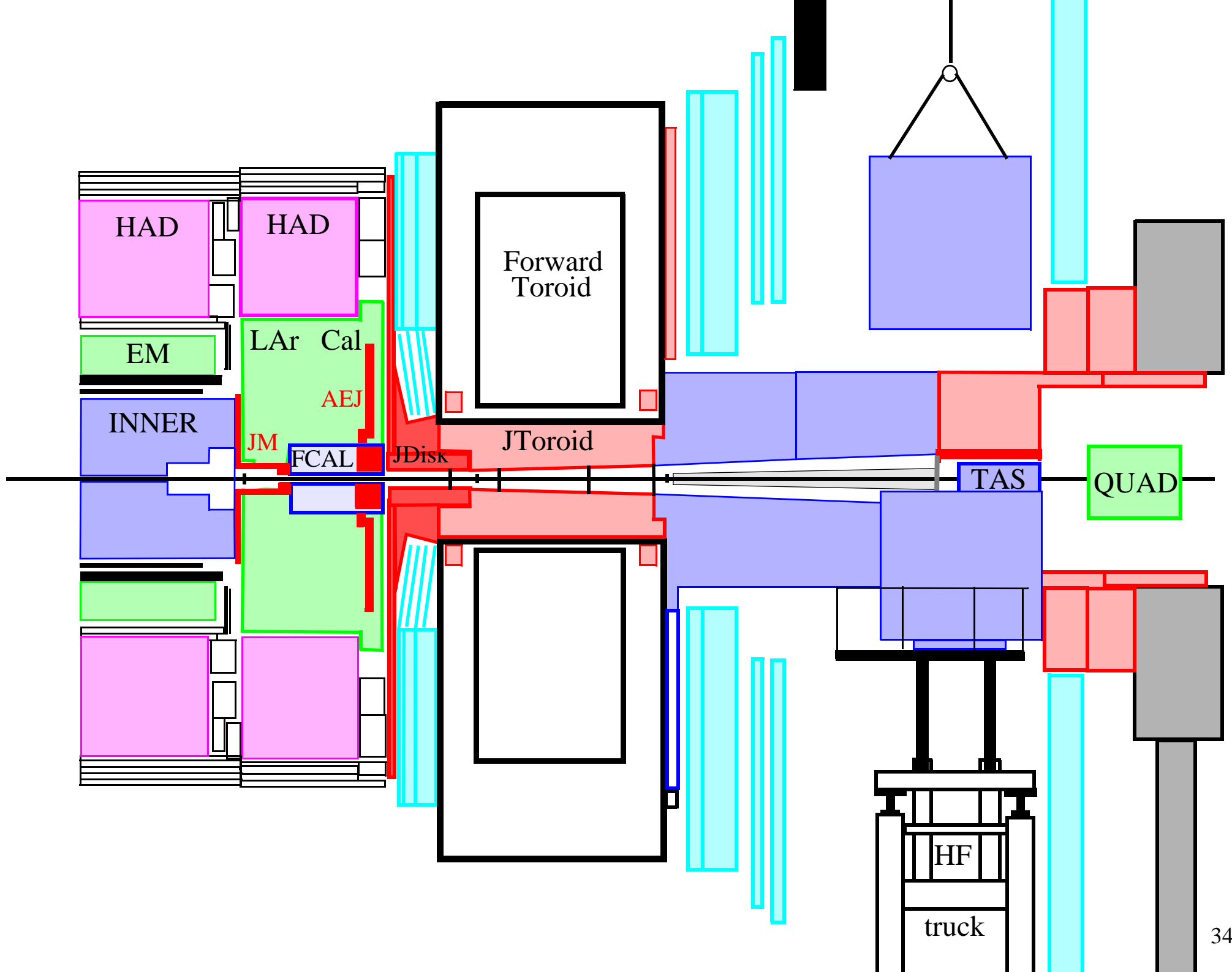

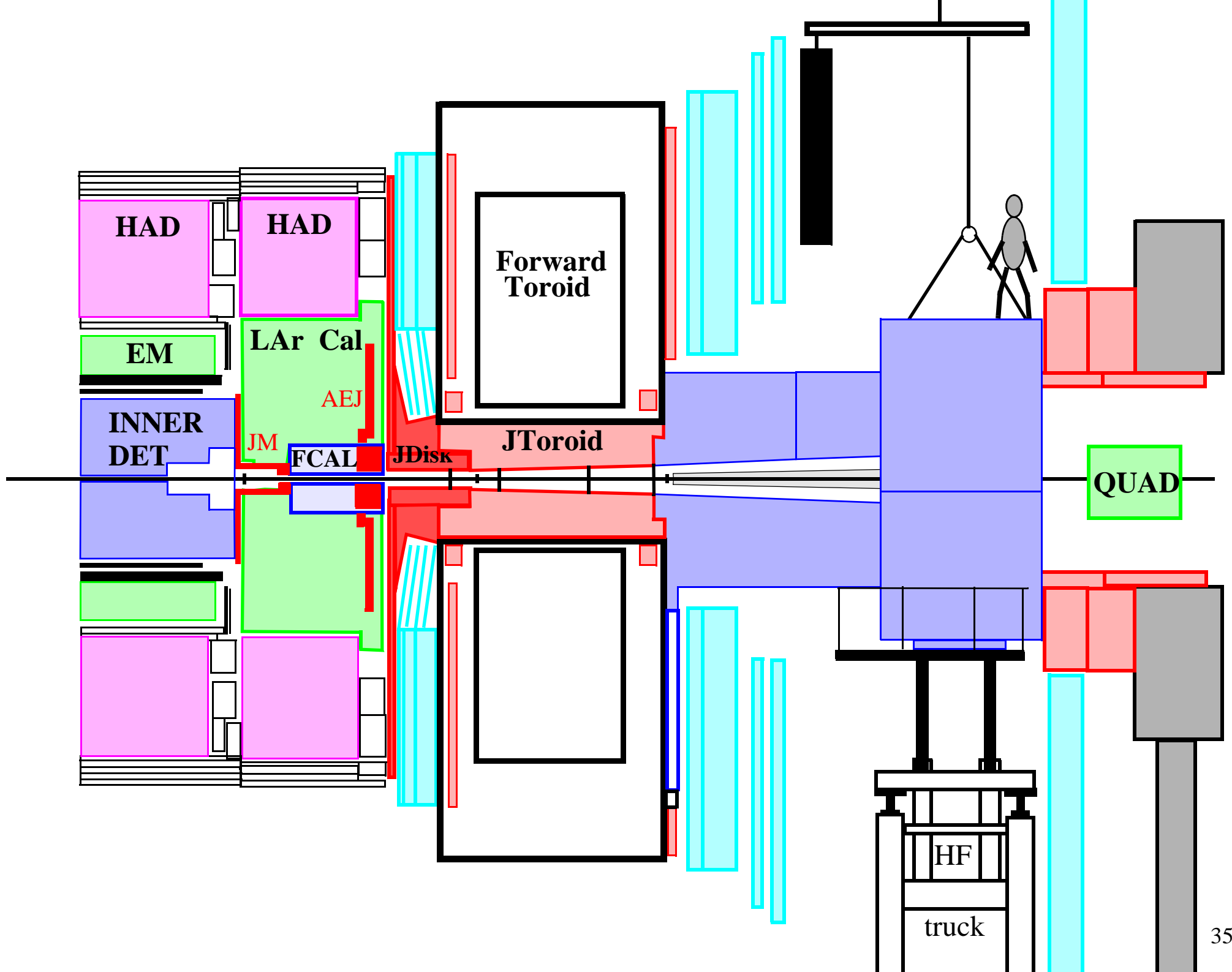

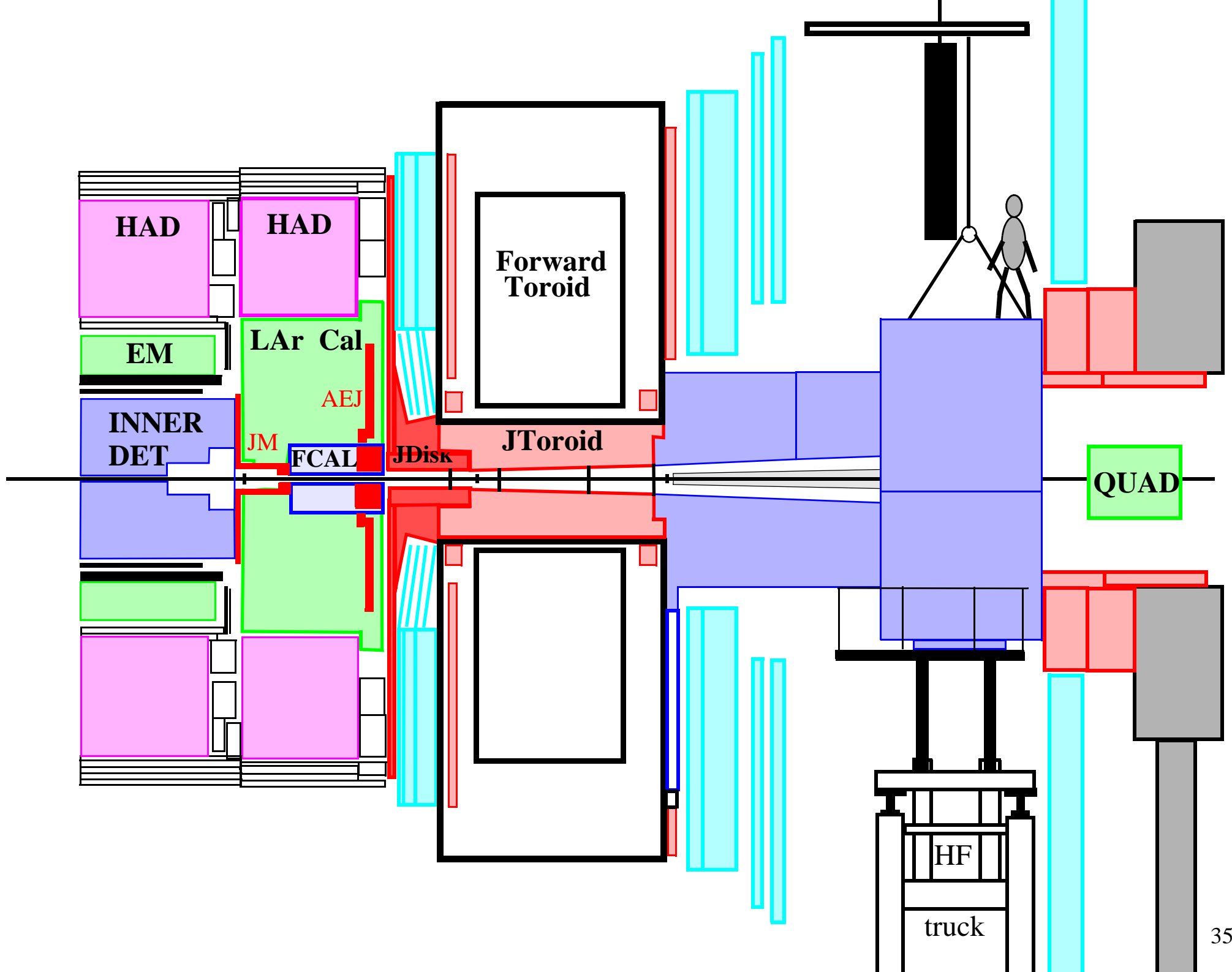

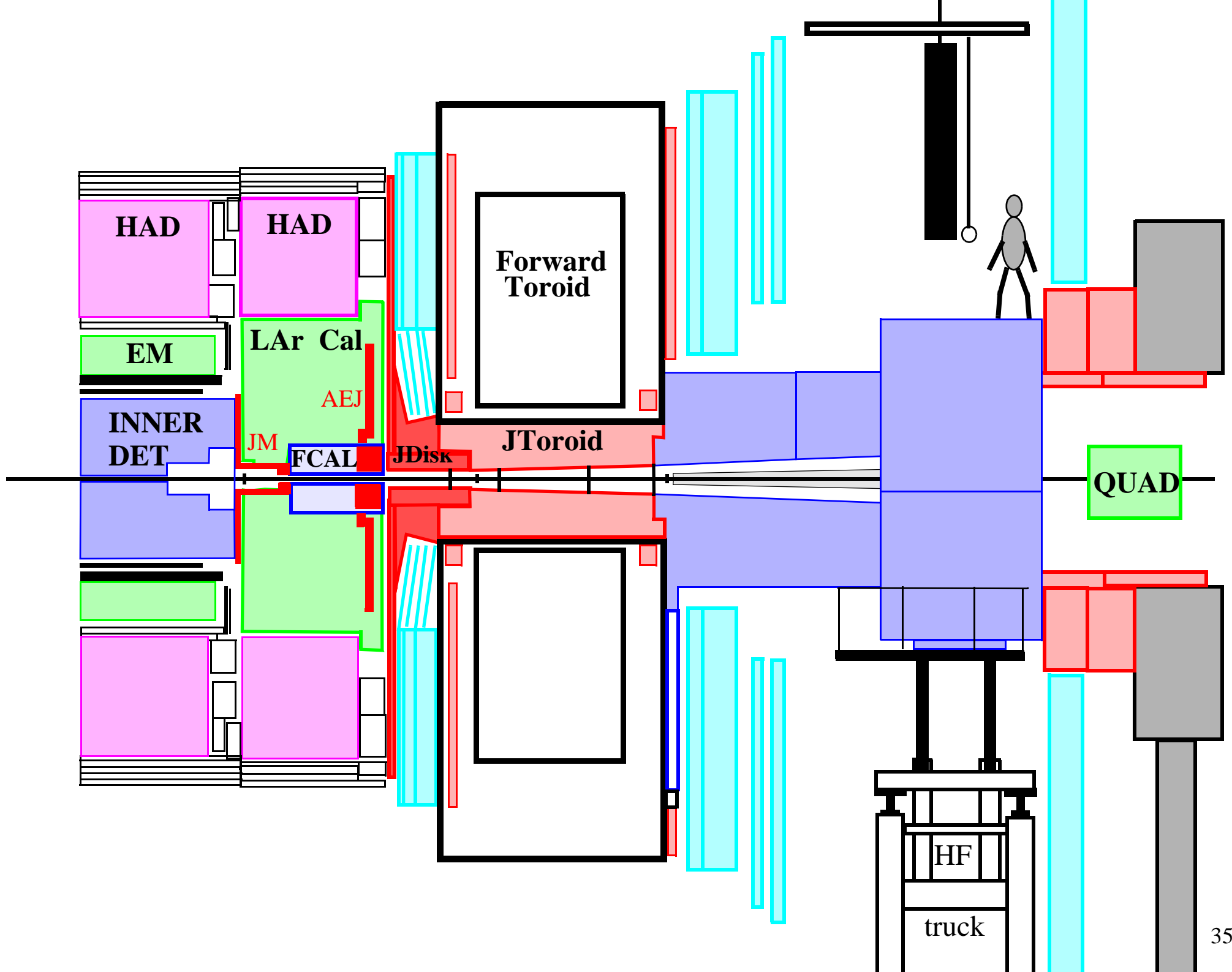

August 2007

