

May 2006

Side C

The scenario starts with the installation of the Big Wheel TGC1 in May 2006 !

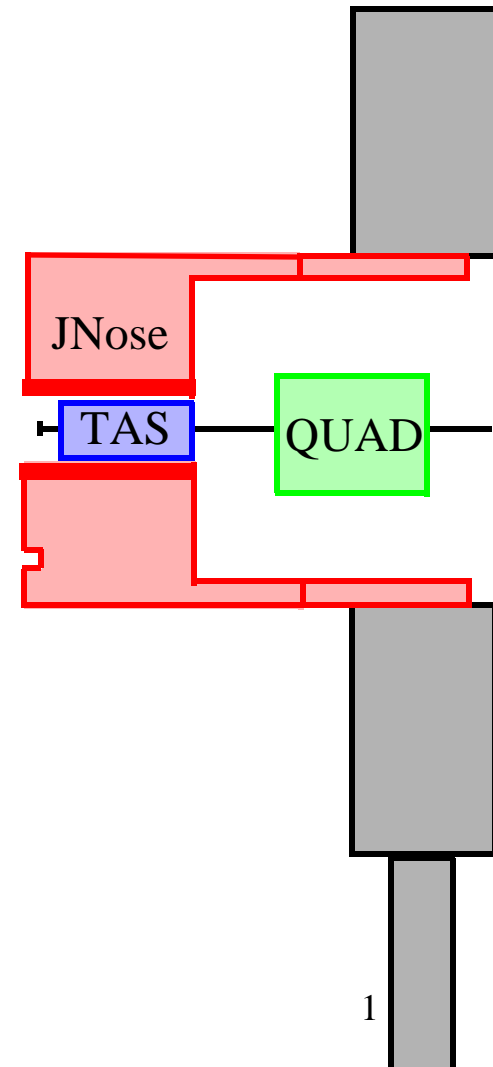

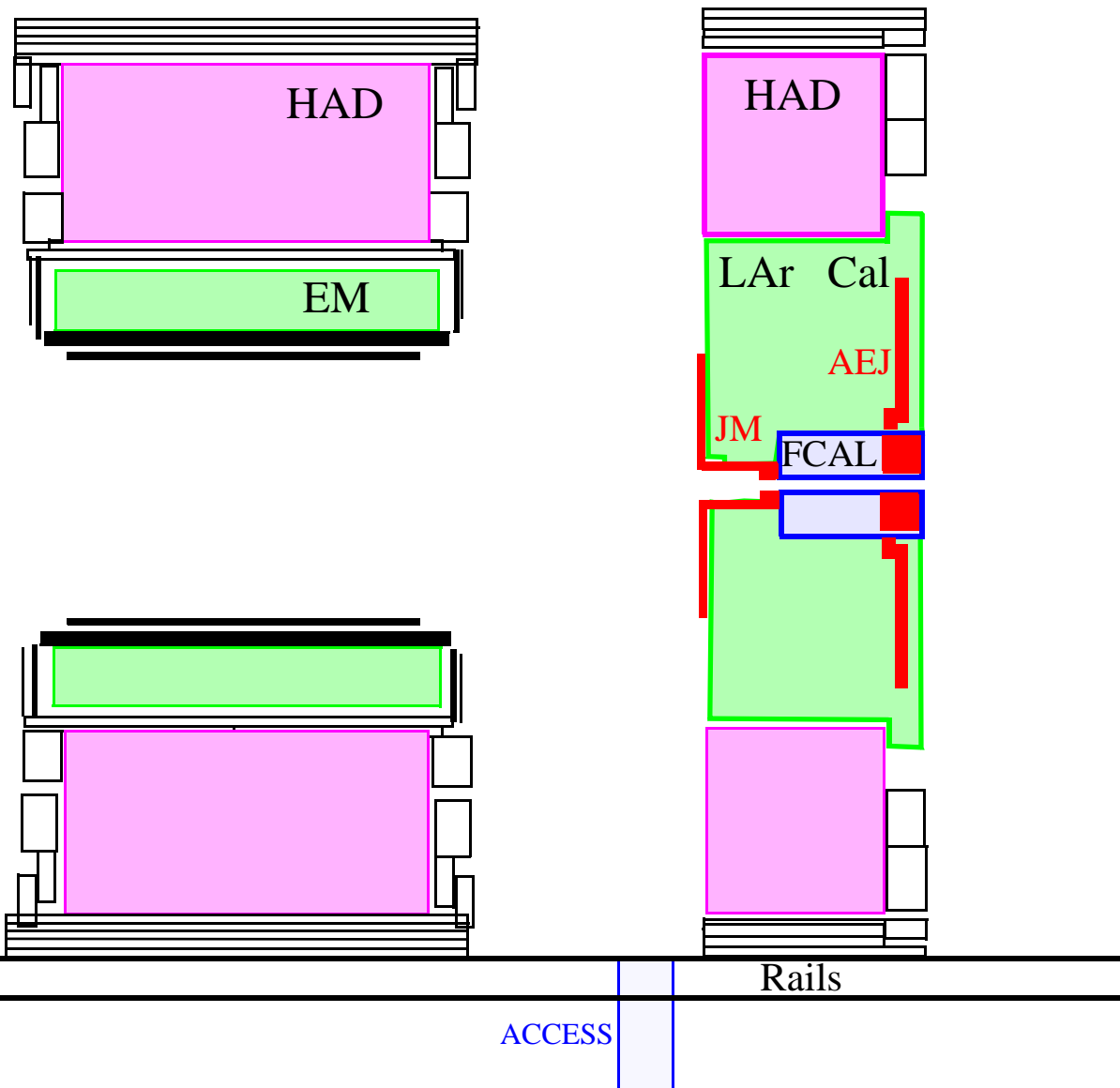
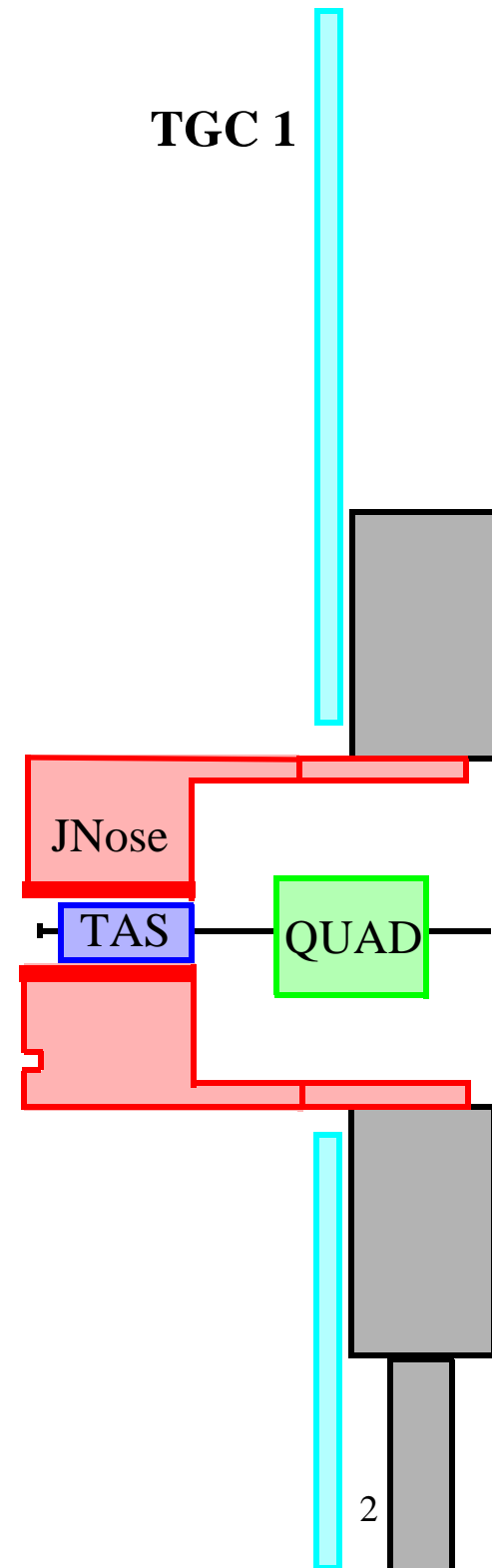
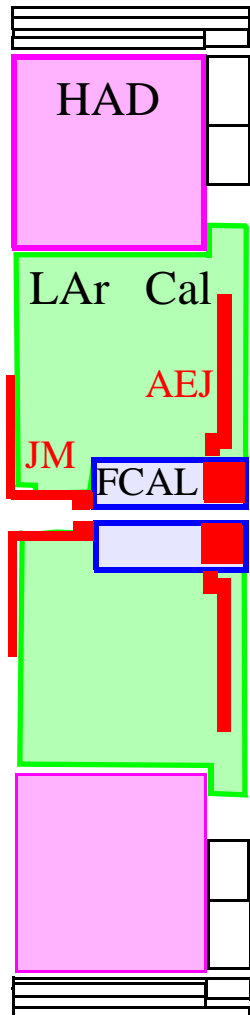

ACCESS

Rails

2

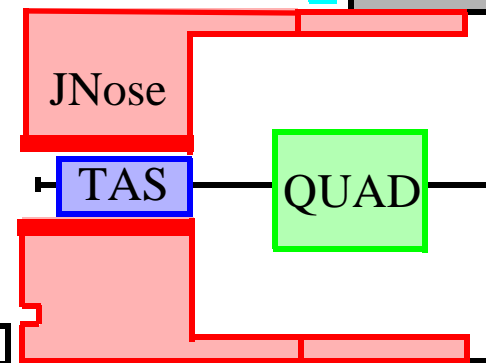
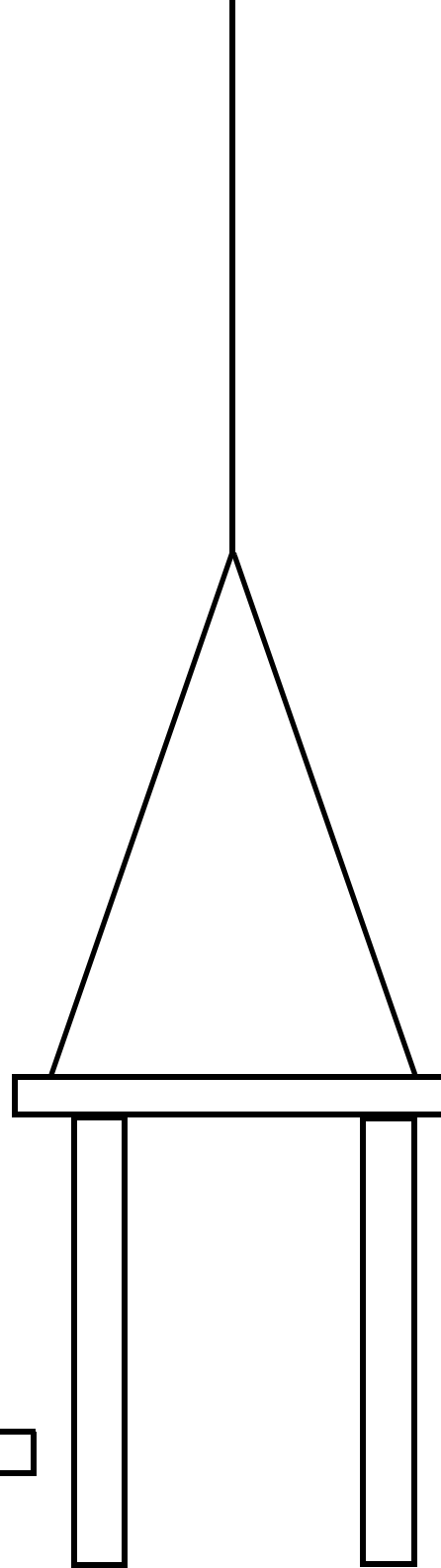
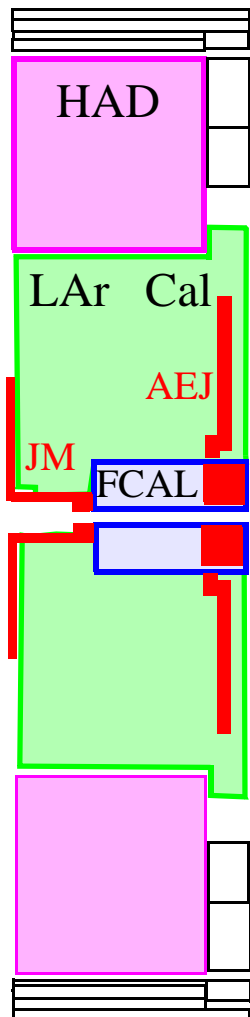
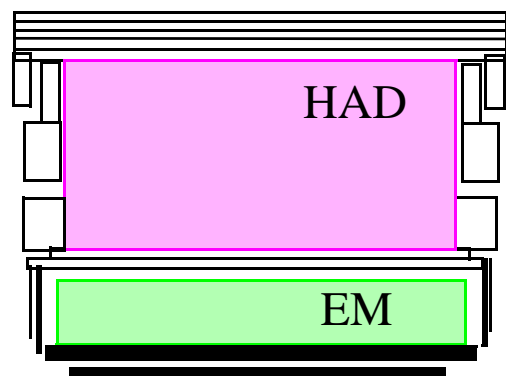

ACCESS

RAILS

3

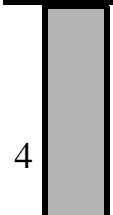
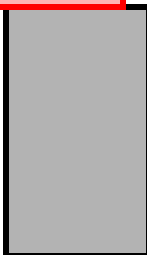
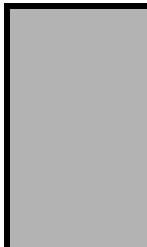
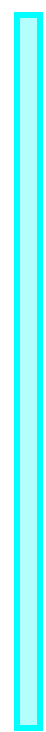
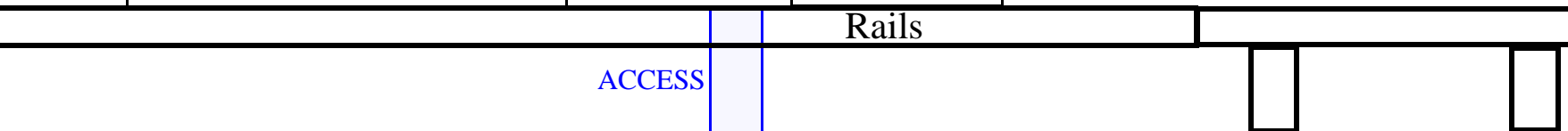
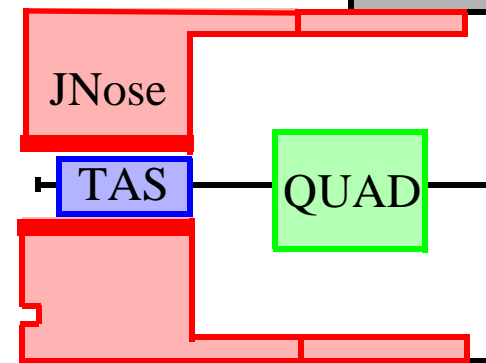
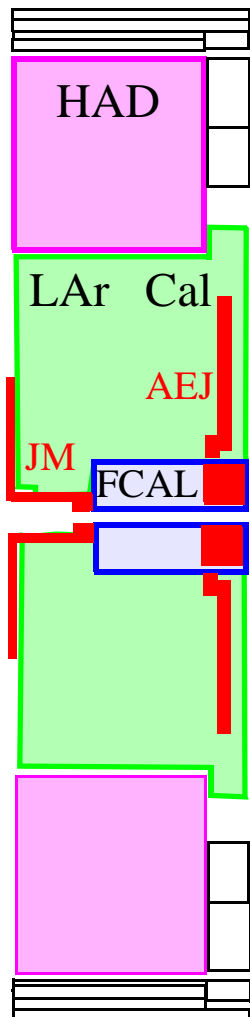
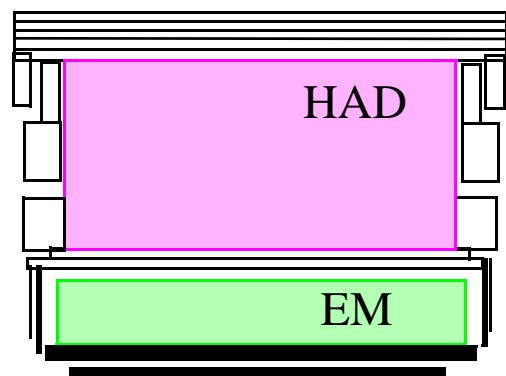

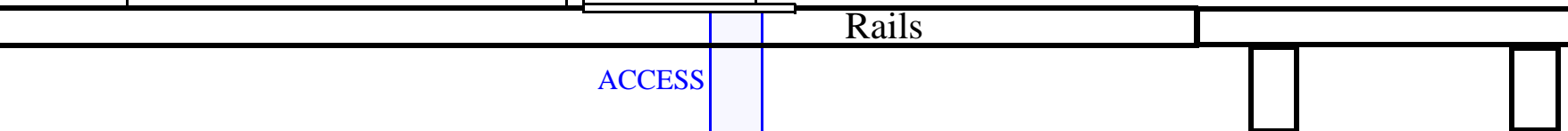
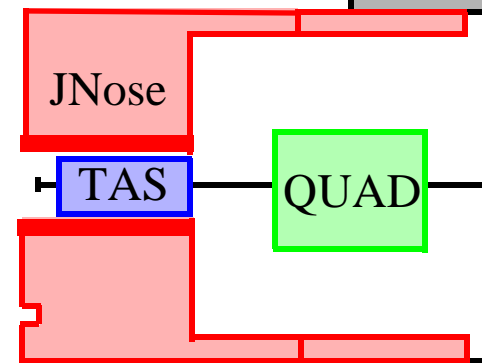
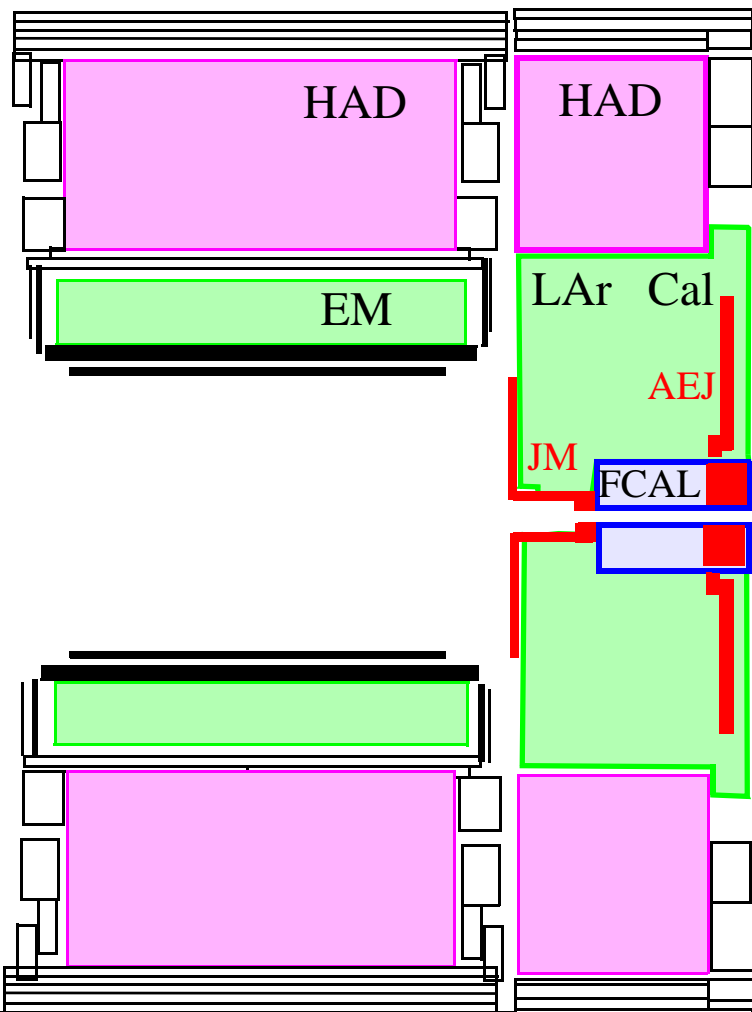

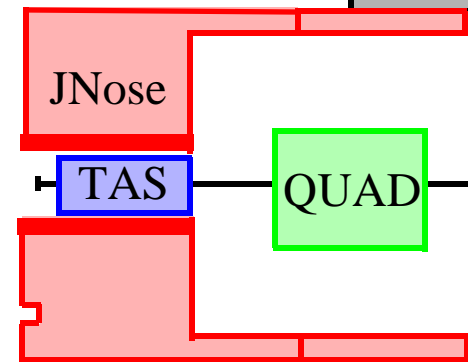
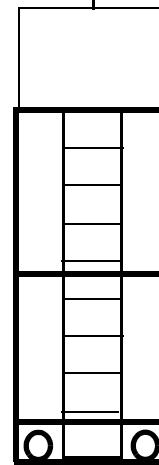
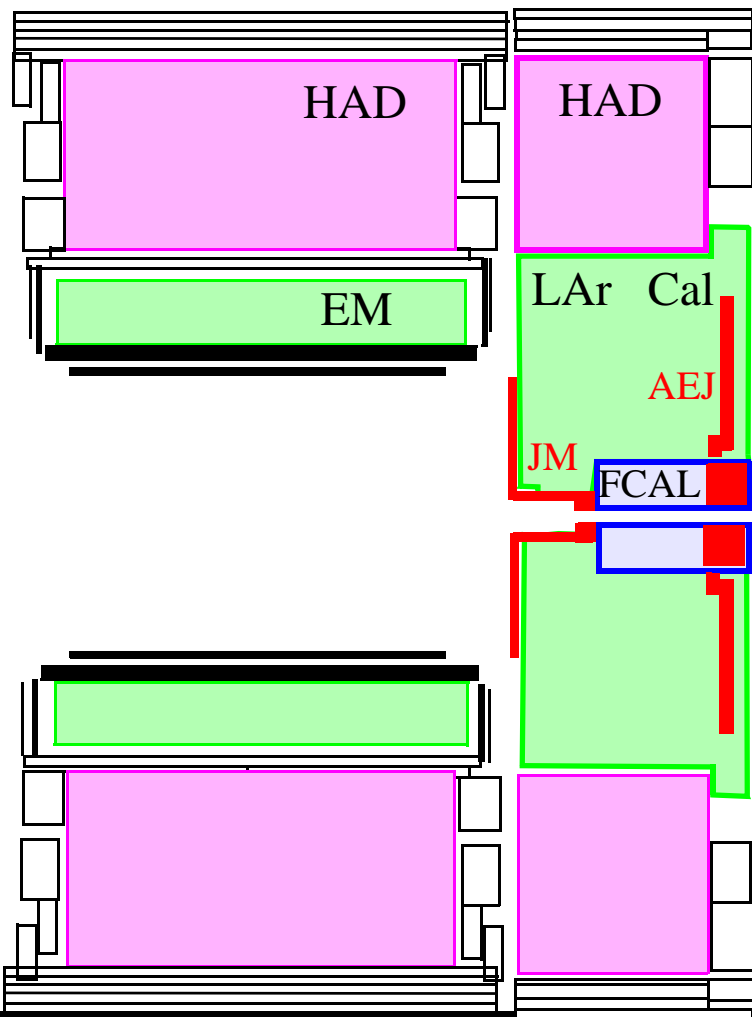

Rails

ACCESS

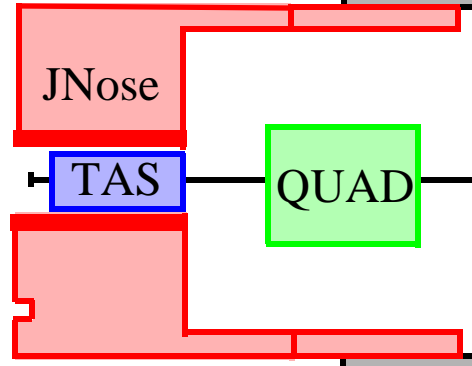
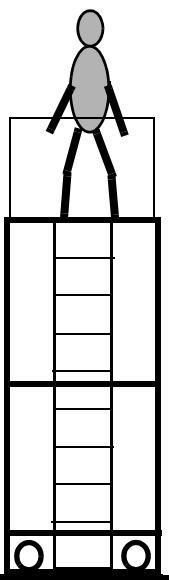
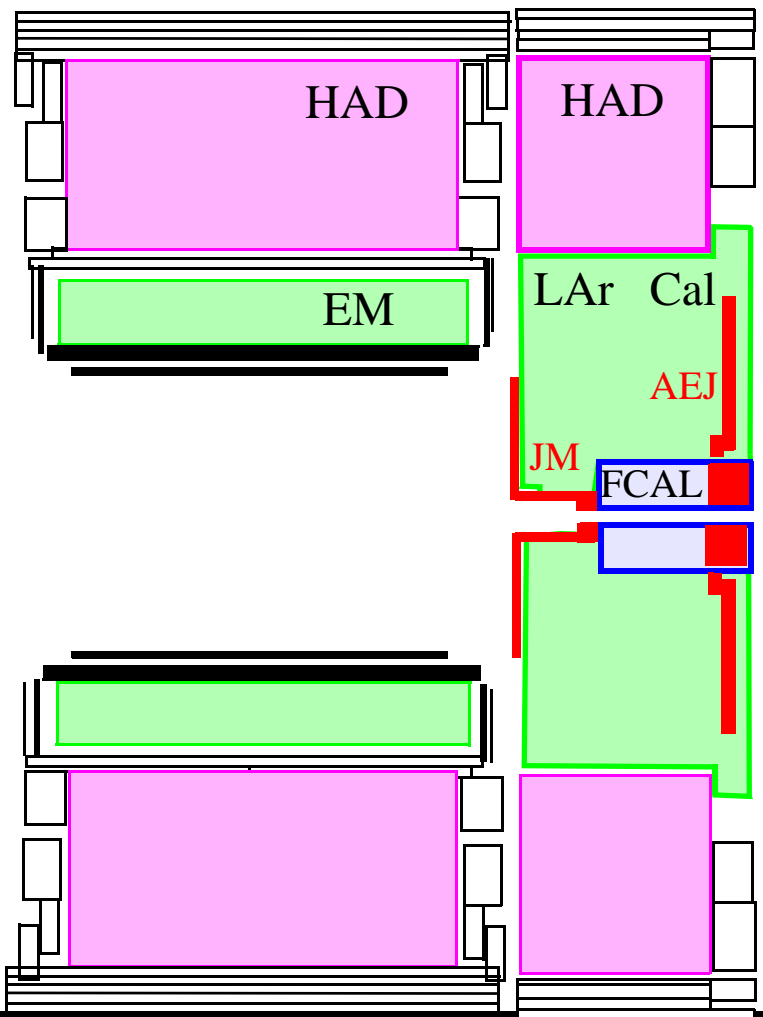

Rails

ACCESS

June 2006

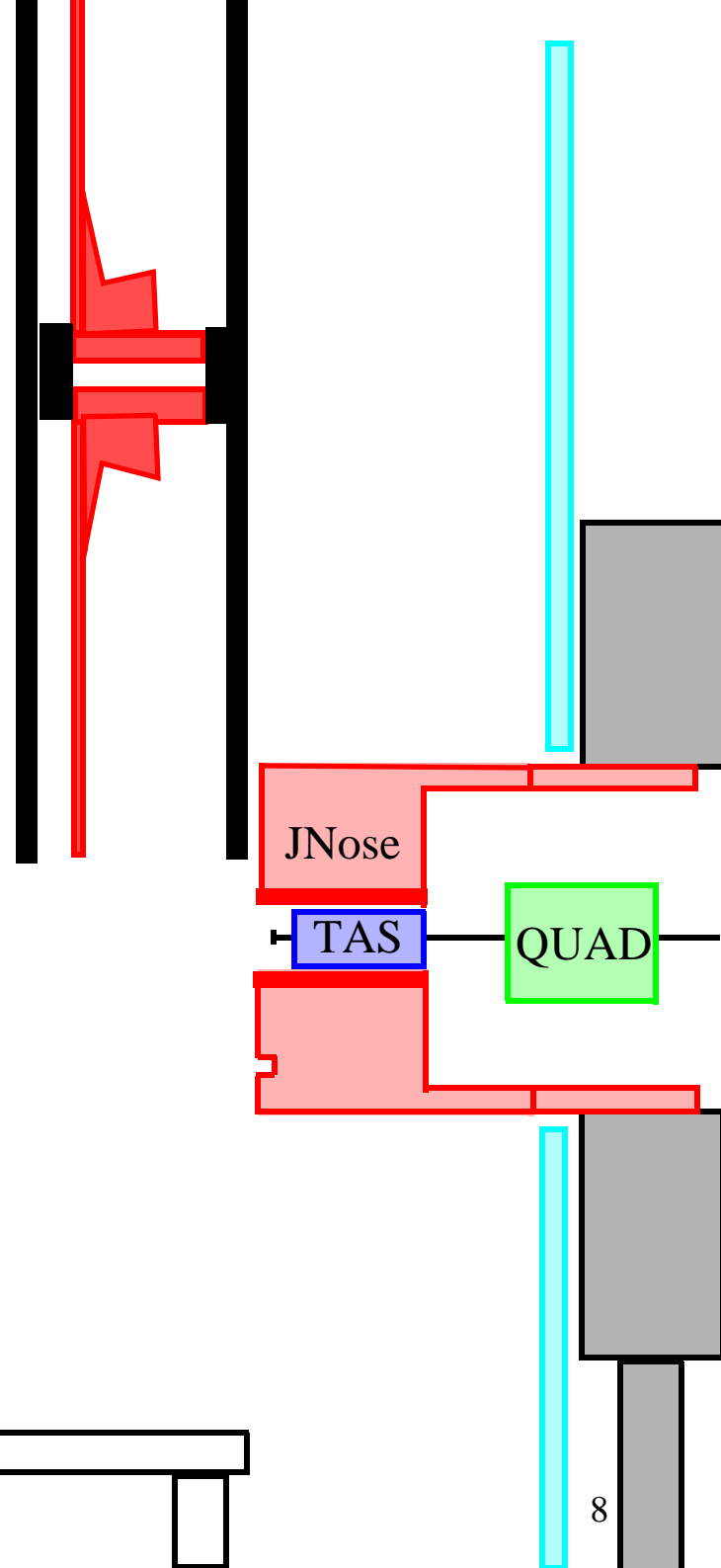
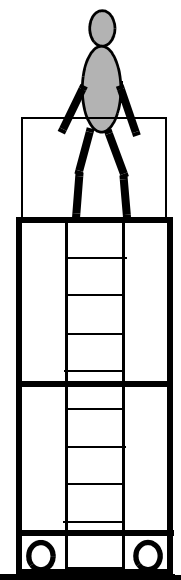
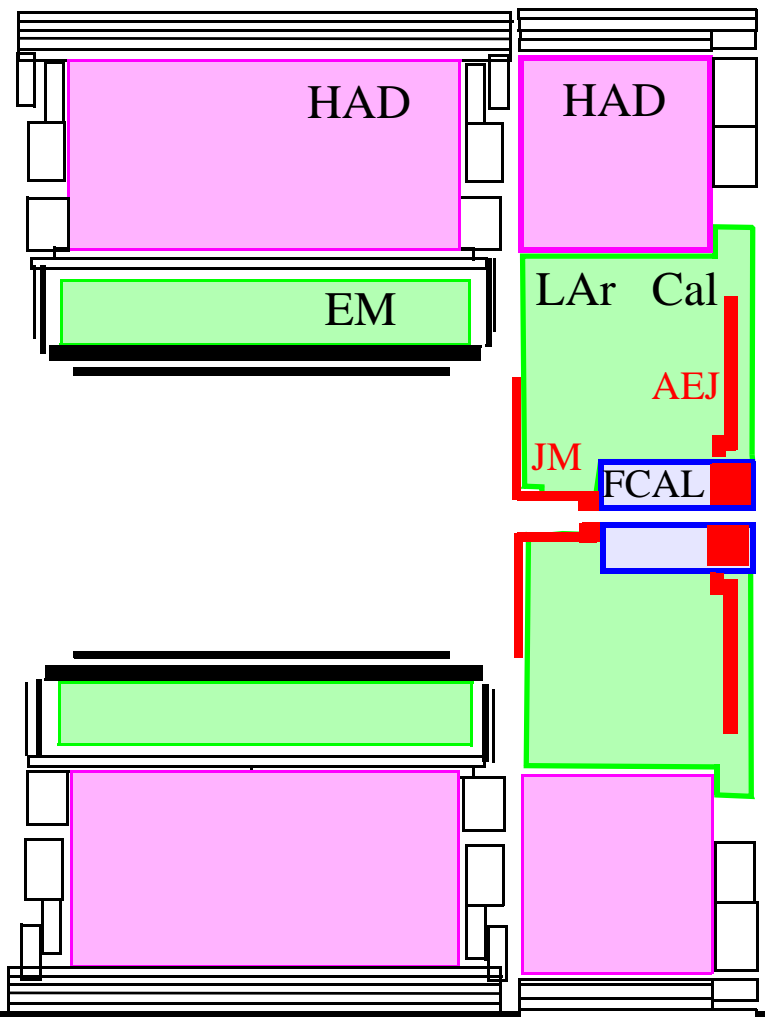

ACCESS

Rails

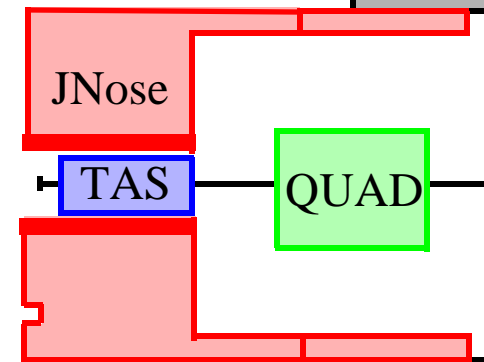
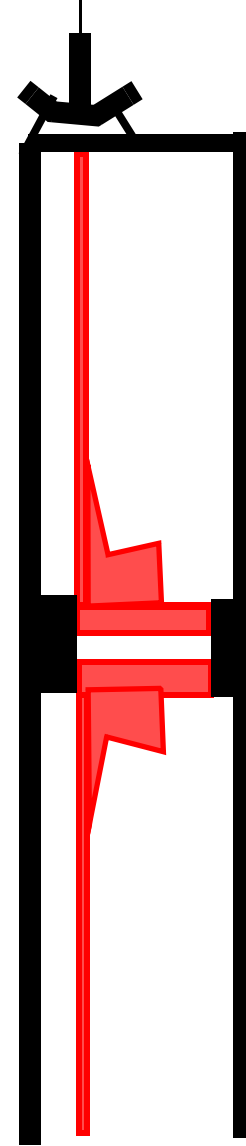
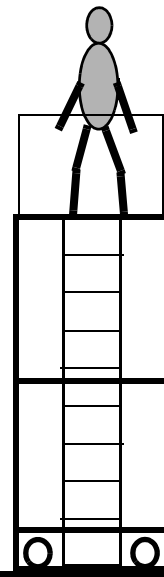
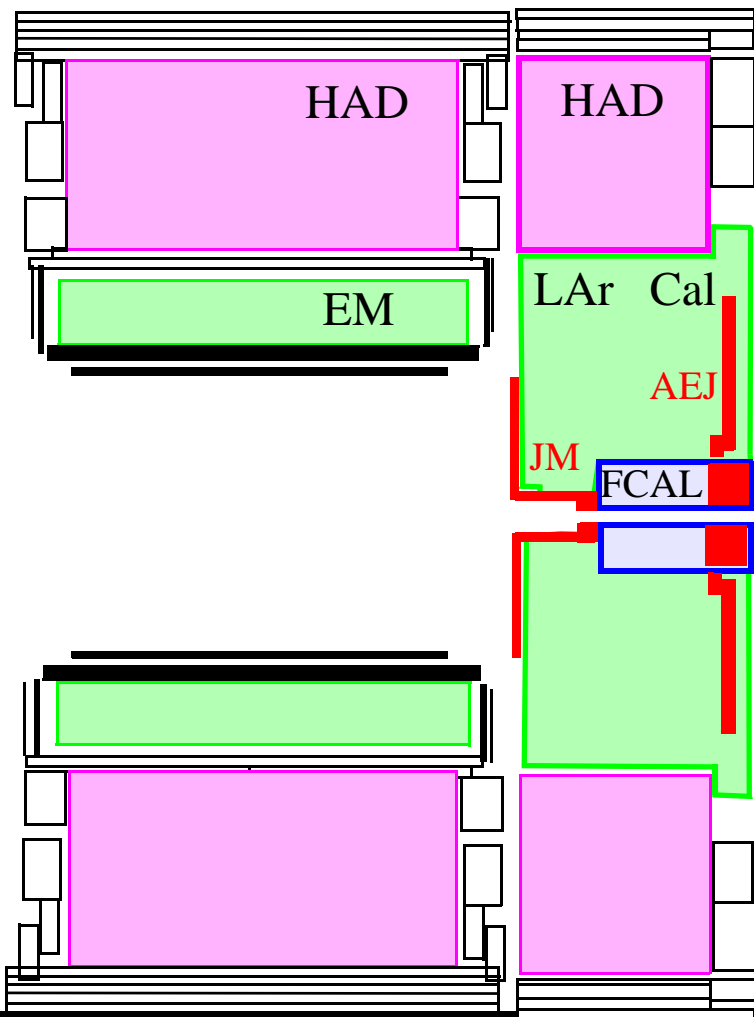

ACCESS

Rails

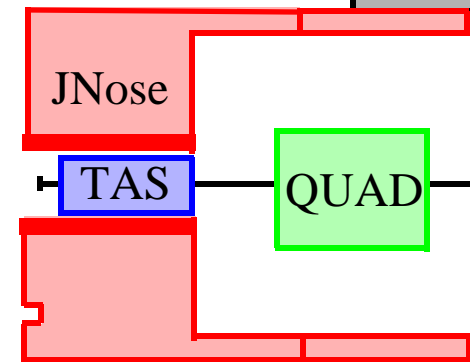
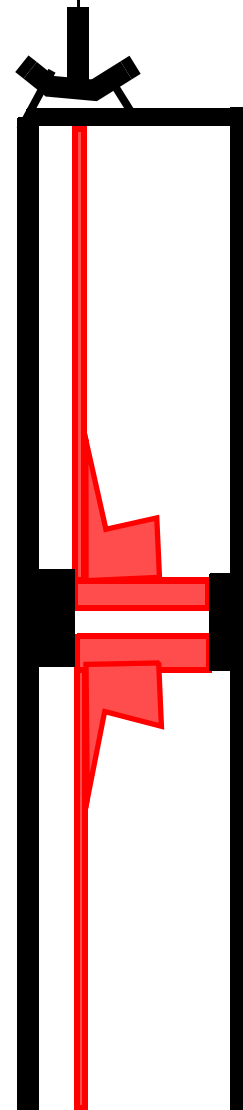
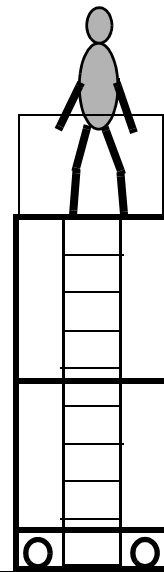
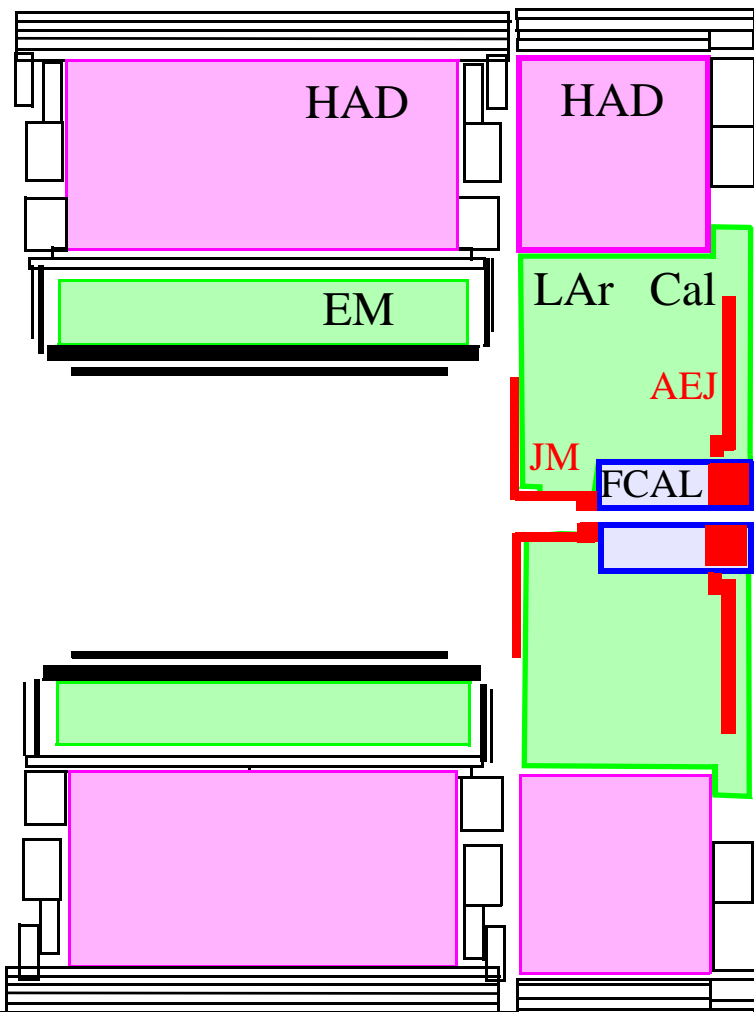

Rails

ACCESS

10

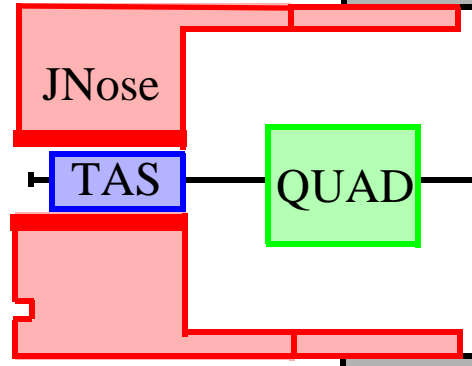
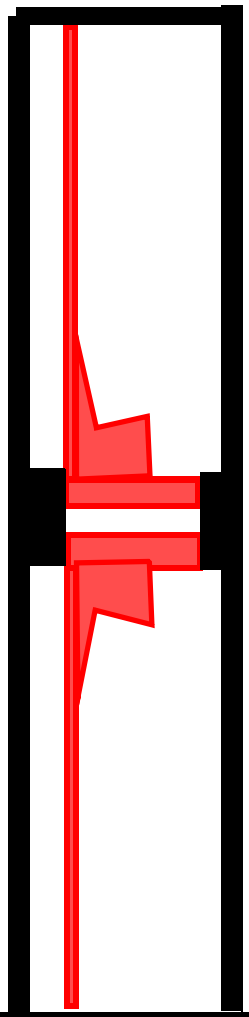
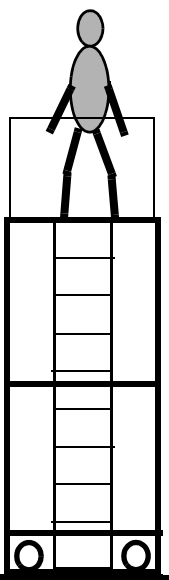
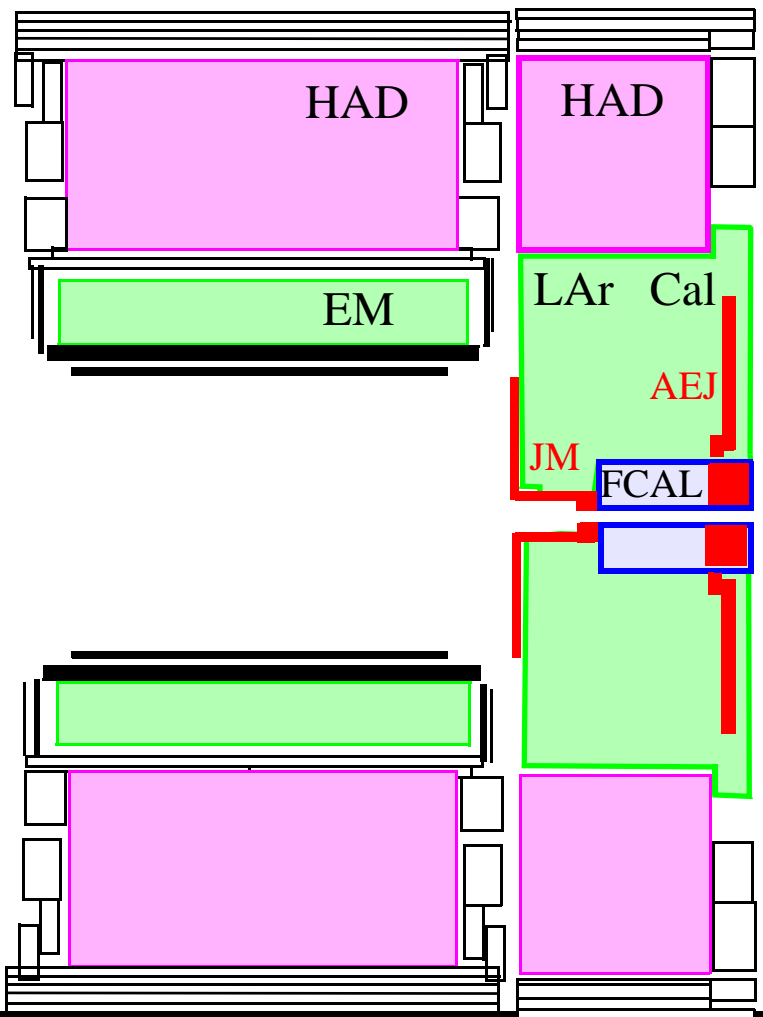

Rails

ACCESS

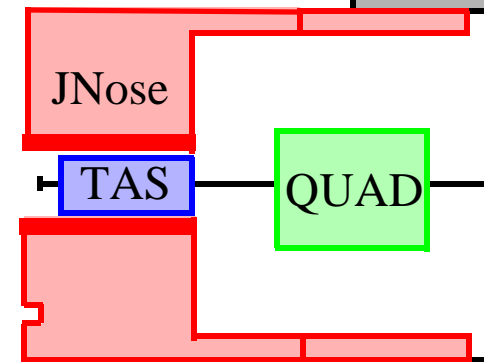
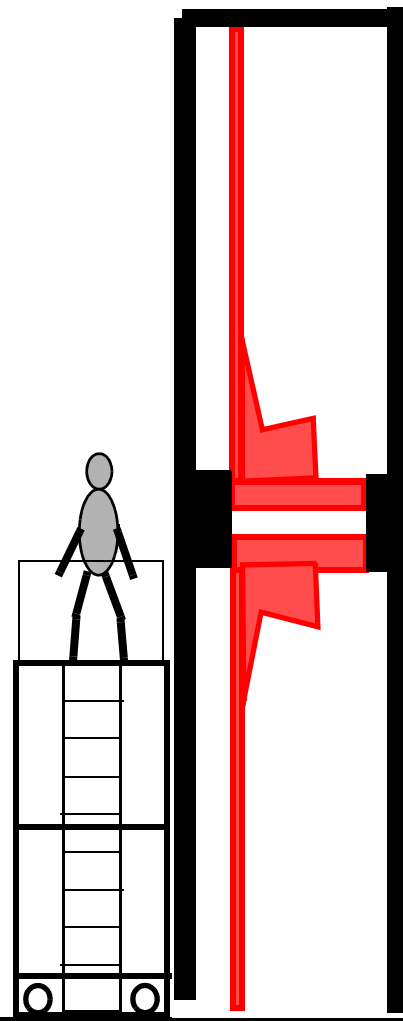
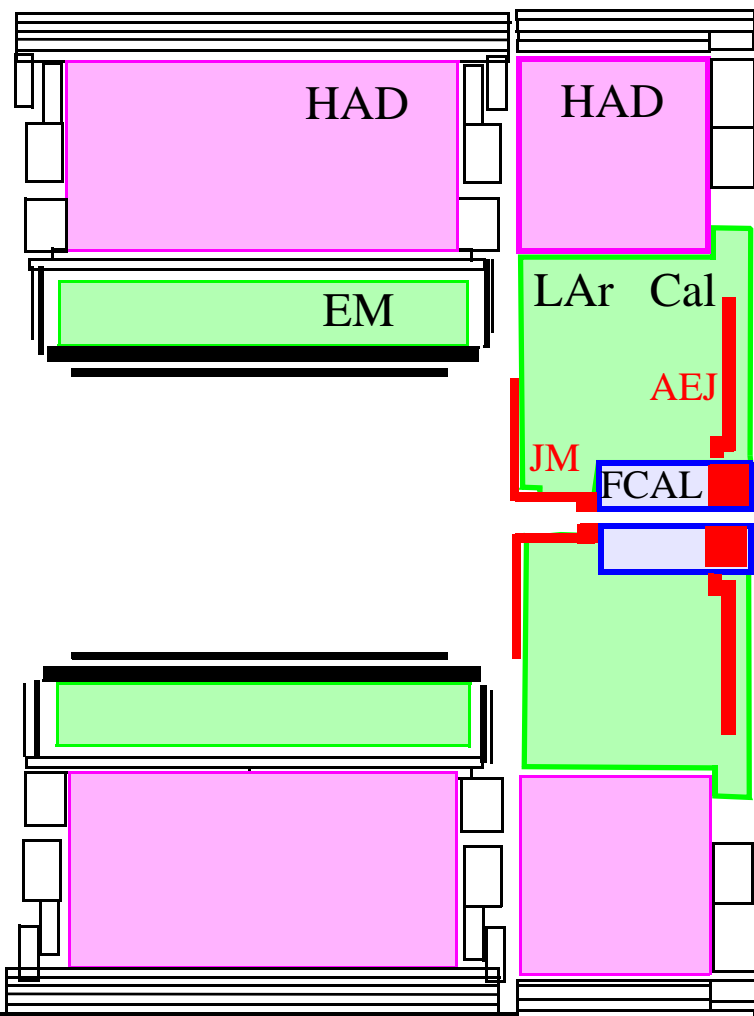

ACCESS

Rails

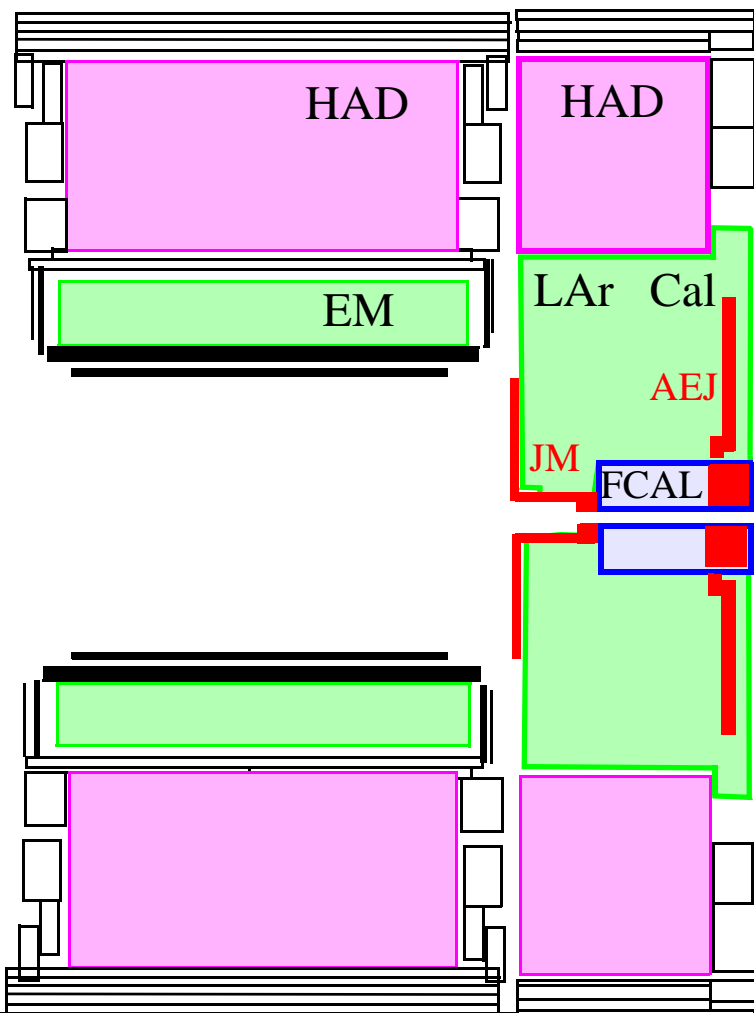

ACCESS

Rails

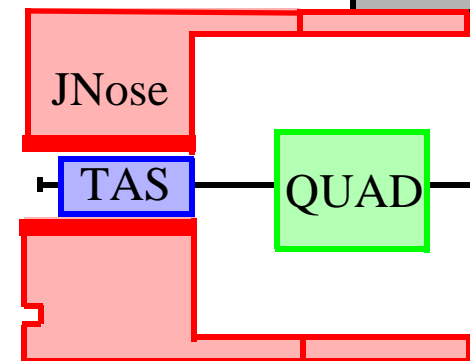
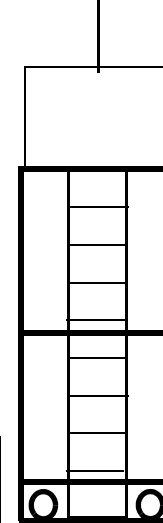
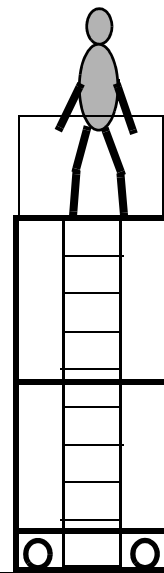

13

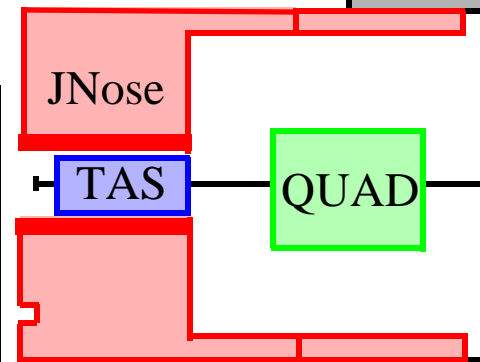
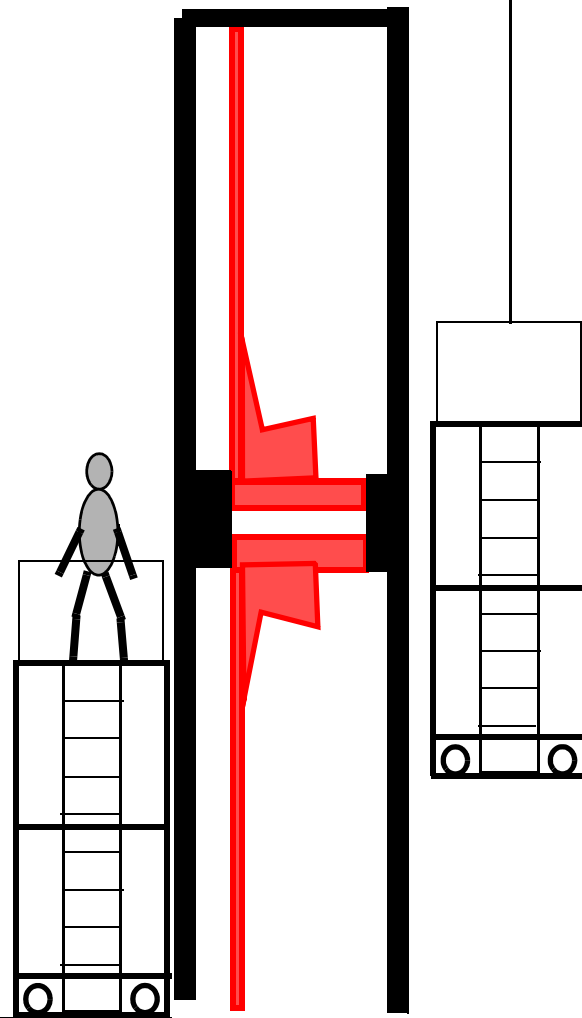
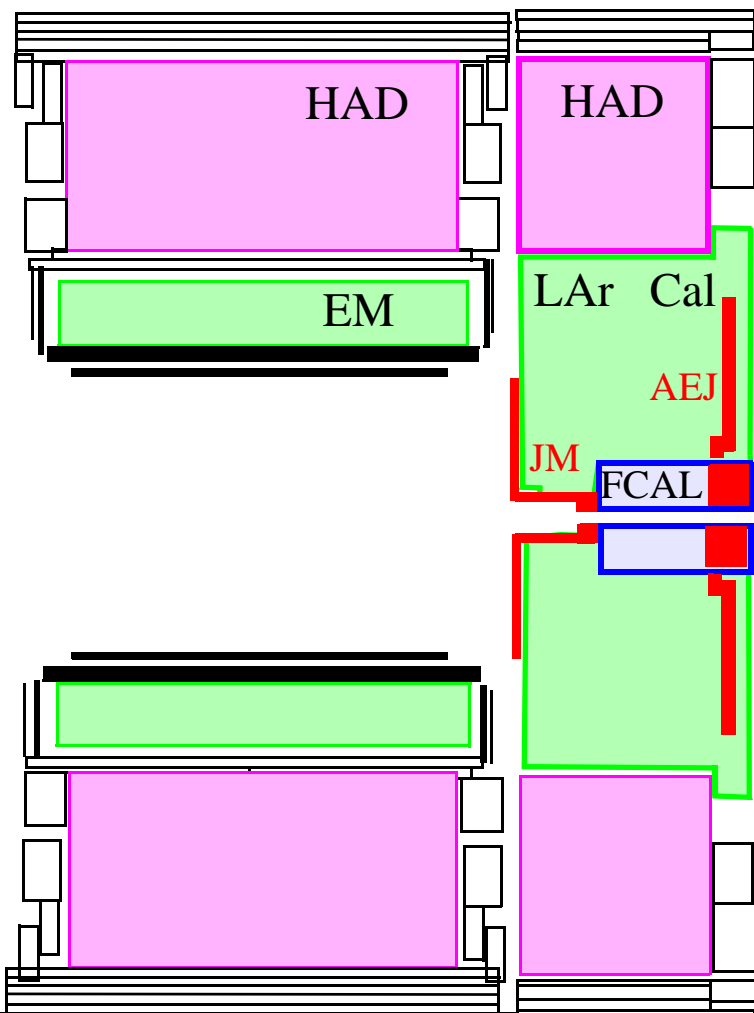

ACCESS

Rails

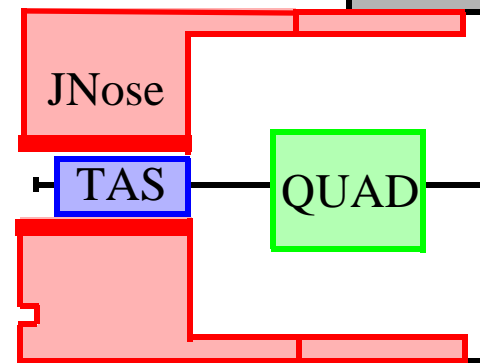
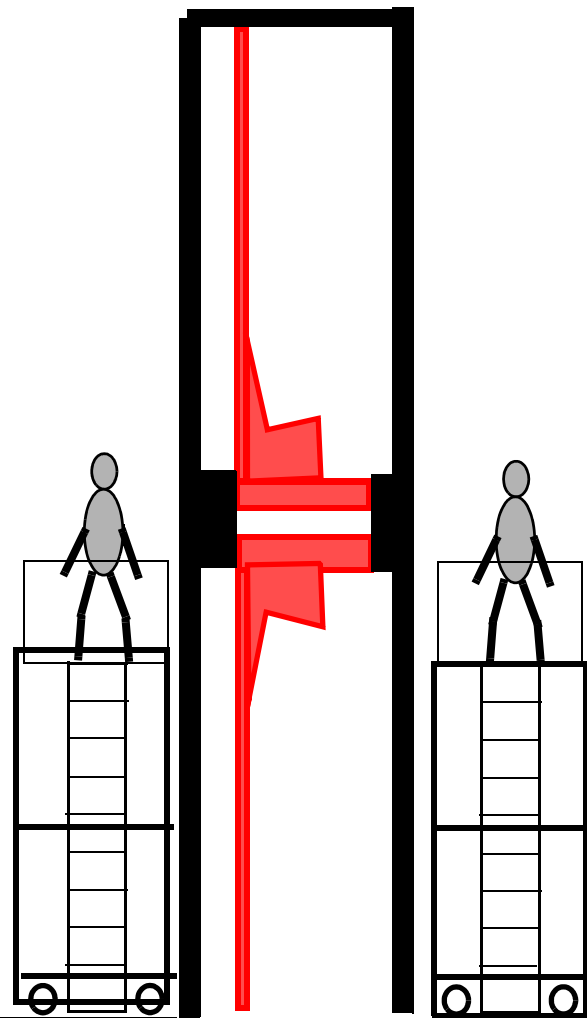
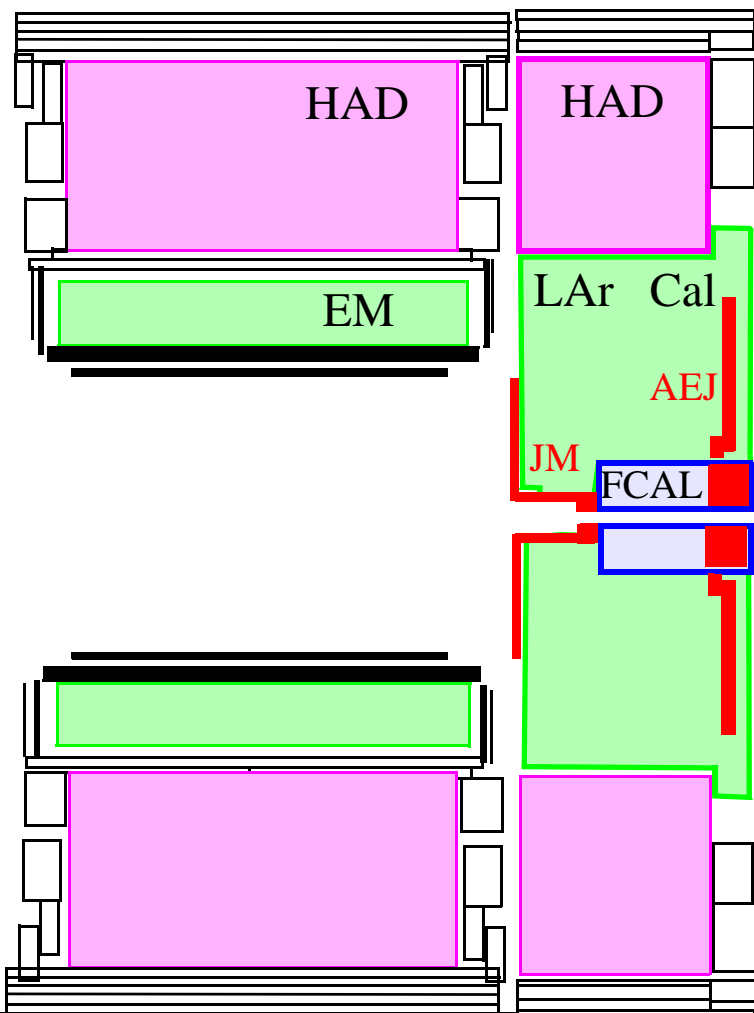

Rails

ACCESS

15

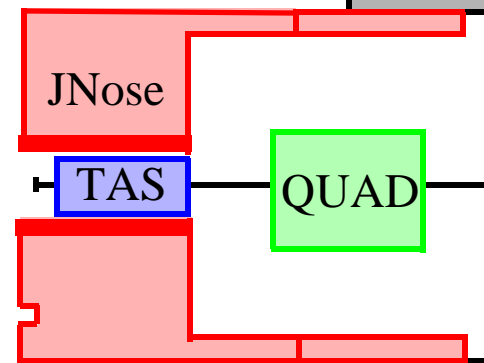
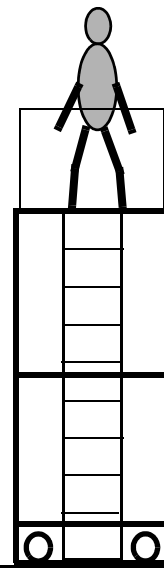
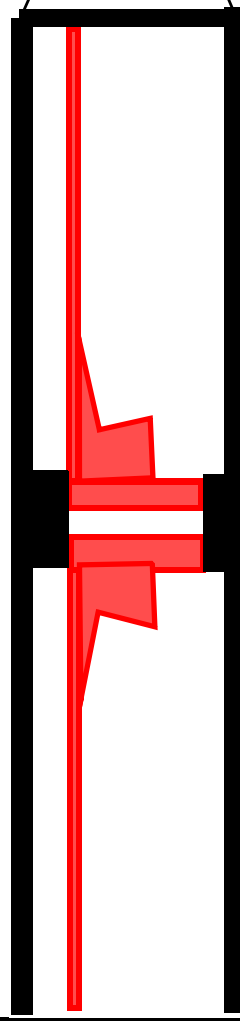
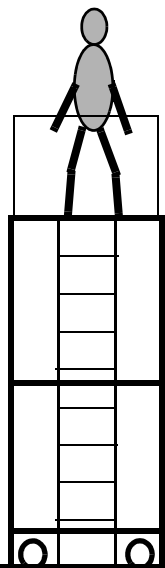
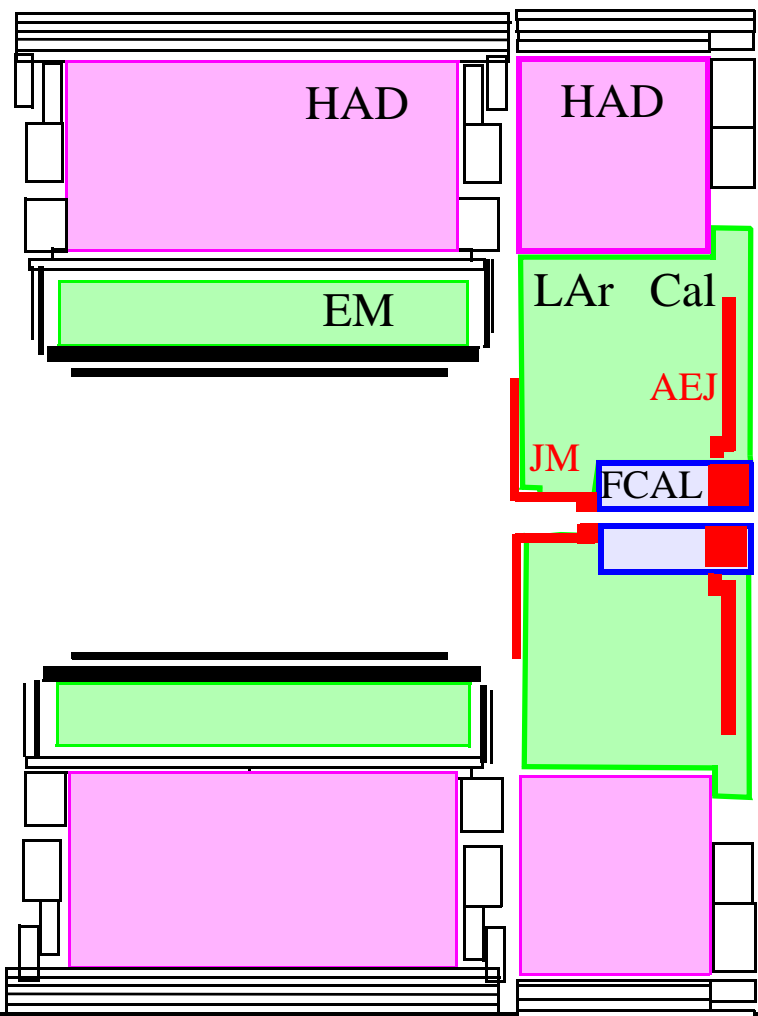

Rails

ACCESS

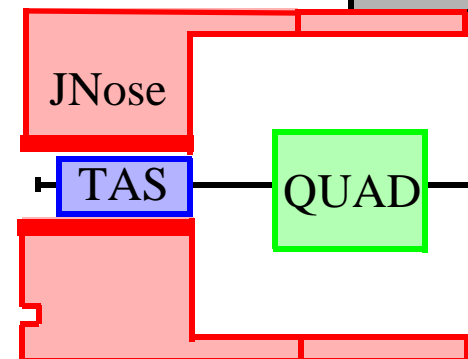
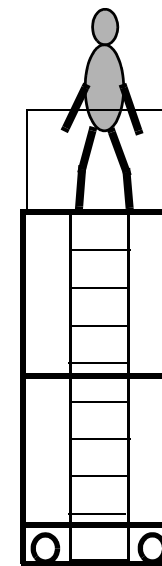
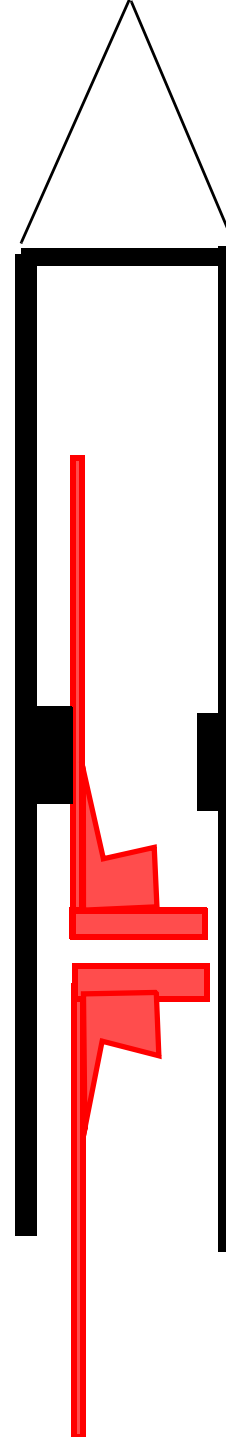
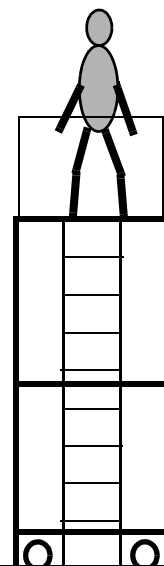
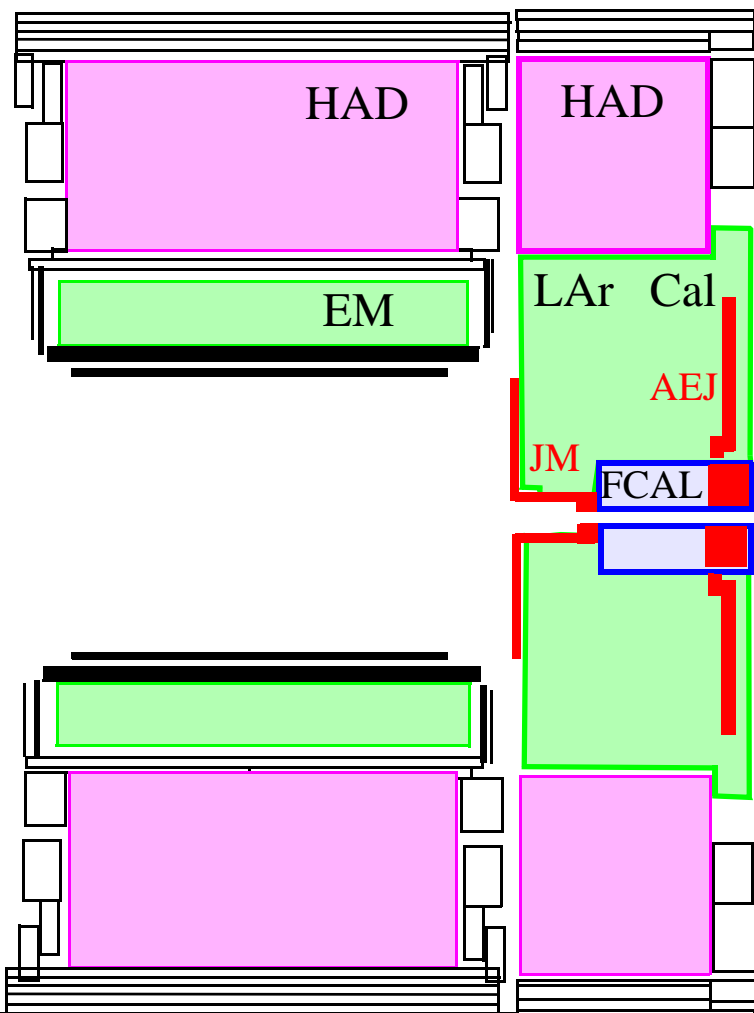

Rails

ACCESS

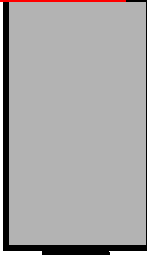
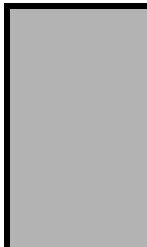
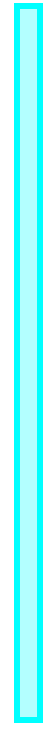
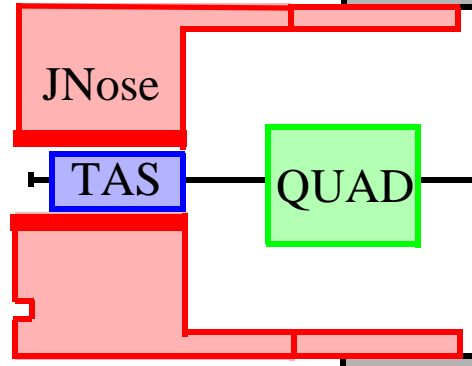
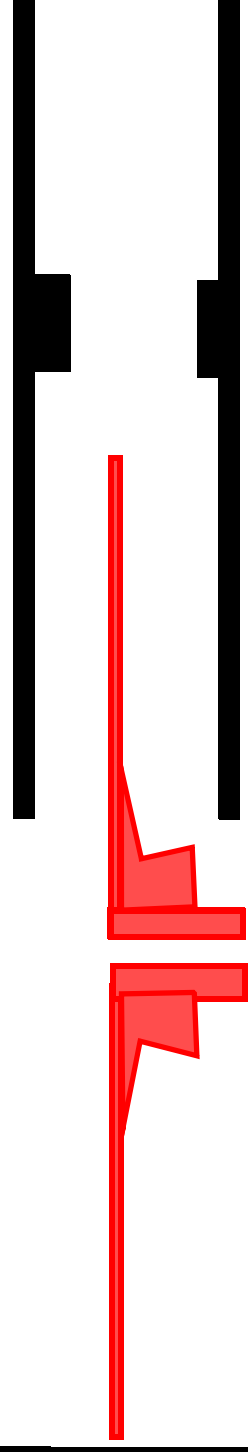
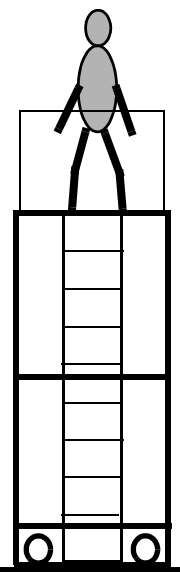
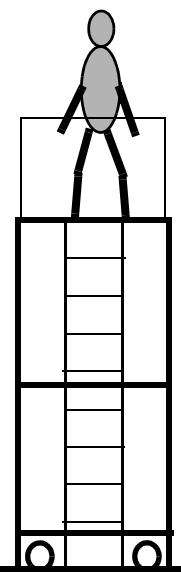
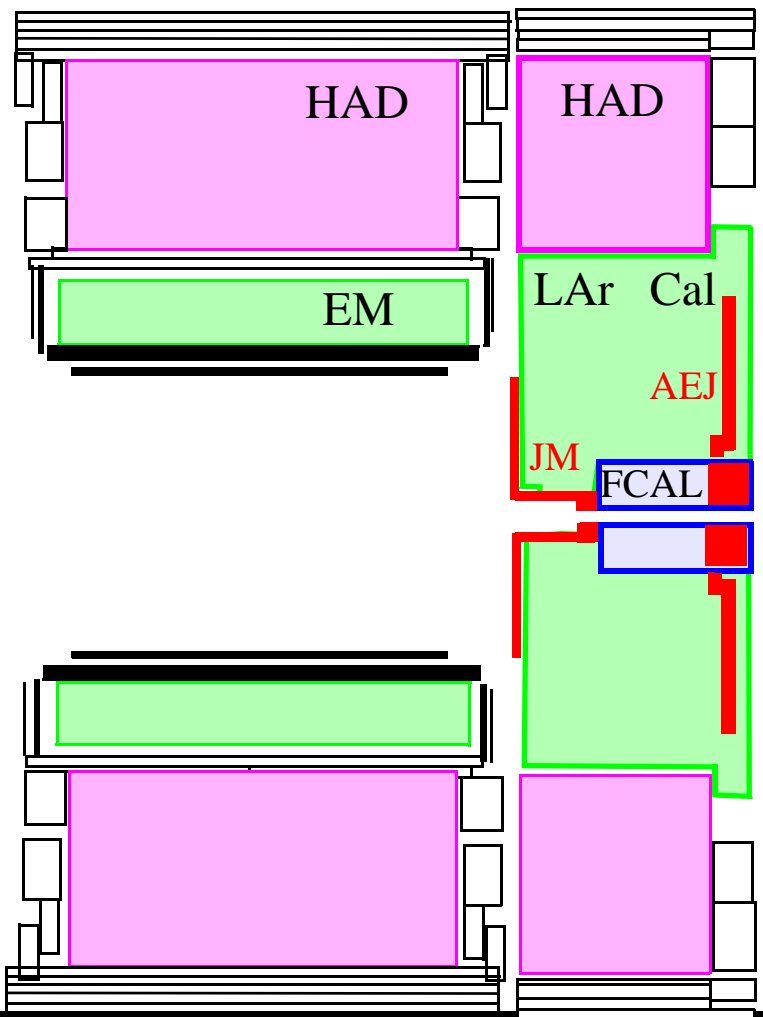

Rails

ACCESS

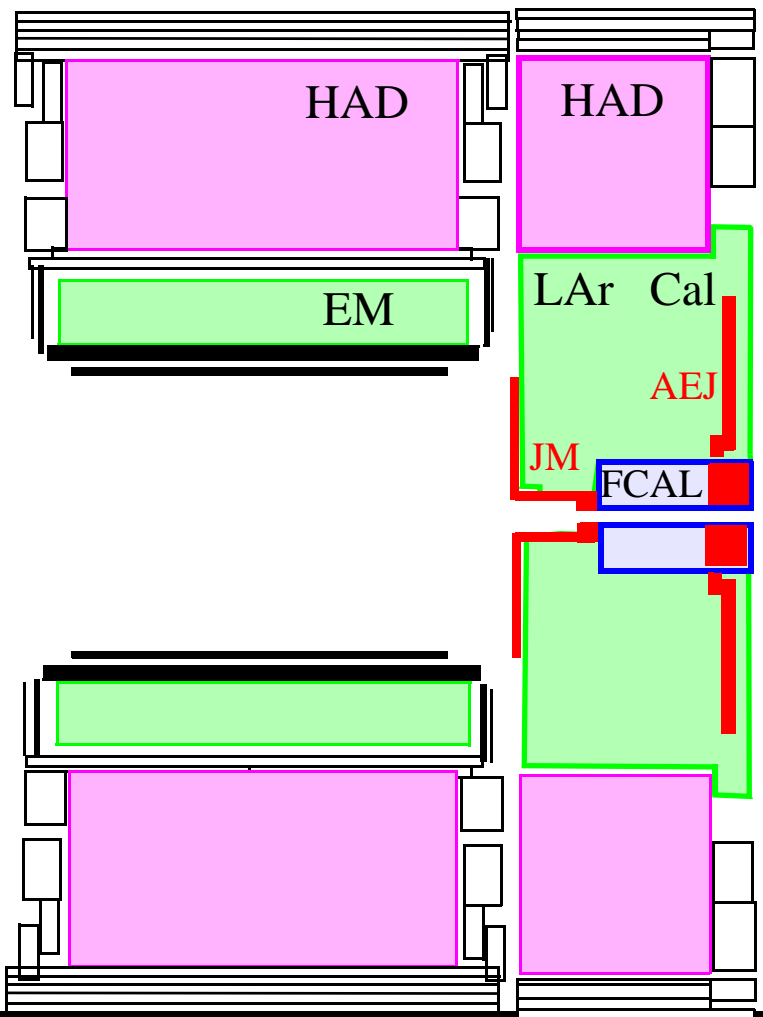

AEJ
 JM

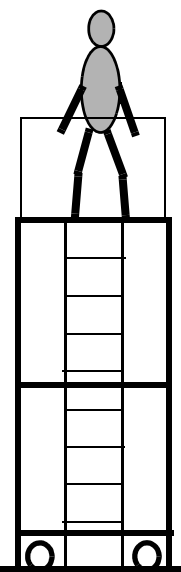

Rails

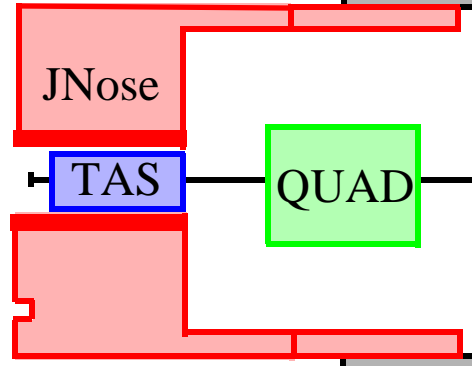
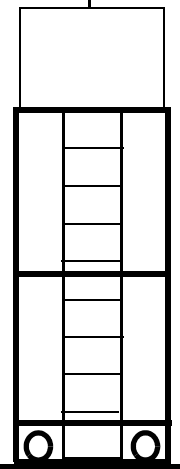
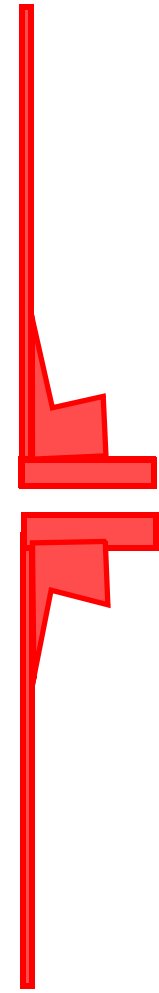

ACCESS



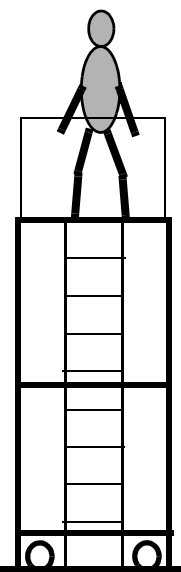
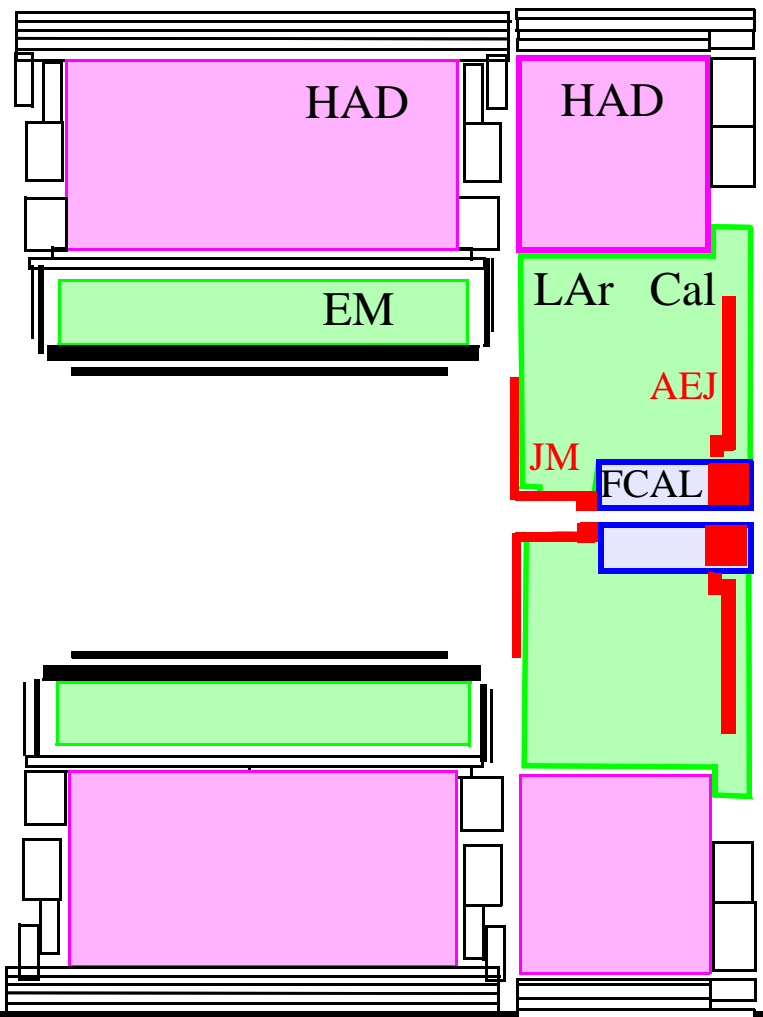

Rails

ACCESS

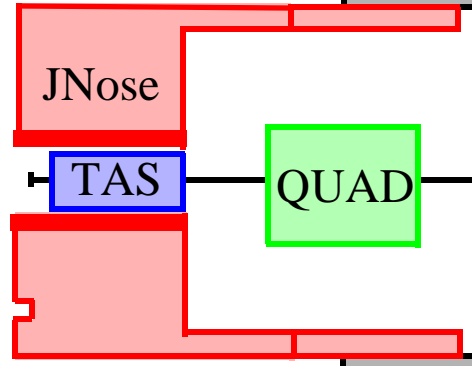
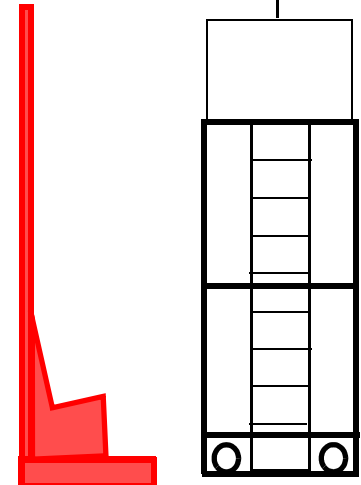

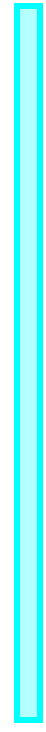
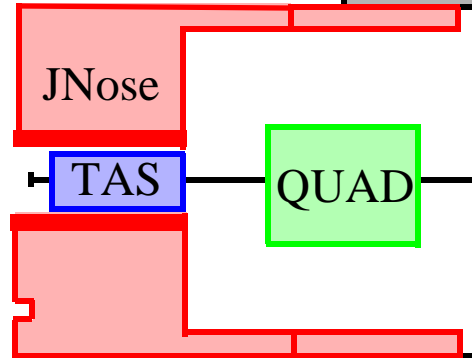
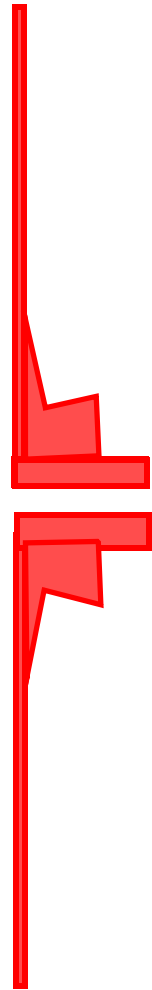
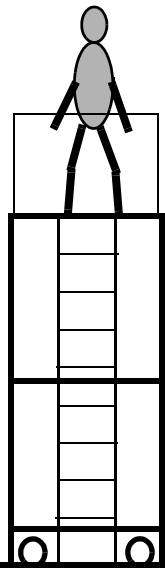
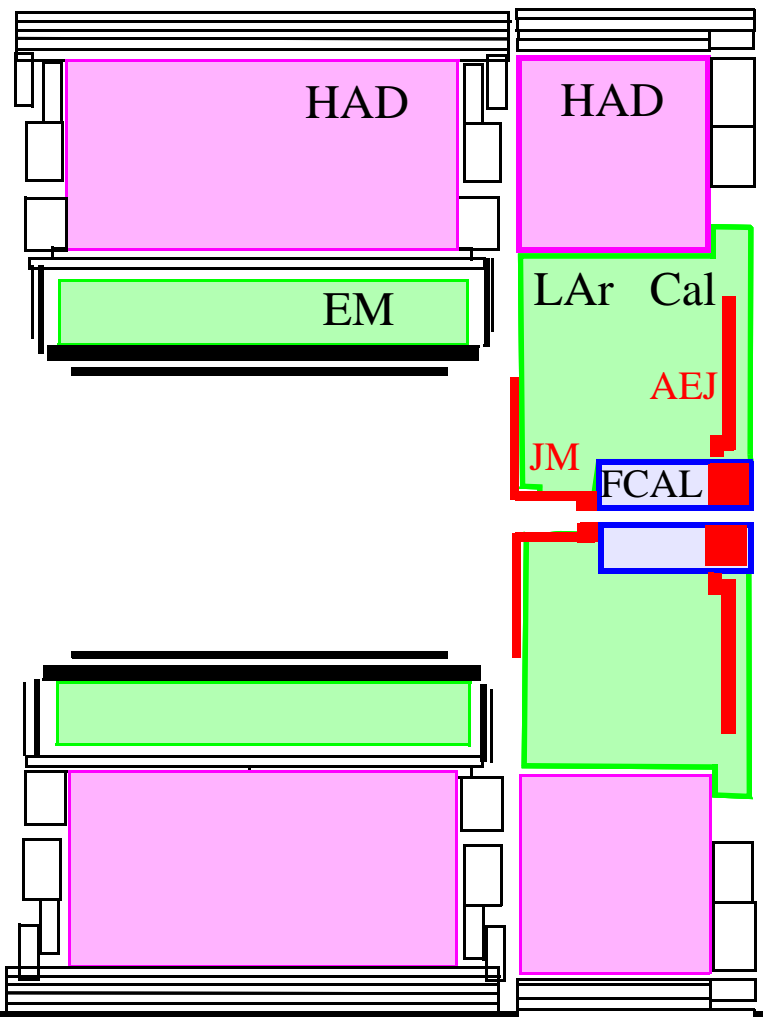

ACCESS

Rails

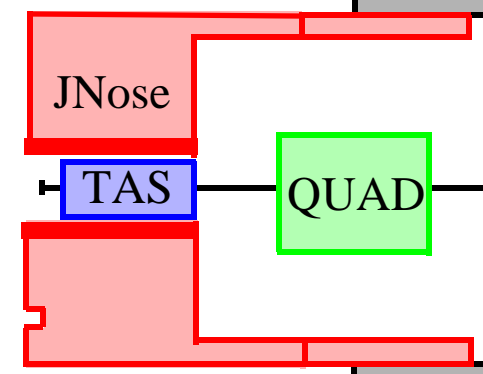
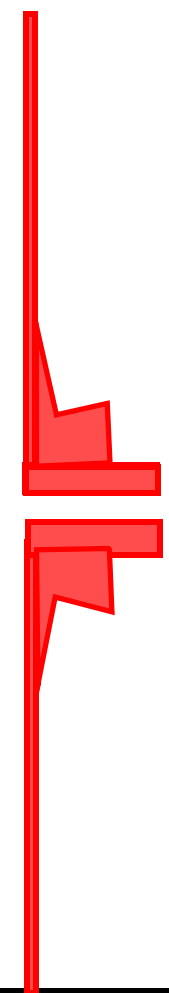
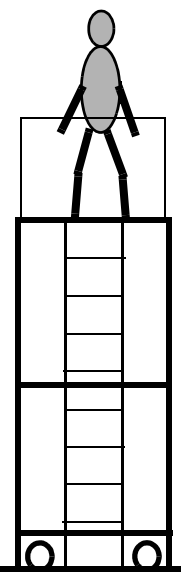
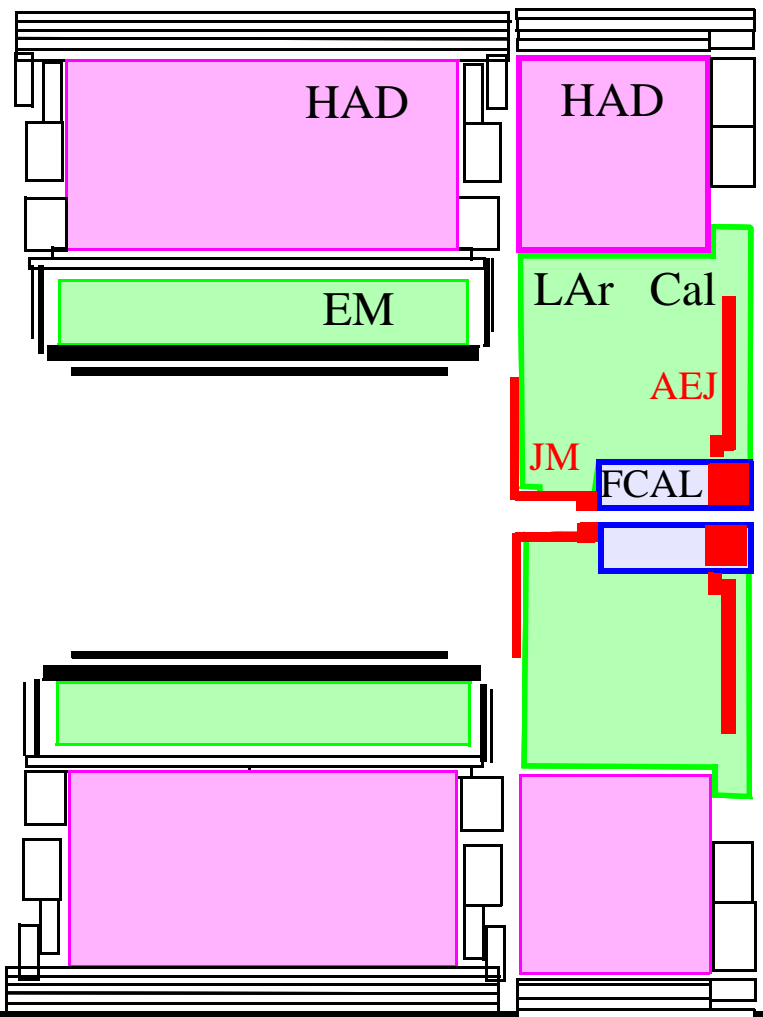

ACCESS

Rails

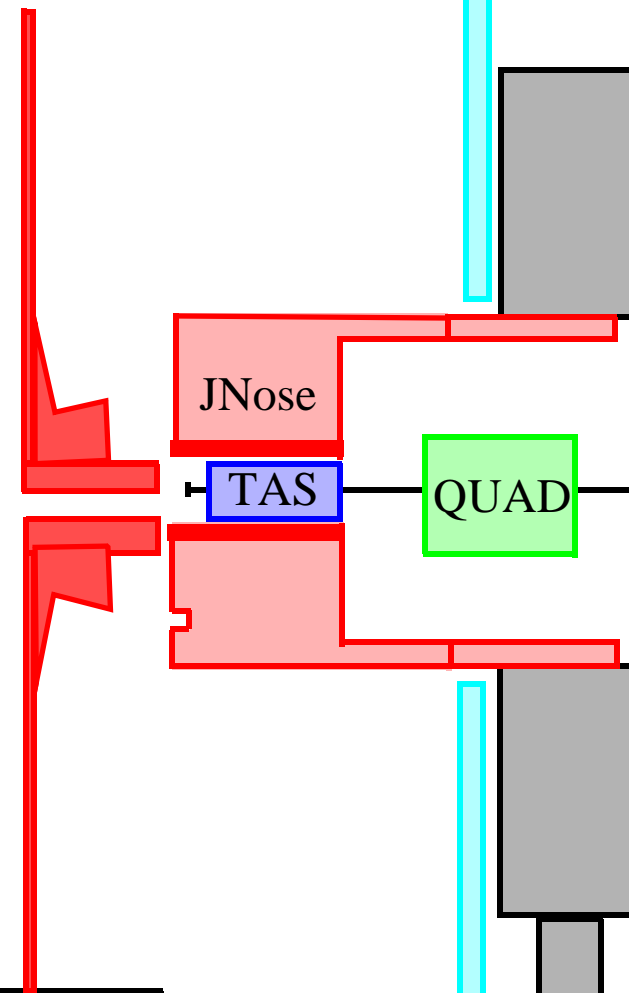
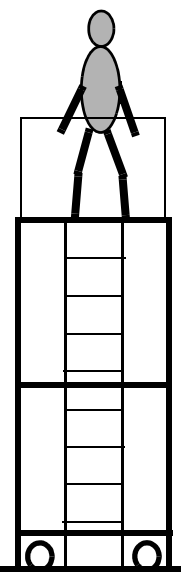
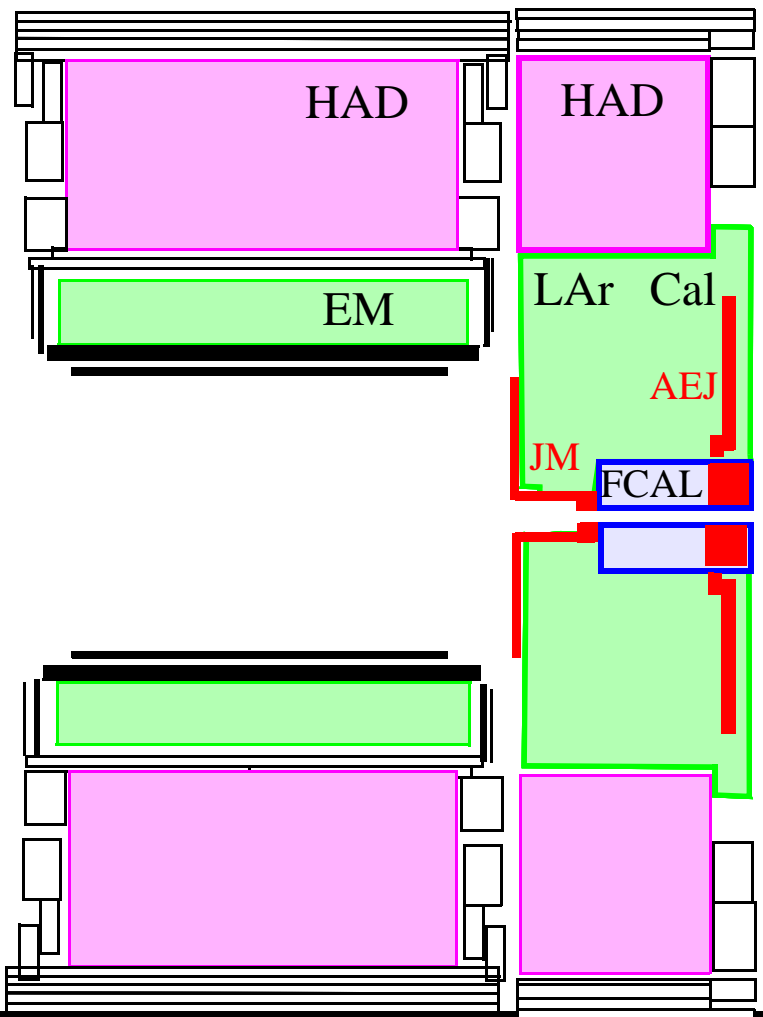

ACCESS

Rails

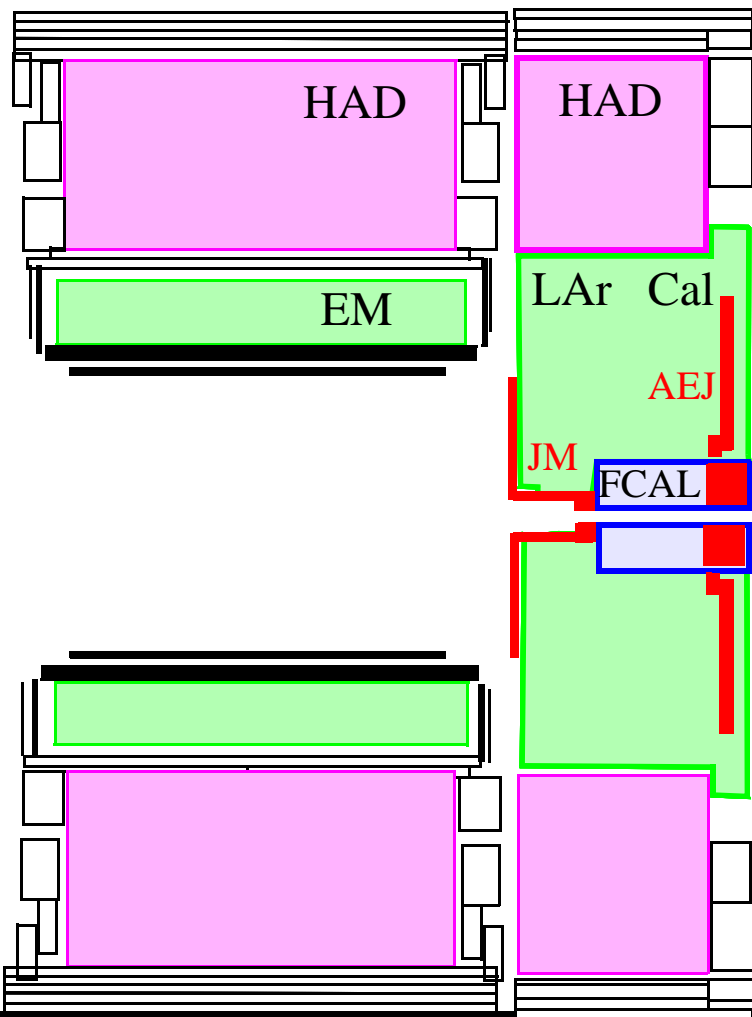

ACCESS

Rails

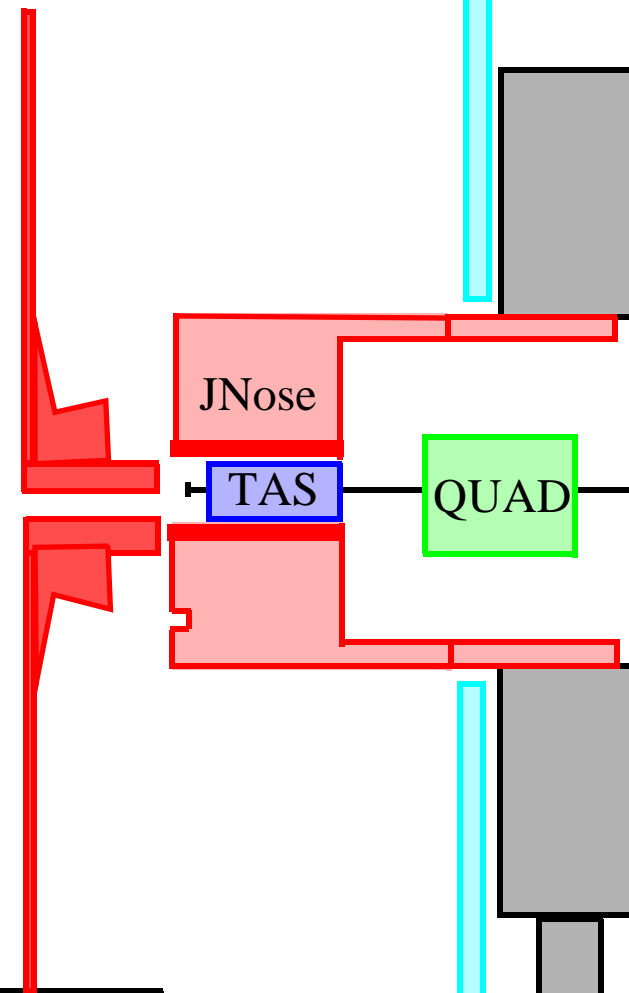
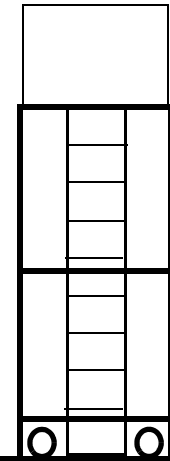

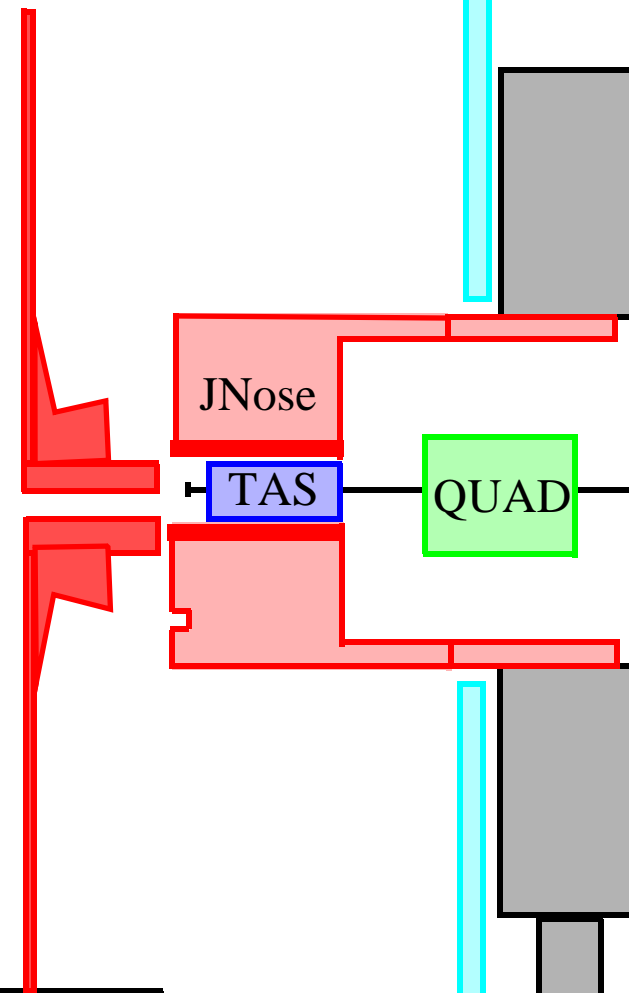
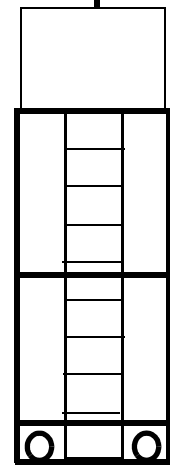
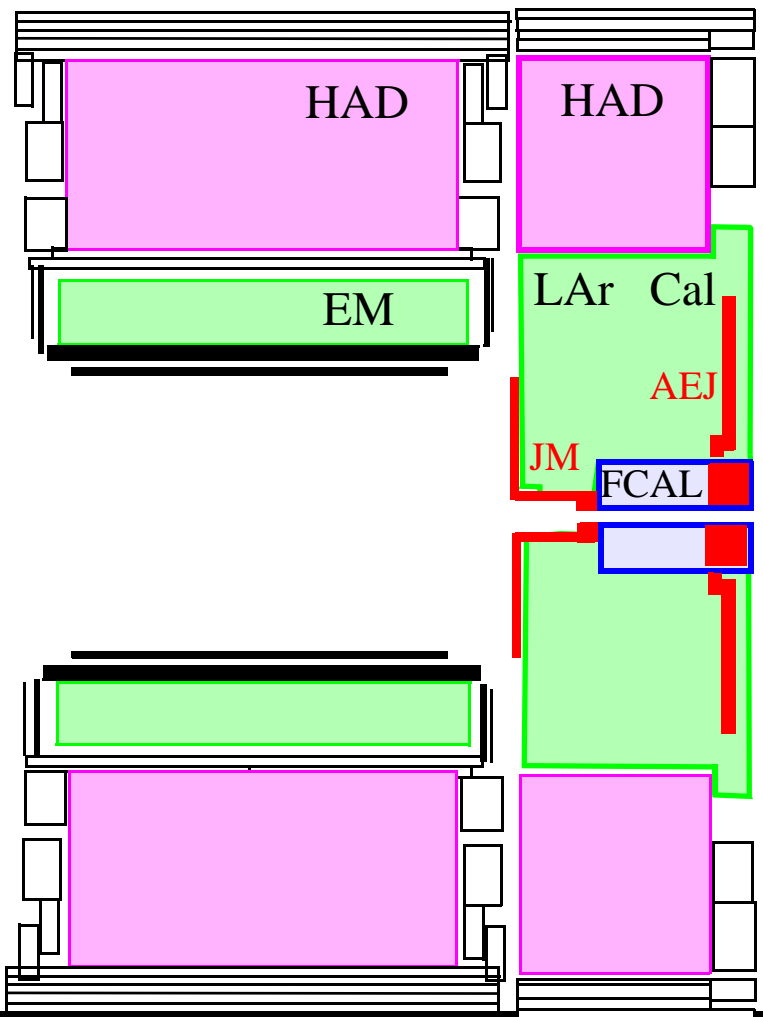

ACCESS

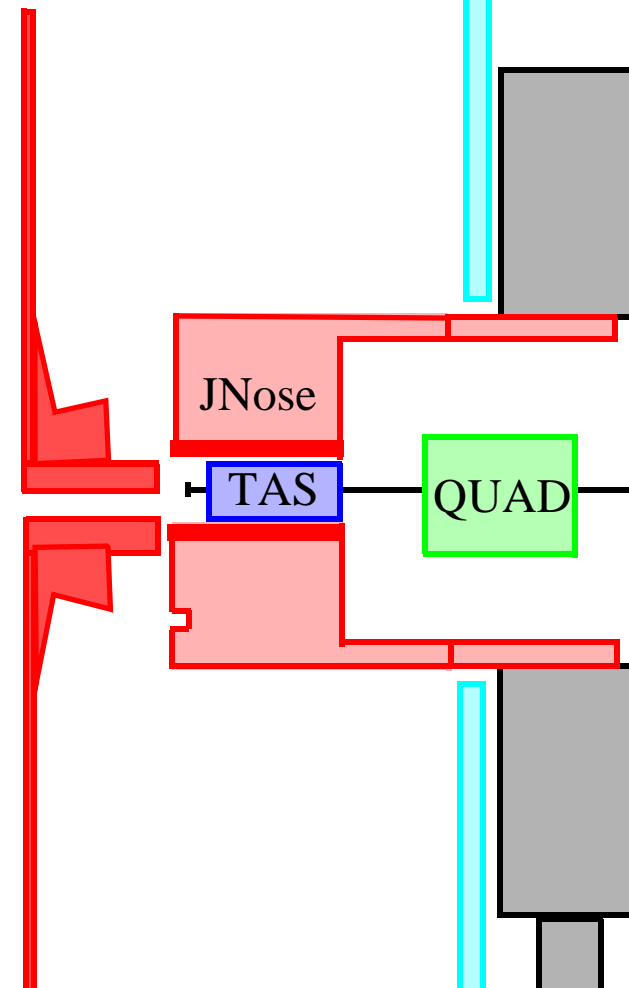
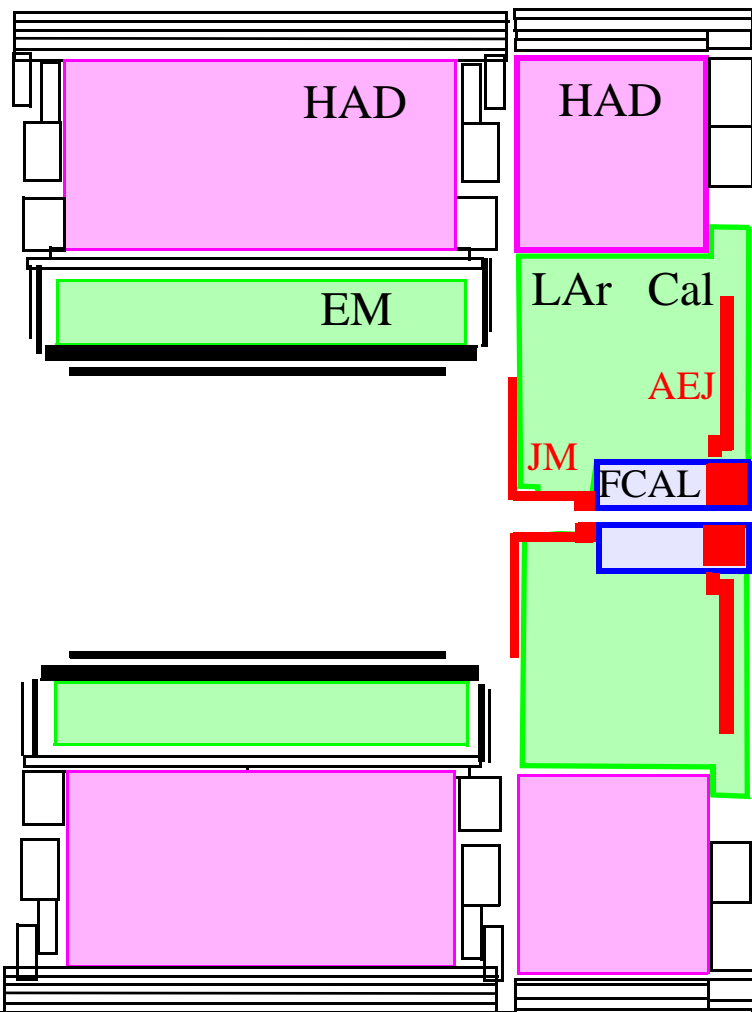

Rails

ACCESS

26

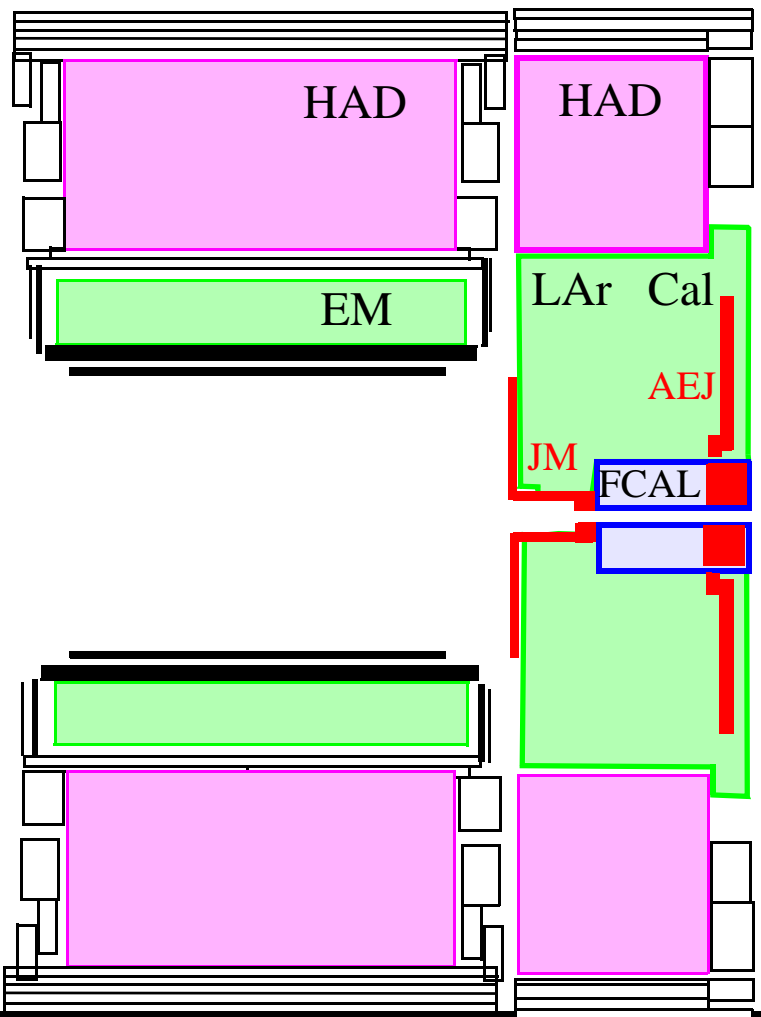

ACCESS

Rails

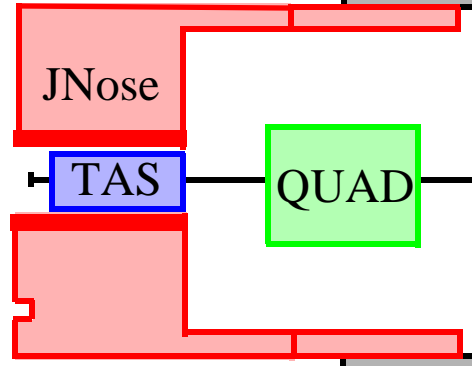
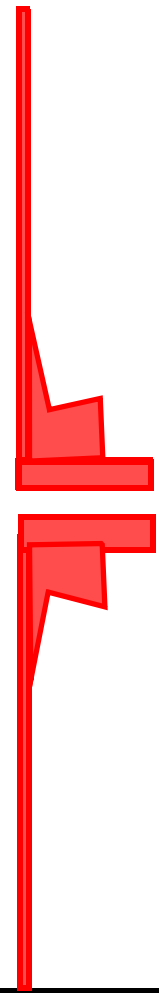

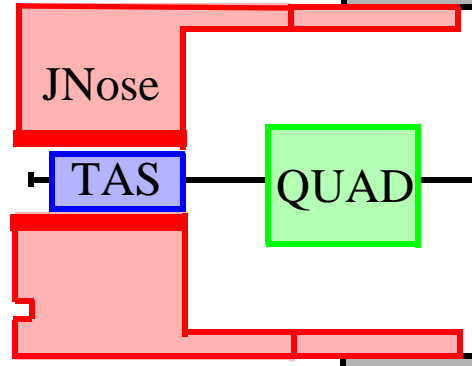
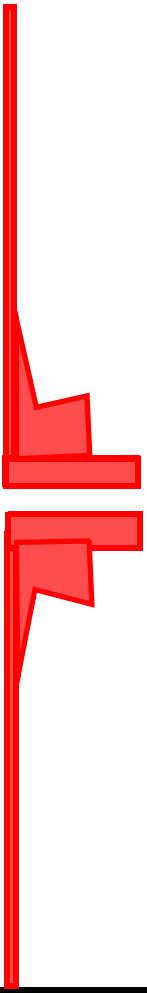
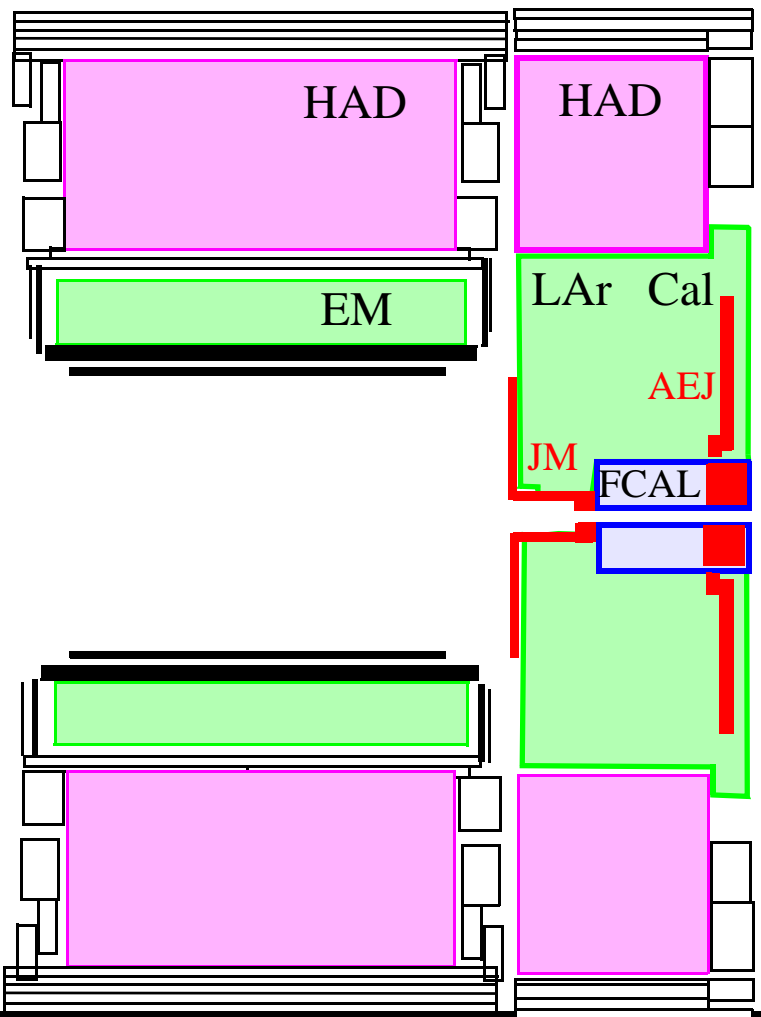

Rails

ACCESS

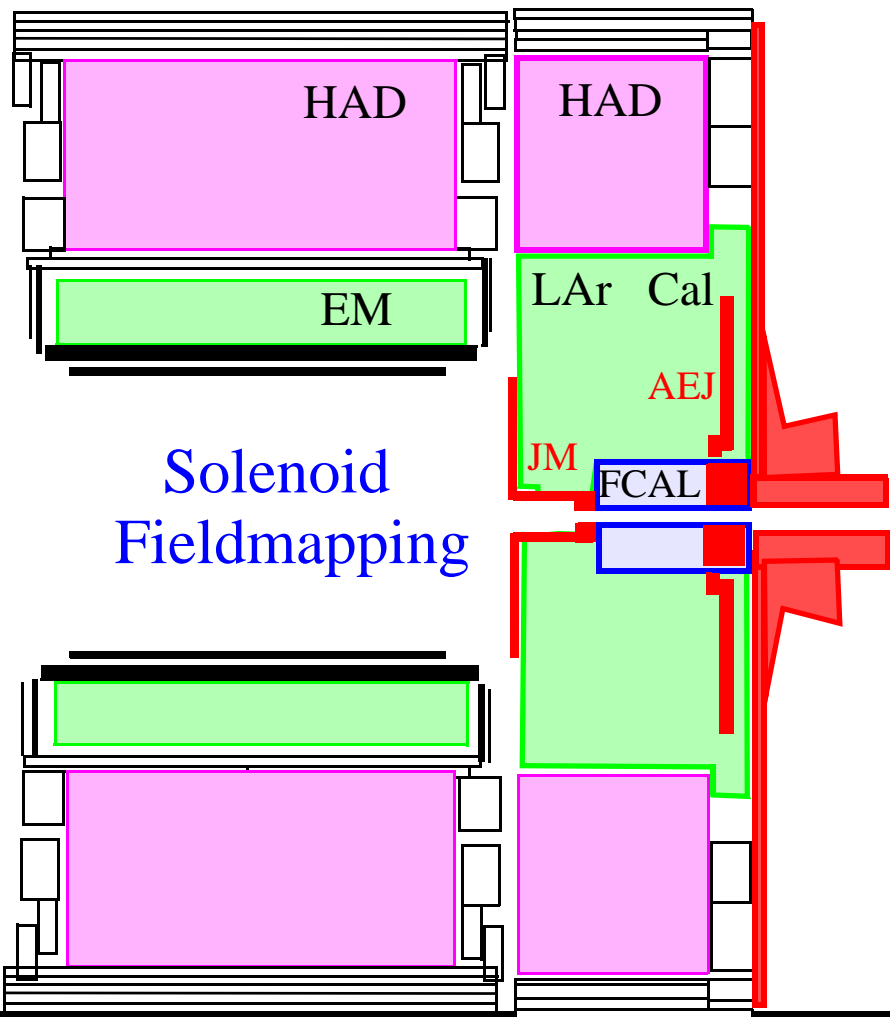

Solenoid
Fieldmapping

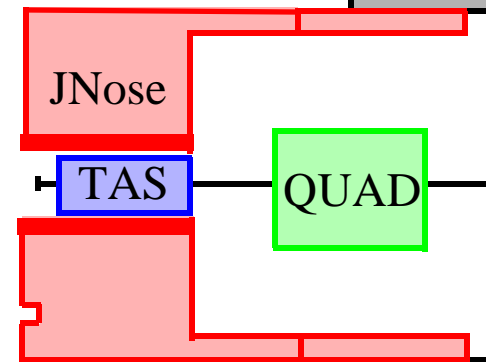

ACCESS

Rails

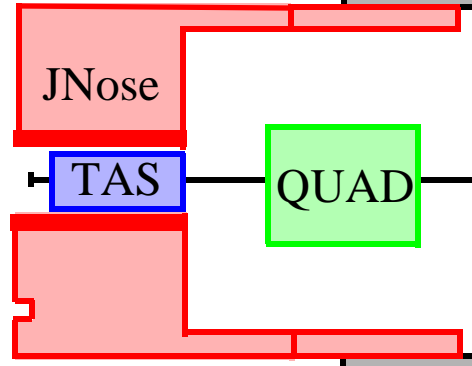
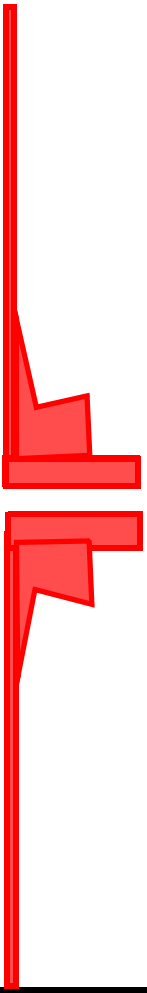
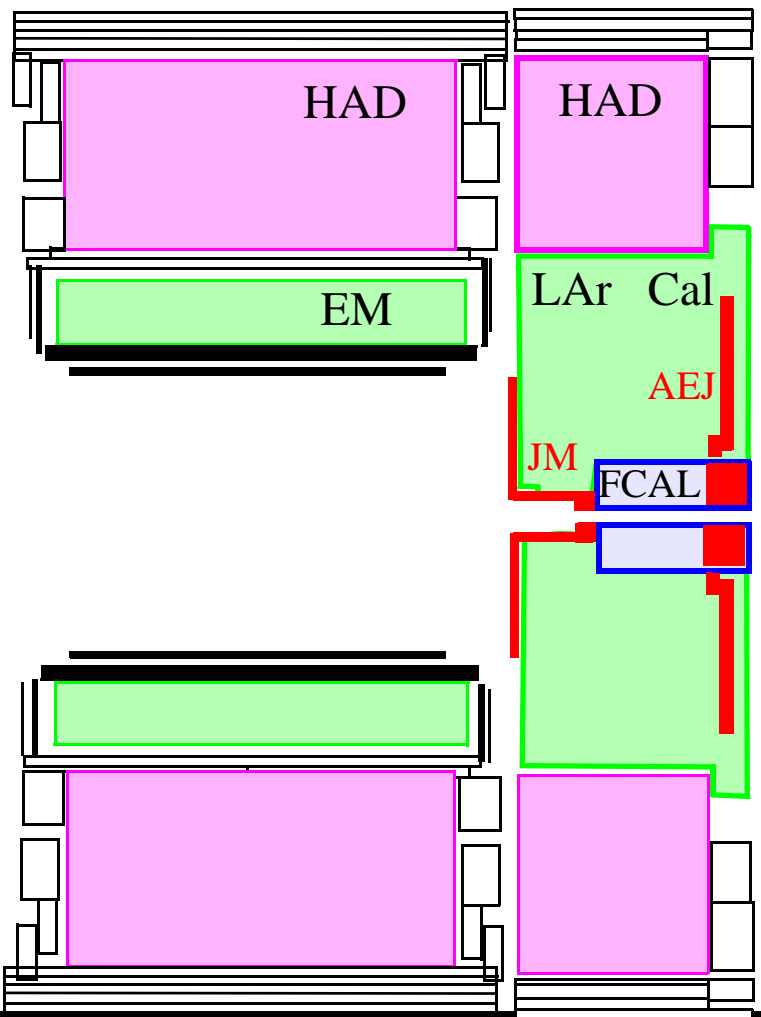

ACCESS

Rails

30

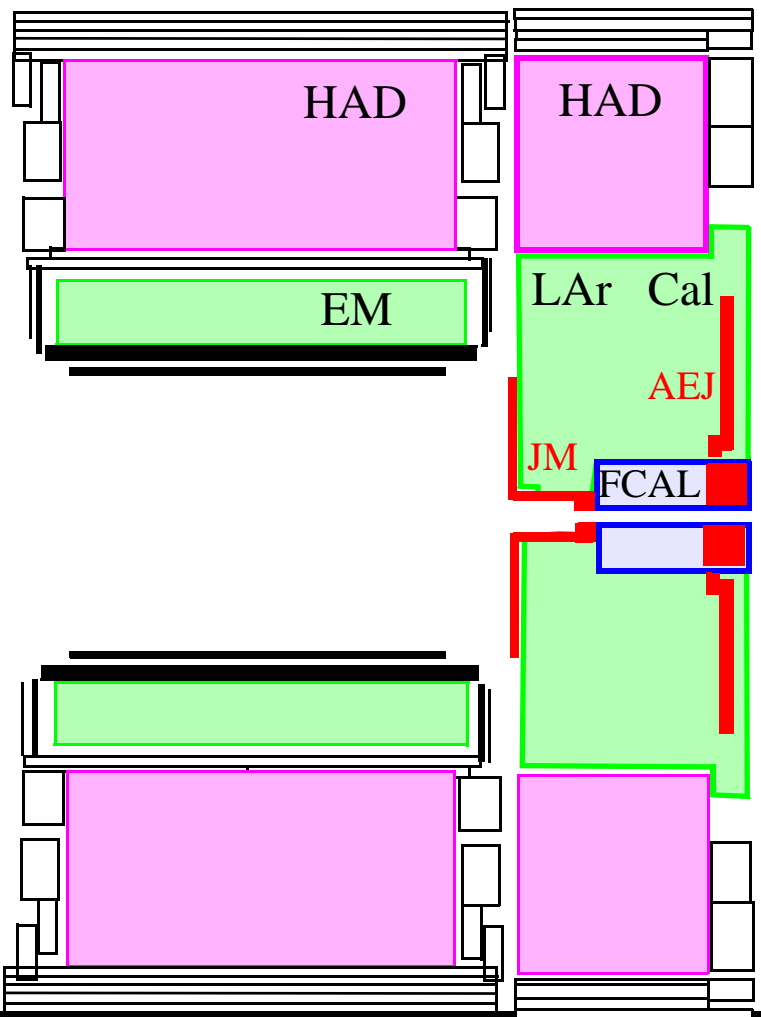

ACCESS

Rails

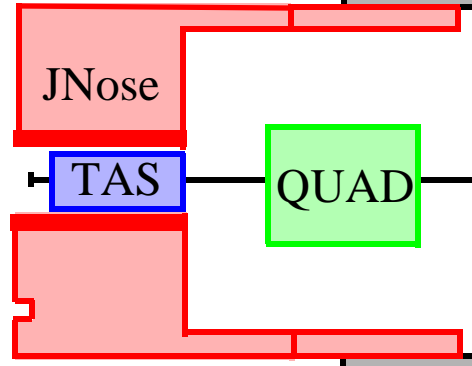
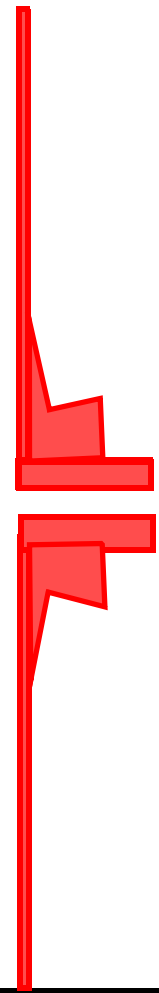

31

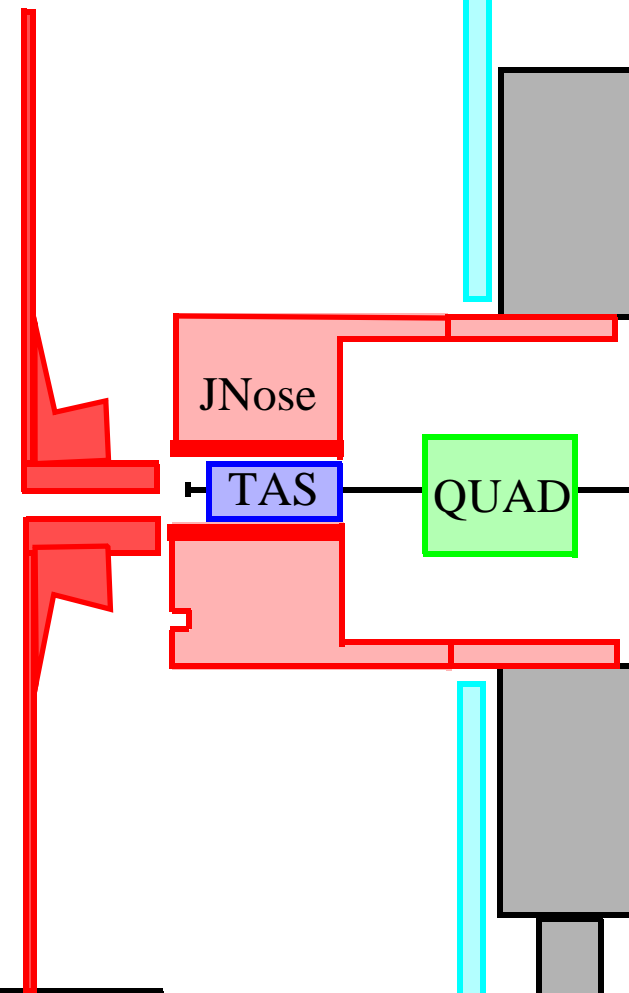
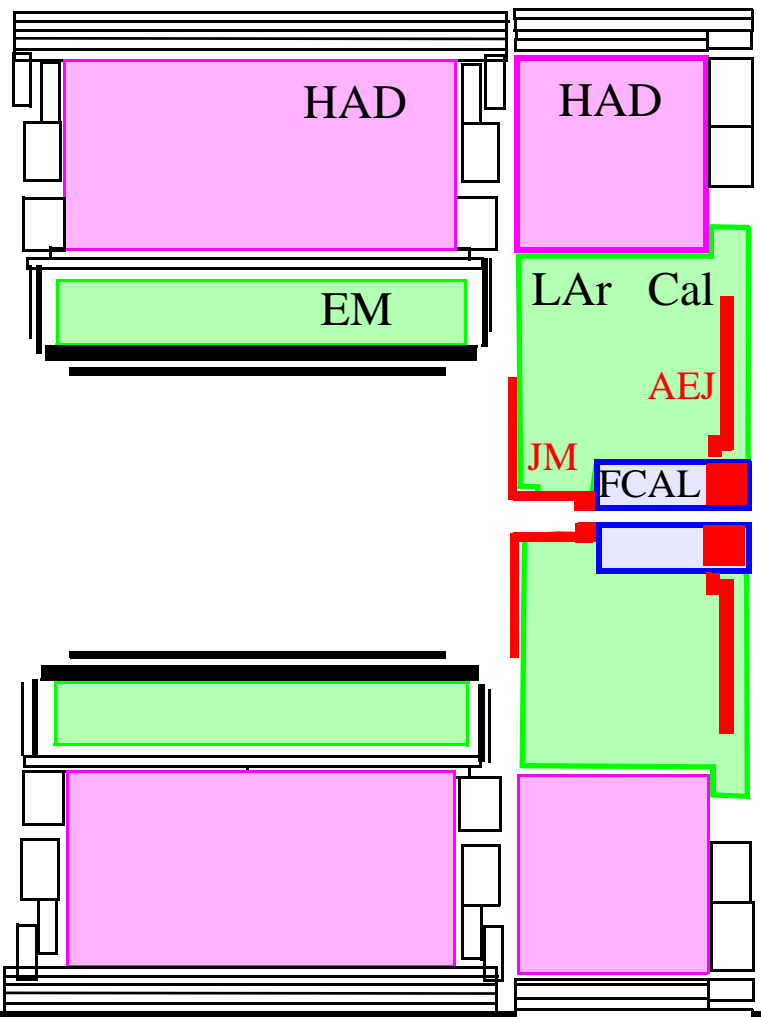

ACCESS

Rails

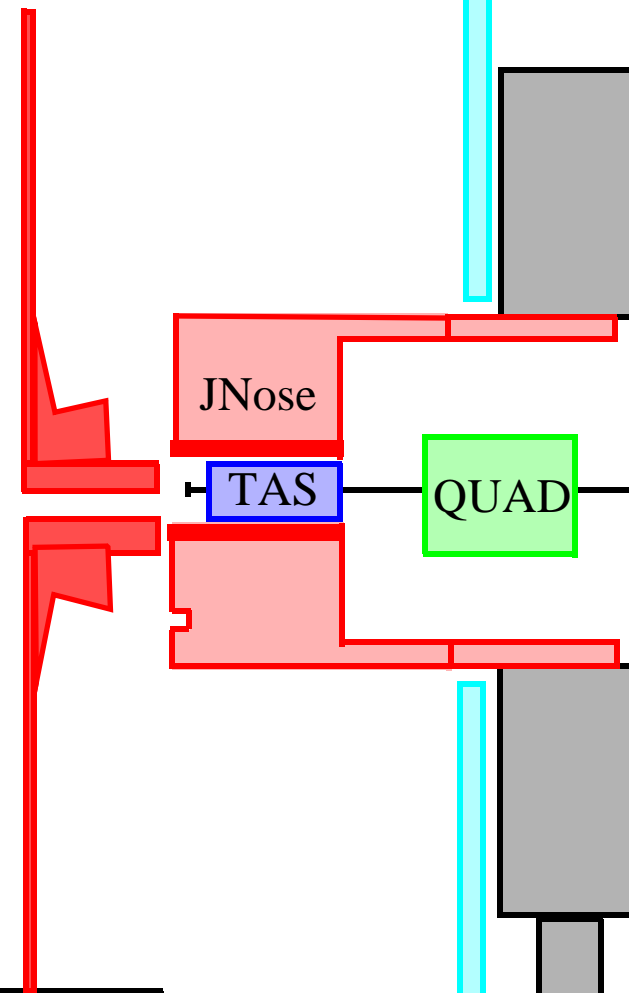
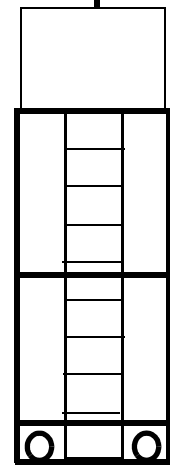
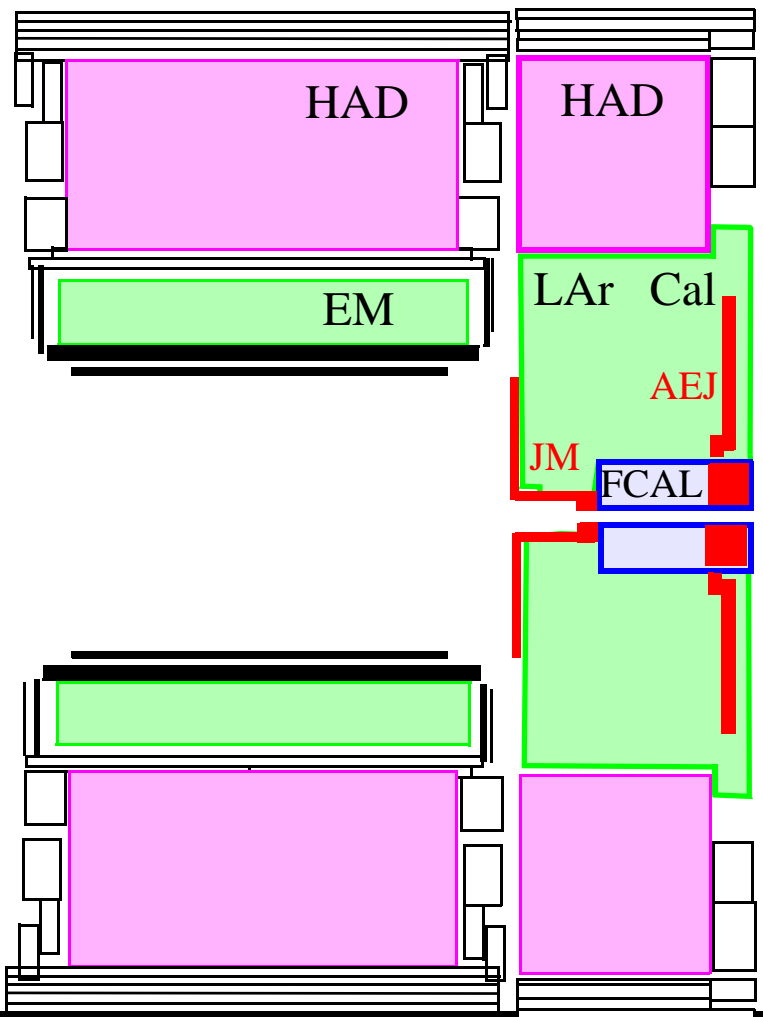

ACCESS

Rails

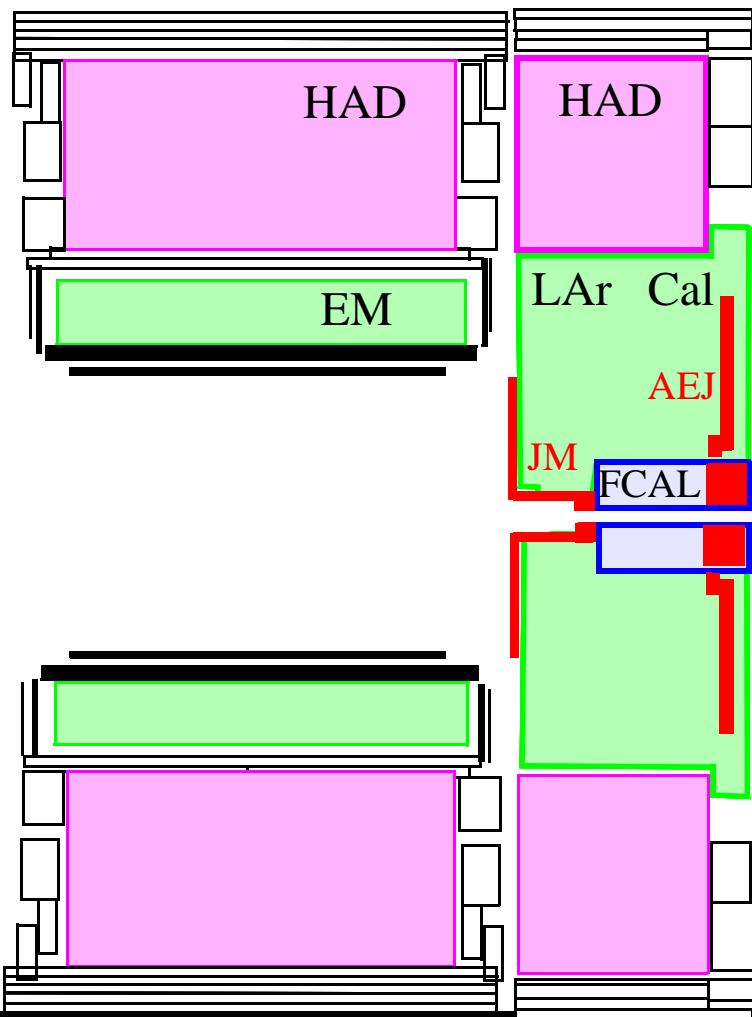

ACCESS

Rails

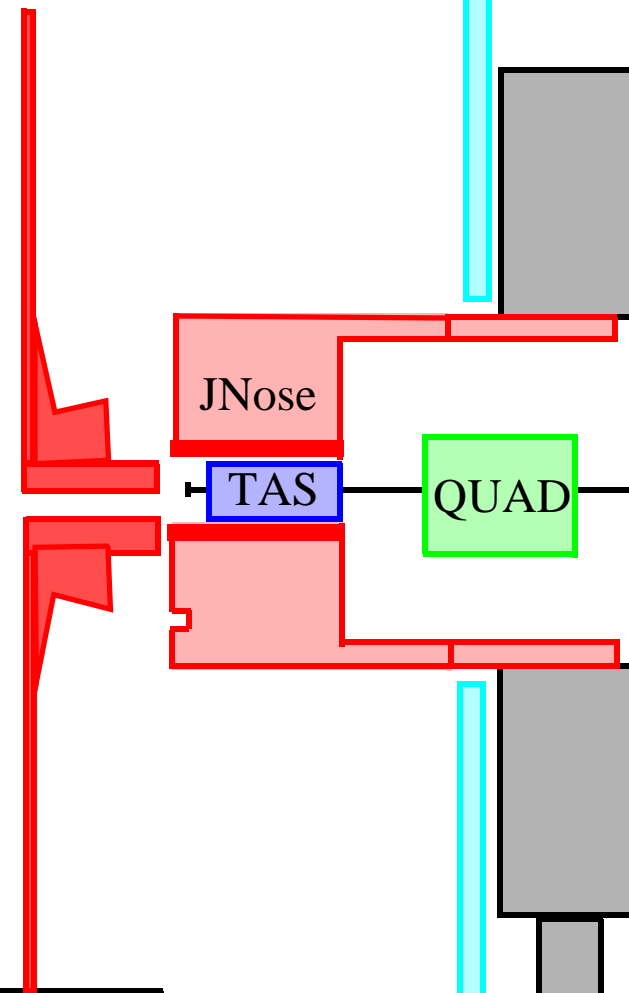
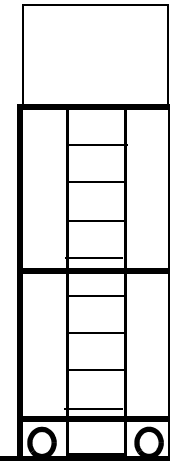

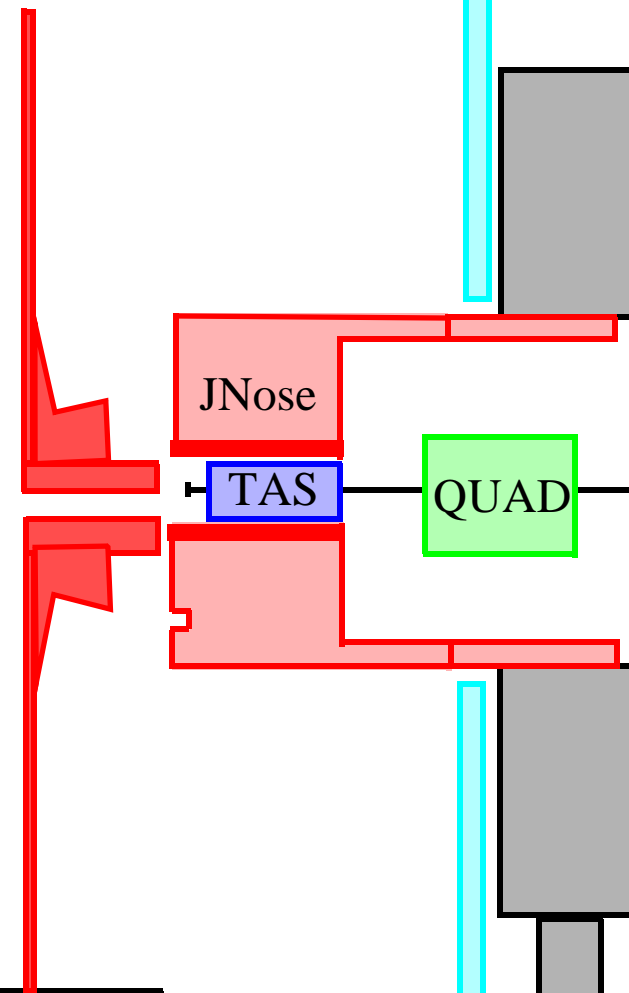
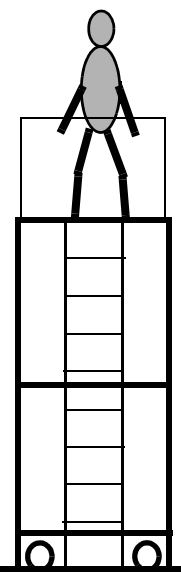
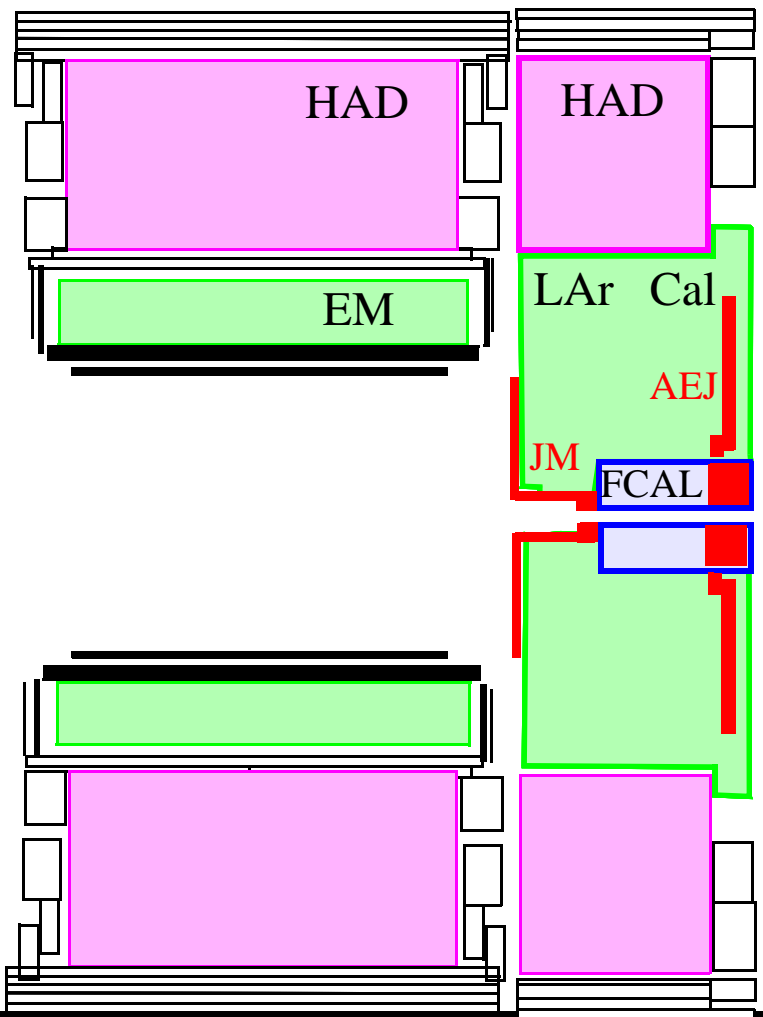

ACCESS

Rails

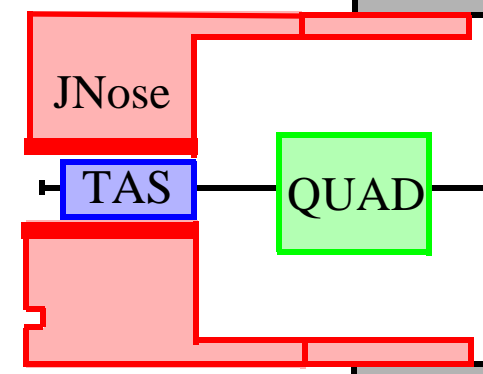
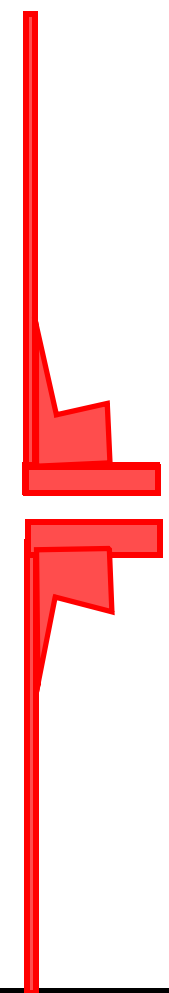
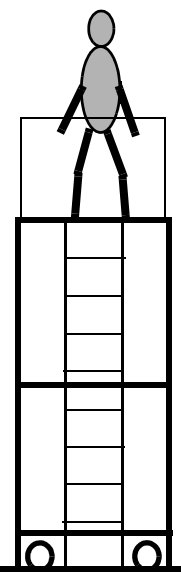
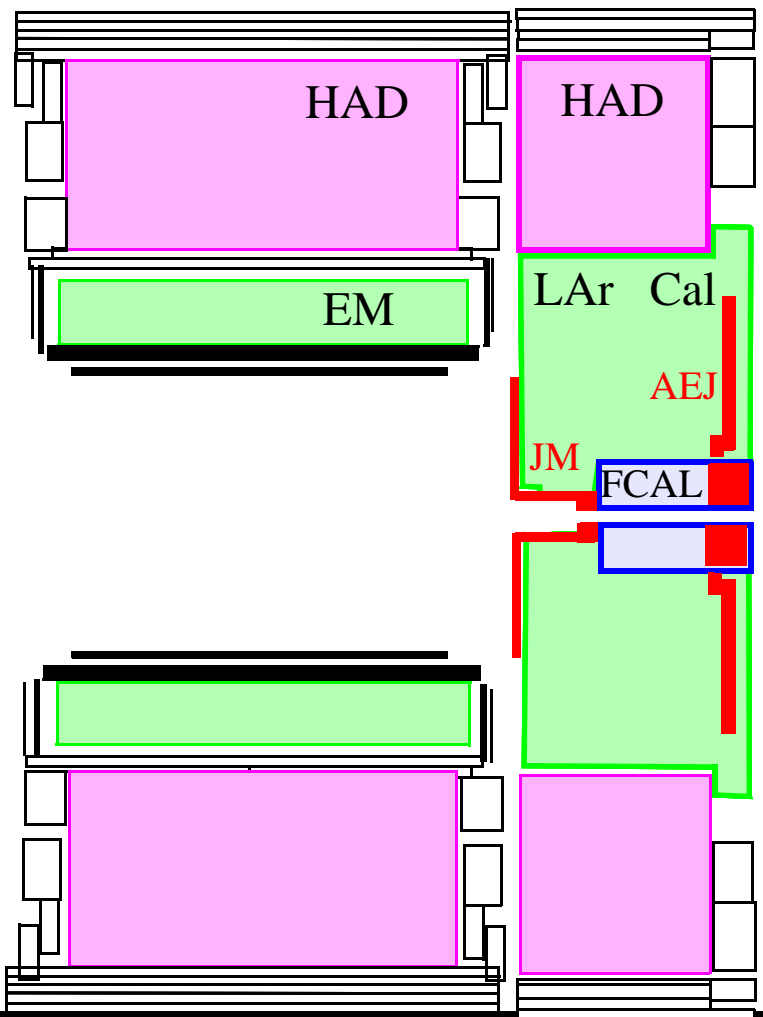

ACCESS

Rails

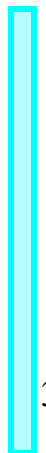
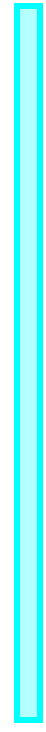
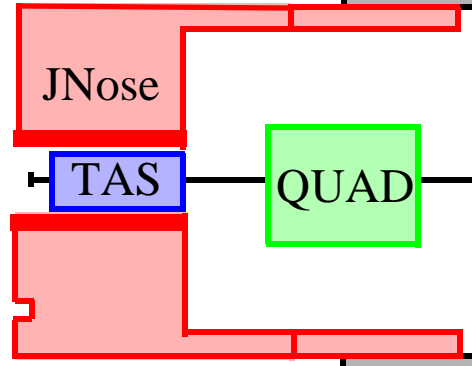
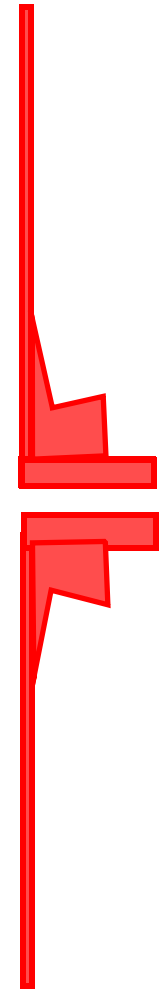
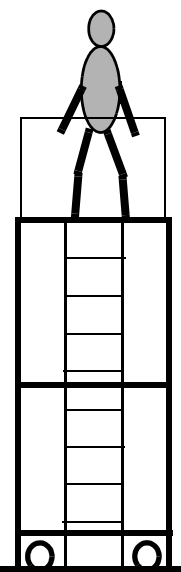
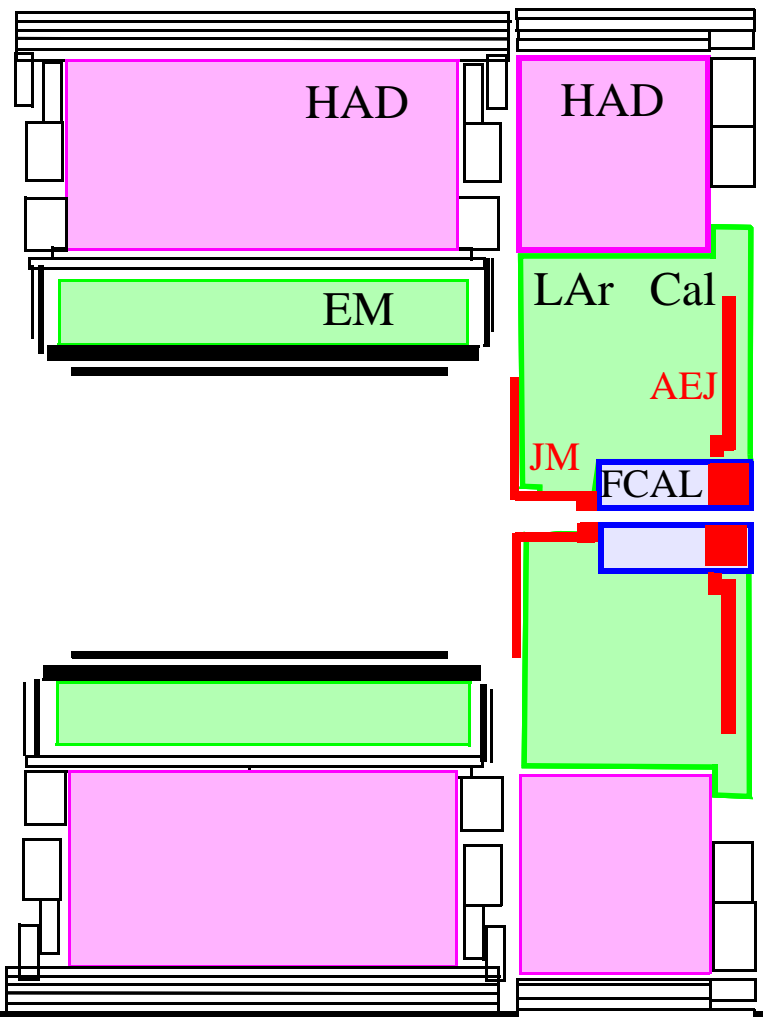

ACCESS

Rails

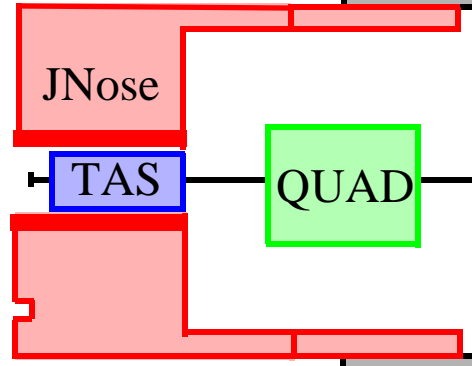
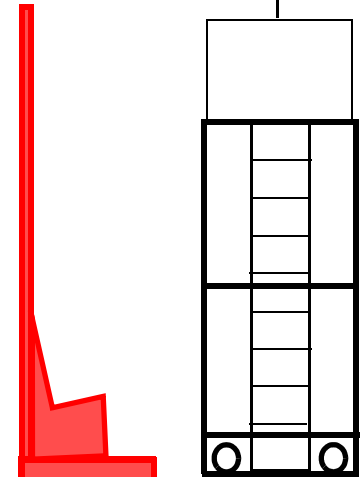
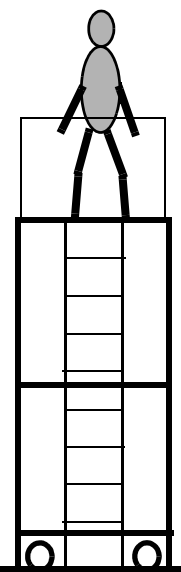
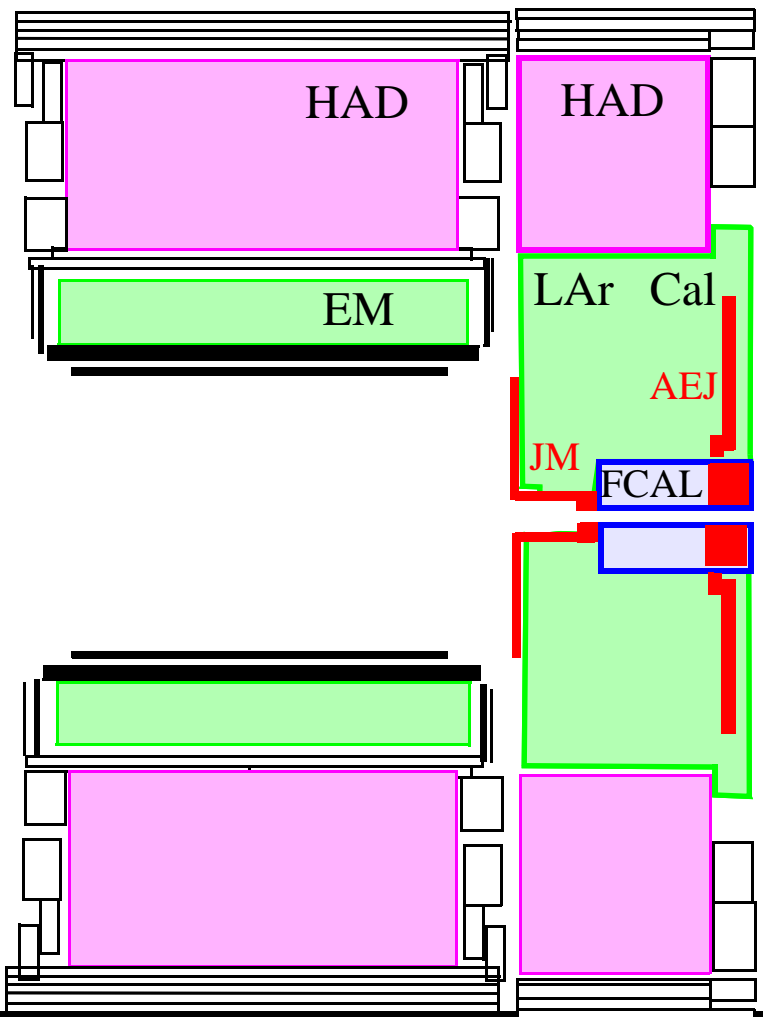

Rails

ACCESS

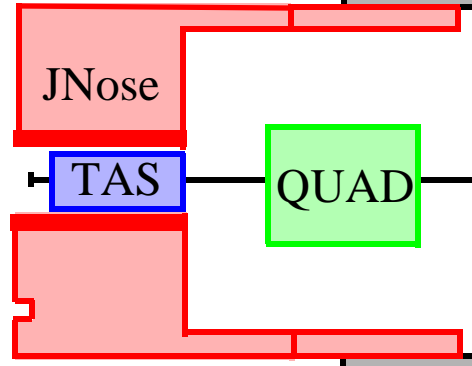
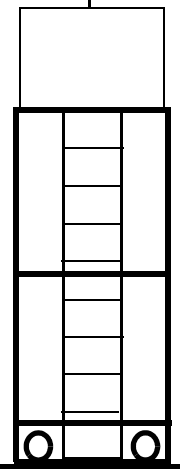
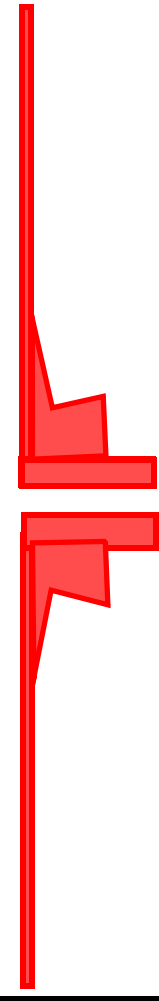
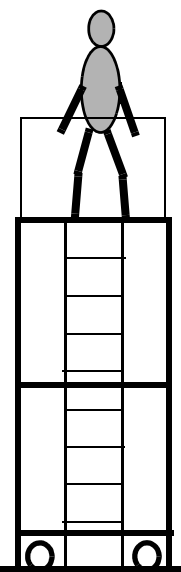
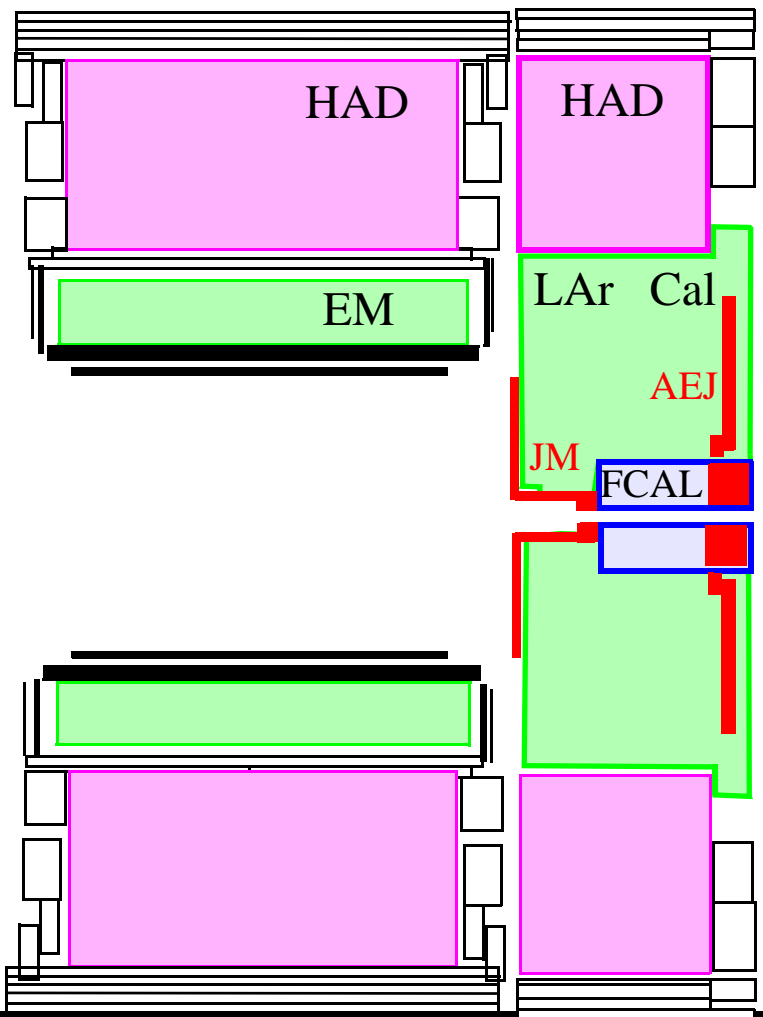

Rails

ACCESS

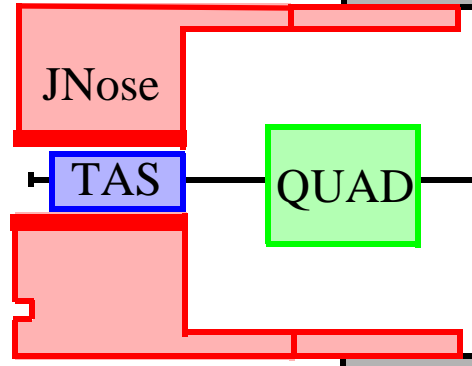
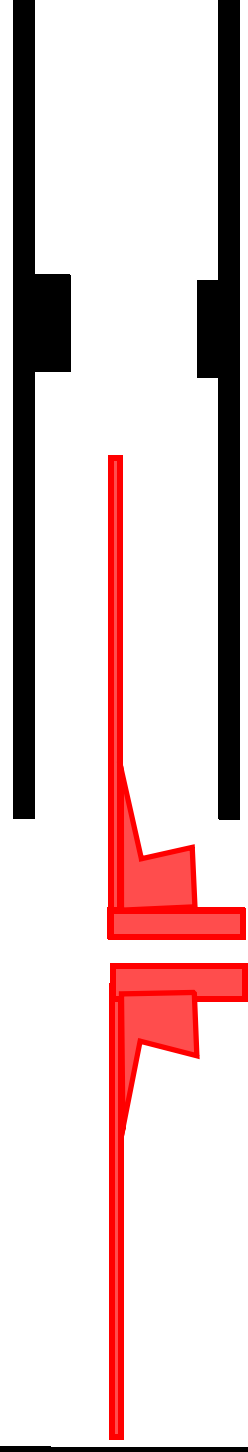
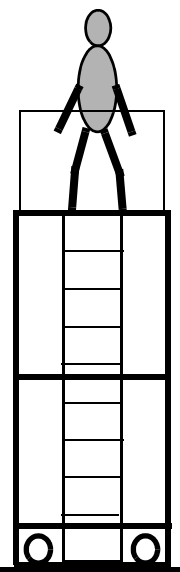
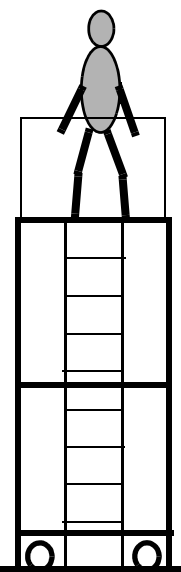
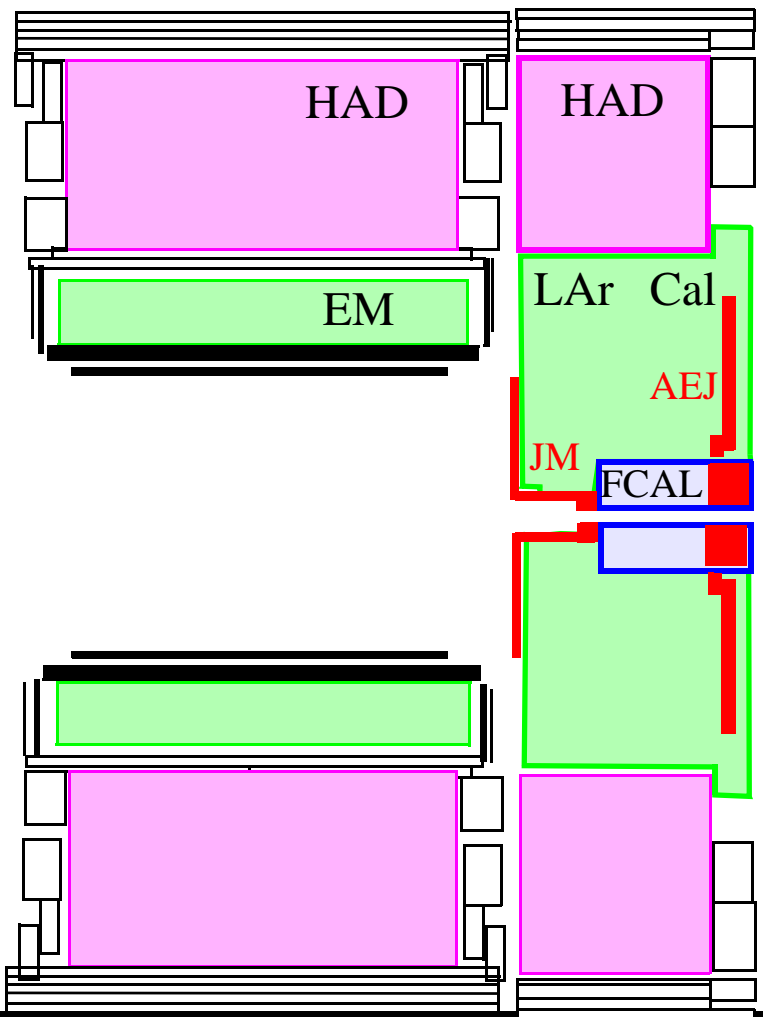

ACCESS

Rails

40

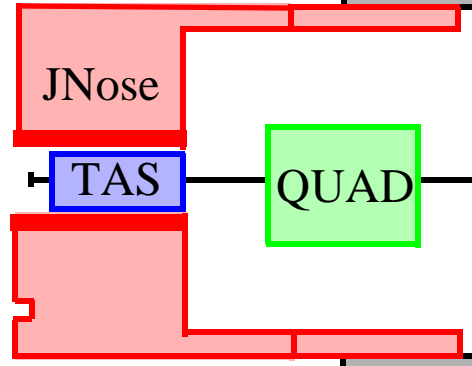
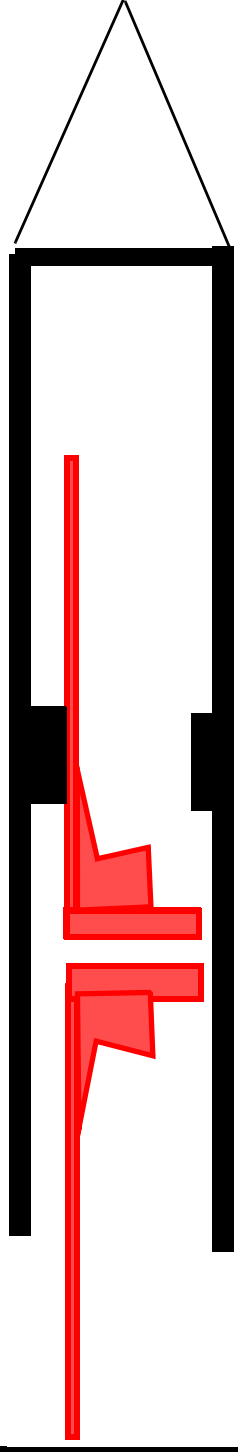
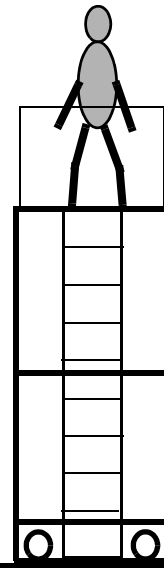
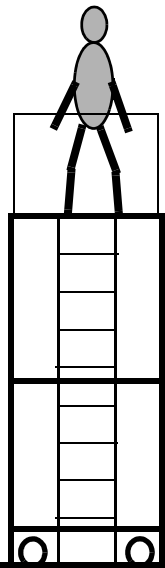
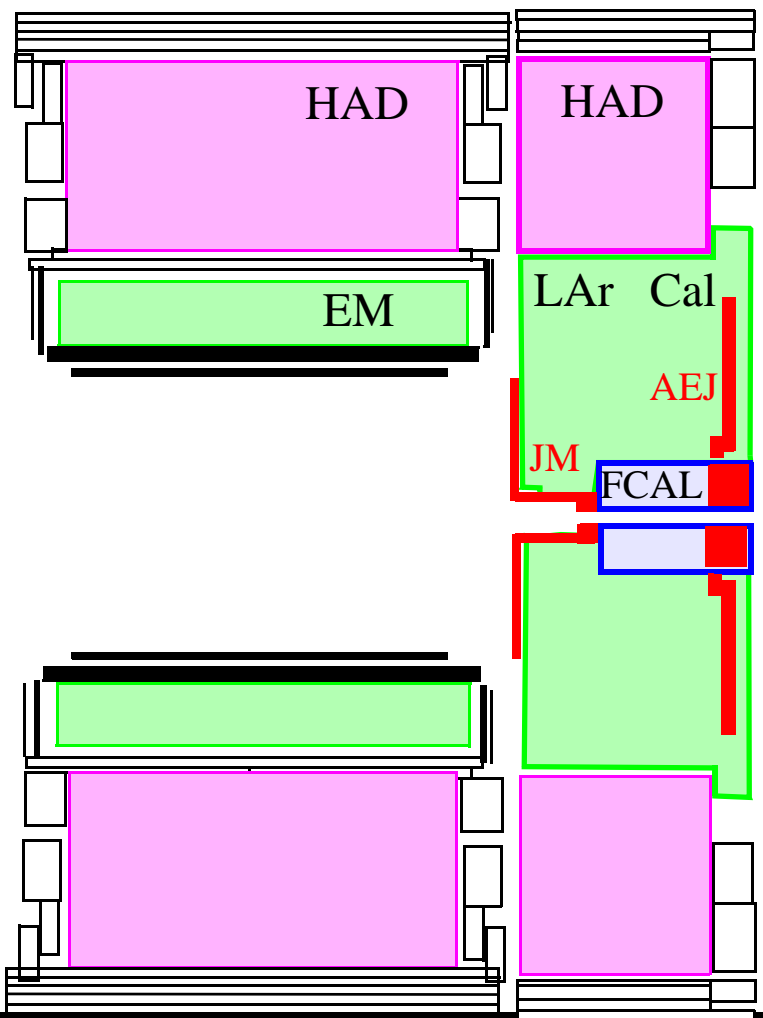

Rails

ACCESS

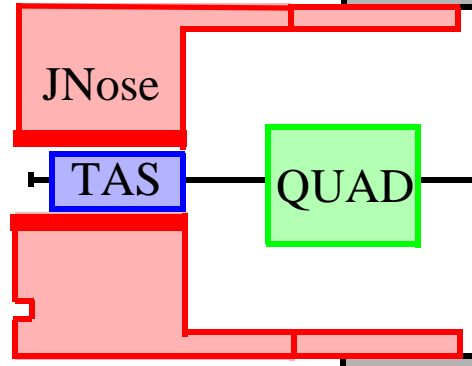
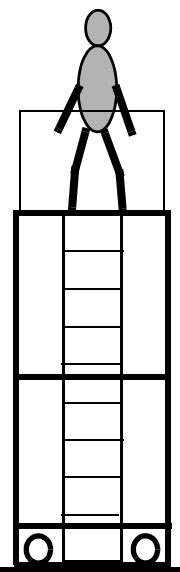
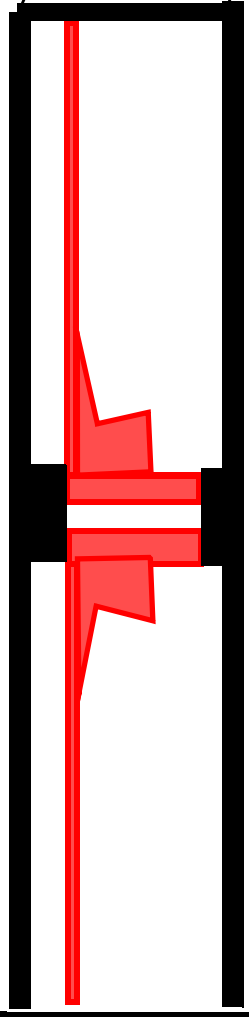
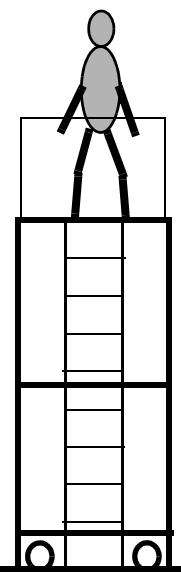
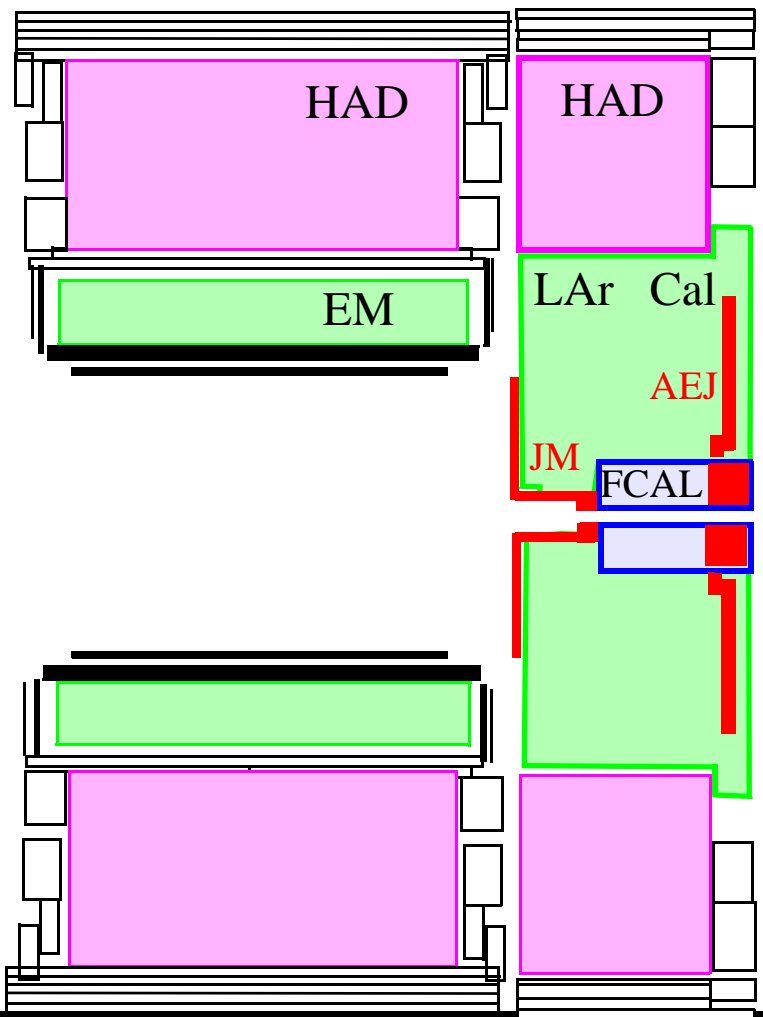

ACCESS
Rails

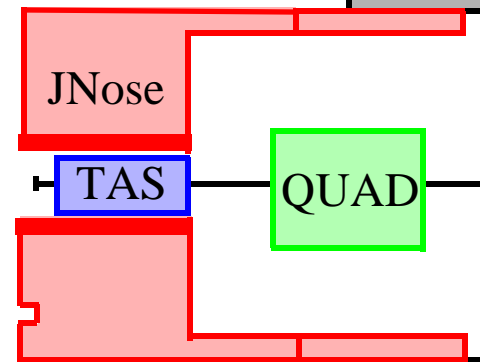
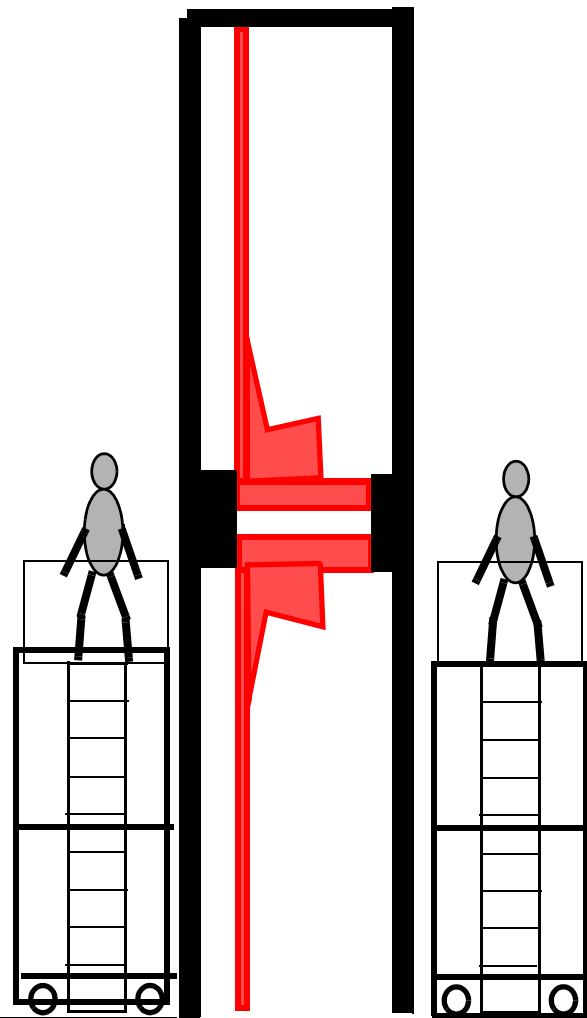
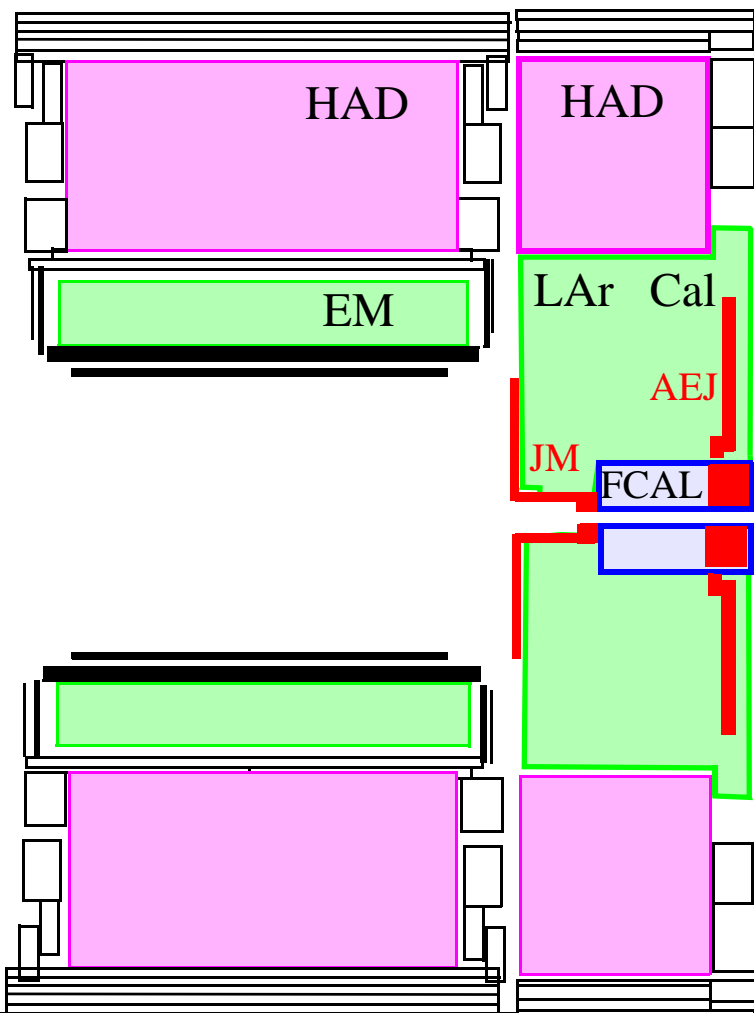

ACCESS

Rails

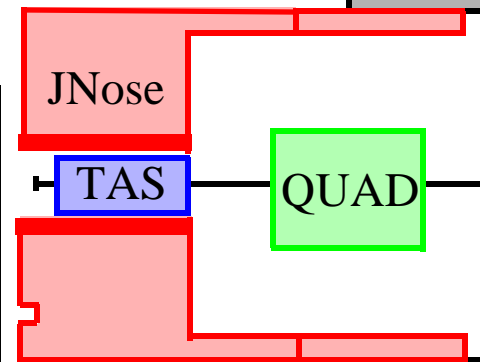
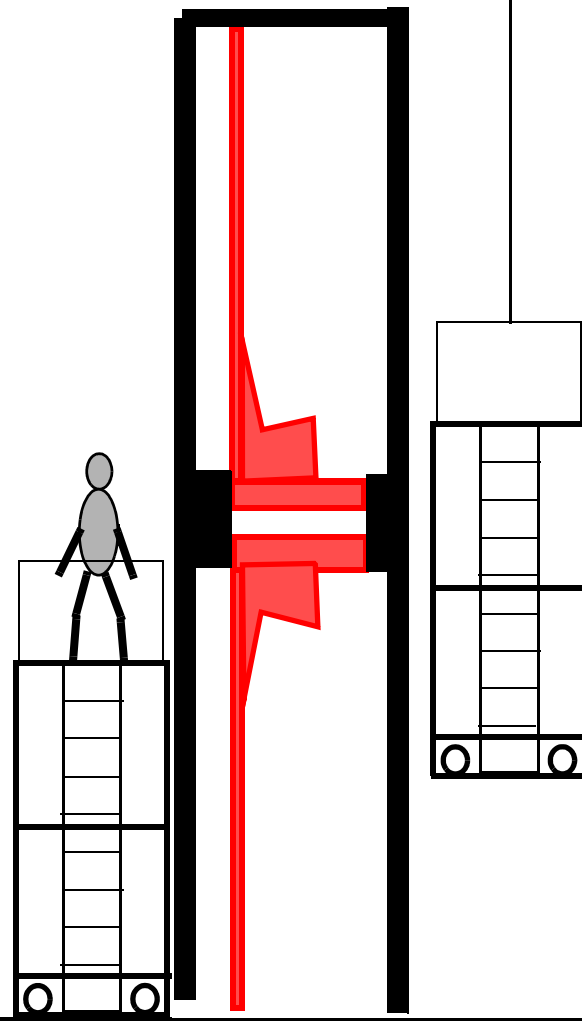
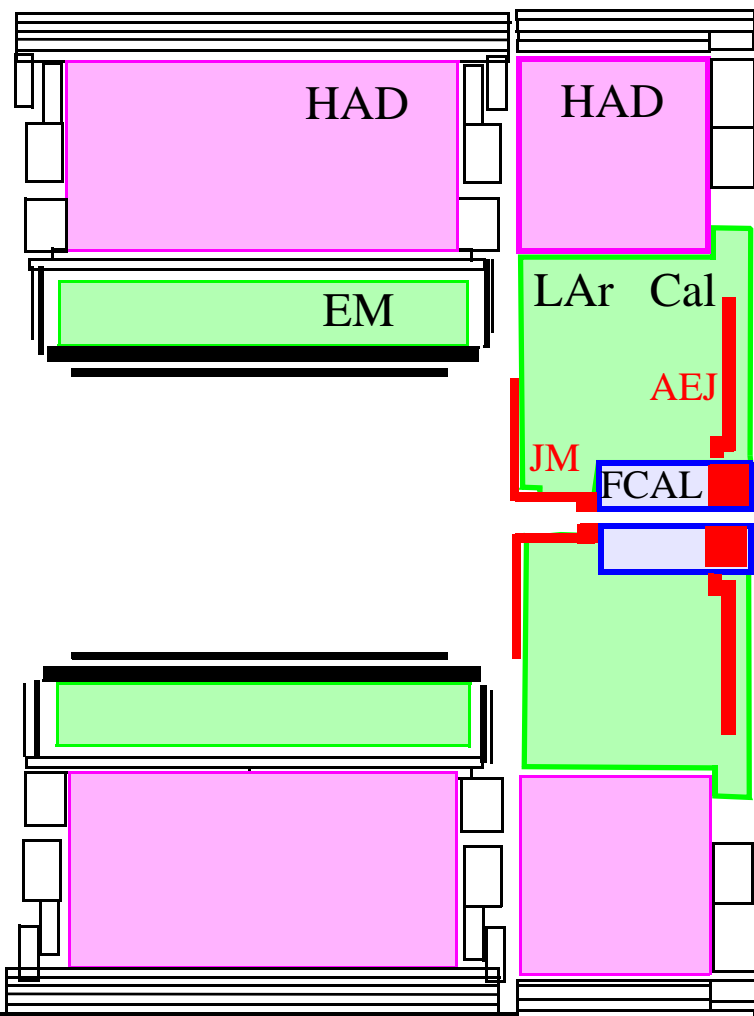

Rails

ACCESS

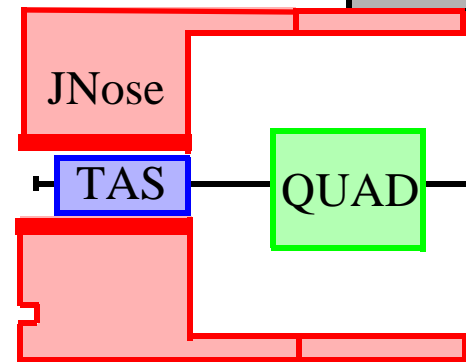
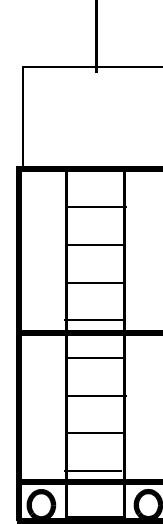
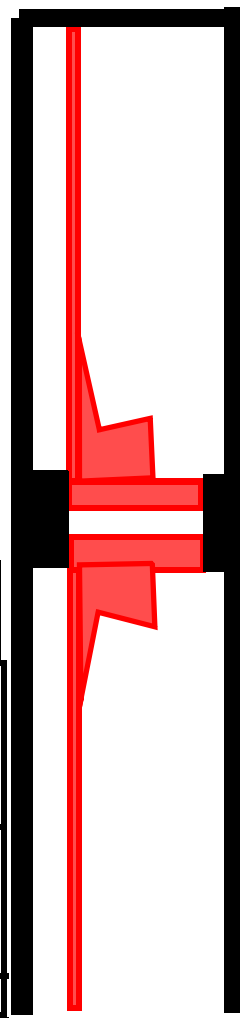
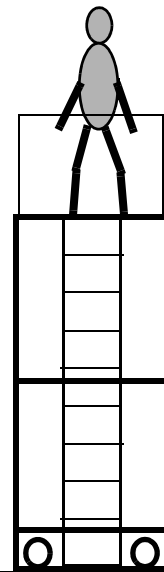
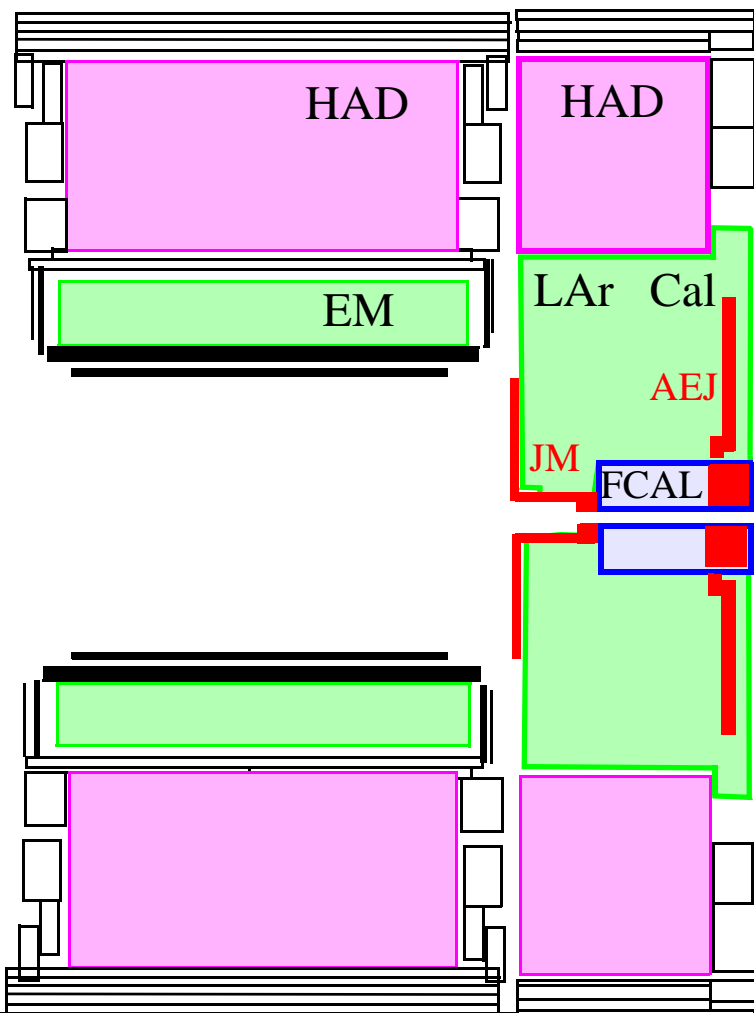

Rails

ACCESS

45

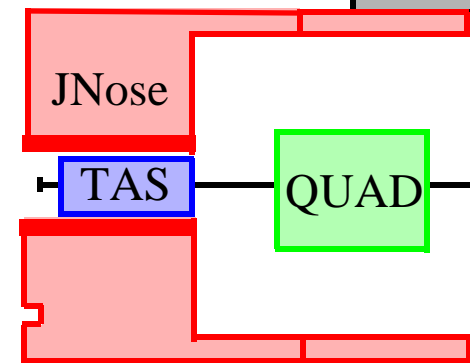
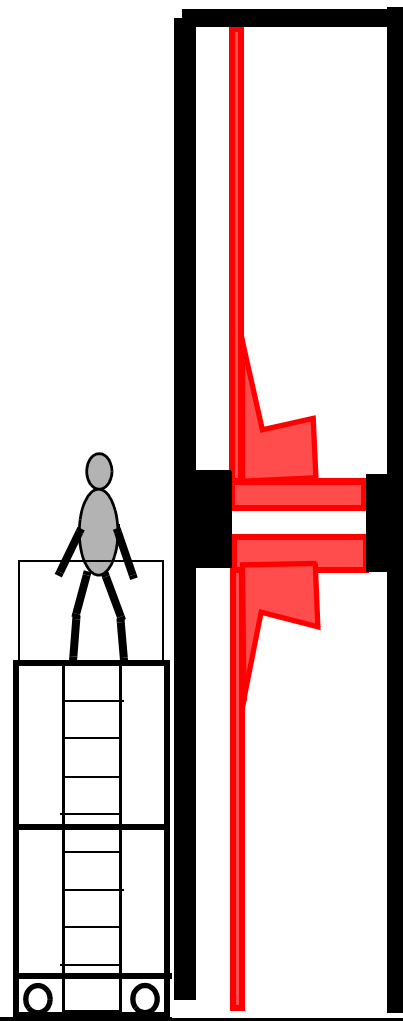
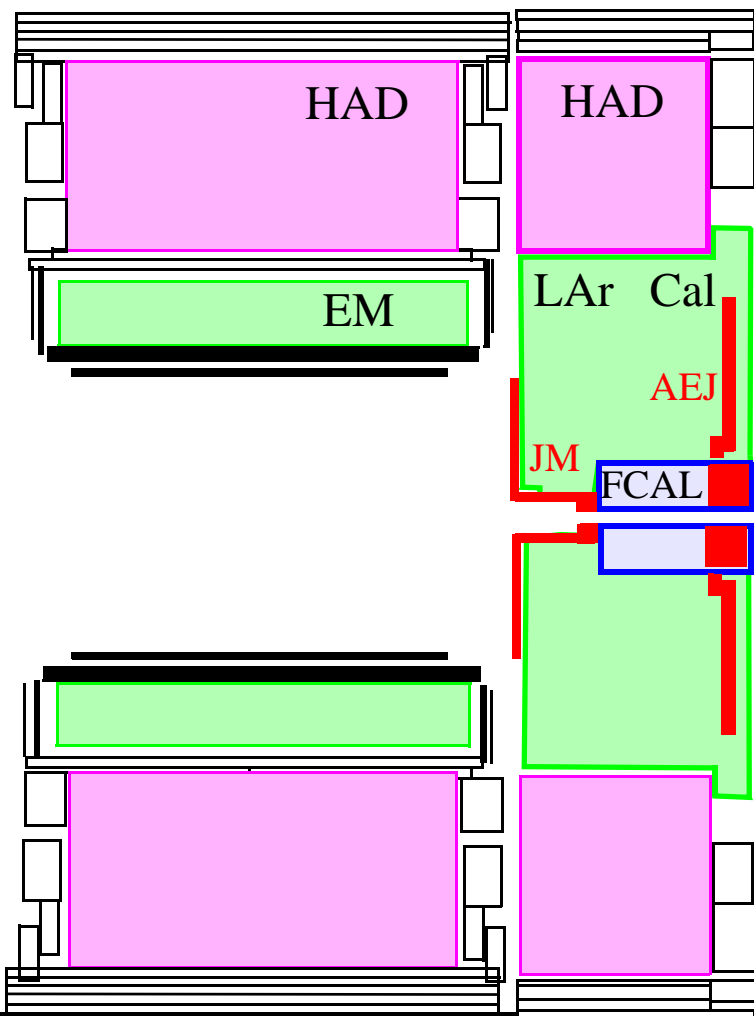

ACCESS

Rails

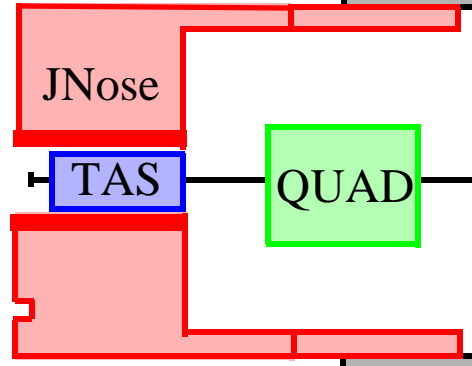
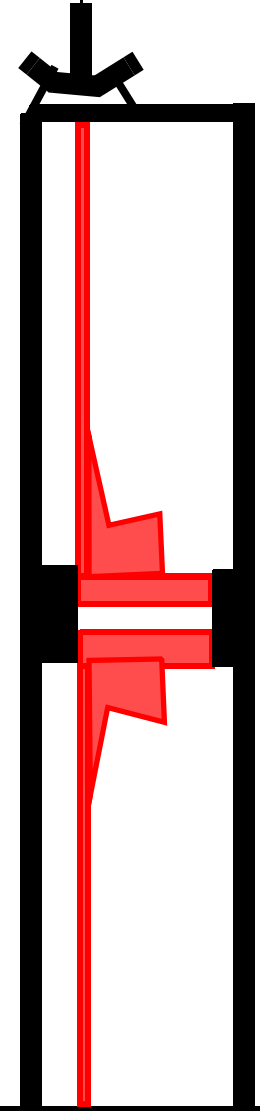
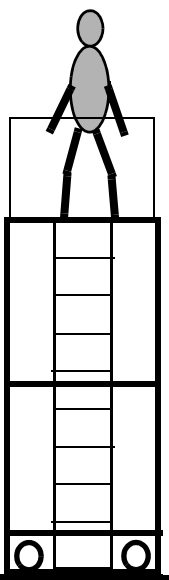
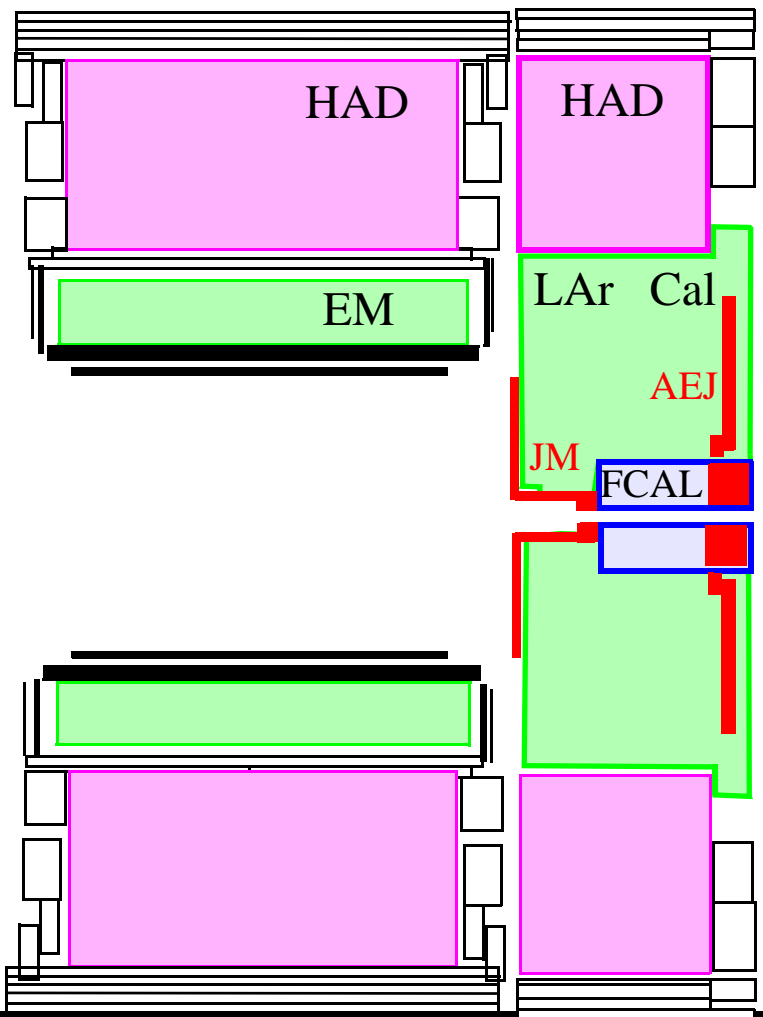

ACCESS
Rails

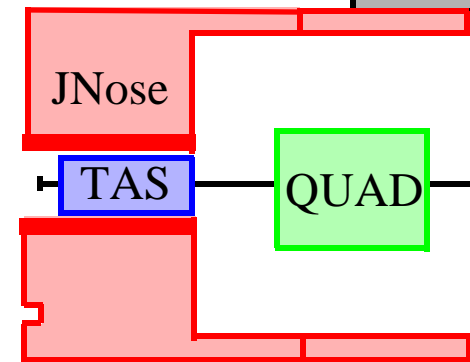
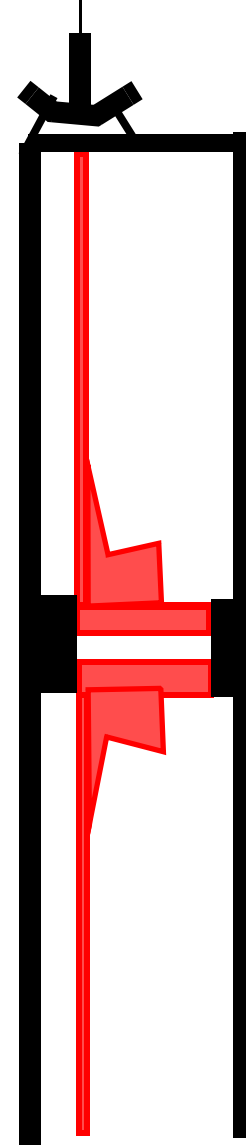
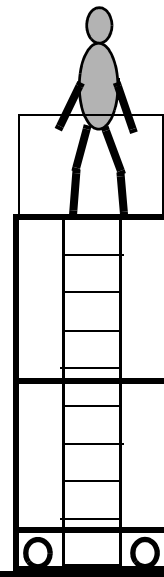
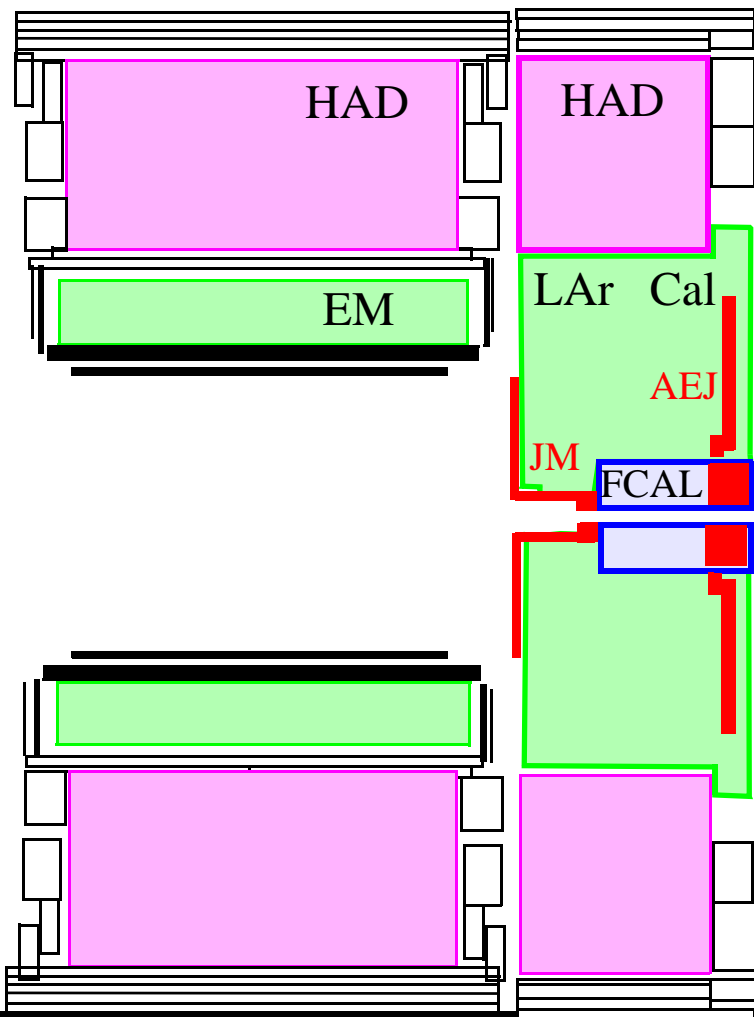

Rails

ACCESS

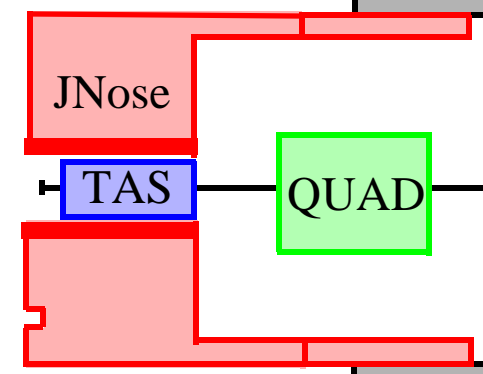
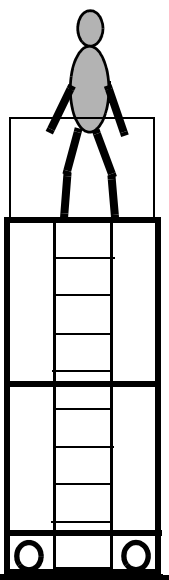
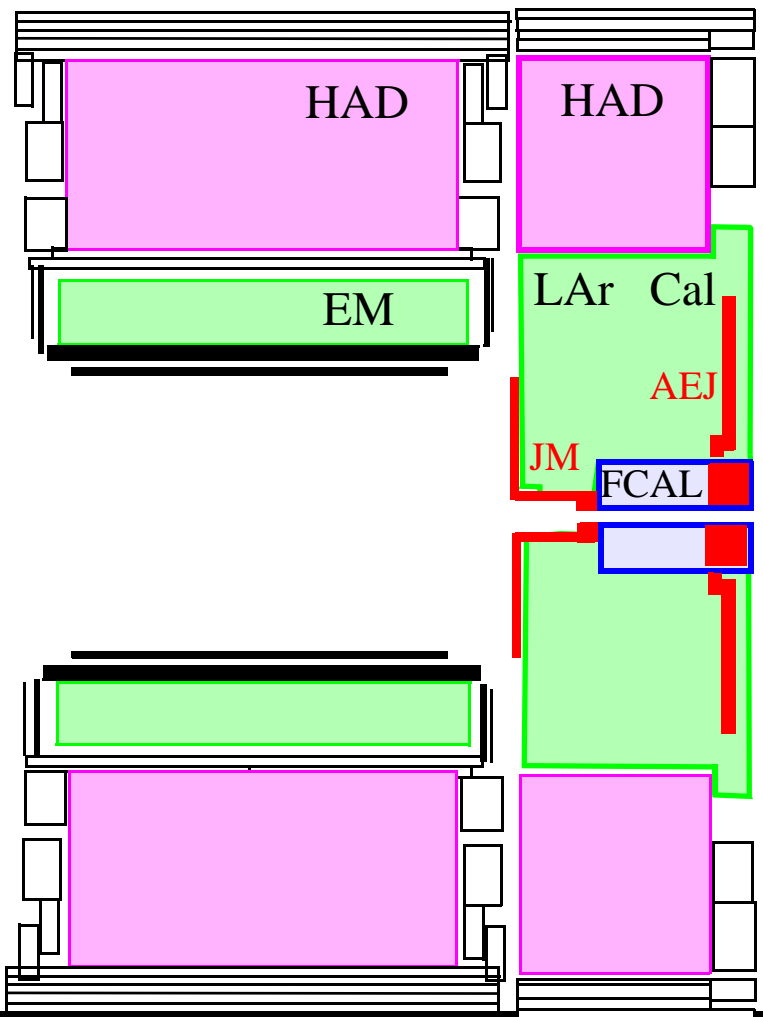

ACCESS

Rails

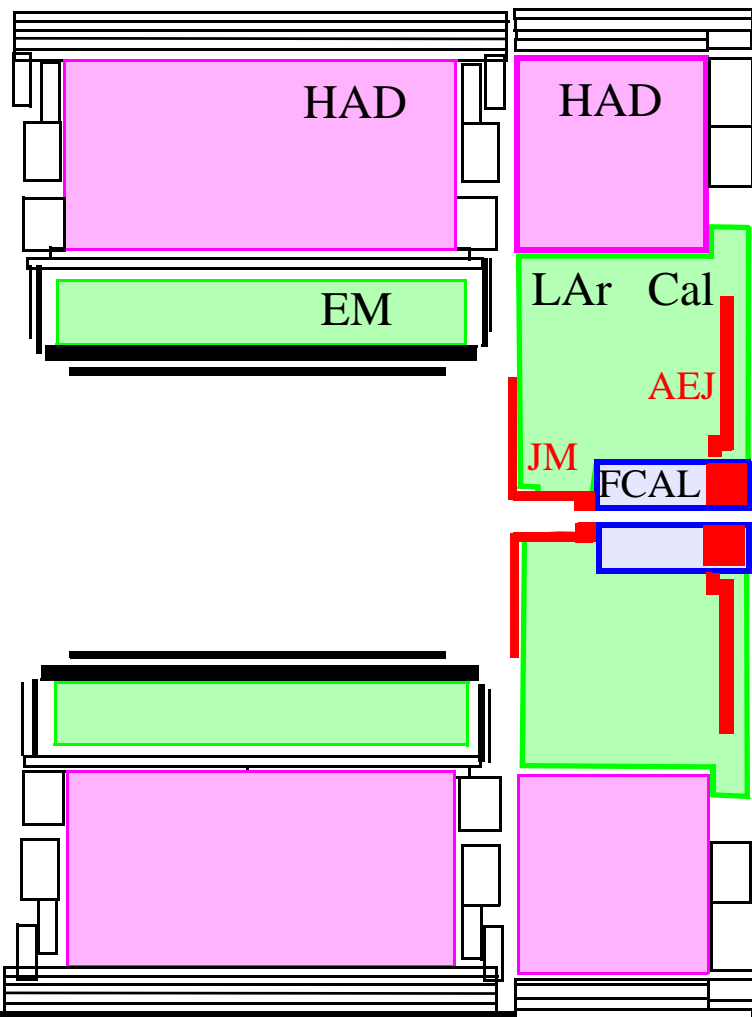

ACCESS

Rails

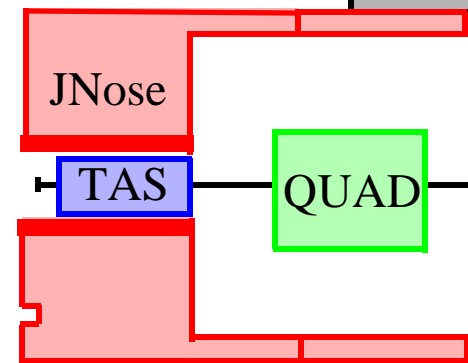
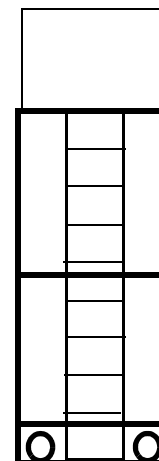

50

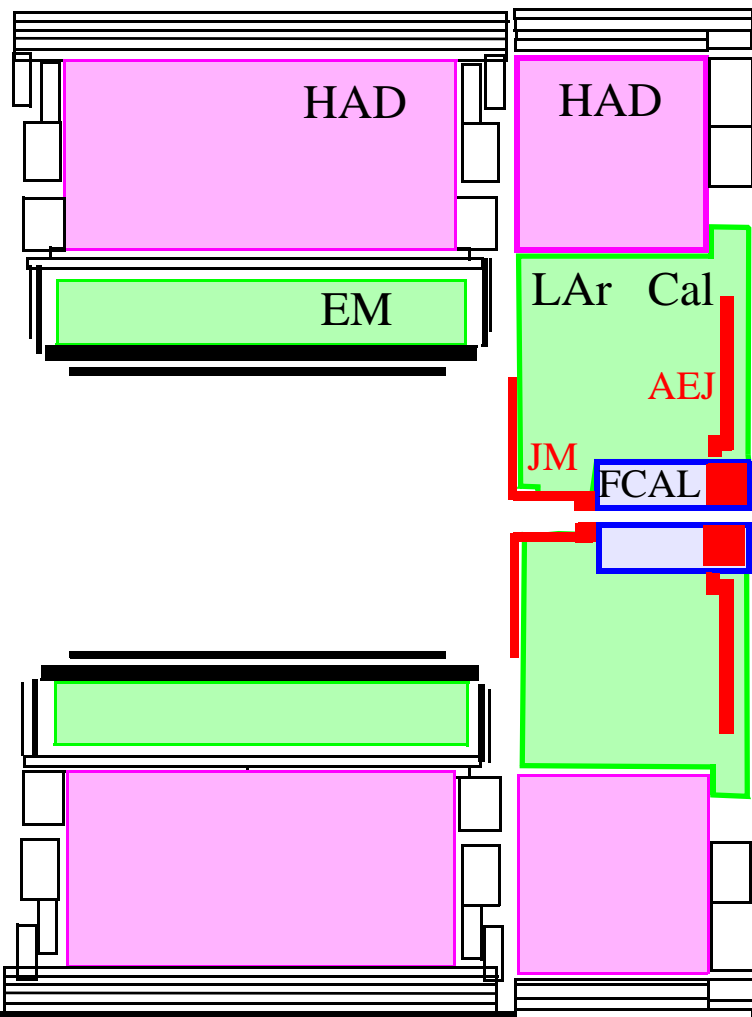

ACCESS

Rails

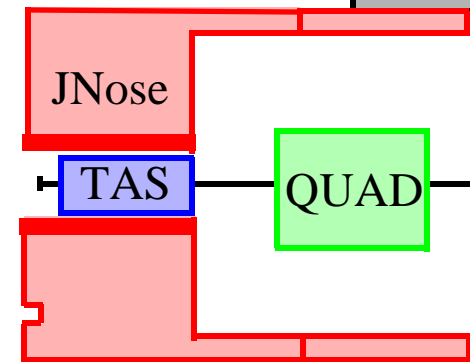
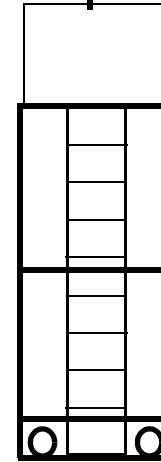

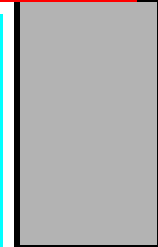
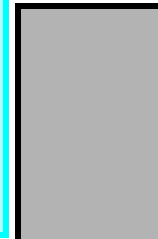
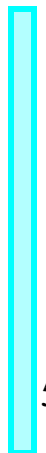
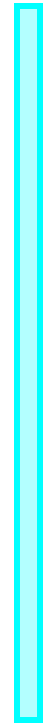
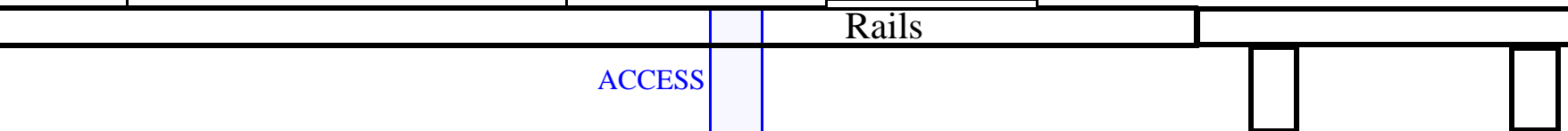
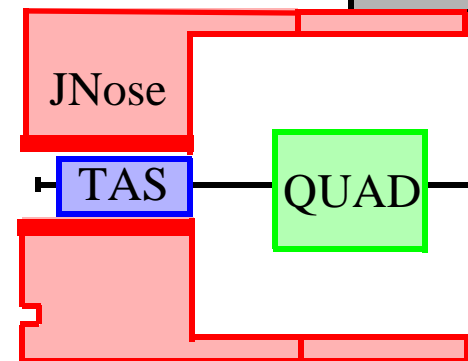
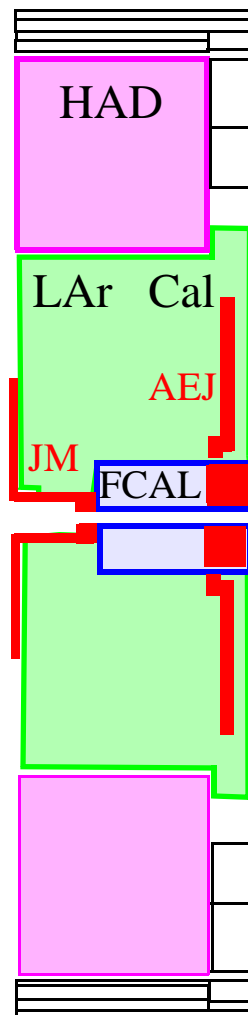
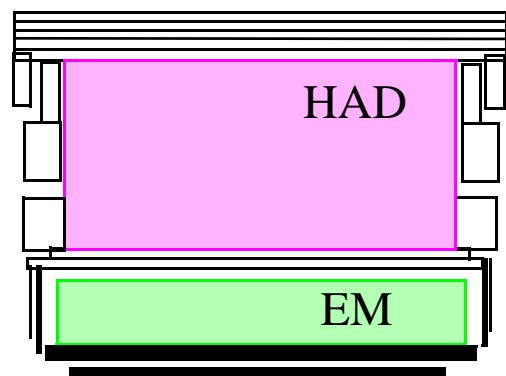

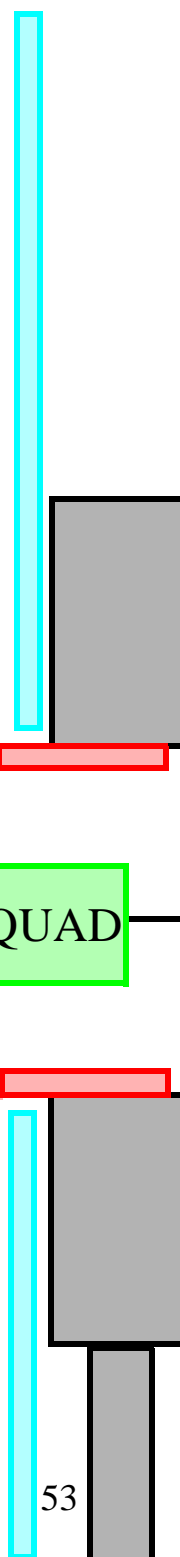
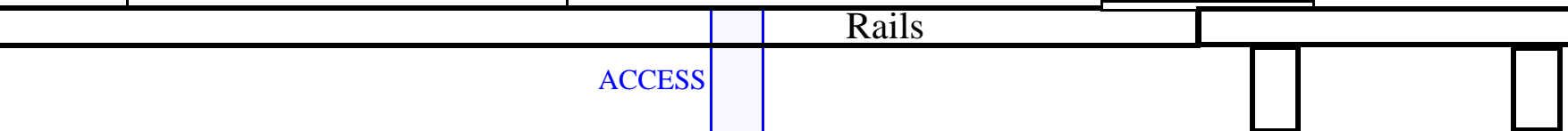
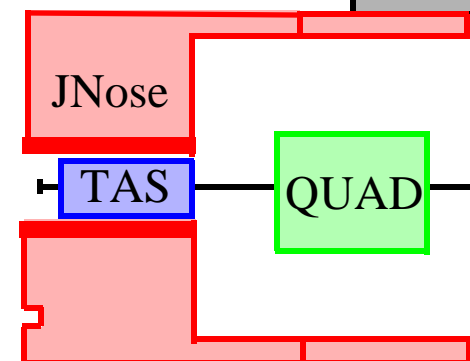
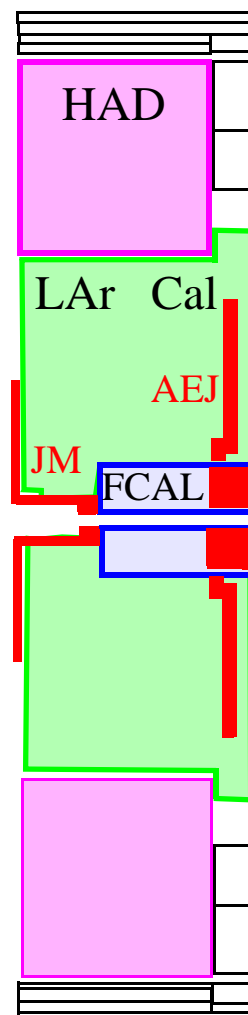
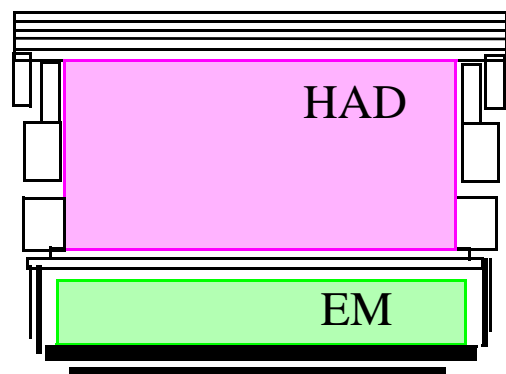

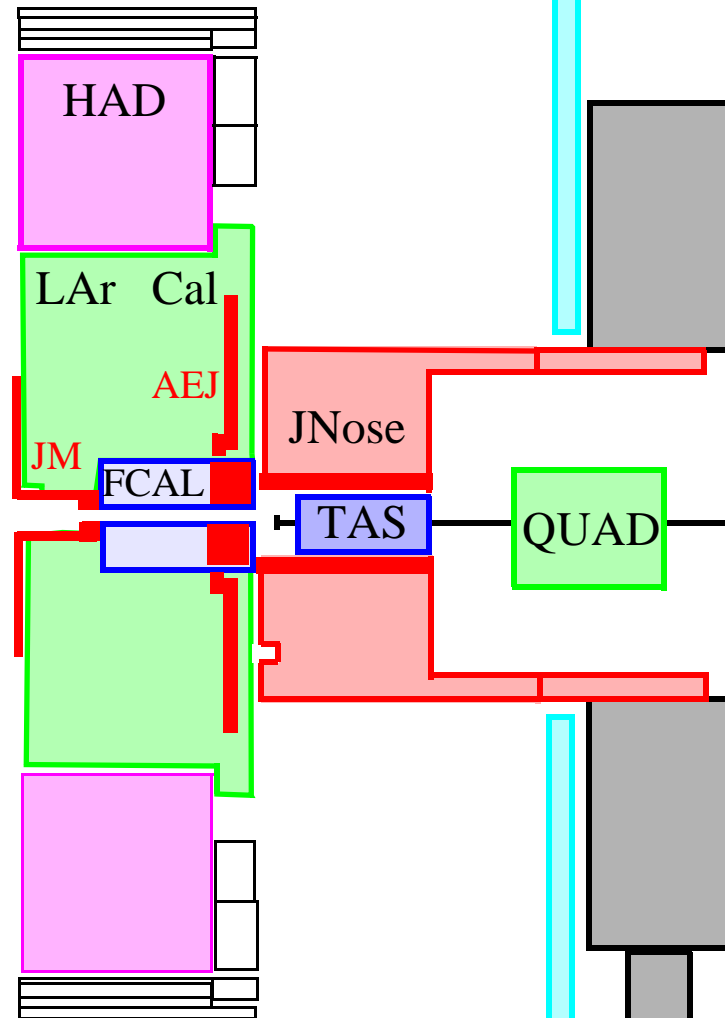
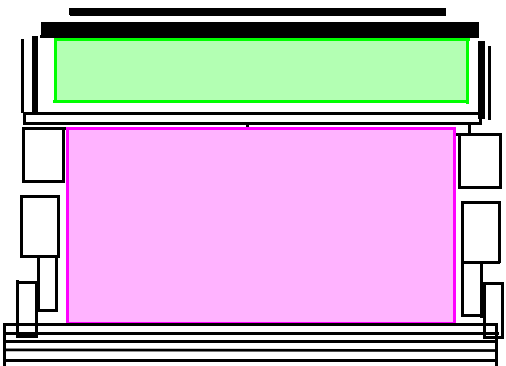
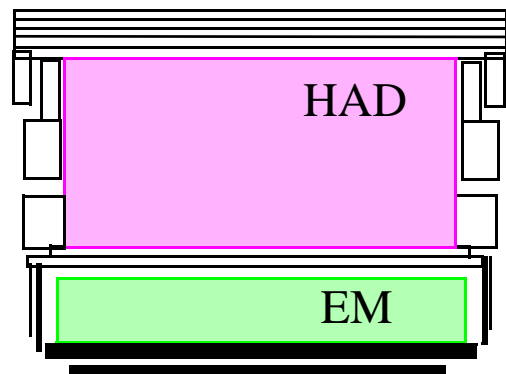

ACCESS

Rails

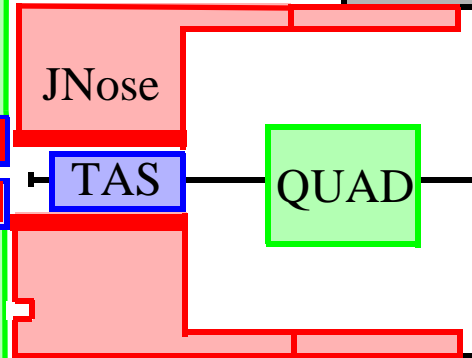
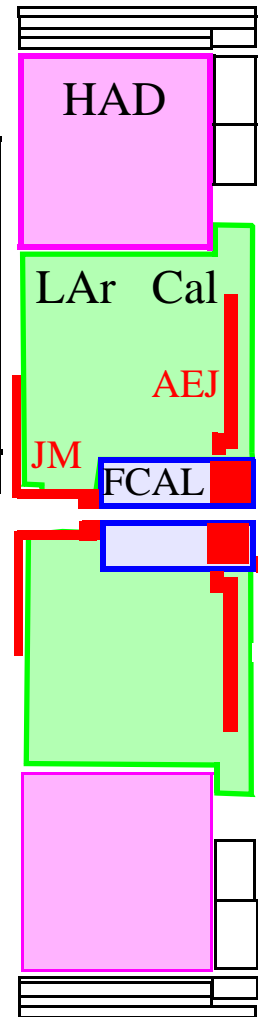
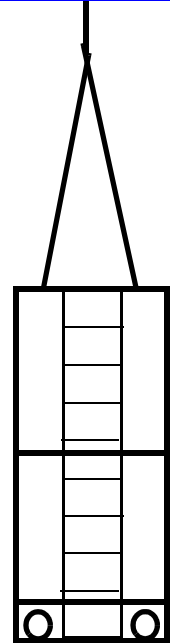
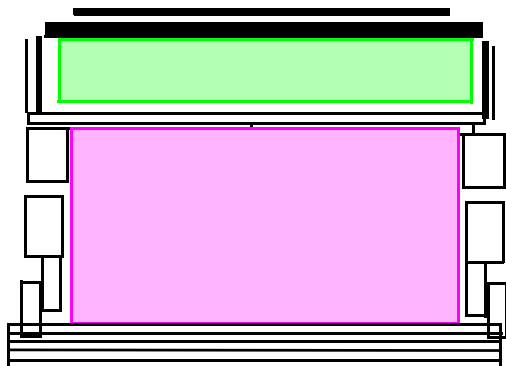
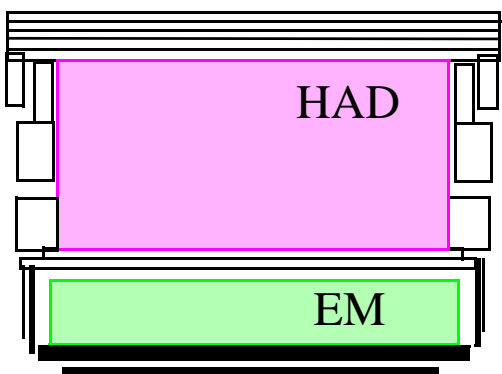

ACCESS

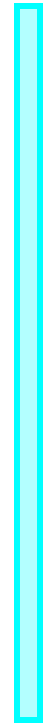

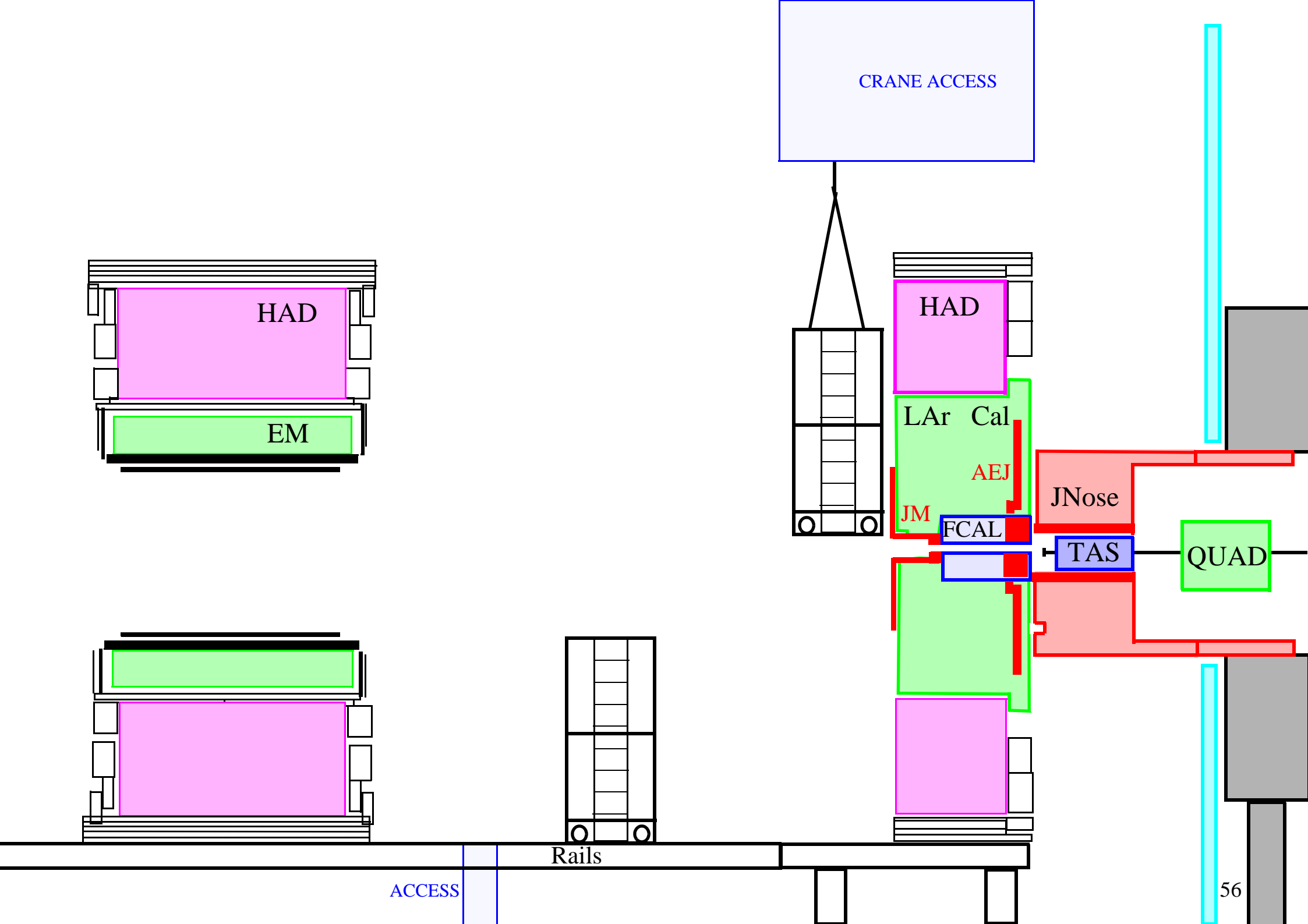

CRANE ACCESS

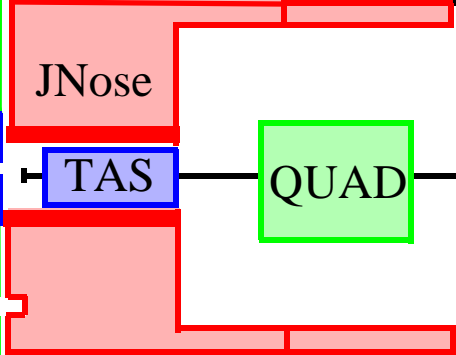
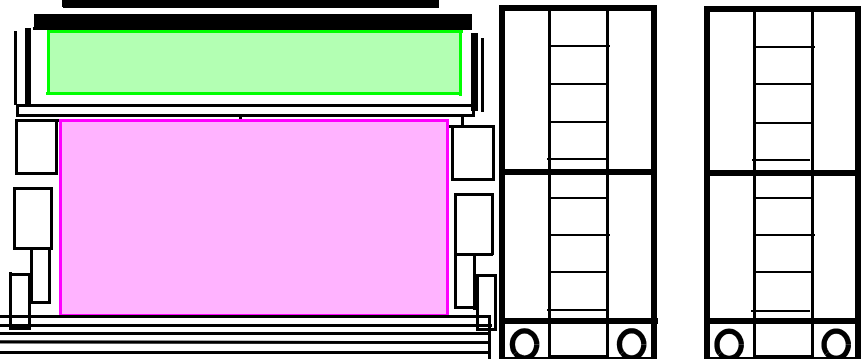
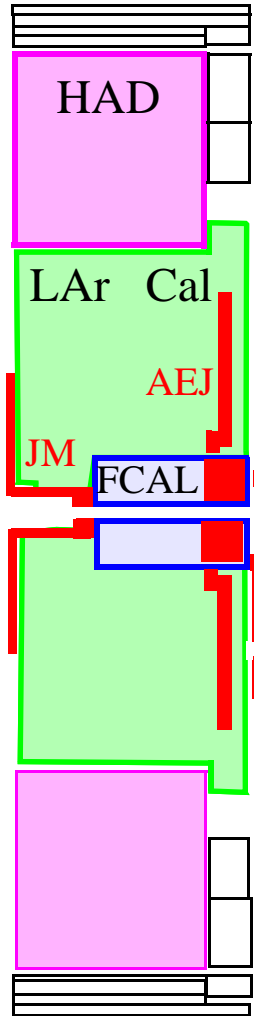
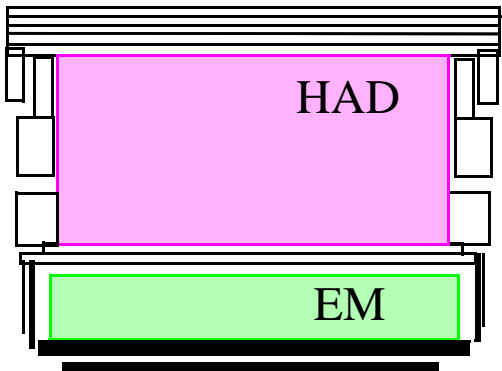

ACCESS

Rails

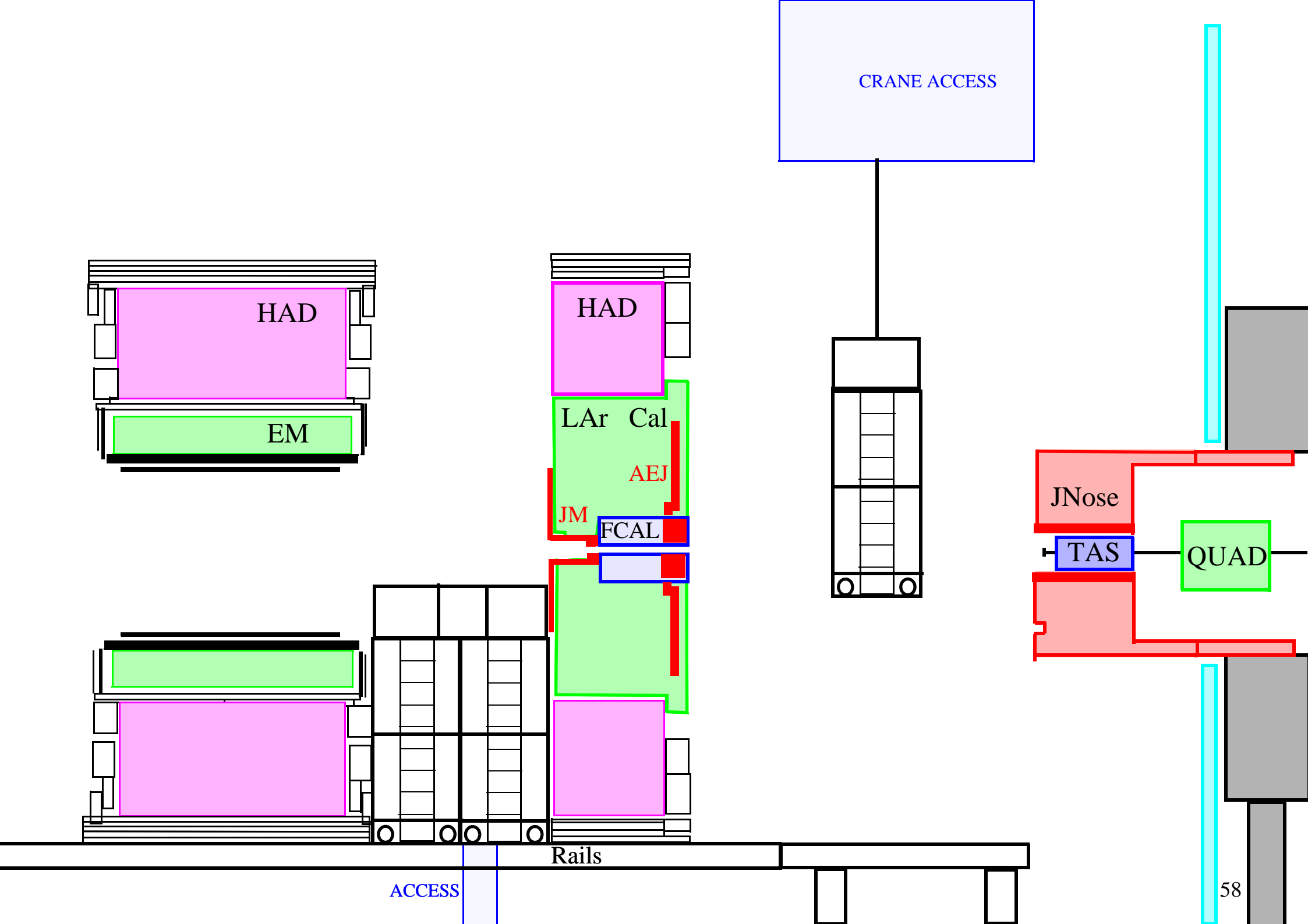

CRANE ACCESS

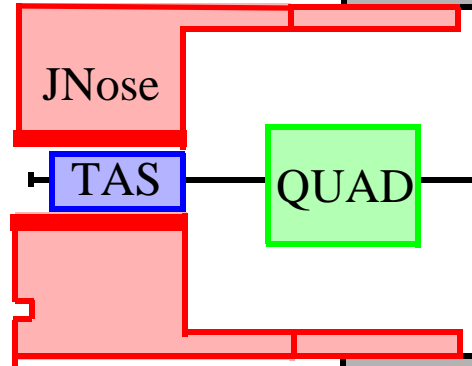
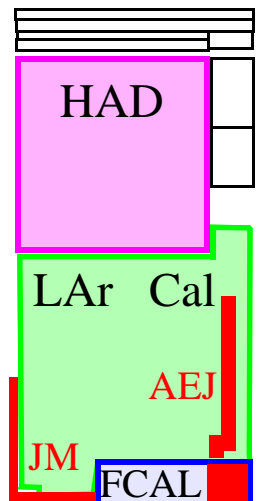
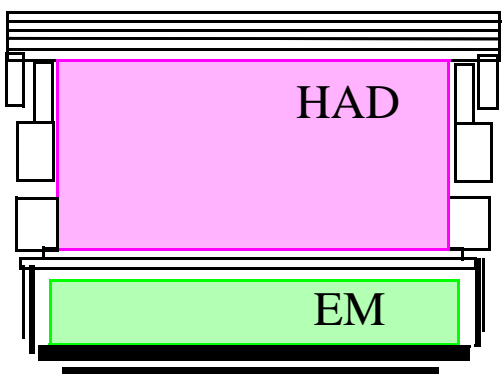

ACCESS

Rails

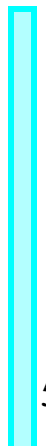
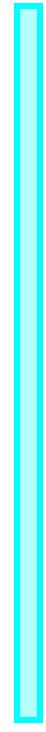

CRANE ACCESS

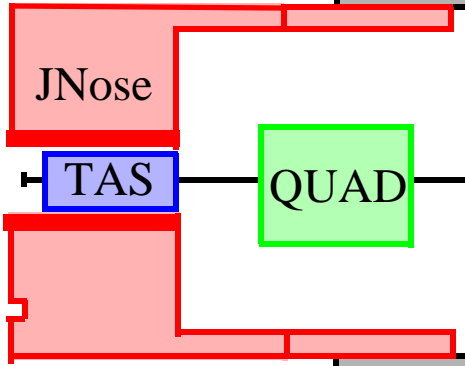
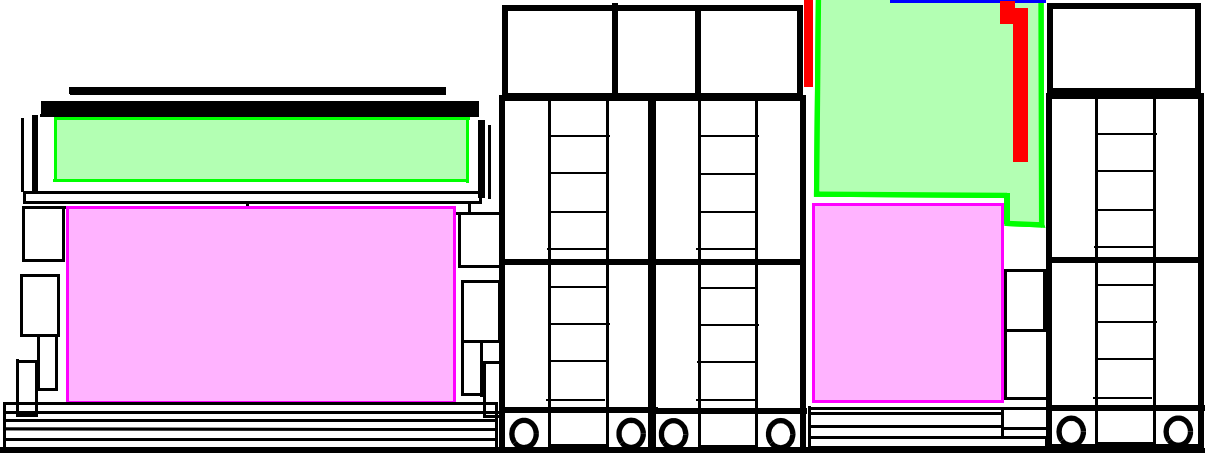
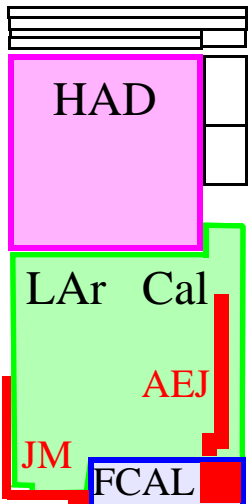
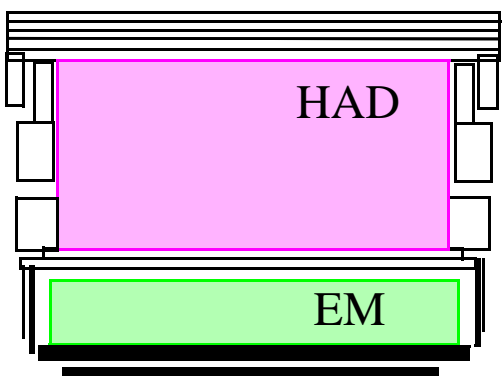

Rails

ACCESS

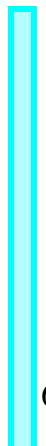
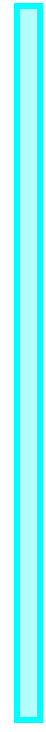

60

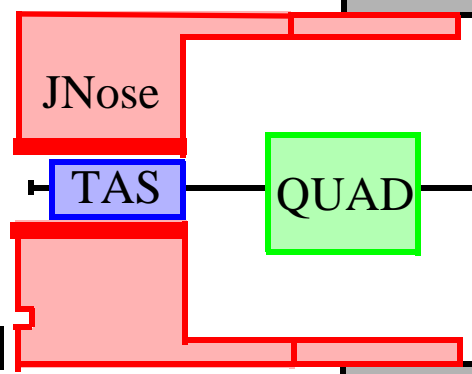
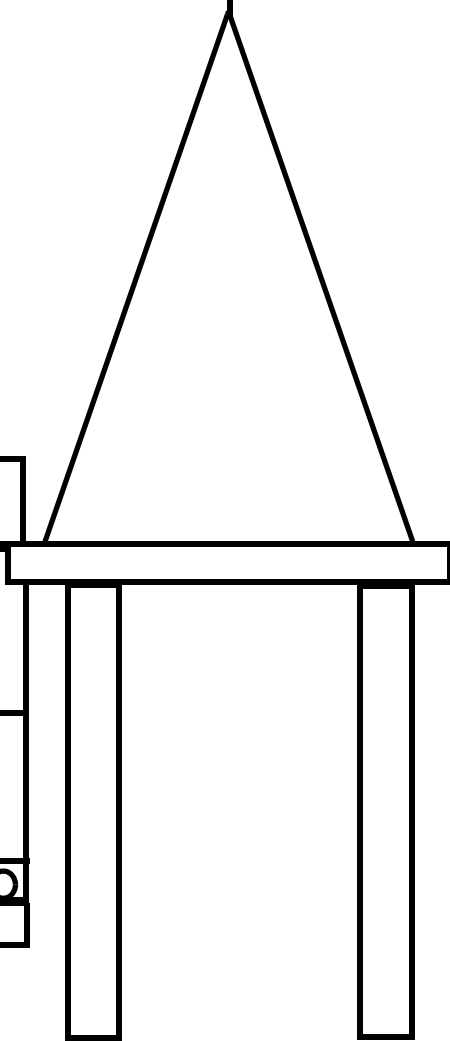
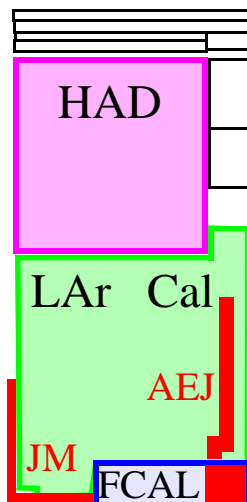
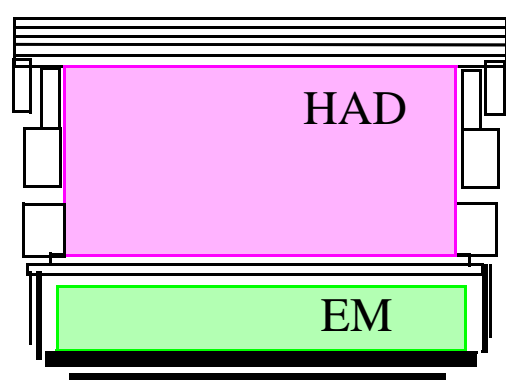

ACCESS

Rails

61

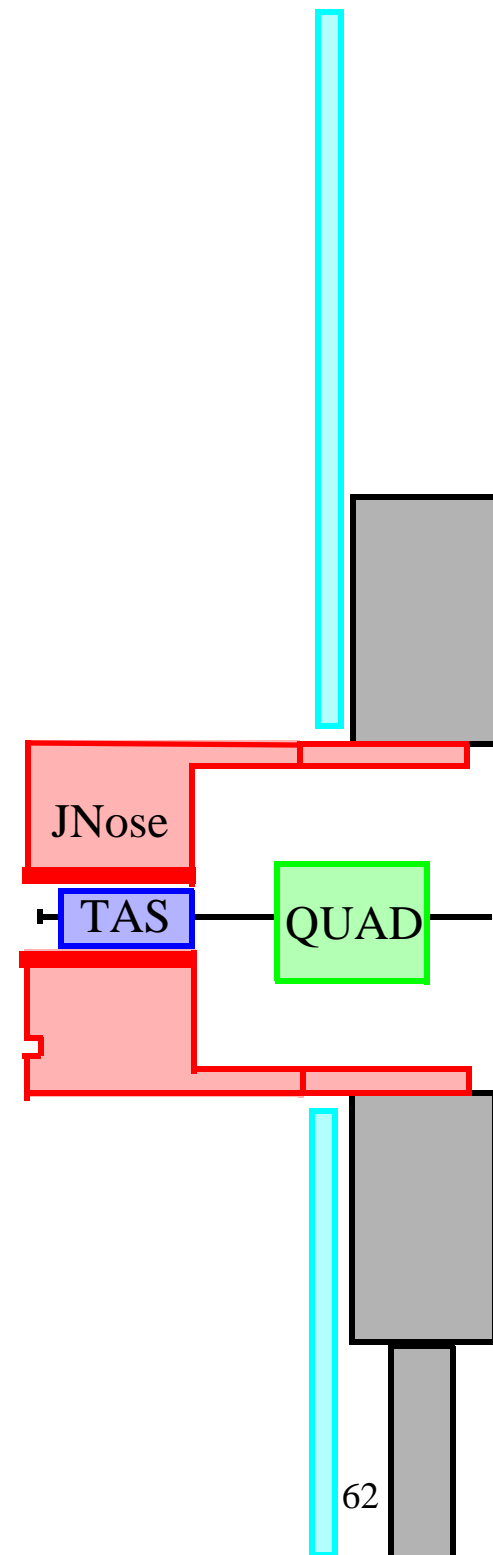
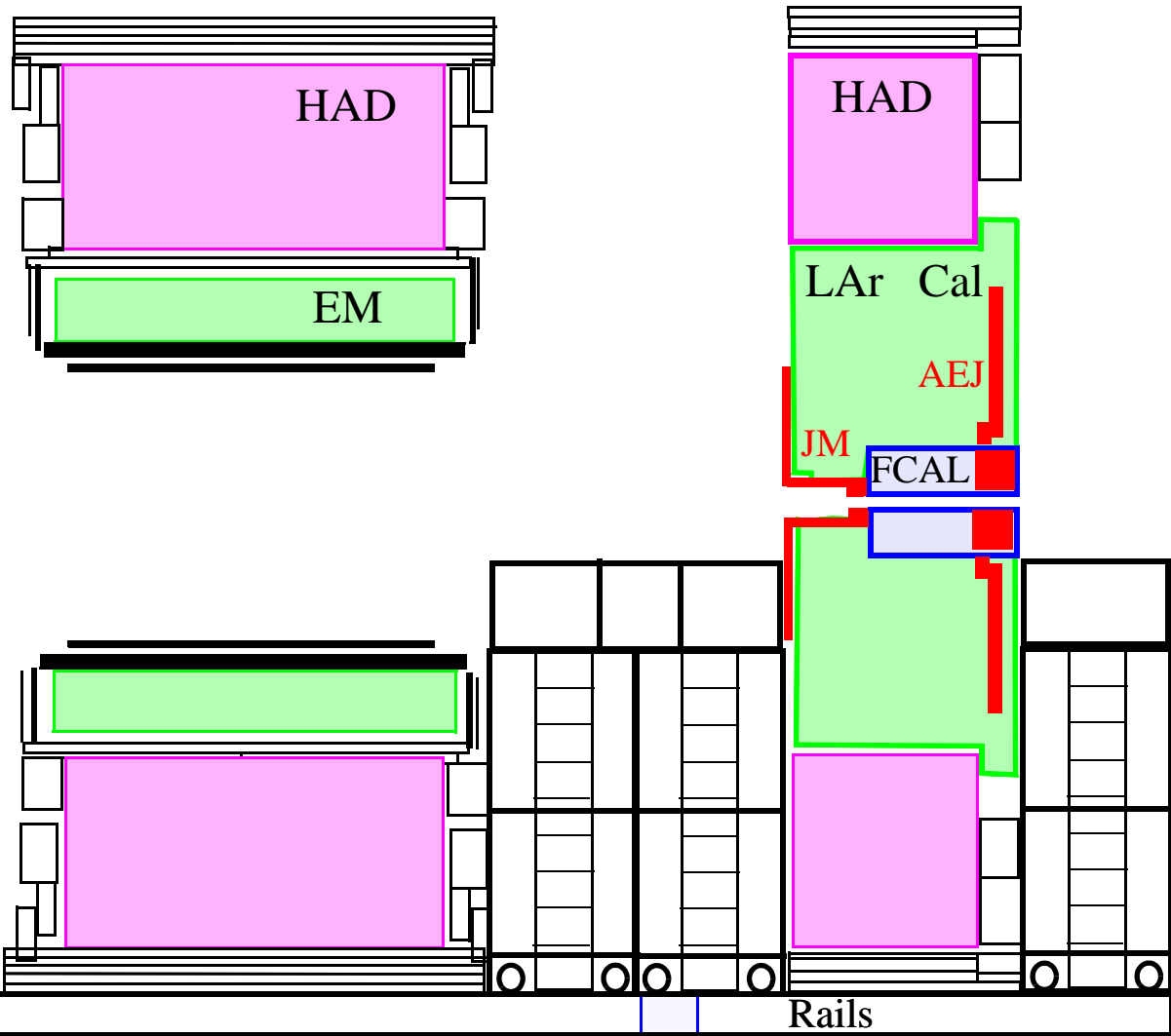

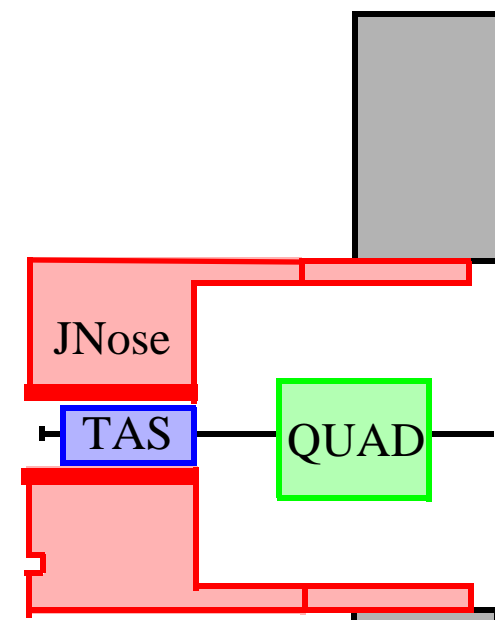
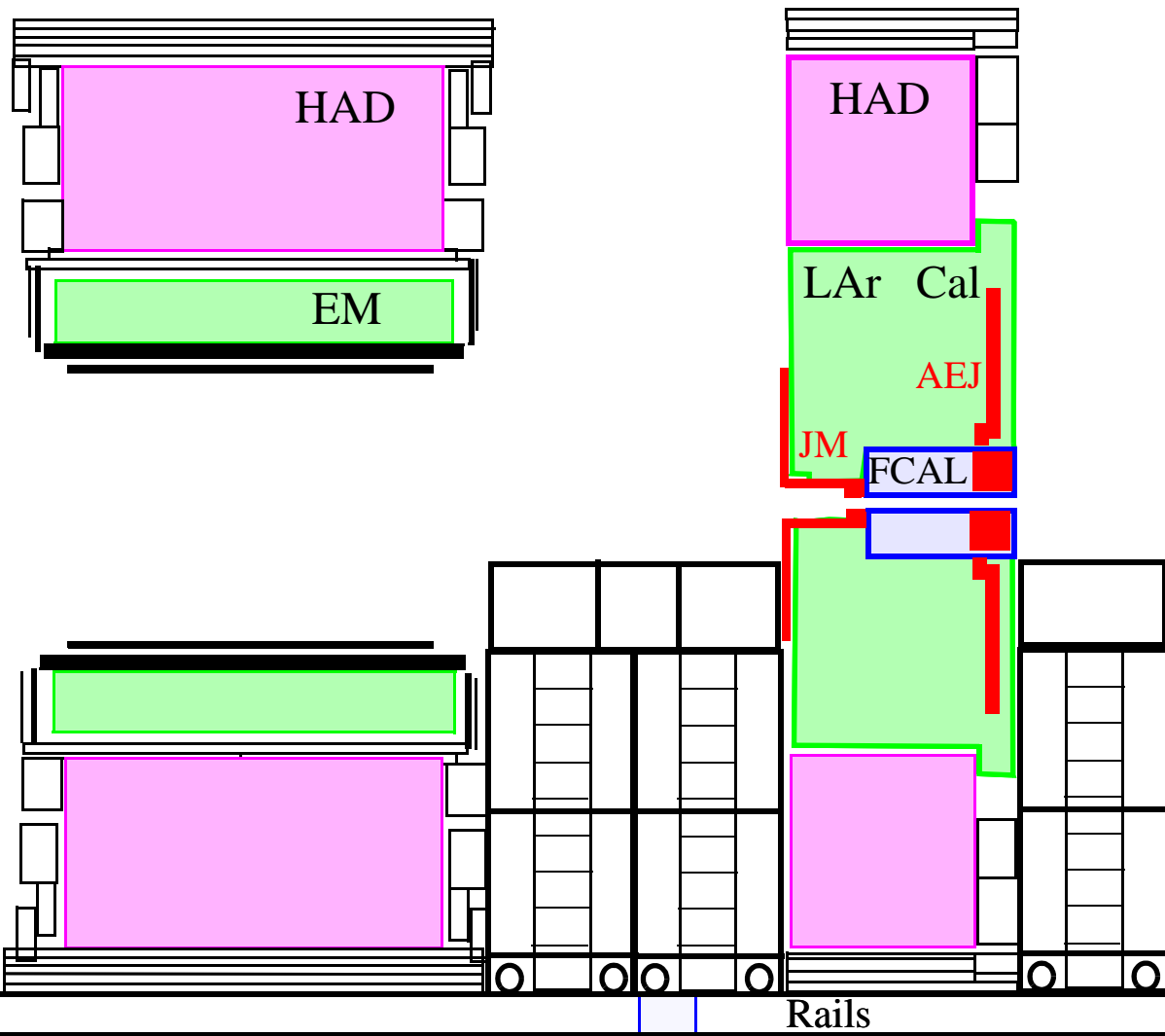

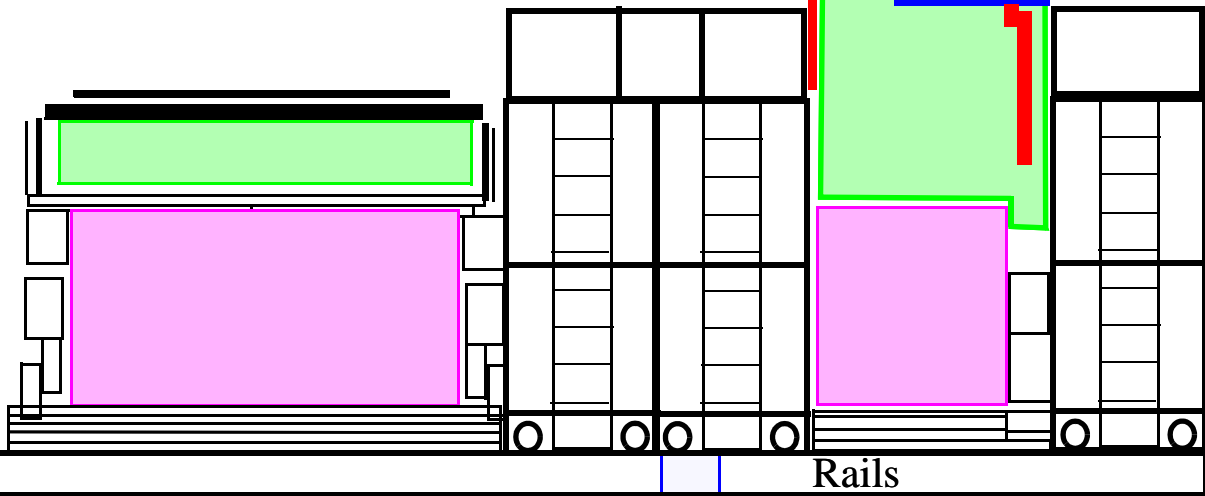
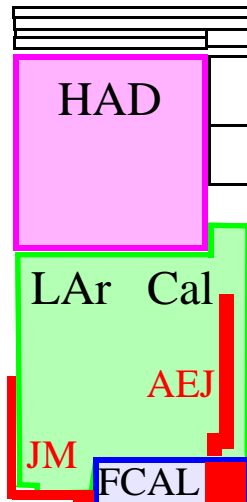
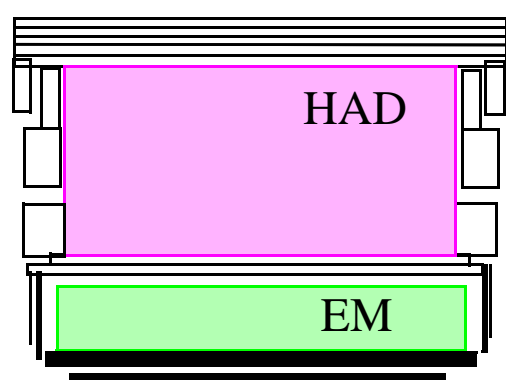

ACCESS

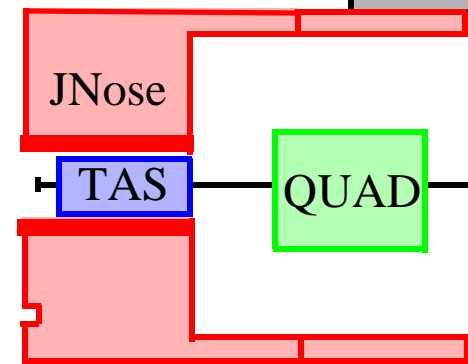

July 2006

The ID Barrel is installed from side A.

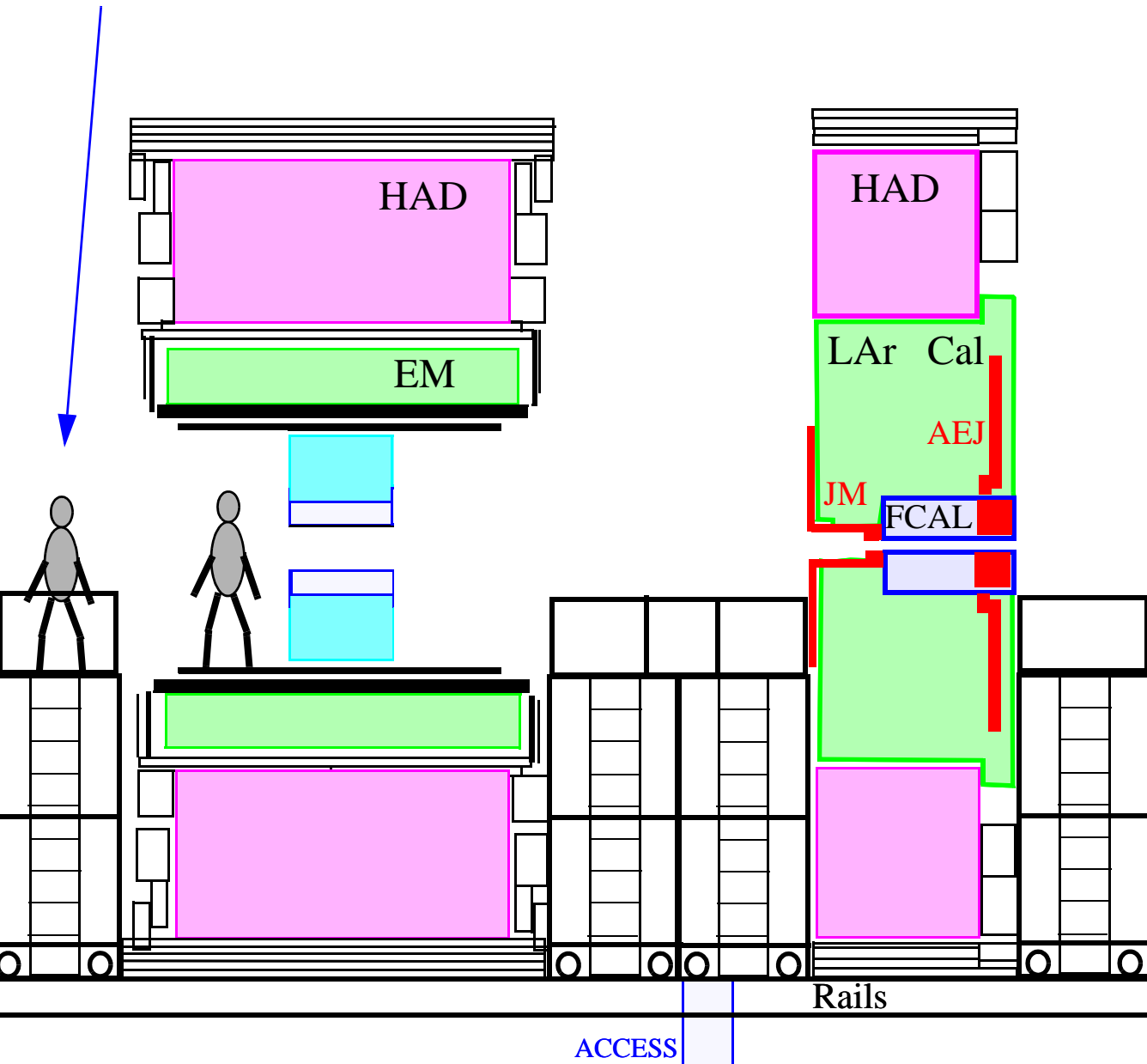

MDT

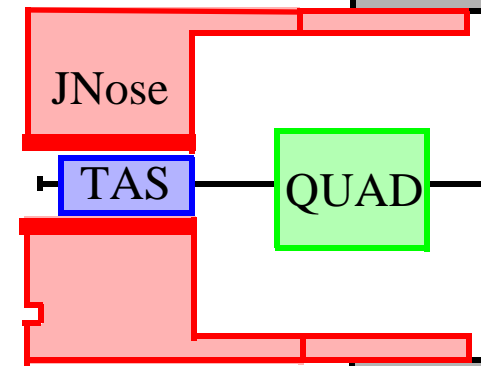

August 2006

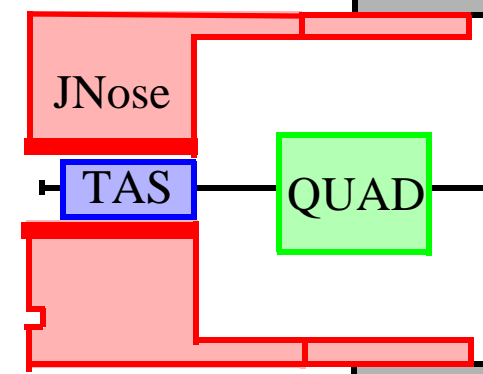
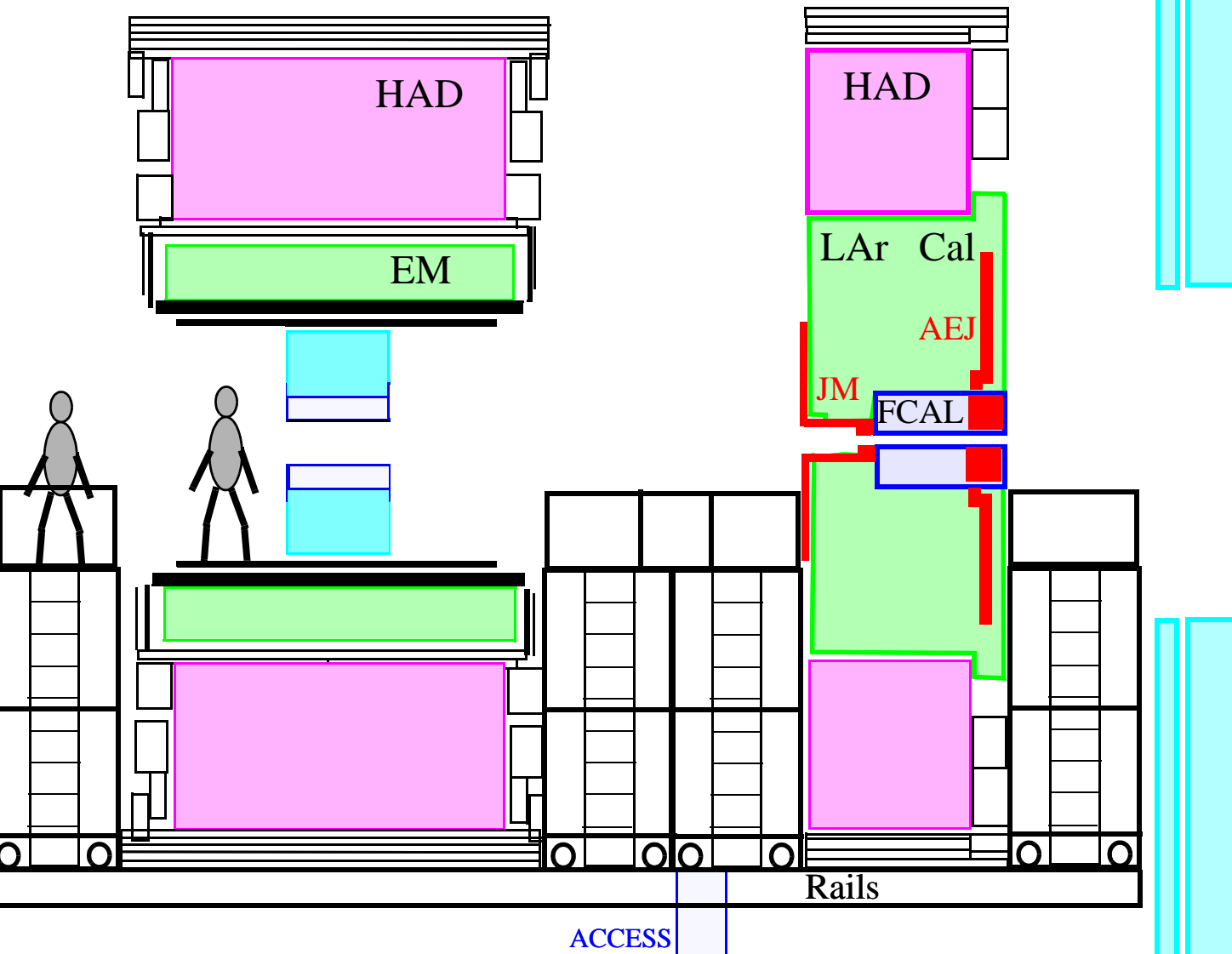

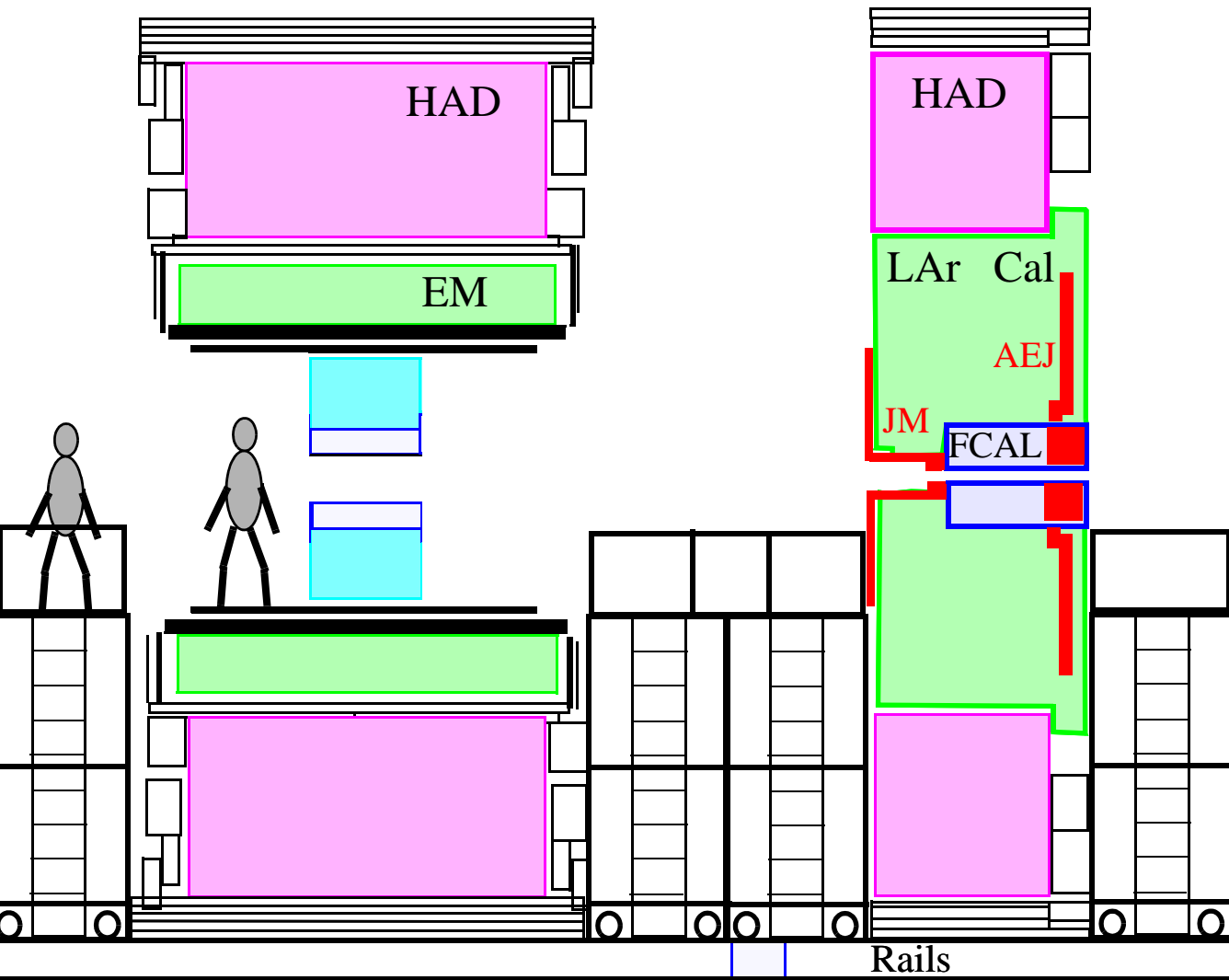

ACCESS

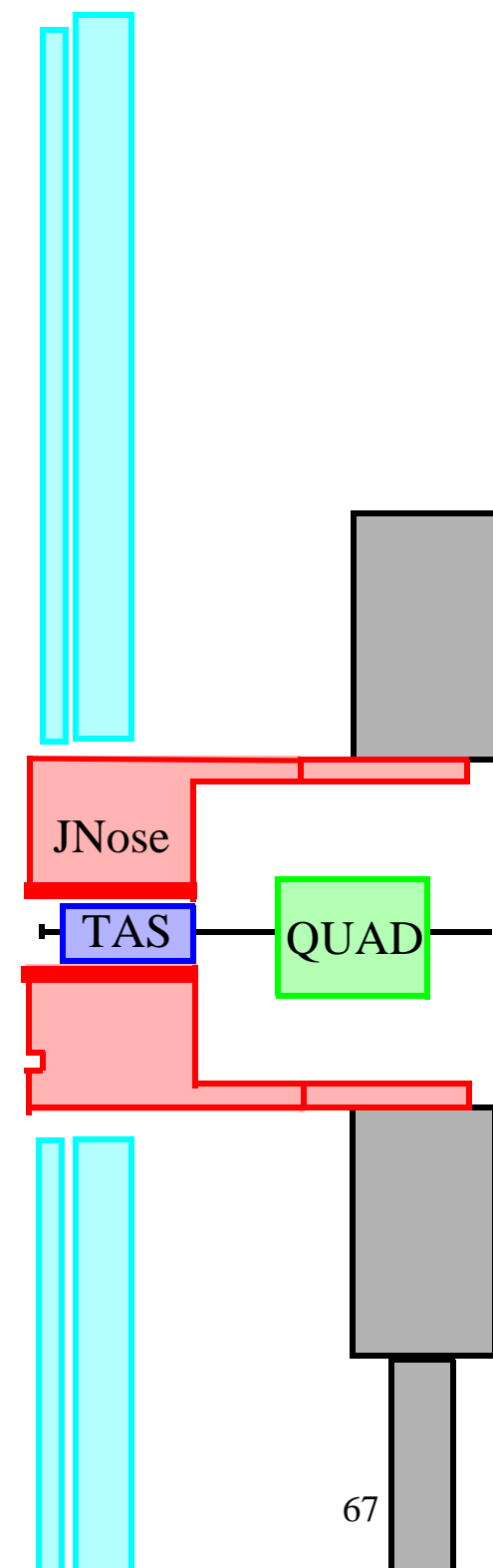

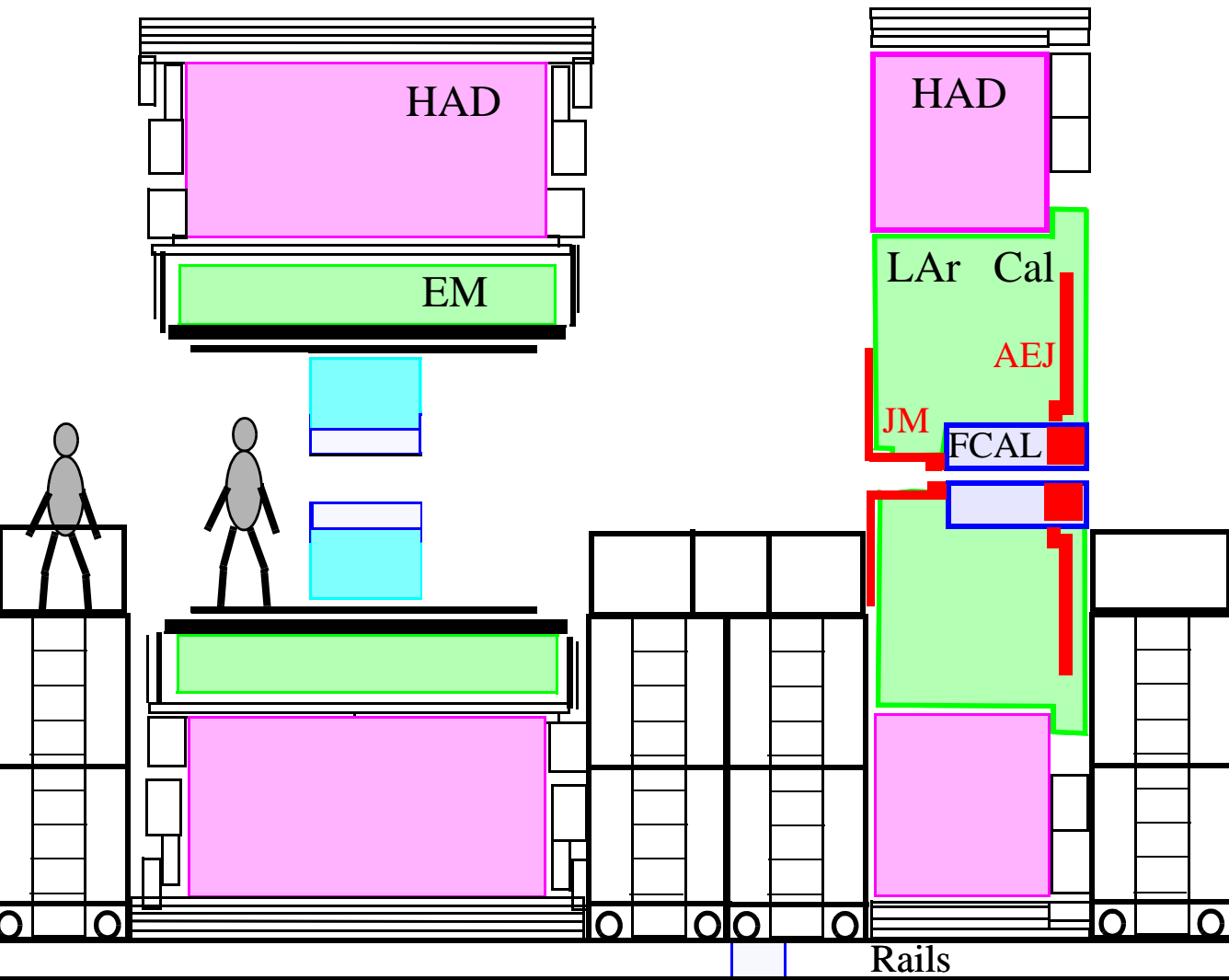

ACCESS

Rails

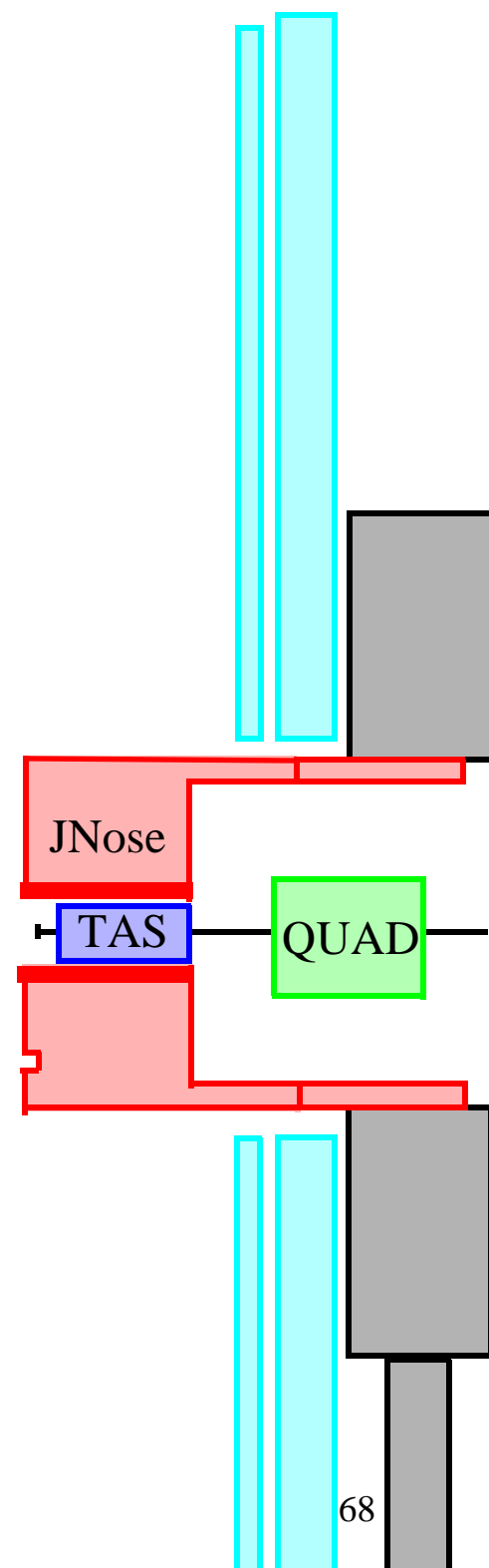

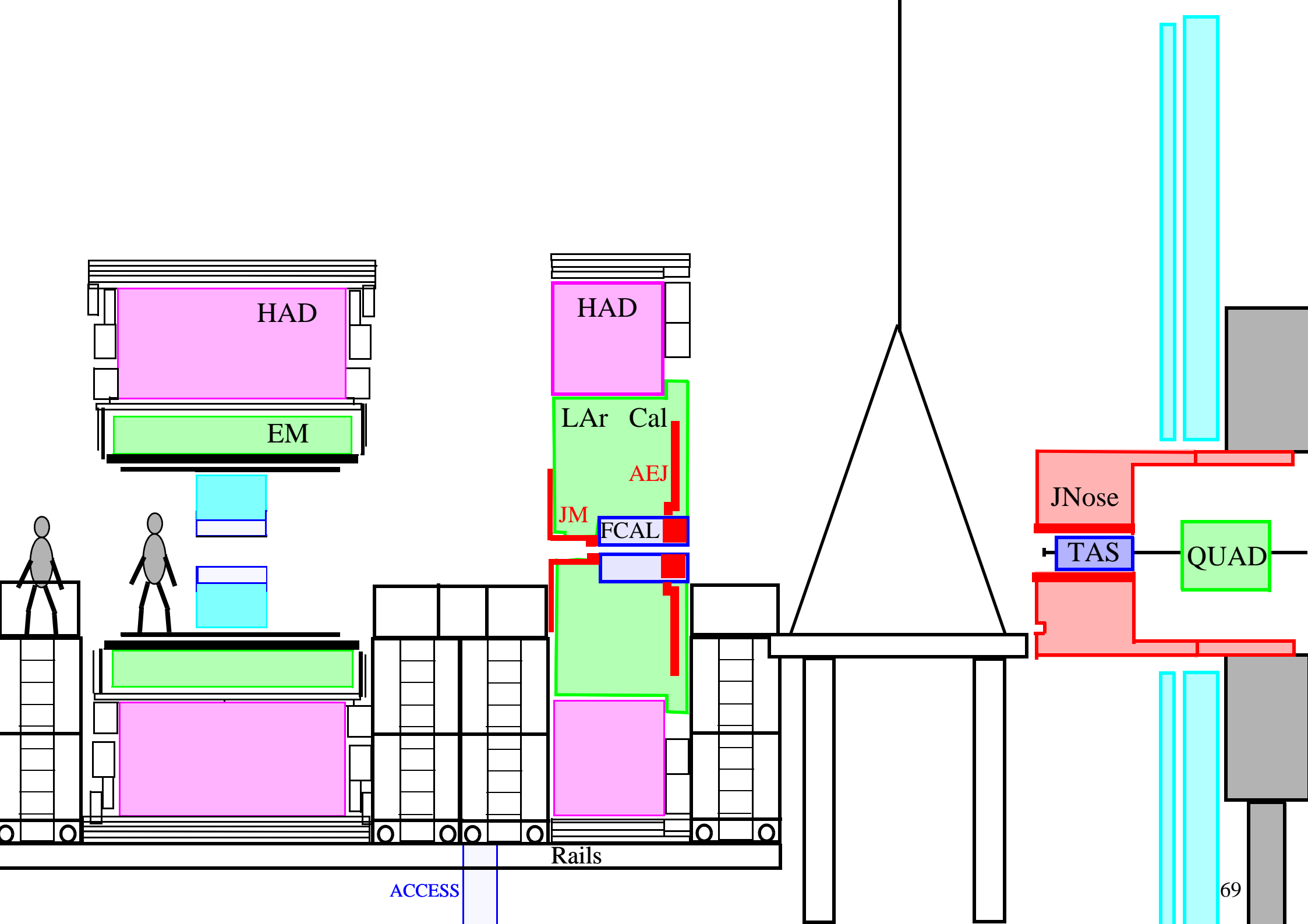

HAD

EM

HAD

LAr Cal

AEJ

JM

FCAL

JNose

TAS

QUAD

Rails

ACCESS

September 2006

Only small scaffolding is available during the toroid installation on side A.

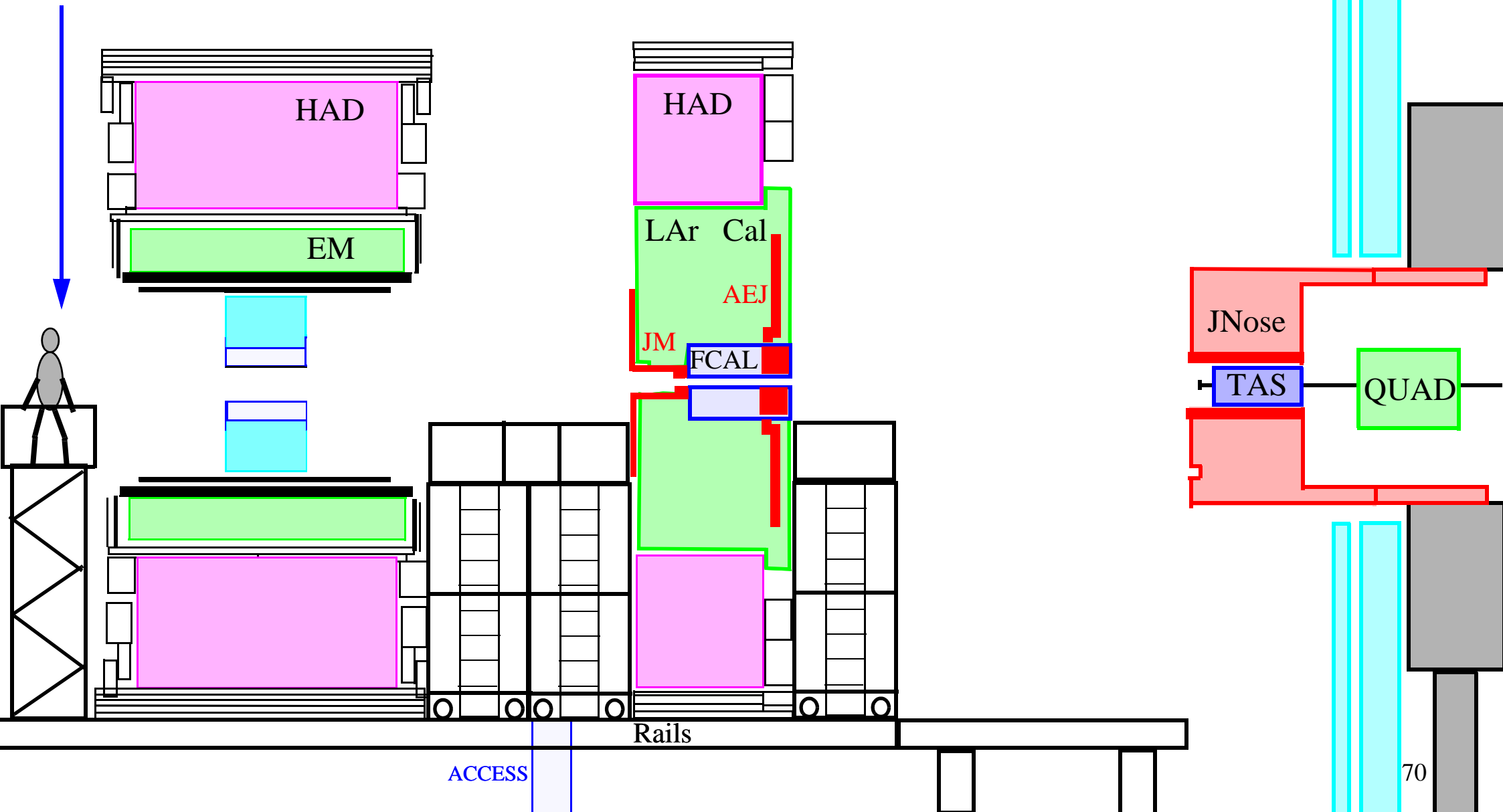

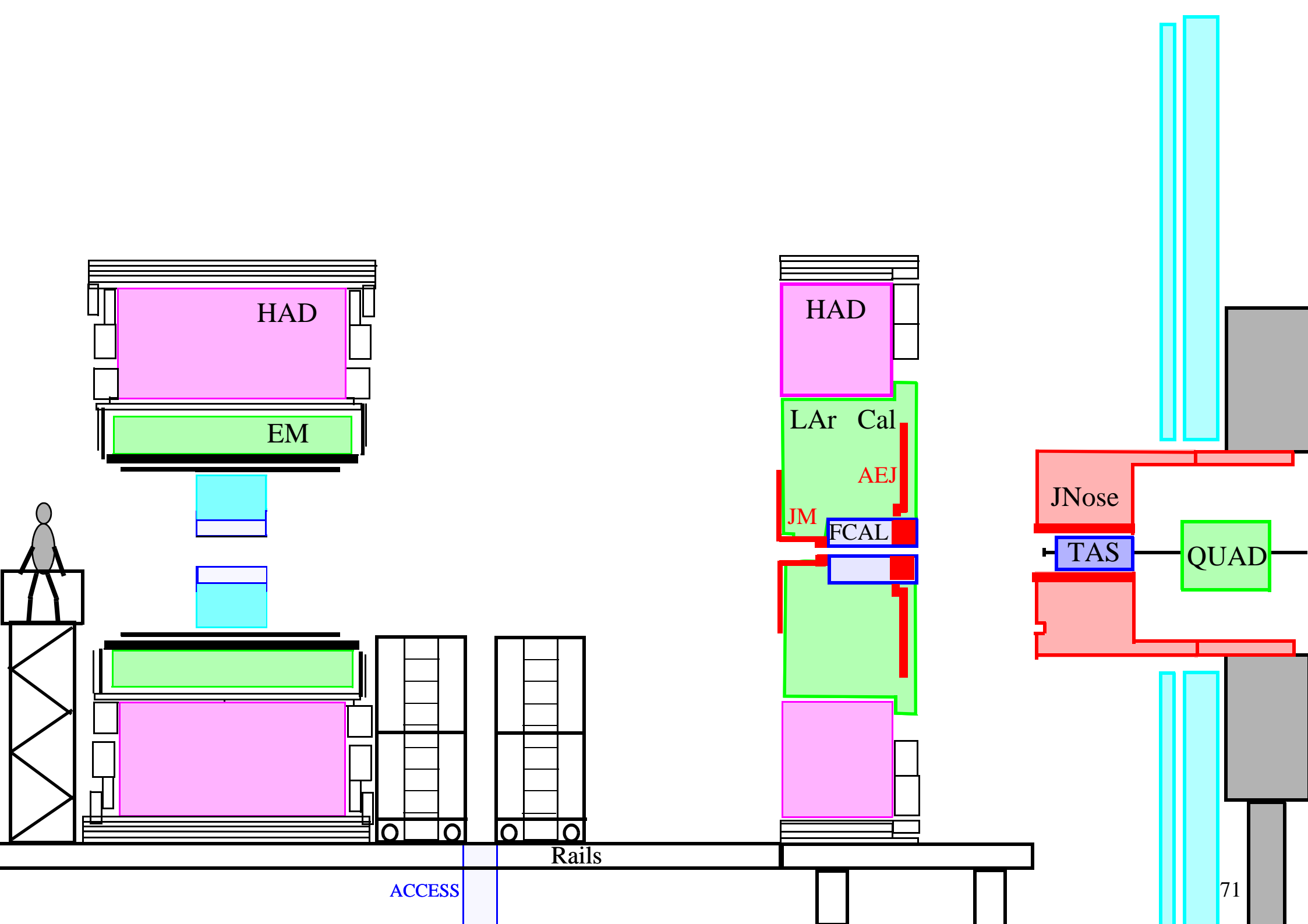

ACCESS

Rails

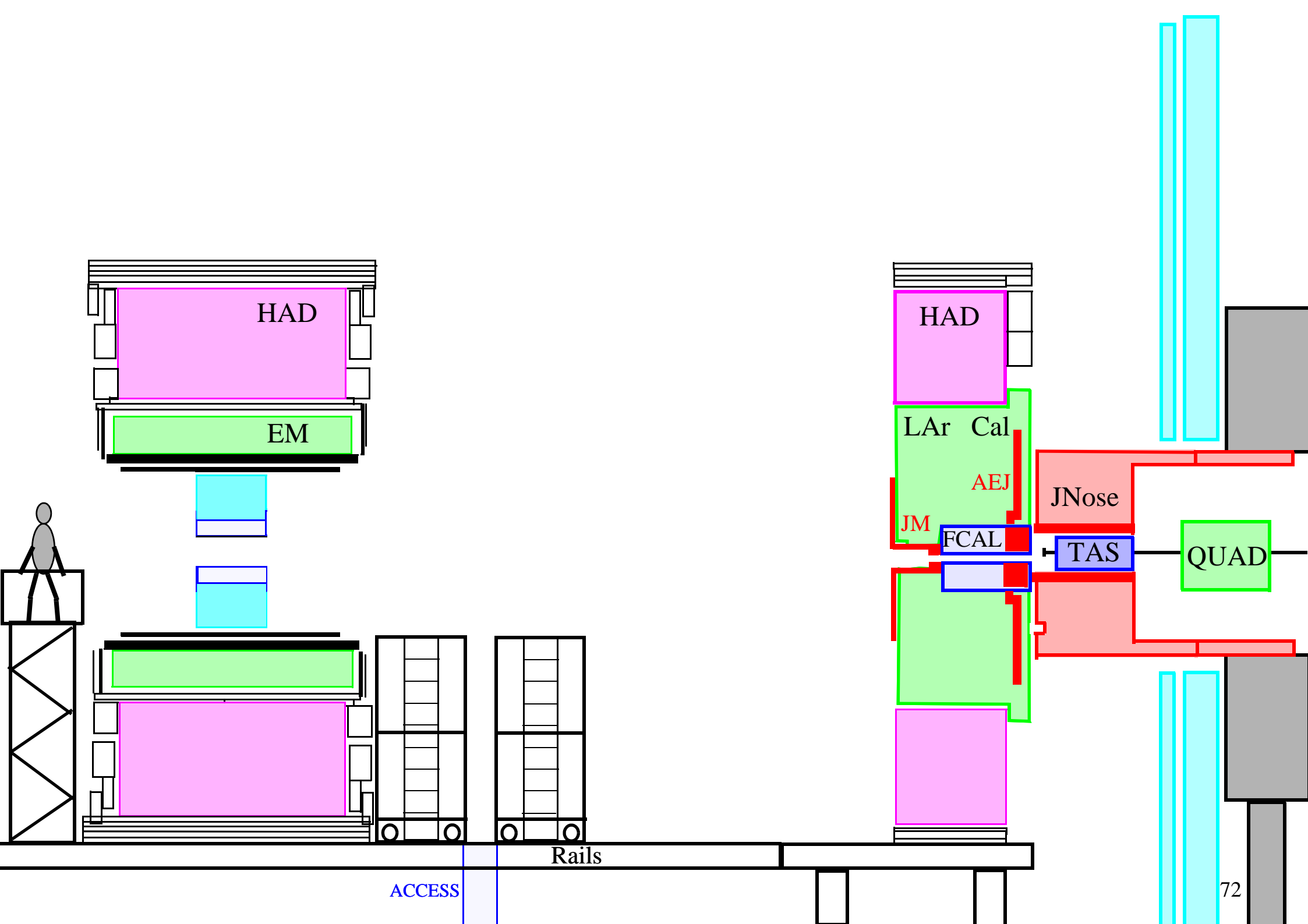

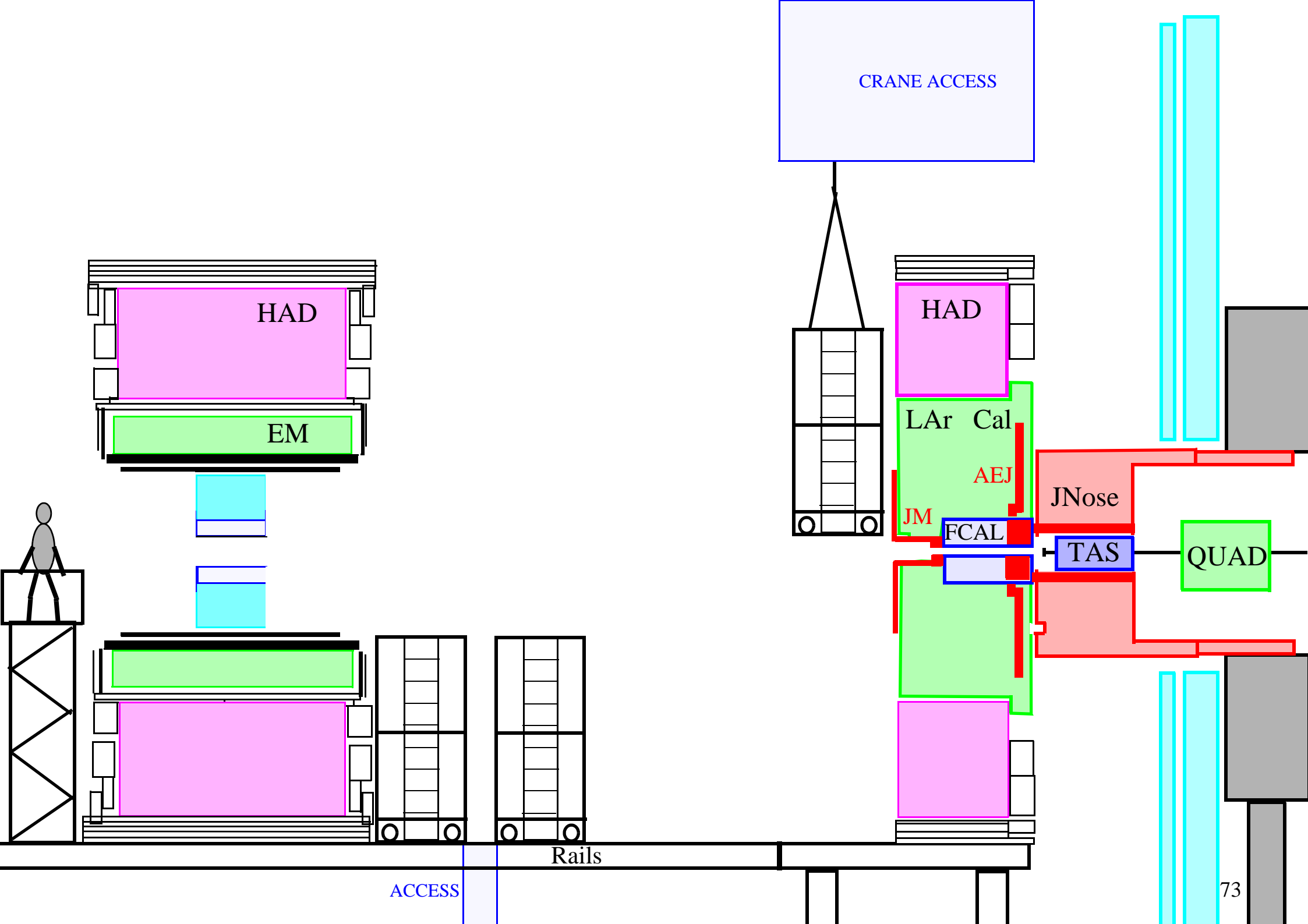

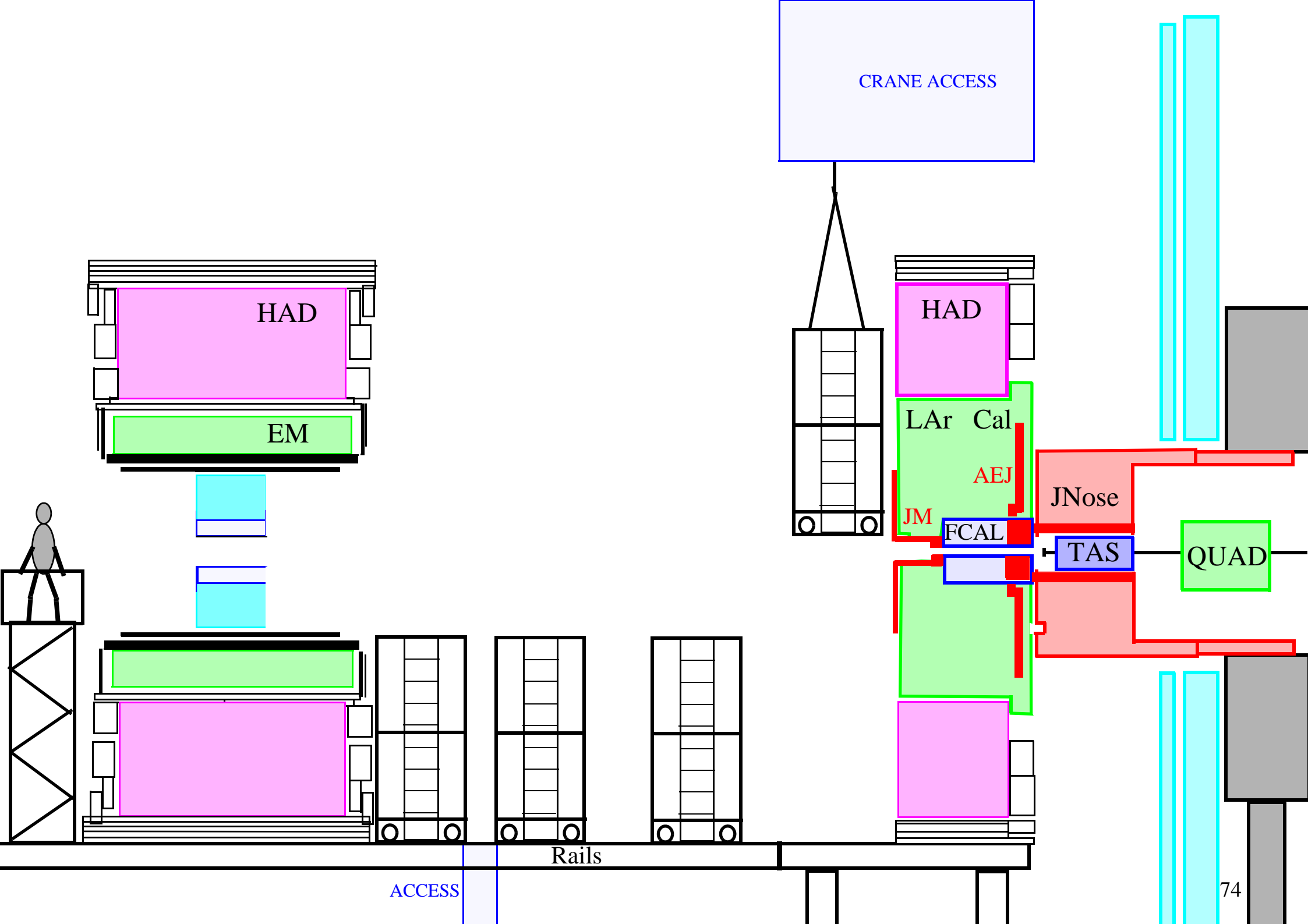

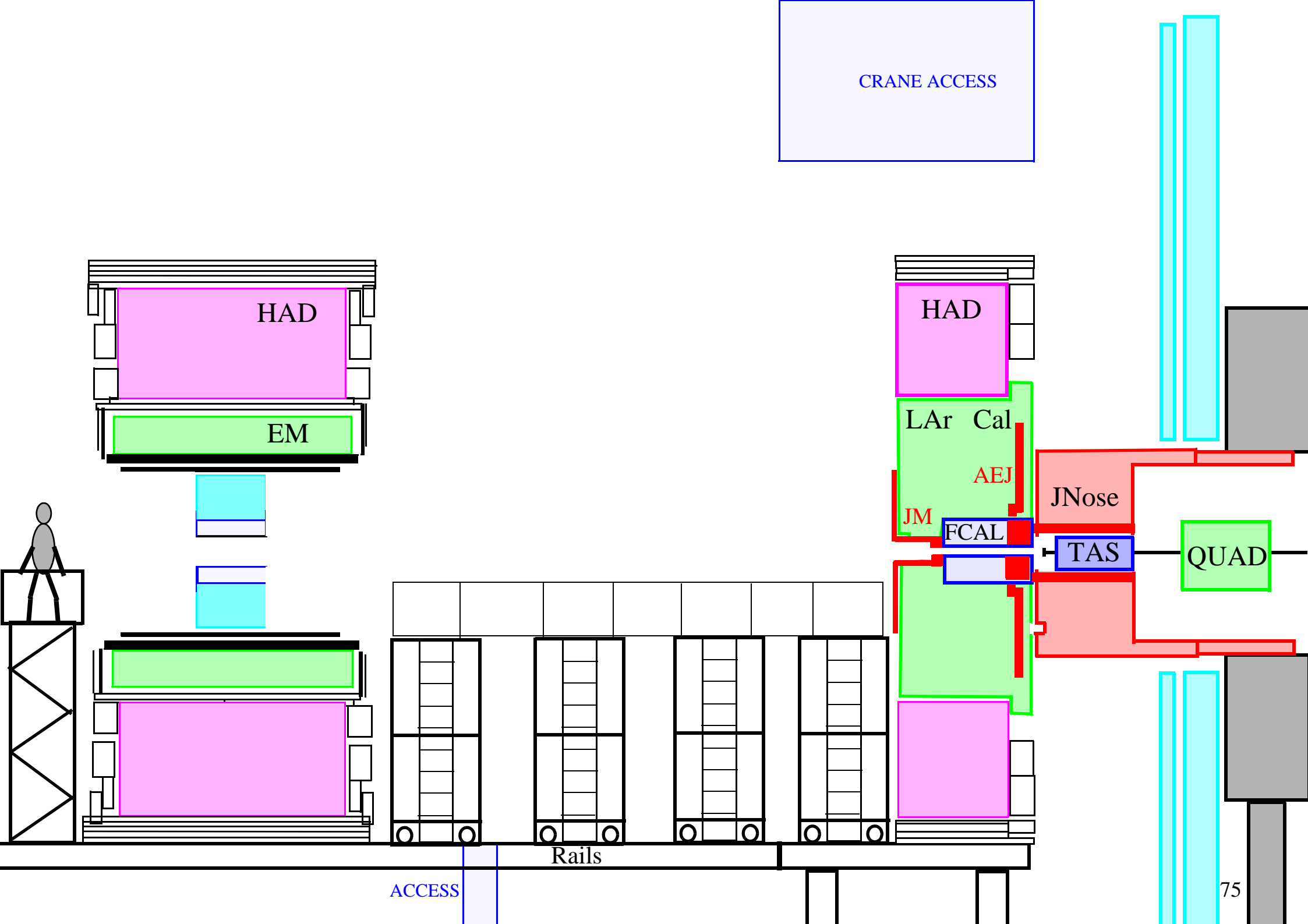

CRANE ACCESS

HAD

EM

HAD

LAr Cal

AEJ

JM

FCAL

JNose

TAS

QUAD

RAILS

ACCESS

75

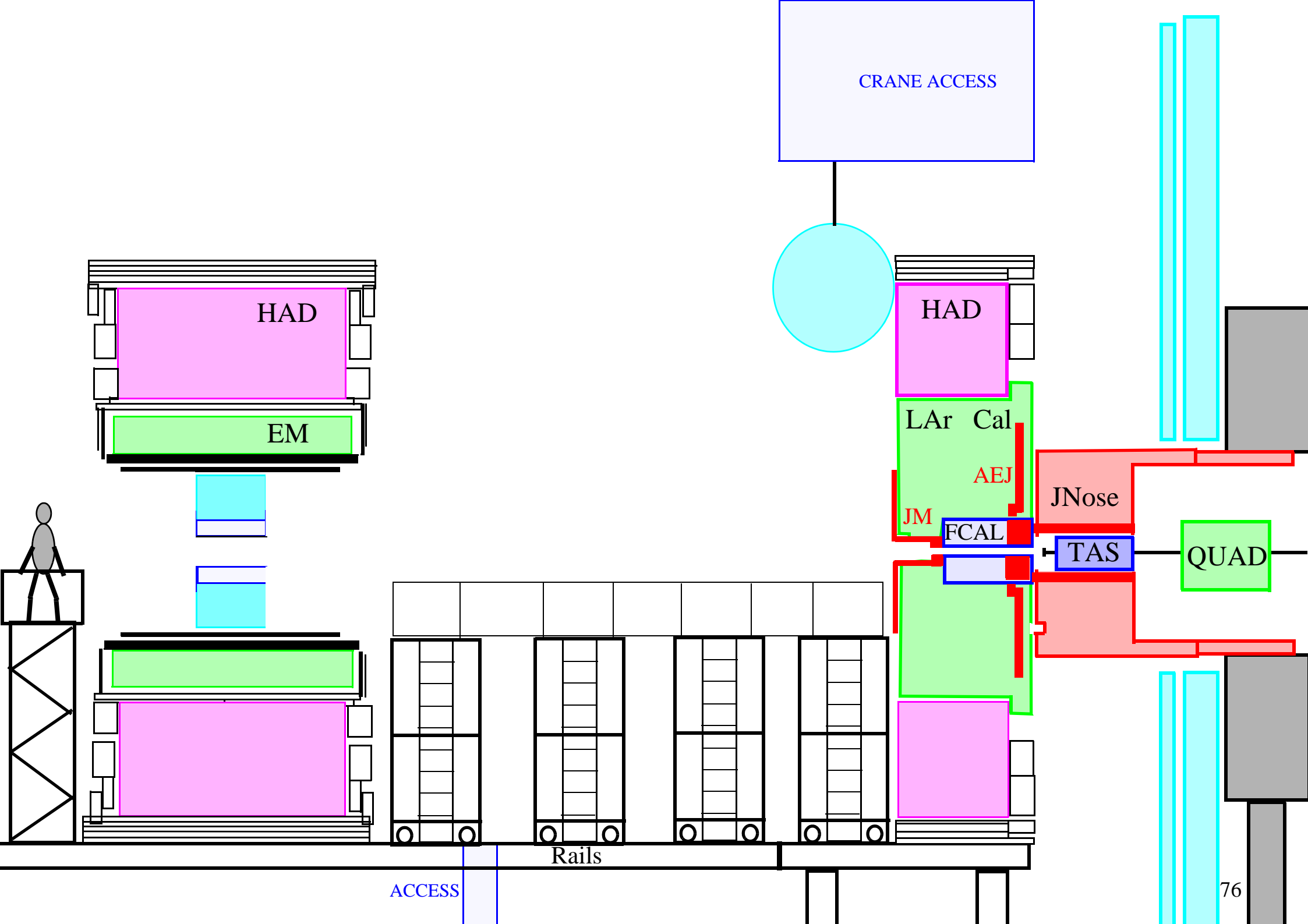

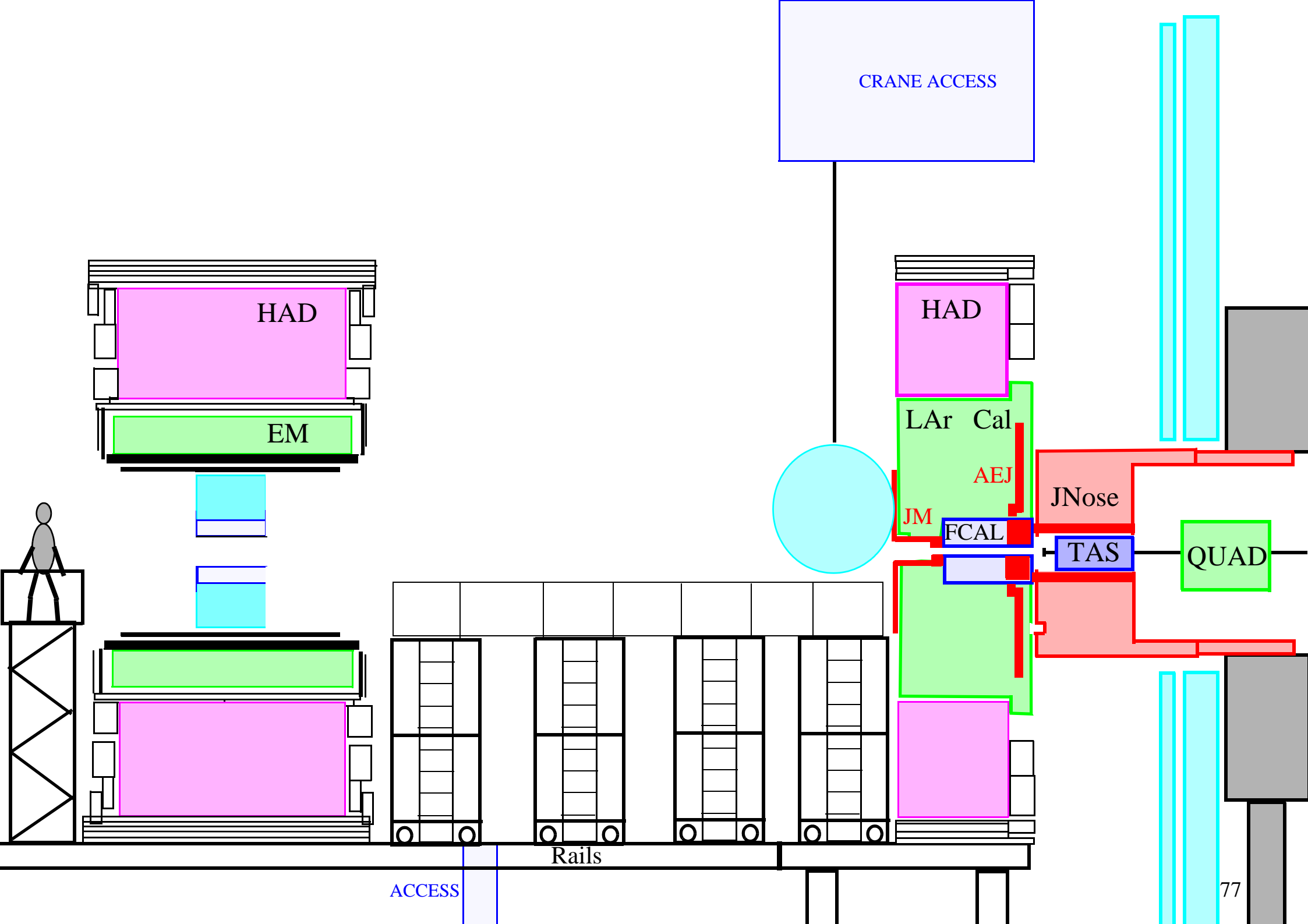

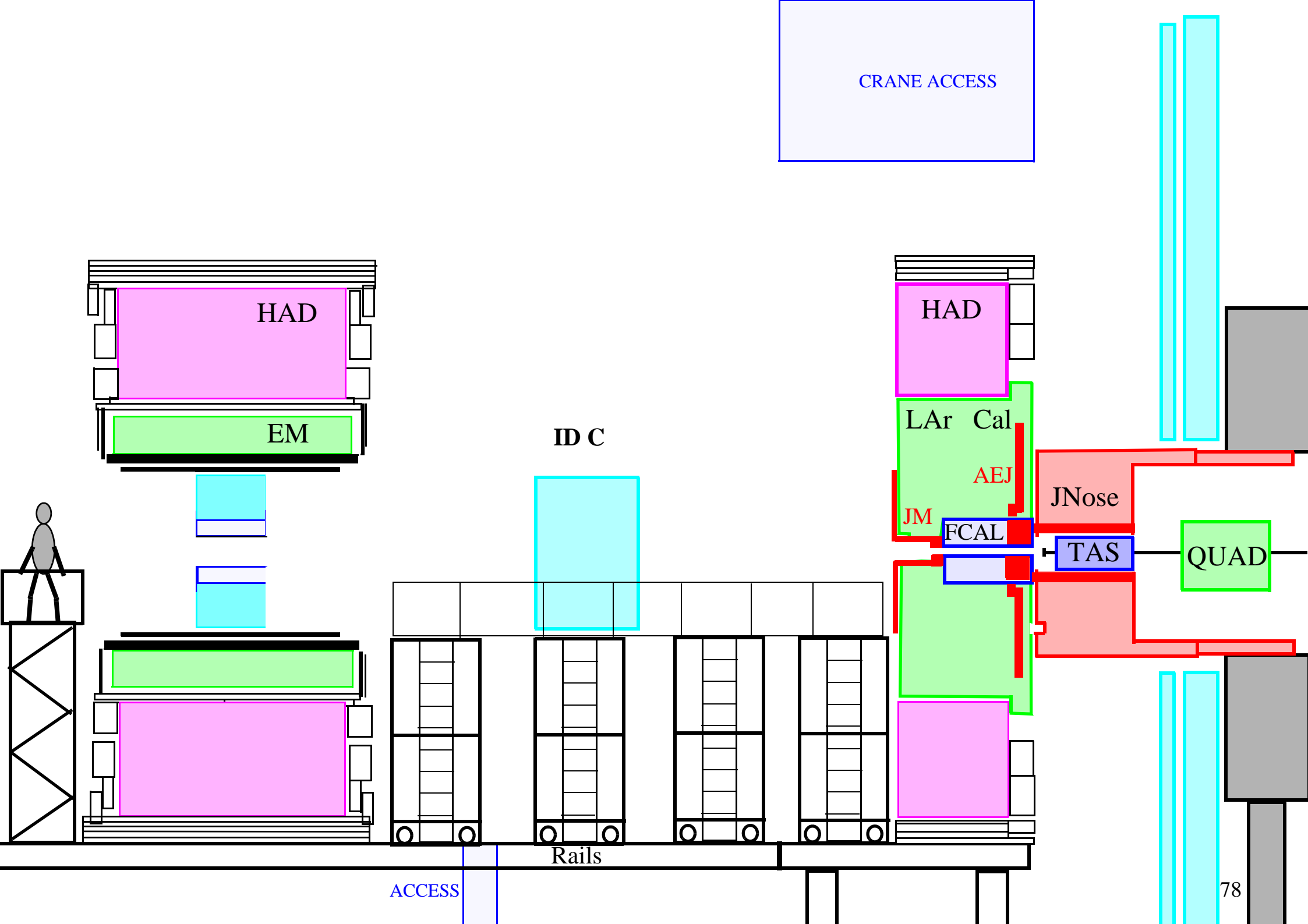

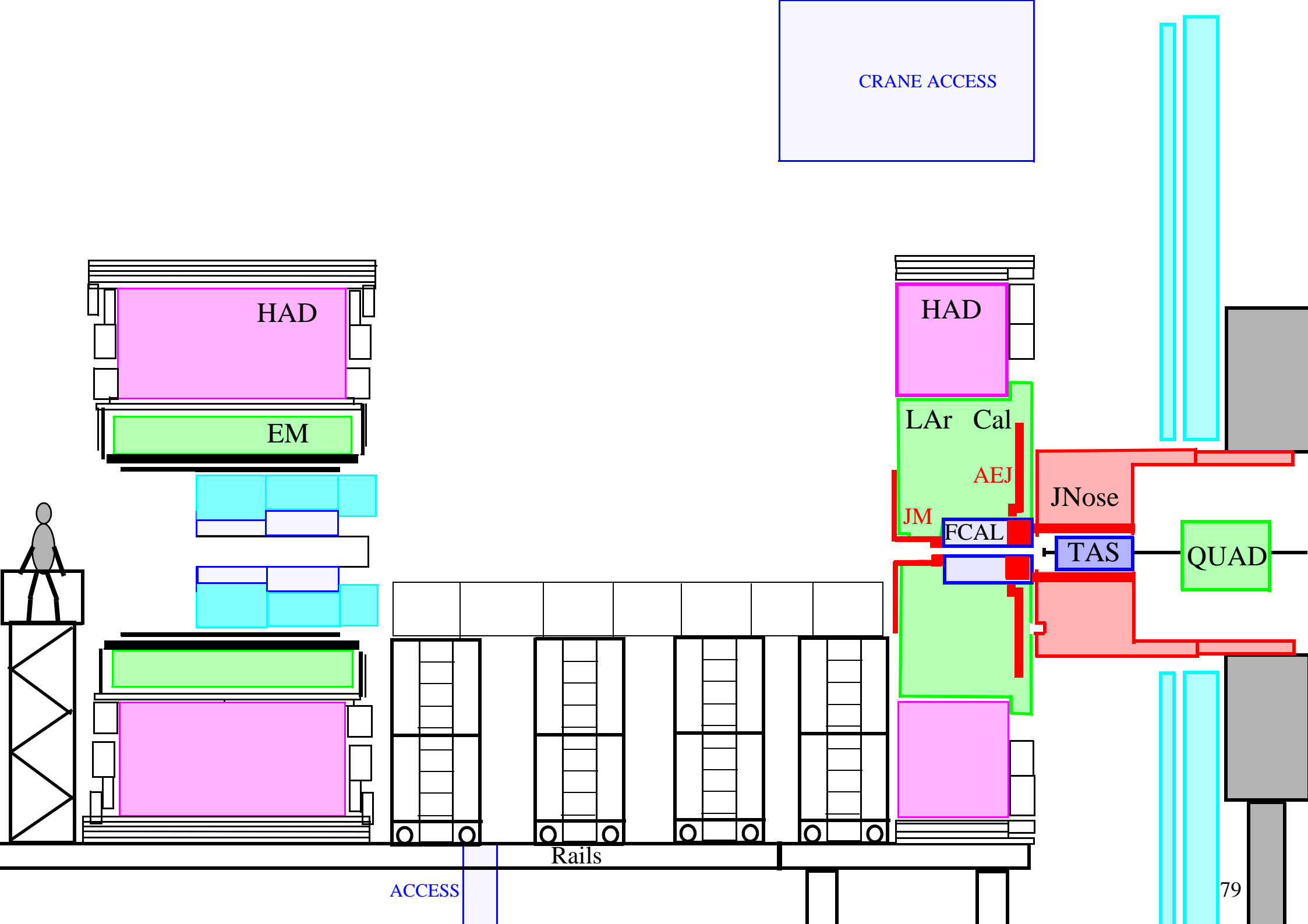

CRANE ACCESS

HAD

EM

HAD

LAr Cal

AEJ

JM

FCAL

JNose

TAS

QUAD

Rails

ACCESS

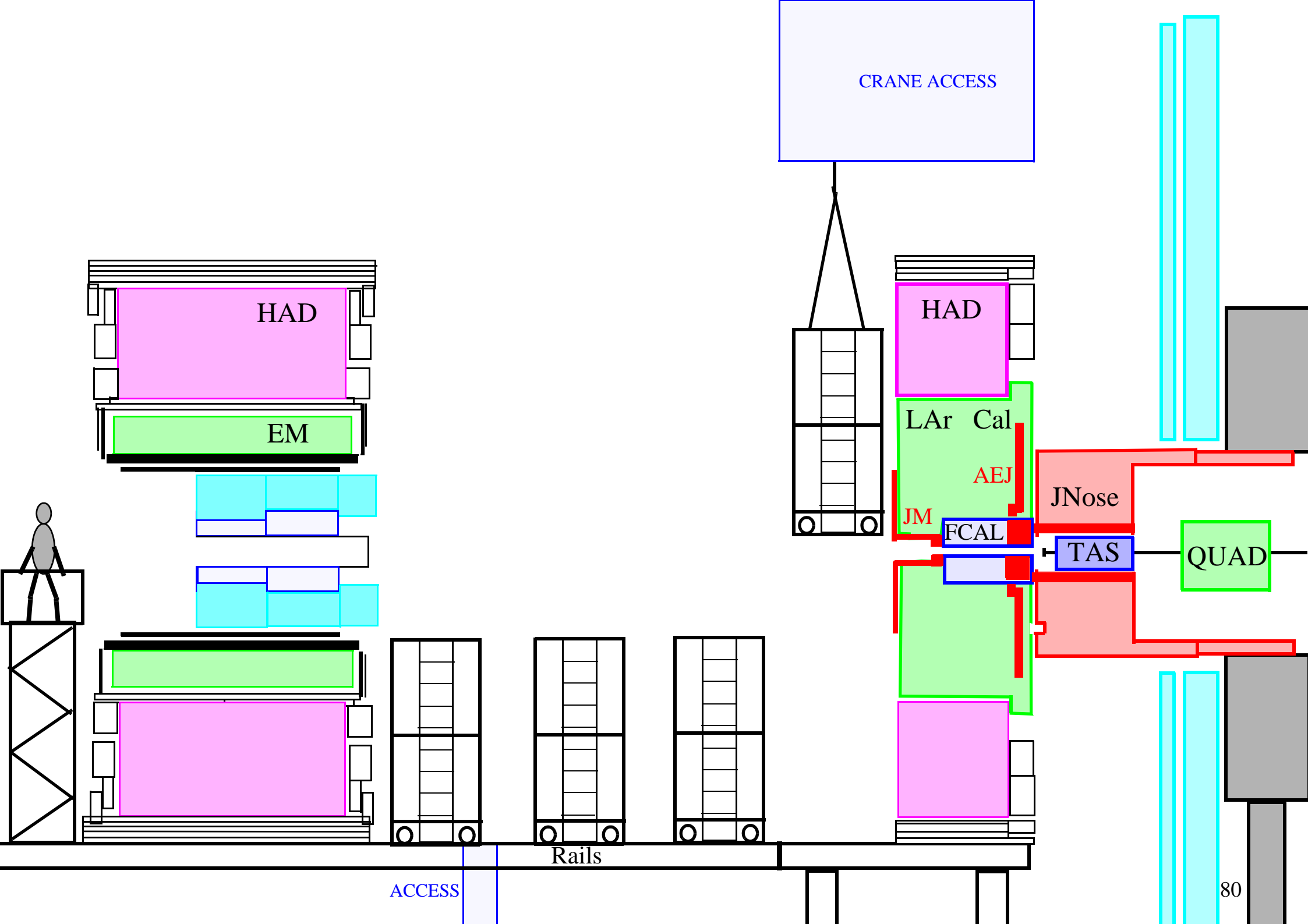

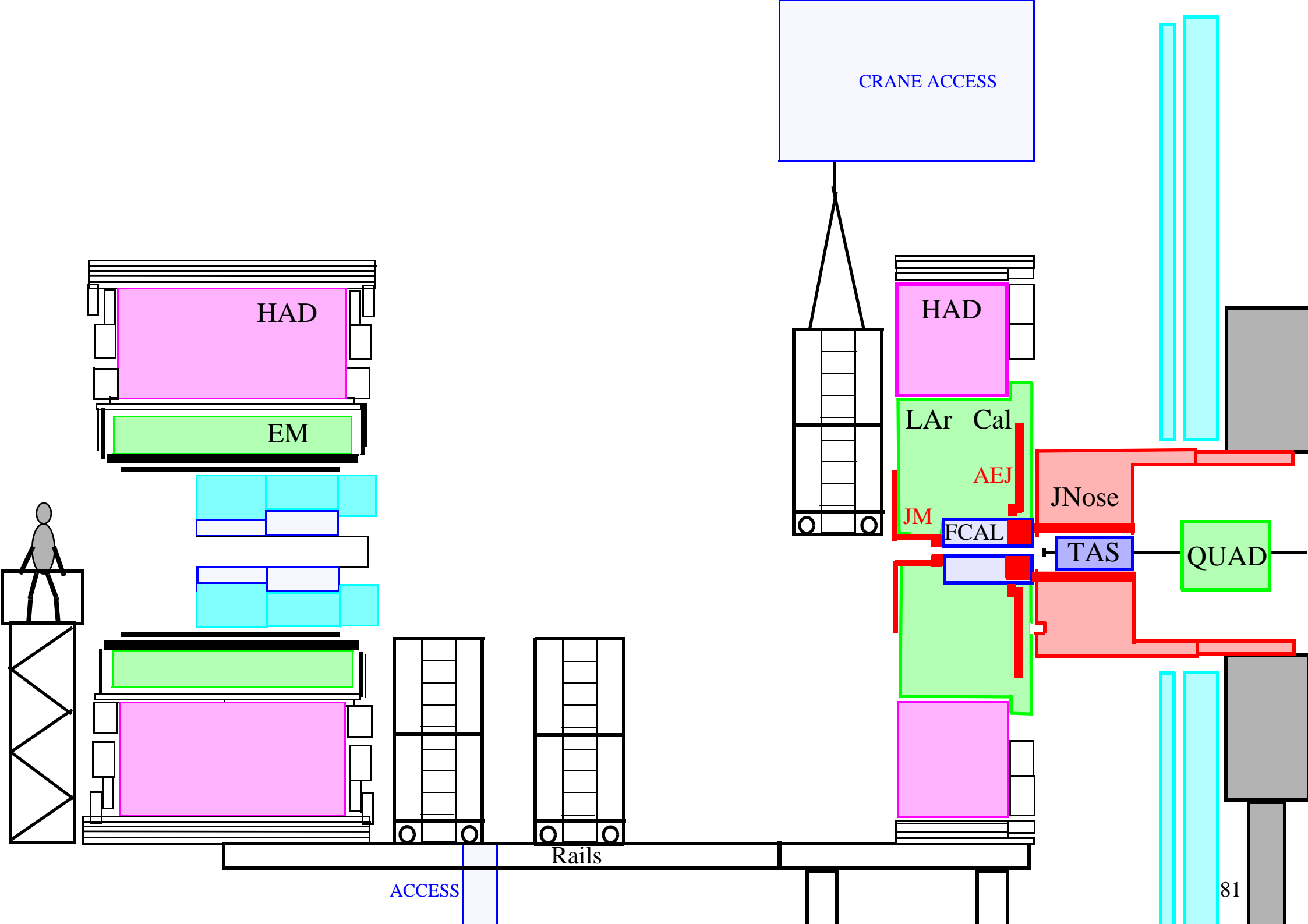

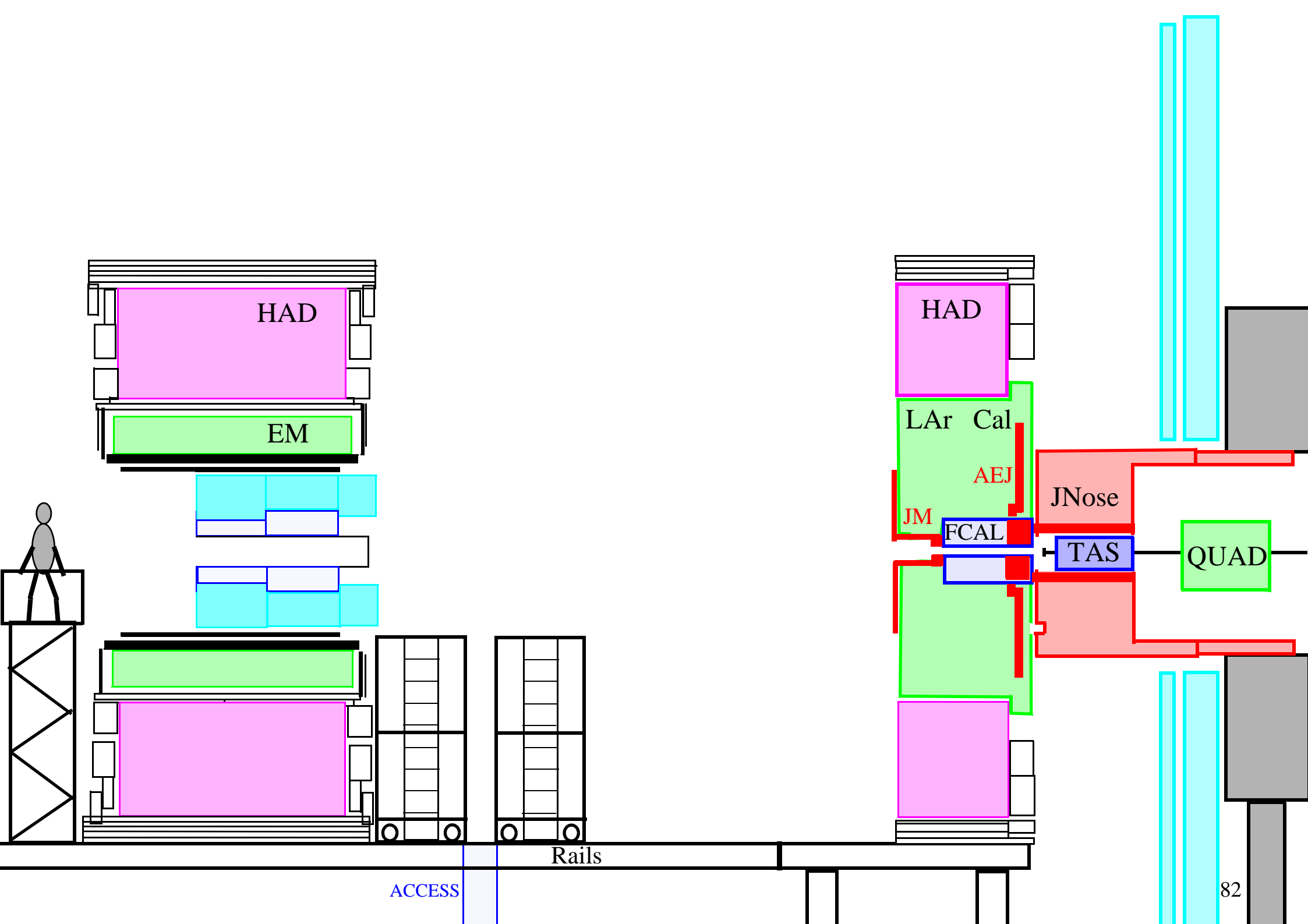

HAD

EM

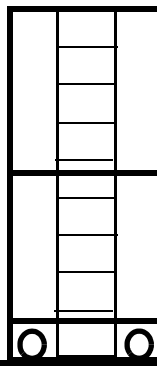
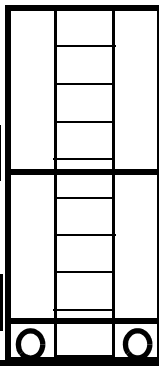

Rails

ACCESS

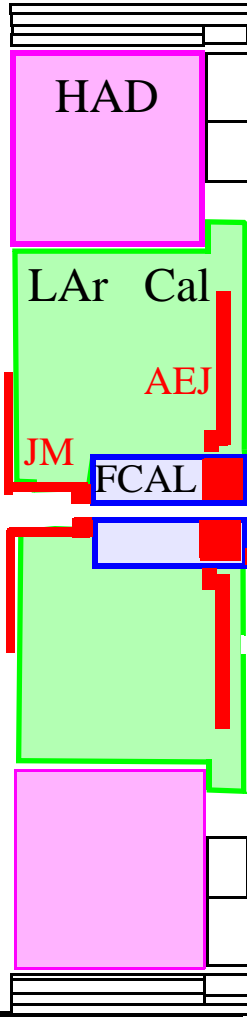

HAD

LAr Cal

JM

AEJ

FCAL

JNose

TAS

QUAD

82

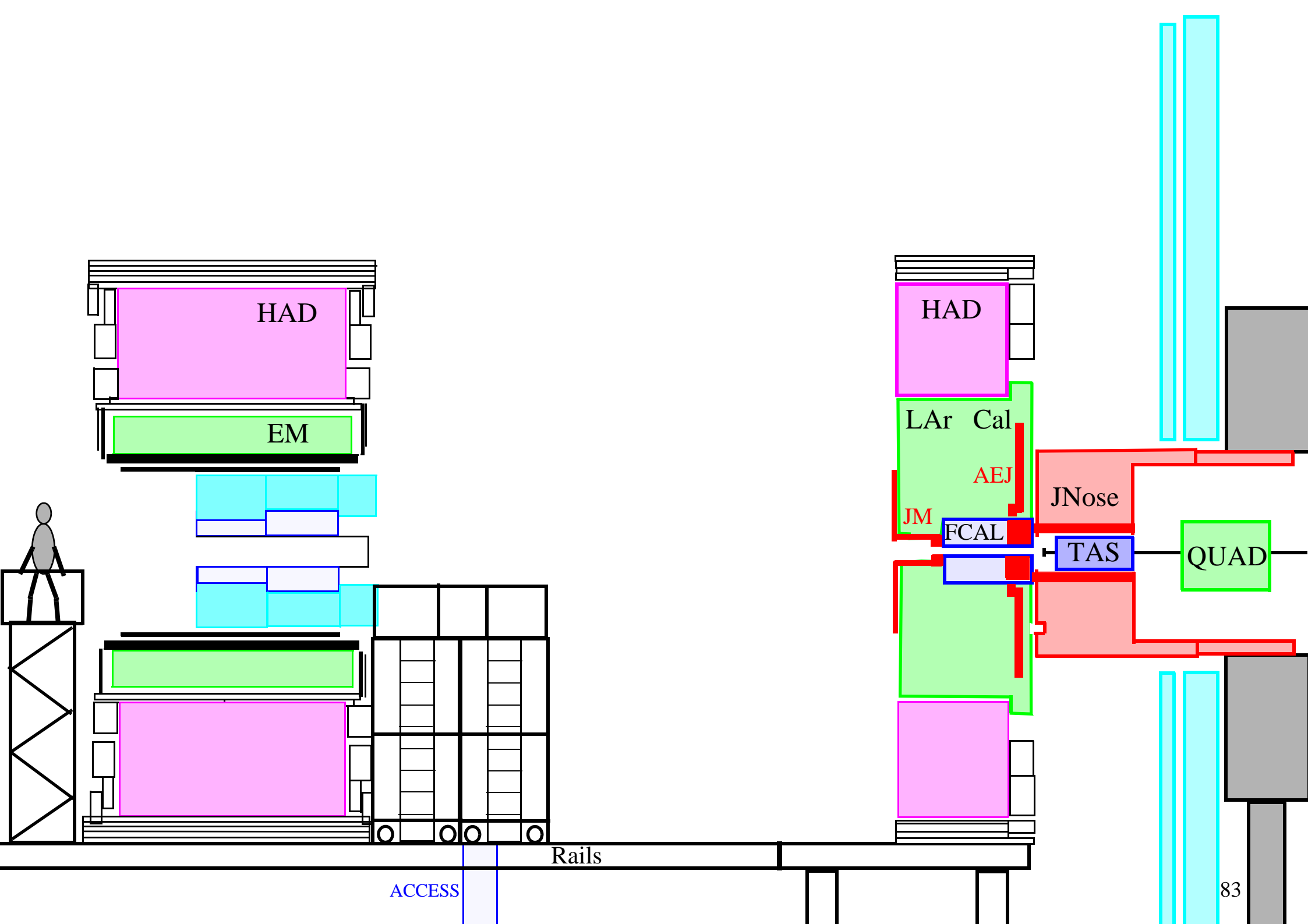

HAD

EM



HAD

LAr Cal

AEJ

JM

FCAL

JNose

TAS

QUAD

Rails

ACCESS

83

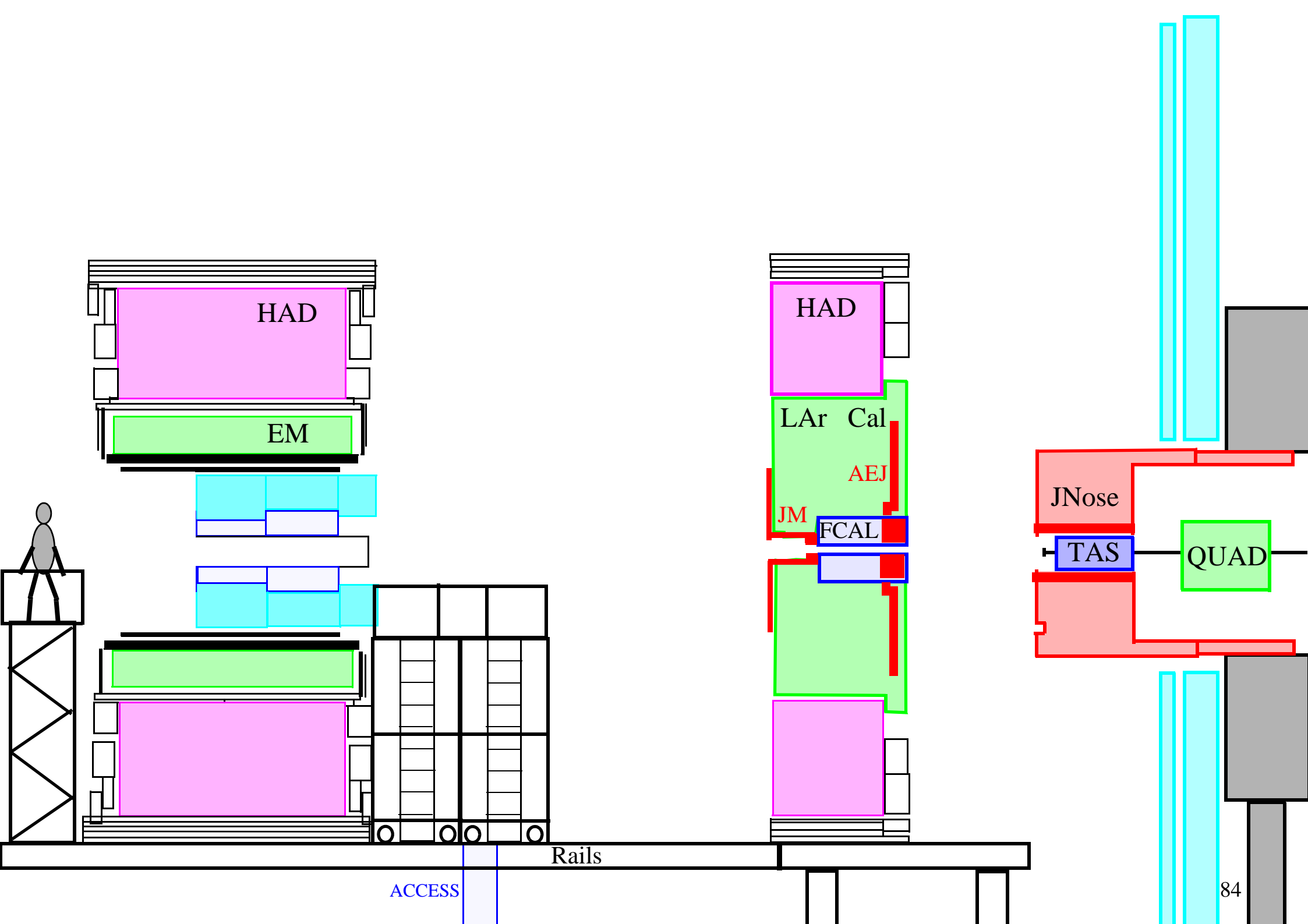

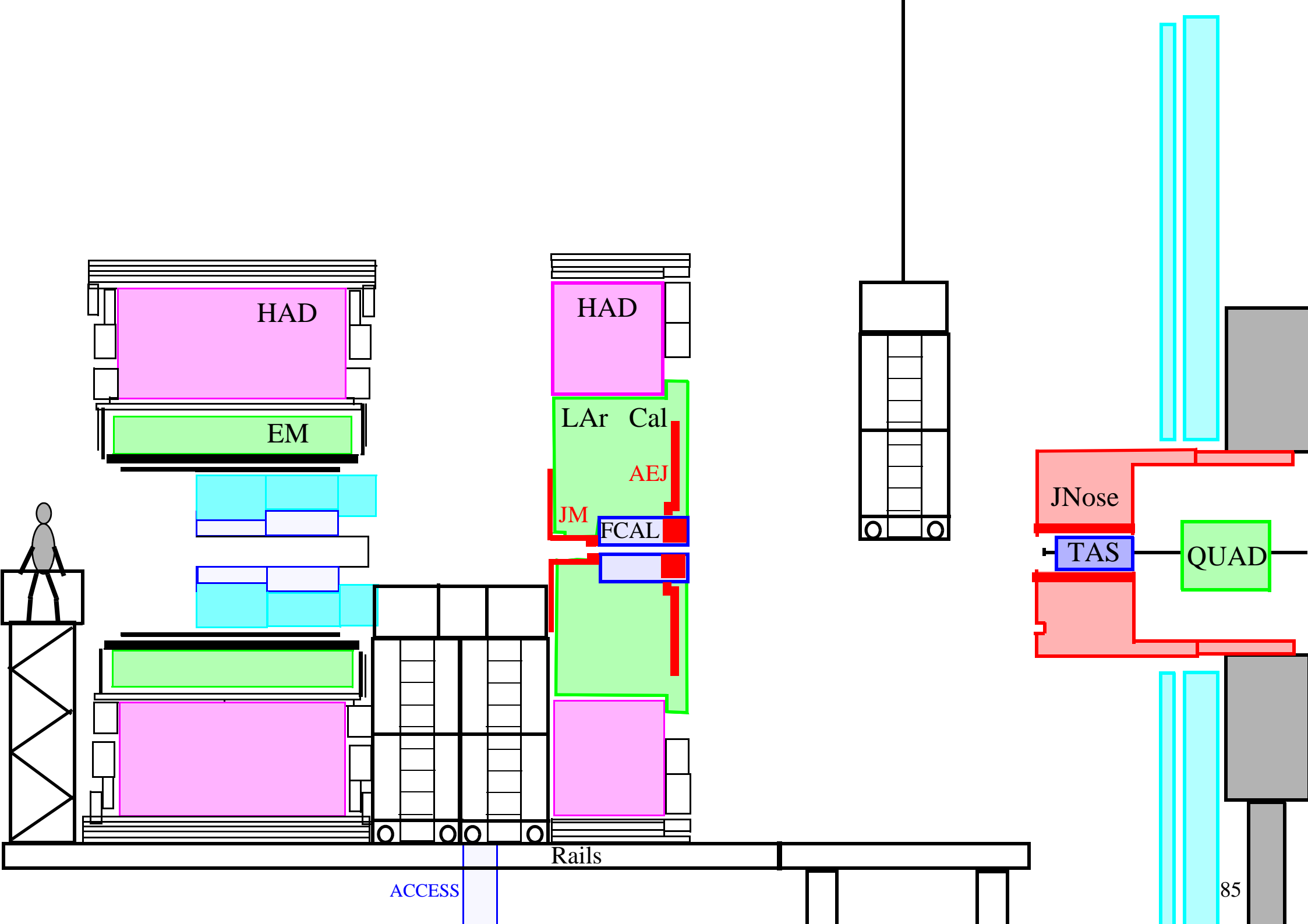

HAD

EM

HAD

LAr Cal

AEJ

JM

FCAL

JNose

TAS

QUAD

Rails

ACCESS

85

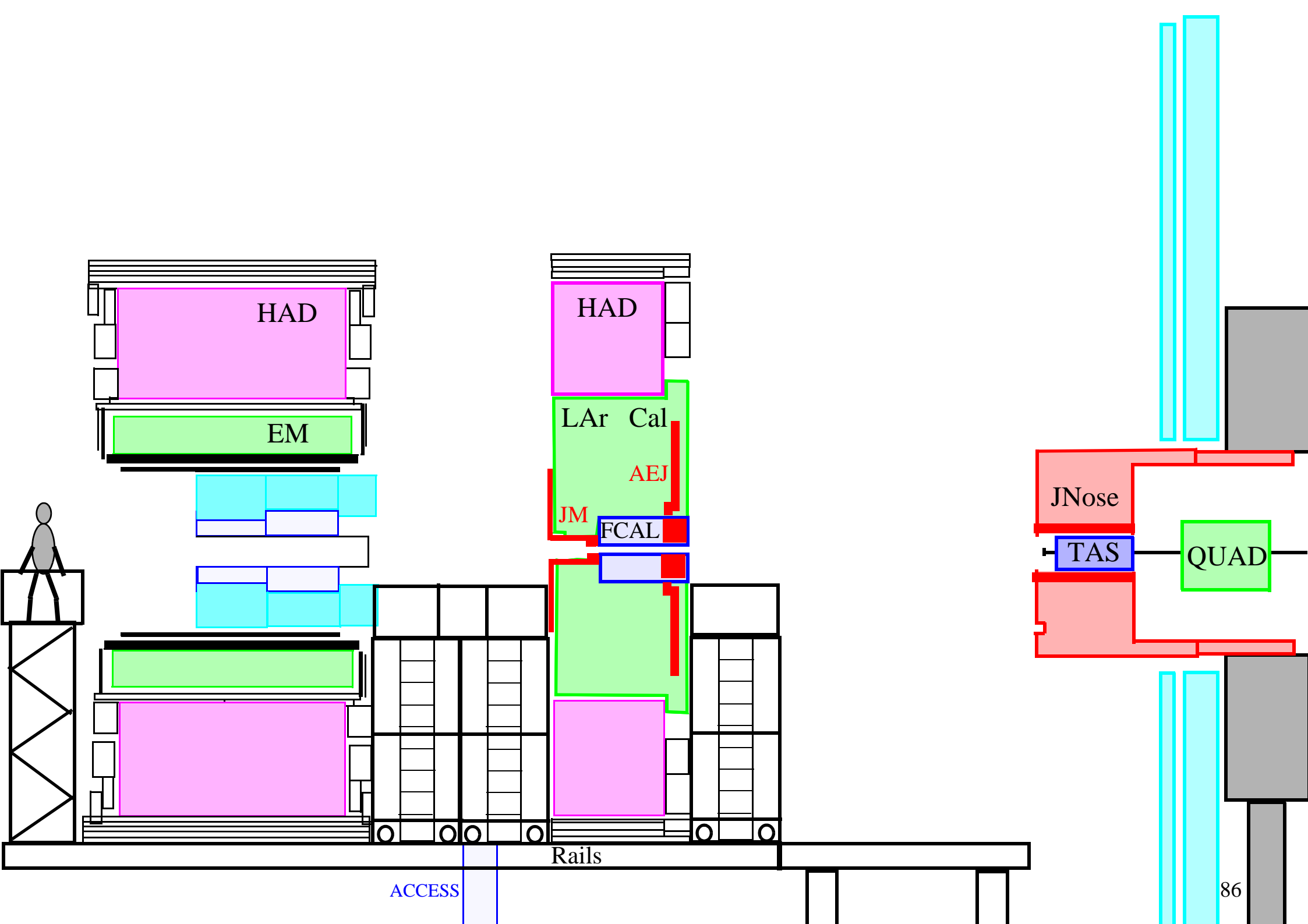

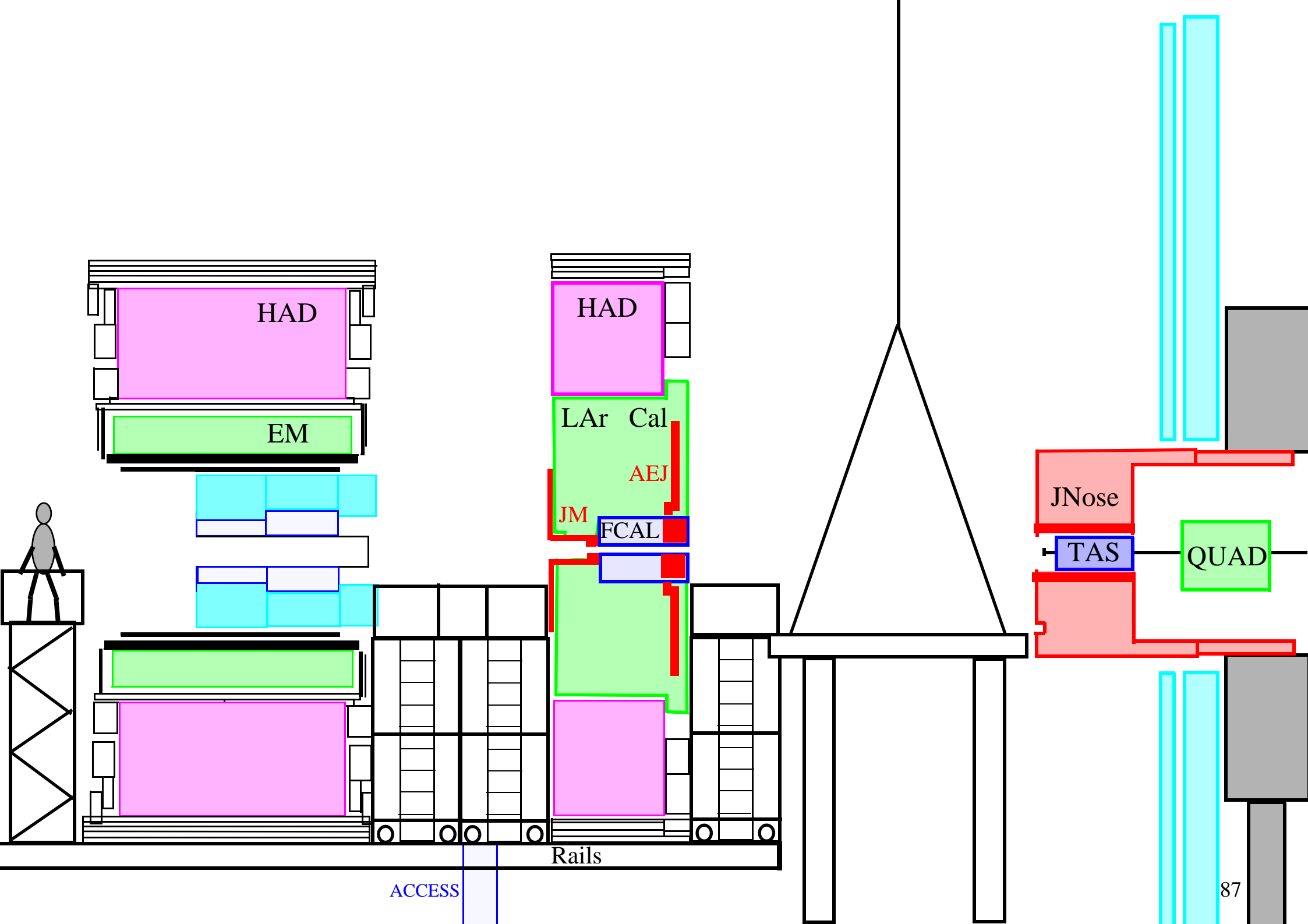

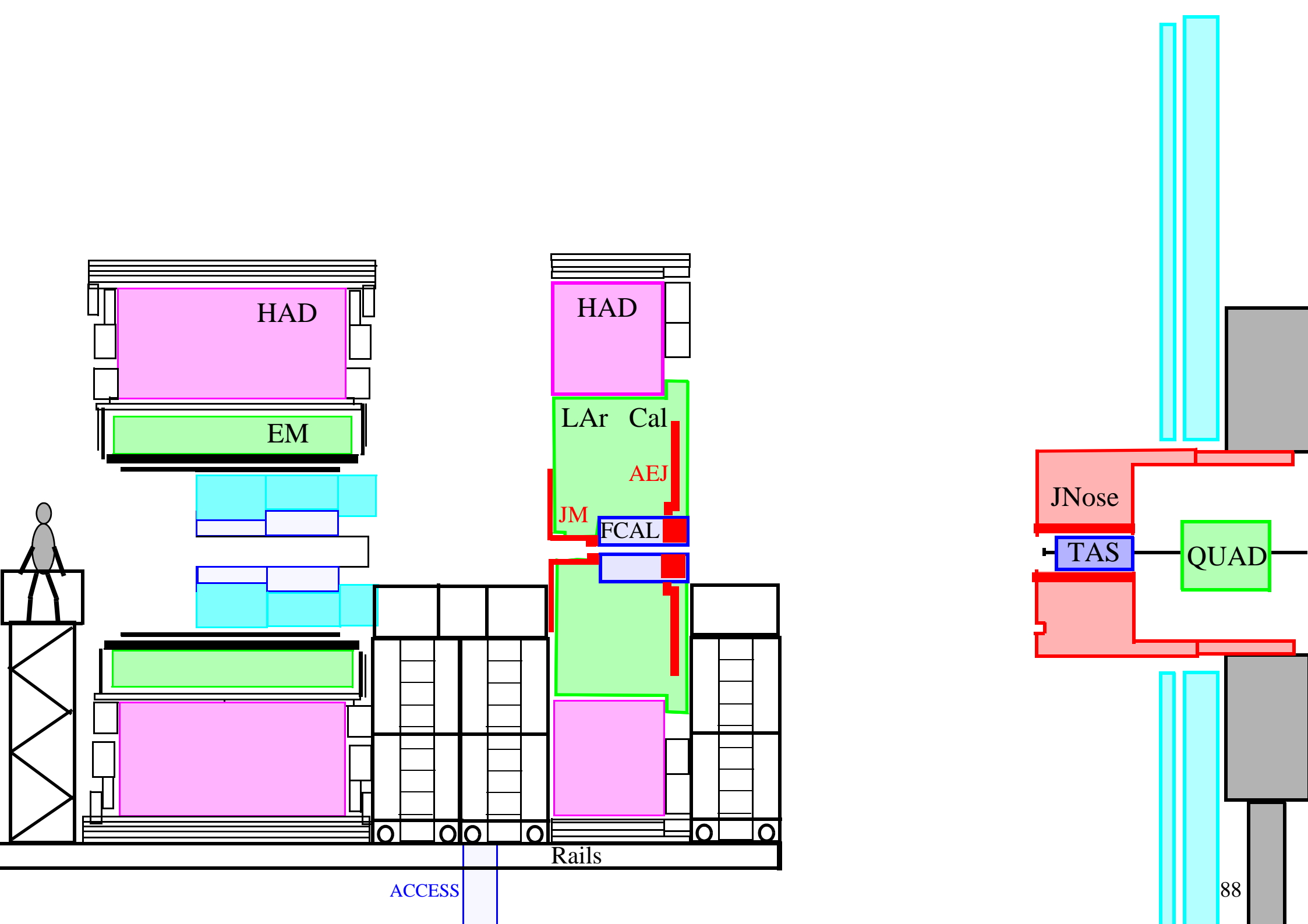

October 2006

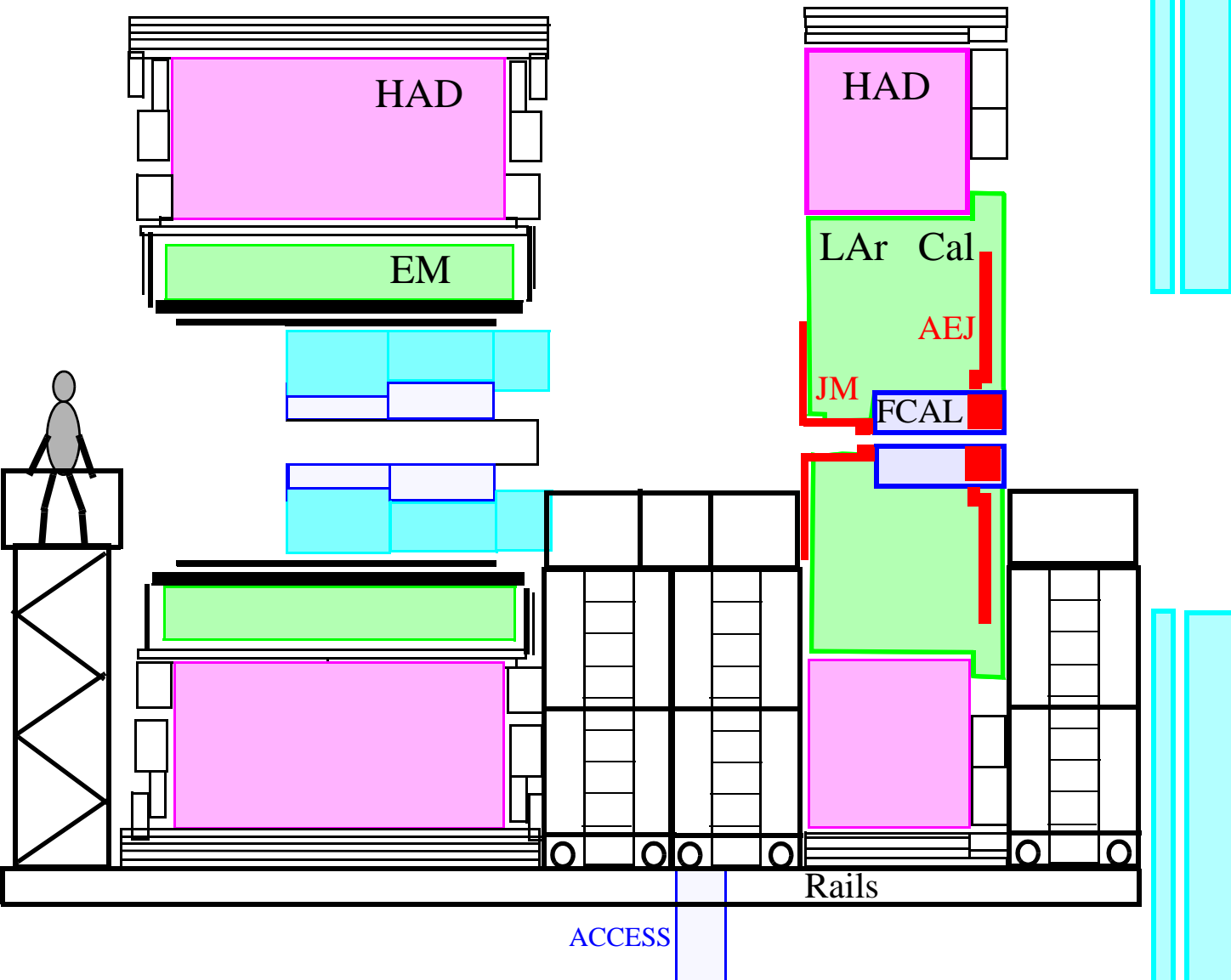

TGC 2

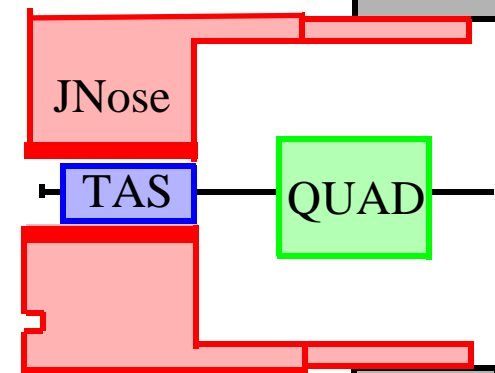

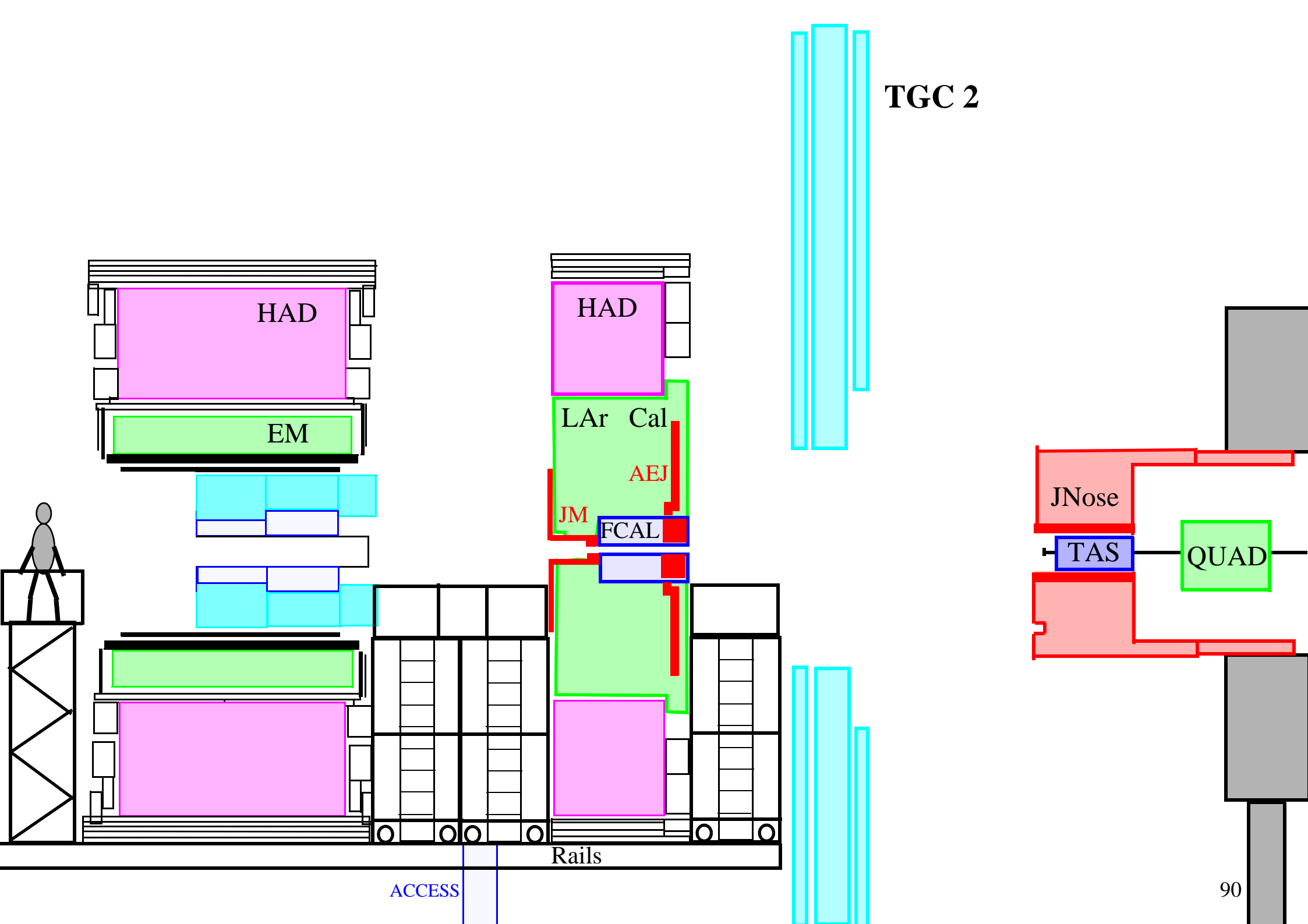

HAD

EM

HAD

LAr Cal

AEJ

JM

FCAL

TGC 2

JNose

TAS

QUAD

Rails

ACCESS

November 2006

ID Endcap A is installed.

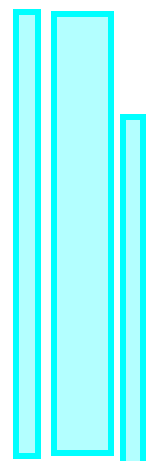
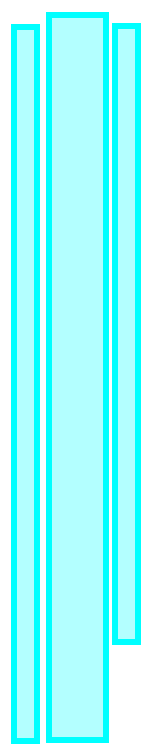
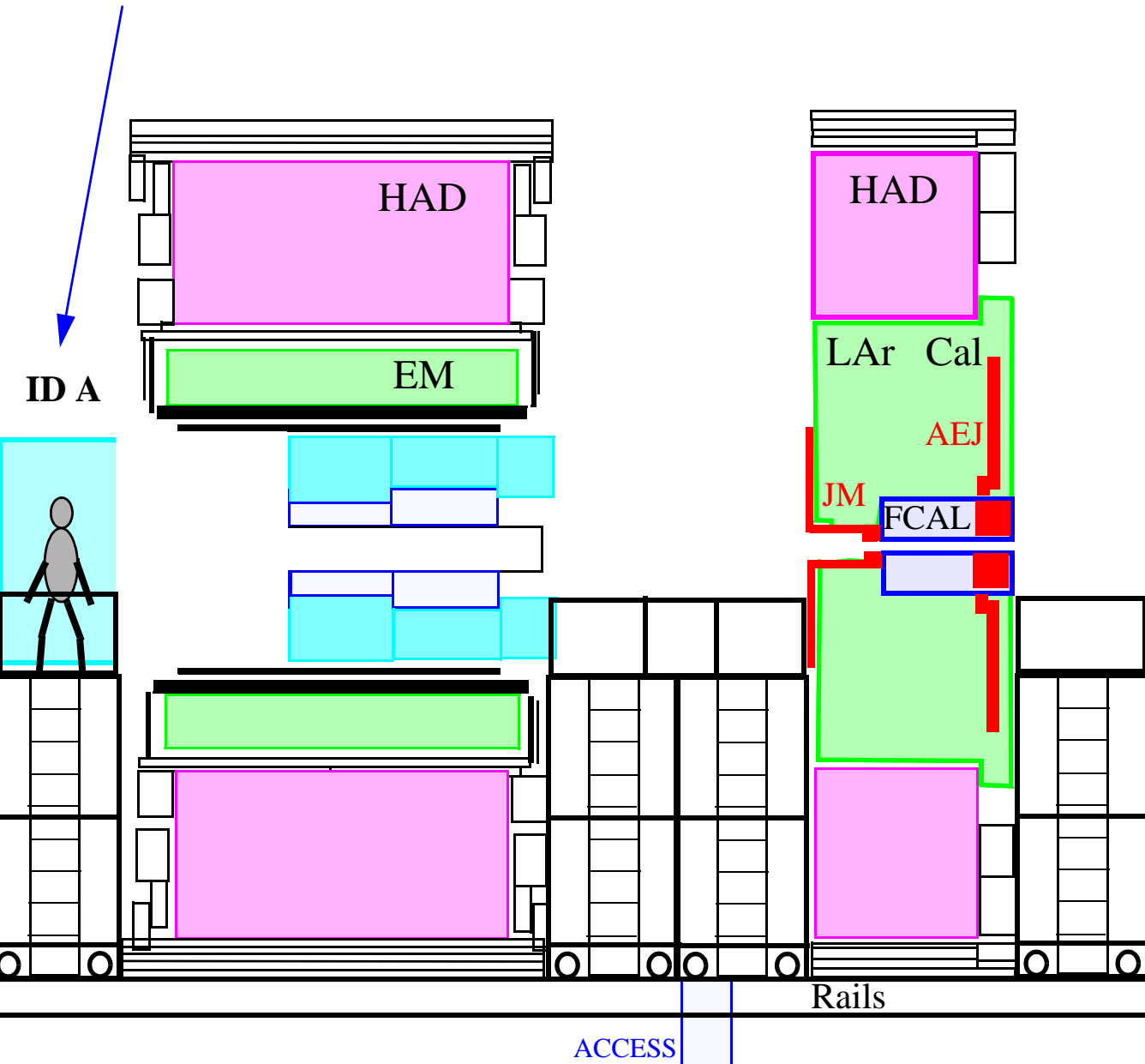

TGC 3

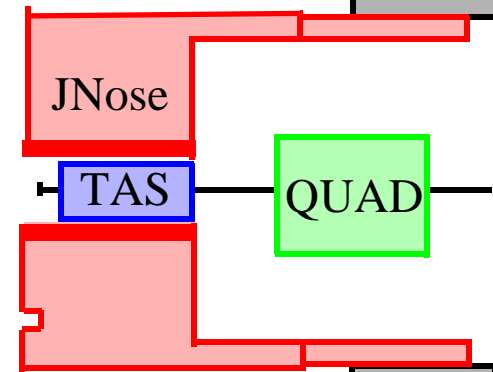

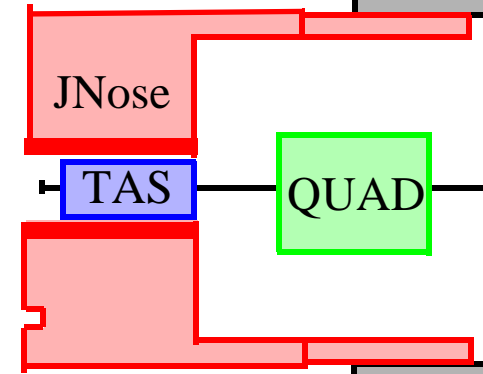
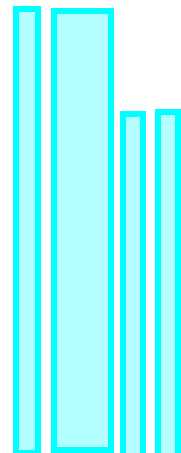
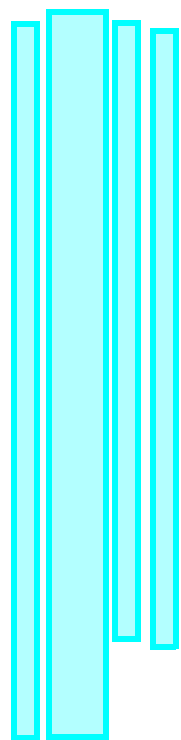
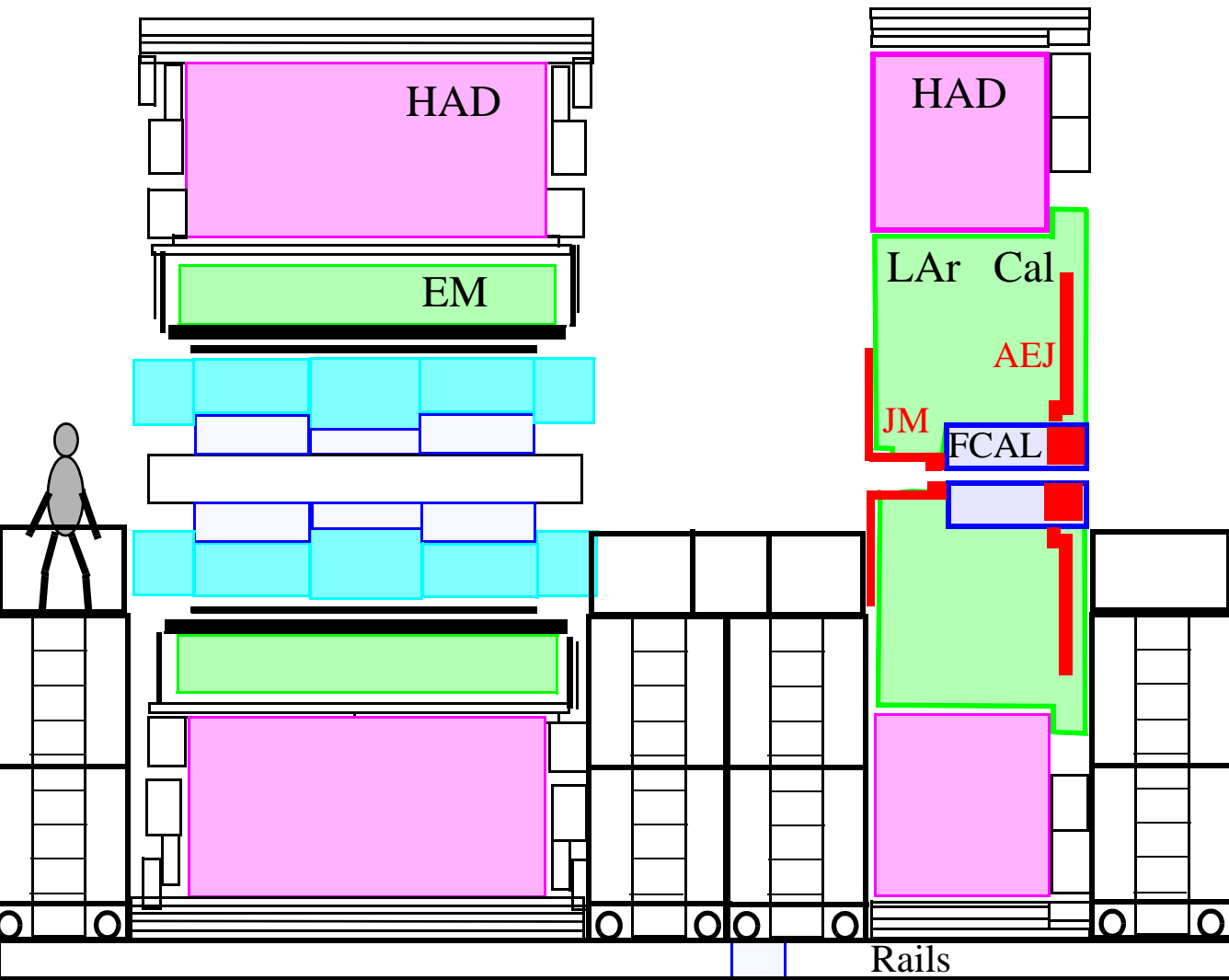

Is this the right time to install the washers ?

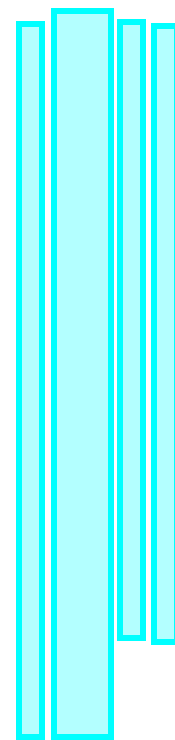
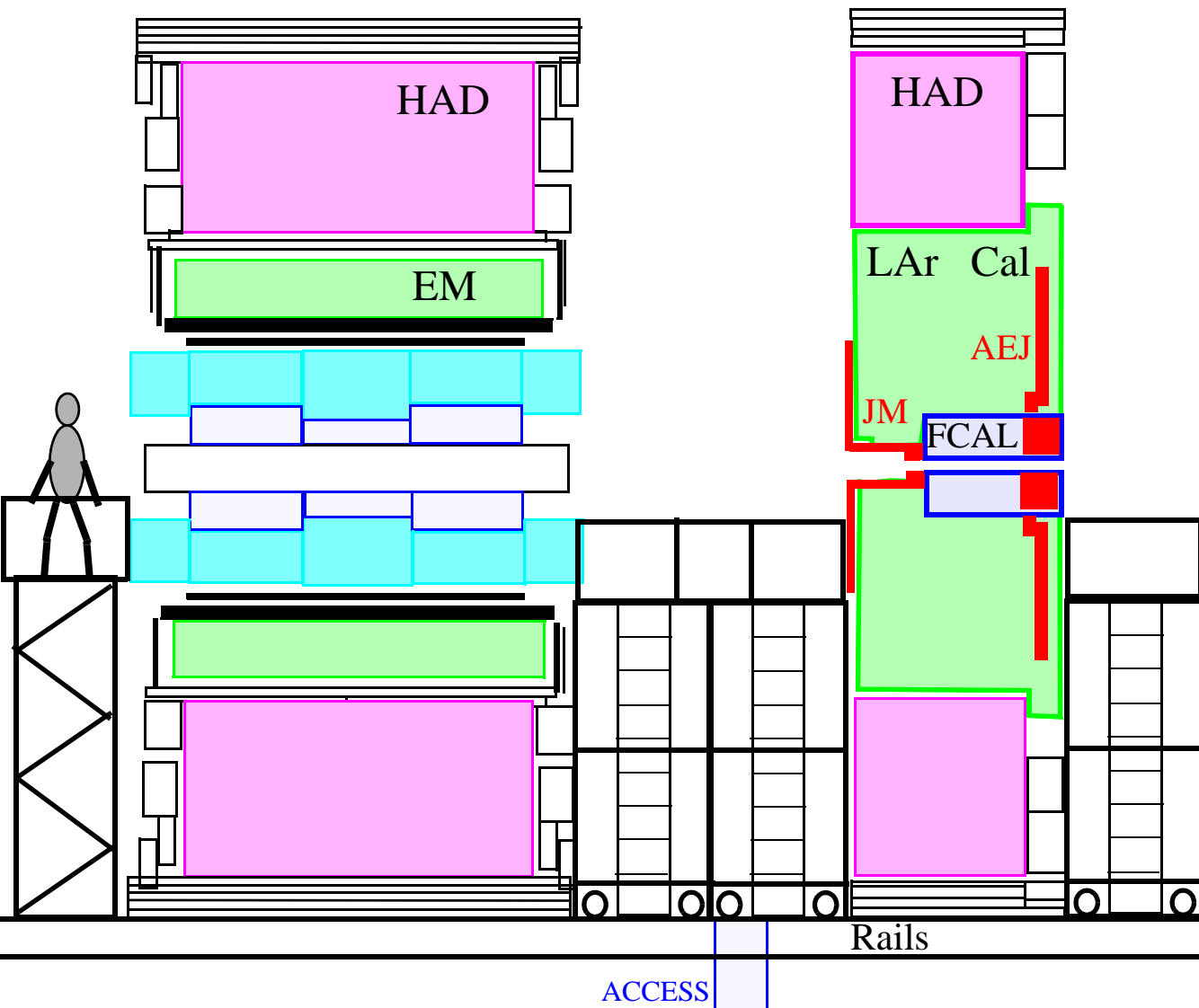

WASHERS

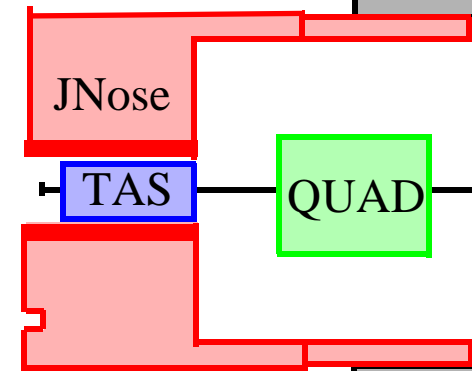

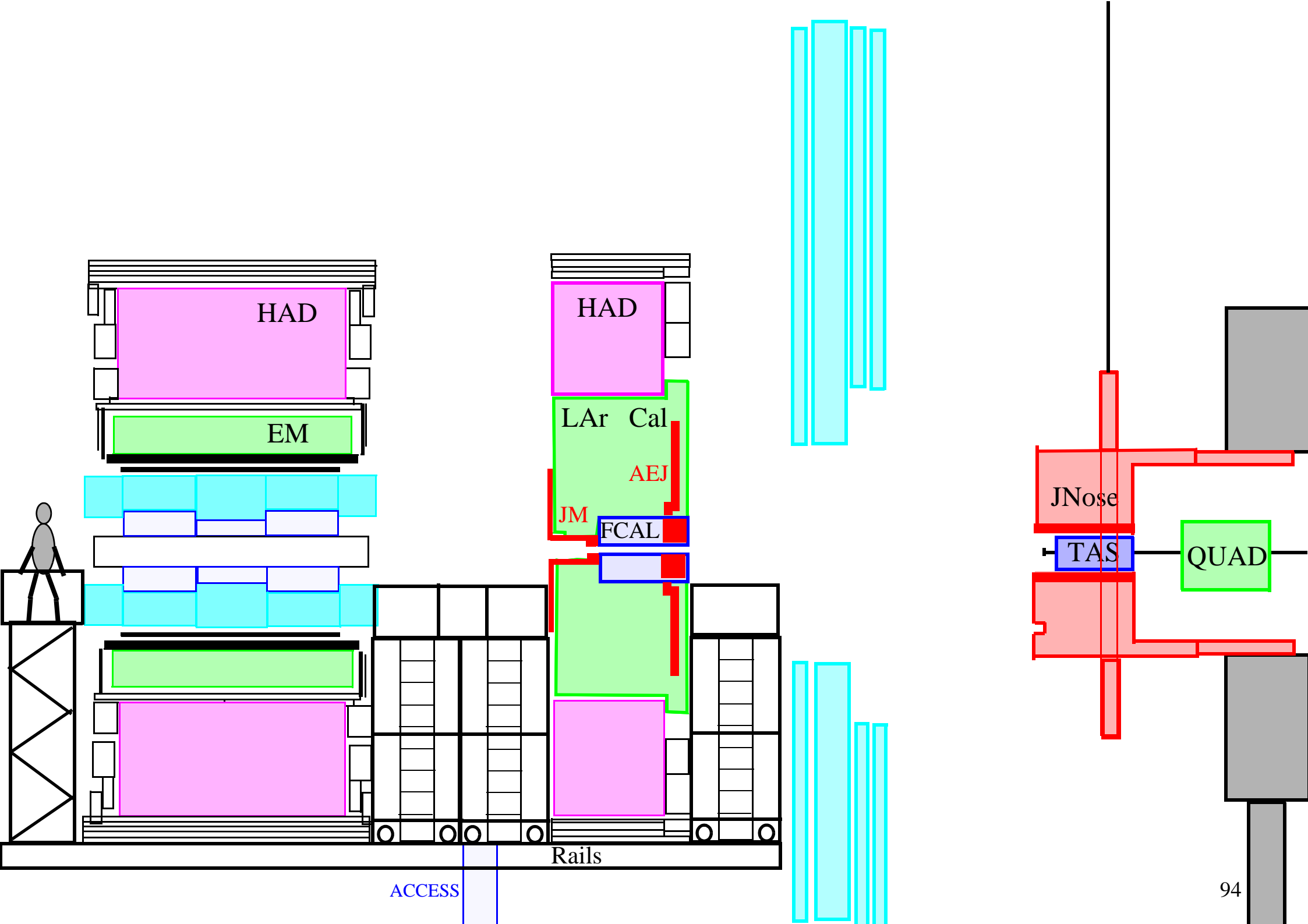

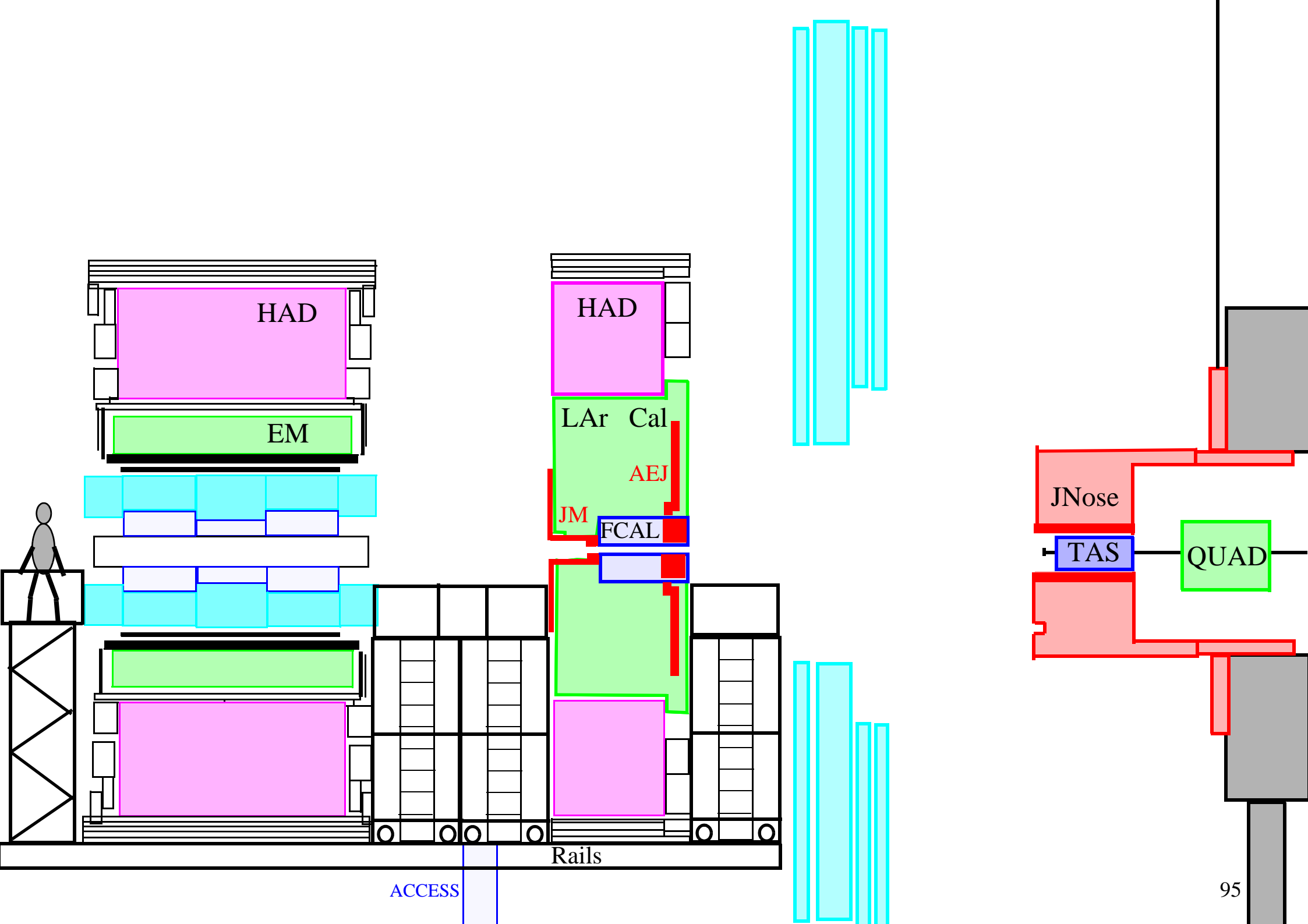

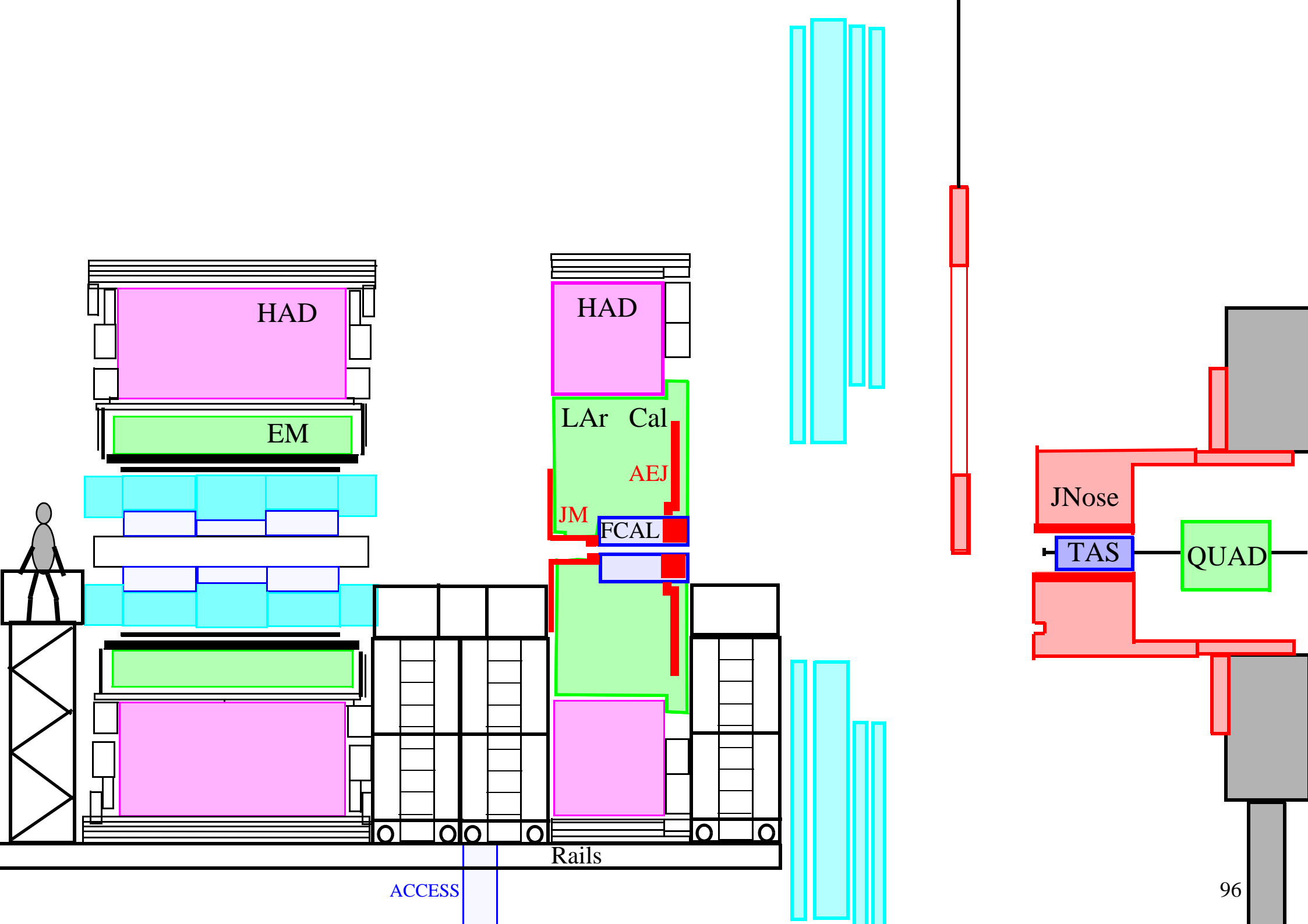

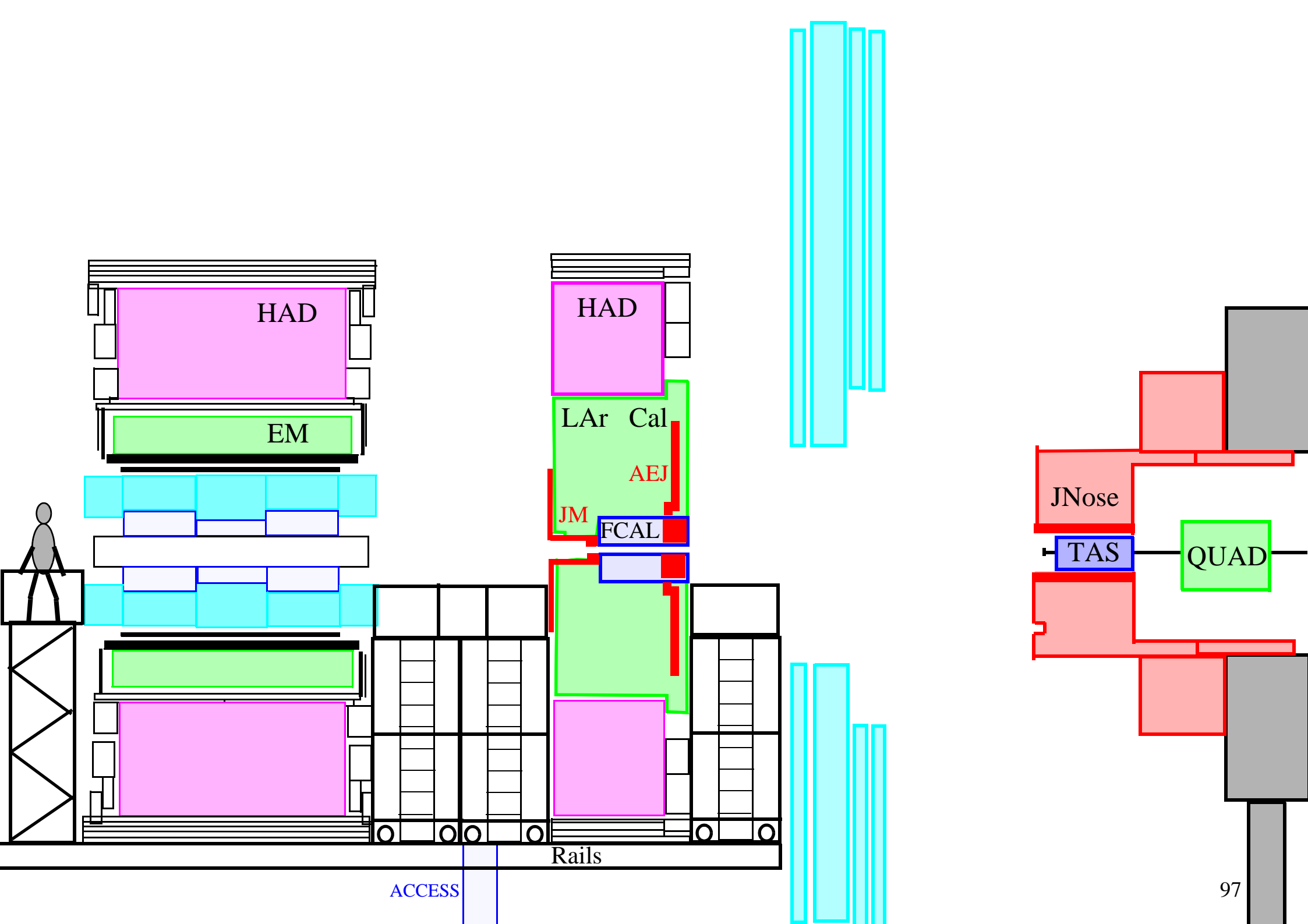

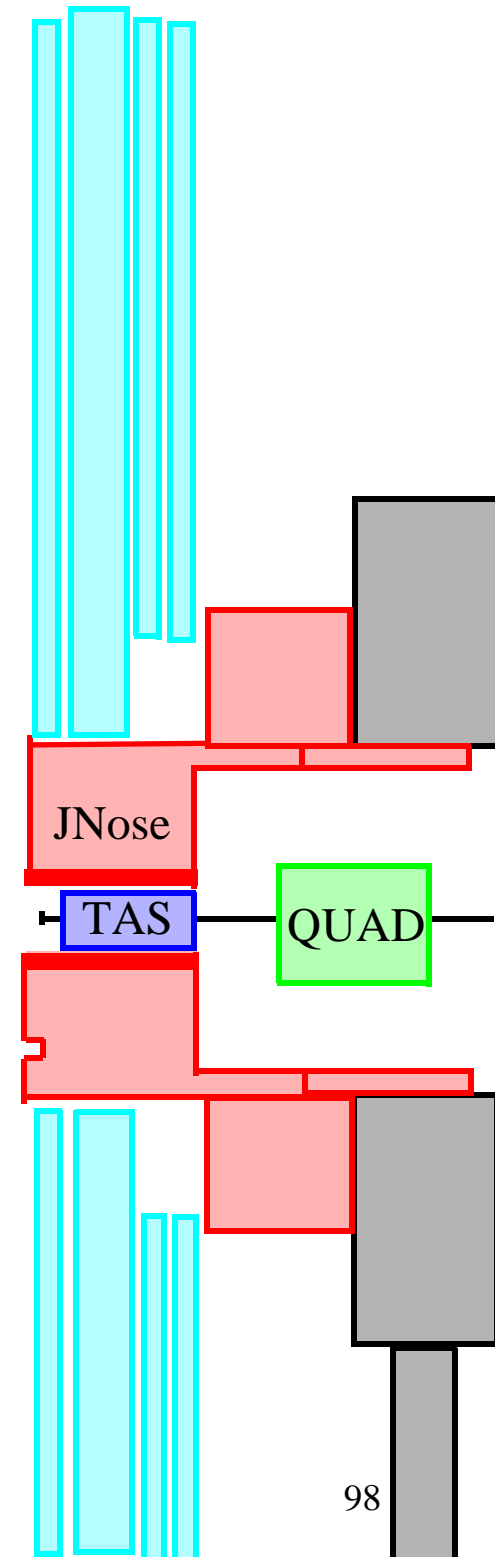
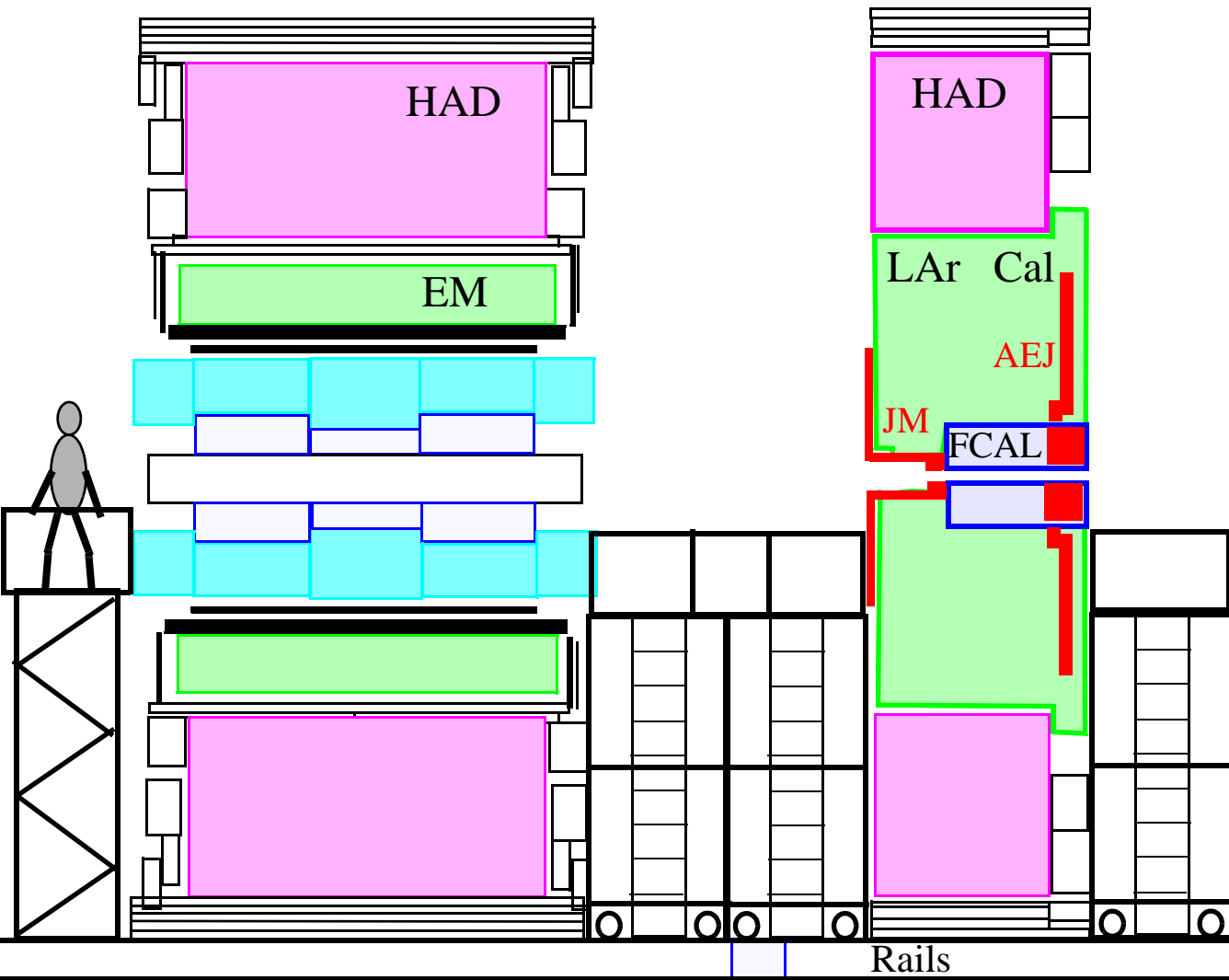

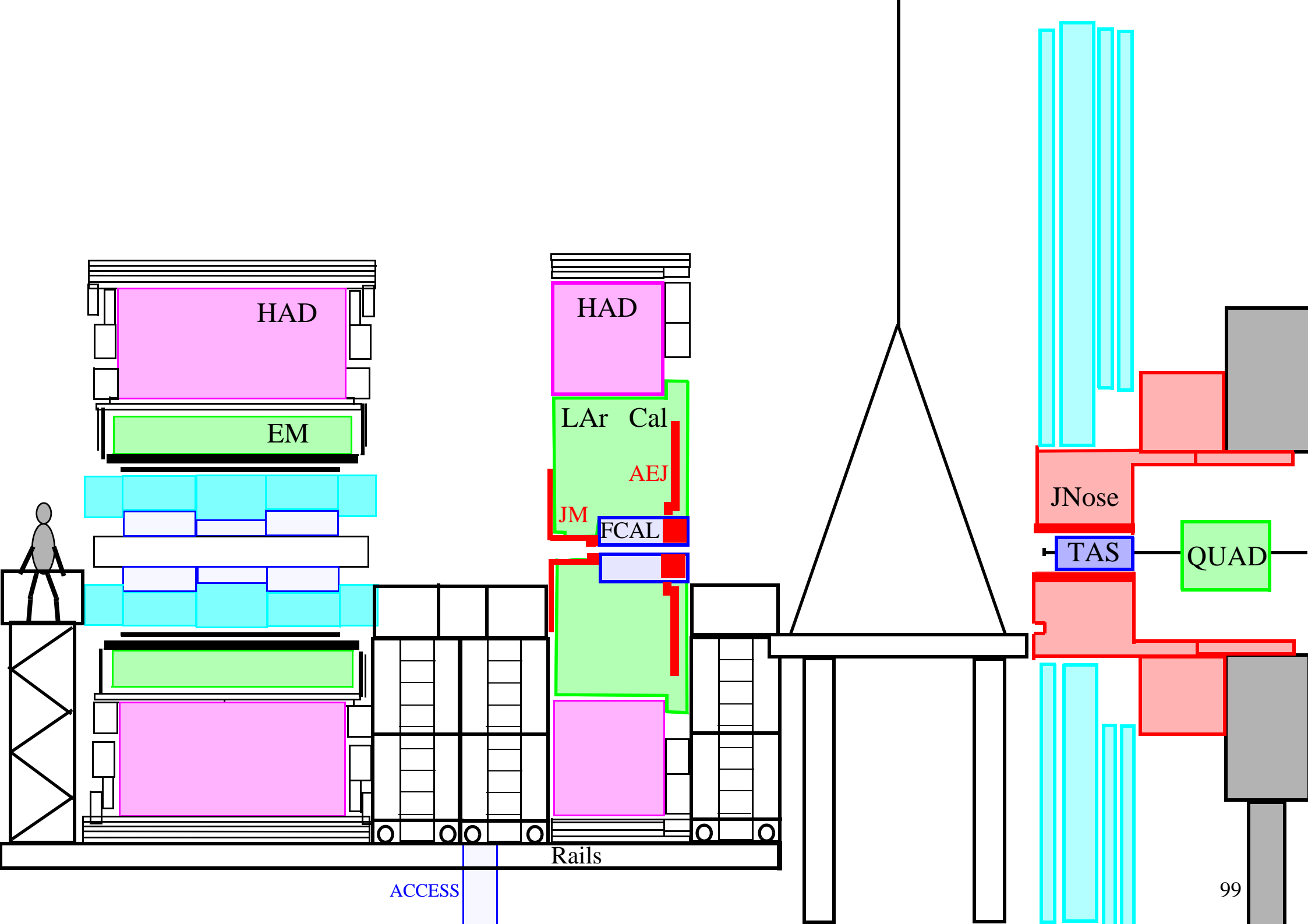

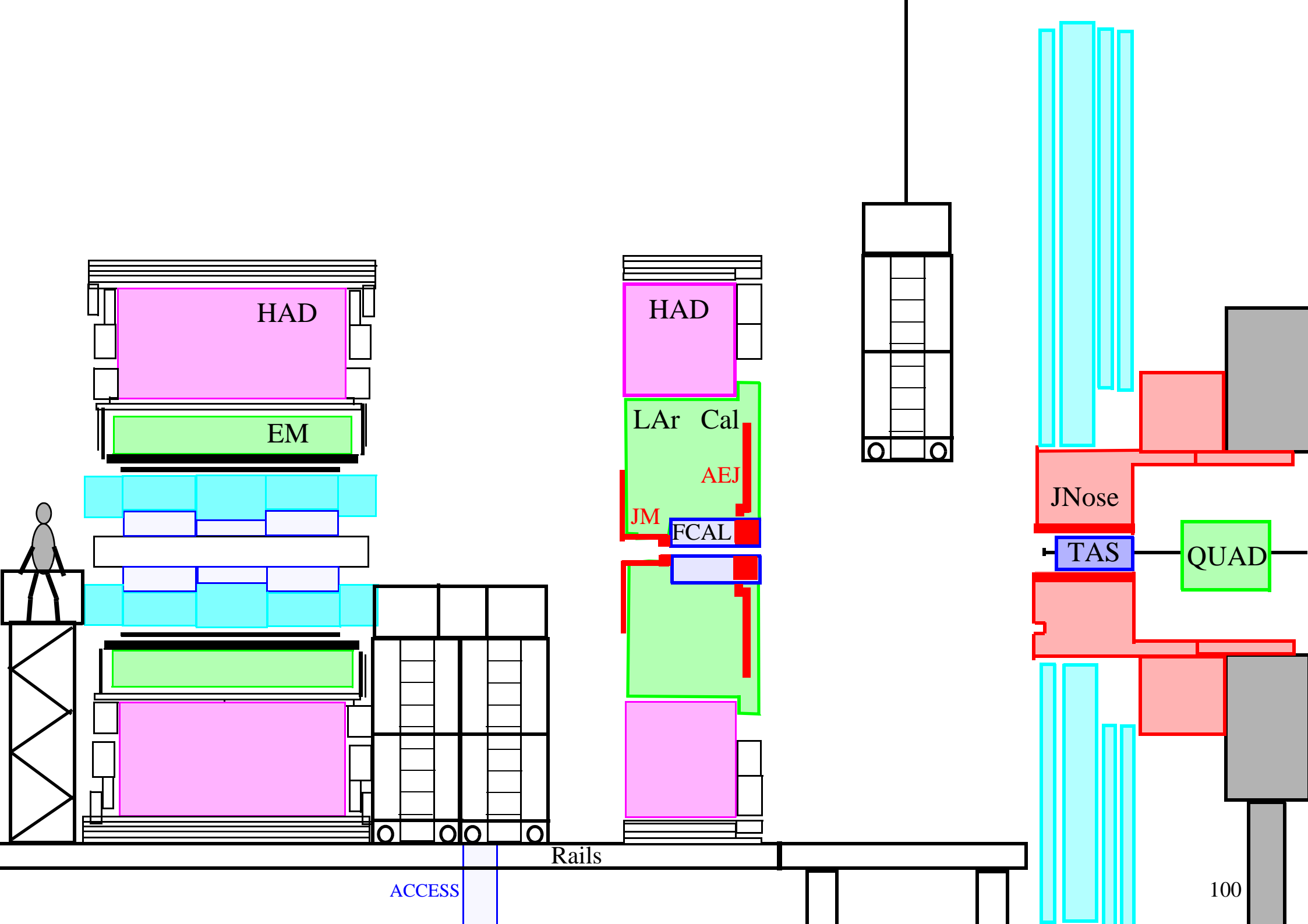

HAD

EM

HAD

LAr Cal

AEJ

JM

FCAL

JNose

TAS

QUAD

Rails

ACCESS

100

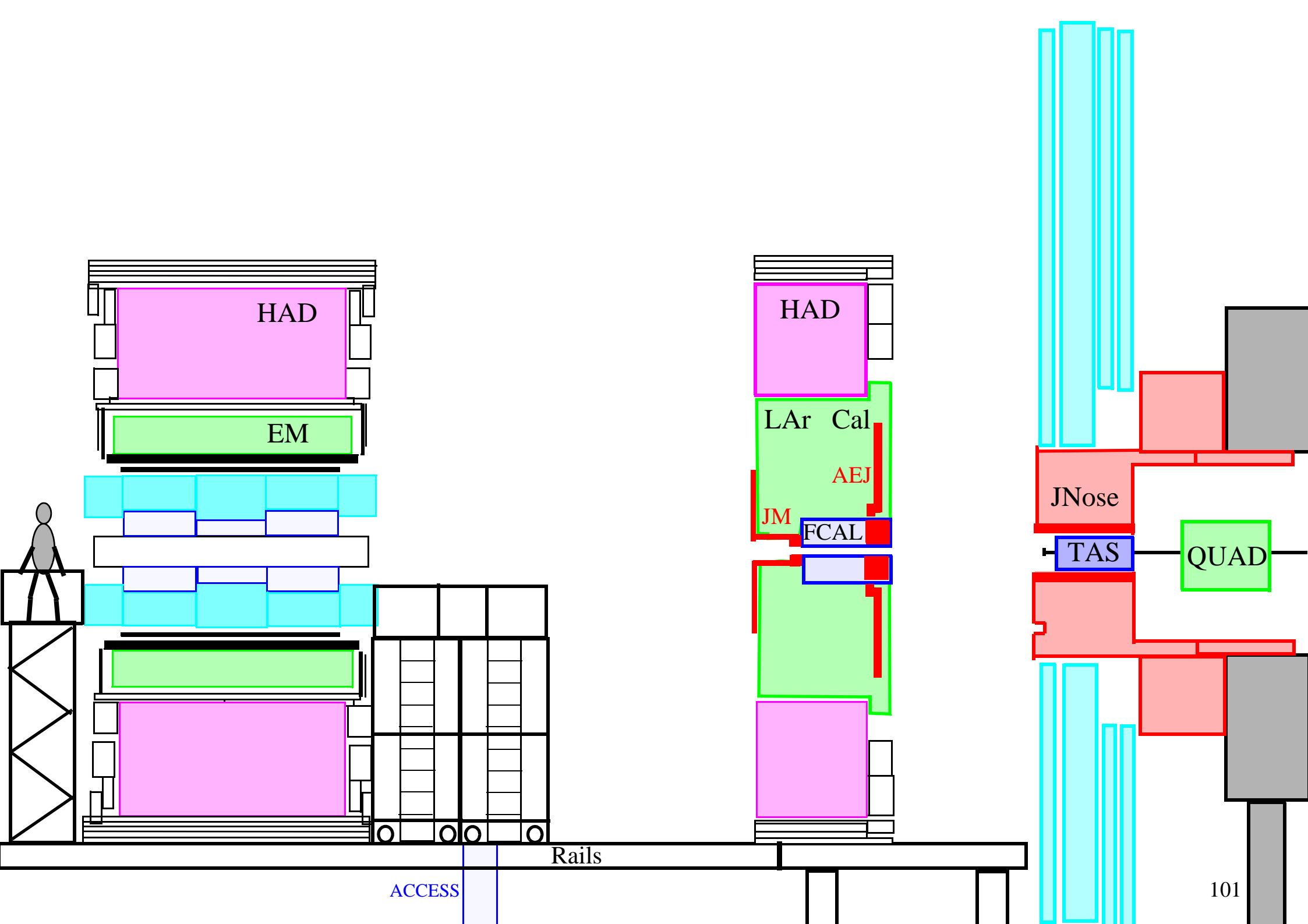

HAD

EM



HAD

LAr Cal

AEJ

JM

FCAL

JNose

TAS

QUAD

Rails

ACCESS

101

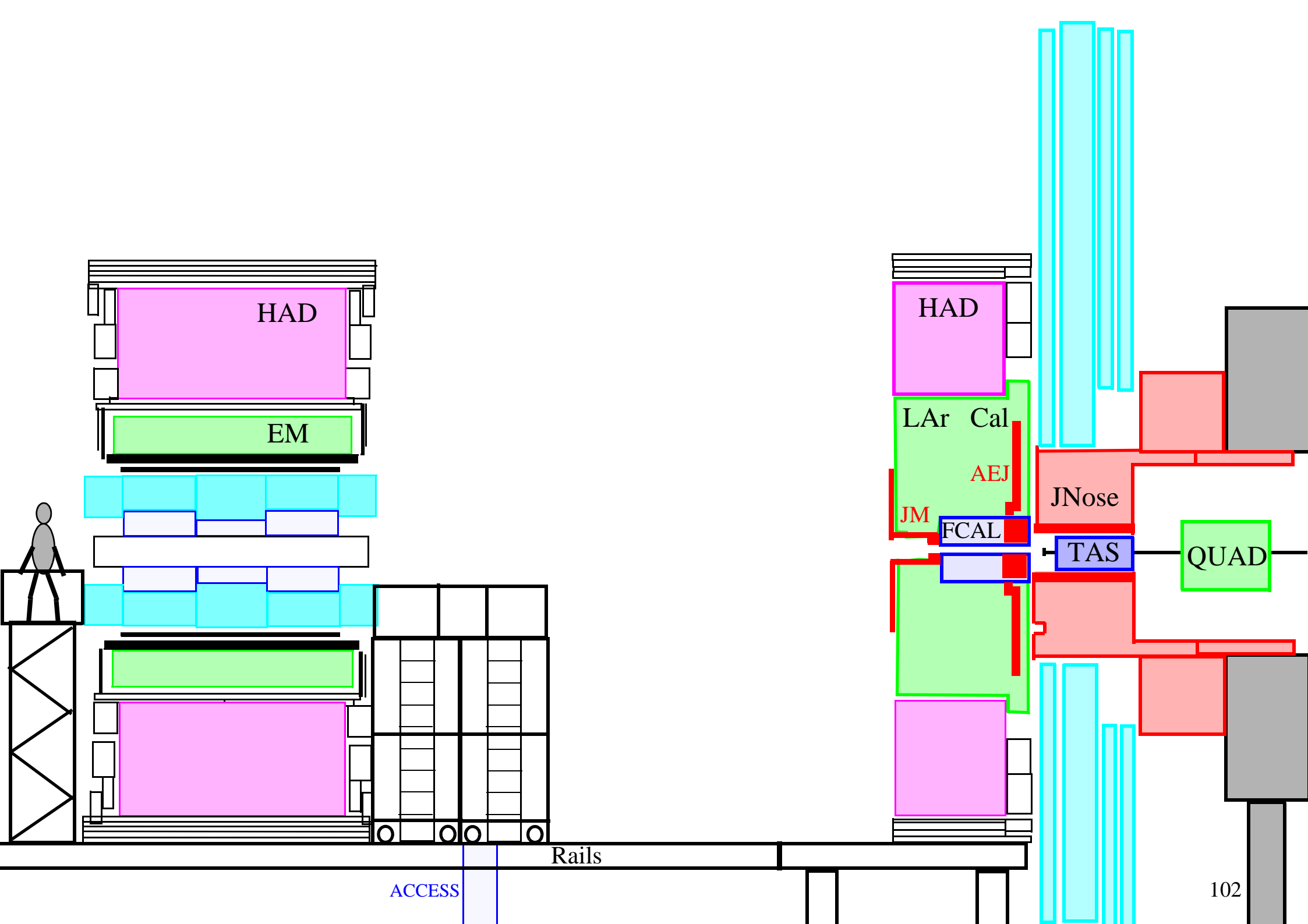

HAD

EM

HAD

LAr Cal

AEJ

JM

FCAL

JNose

TAS

QUAD

Rails

ACCESS

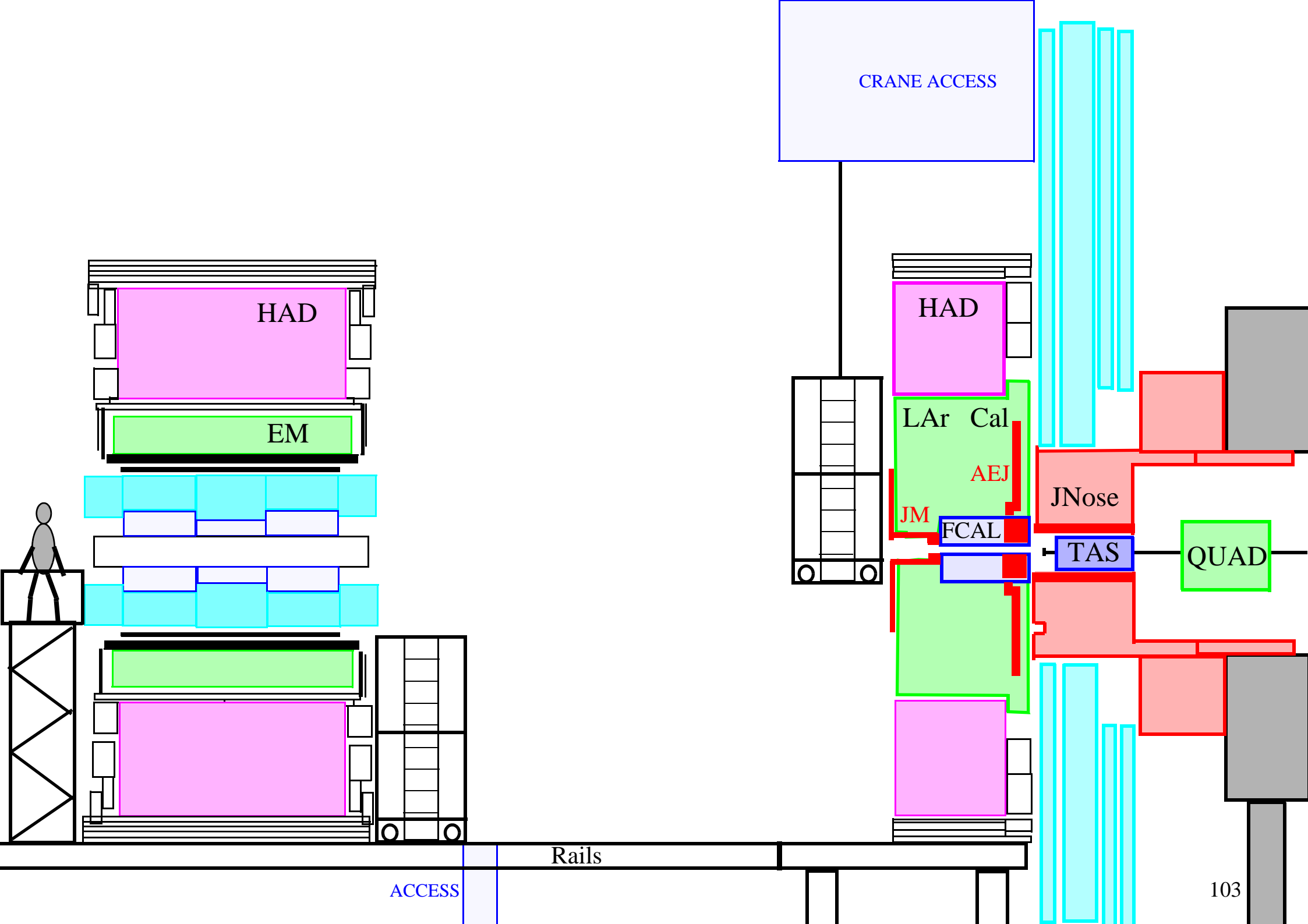

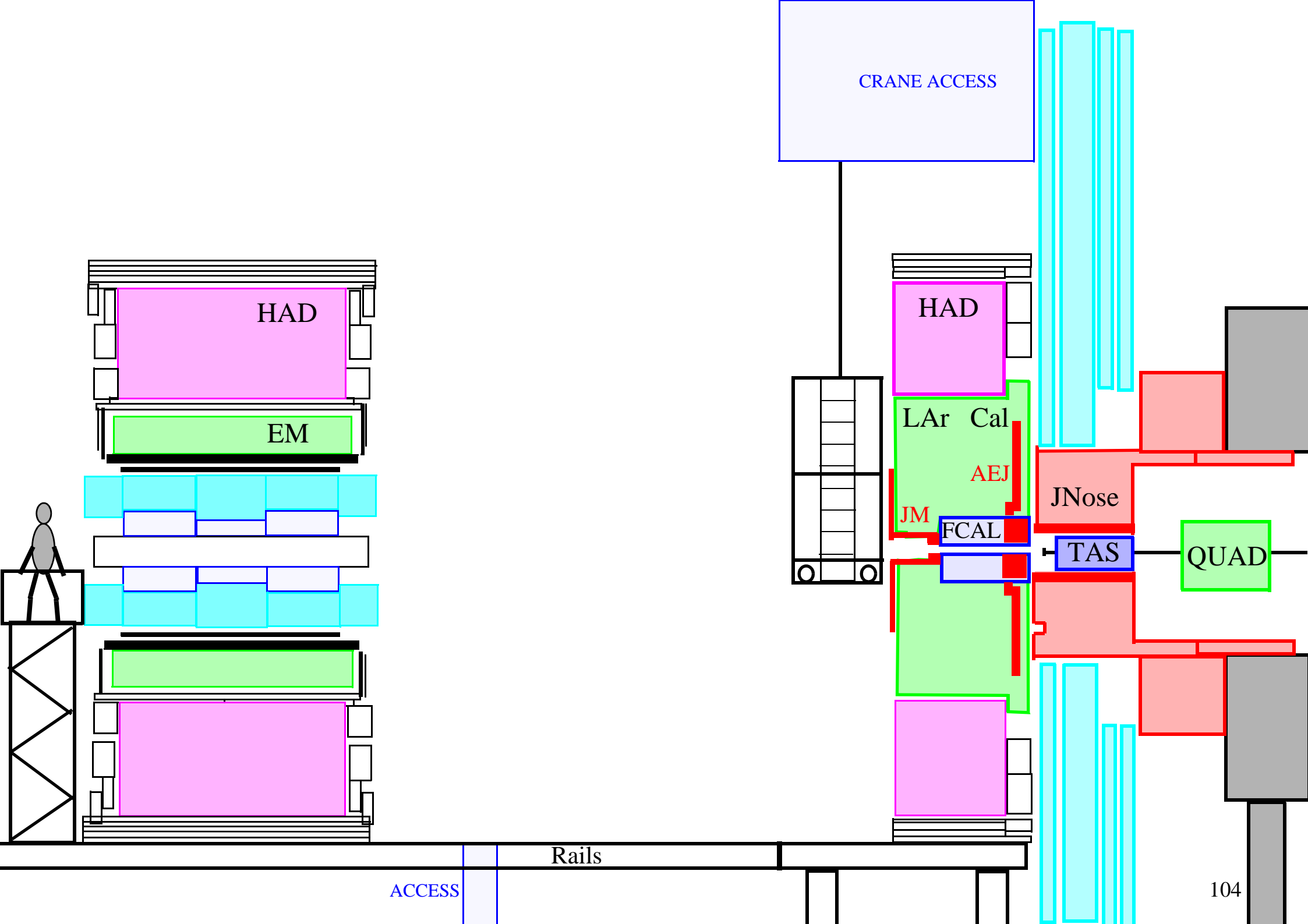

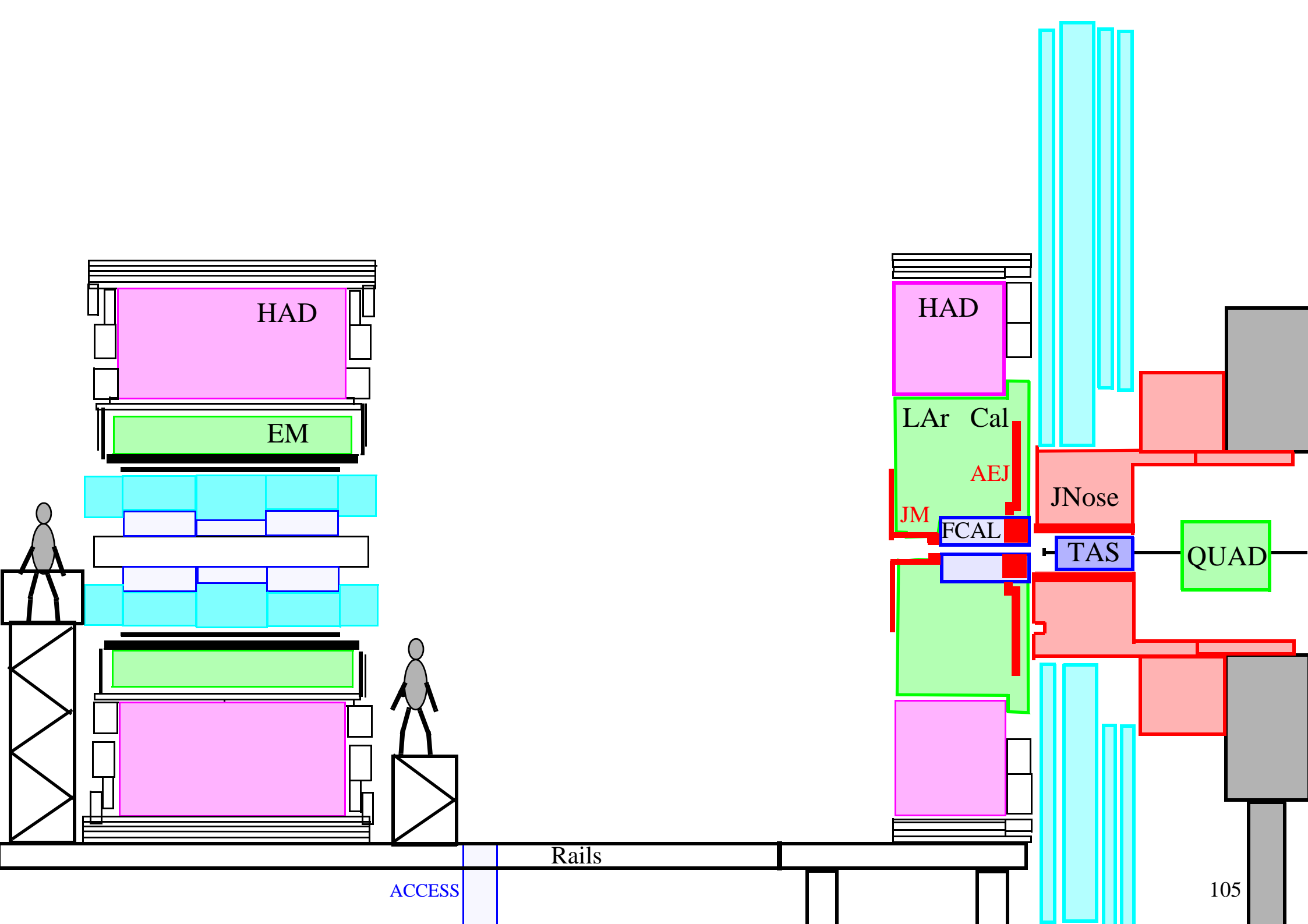

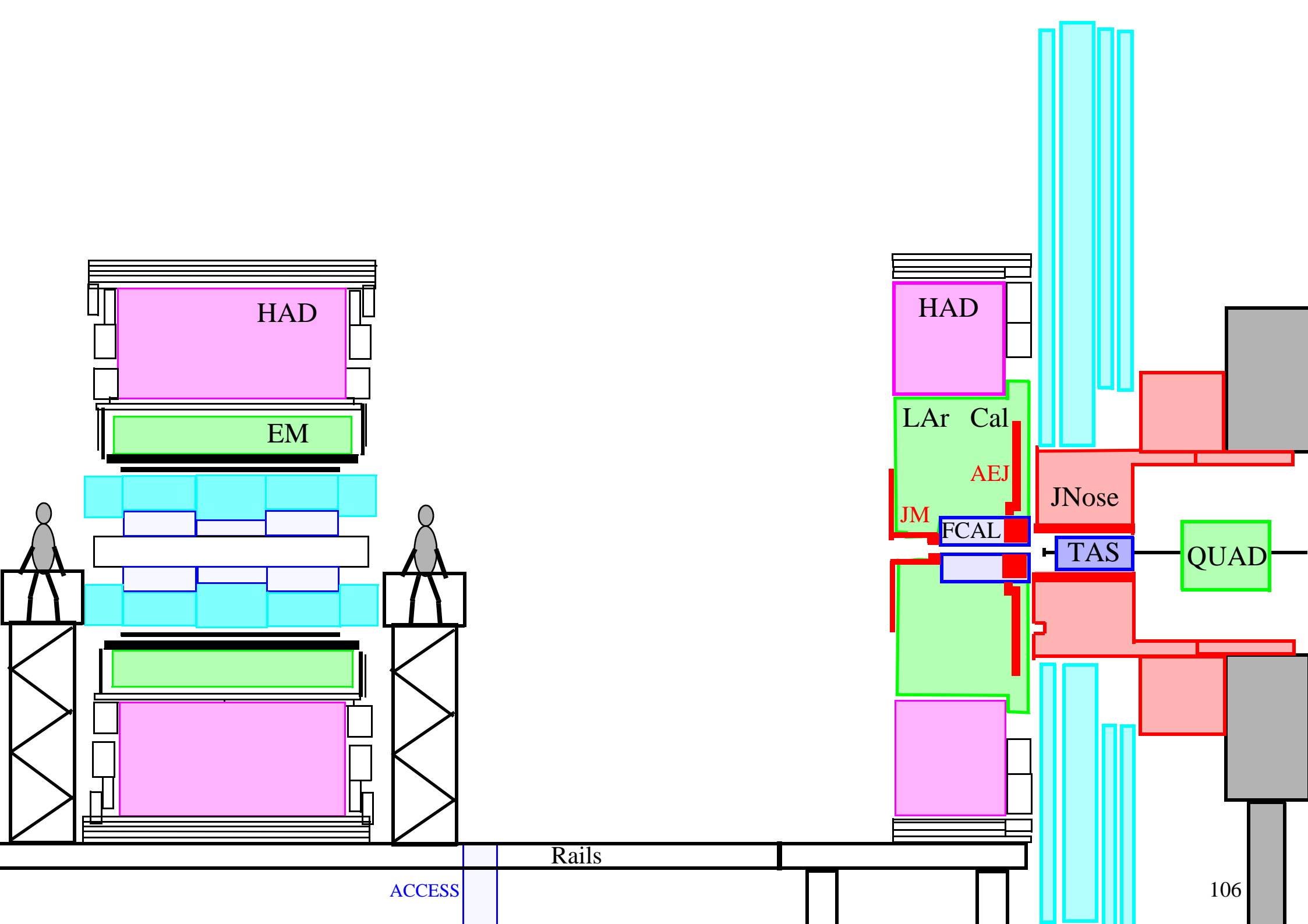

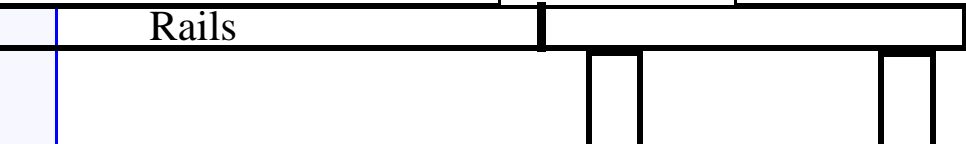
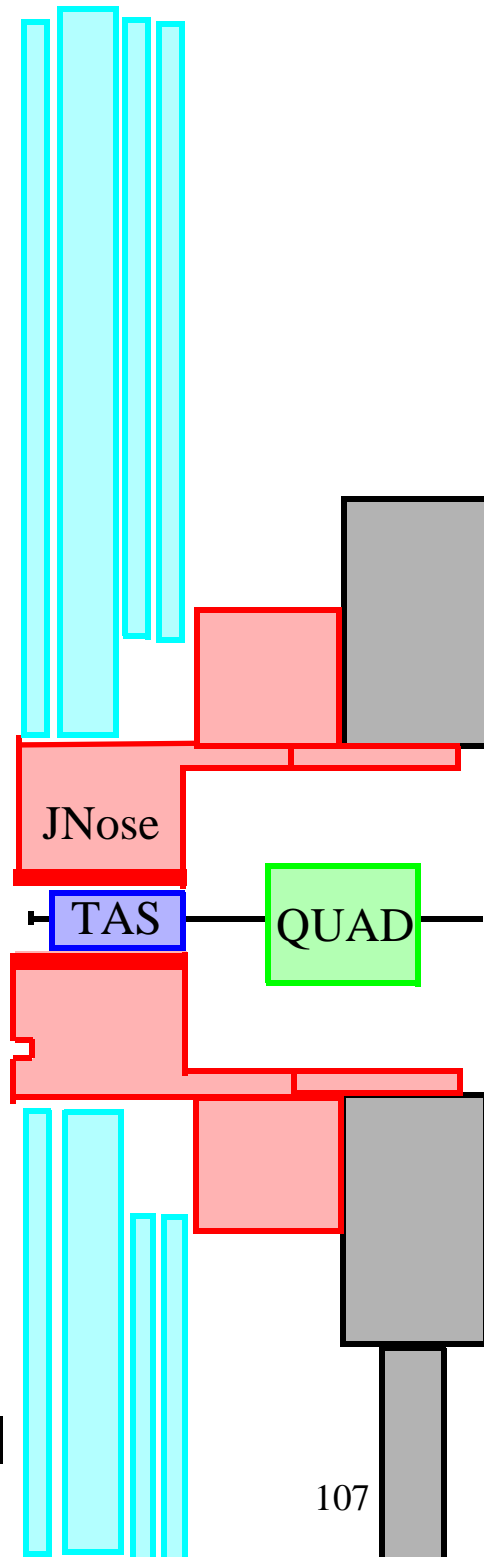
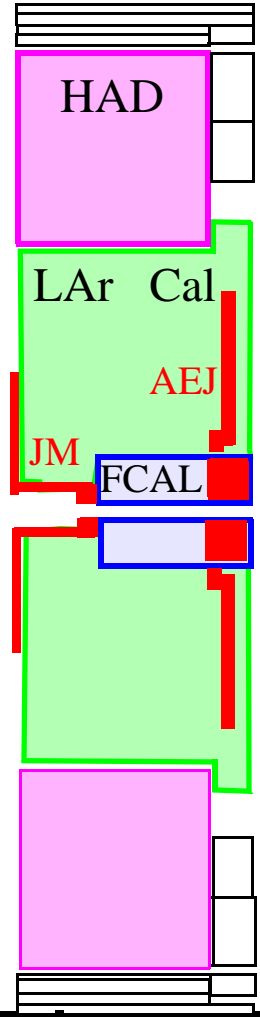
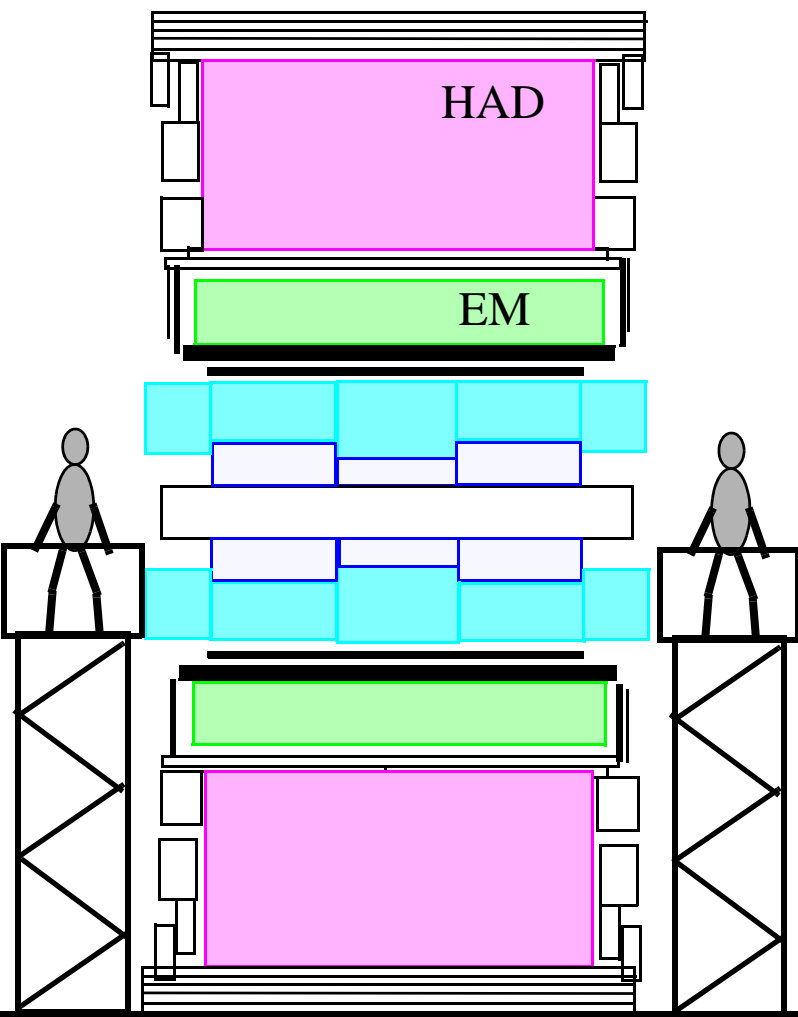

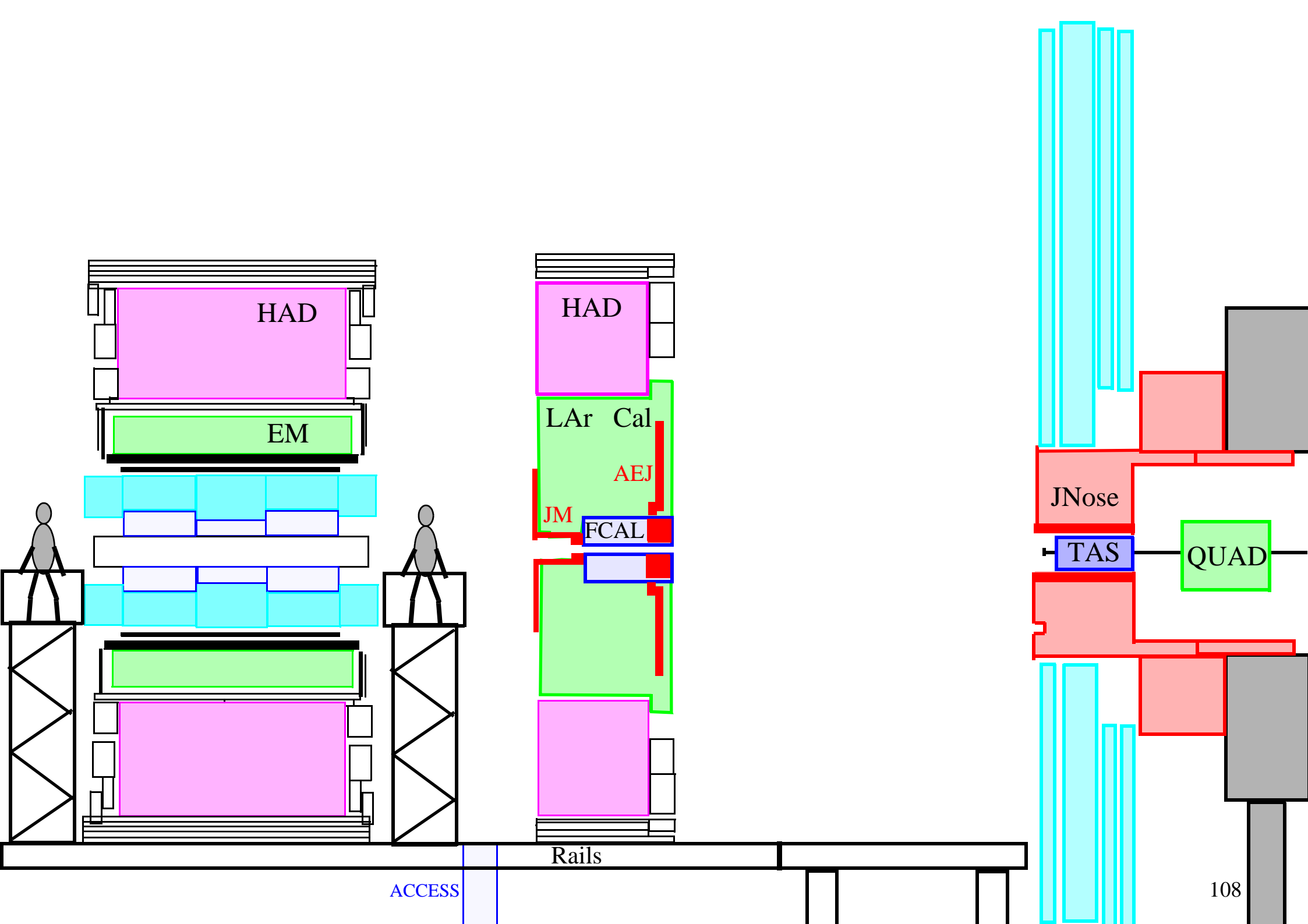

No access by the lift !

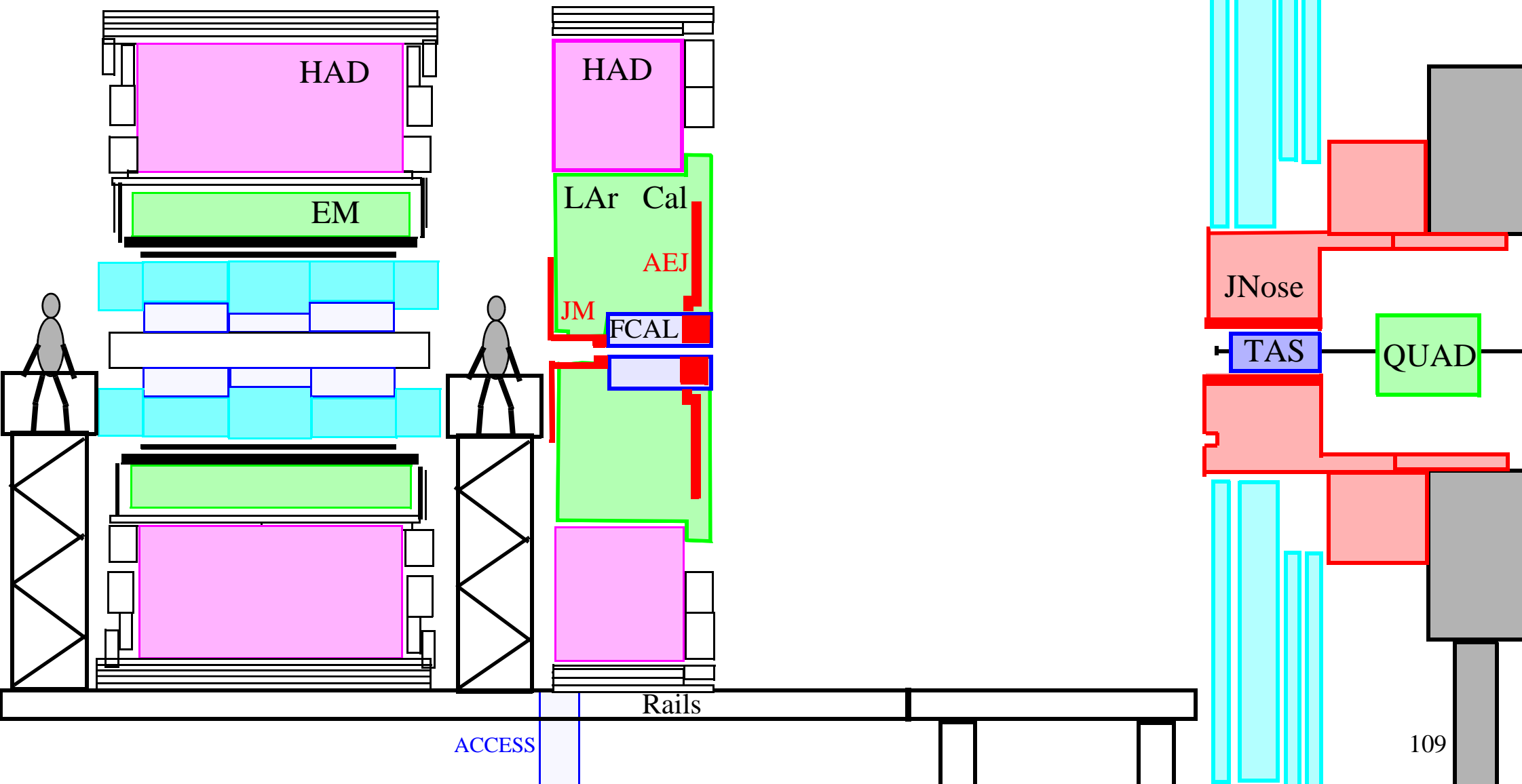

December 2006

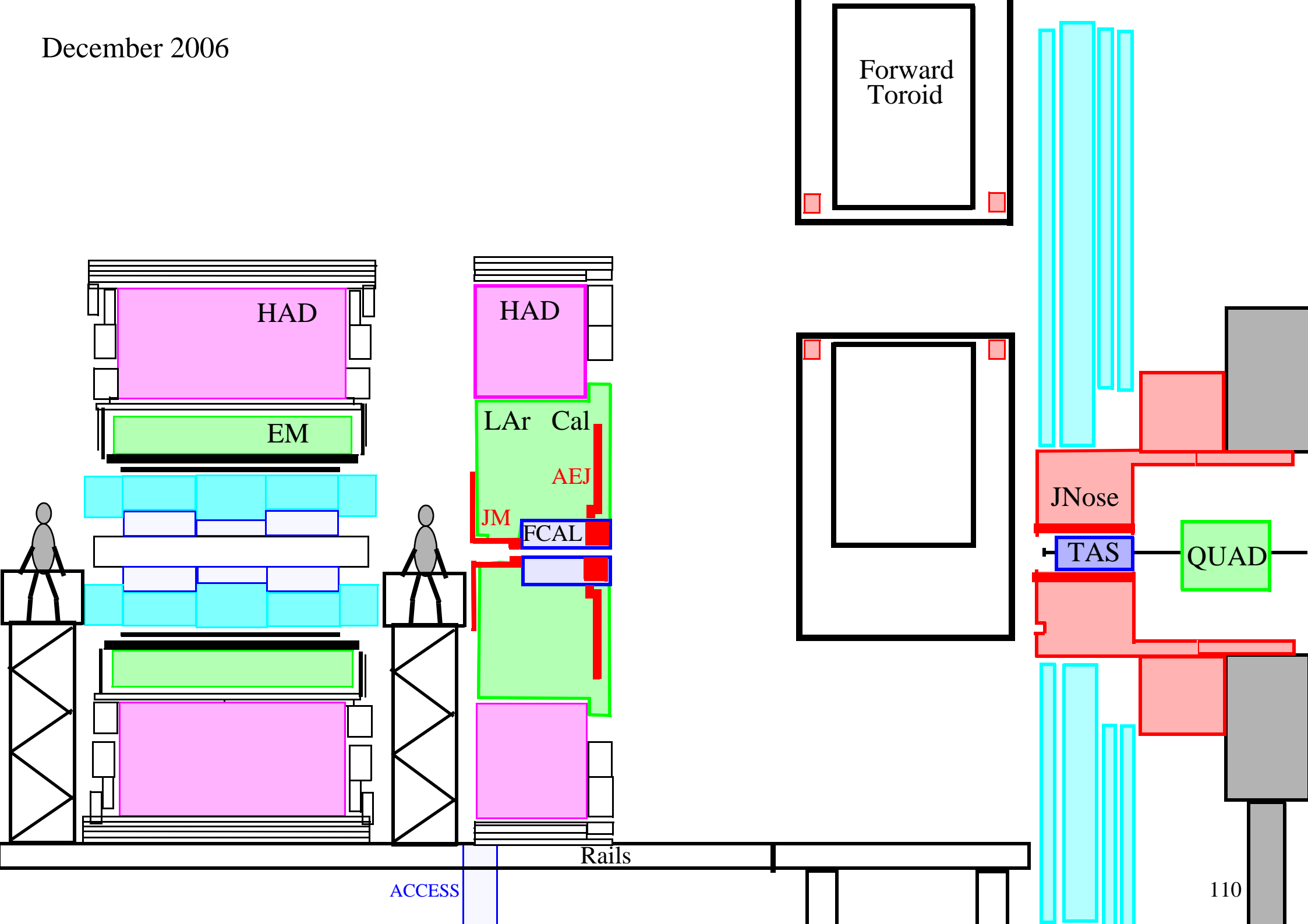

Forward
Toroid

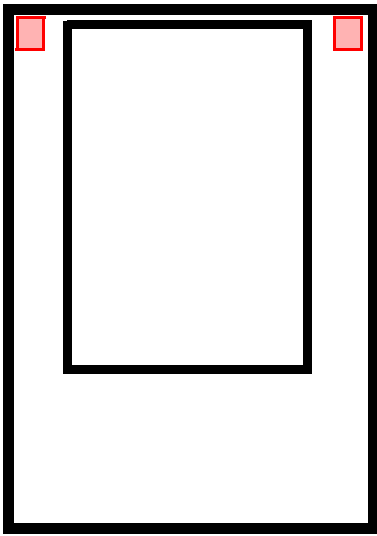

HAD
EM

HAD
LAr Cal

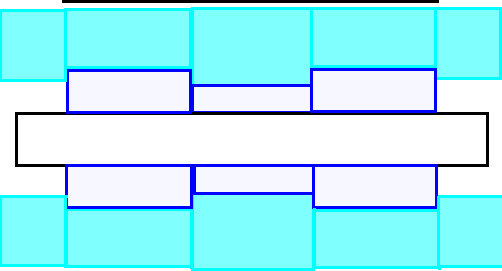

AEJ
JM
FCAL

EM
HAD

HAD

Rails

ACCESS

JNose
TAS
QUAD

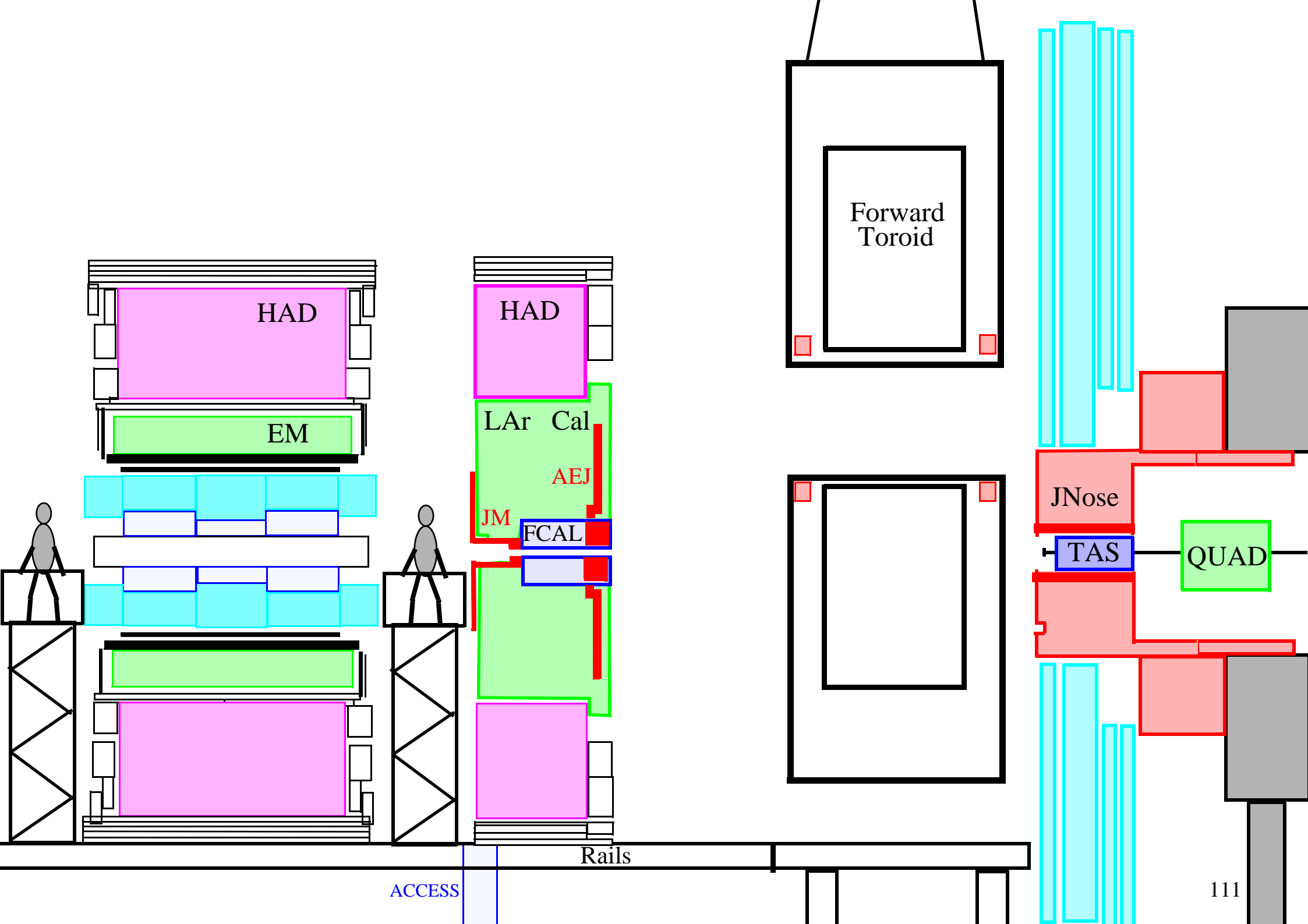

HAD

EM

HAD

LAr Cal

AEJ

JM

FCAL

Forward
Toroid

JNose

TAS

QUAD

Rails

ACCESS

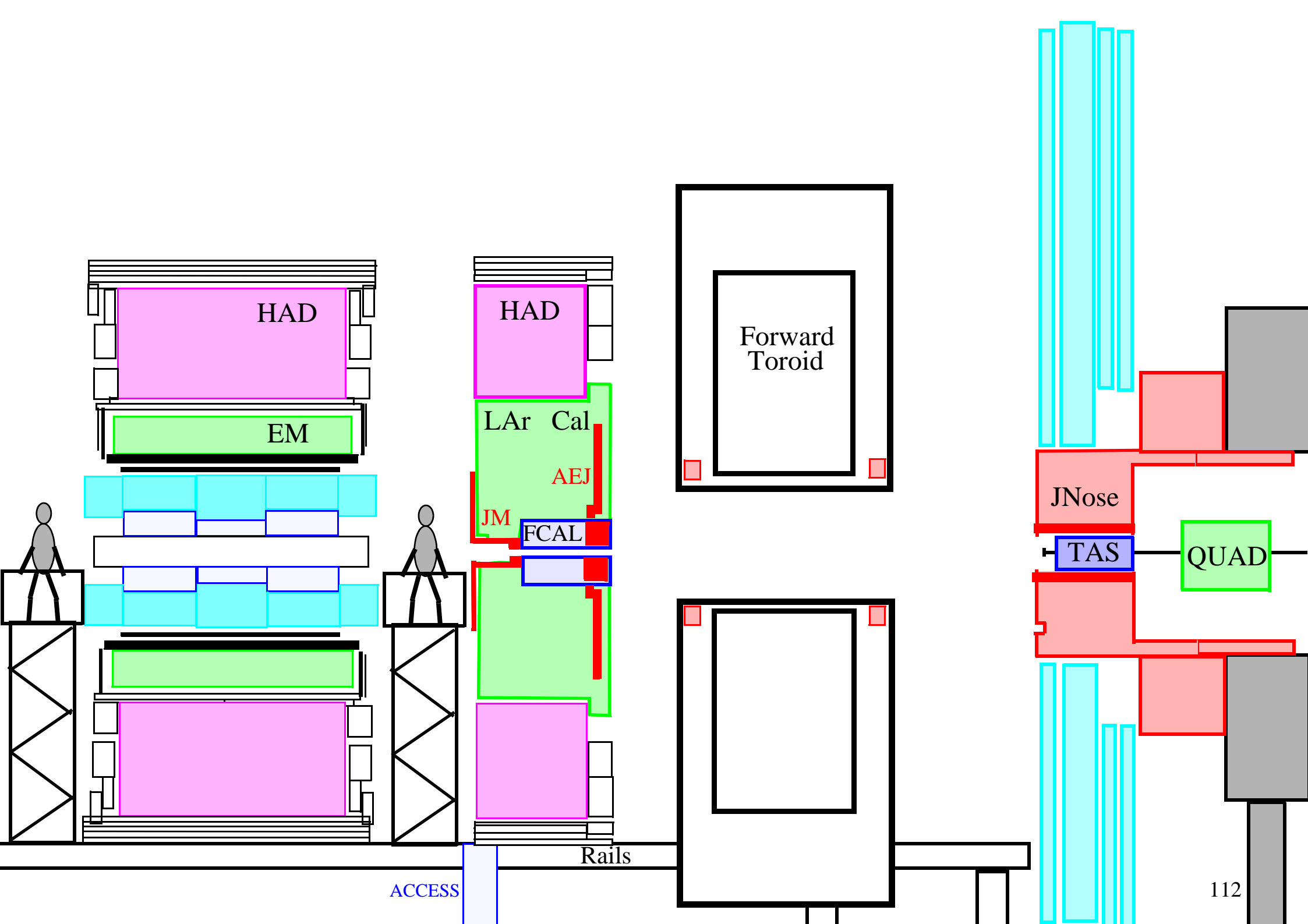

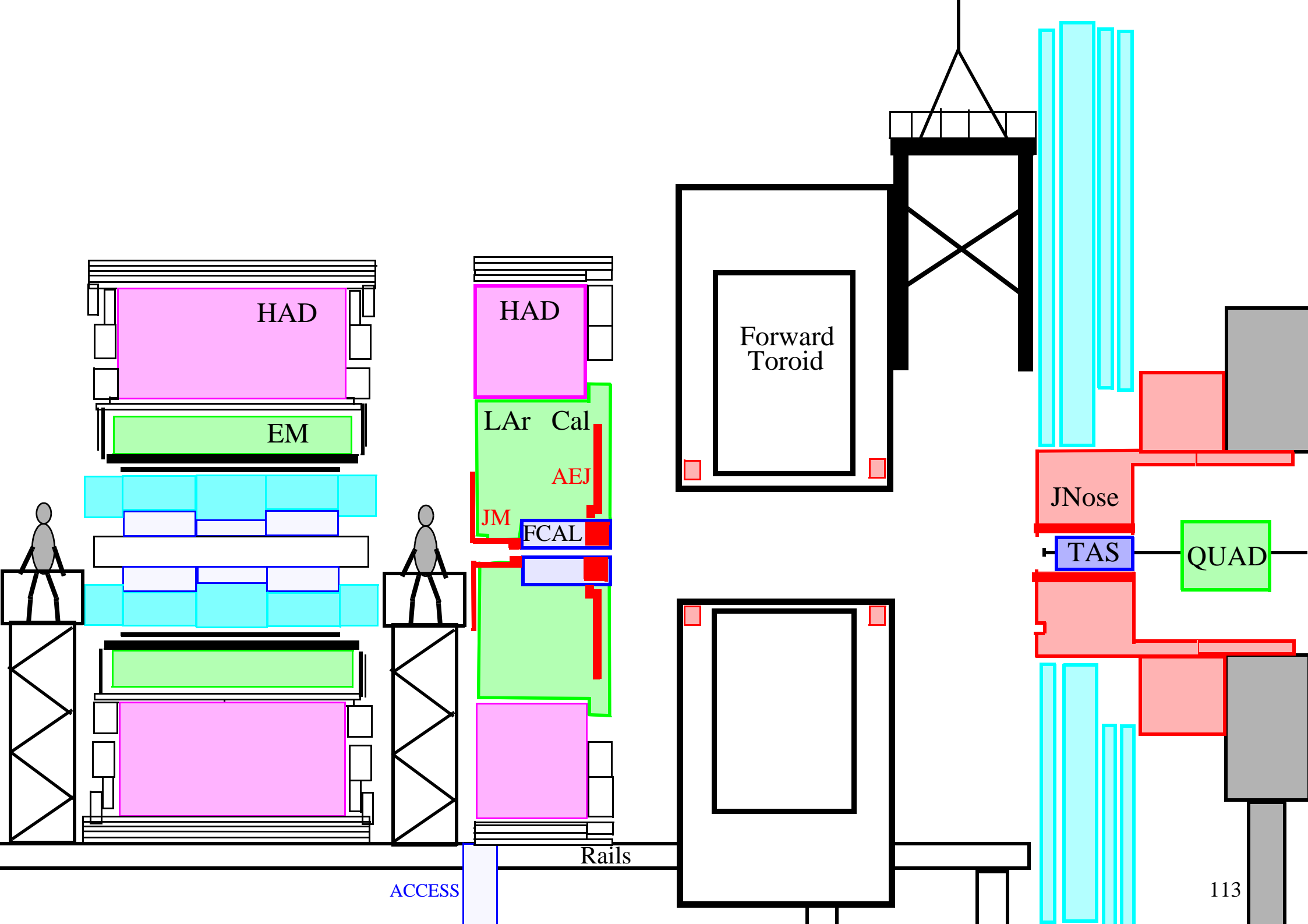

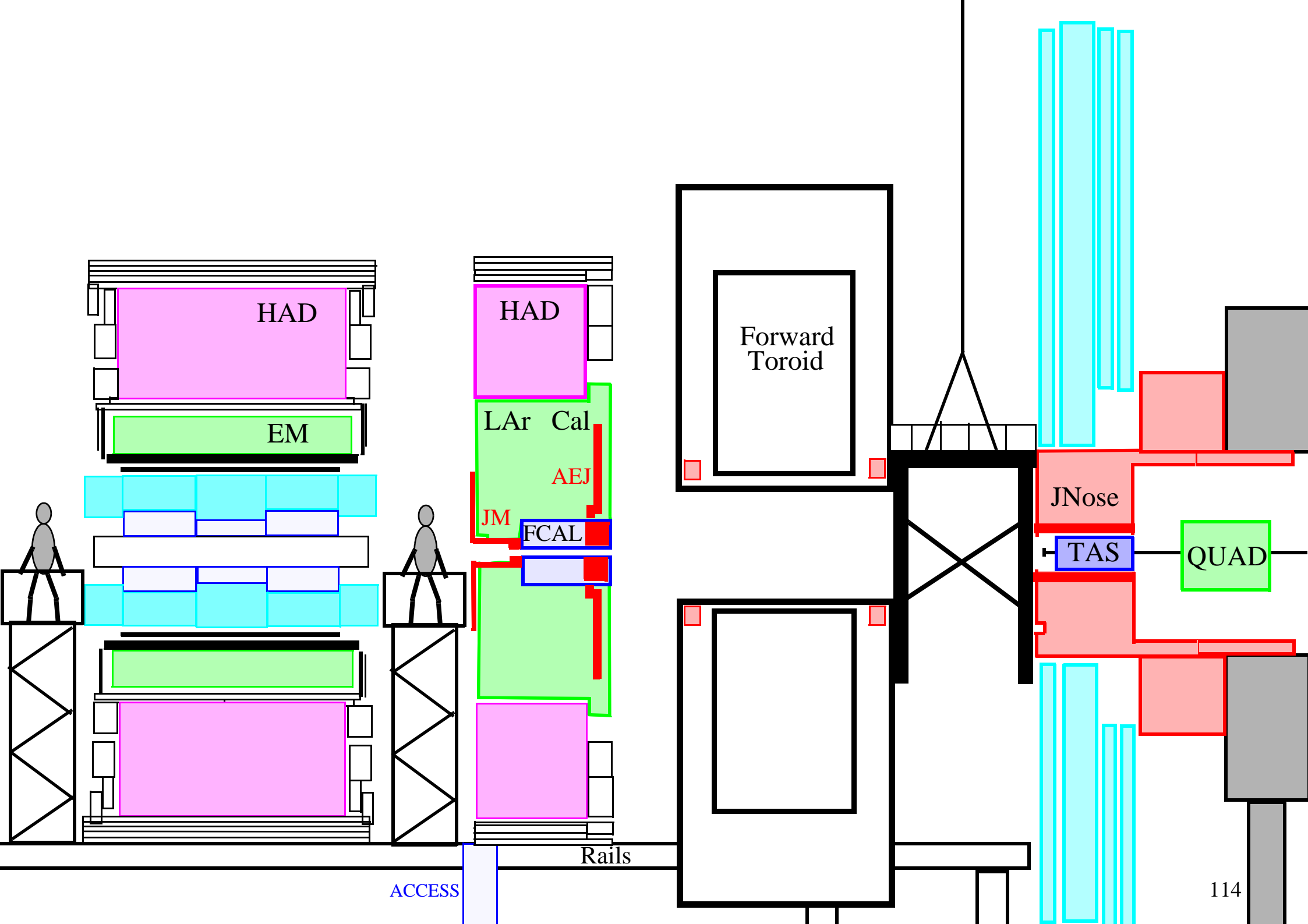

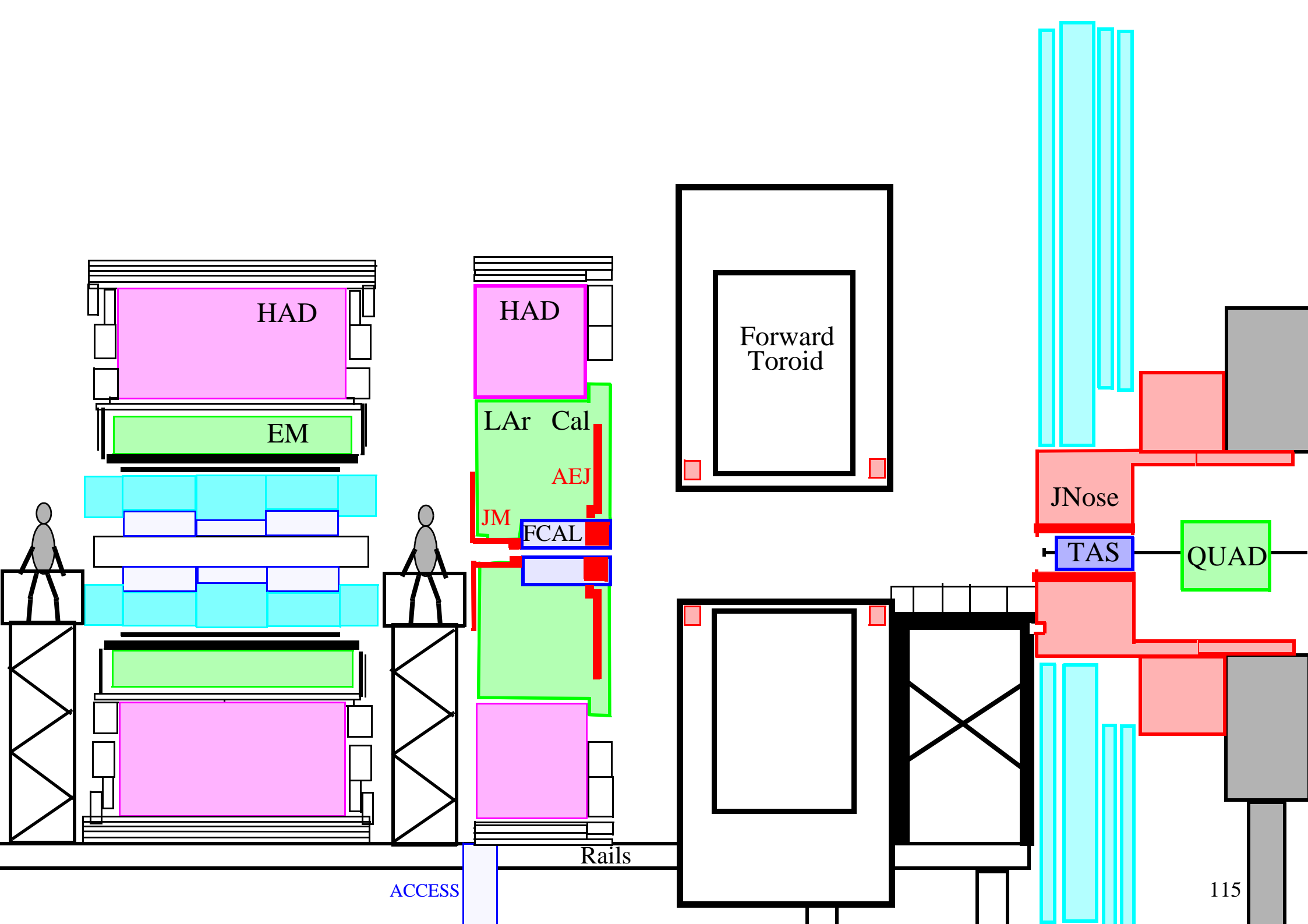



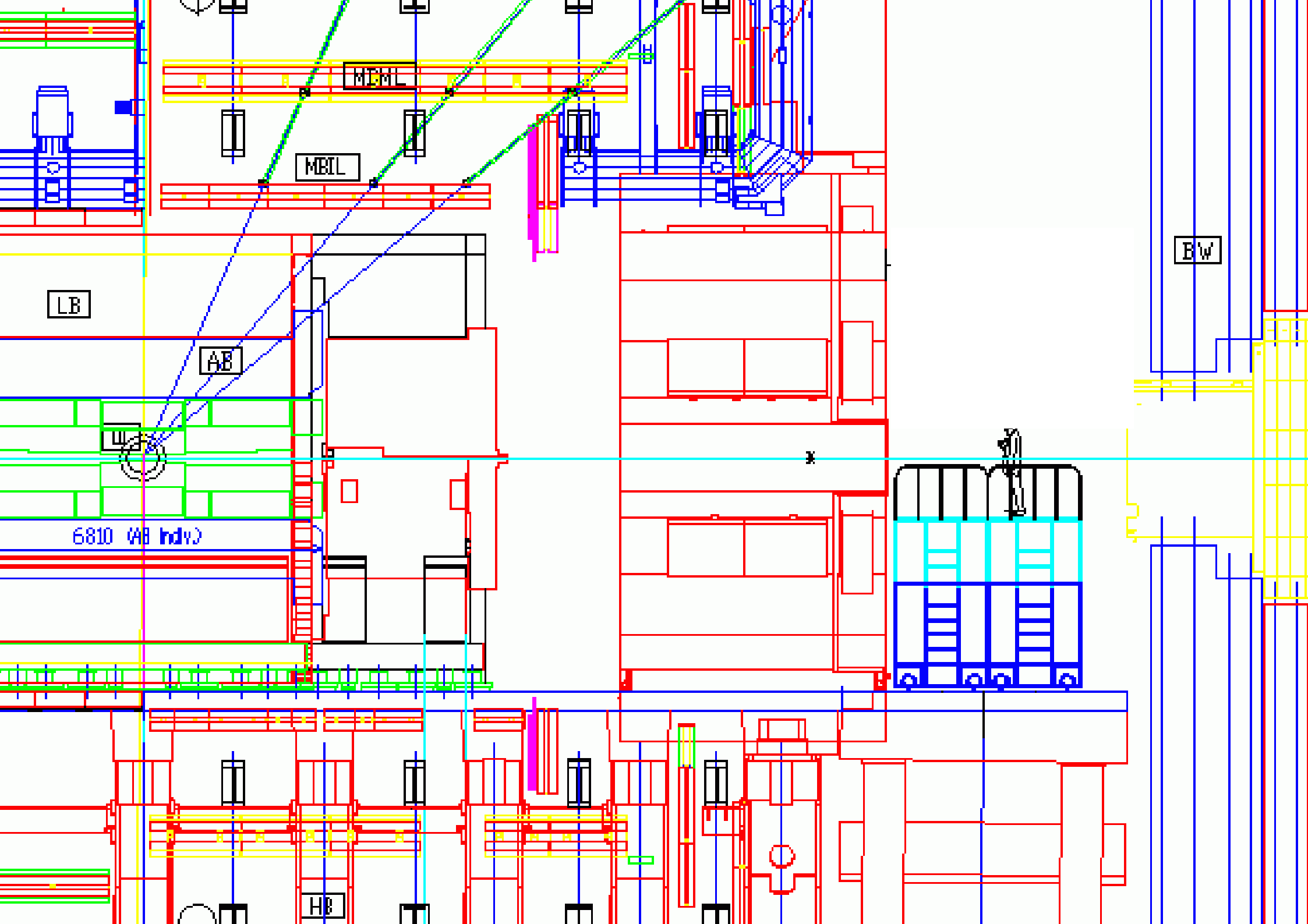

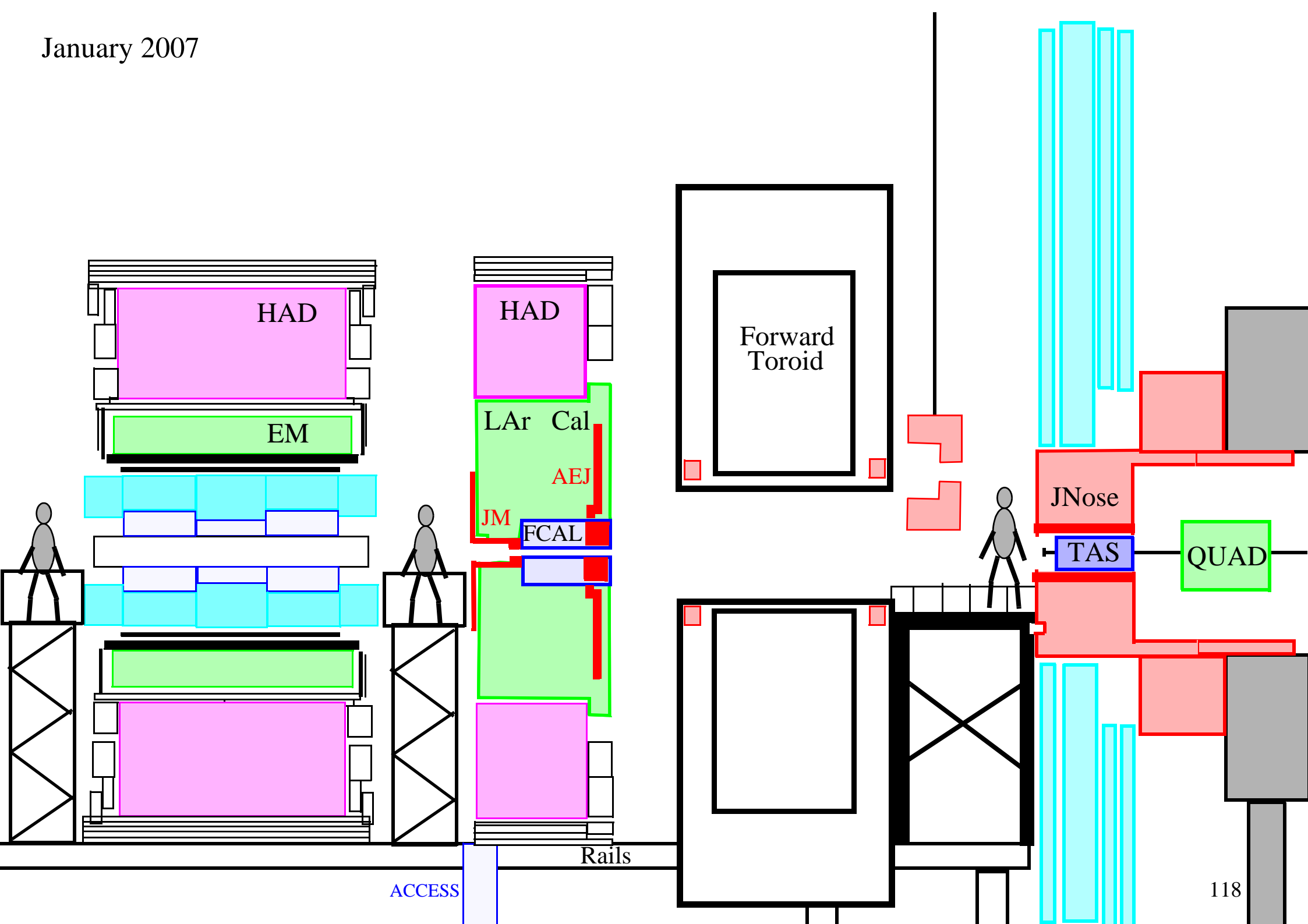

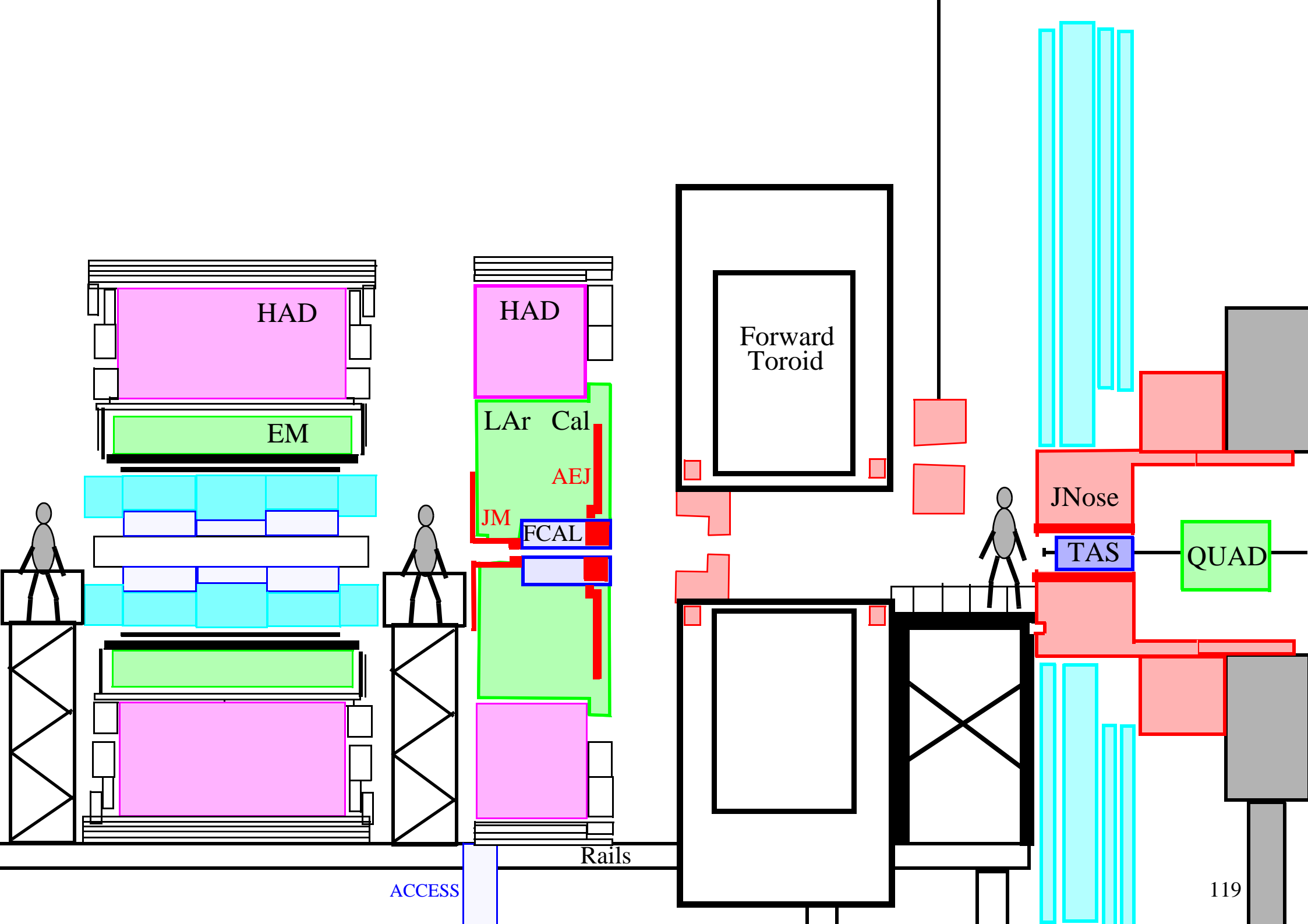

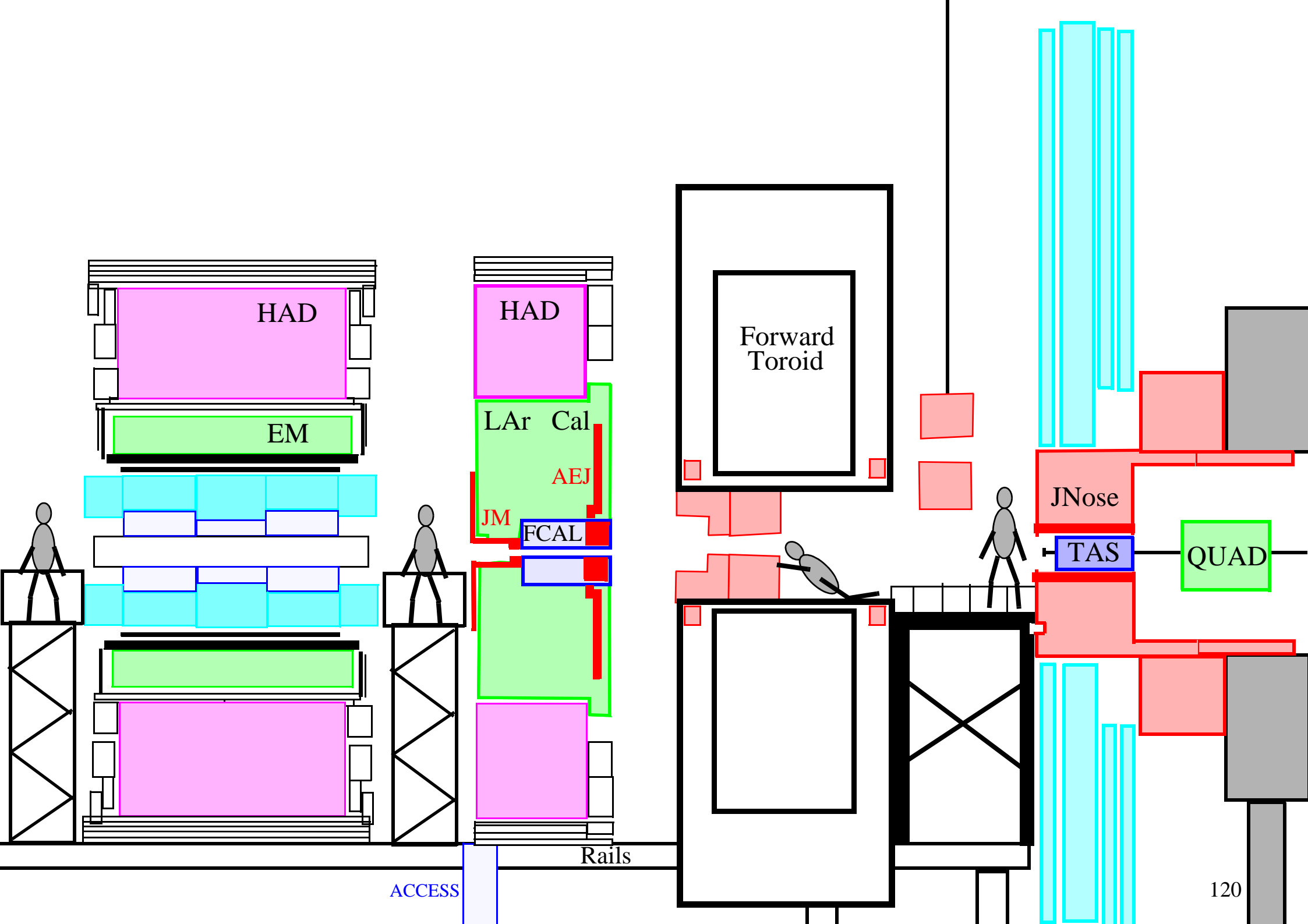

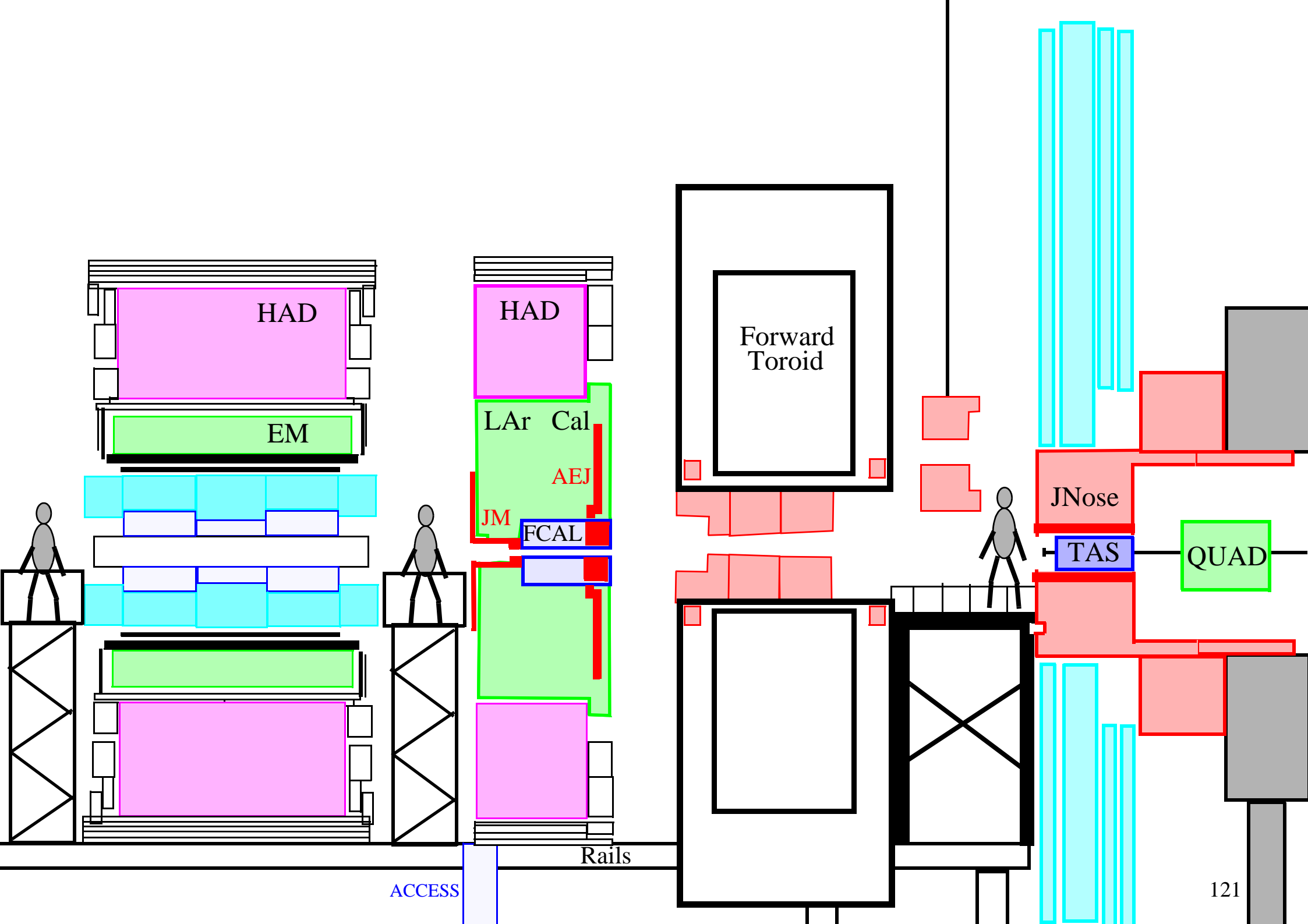

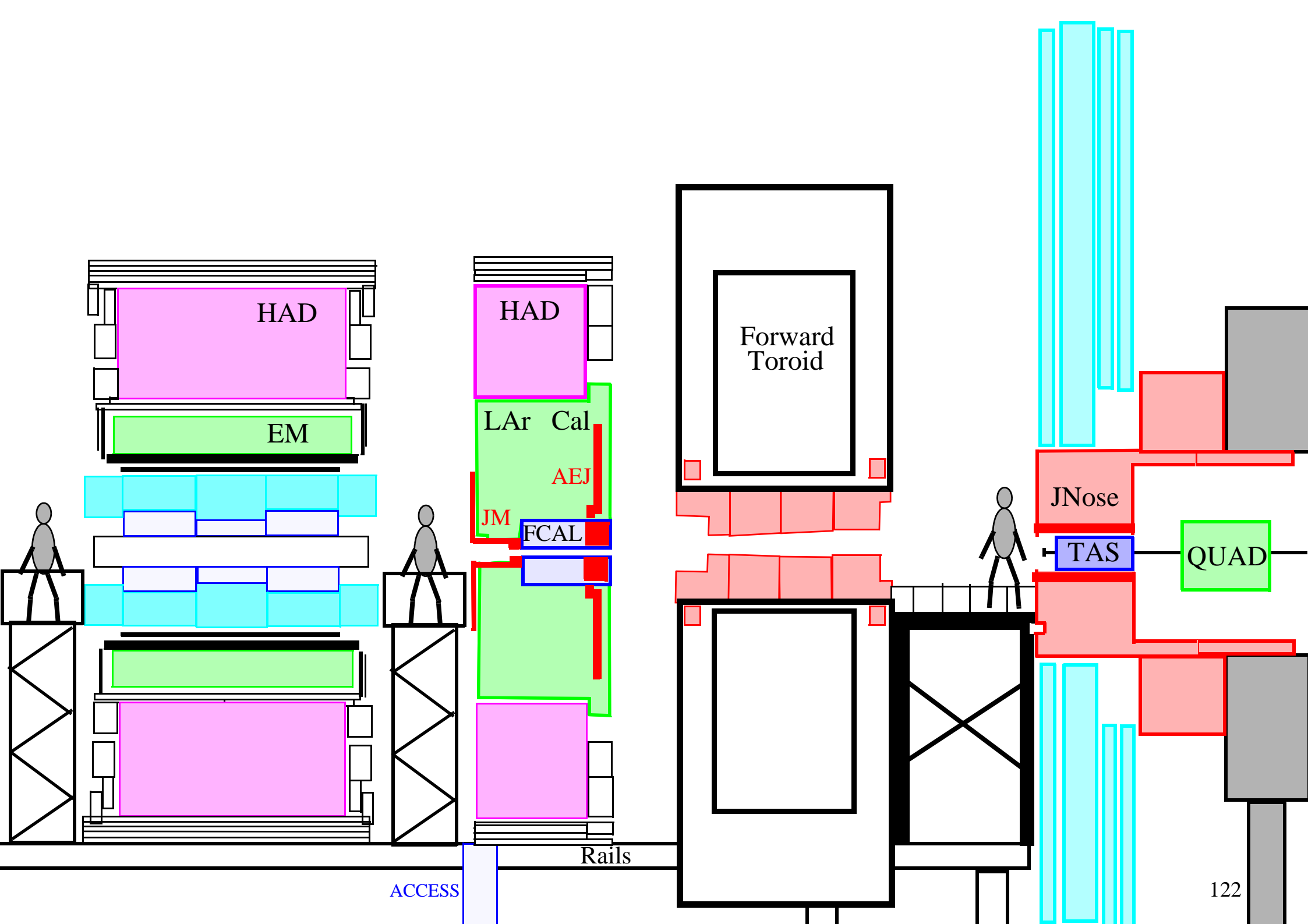

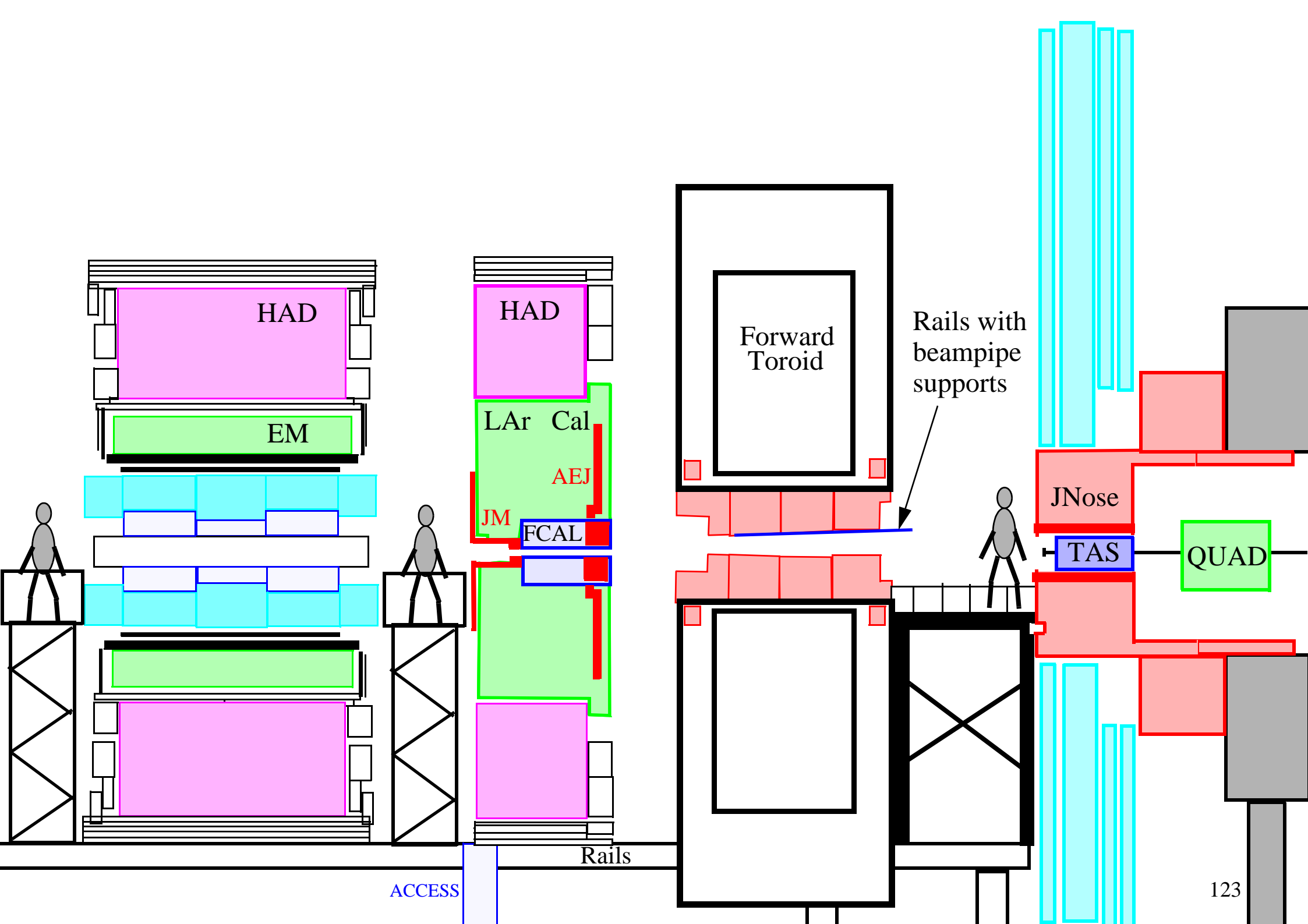

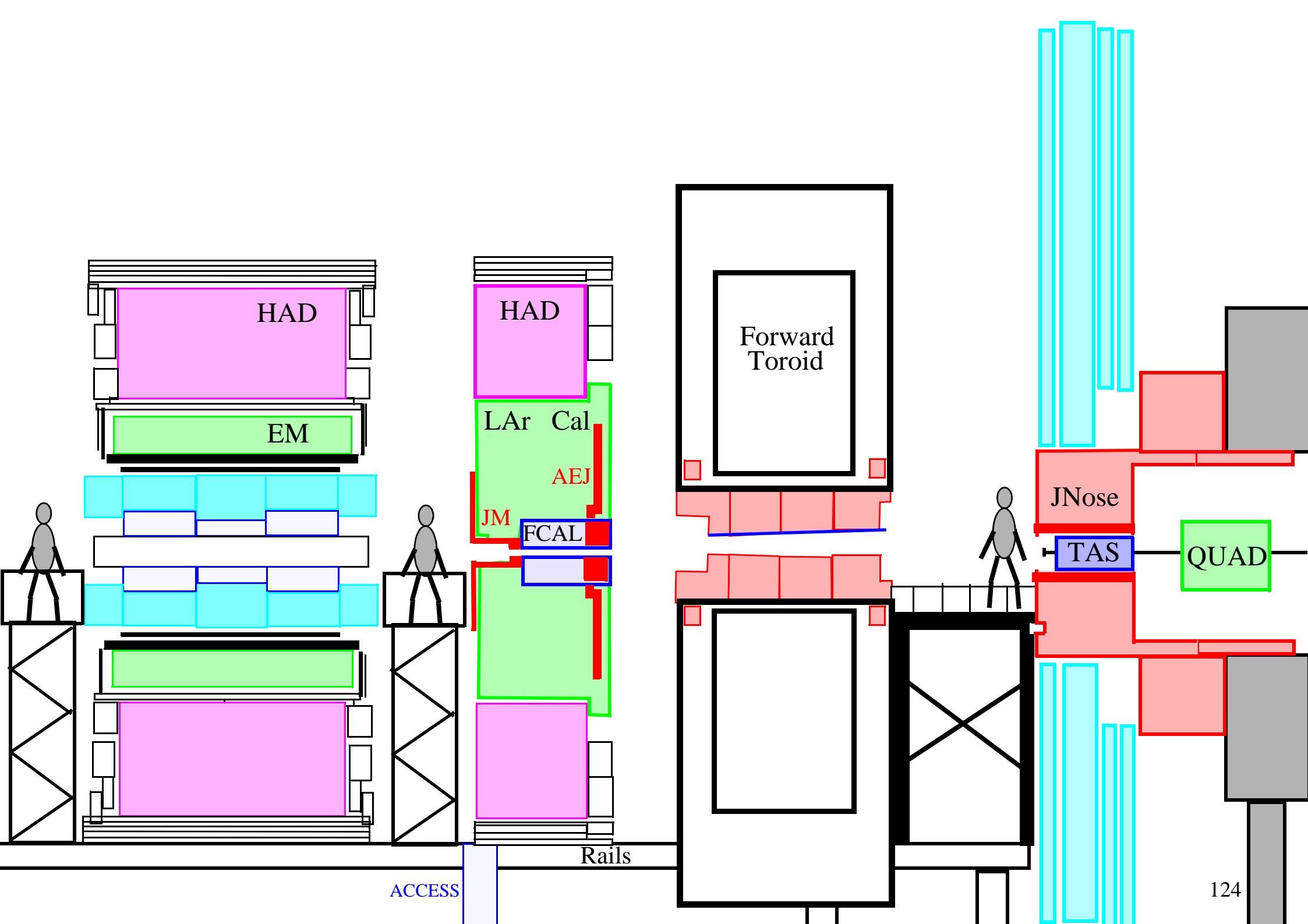

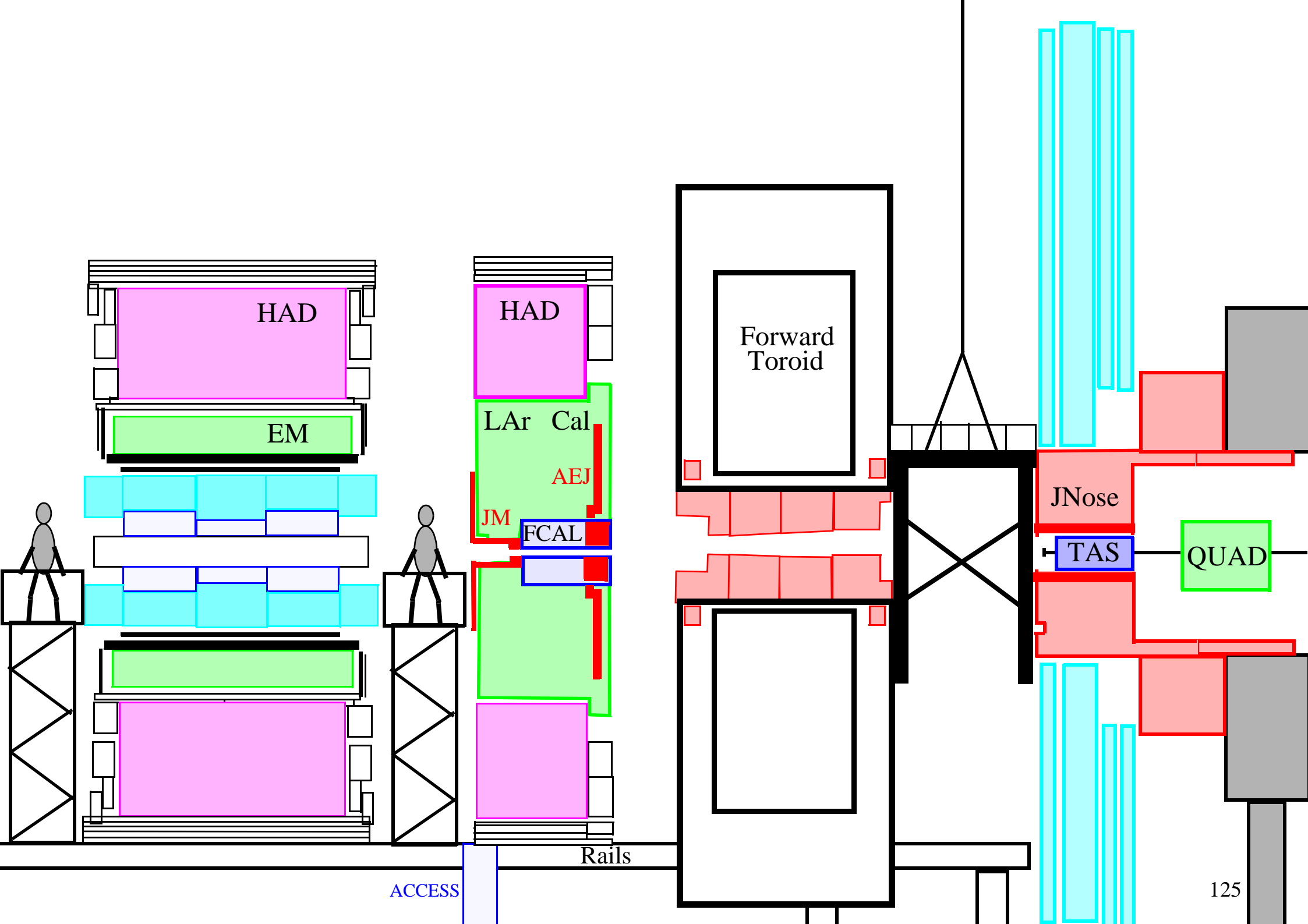

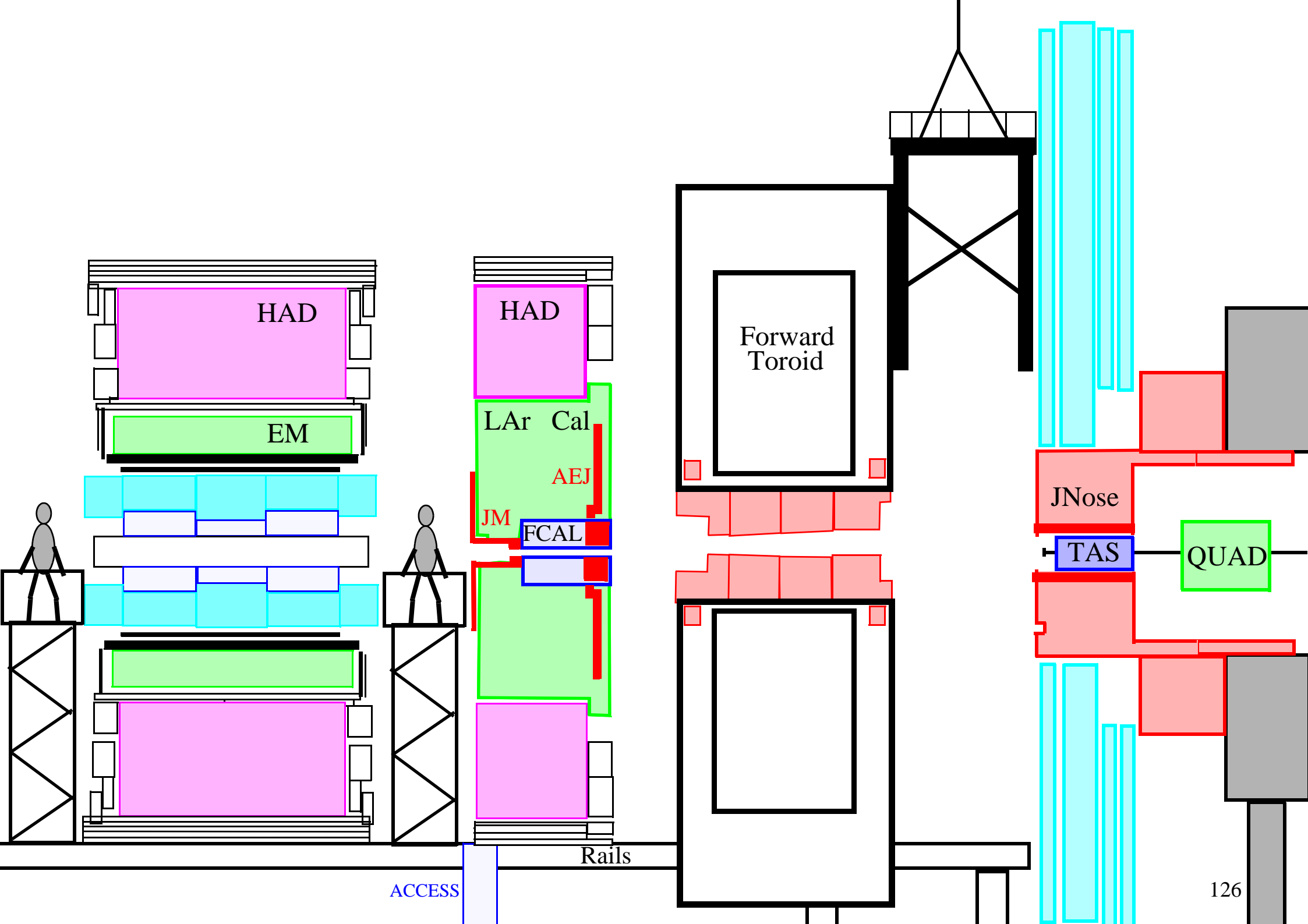

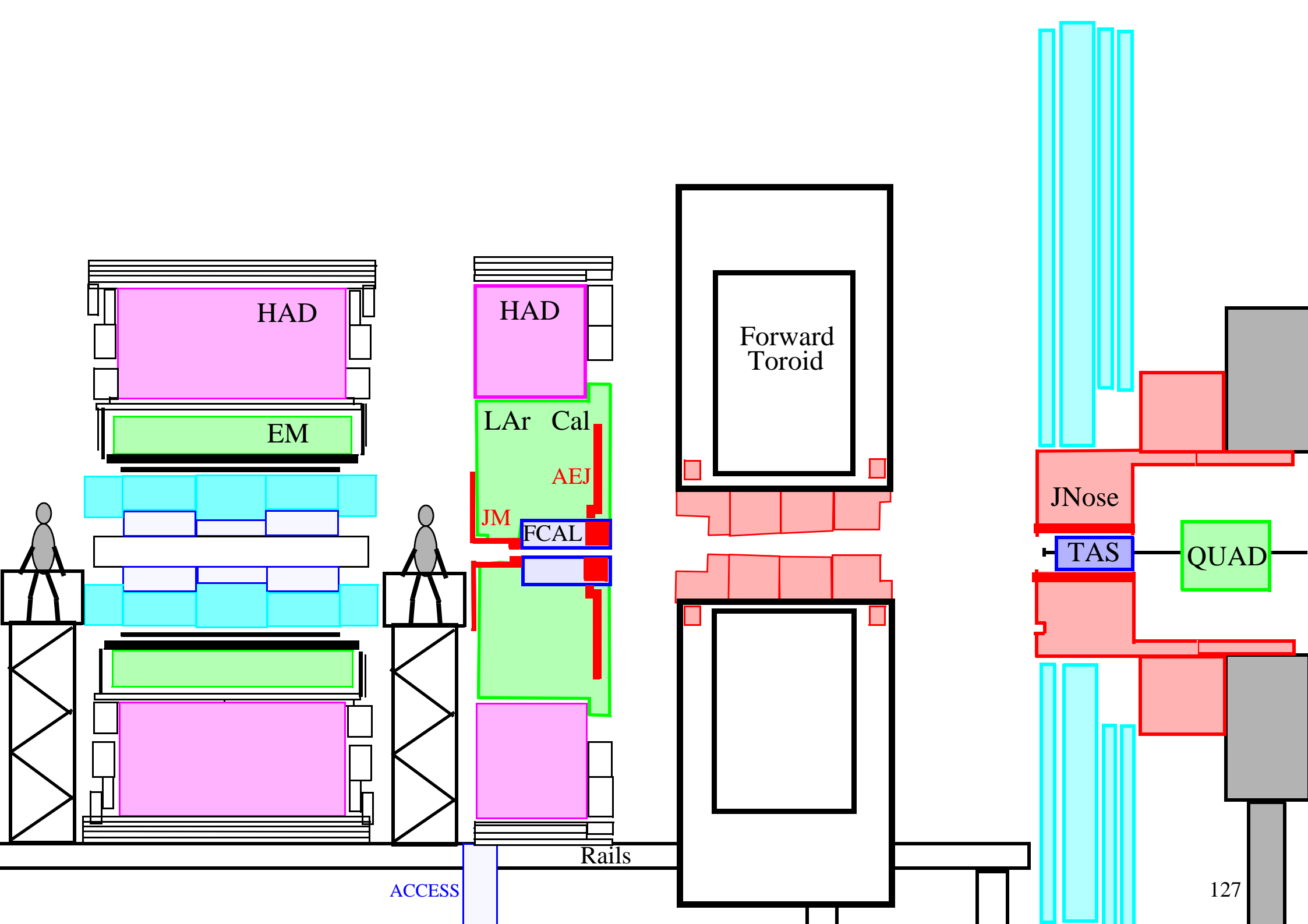

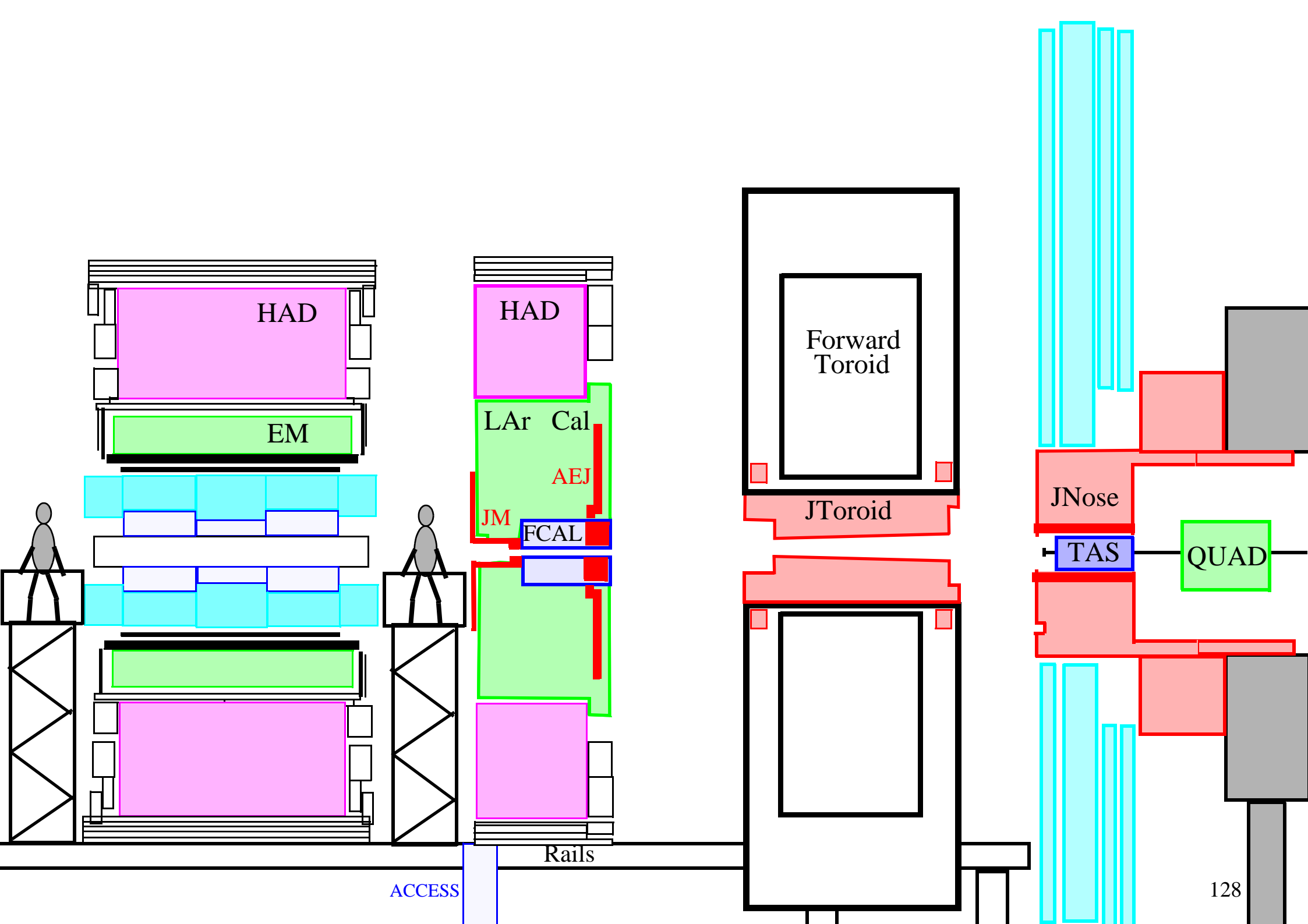

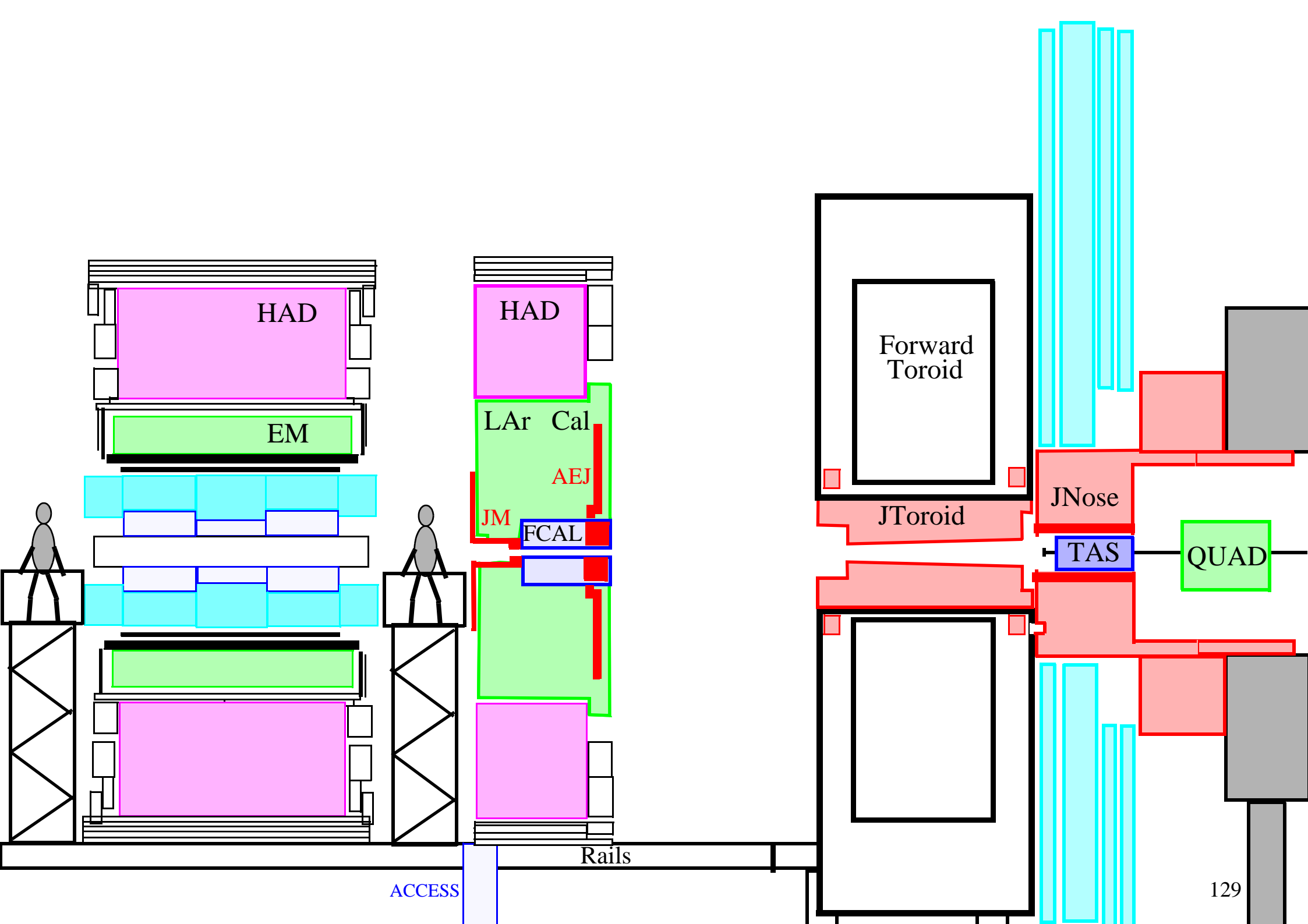

February 2007

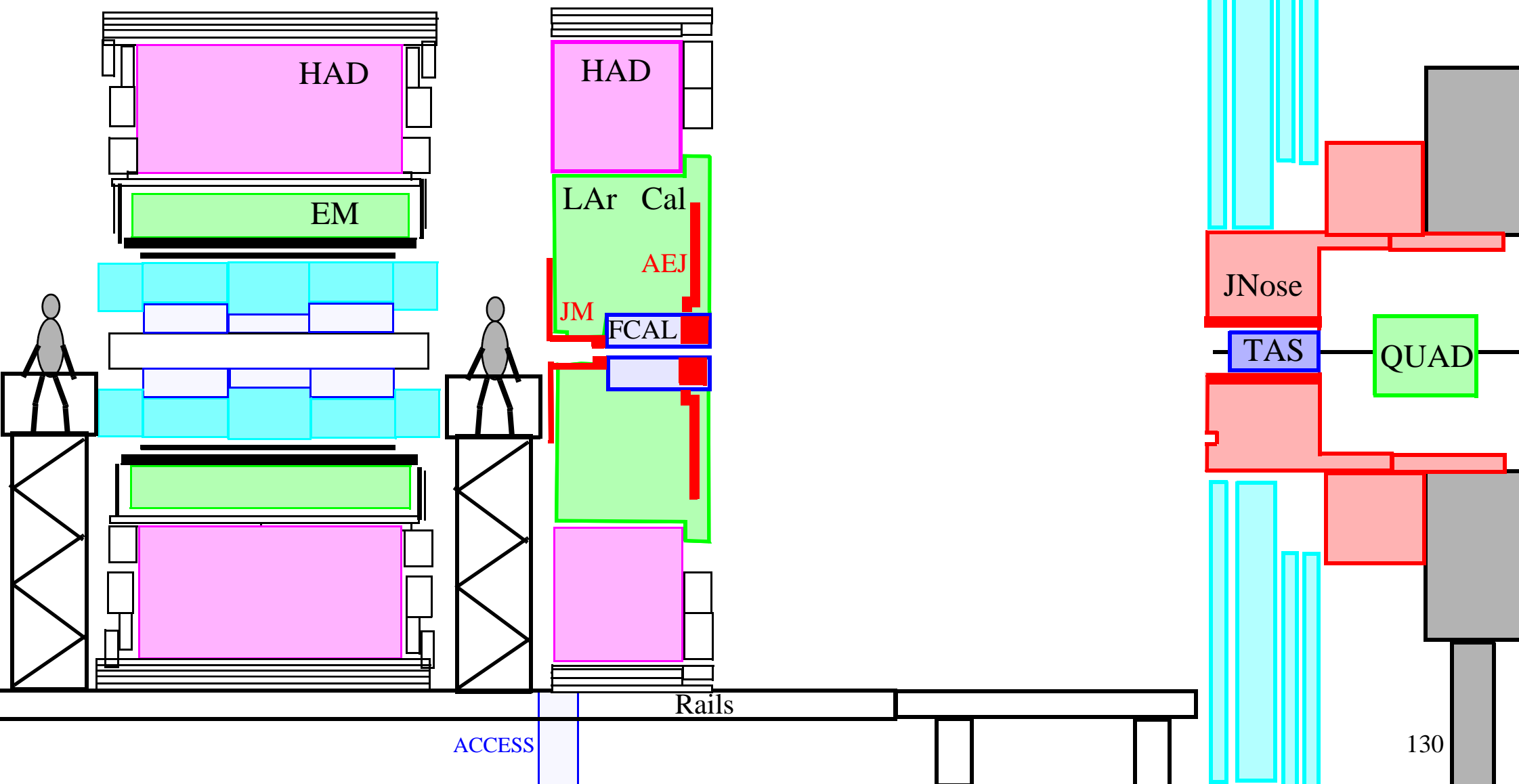

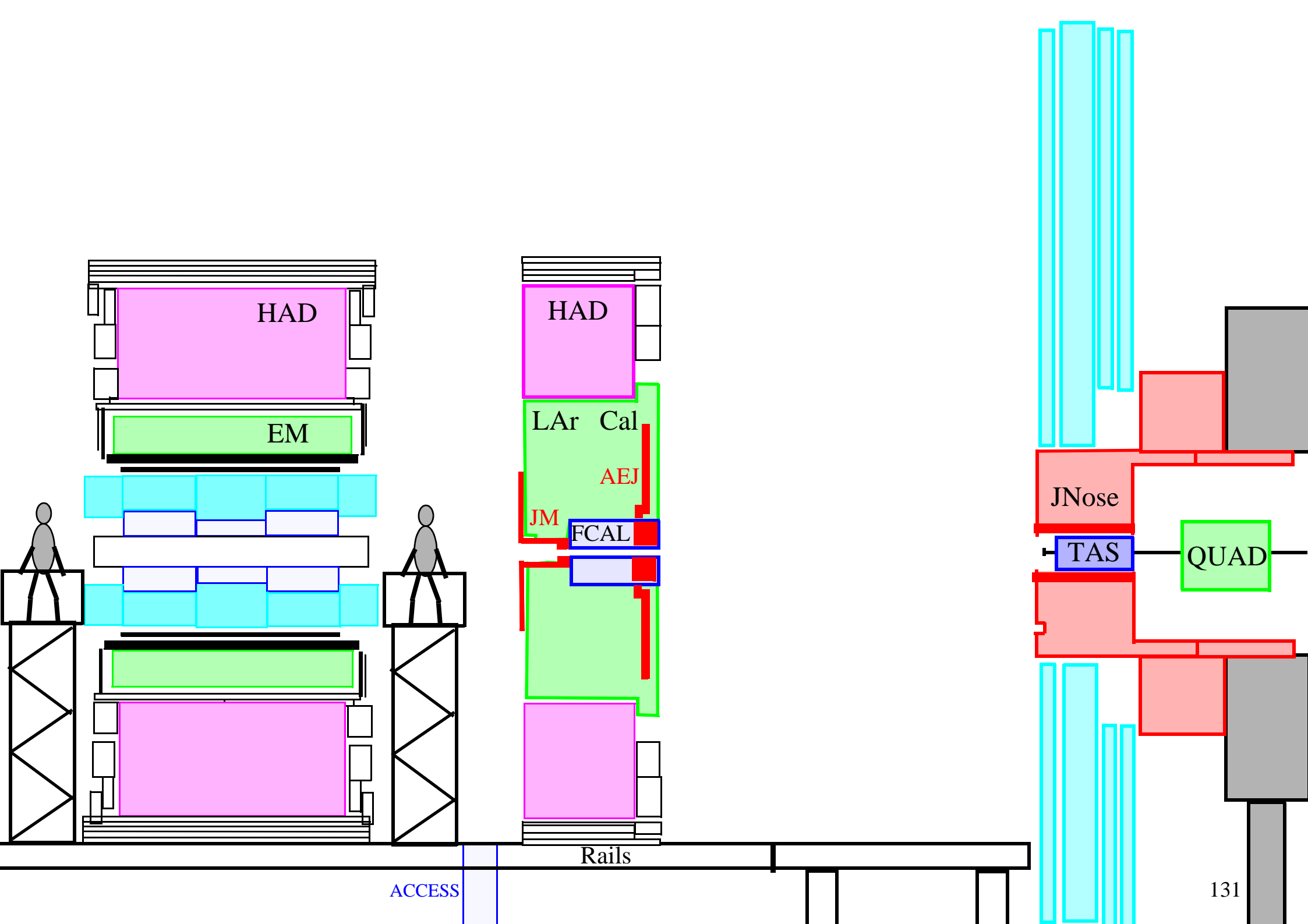

HAD

EM

HAD

LAr Cal

AEJ

JM

FCAL

JNose

TAS

QUAD

Rails

ACCESS

131

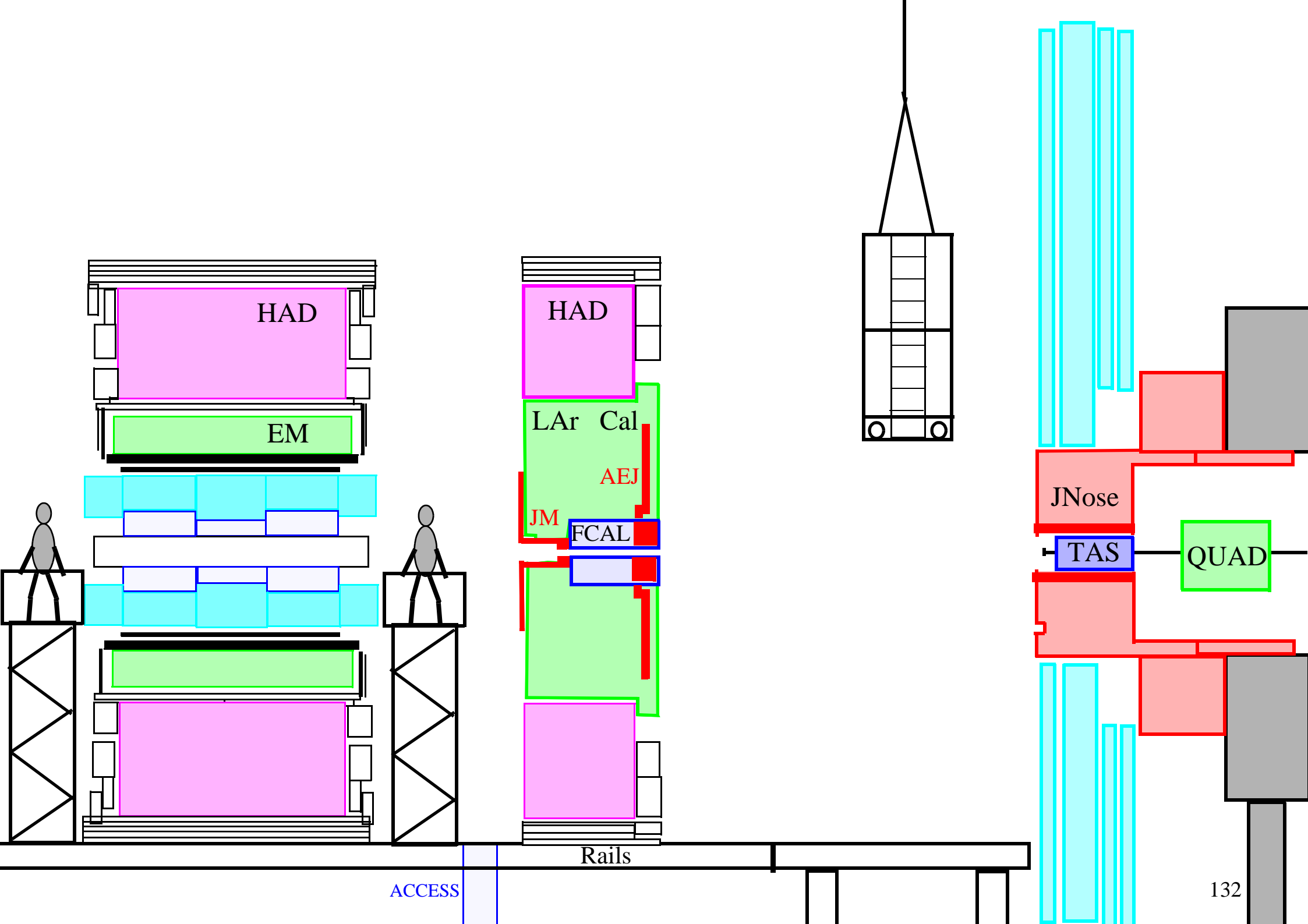

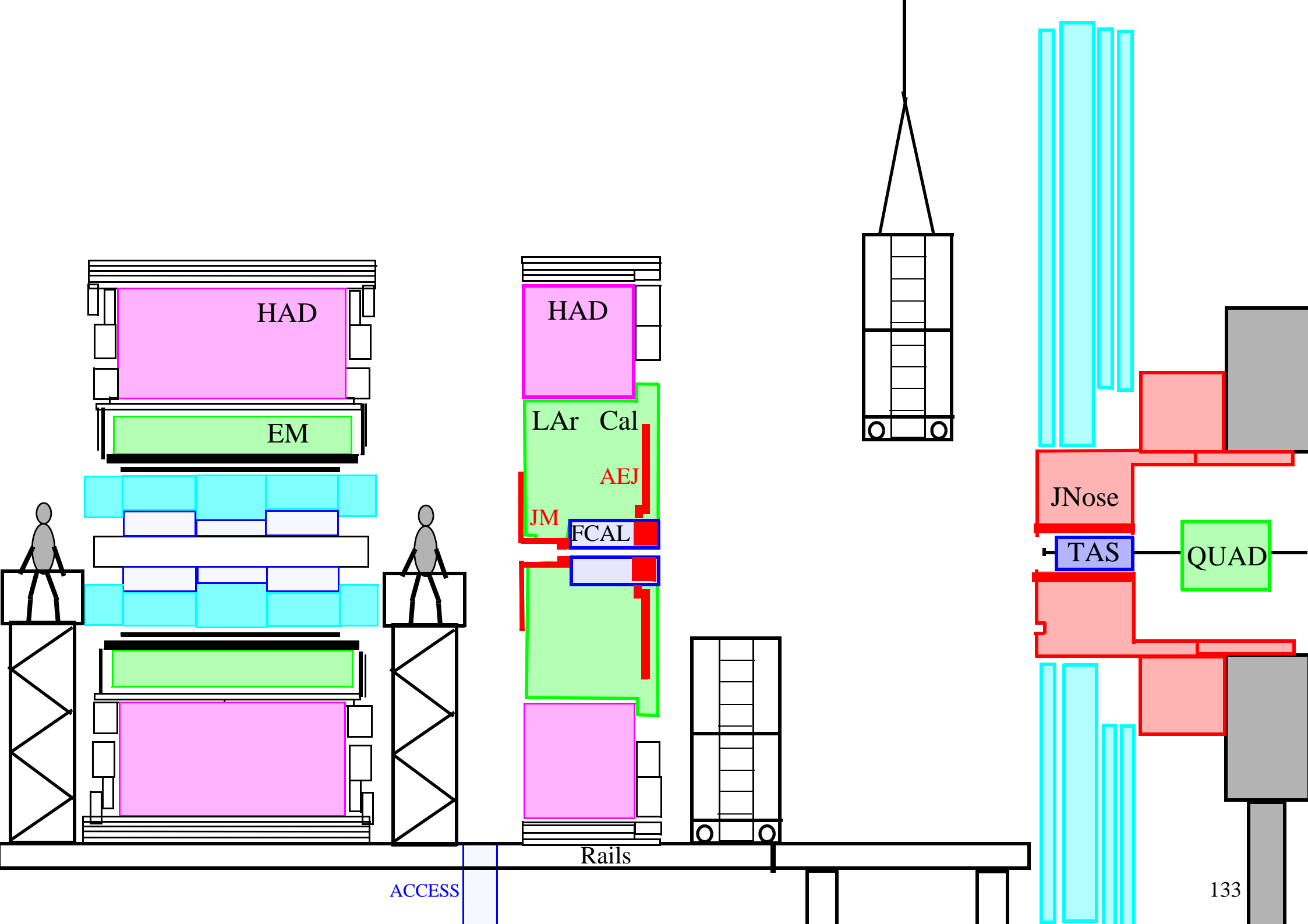

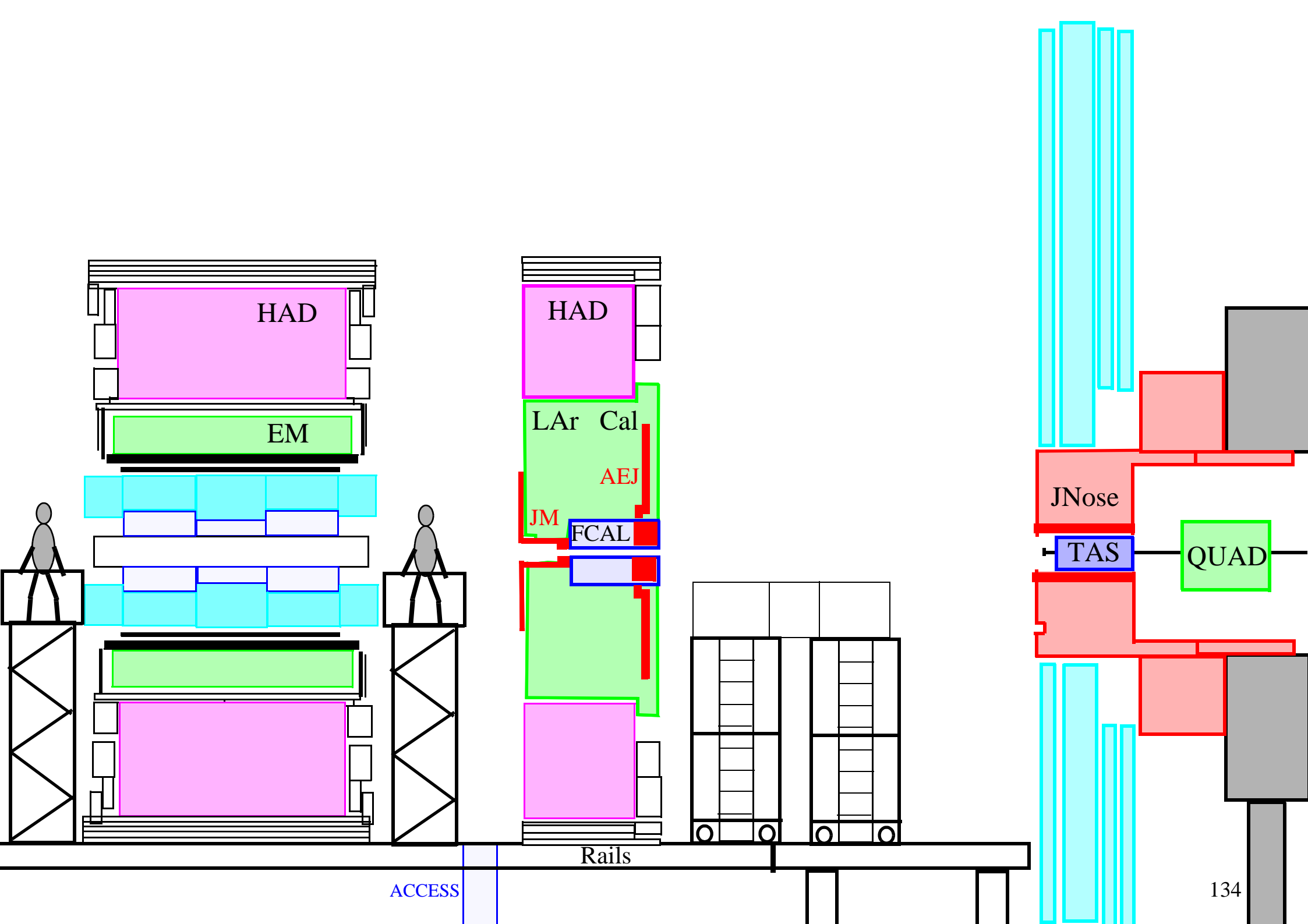

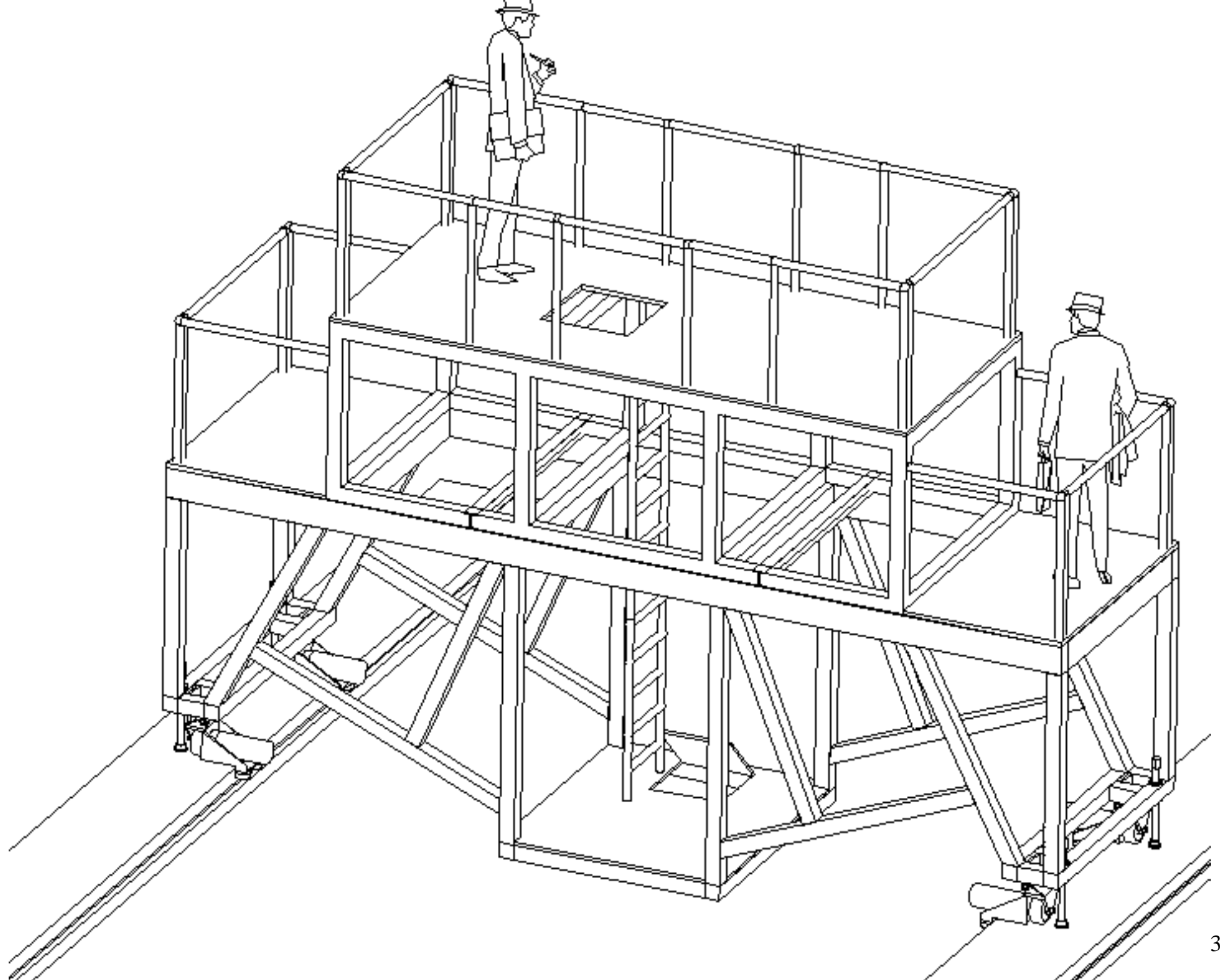

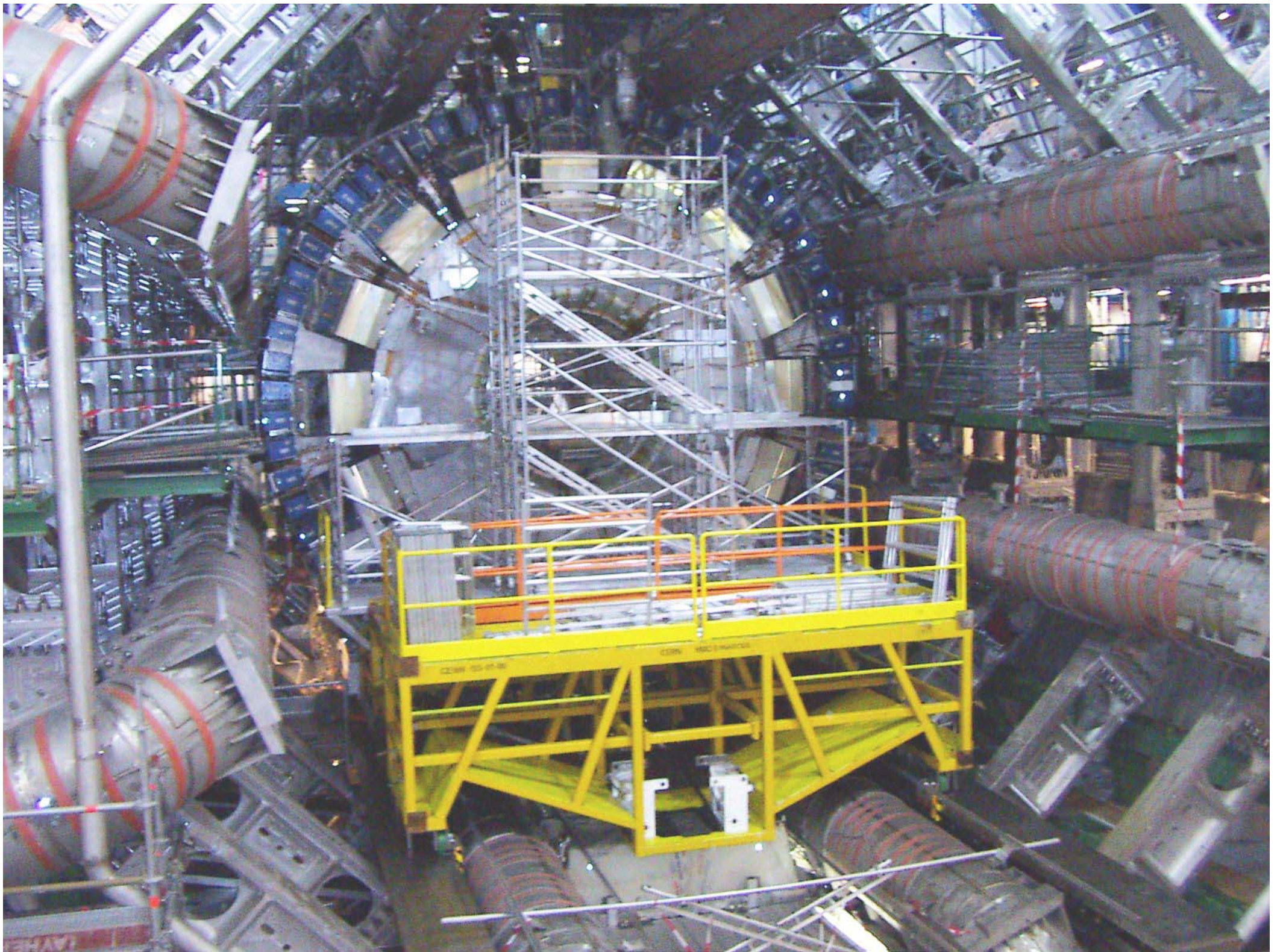

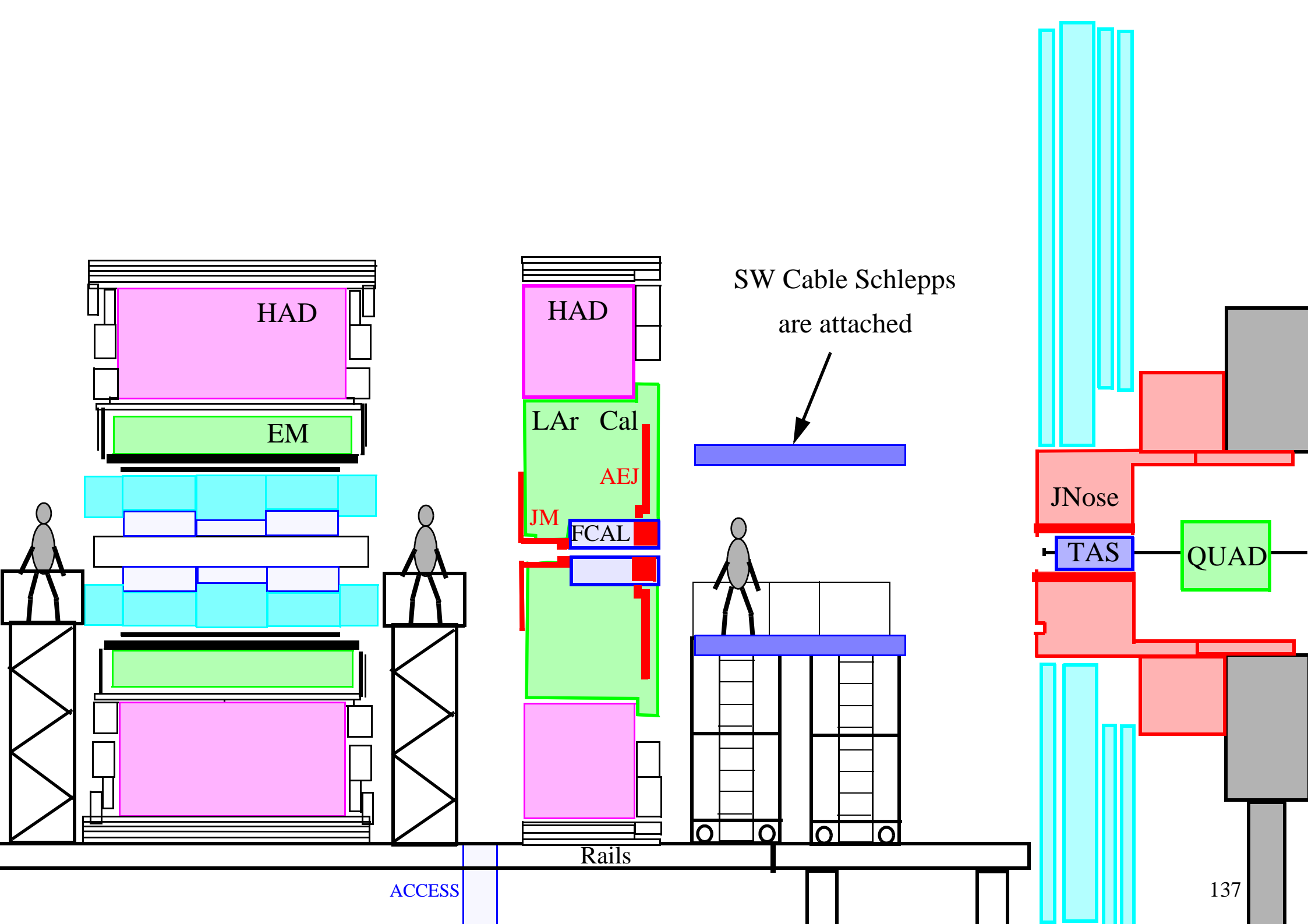

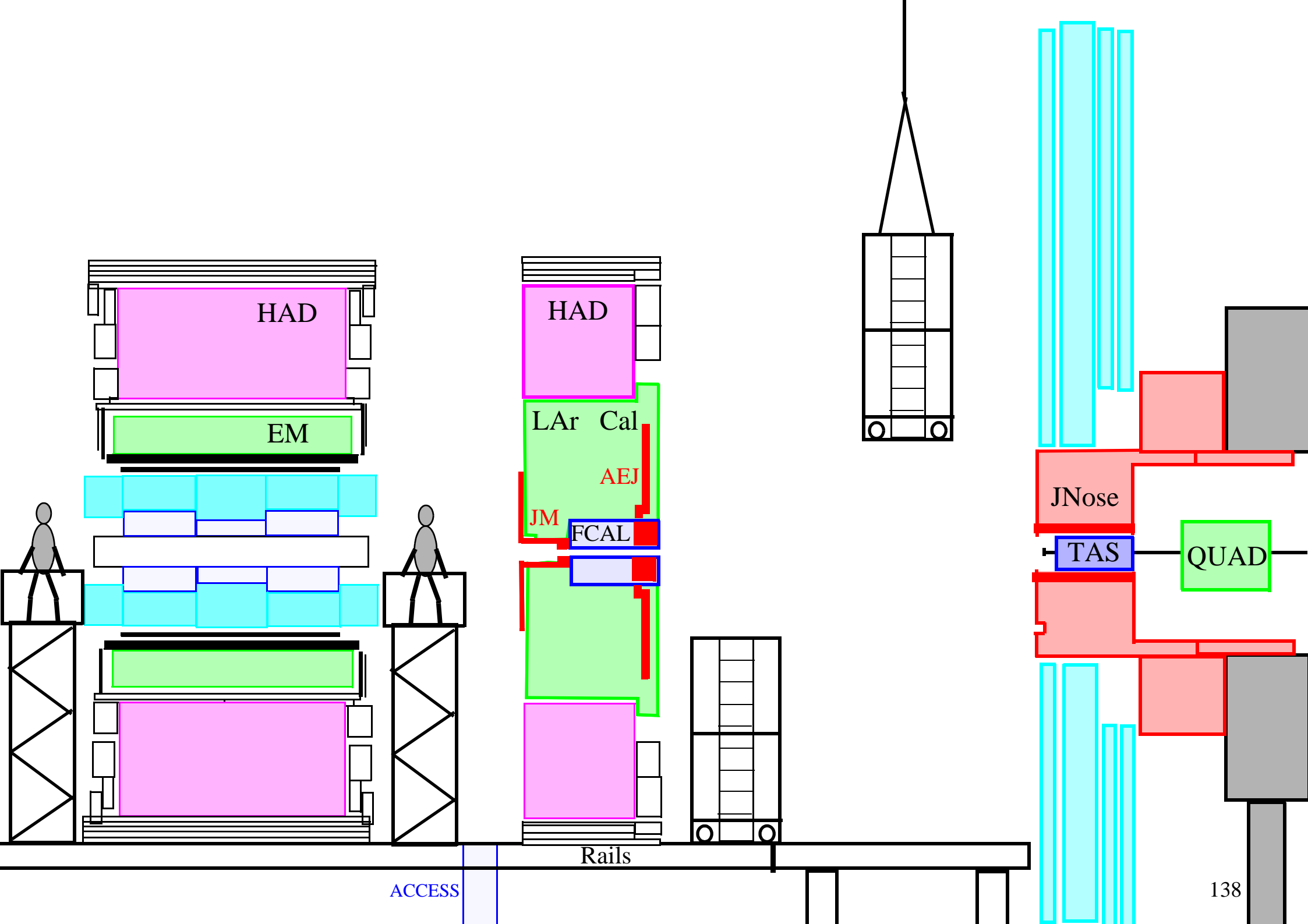

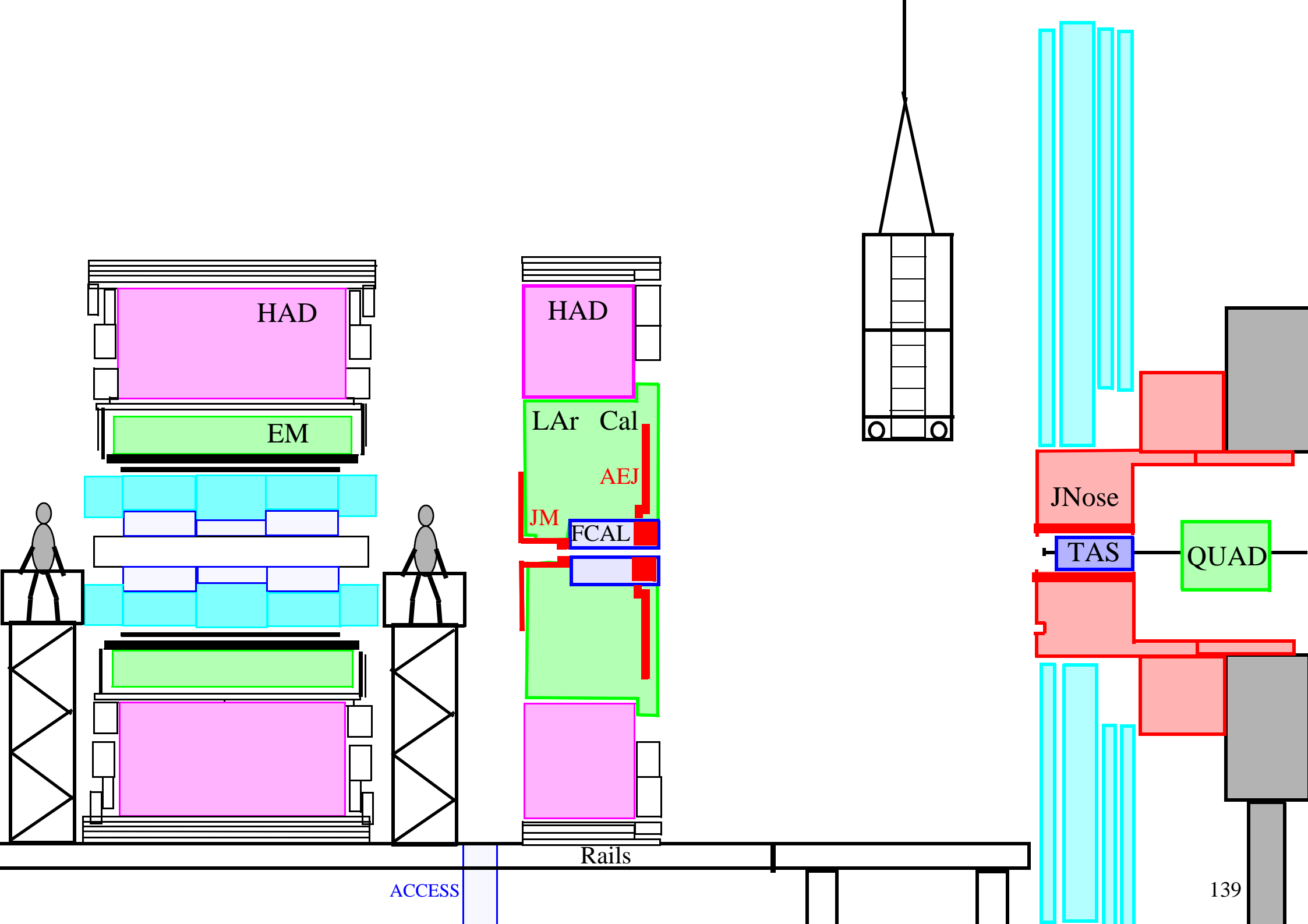

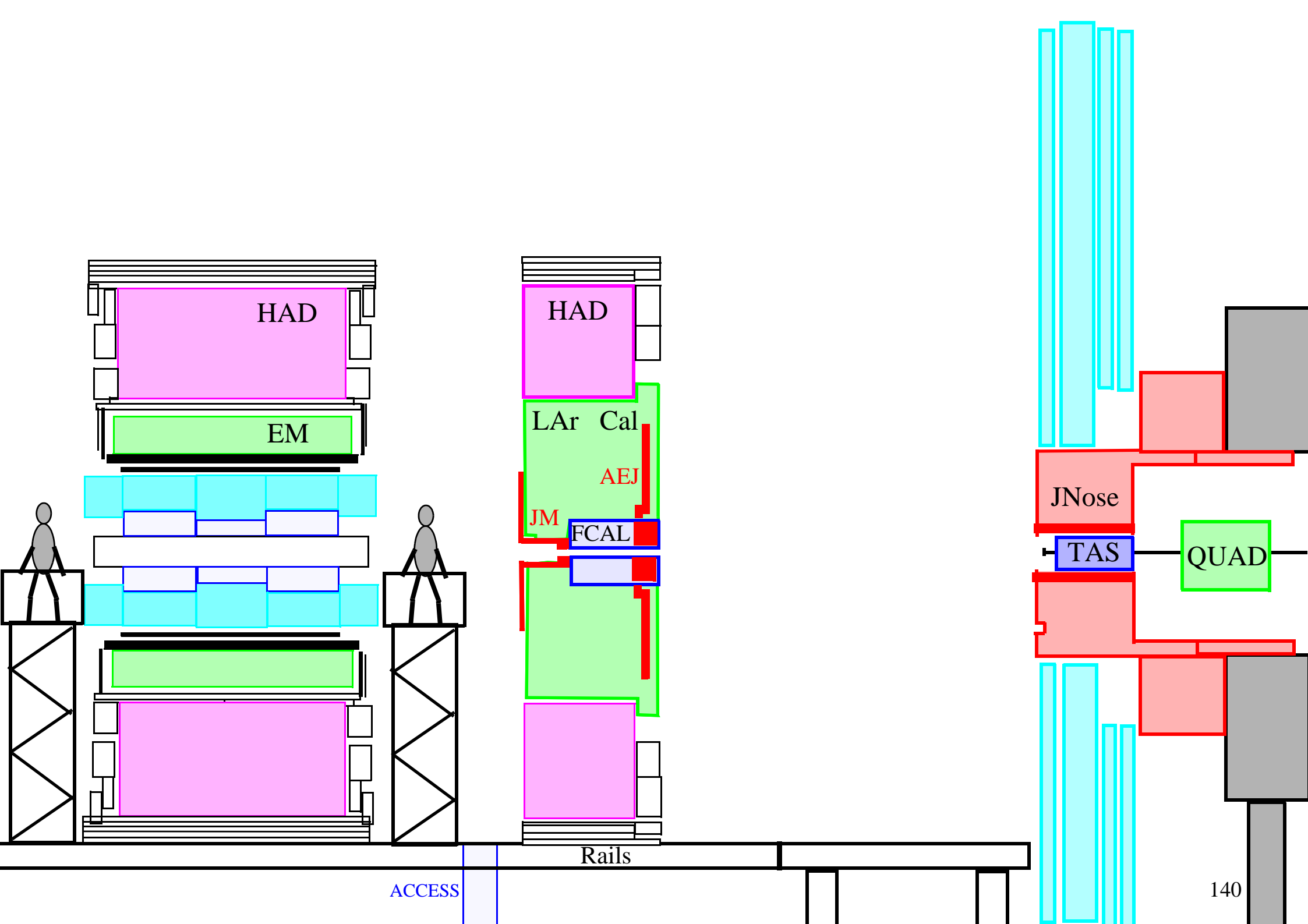

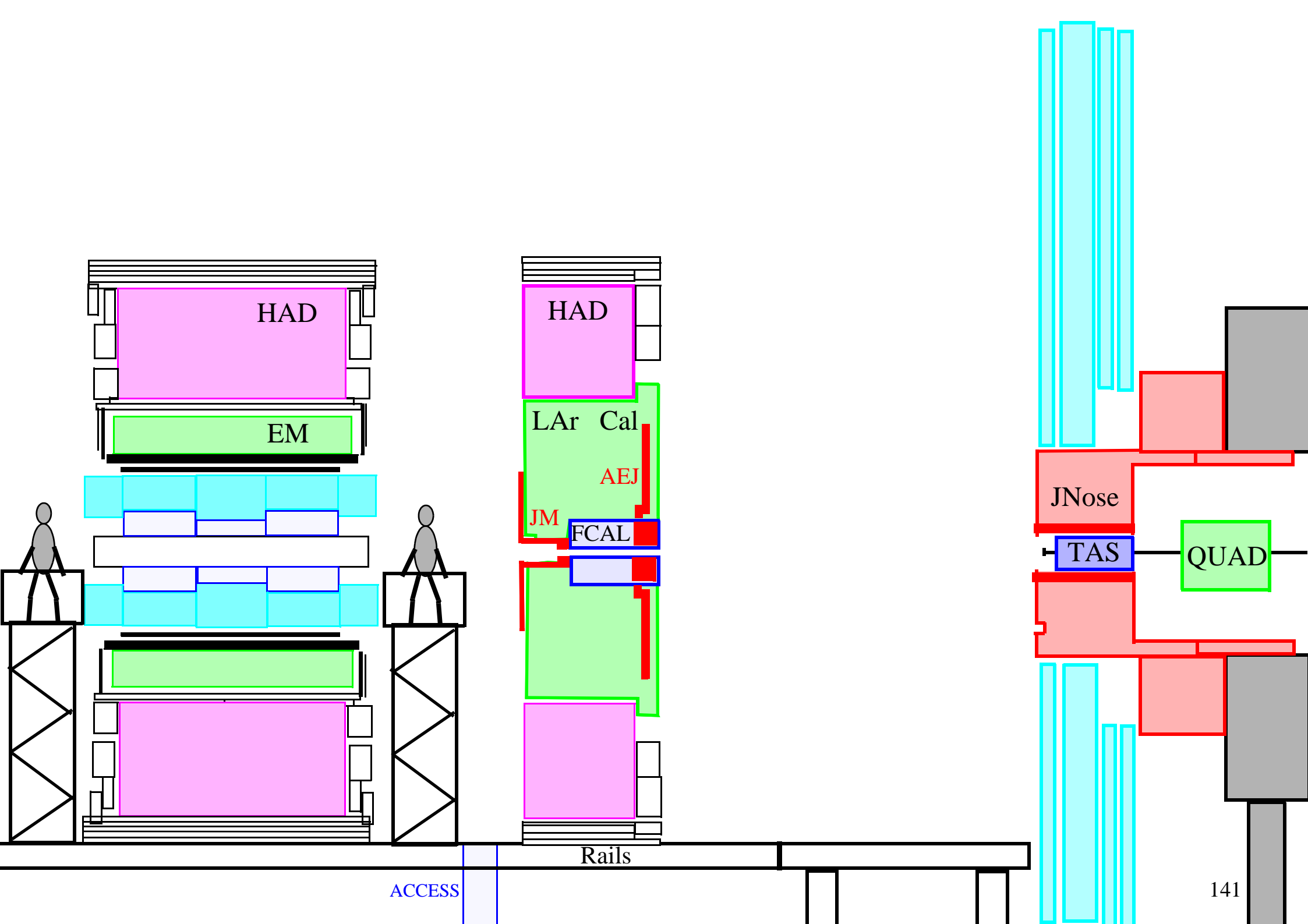

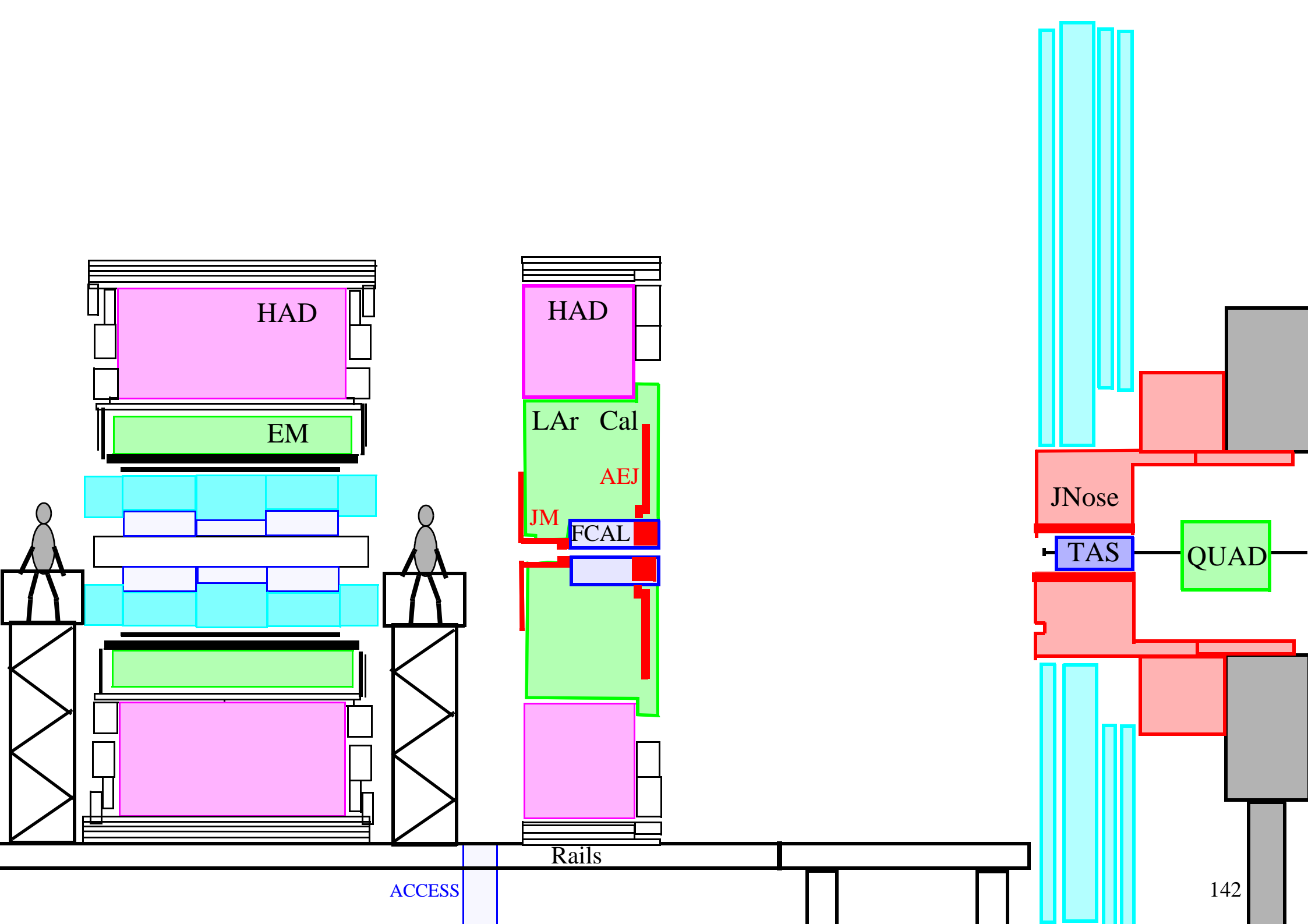

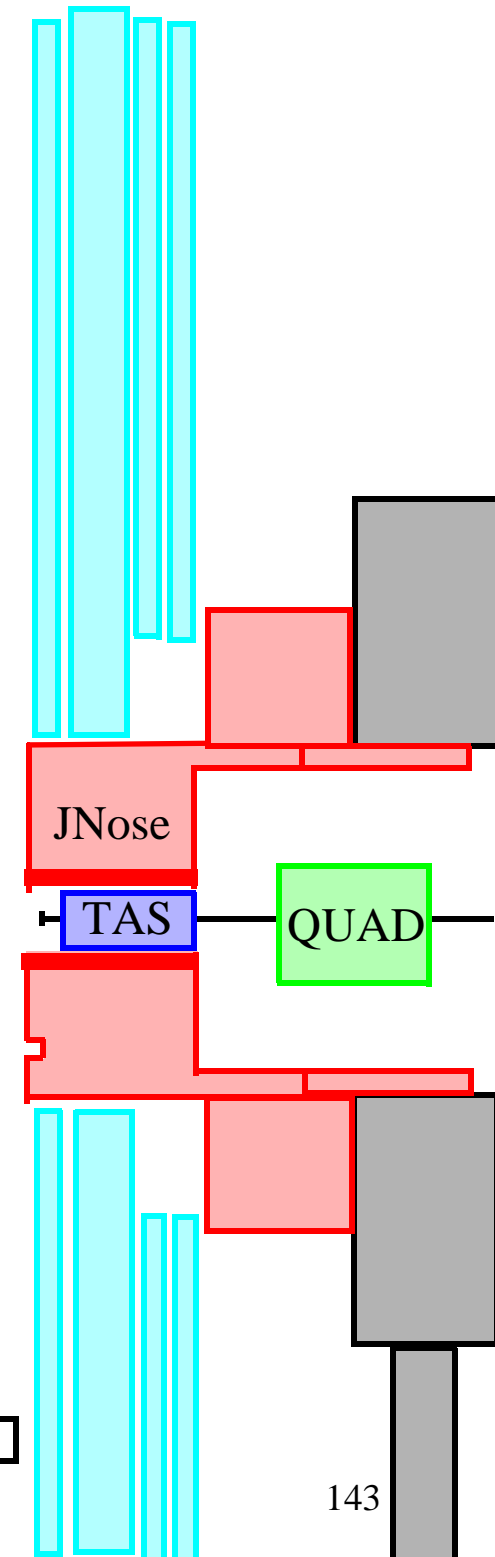
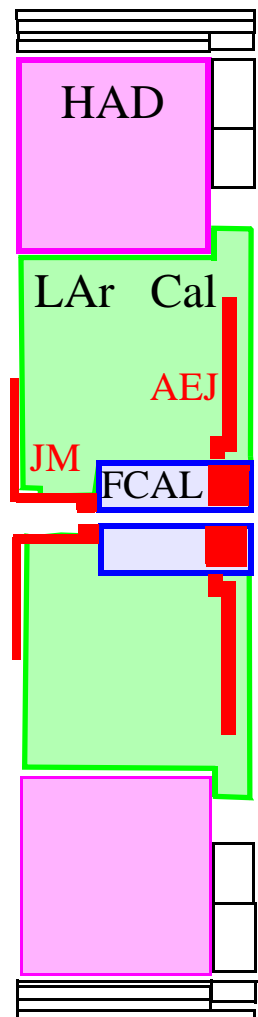
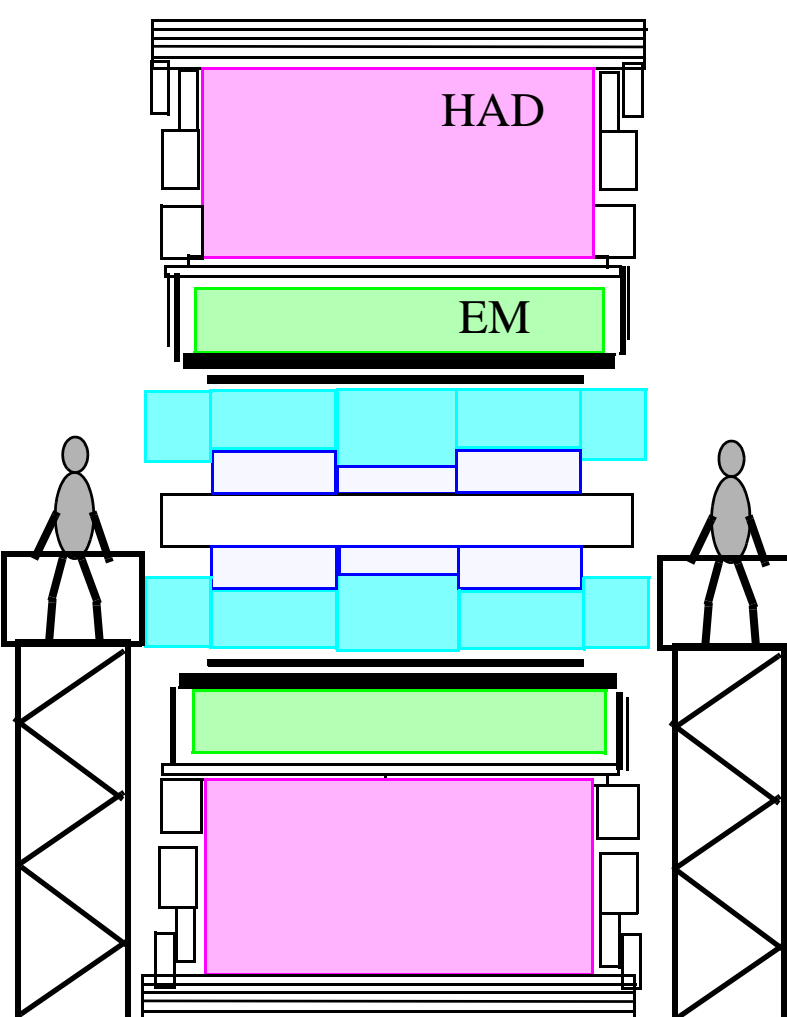

Rails

ACCESS

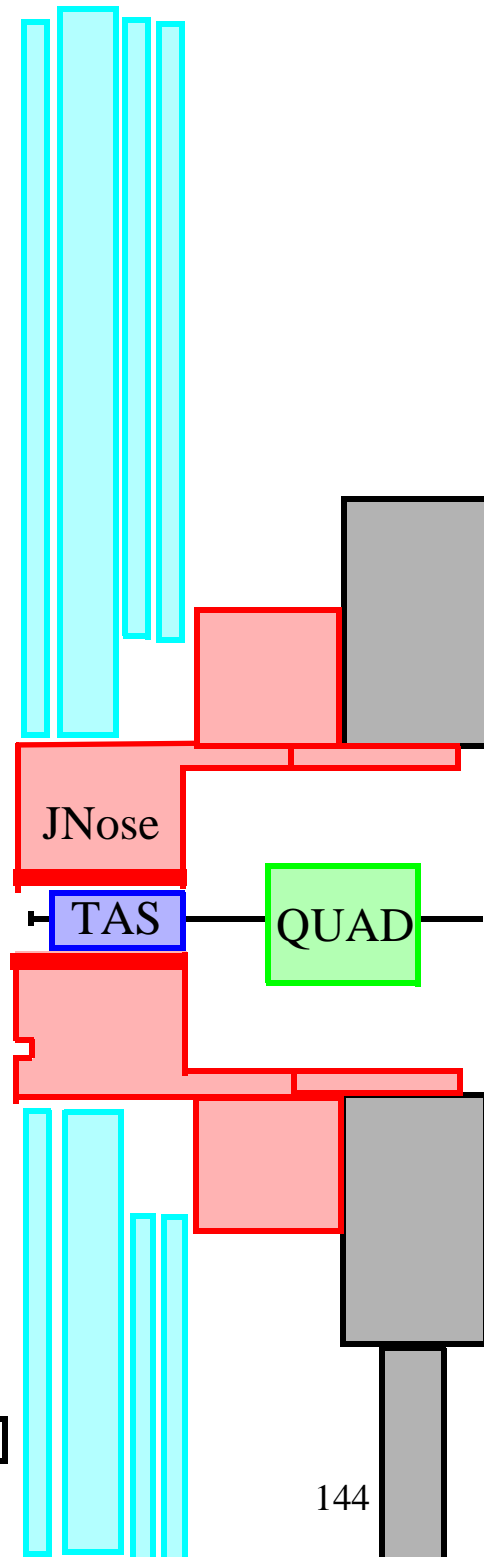
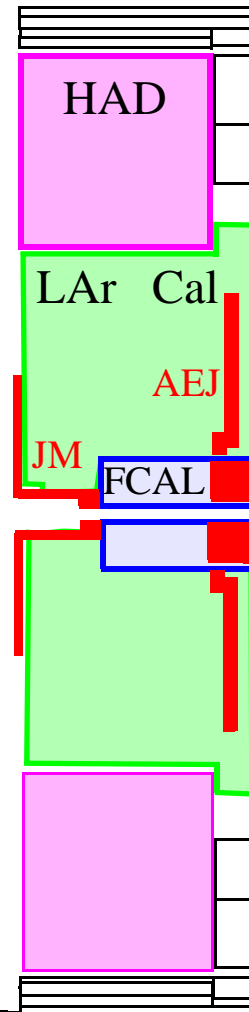
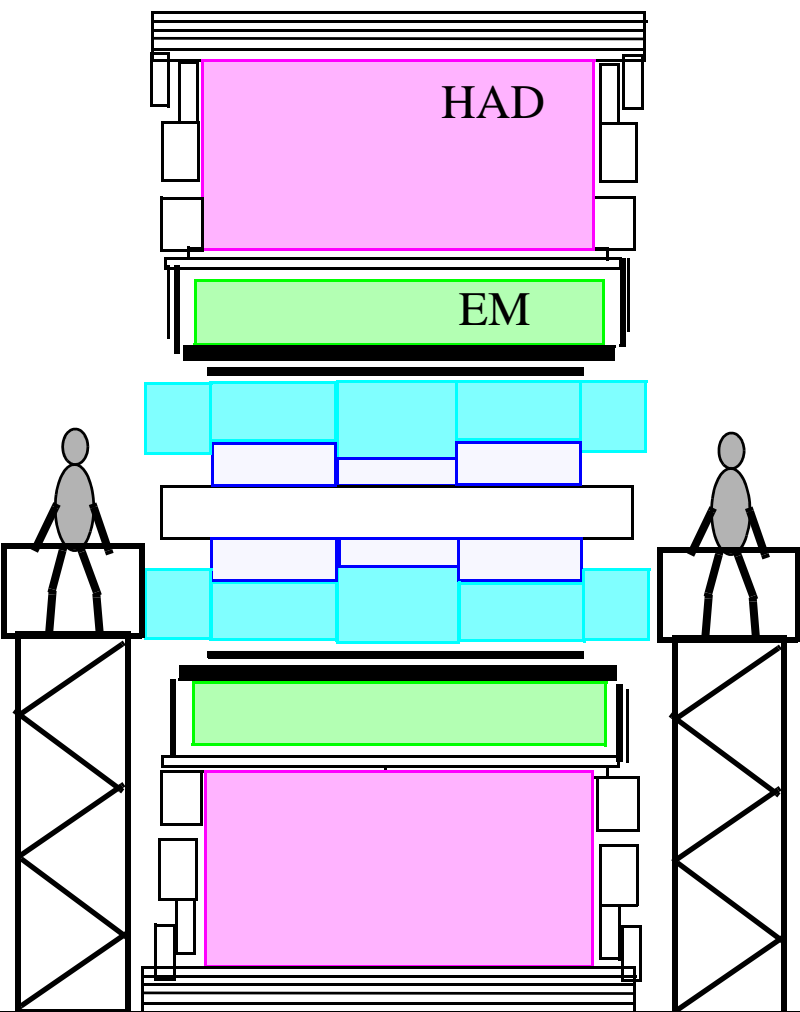

Rails

ACCESS

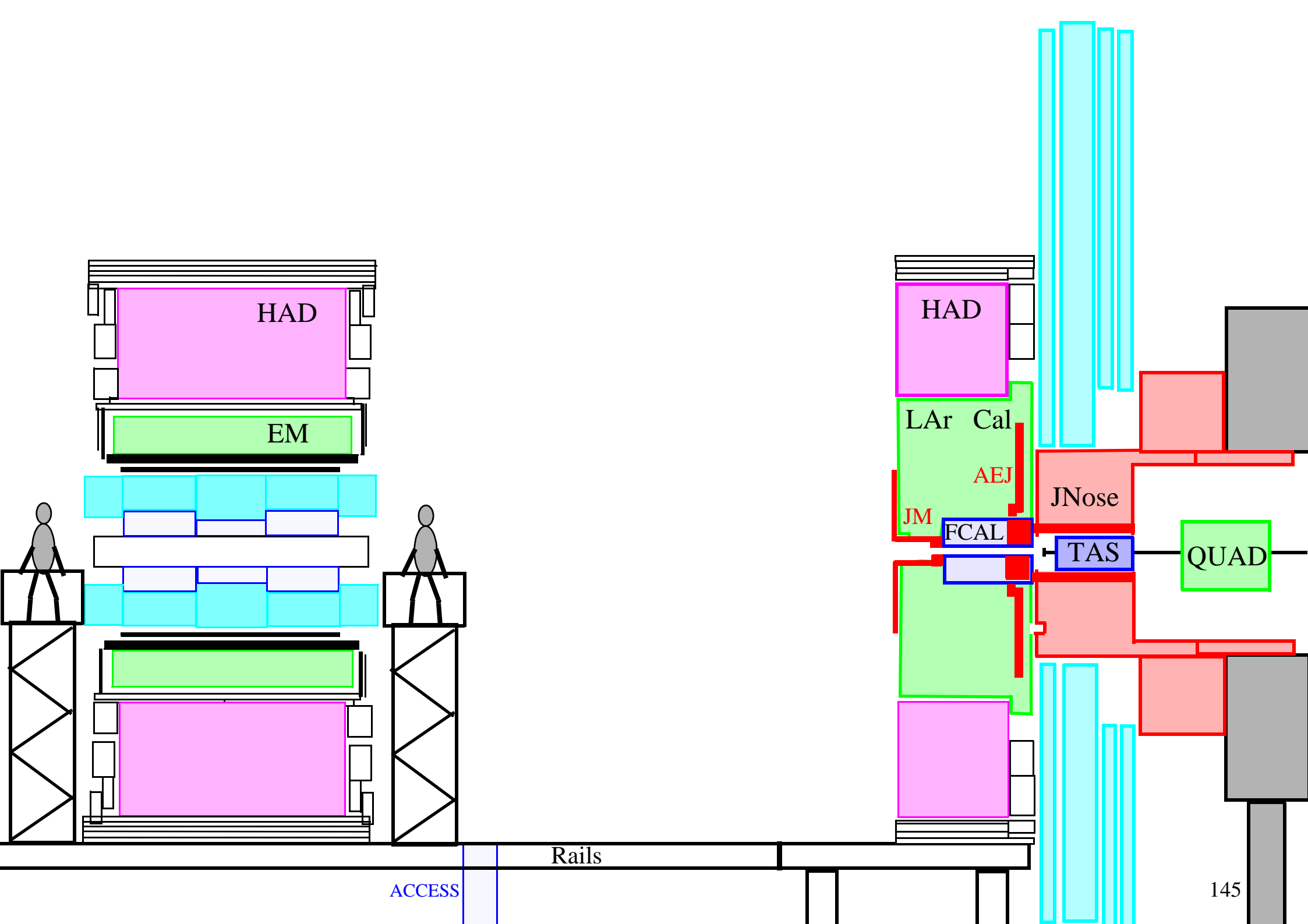

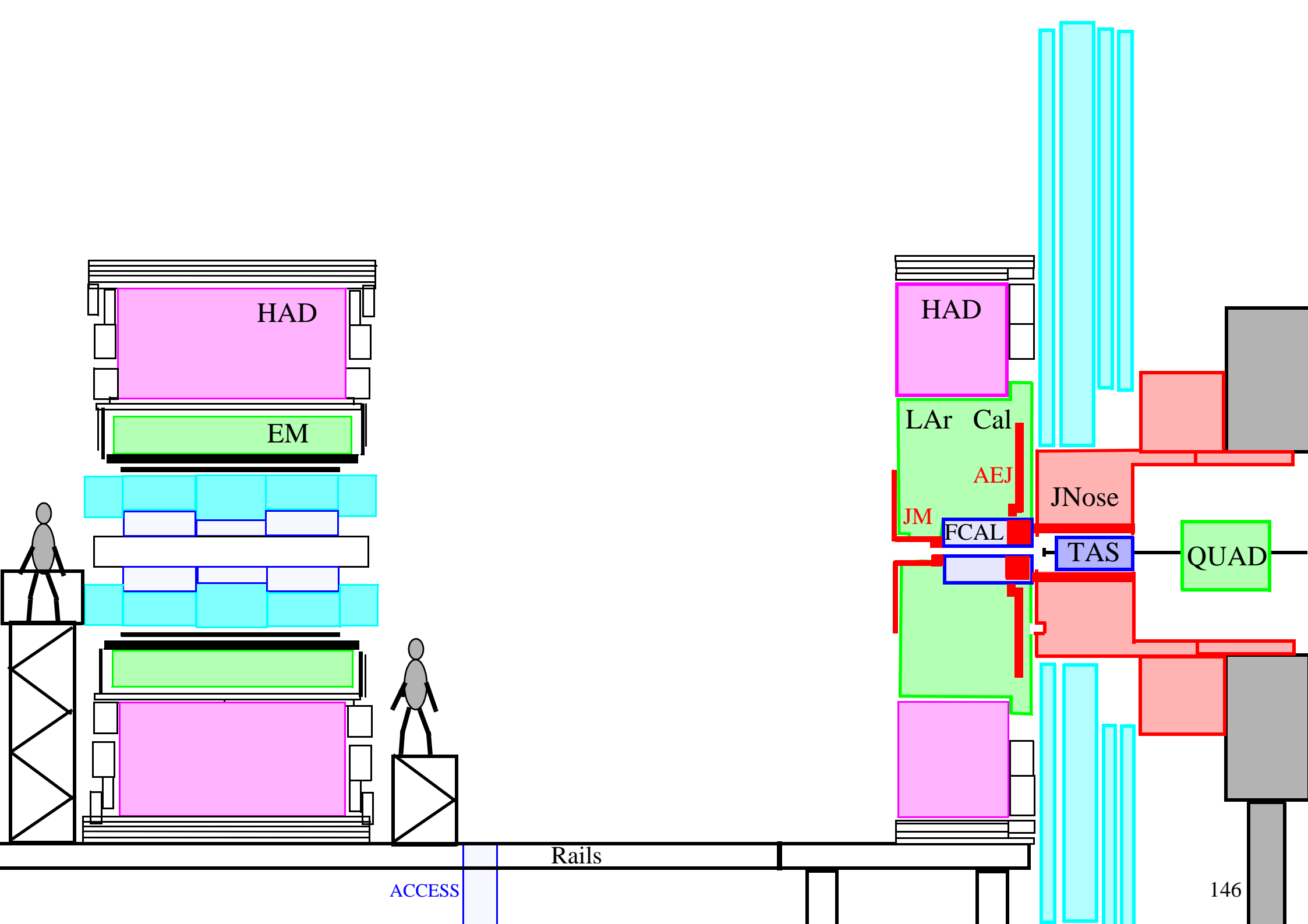

HAD

EM

HAD

LAr Cal

AEJ

JM

FCAL

JNose

TAS

QUAD

Rails

ACCESS

146

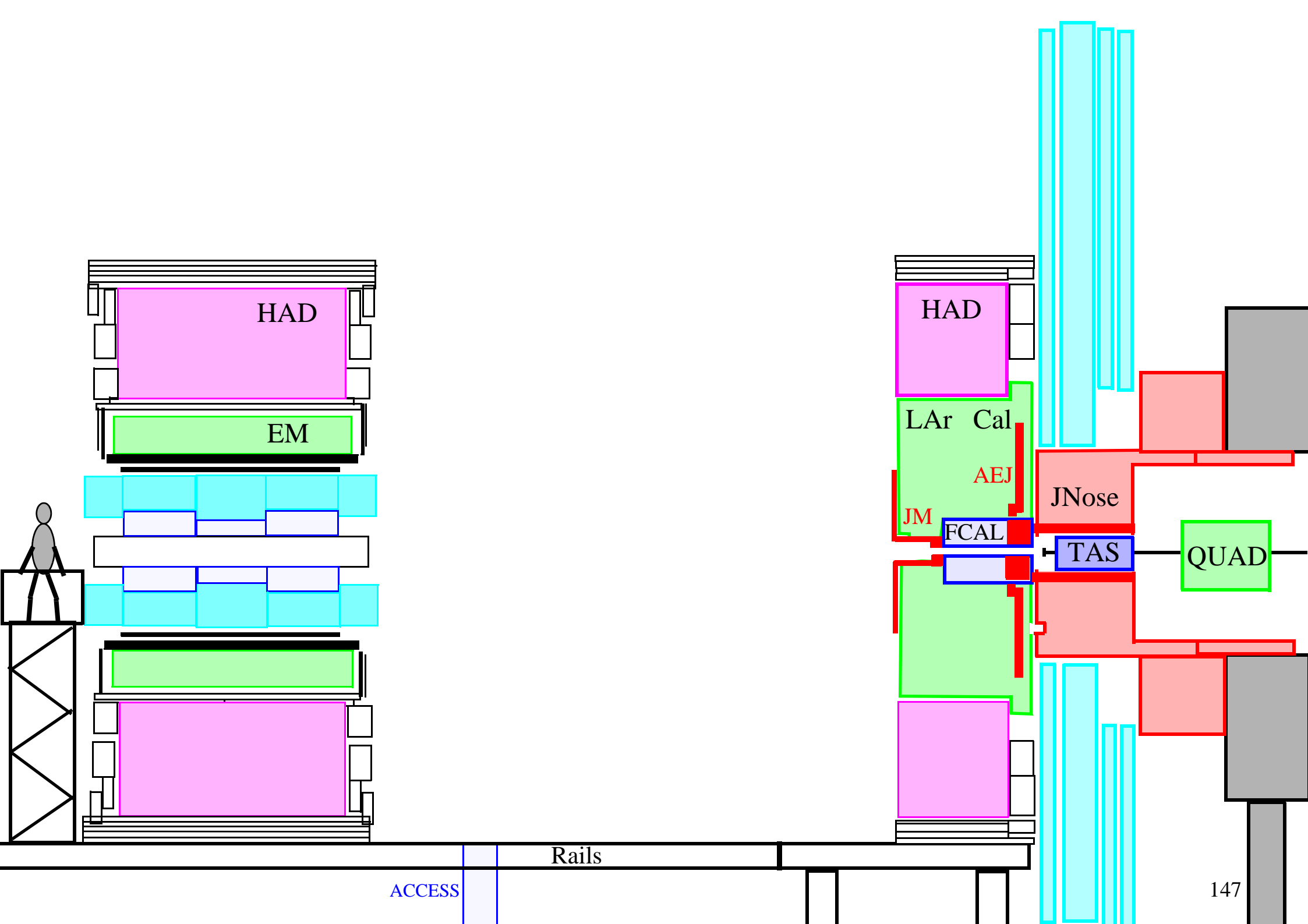

March 2007

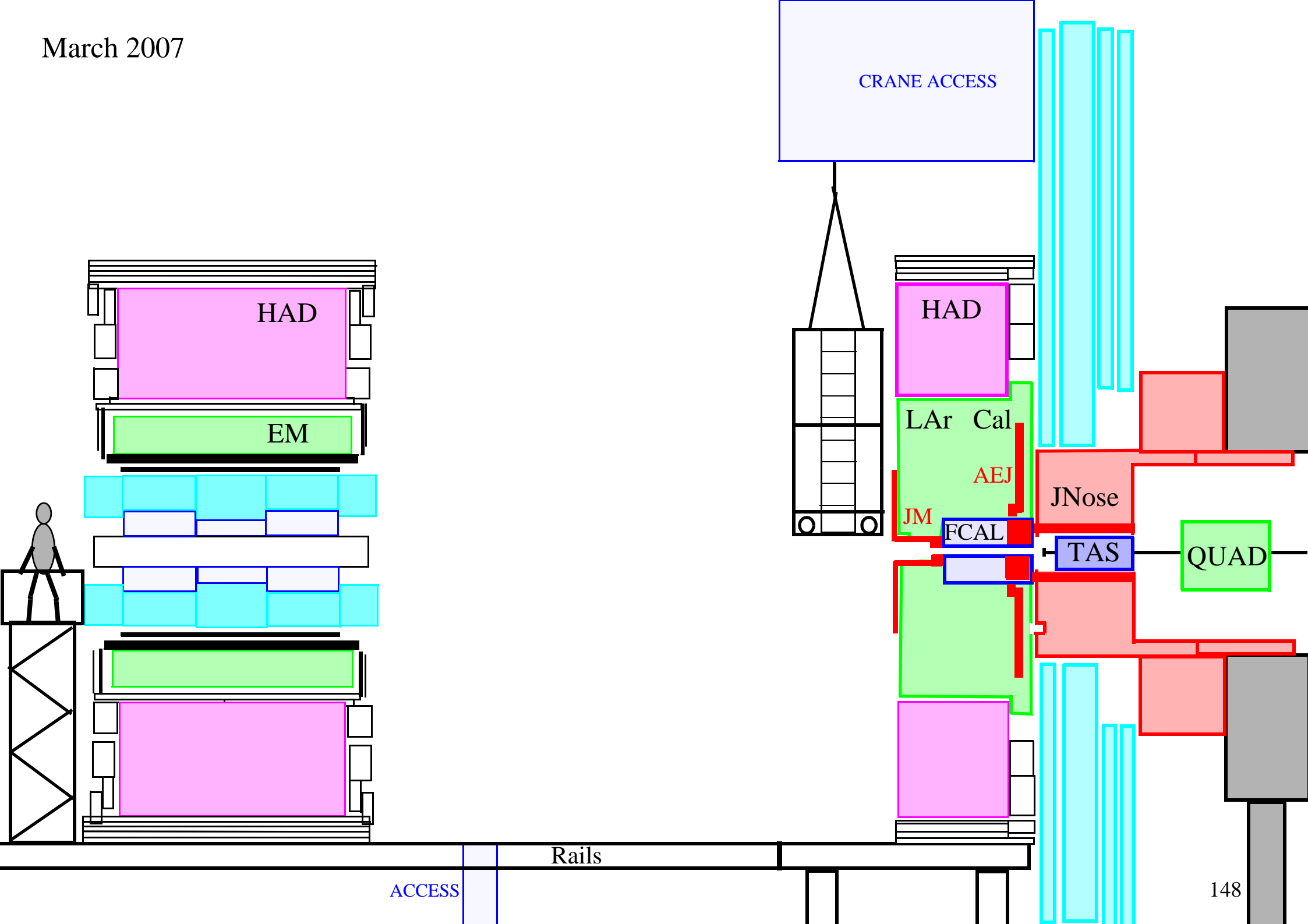

CRANE ACCESS

HAD

EM

HAD

LAr Cal

AEJ

JNose

JM

FCAL

TAS

QUAD

Rails

ACCESS

148

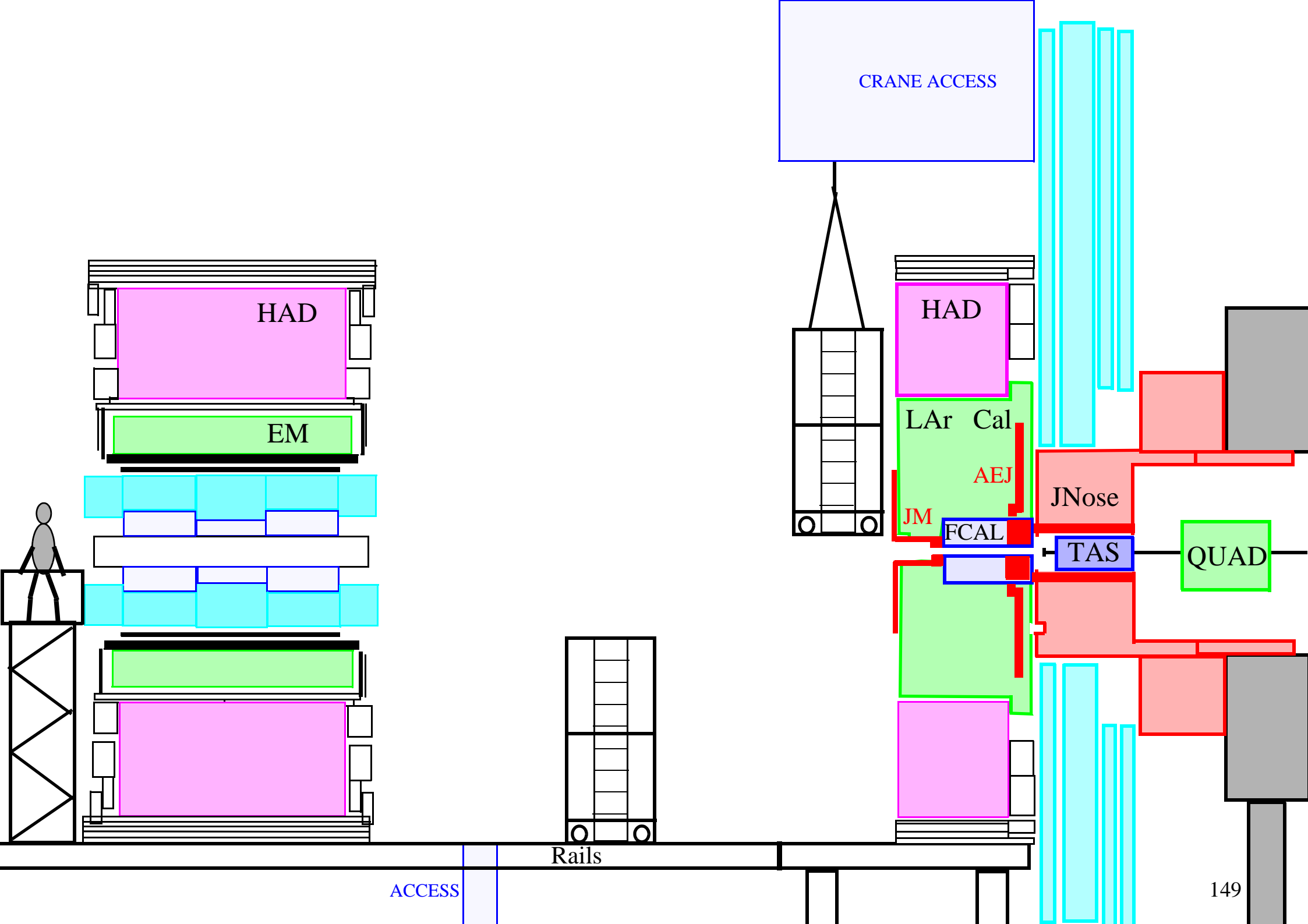

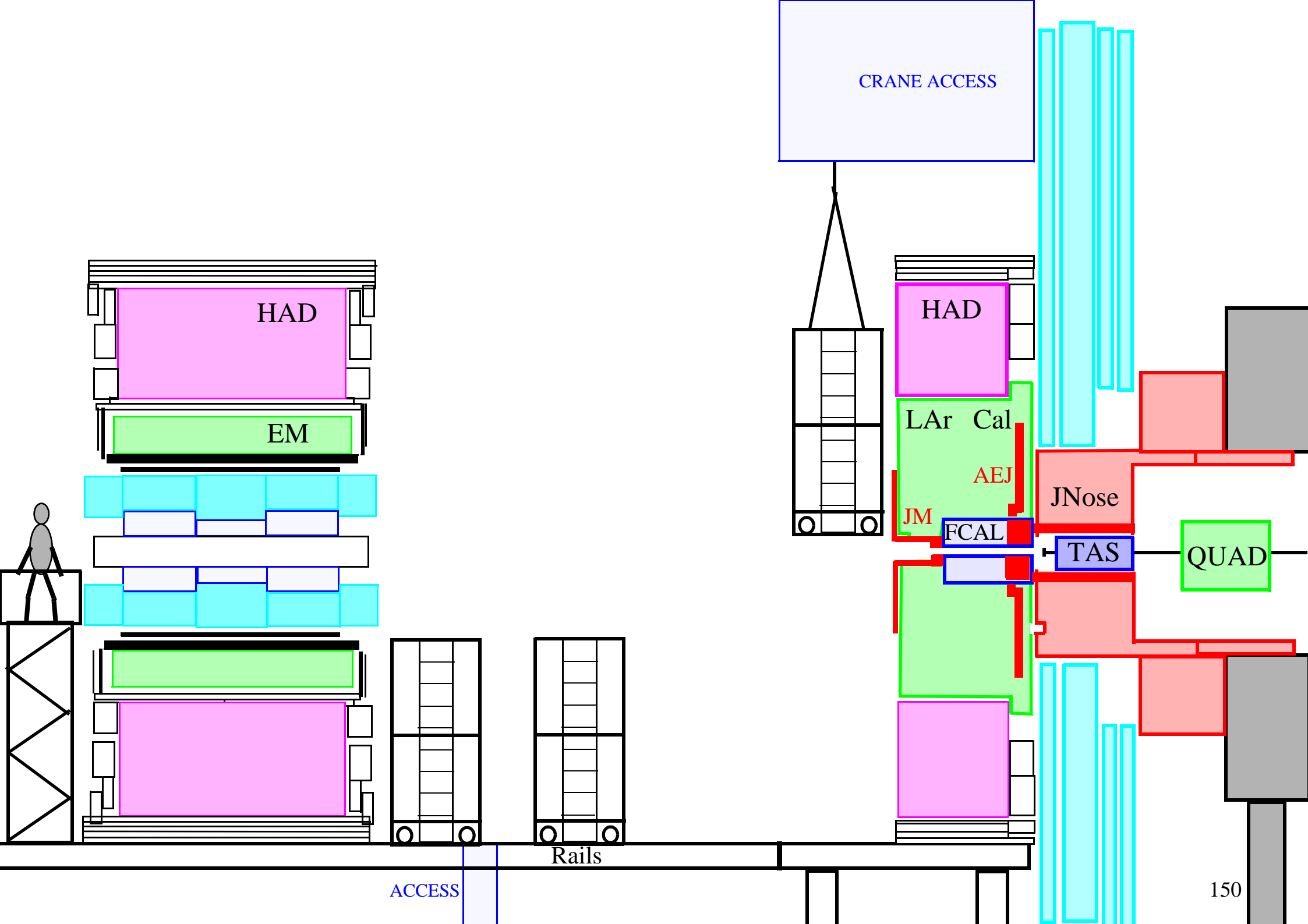

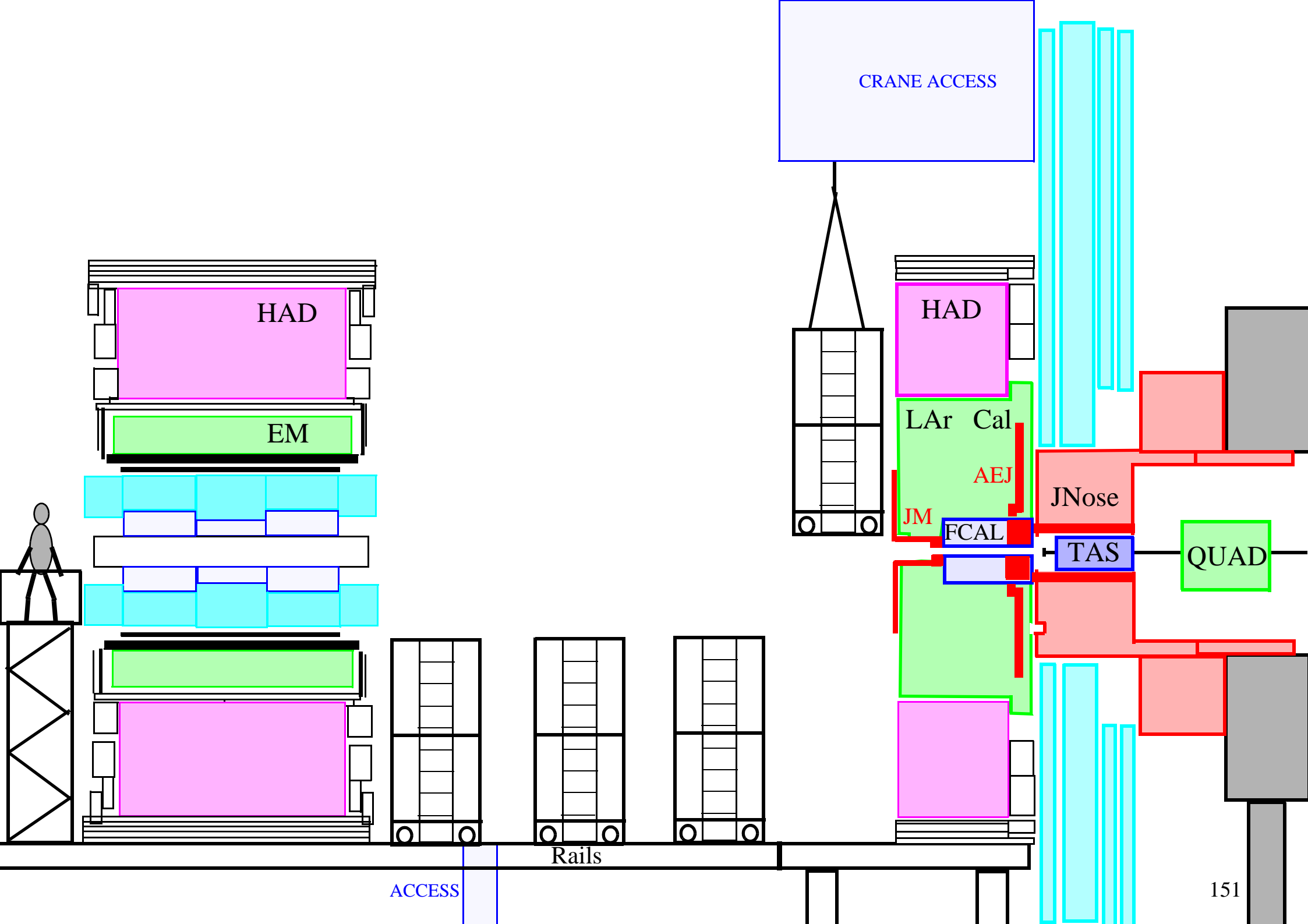

HAD

EM

HAD

HAD

LAr Cal

AEJ

JM

FCAL

JNose

TAS

QUAD

CRANE ACCESS

ACCESS

Rails

151

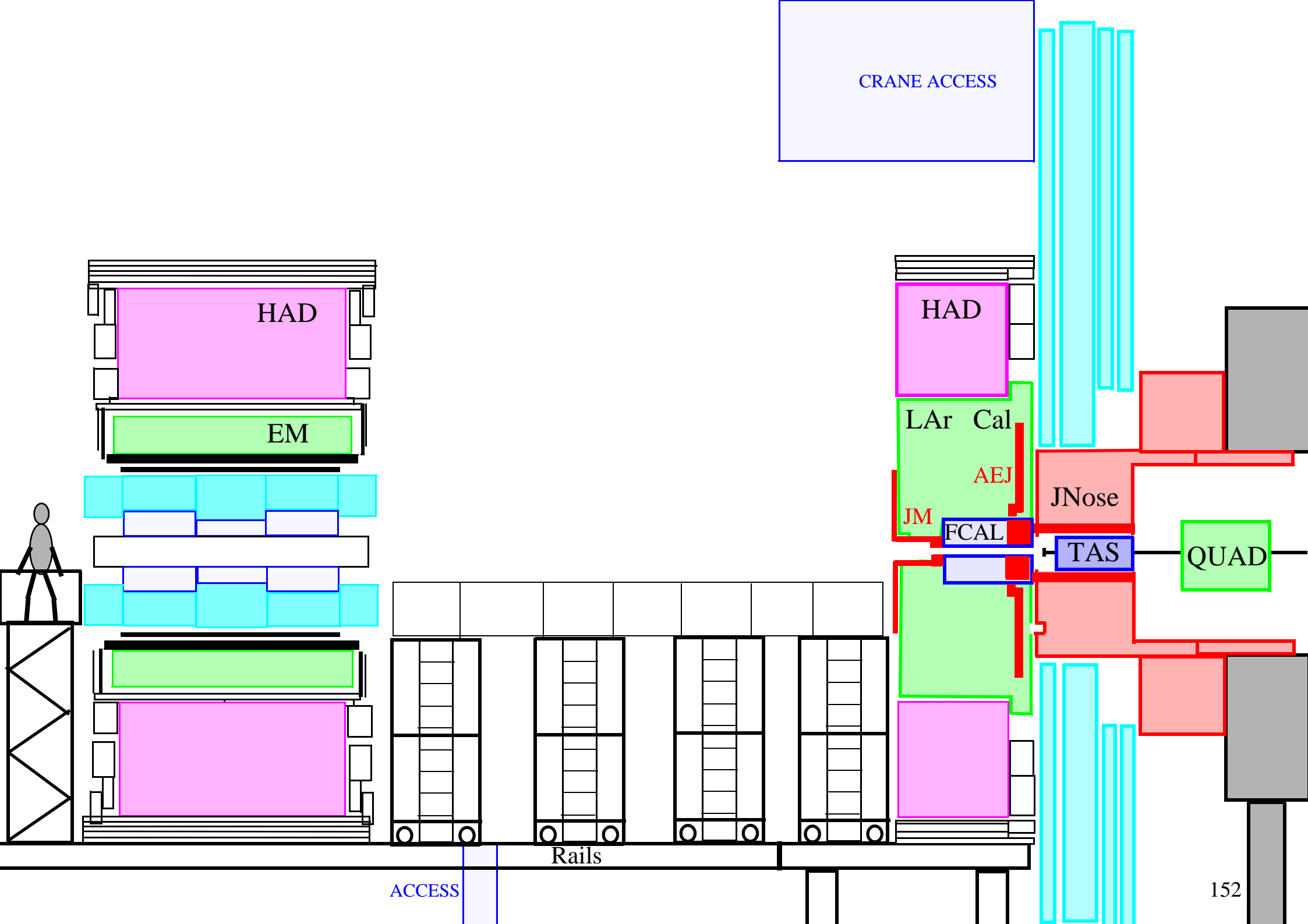

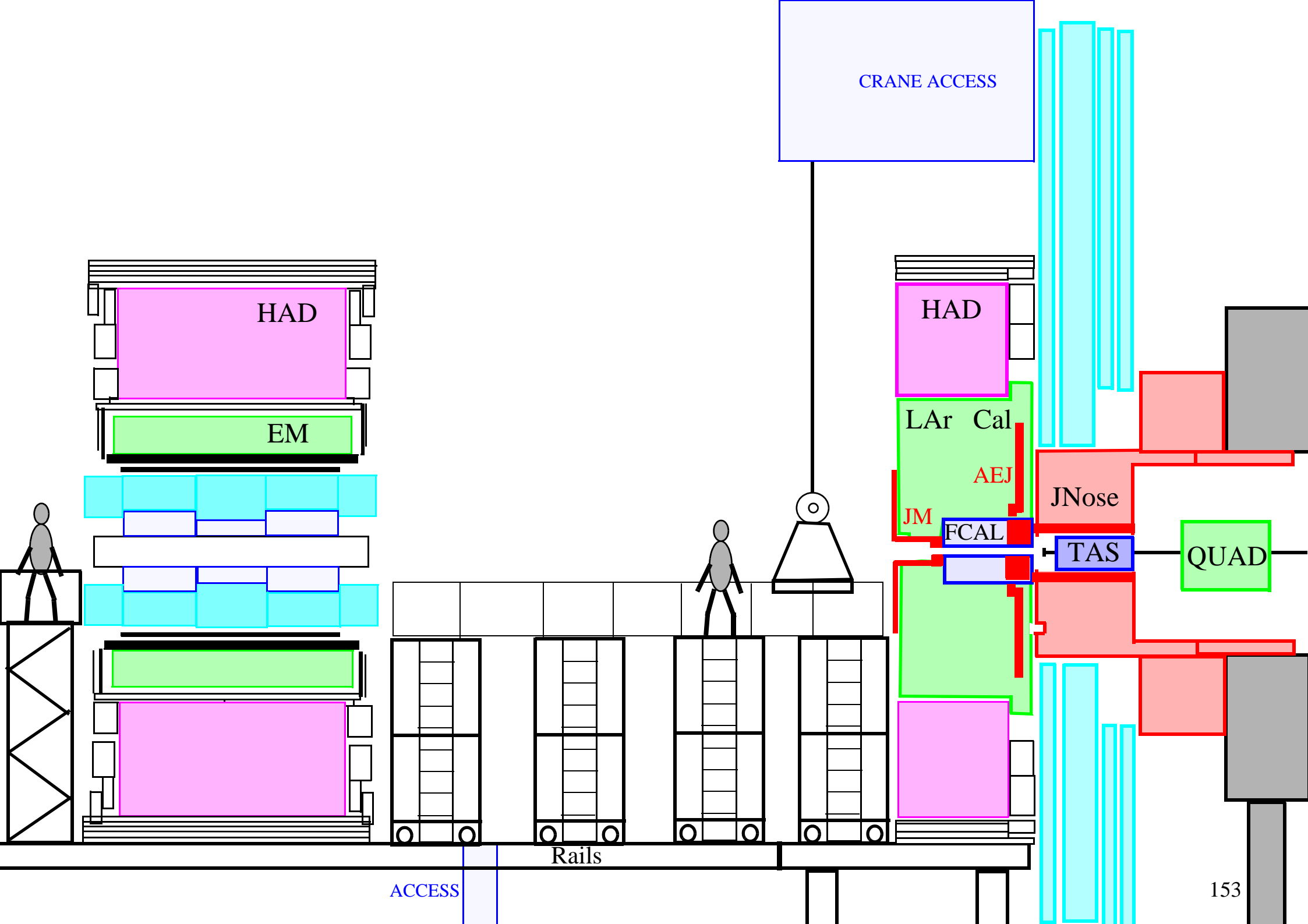

Is scaffolding on this side sufficient ?

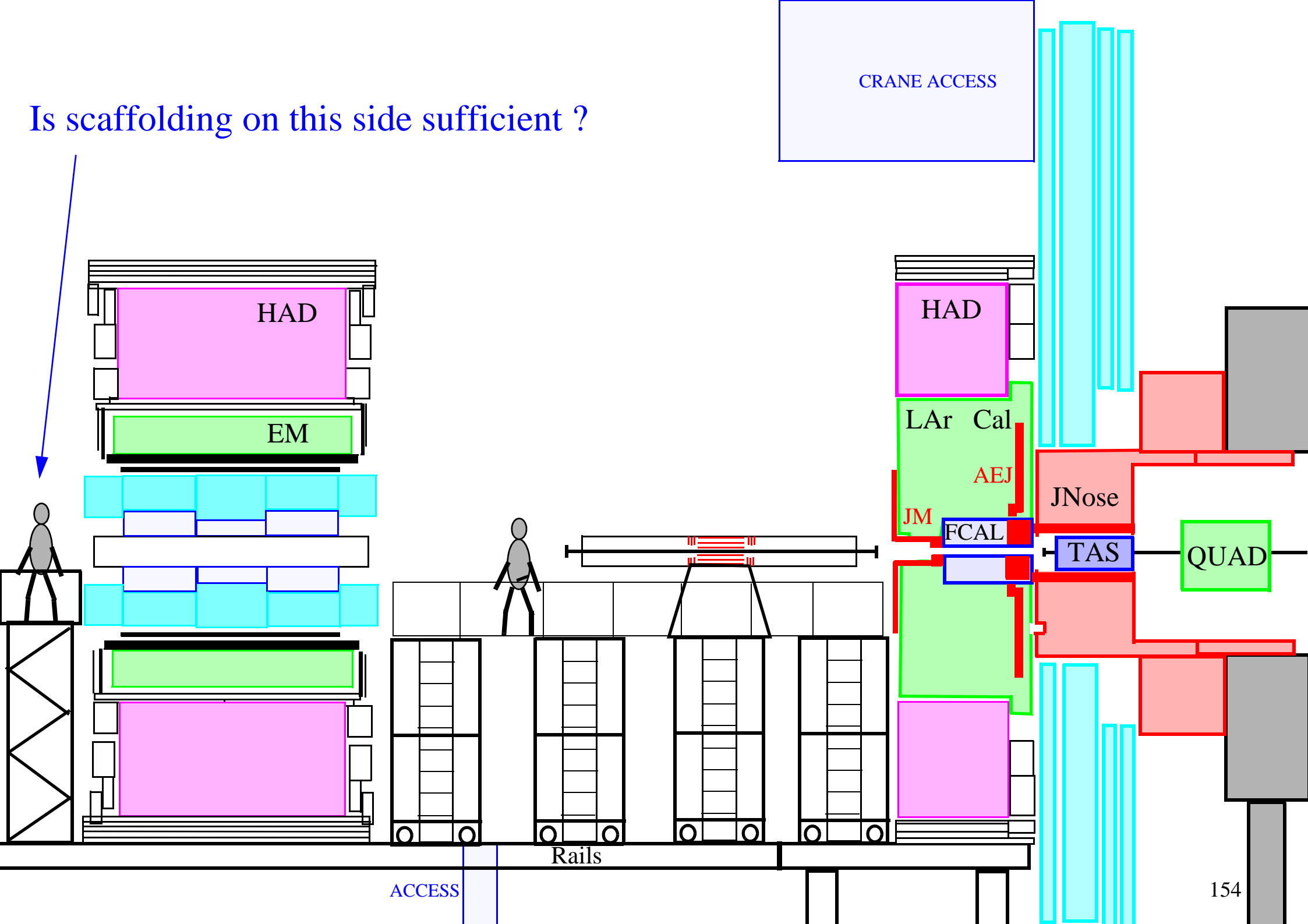

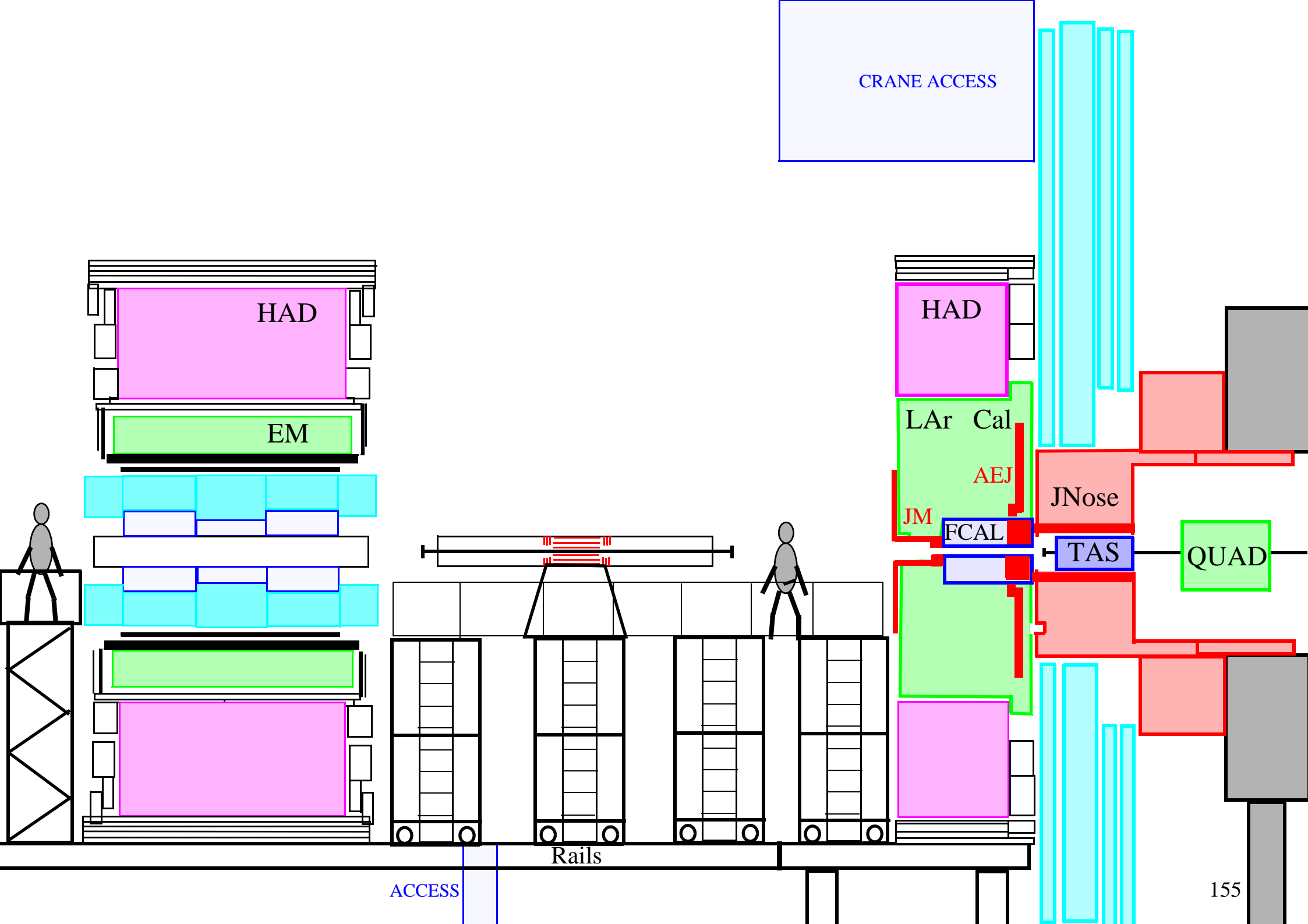

CRANE ACCESS

HAD

EM

HAD

LAr Cal

AEJ

JM

FCAL

JNose

TAS

QUAD

Rails

ACCESS

155

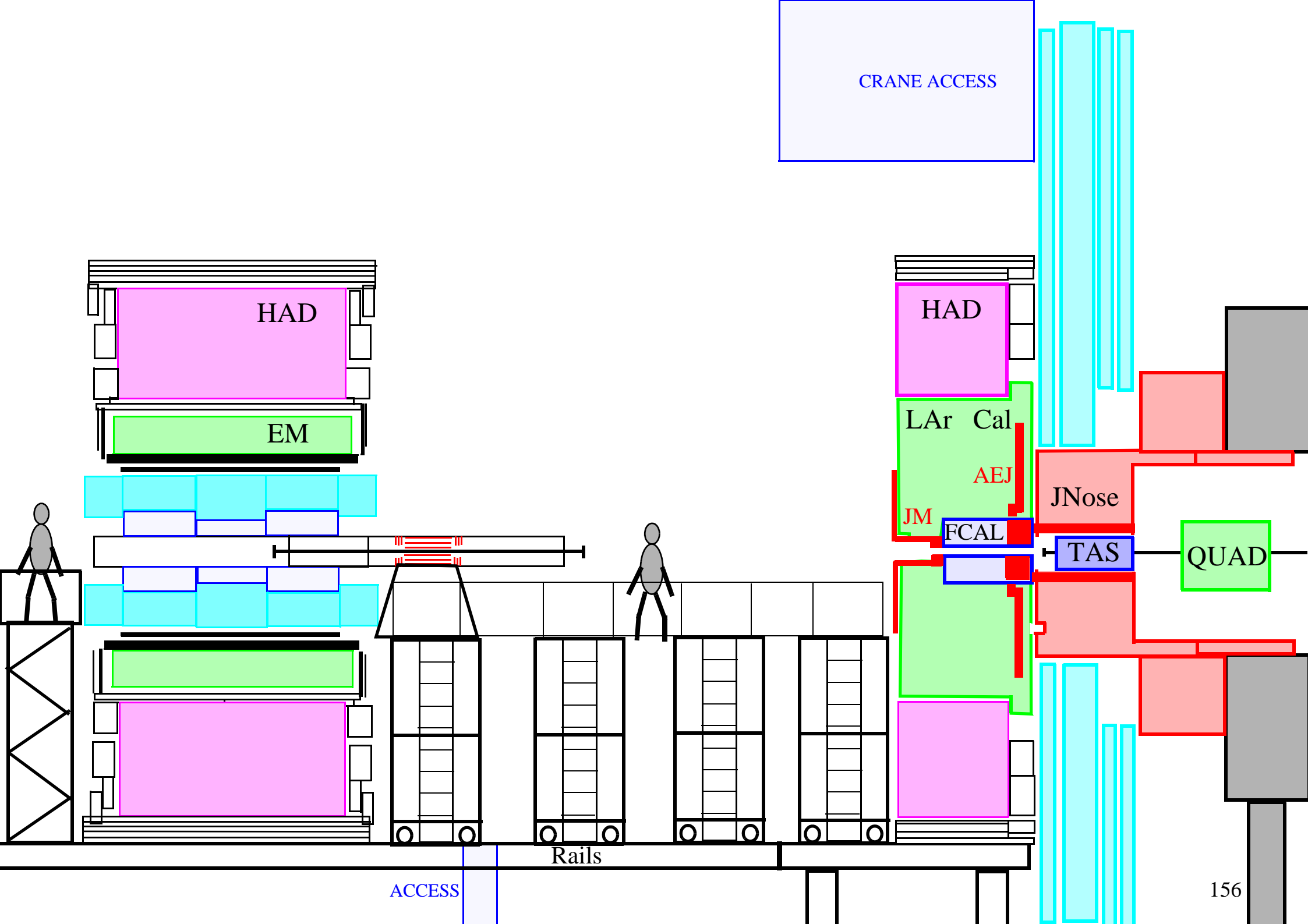

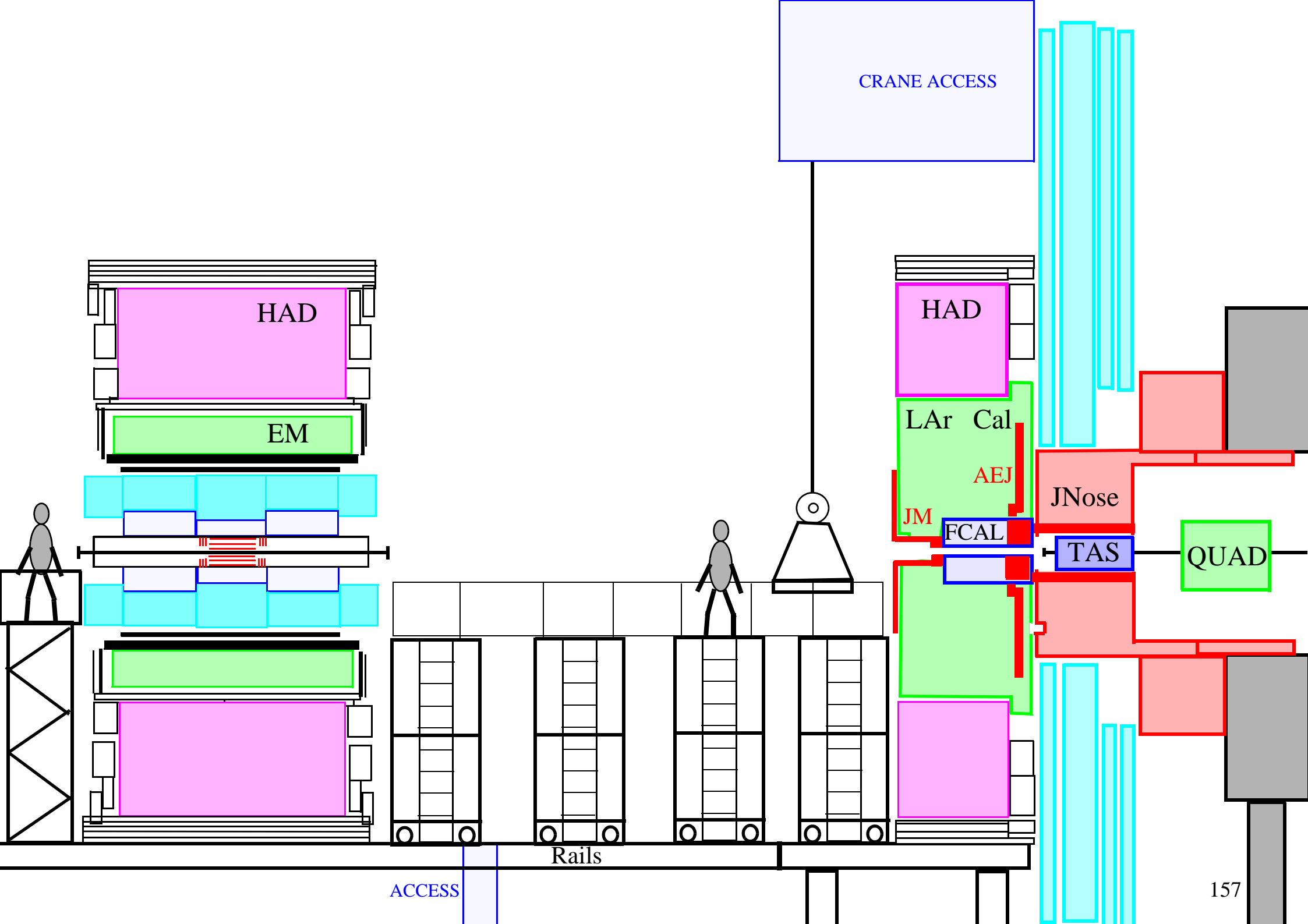

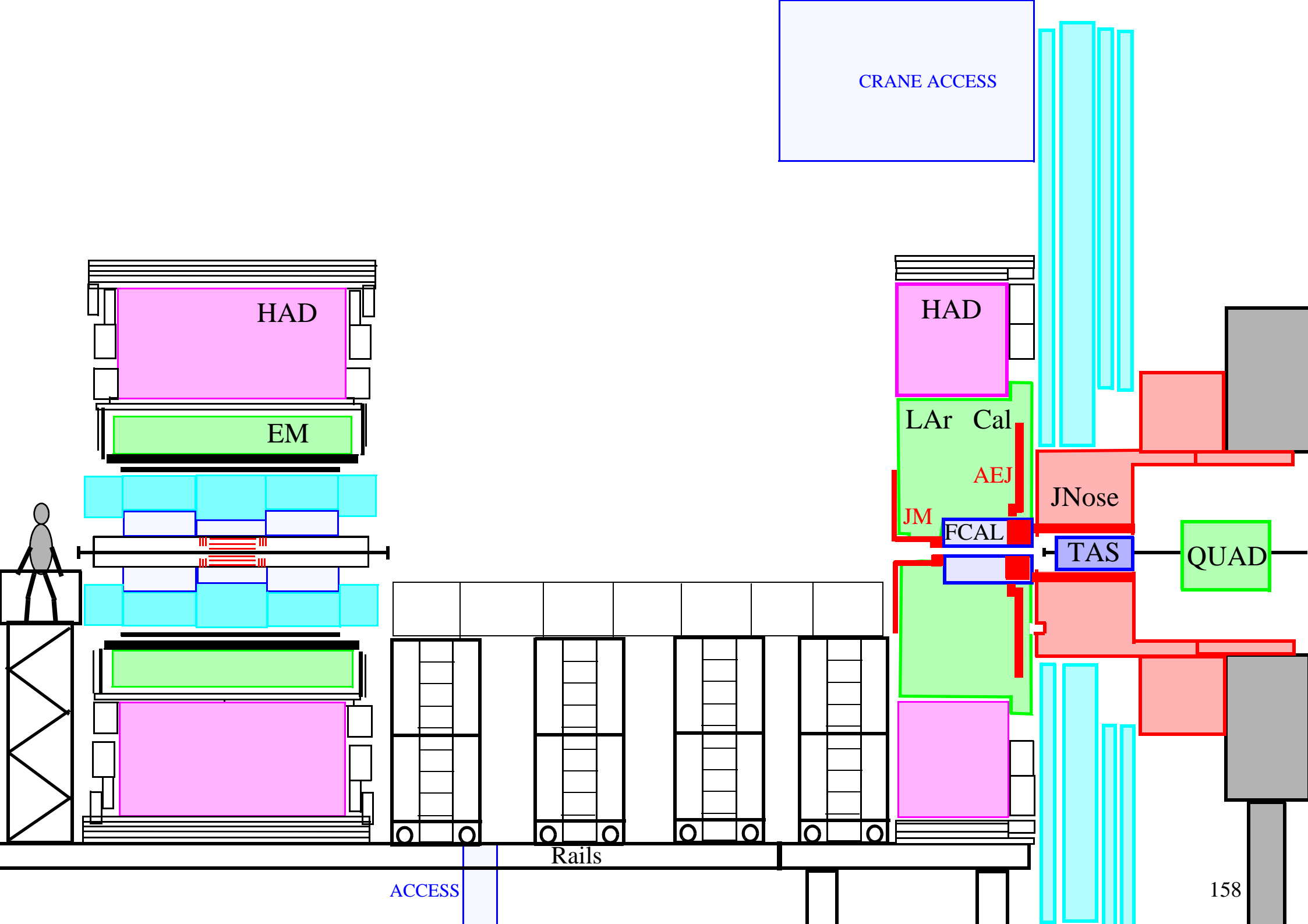

CRANE ACCESS

HAD

EM

HAD

LAr Cal

AEJ

JNose

JM

FCAL

TAS

QUAD

Rails

ACCESS

158

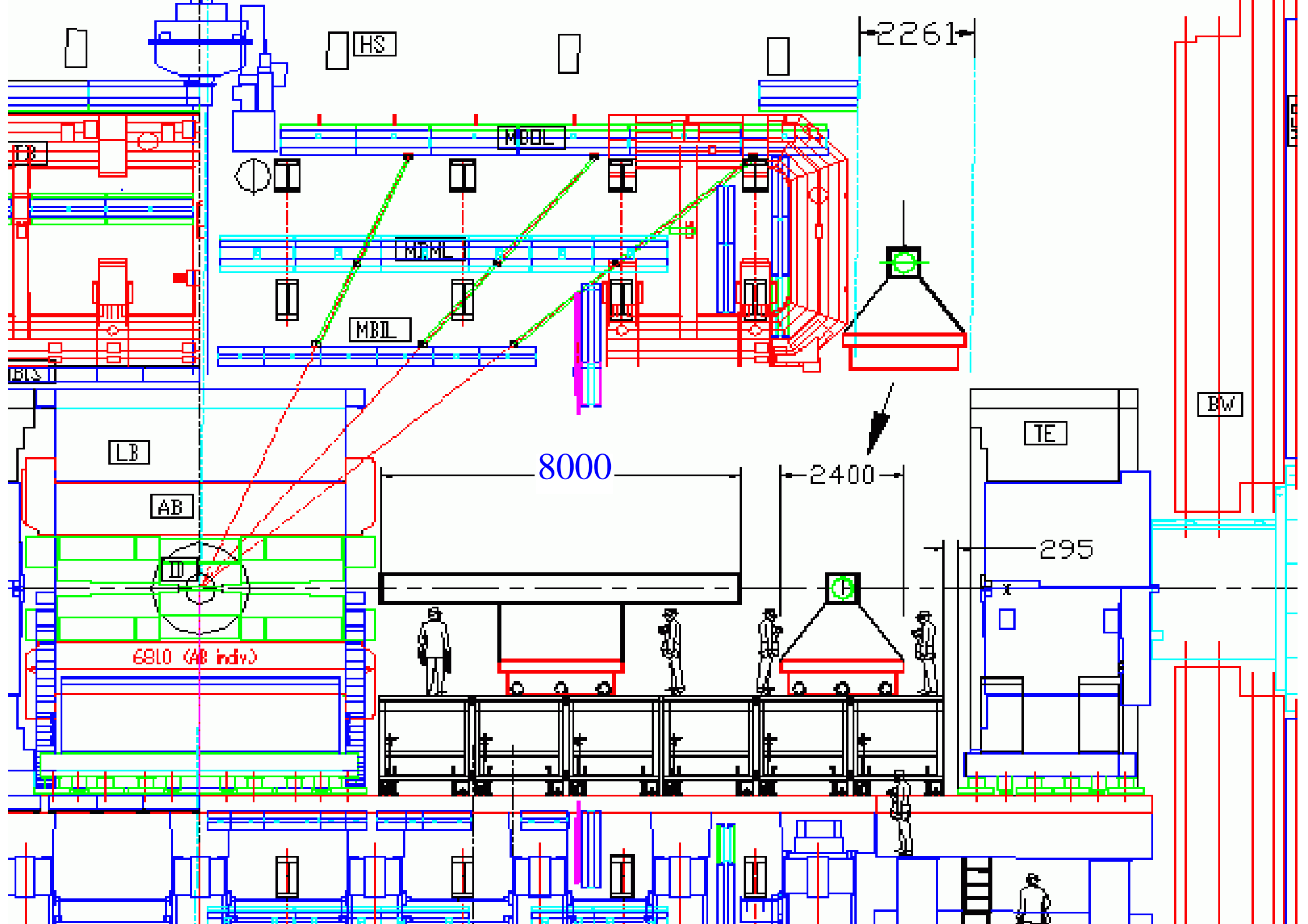

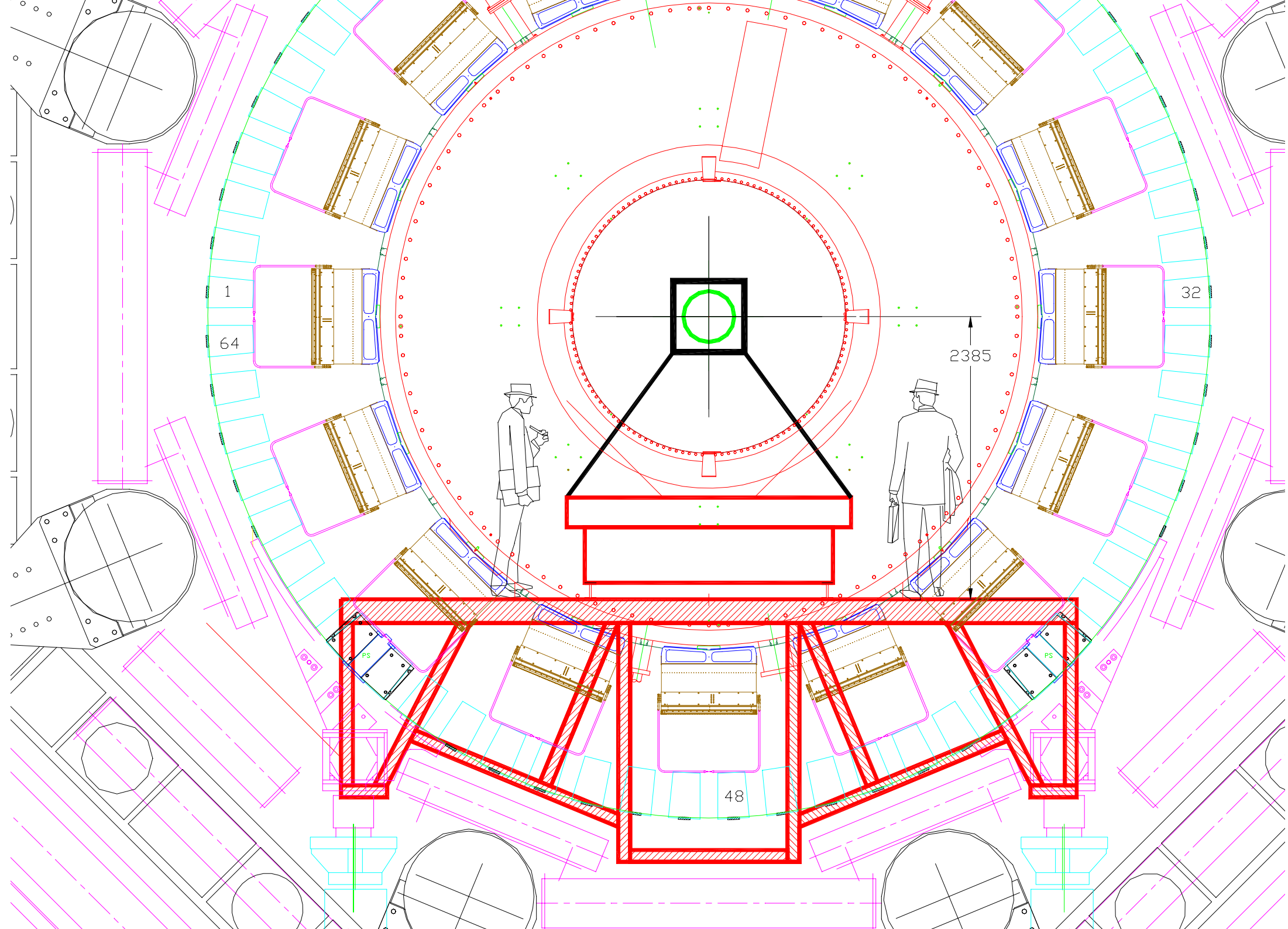

1

64

32

2385

48

PS

PS

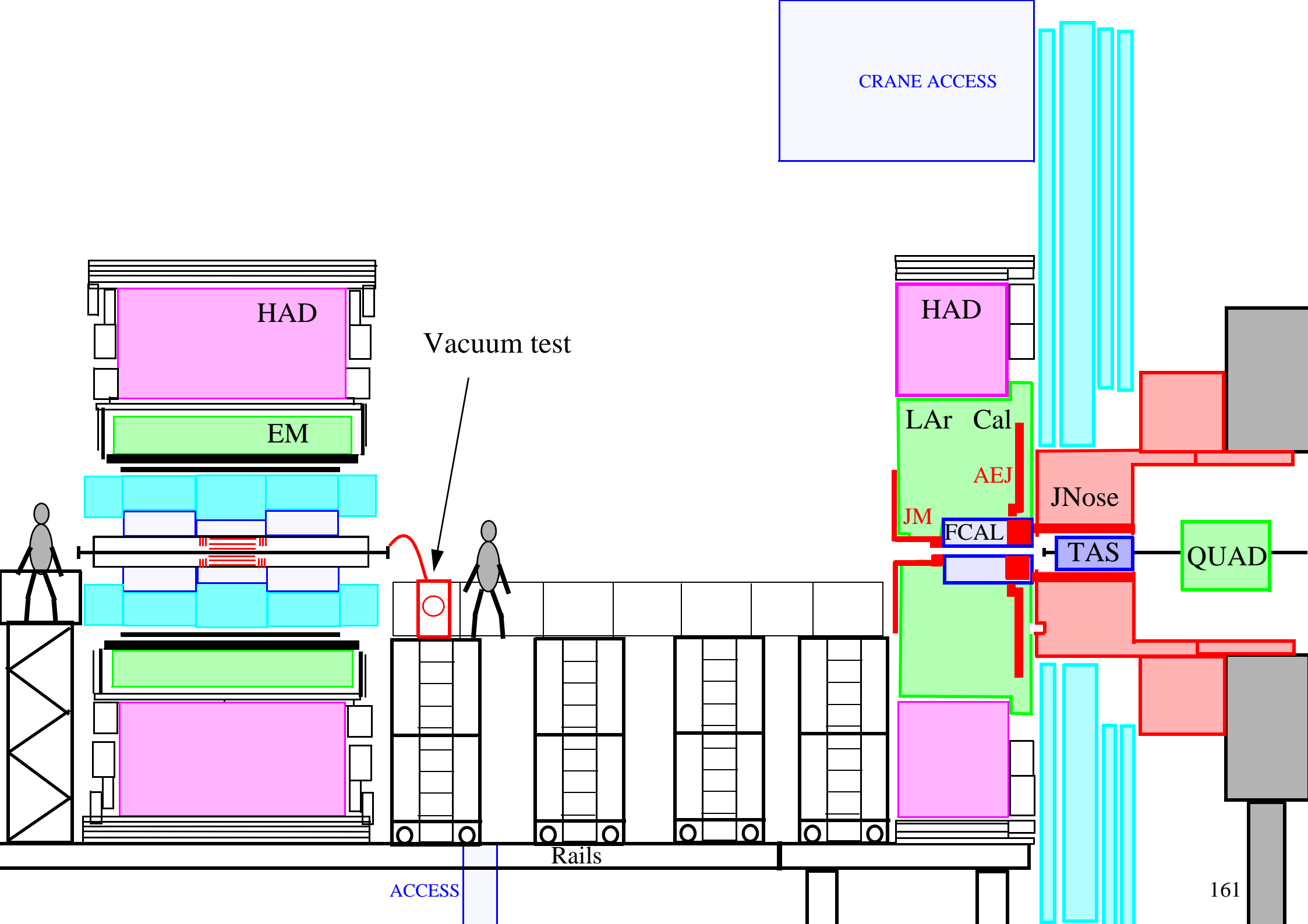

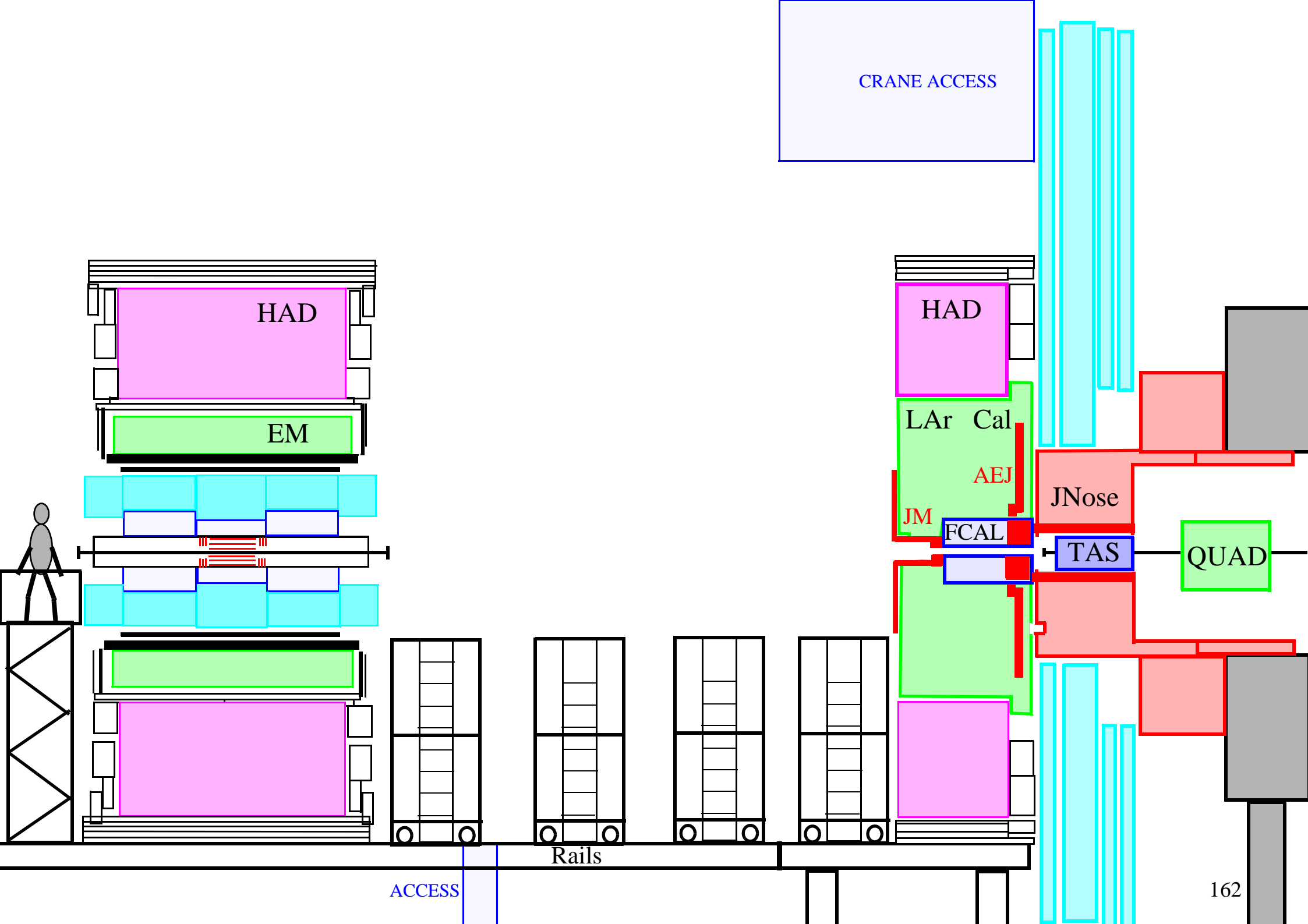

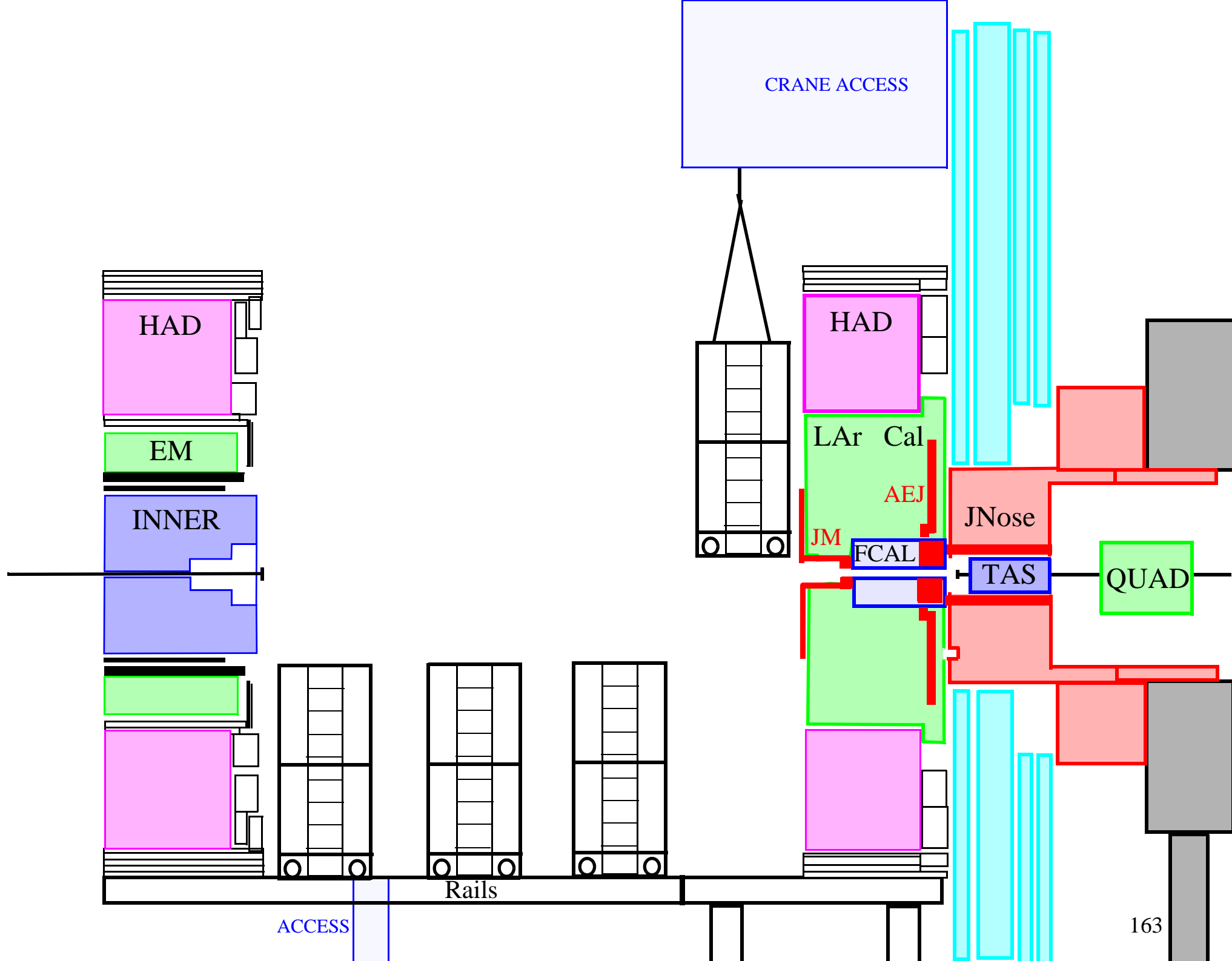

CRANE ACCESS

HAD

EM

INNER

HAD

LAr Cal

AEJ

JM

FCAL

JNose

TAS

QUAD

Rails

ACCESS

163

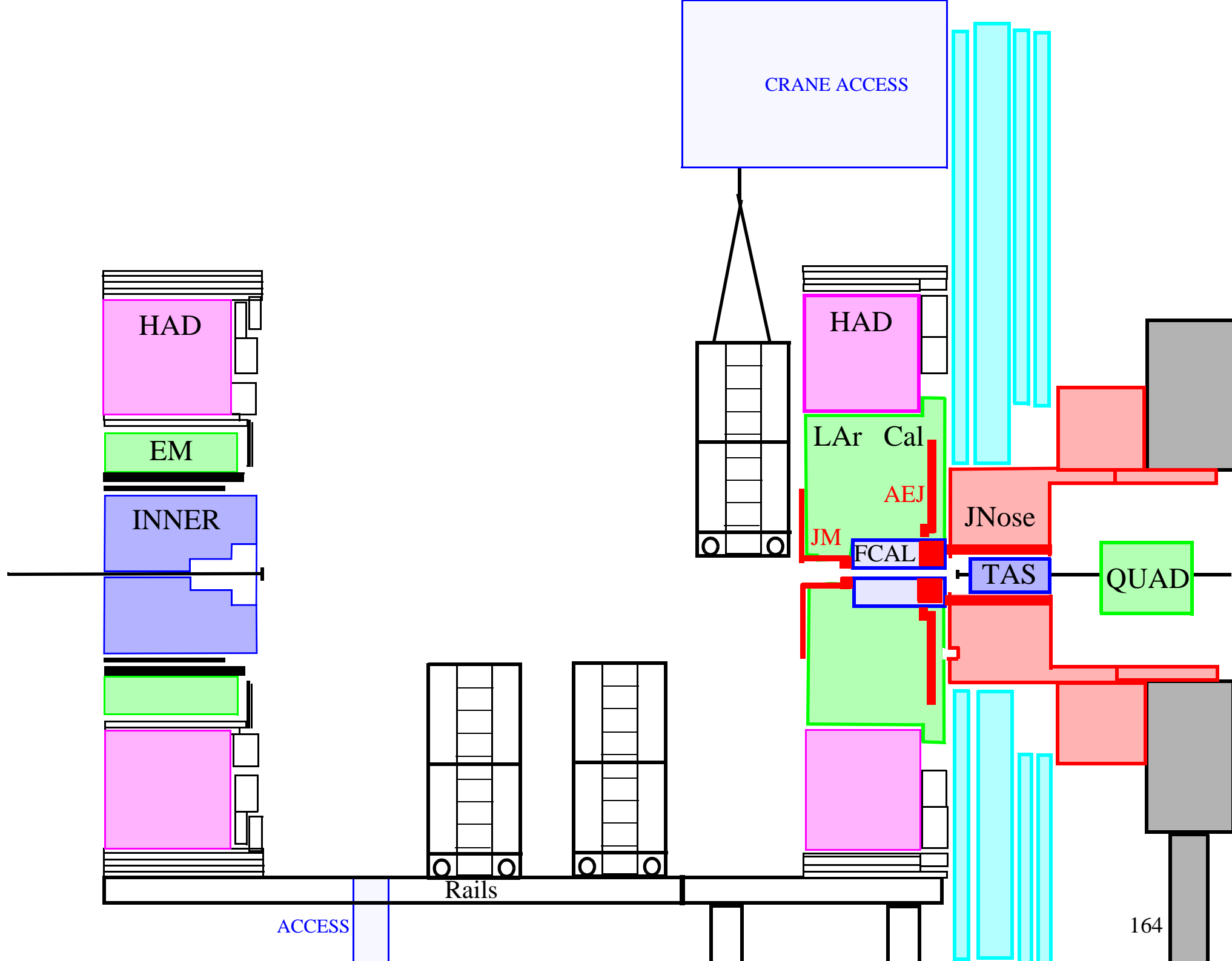

CRANE ACCESS

HAD

EM

INNER

HAD

LAr Cal

AEJ

JNose

JM

FCAL

TAS

QUAD

Rails

ACCESS

164

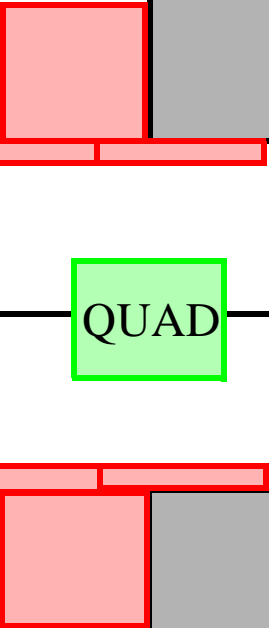
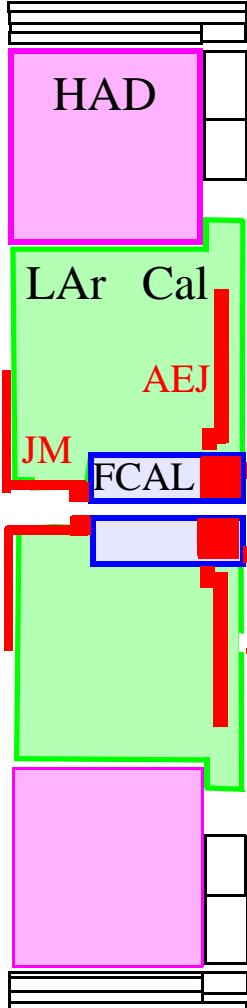
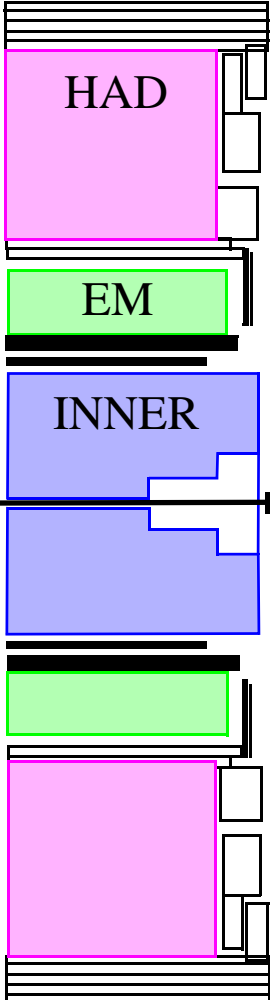
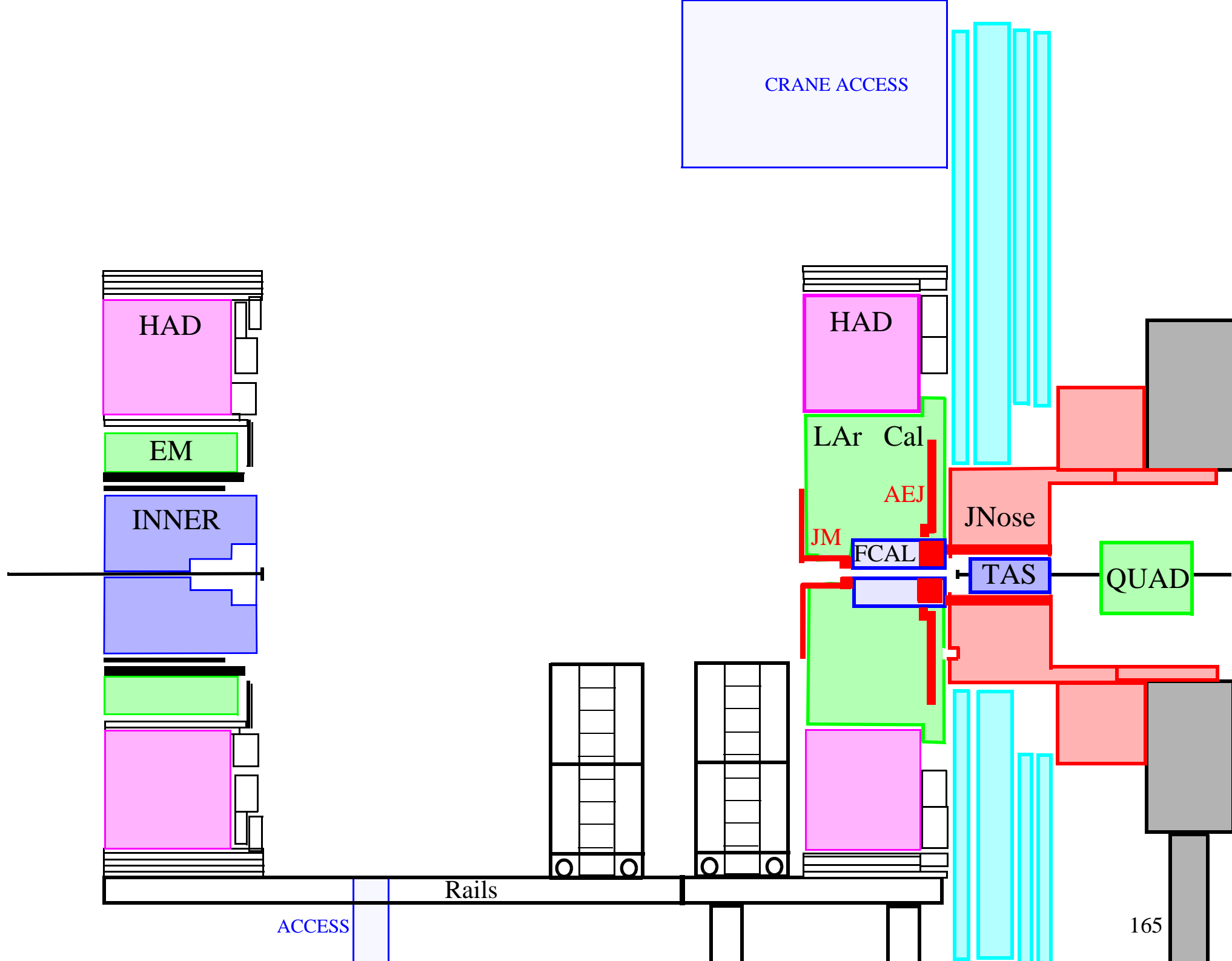

ACCESS (blue text)

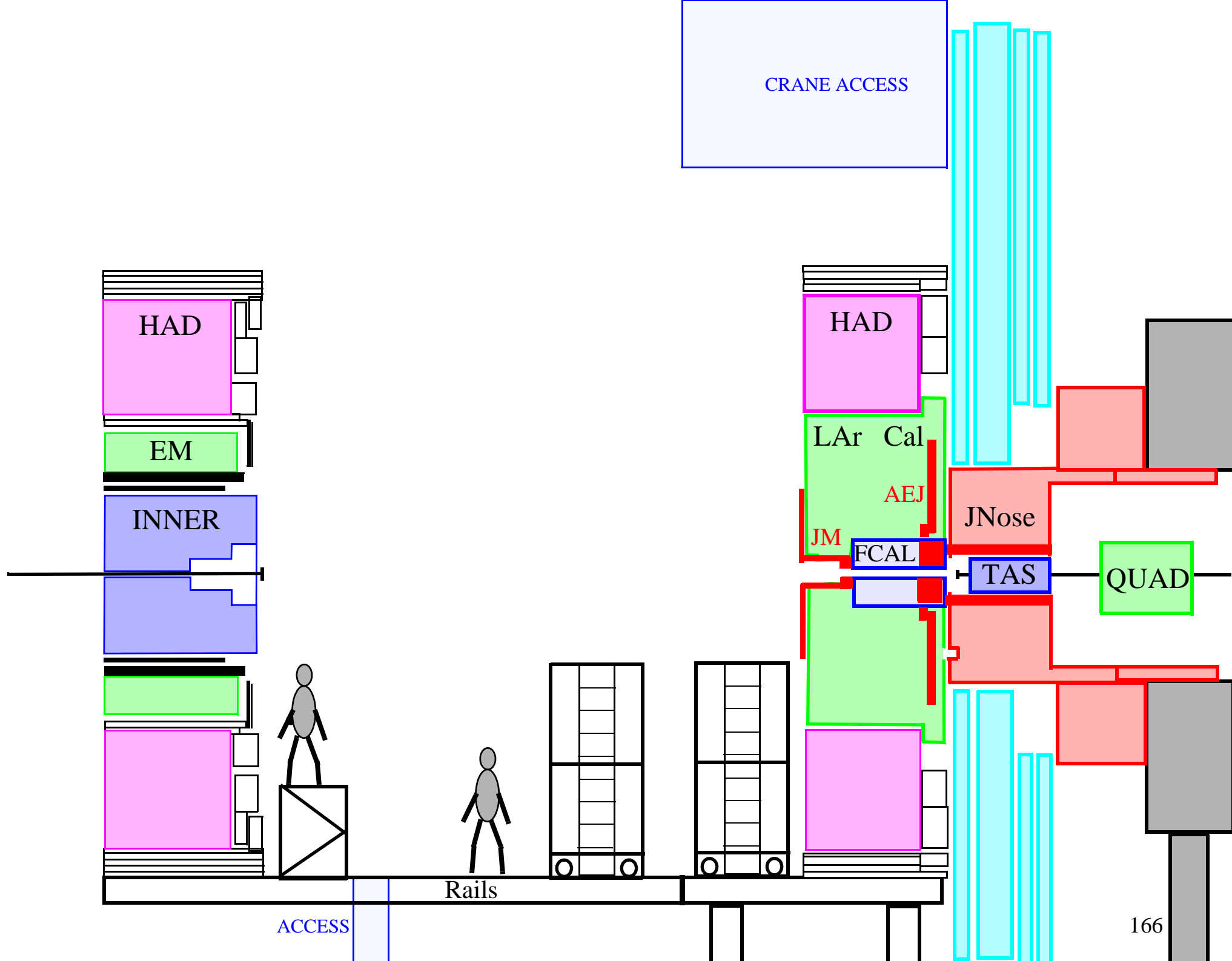

CRANE ACCESS

HAD

EM

INNER

HAD

LAr Cal

AEJ

JM

FCAL

JNose

TAS

QUAD

Rails

ACCESS

166

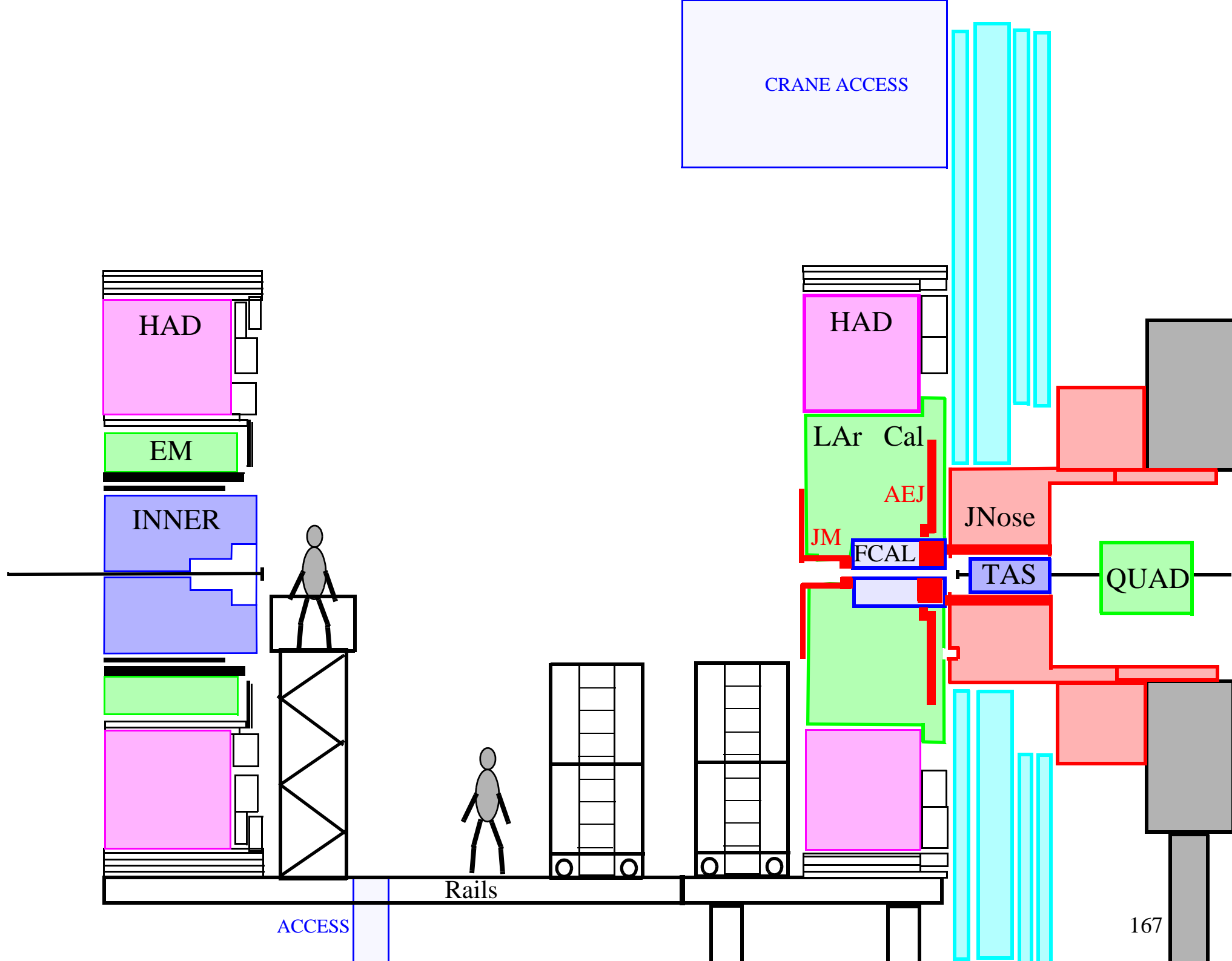

CRANE ACCESS

HAD

EM

INNER

HAD

LAr Cal

AEJ

JM

FCAL

JNose

TAS

QUAD

Rails

ACCESS

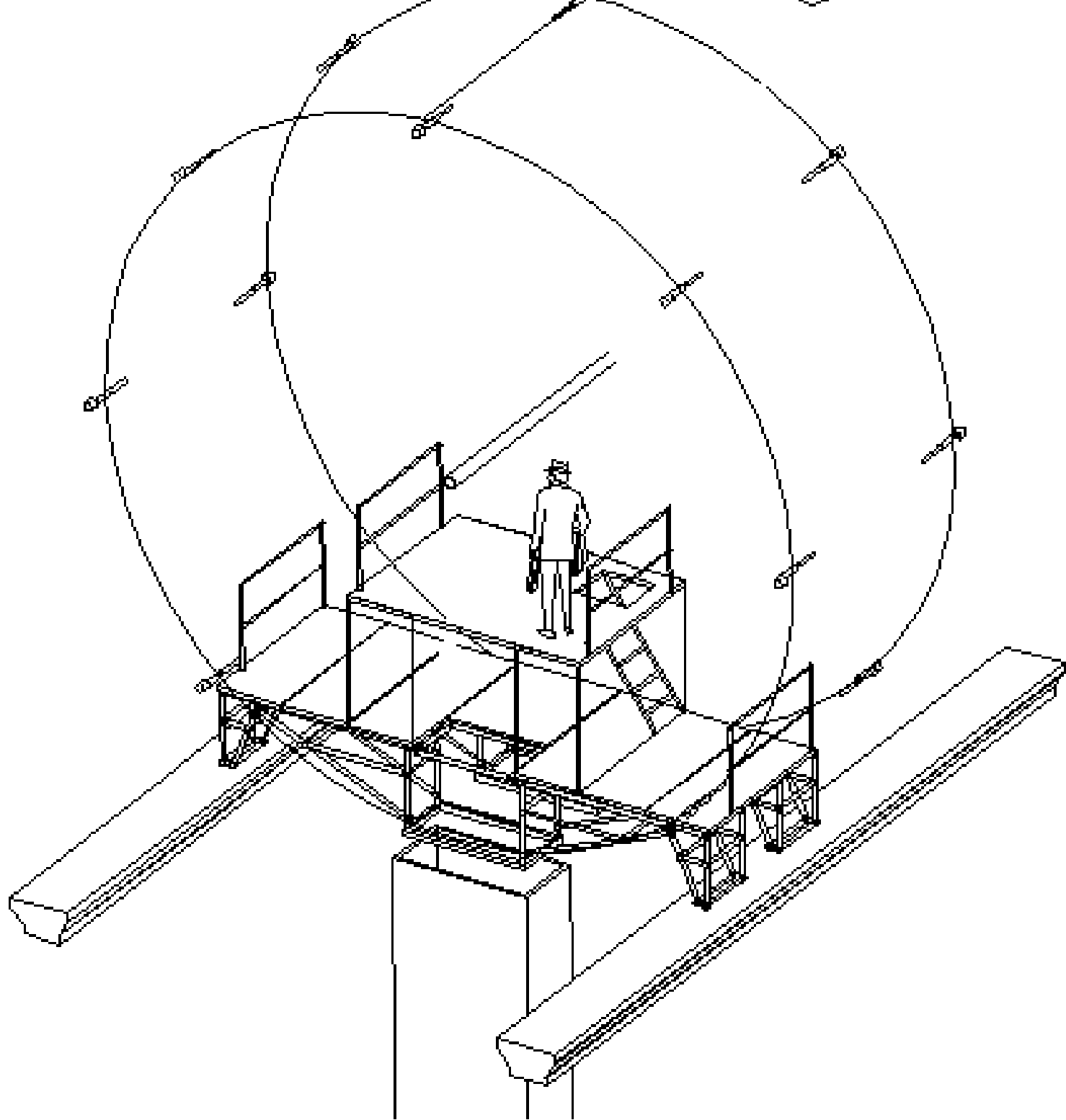

April 2007

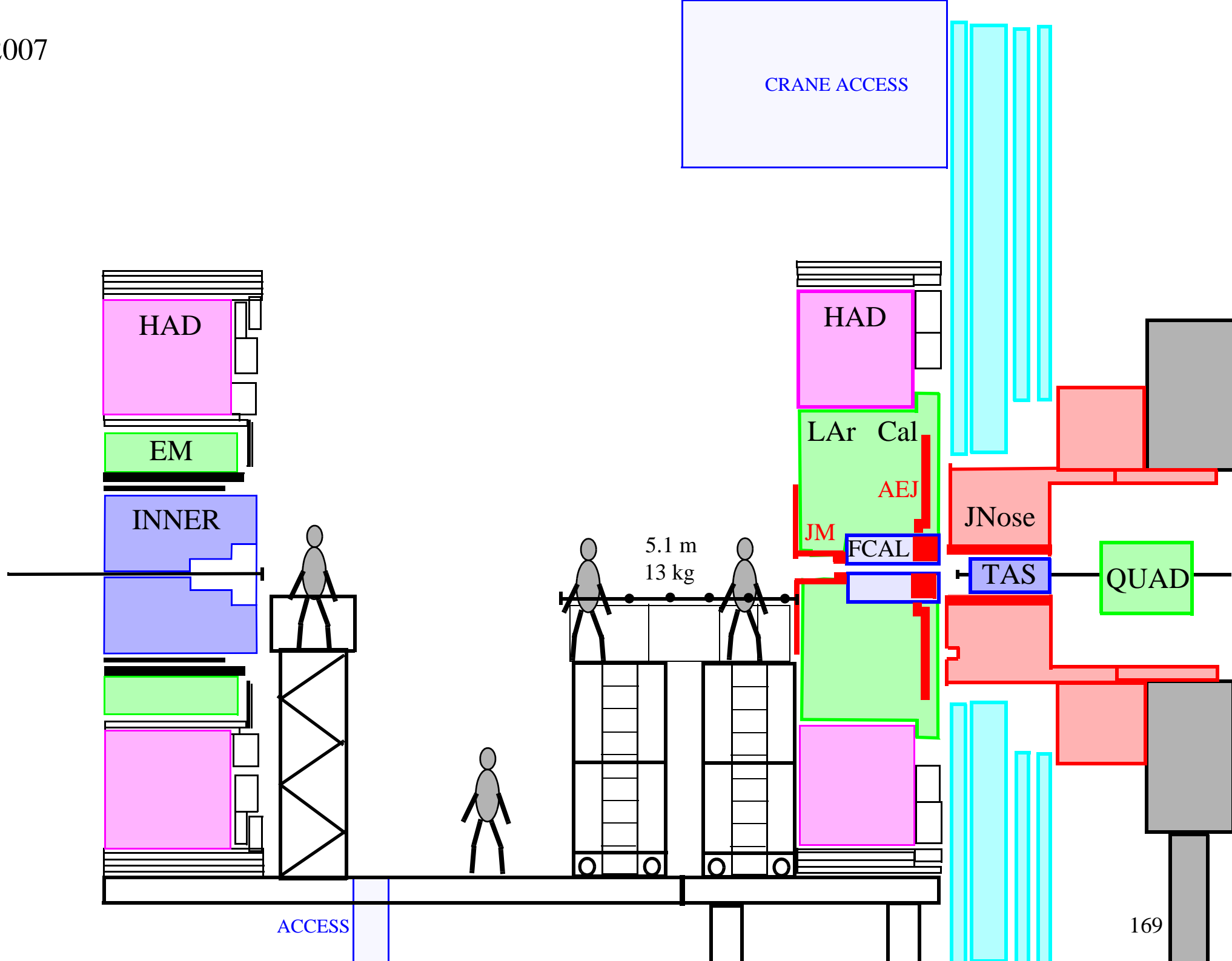

CRANE ACCESS

HAD

EM

INNER

HAD

LAr Cal

AEJ

JM

FCAL

JNose

TAS

QUAD

5.1 m
13 kg

ACCESS

169

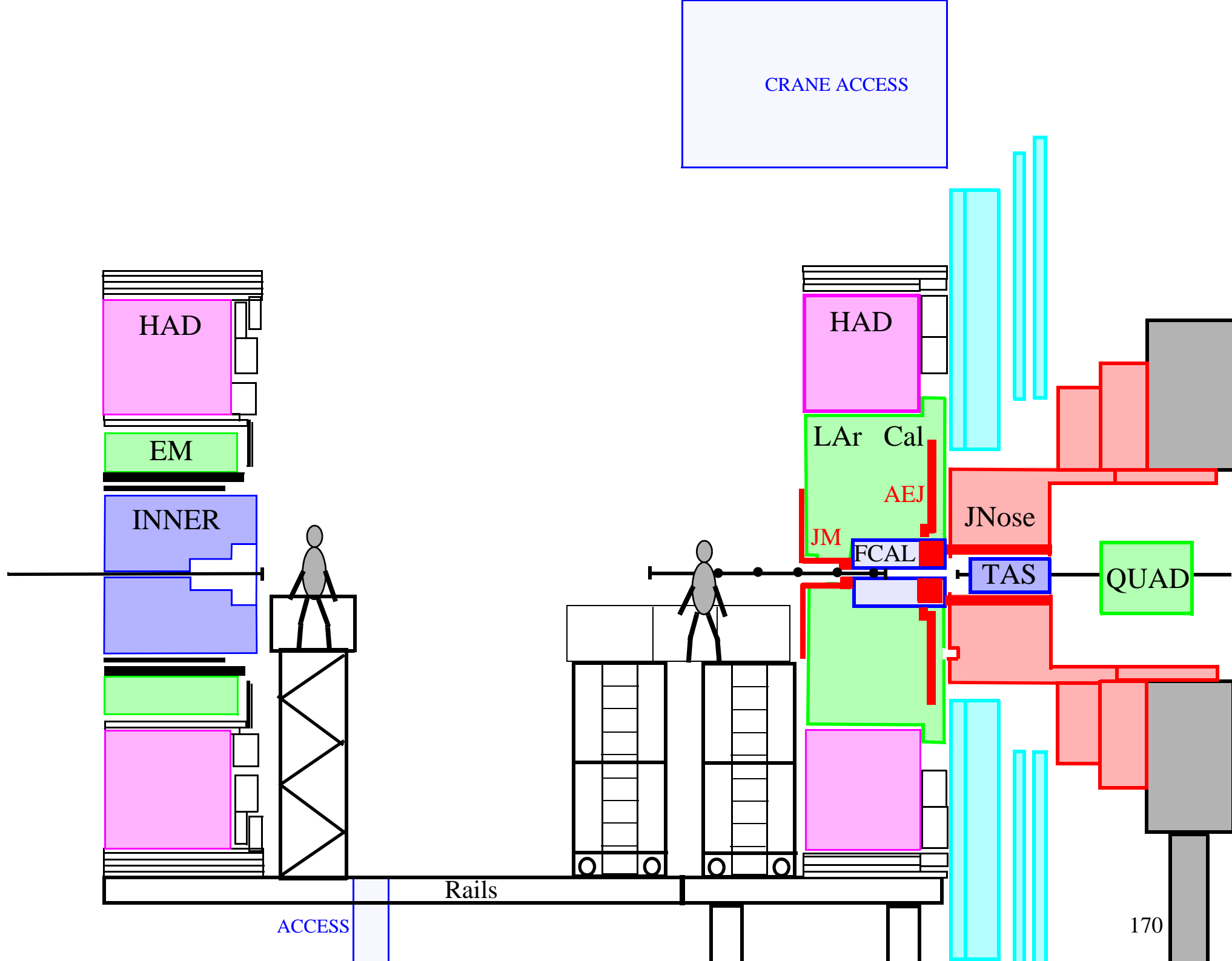

CRANE ACCESS

HAD

EM

INNER

HAD

LAr Cal

AEJ

JM

FCAL

JNose

TAS

QUAD

RAILS

ACCESS

170

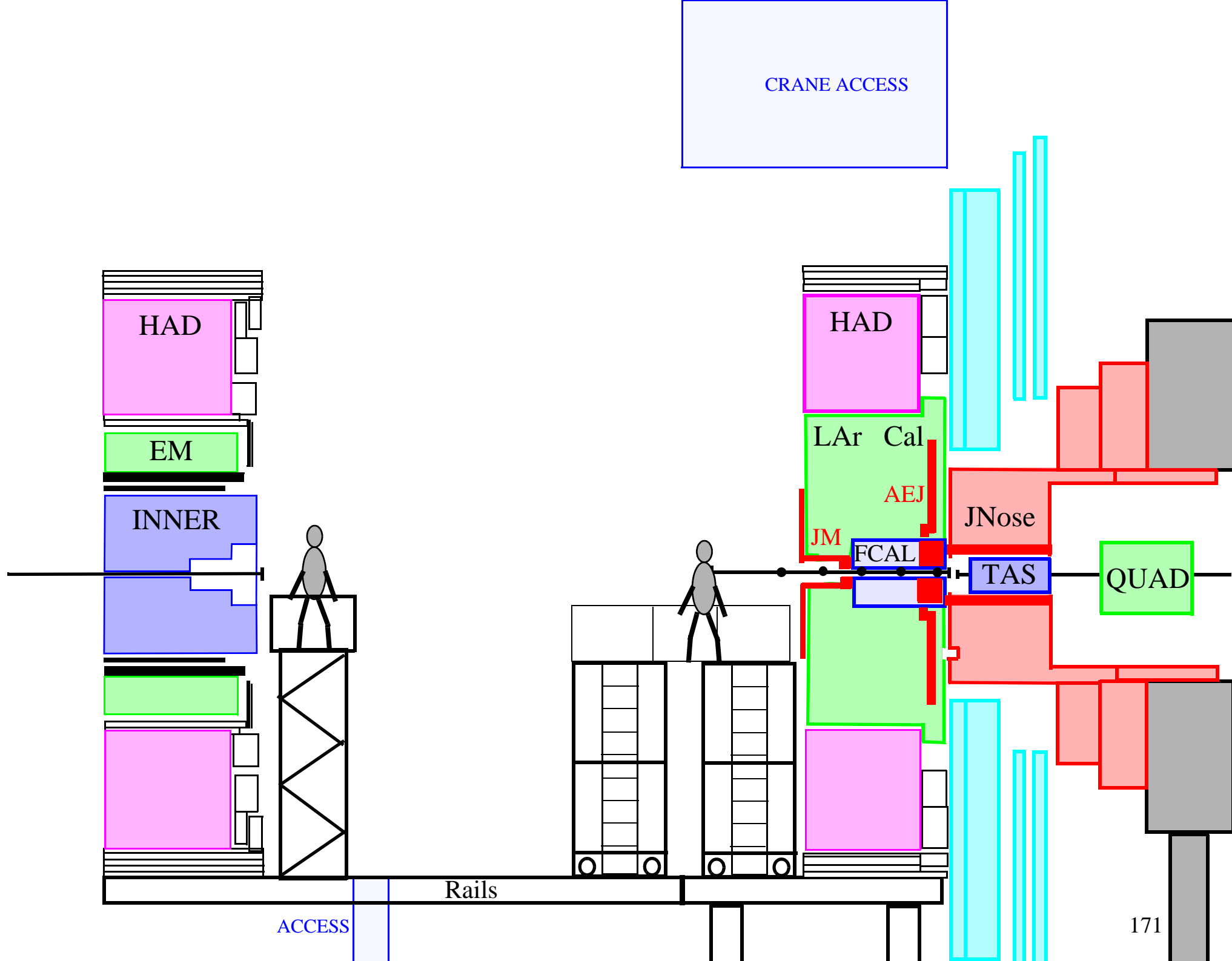

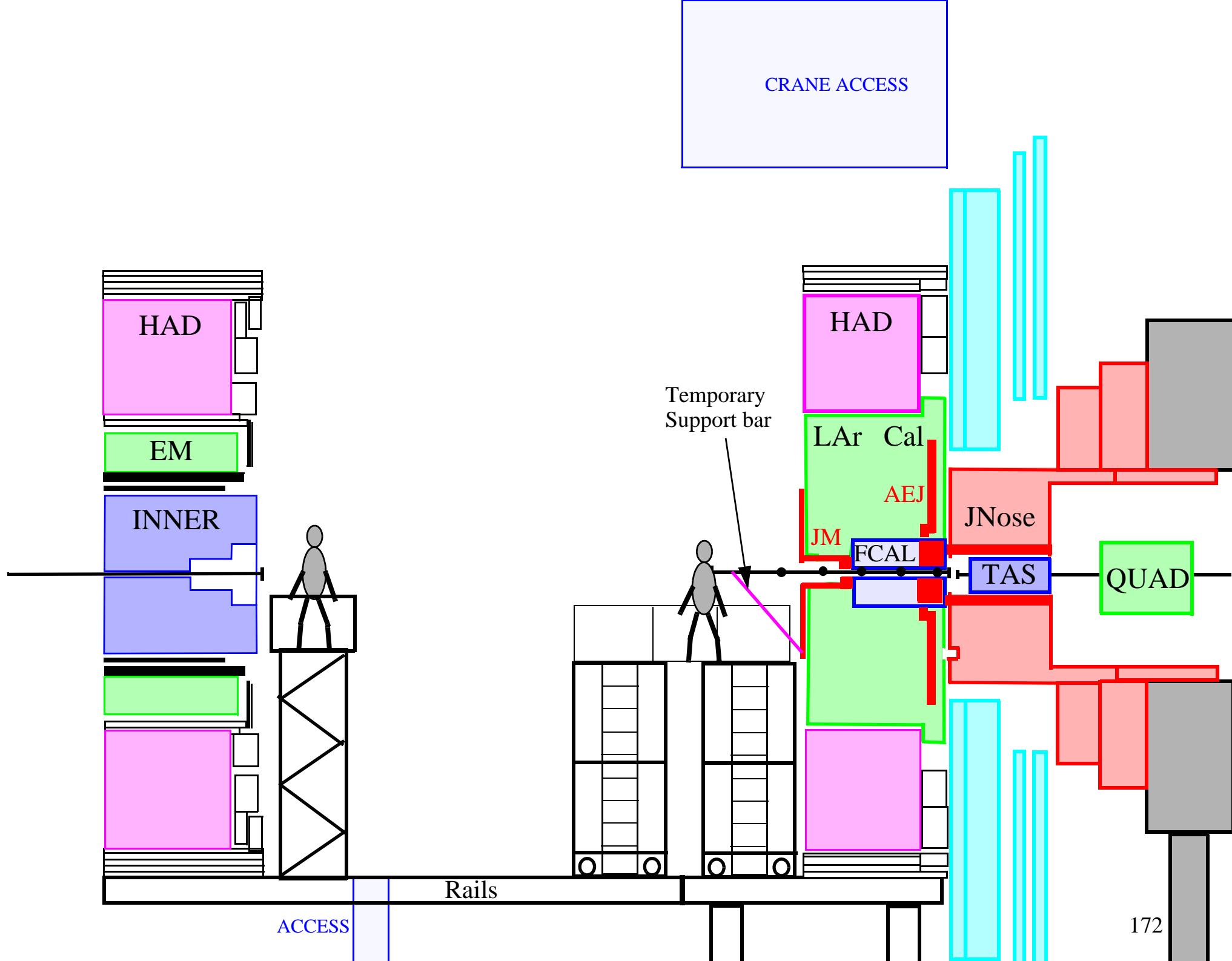

CRANE ACCESS

HAD

EM

INNER

HAD

LAr Cal

AEJ

JM

FCAL

JNose

TAS

QUAD

Temporary Support bar

Rails

ACCESS

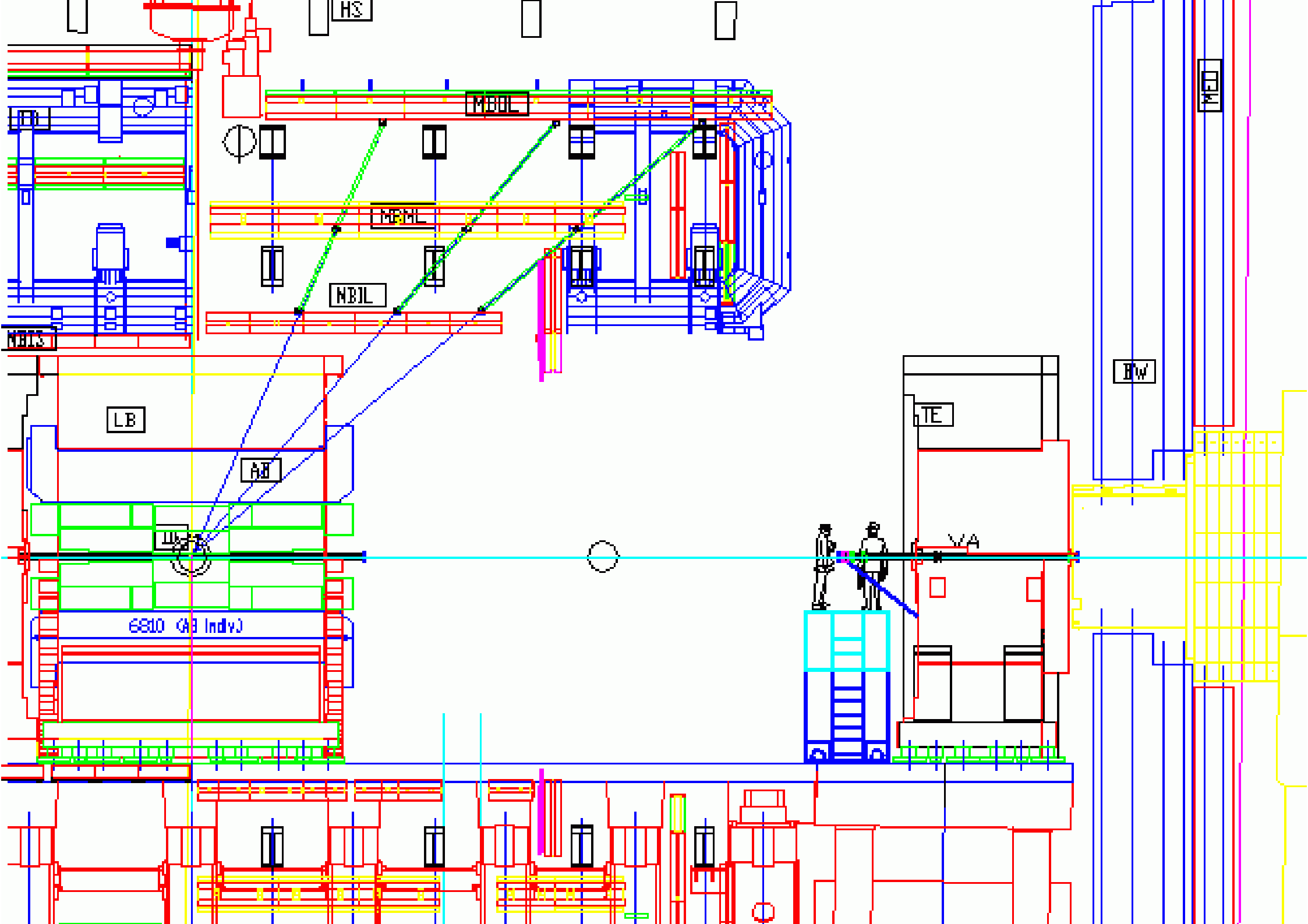

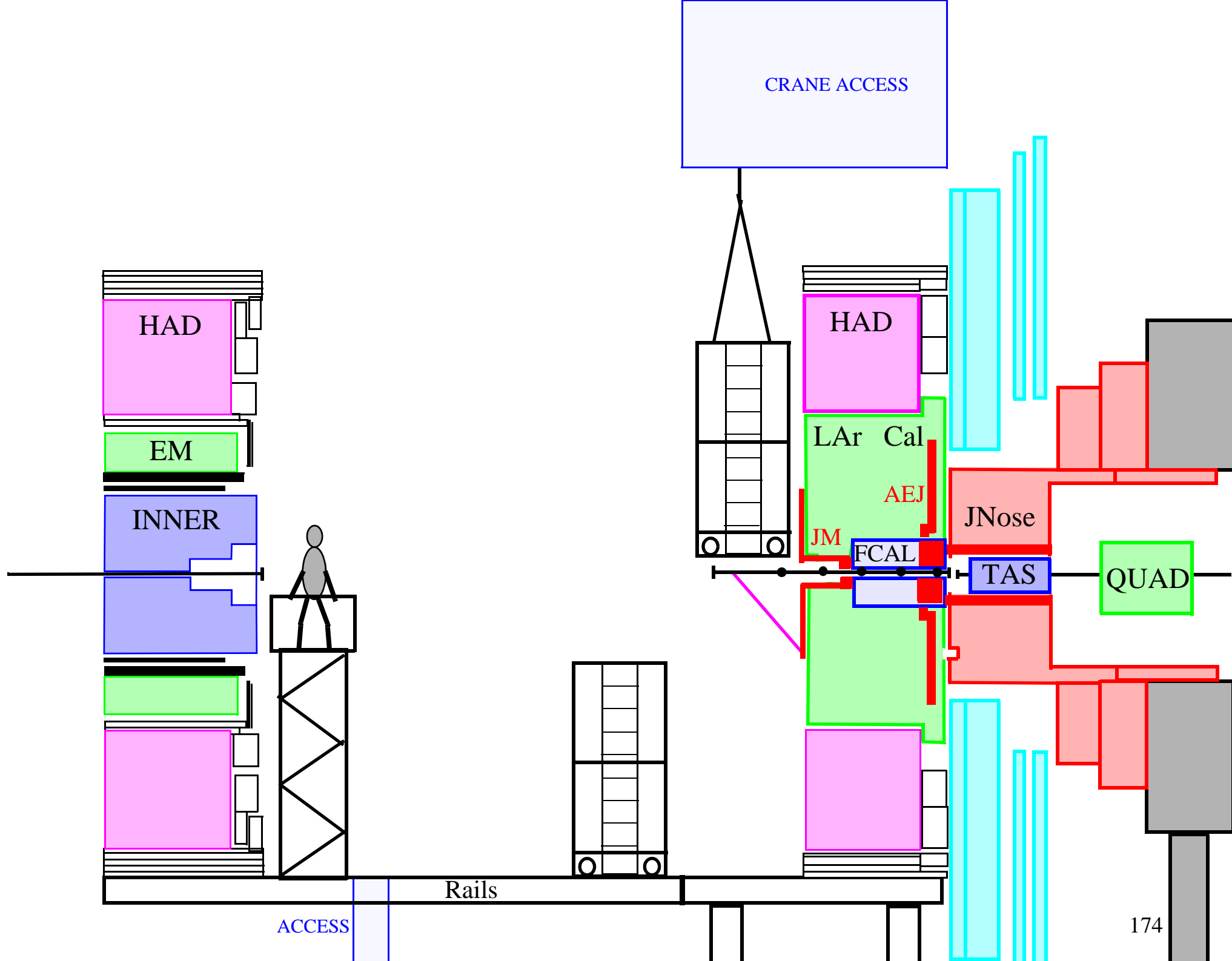

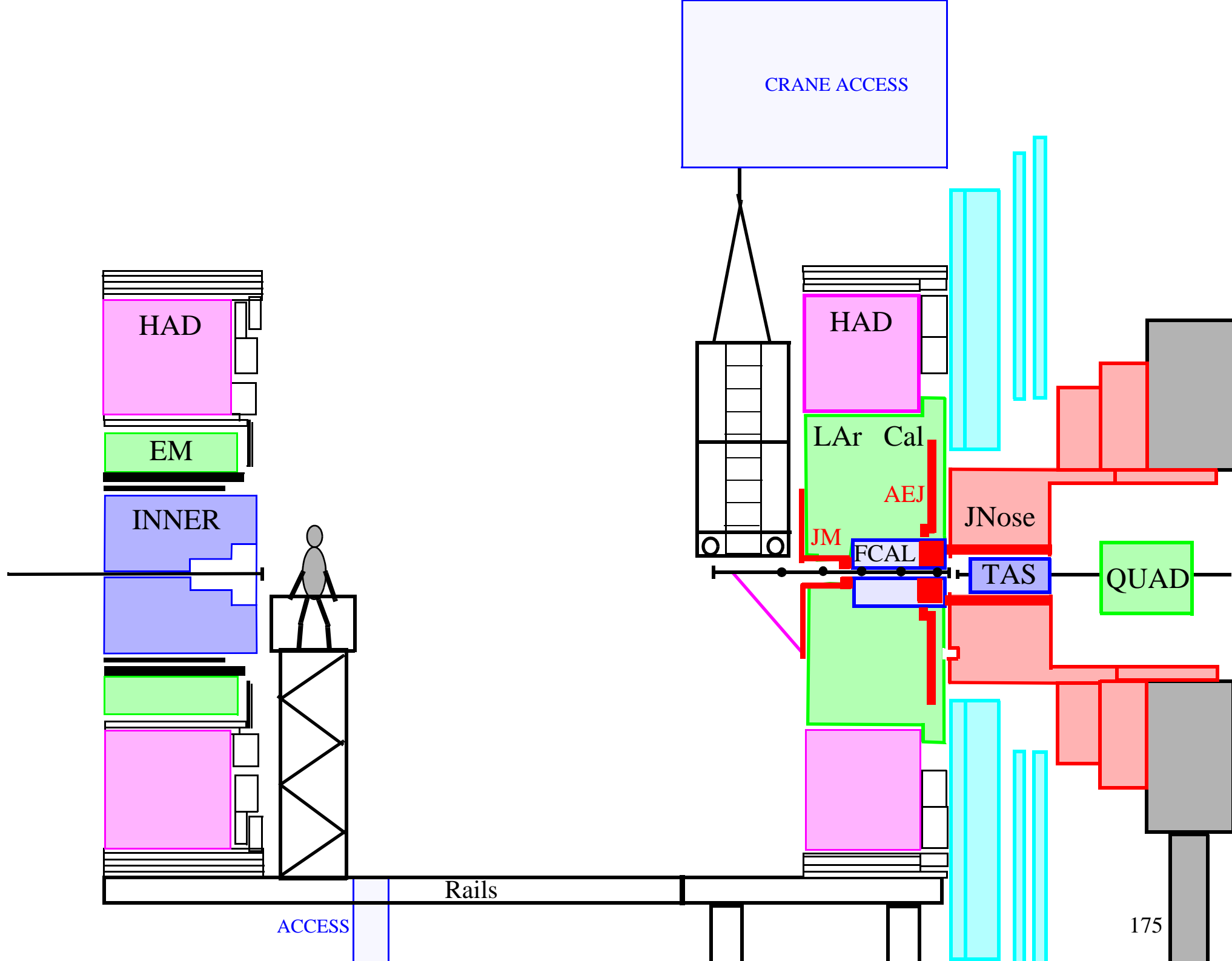

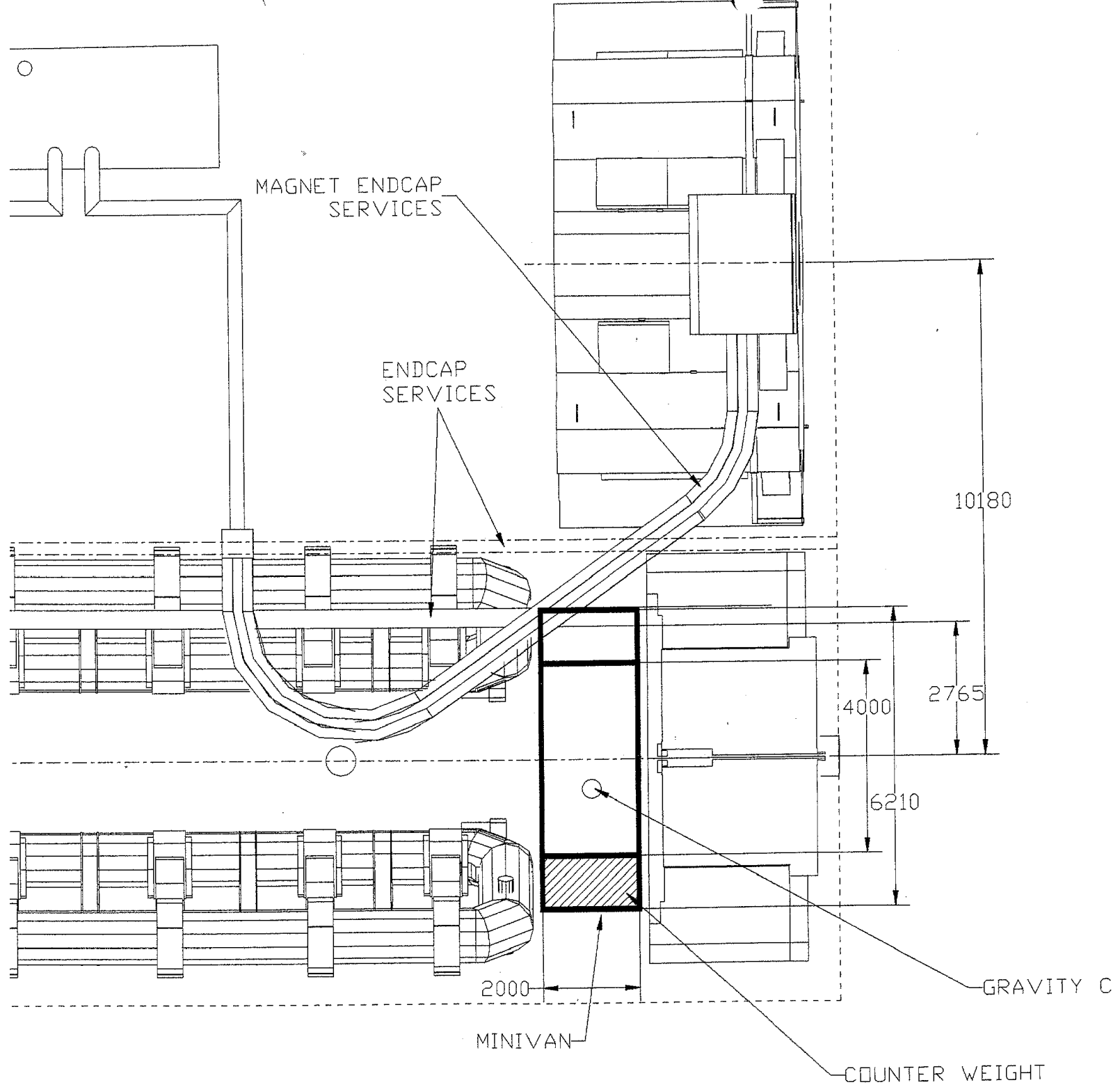

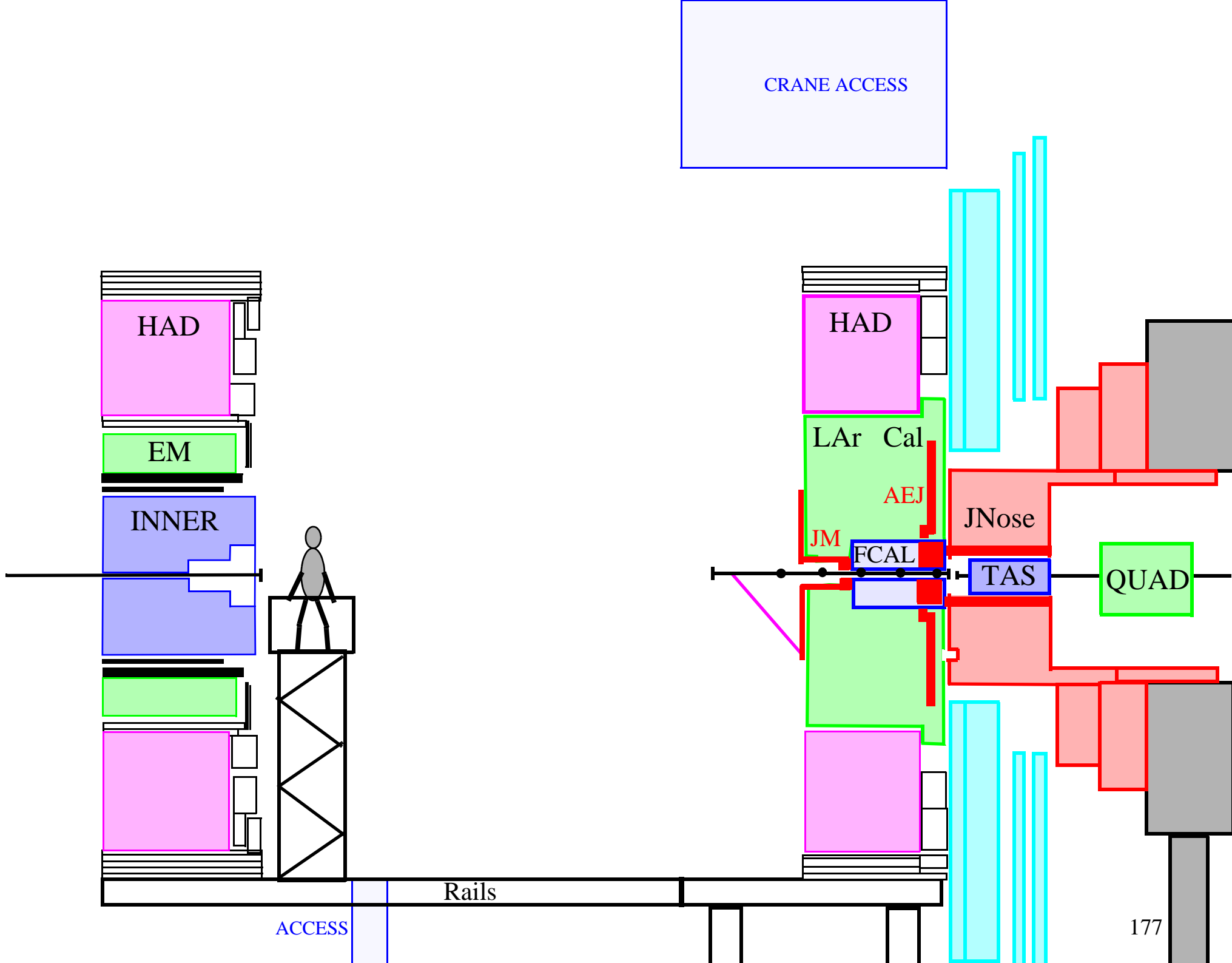

CRANE ACCESS

HAD

EM

INNER

HAD

LAr Cal

AEJ

JM

FCAL

JNose

TAS

QUAD

RAILS

ACCESS

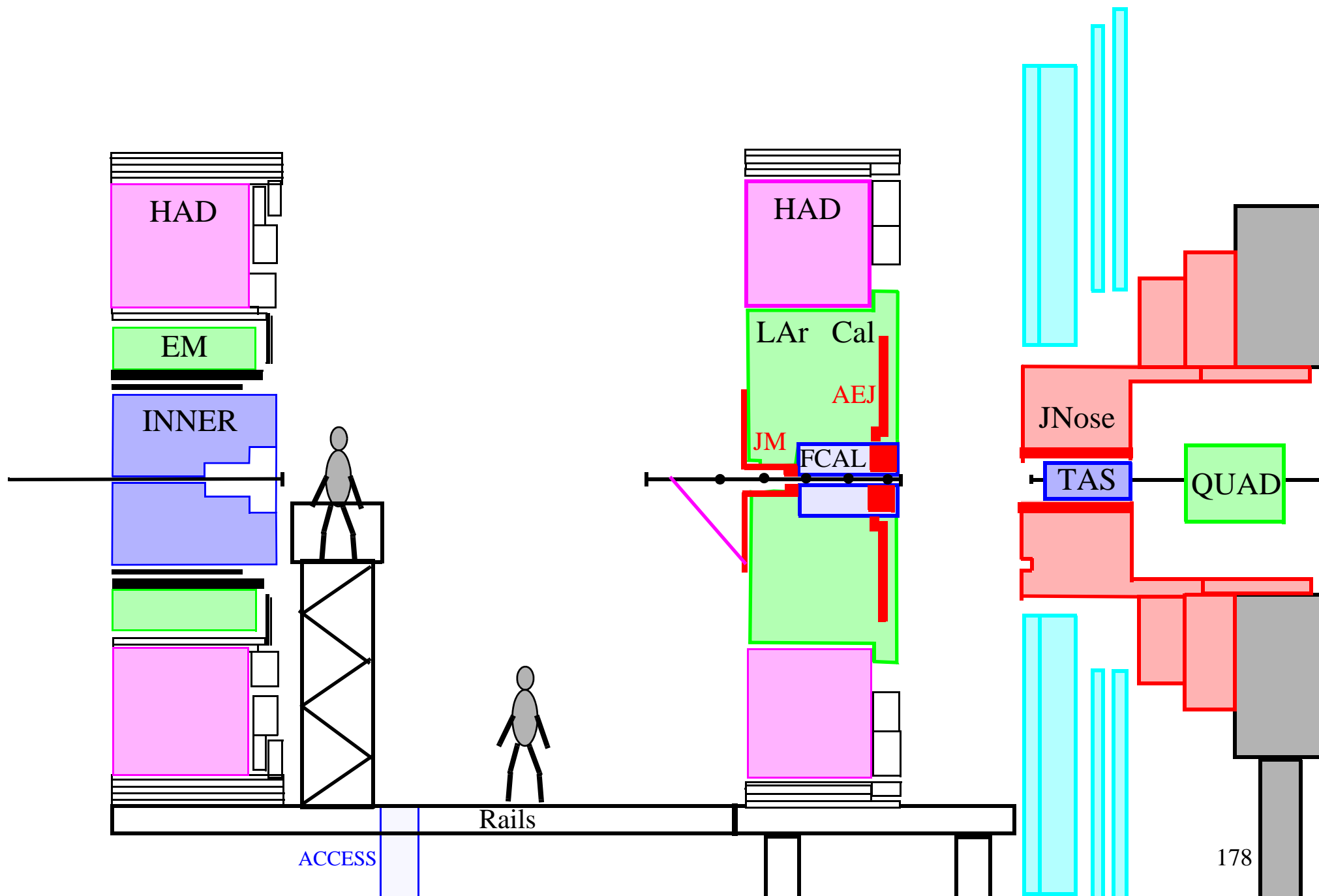

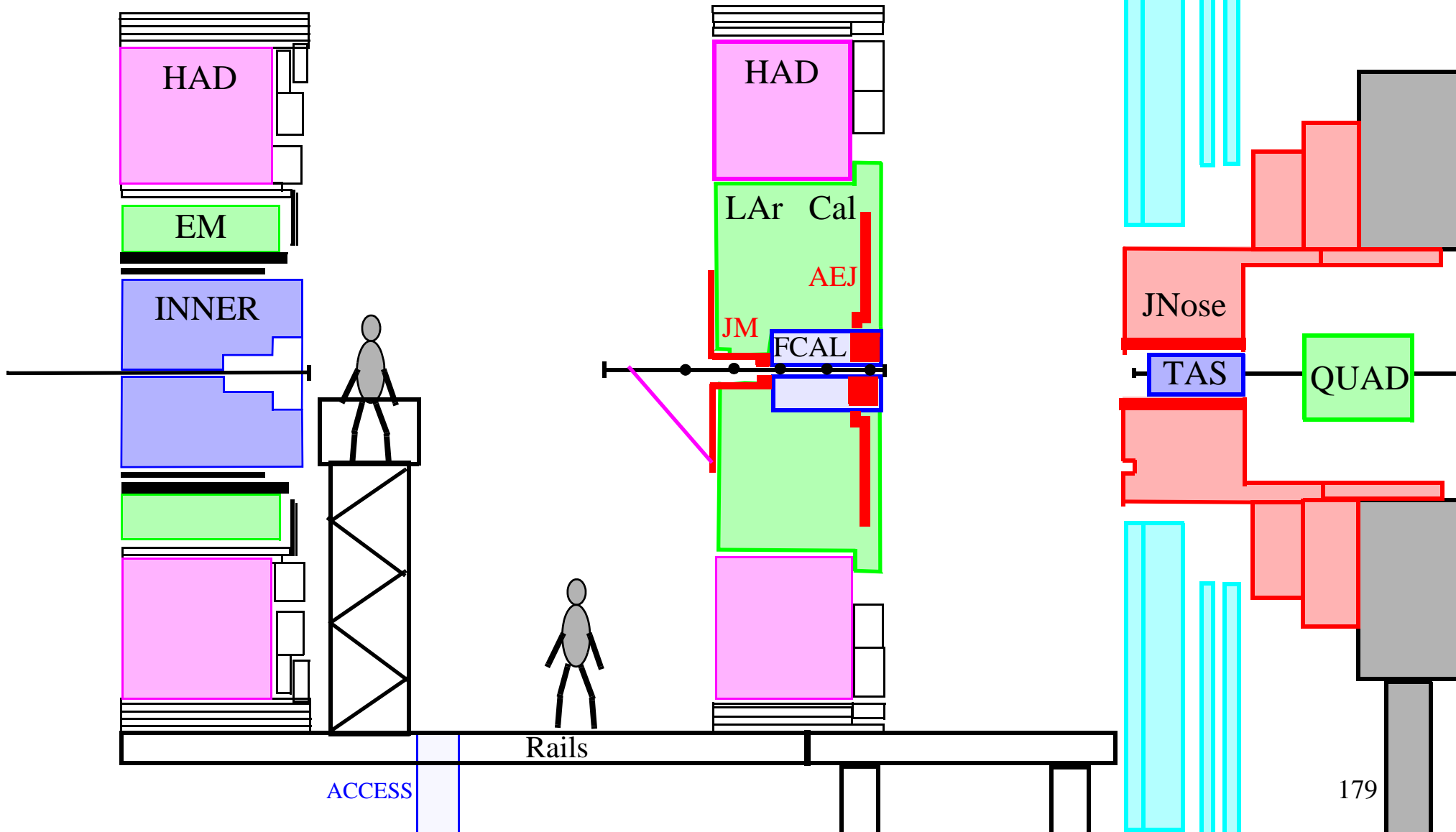

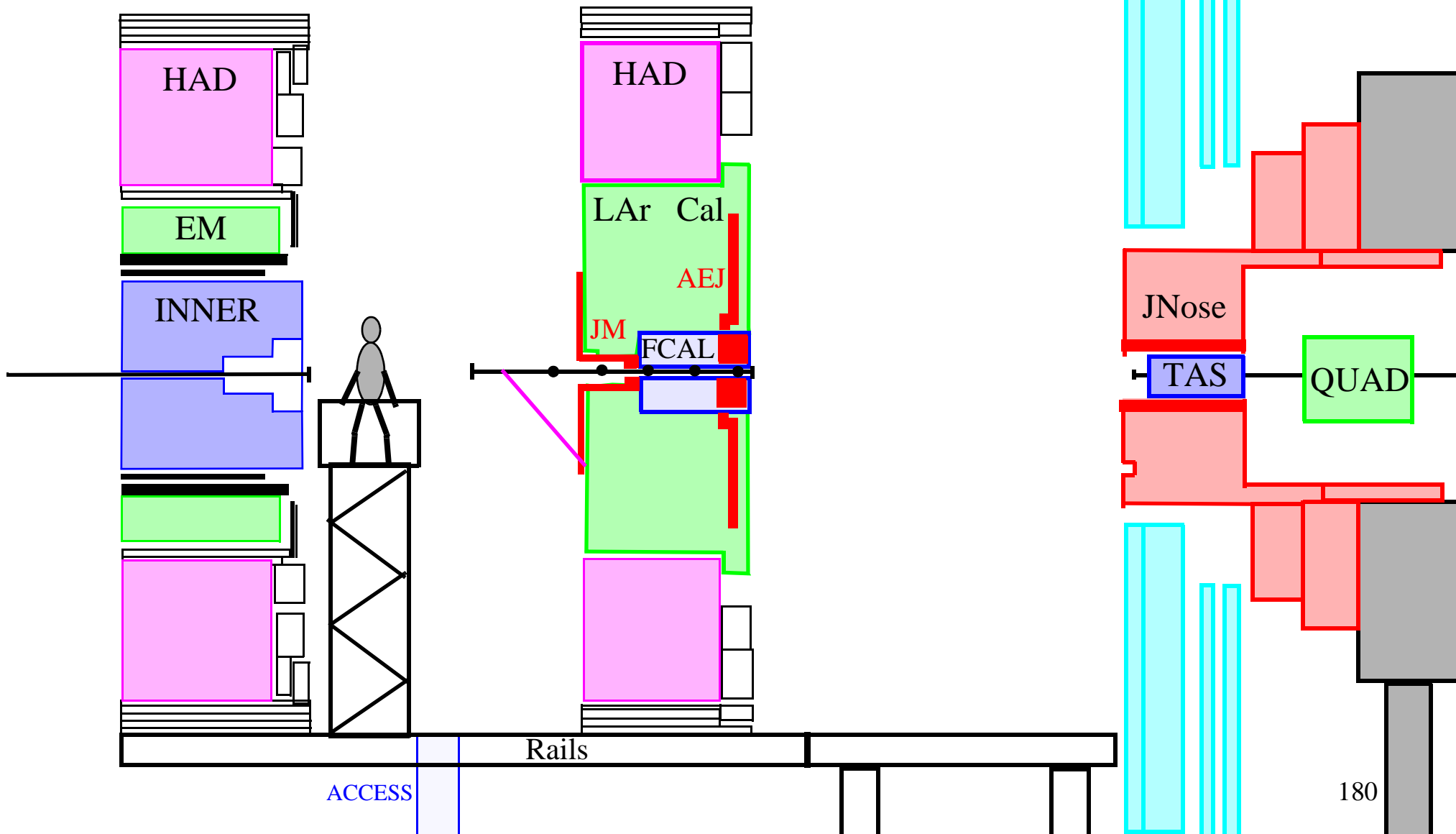

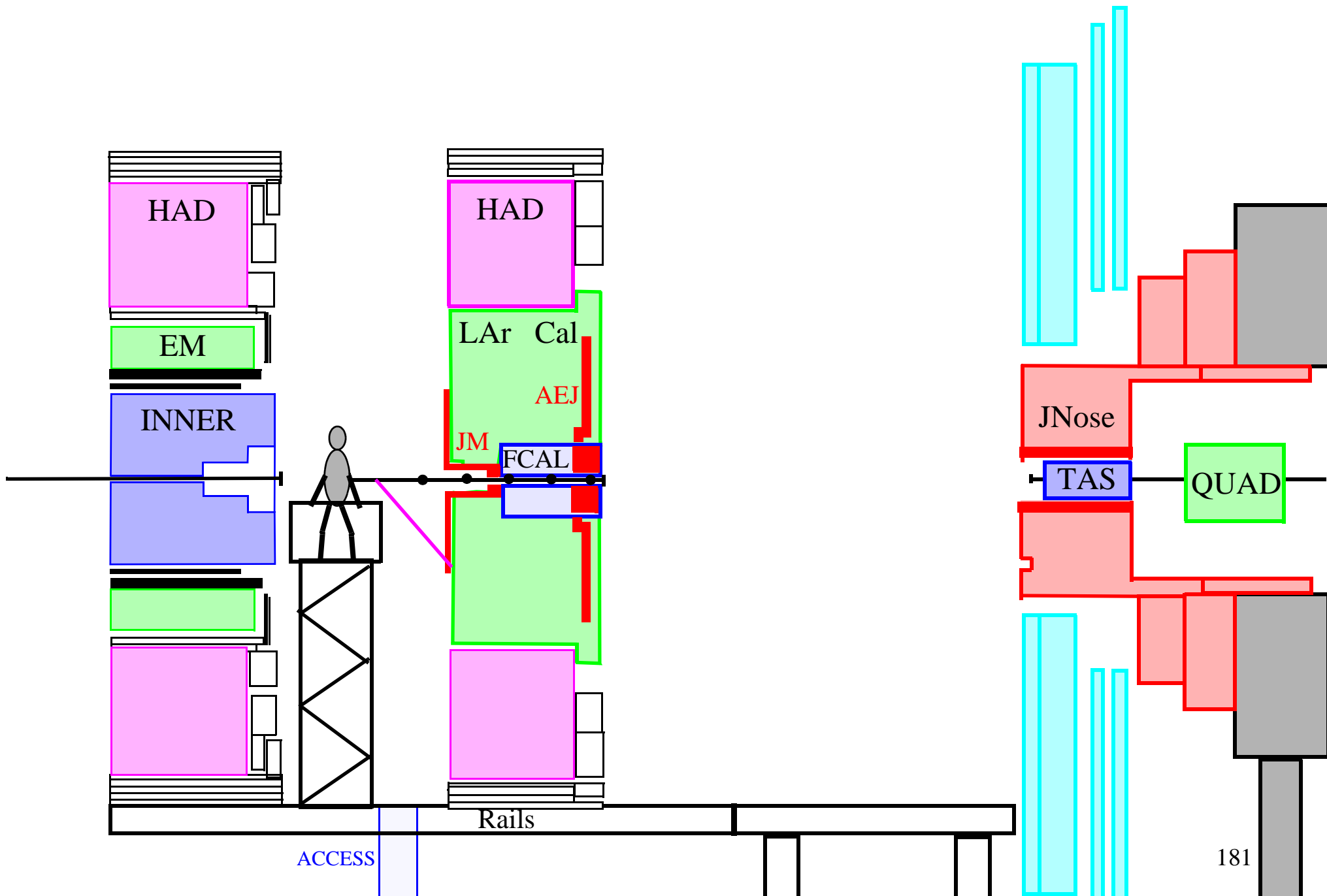

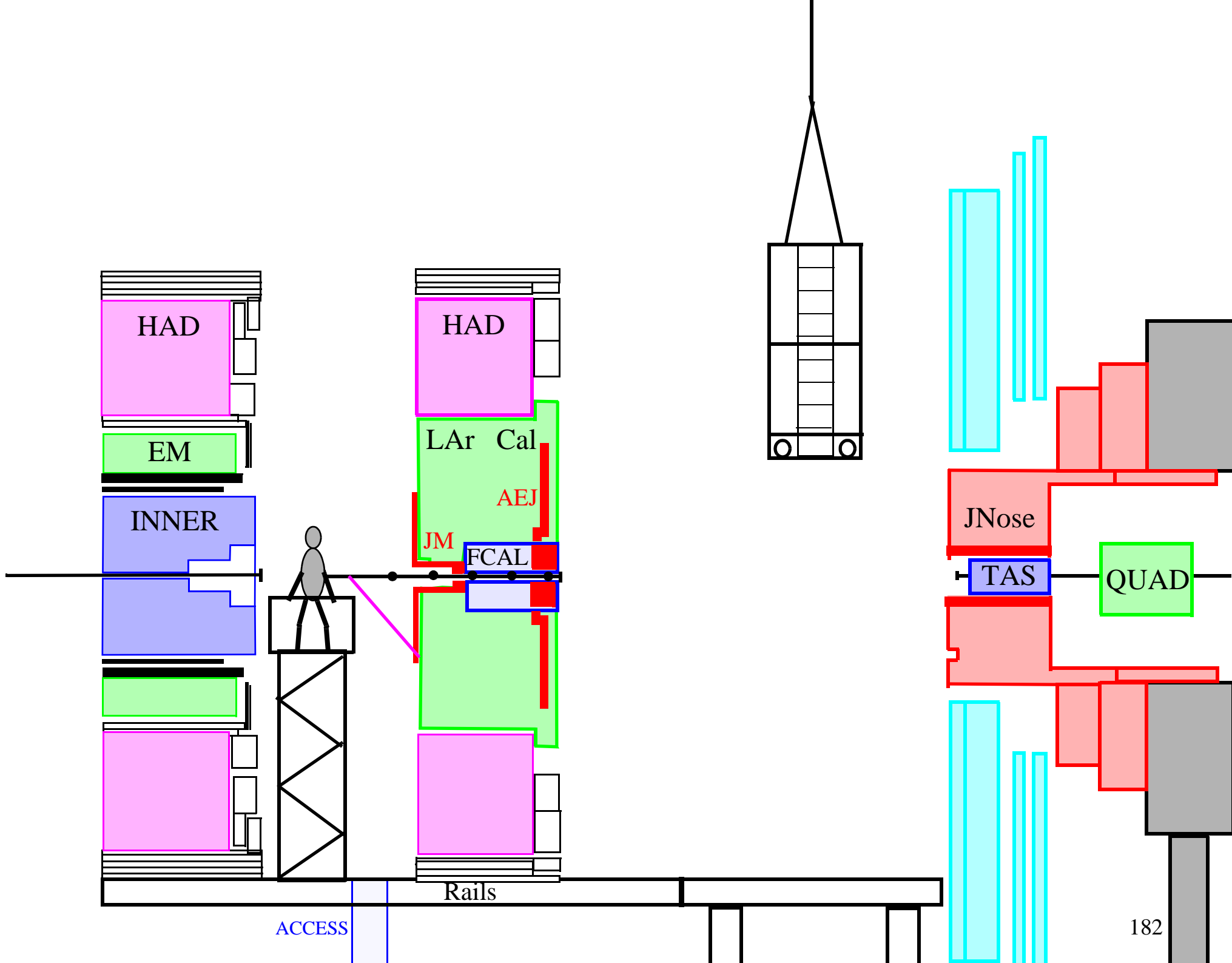

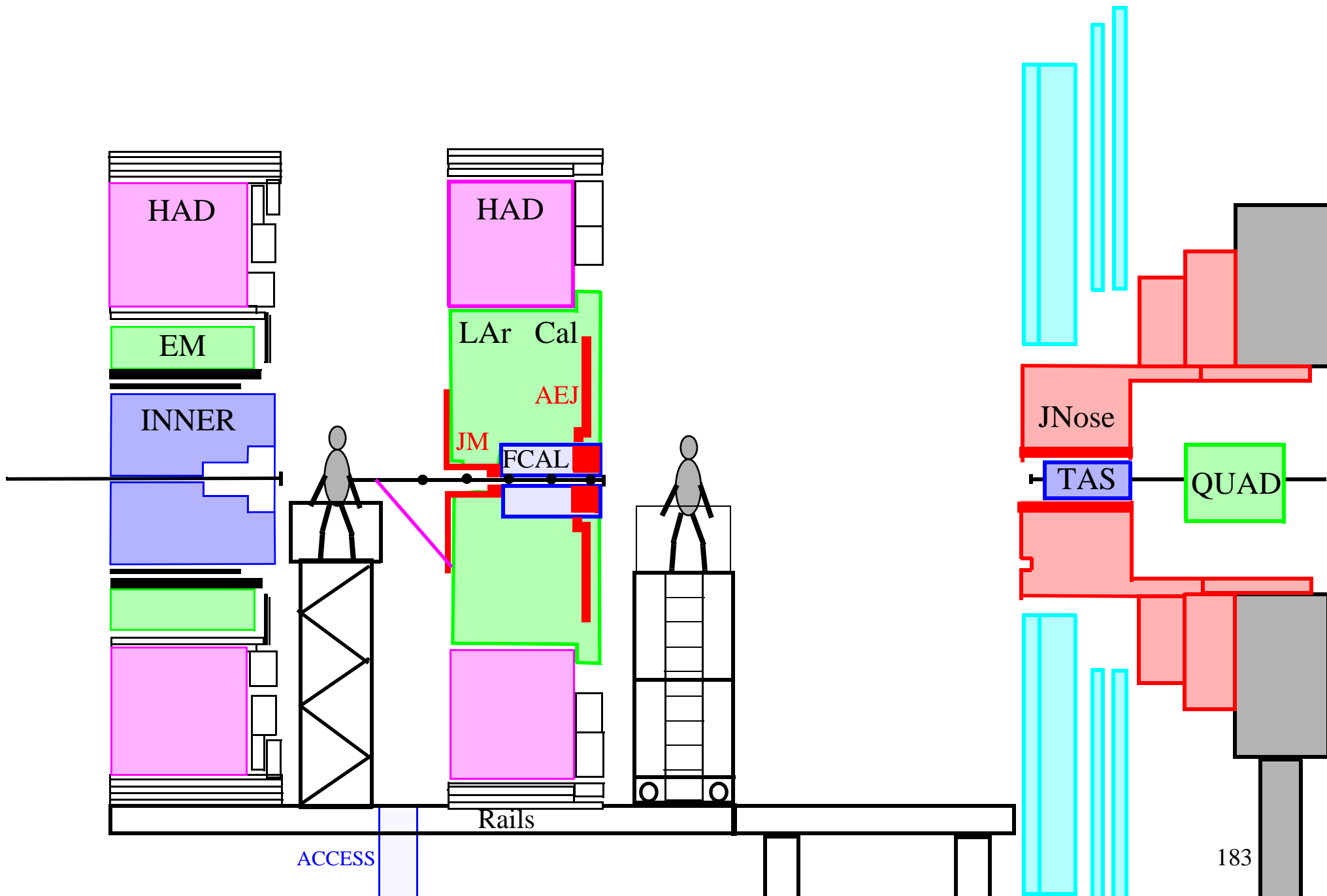

ACCESS

Rails

HAD

EM

INNER

HAD

LAr Cal

AEJ

JM

FCAL

JNose

TAS

QUAD

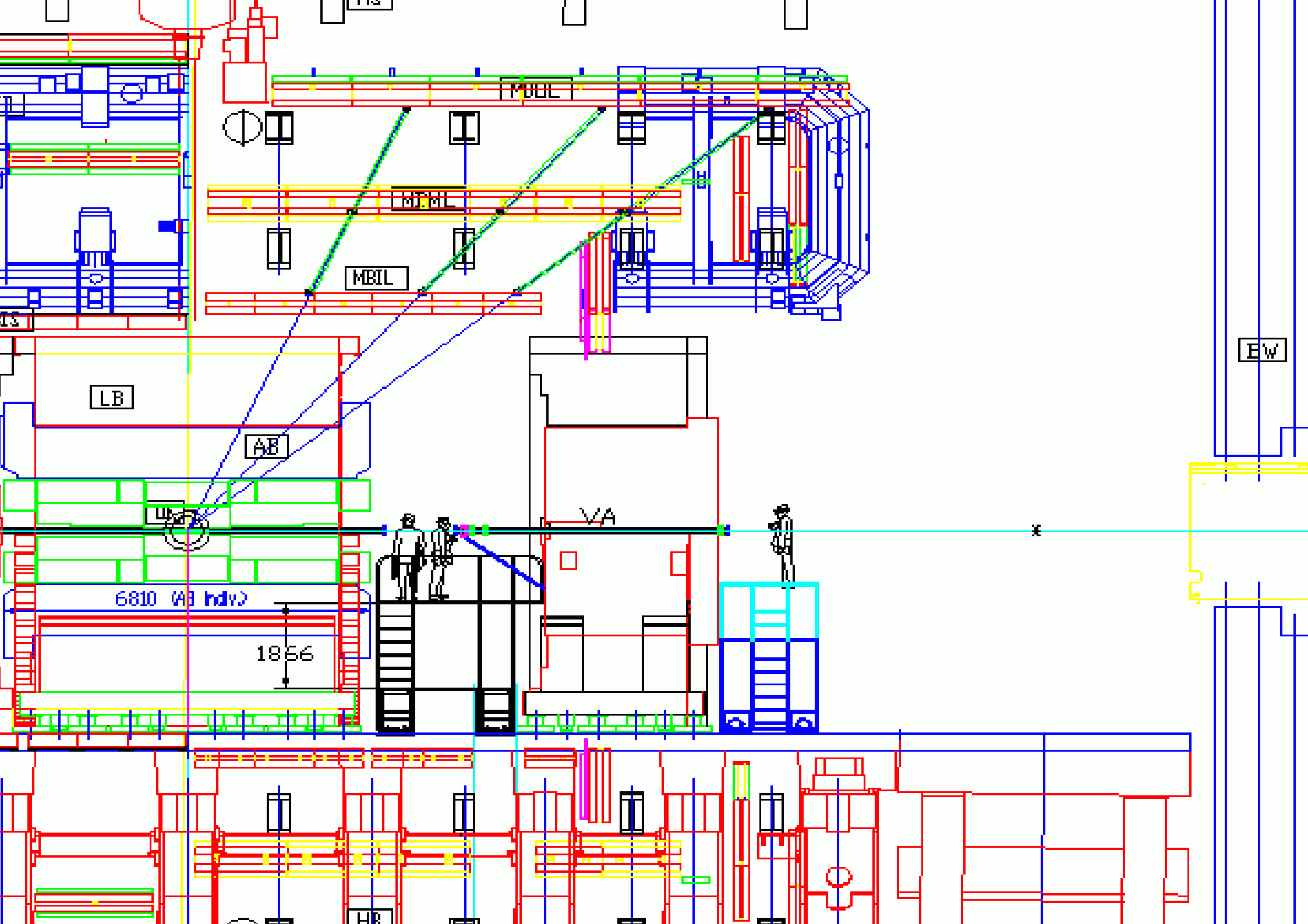

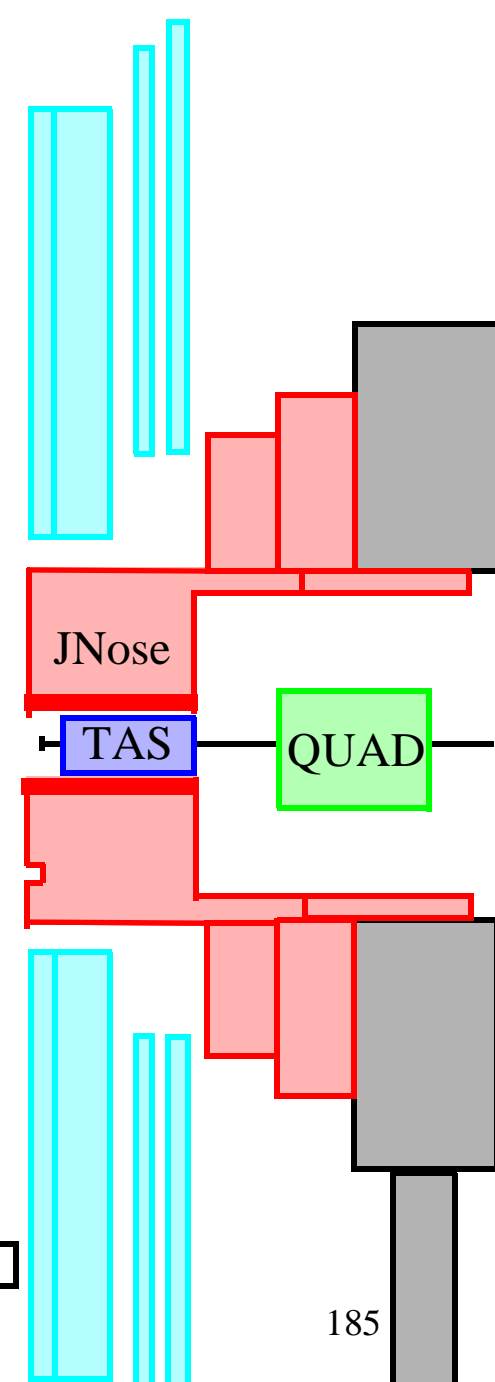
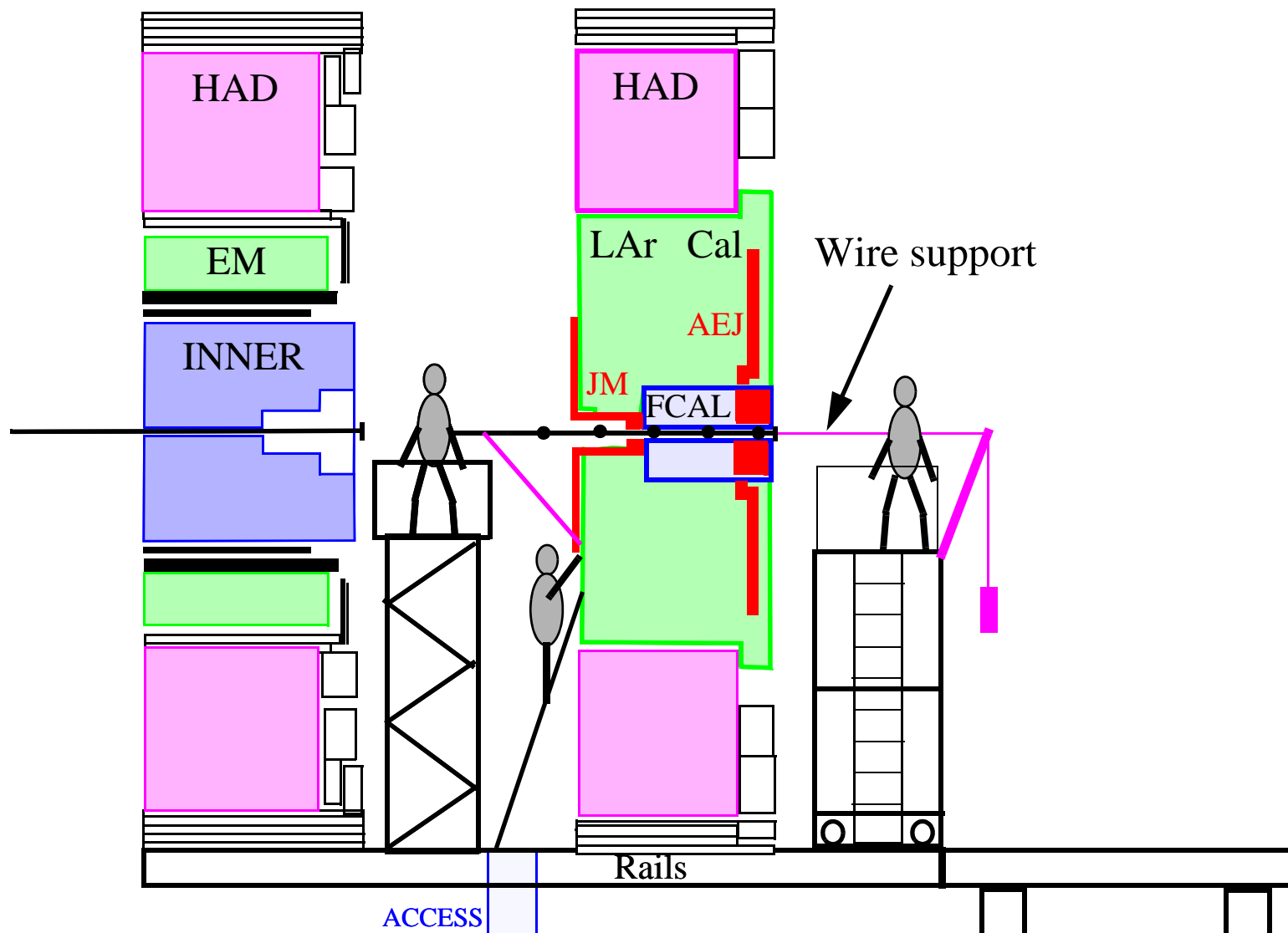

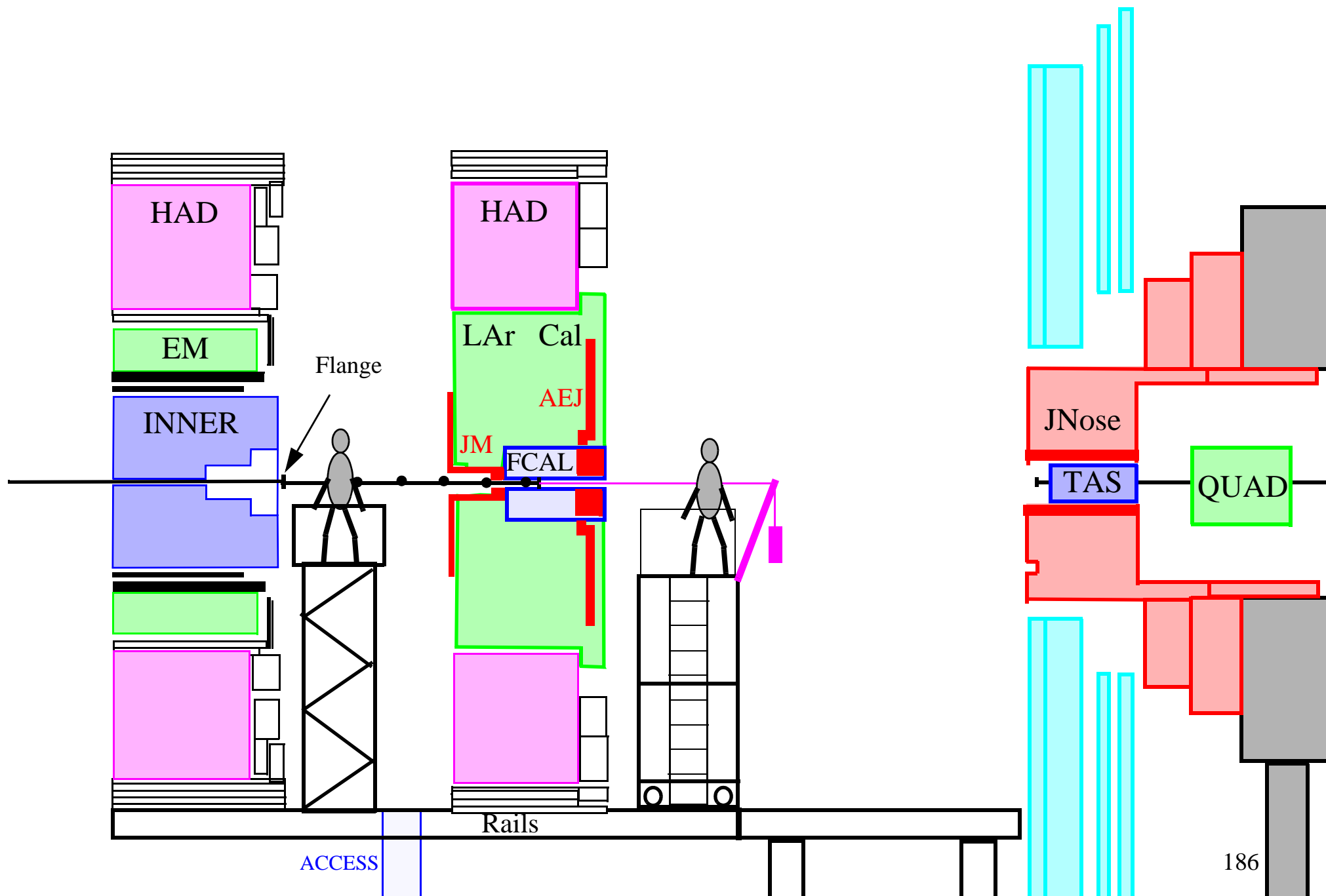

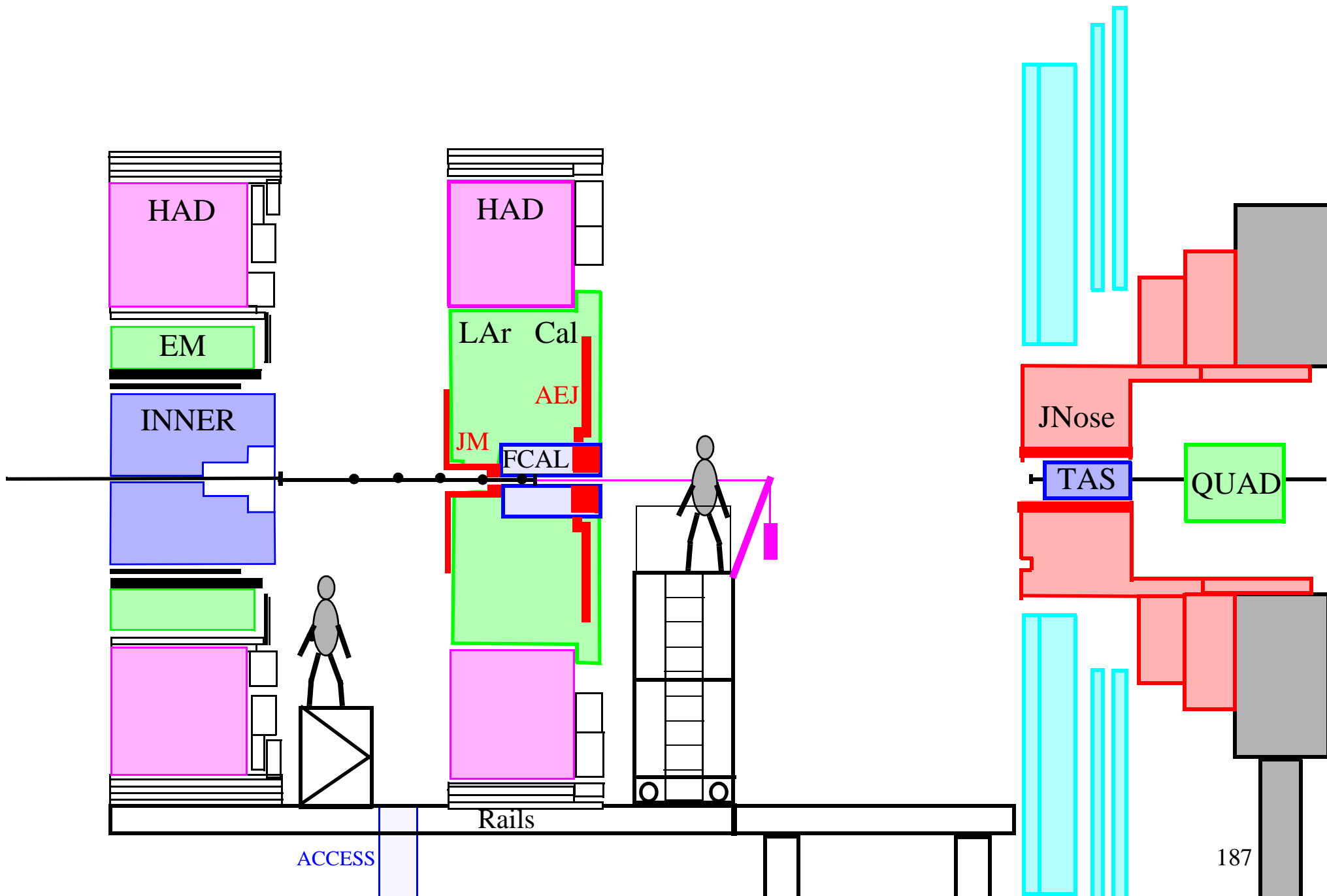

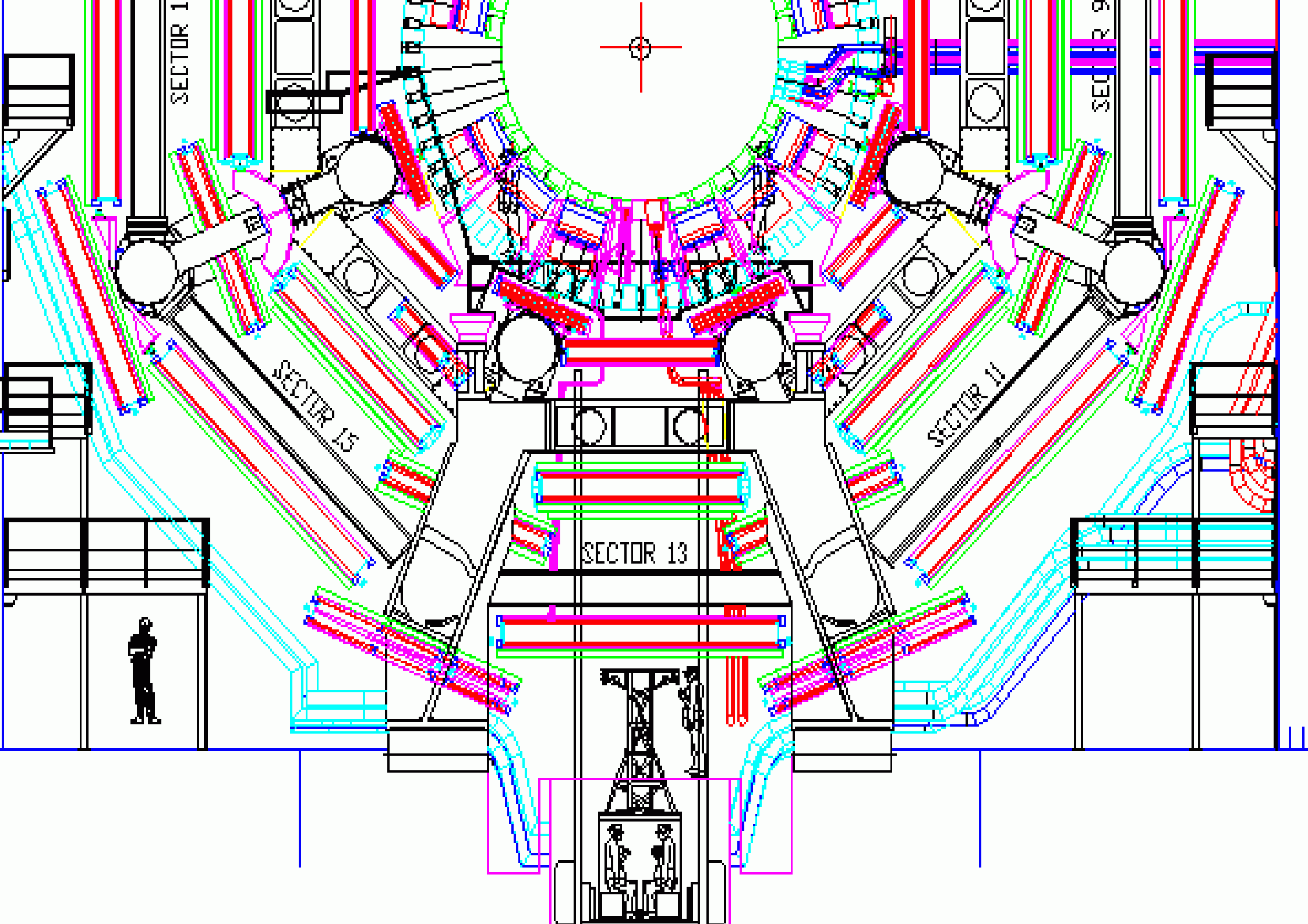

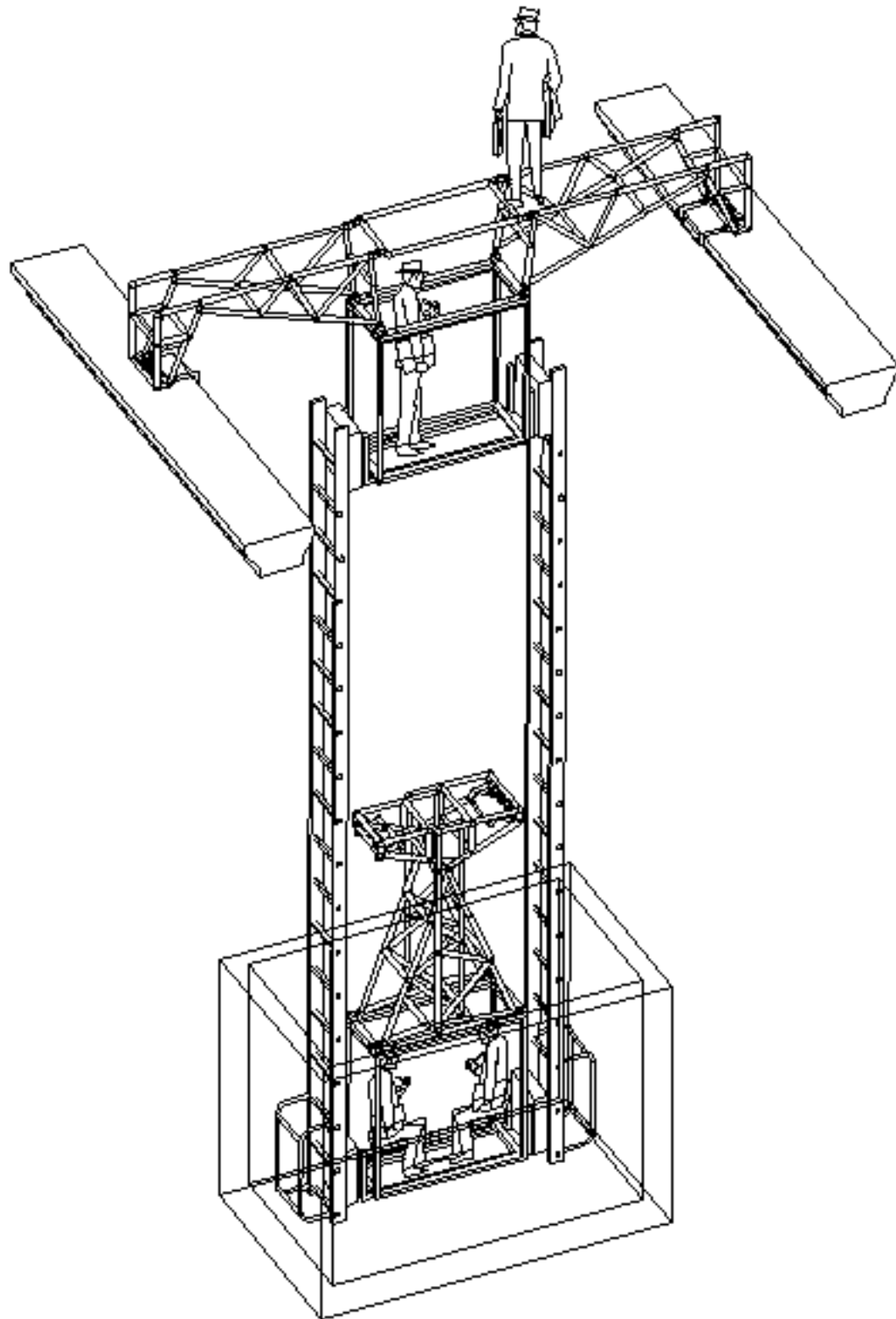

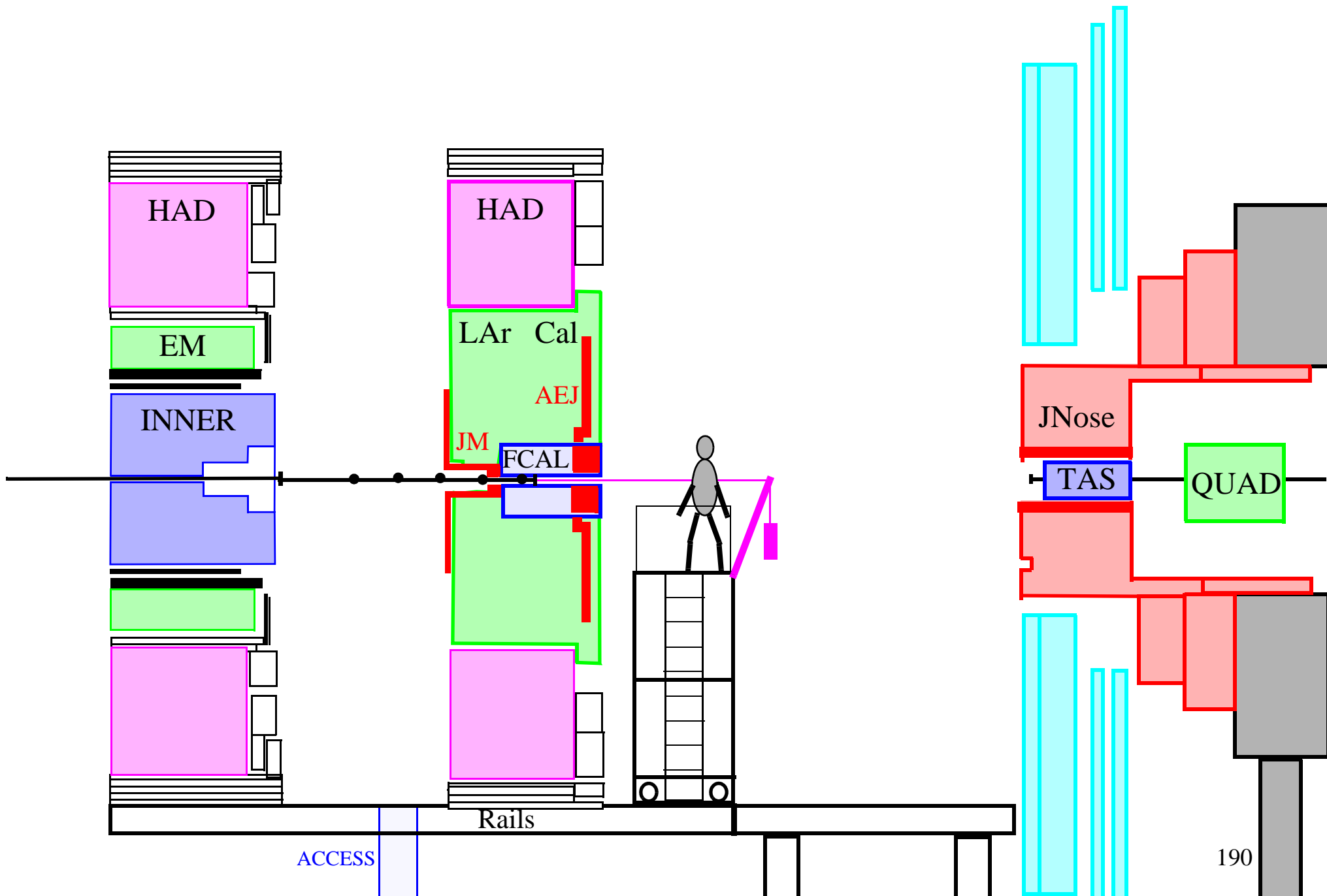

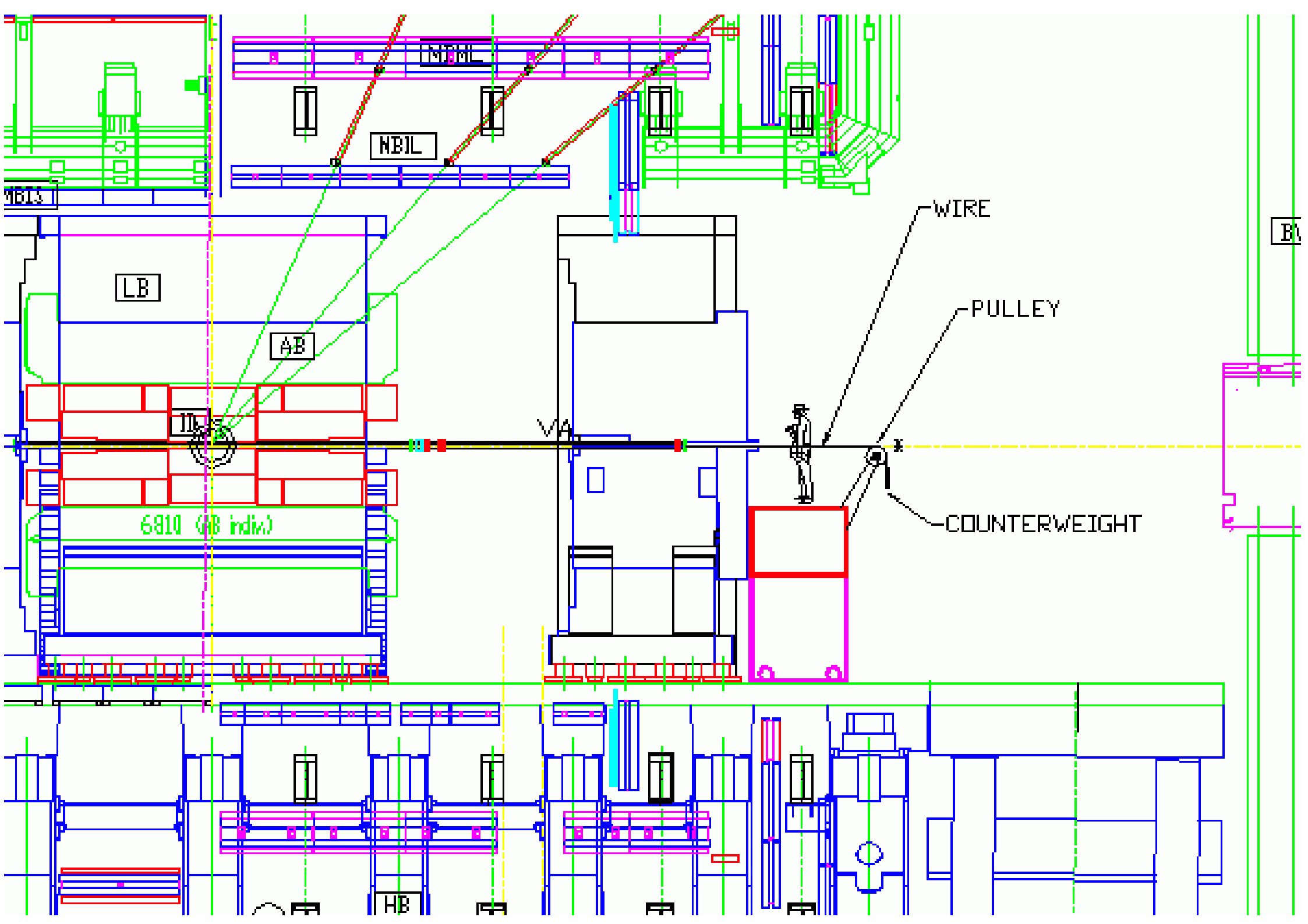

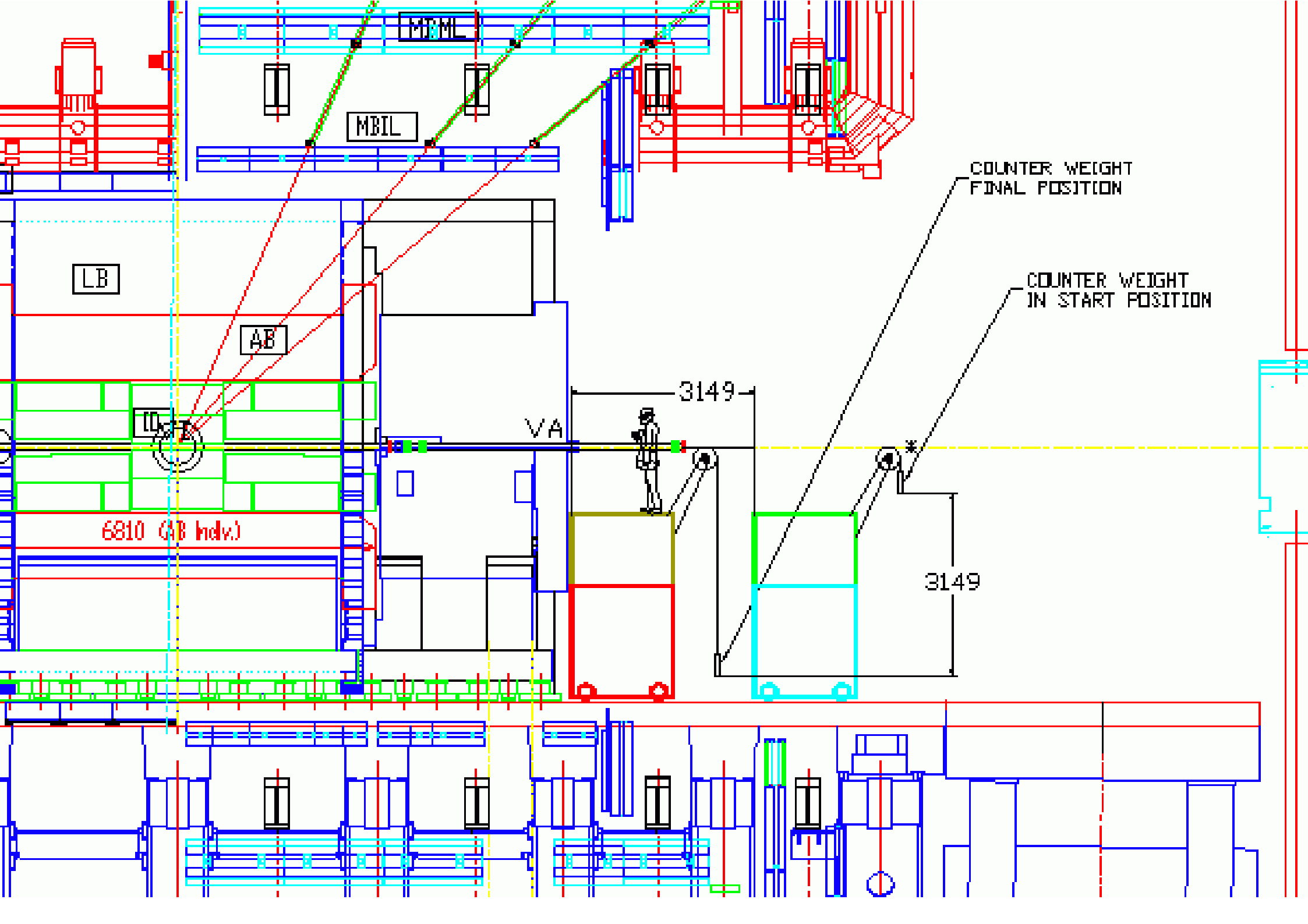

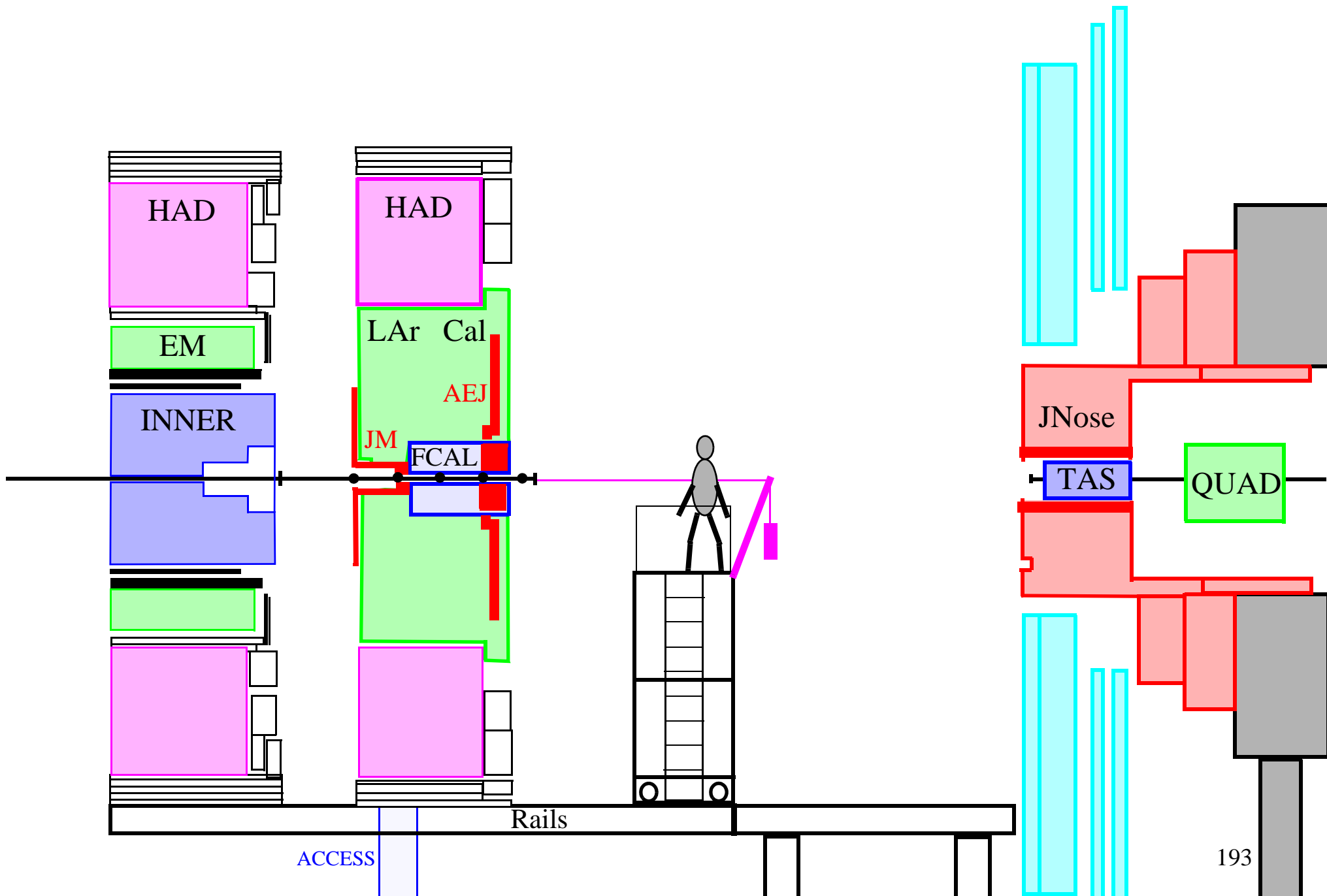

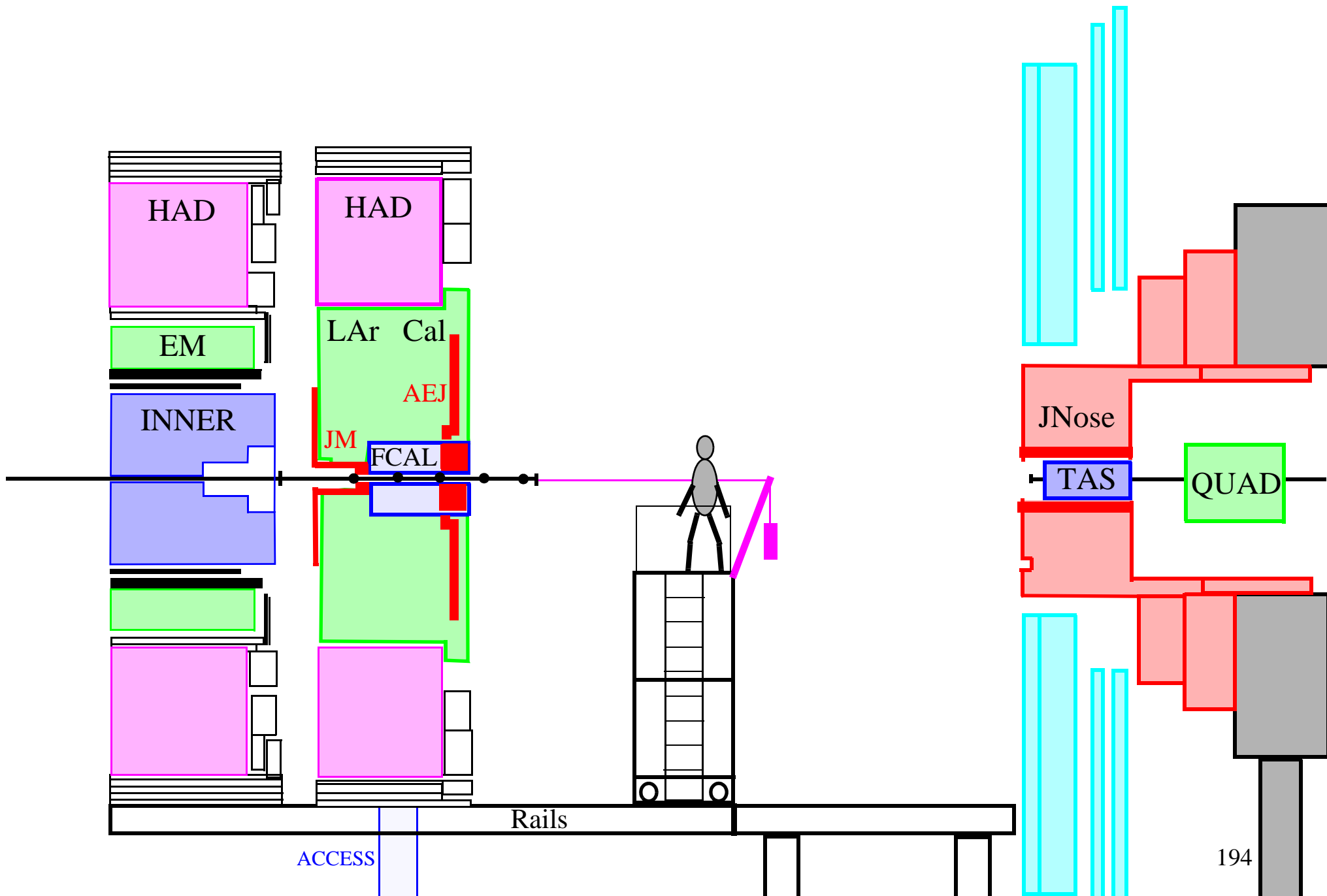

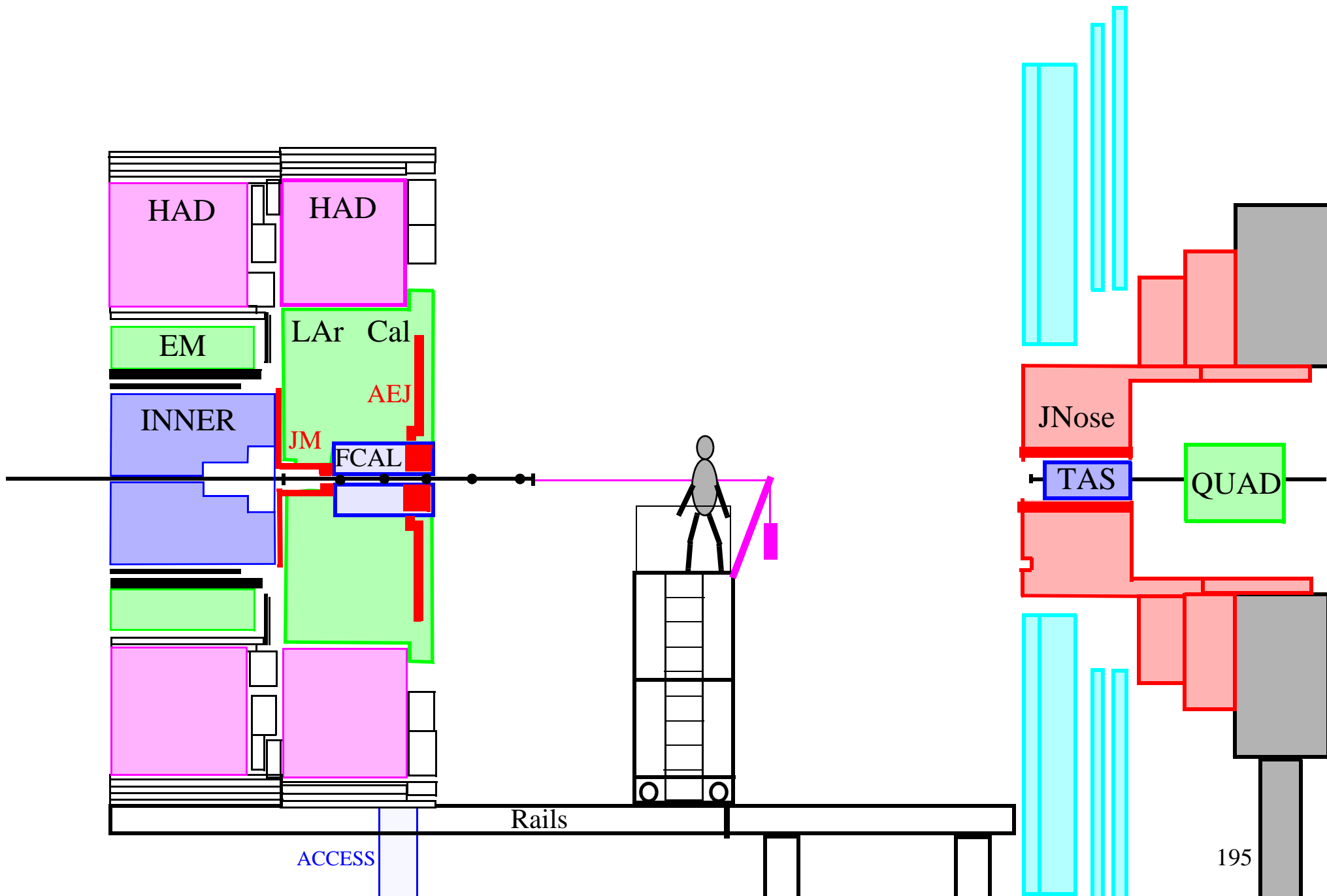

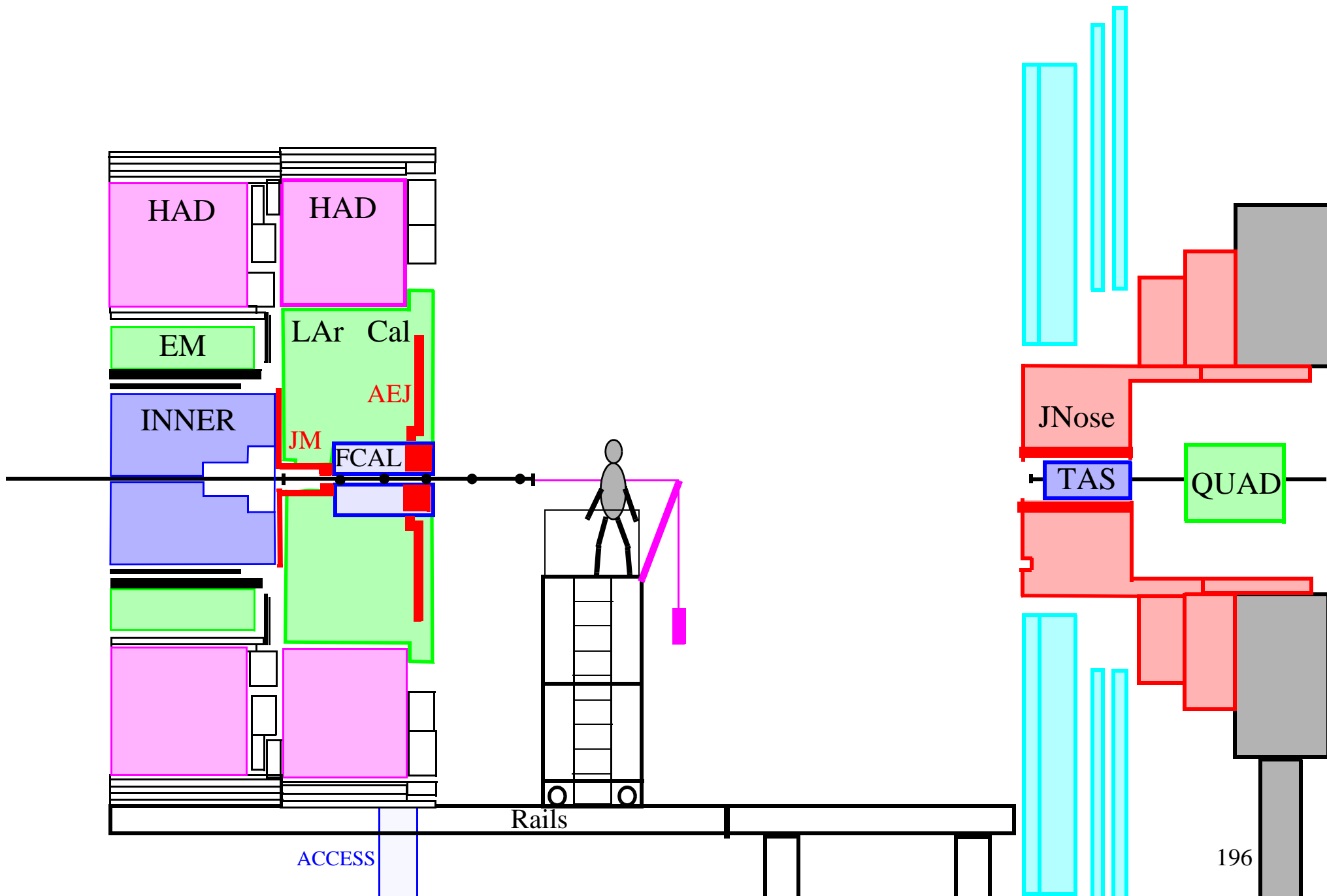

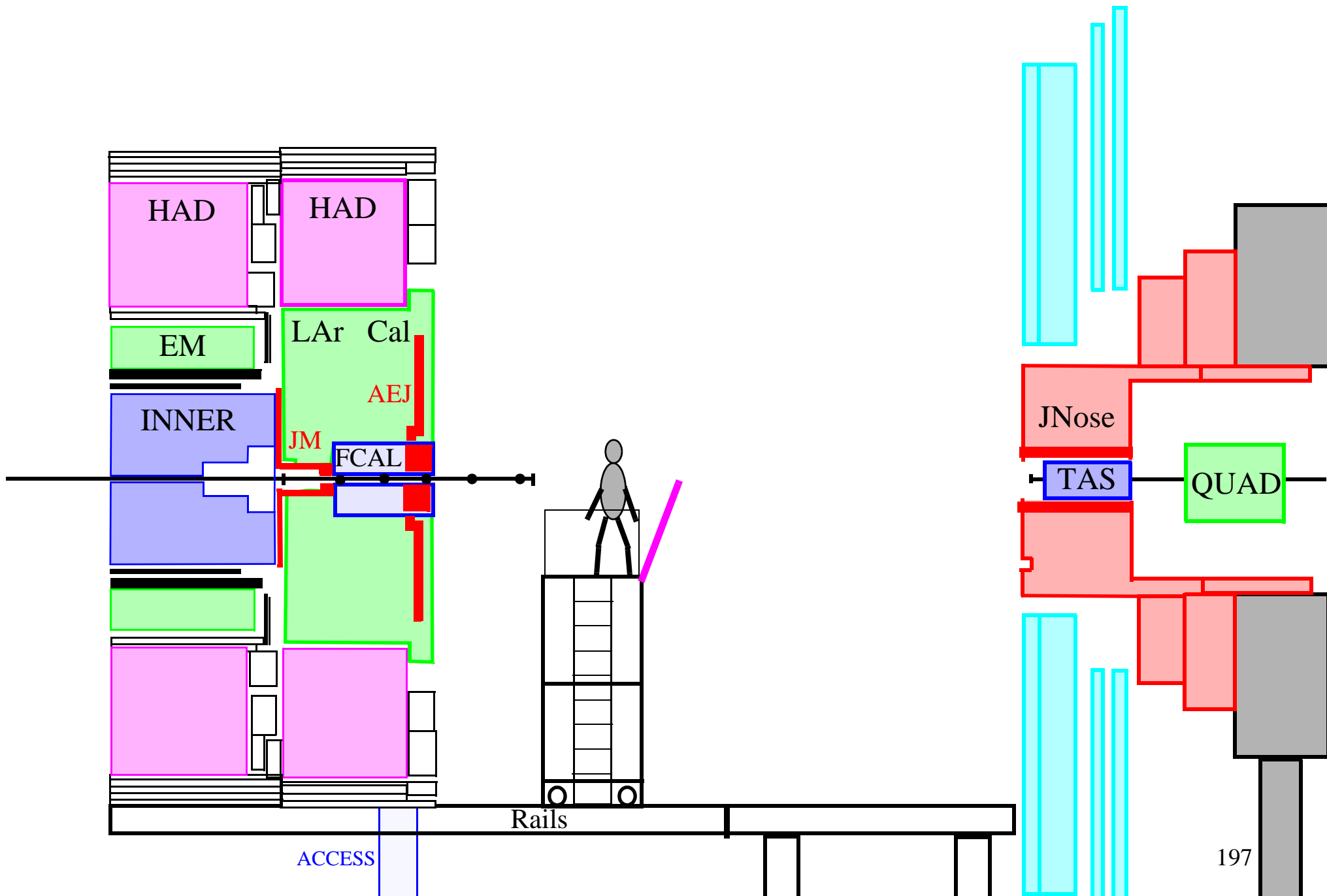

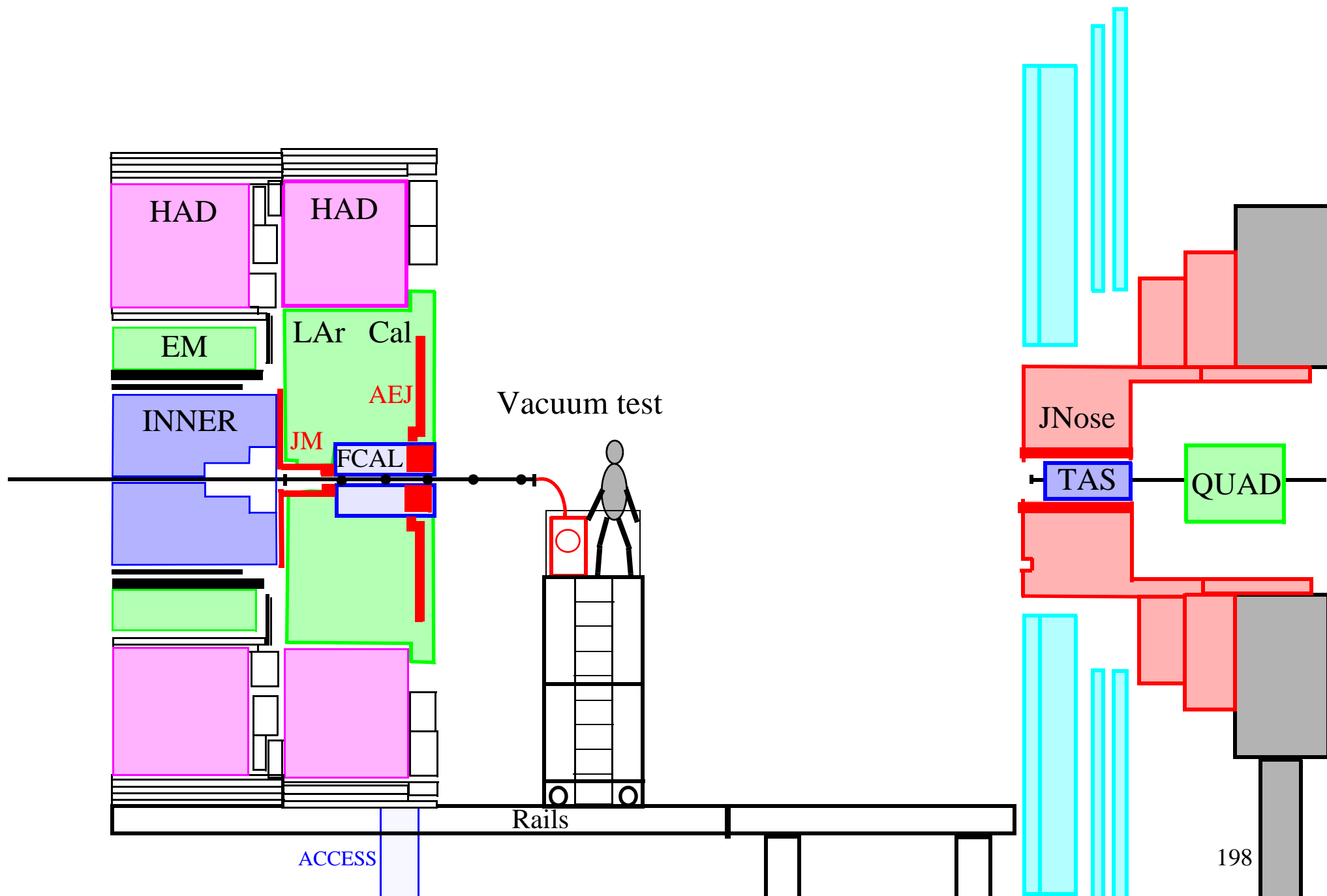

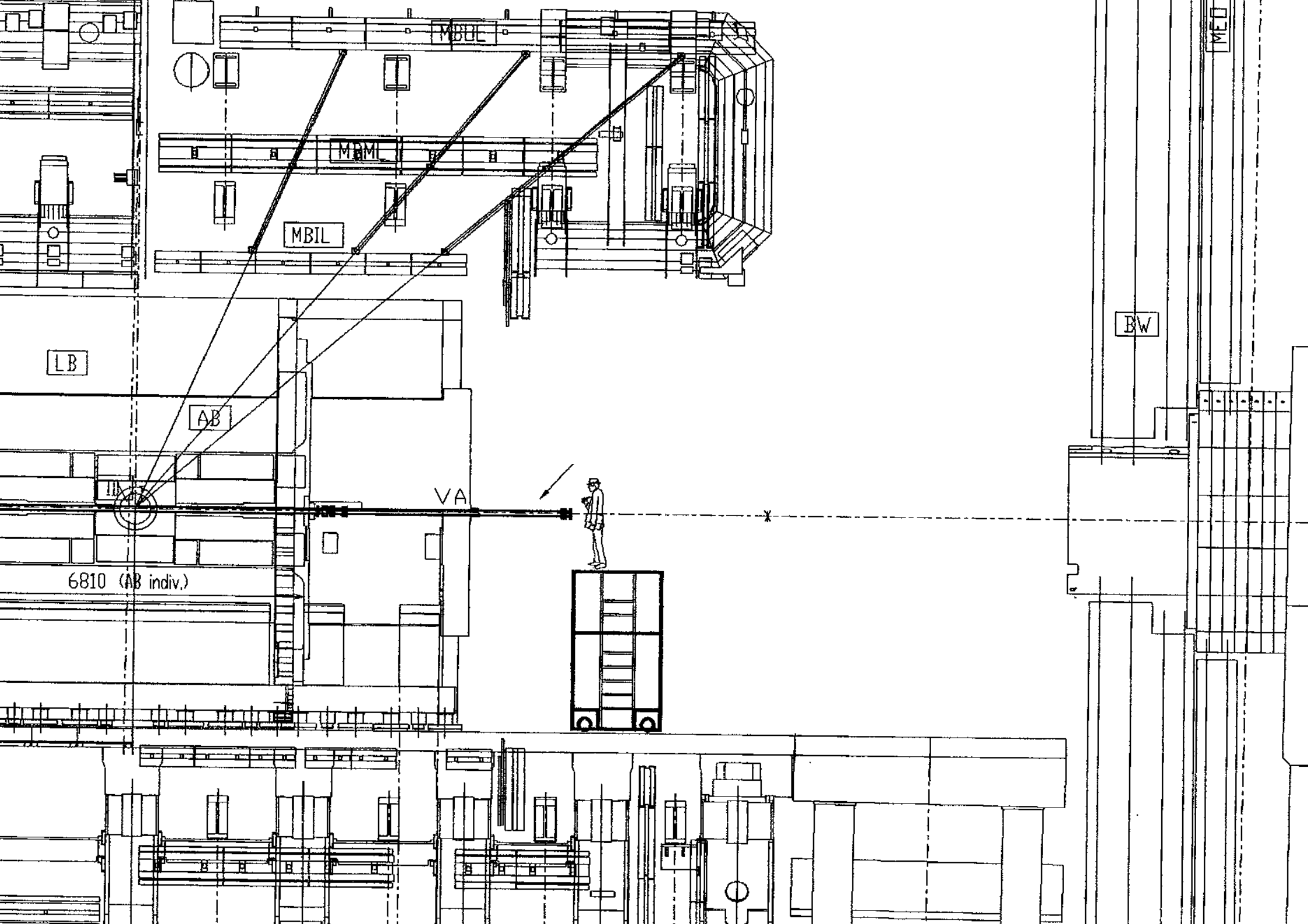

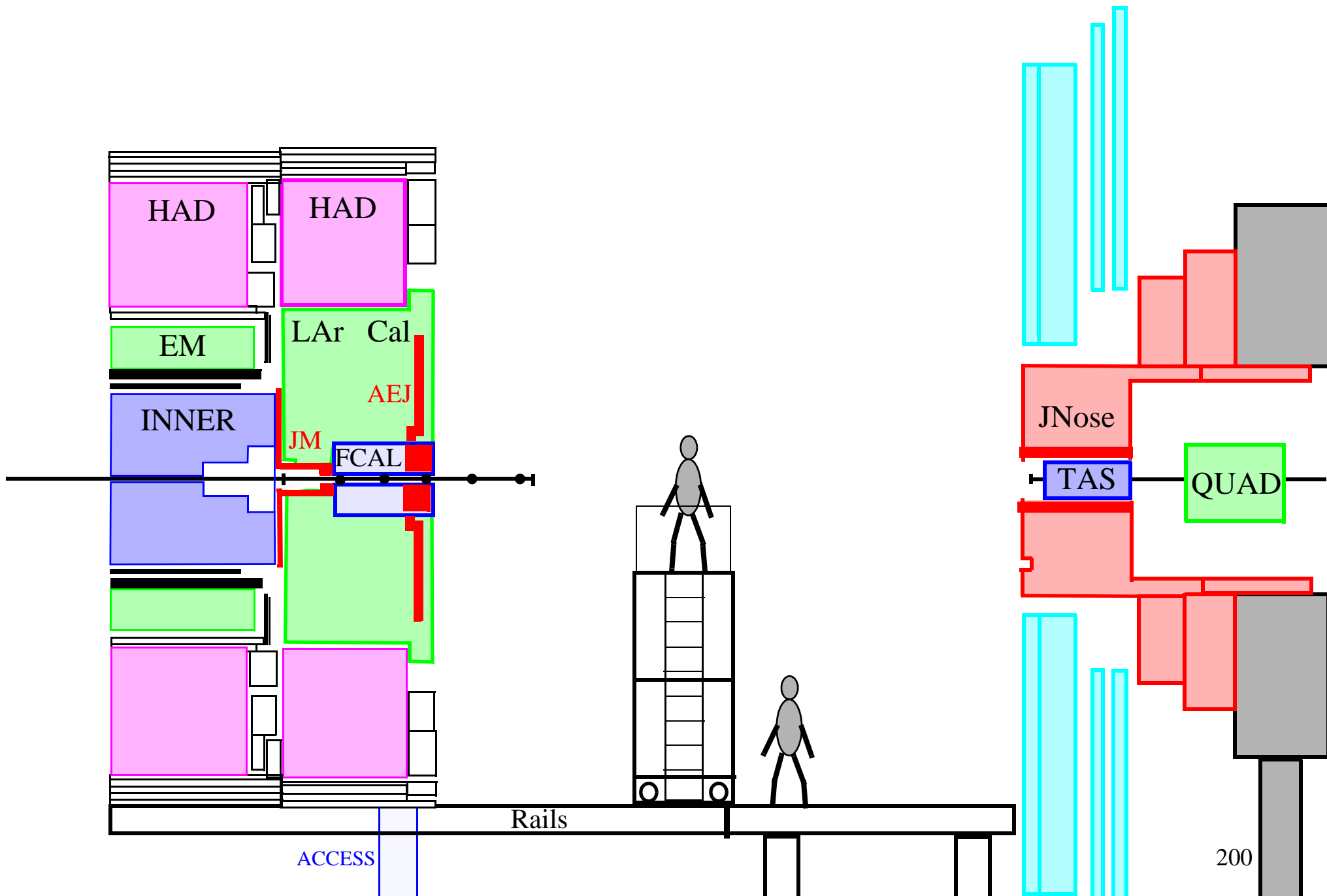

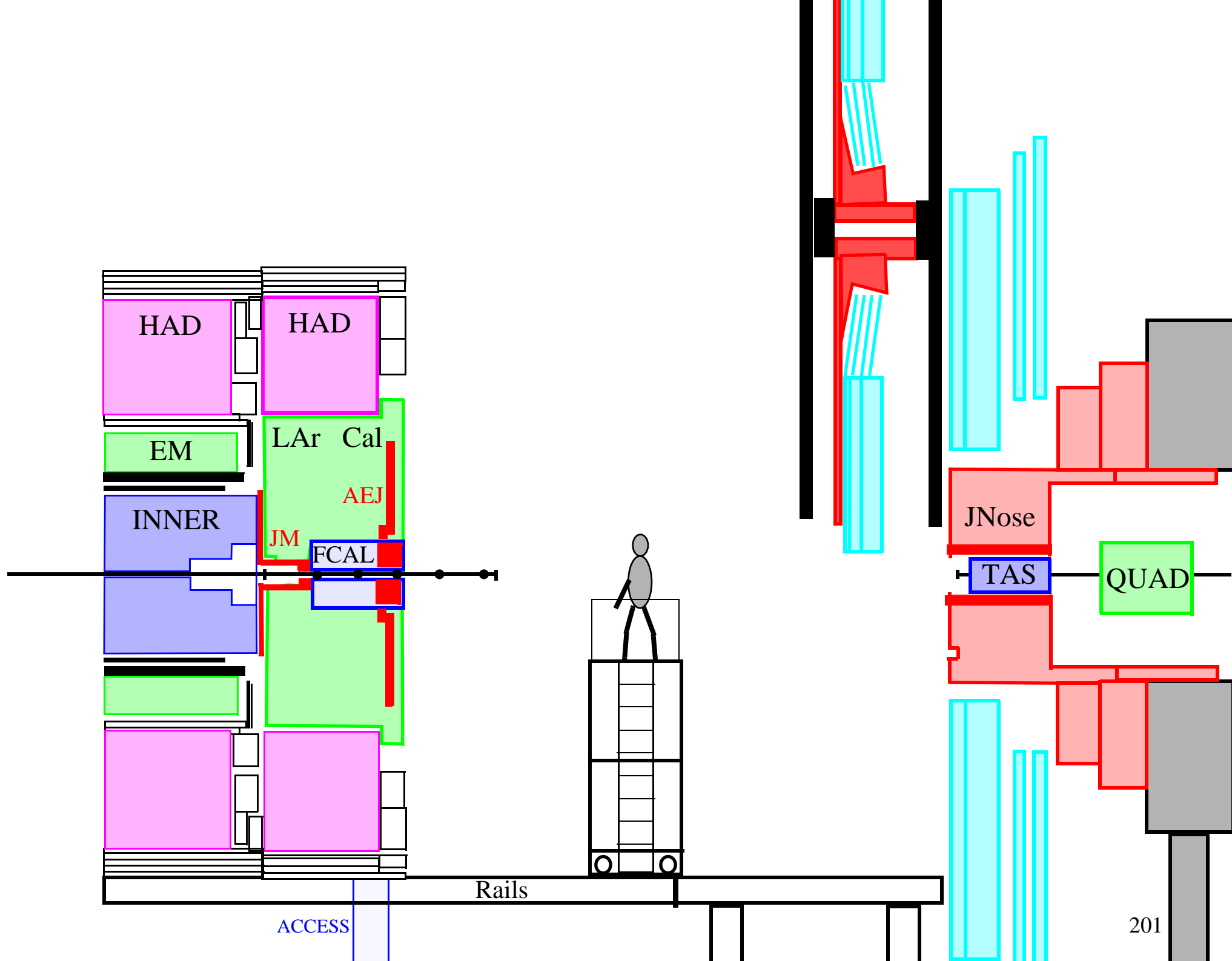

HAD

HAD

EM

LAr Cal

INNER

AEJ

JM

FCAL

JNose

TAS

QUAD

Rails

ACCESS

201

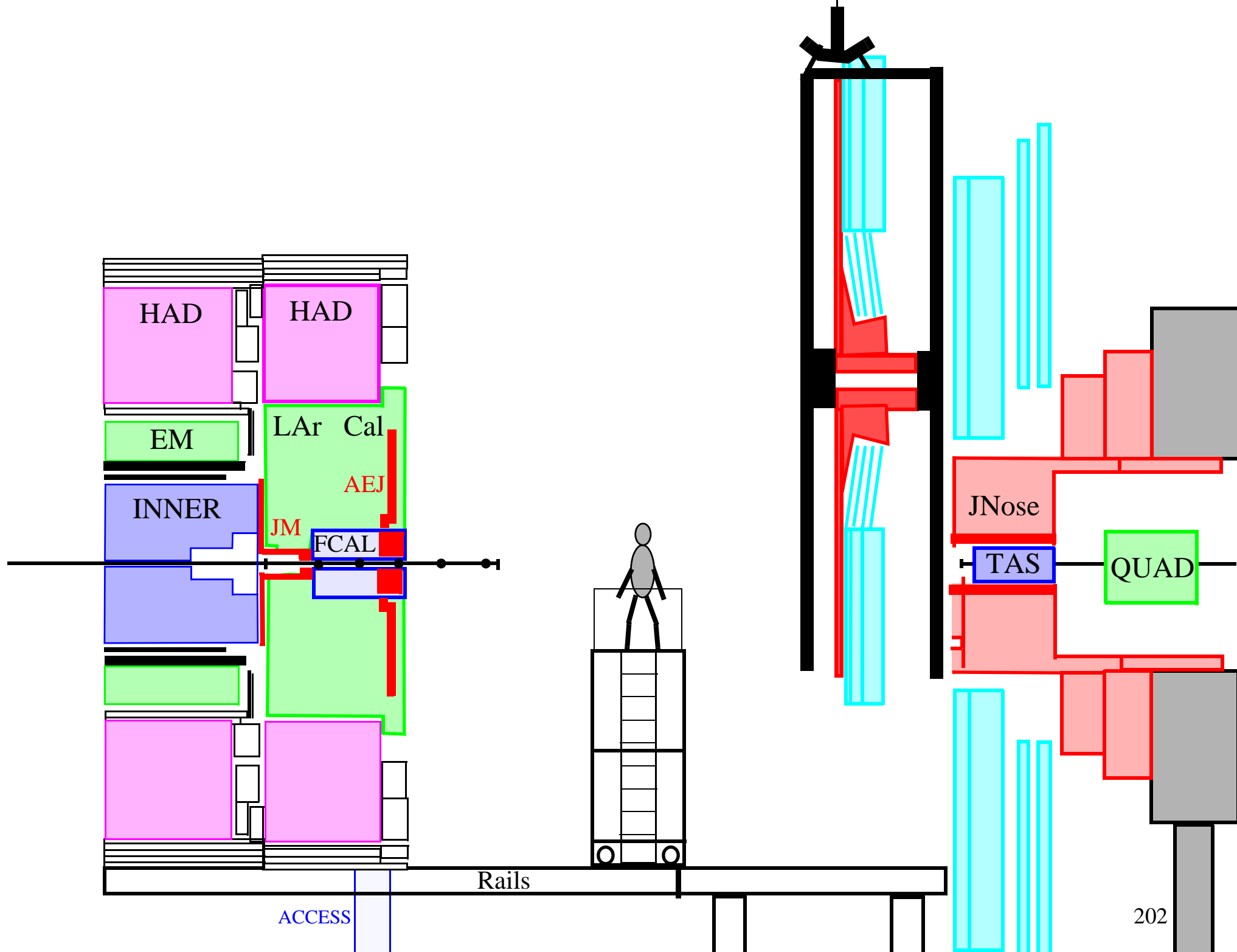

The JD/SW has to be moved in sideways to get under the ECT services.

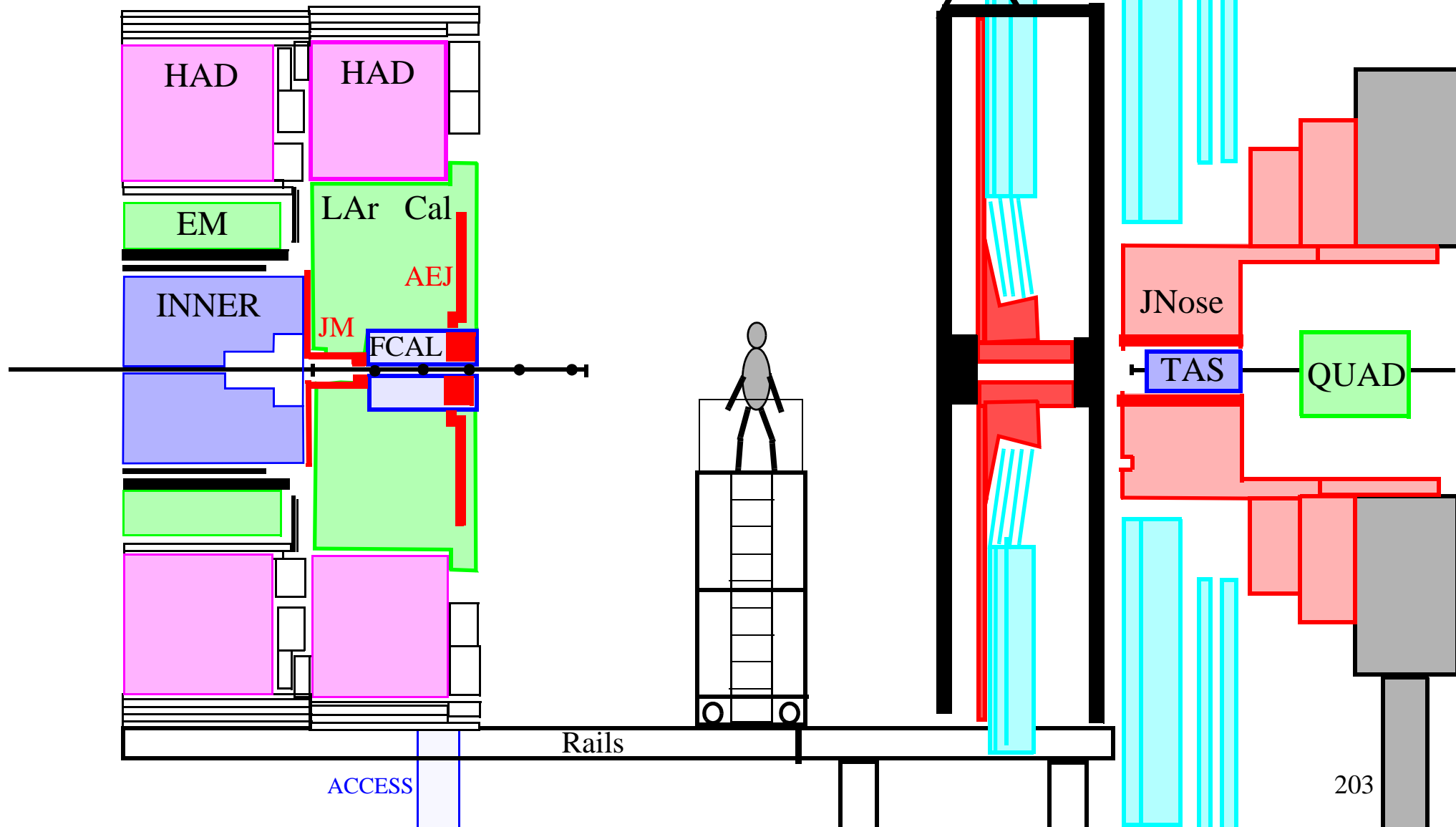

20 T THEORETICAL ZONE

20 T SAFETY ZONE

20 F EXTENDED ZONE

ECT

Liftingpoints

JD

JN

15787

437

1475

1664

800

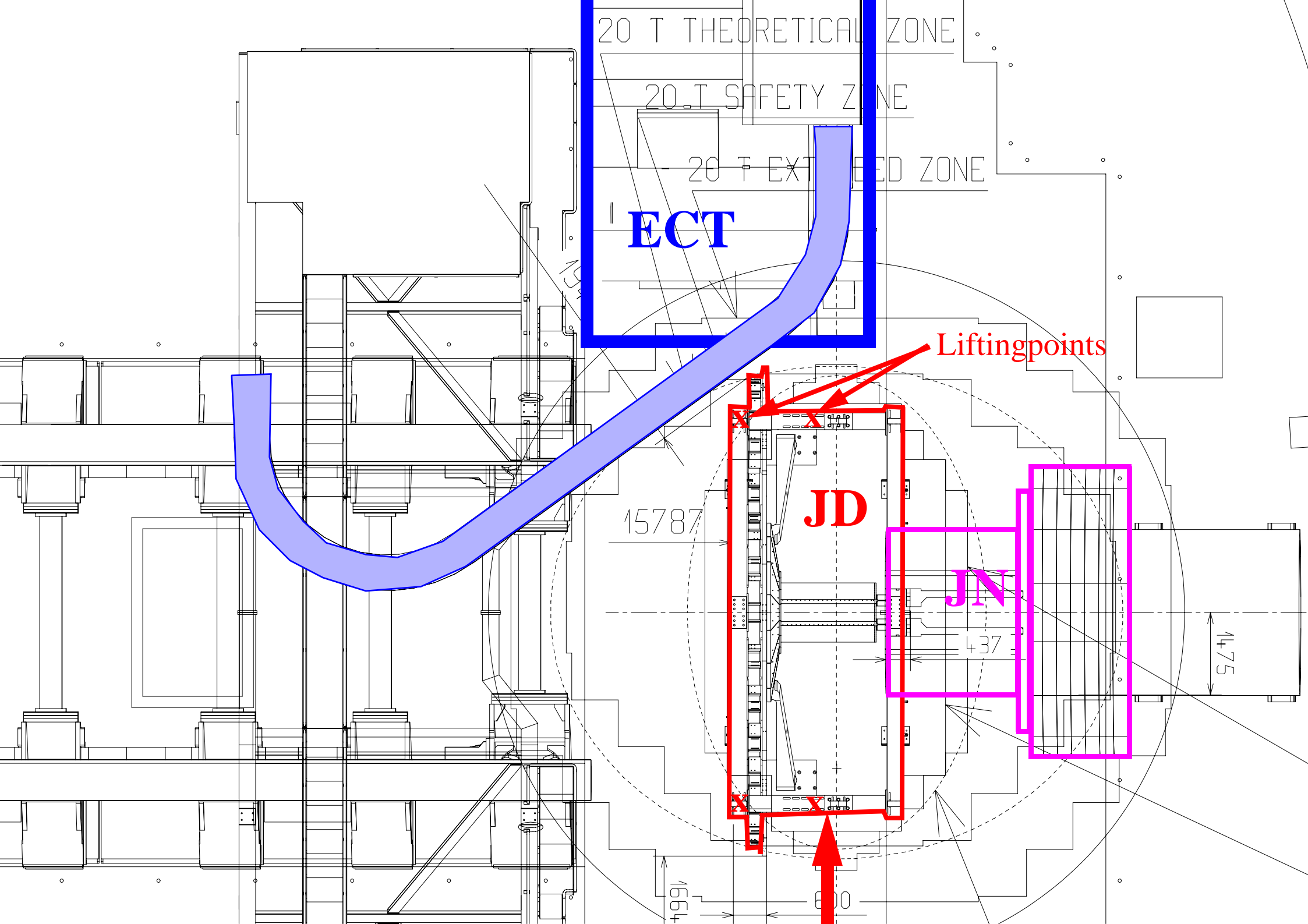

The JD/SW has to be moved towards the IP on its airpads.

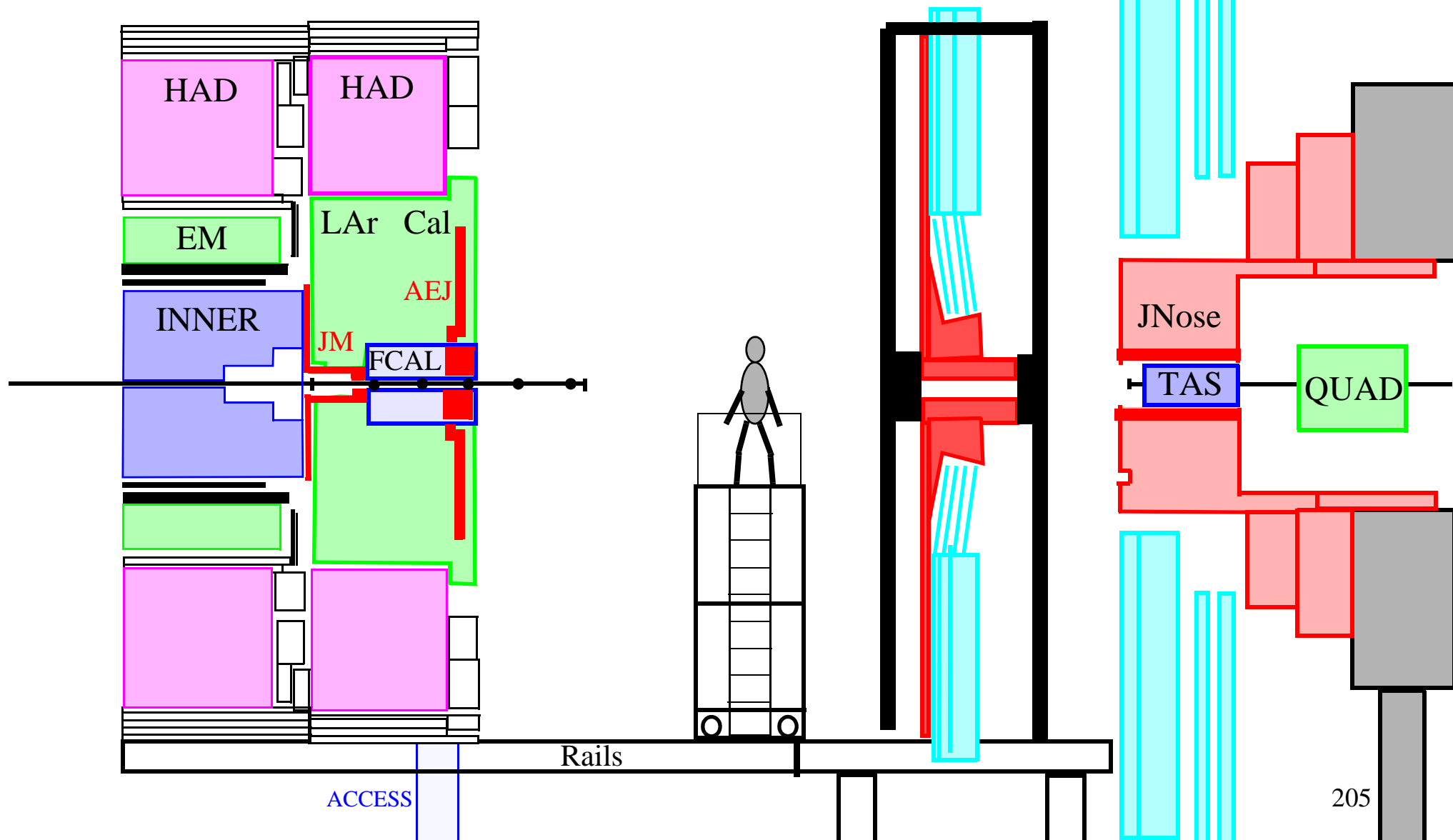

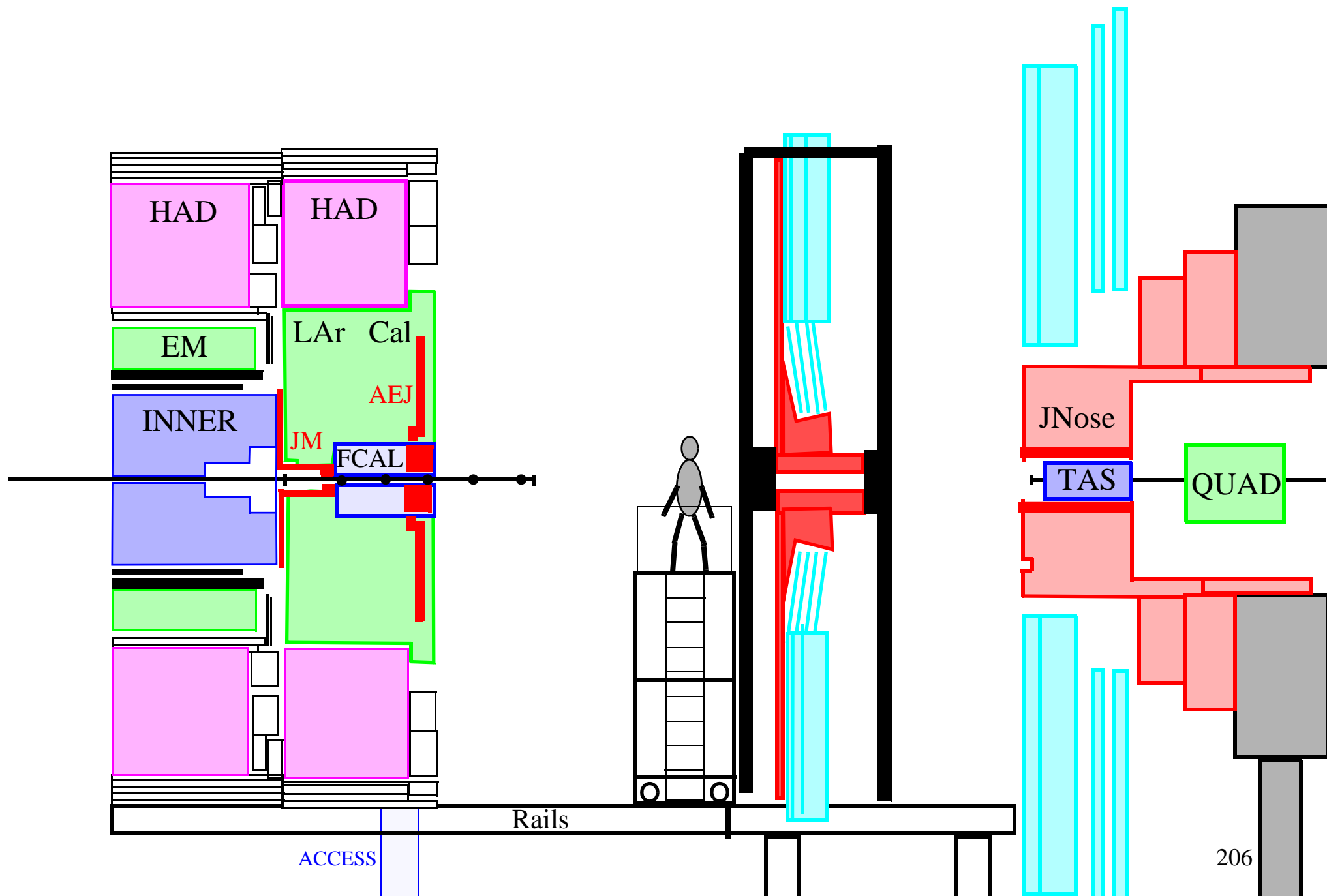

20 T THEORETICAL ZONE

20 T SAFETY ZONE

20 F EXTENDED ZONE

ECT

JD

15787

JN

437

1475

1564

600

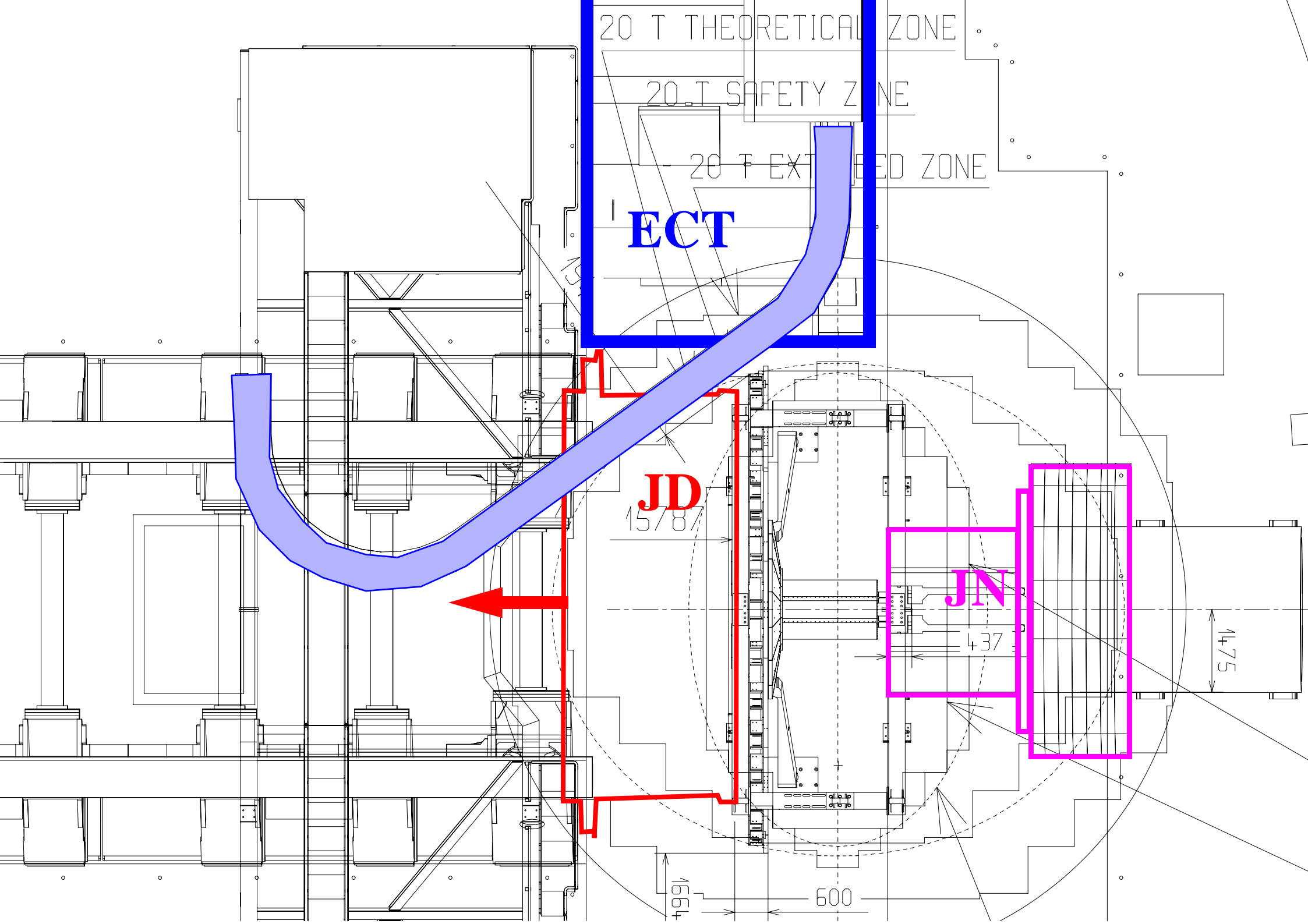

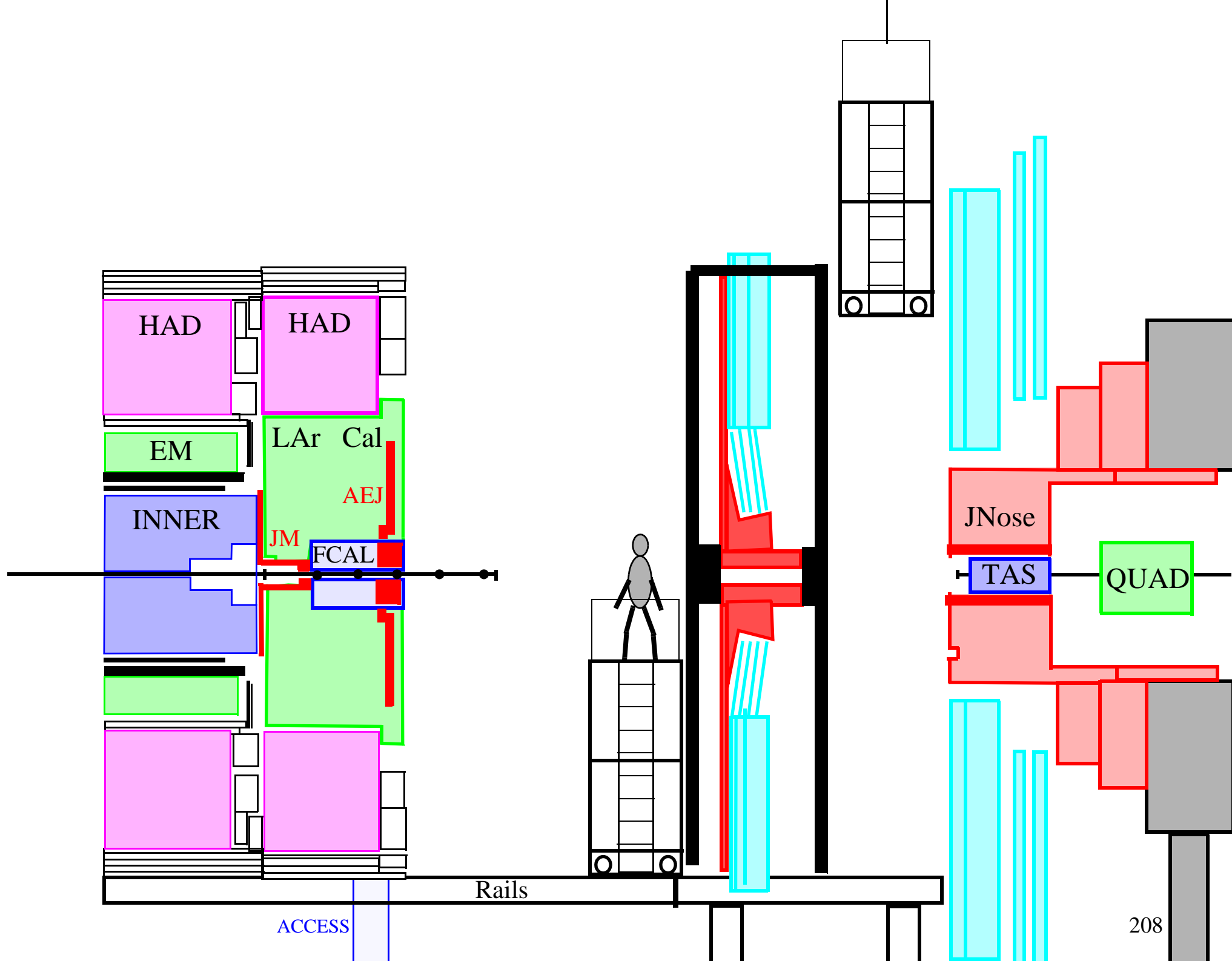

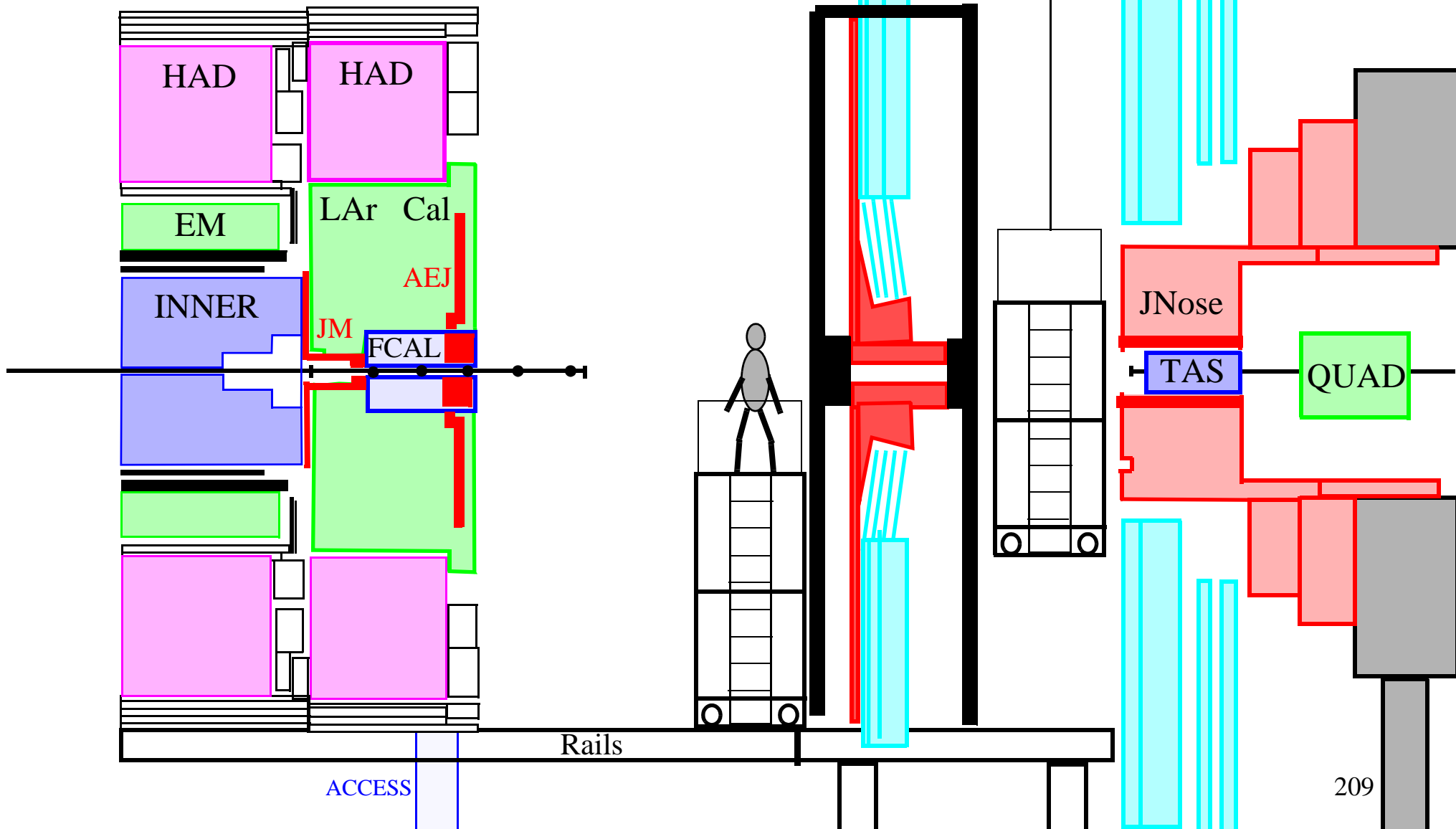

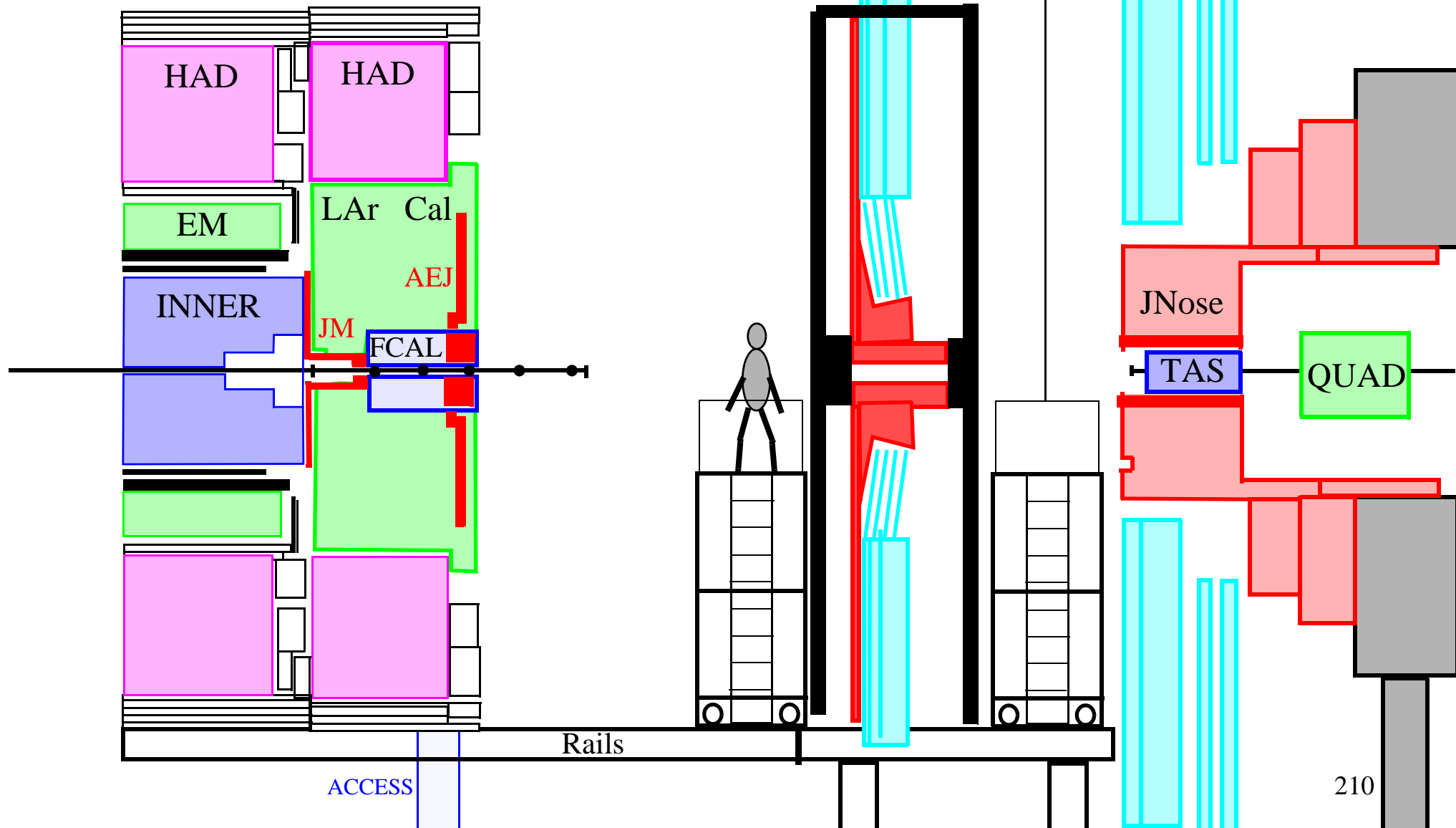

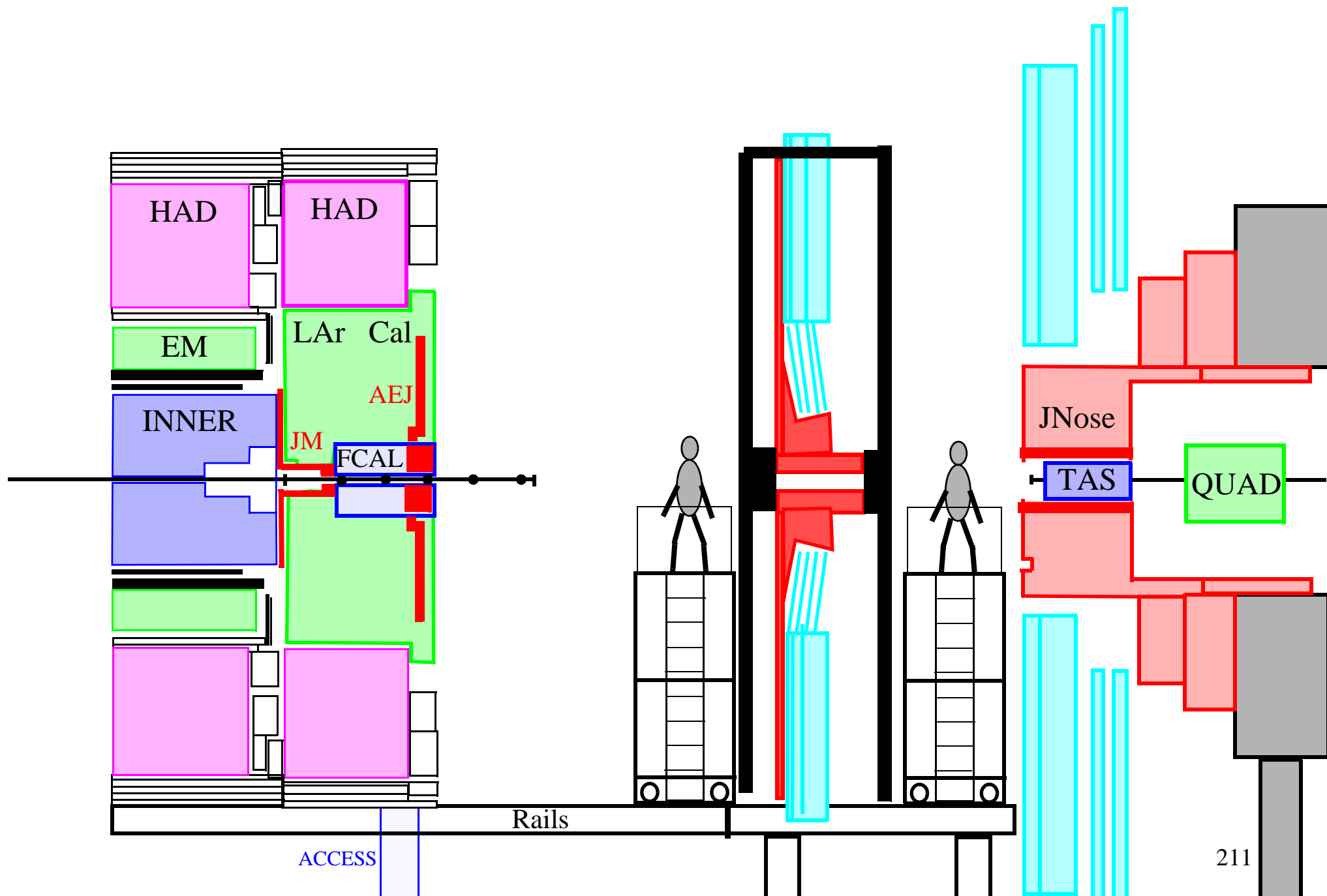

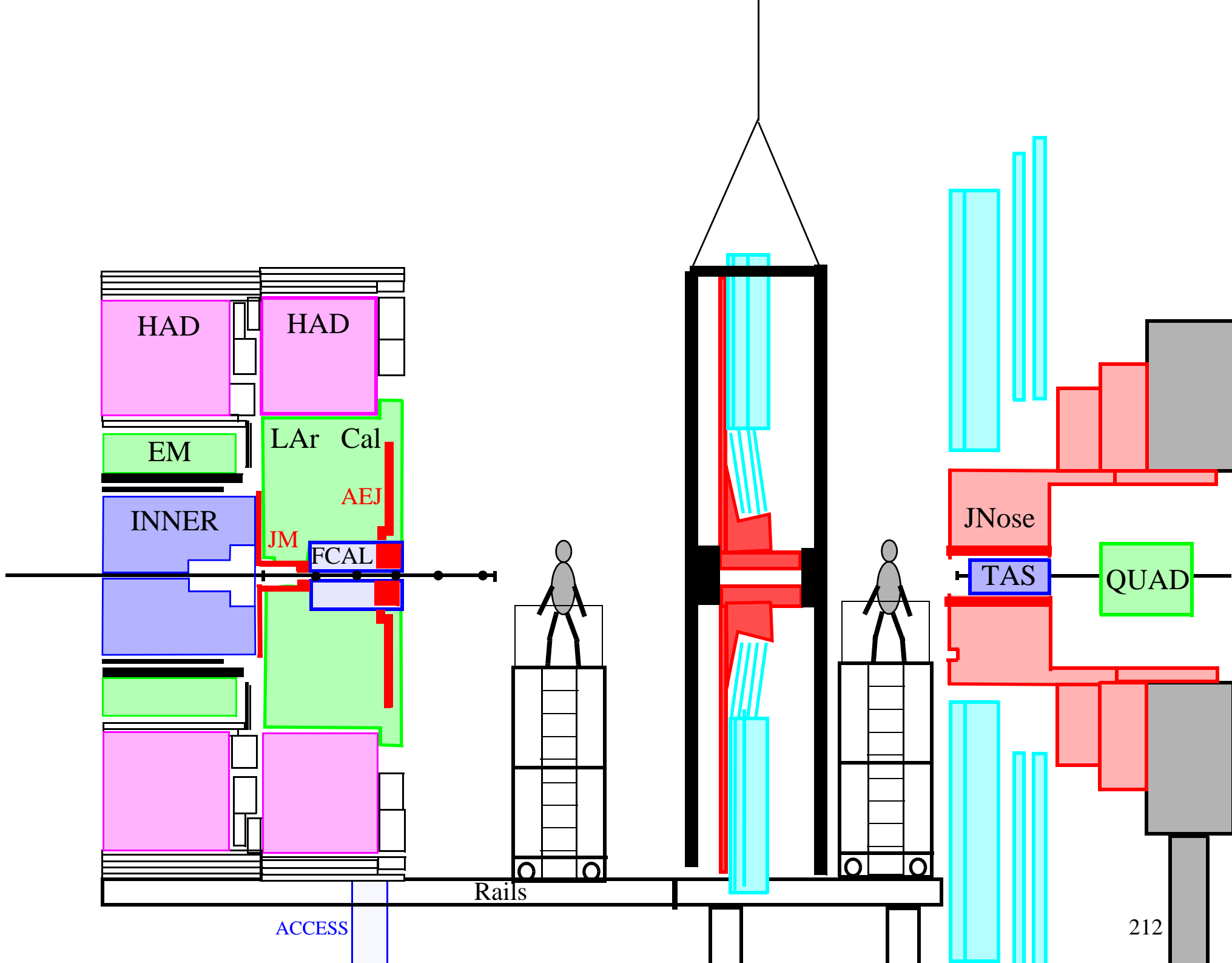

20 T THEORETICAL ZONE

20 T SAFETY ZONE

20 F EXTENDED ZONE

ECT

New
Liftingpoints

JD

JN

15787

437

1475

1564

600

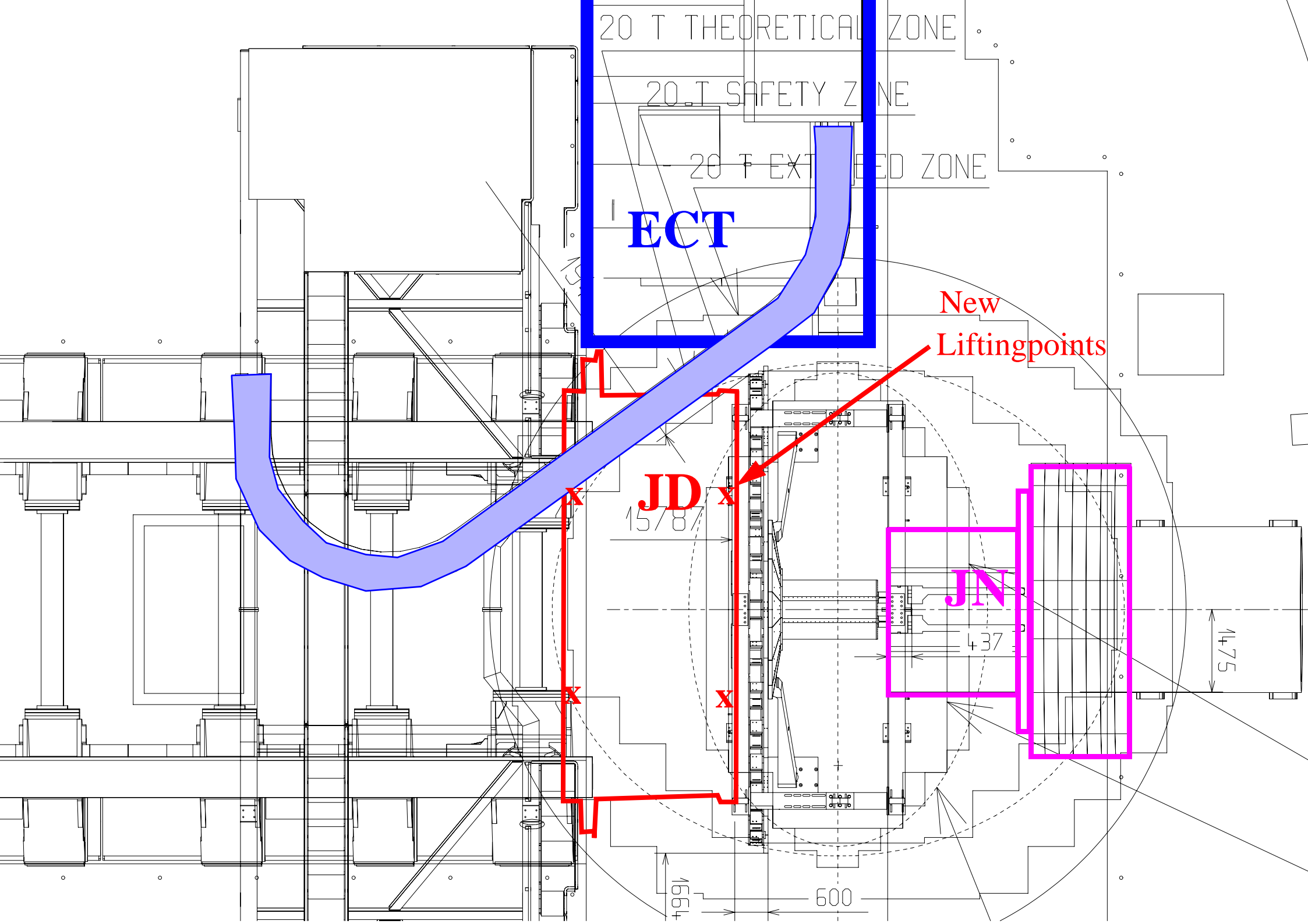

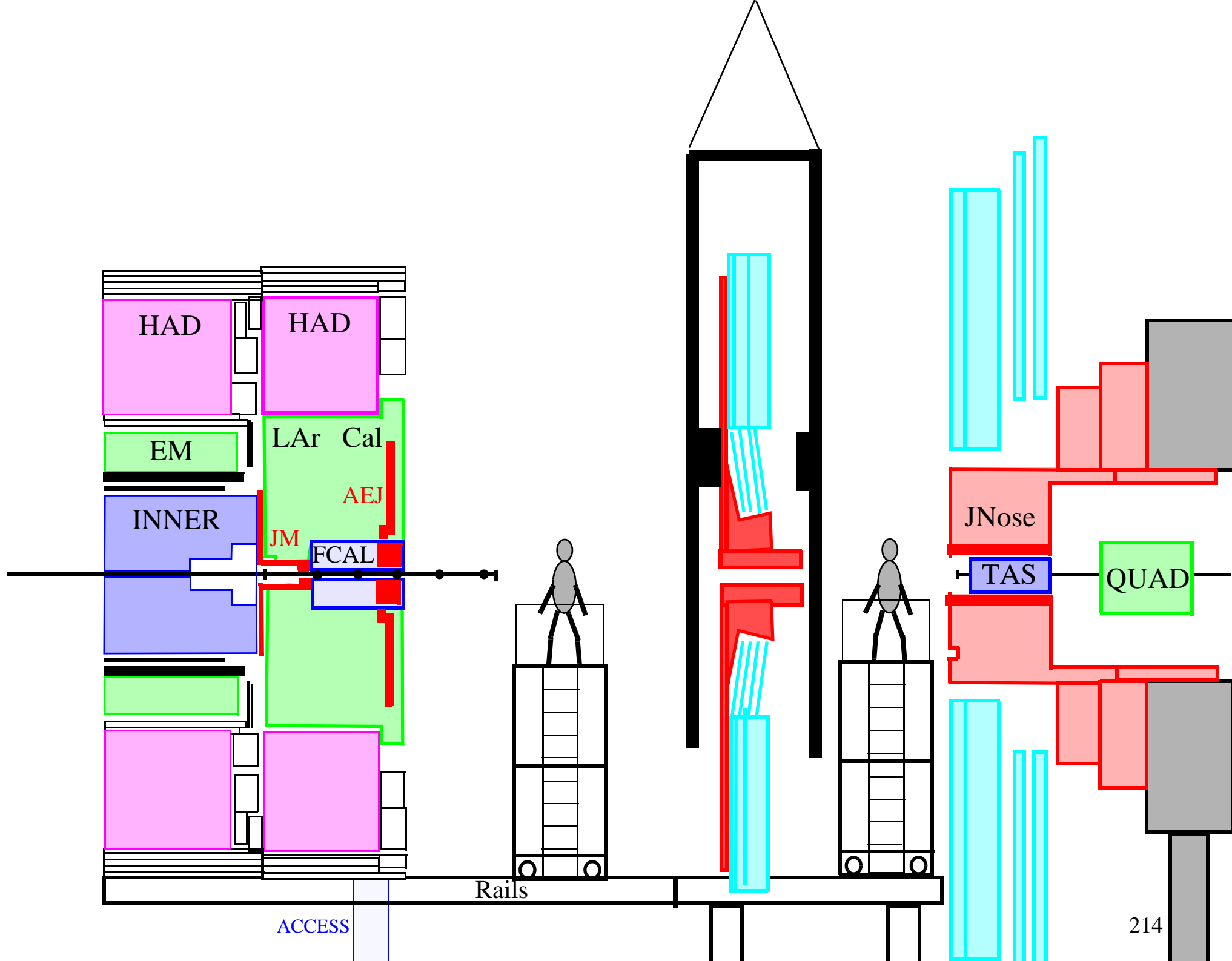

ACCESS

Rails

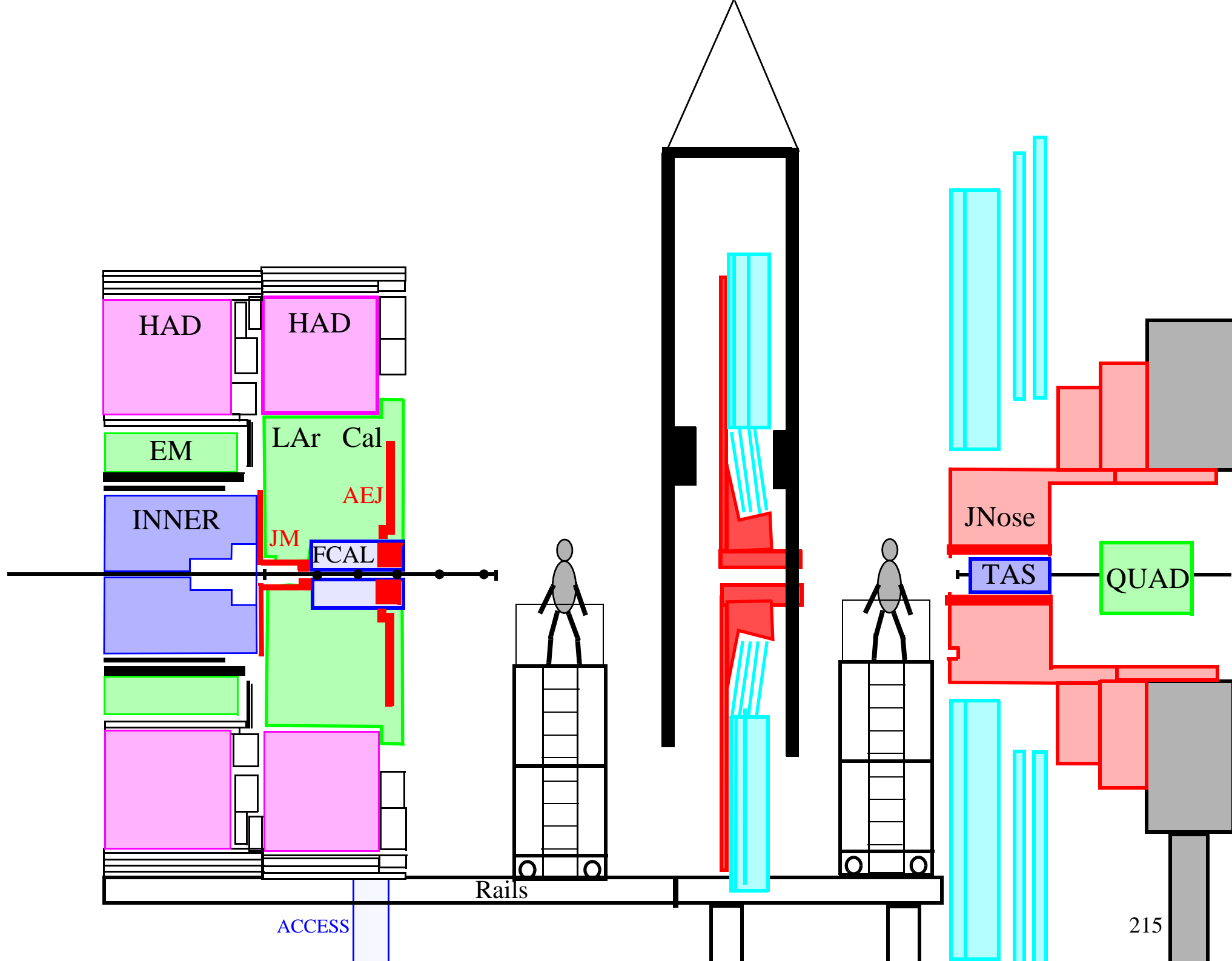

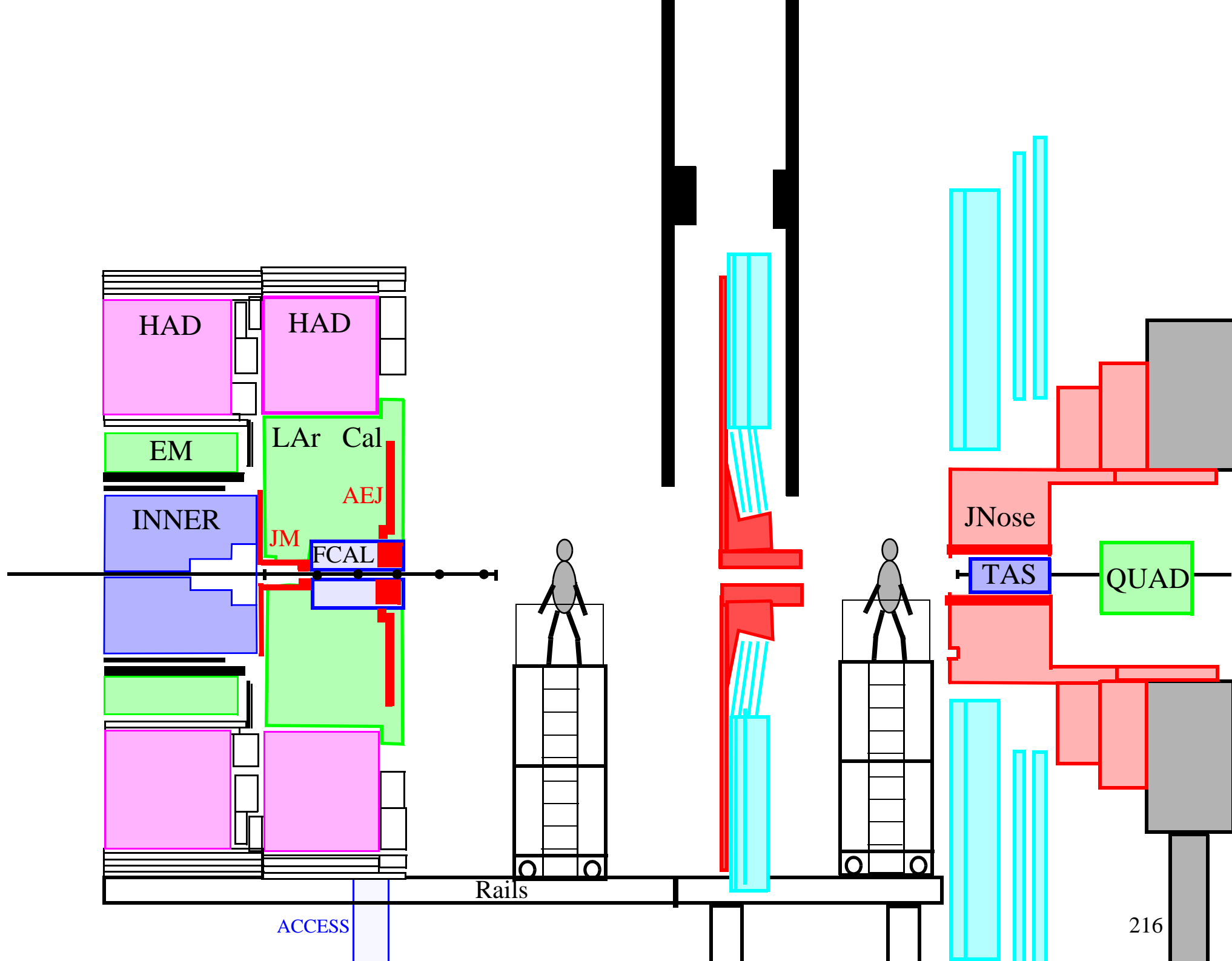

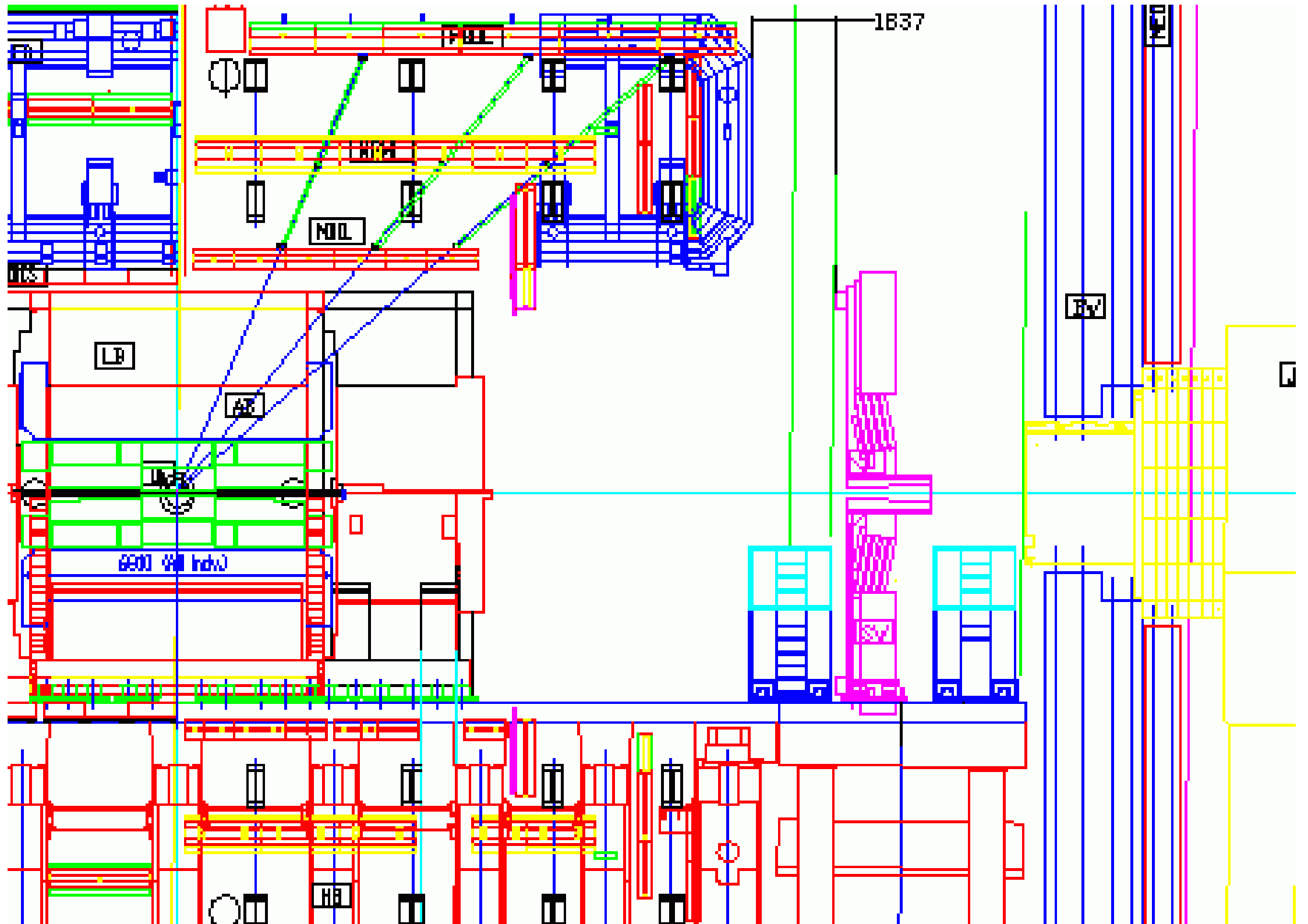

1837

HALL

HALL

LAB

LAB

LAB

6500 (All Ind.)

HALL

SW

MECH

LAB

SW

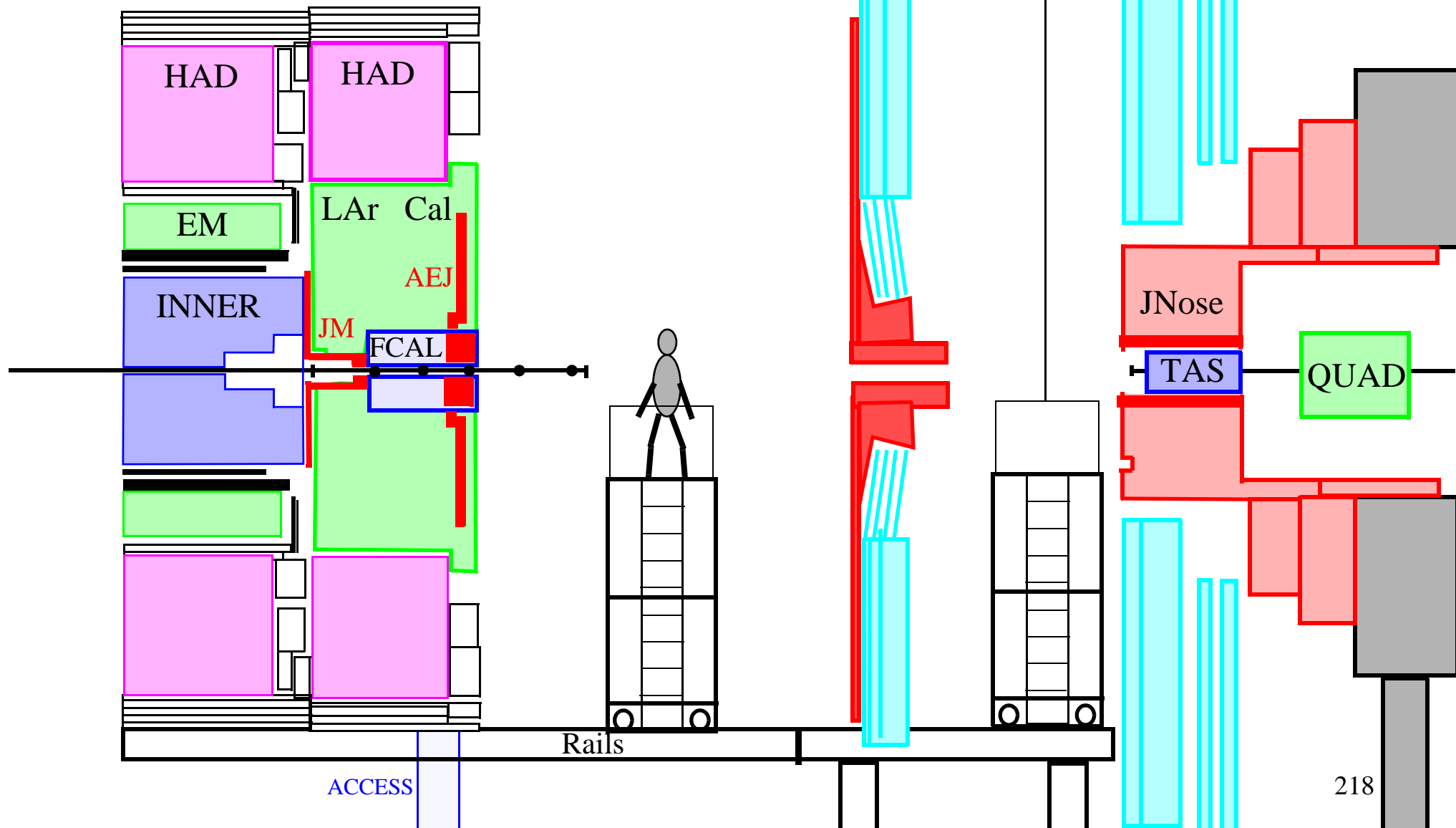

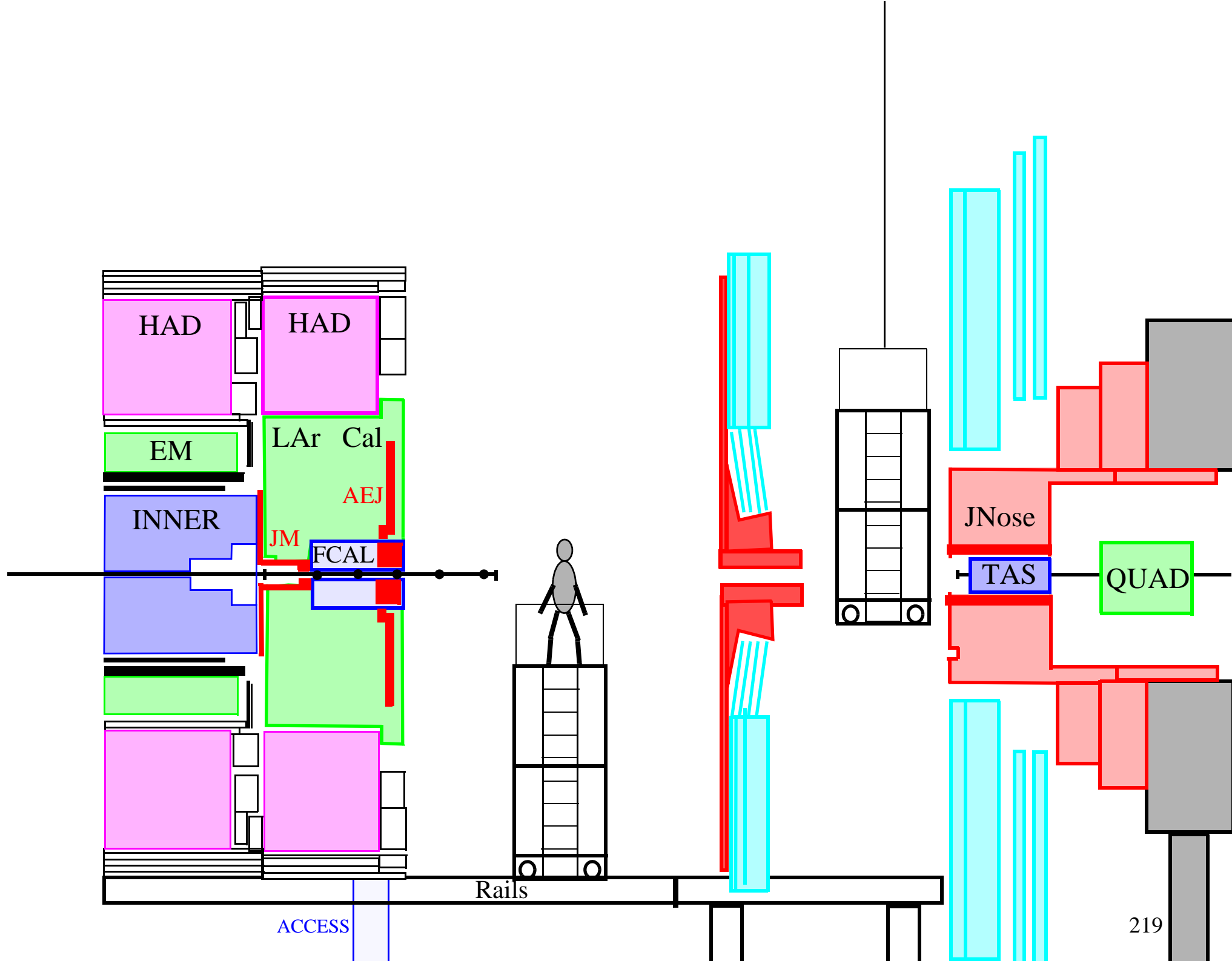

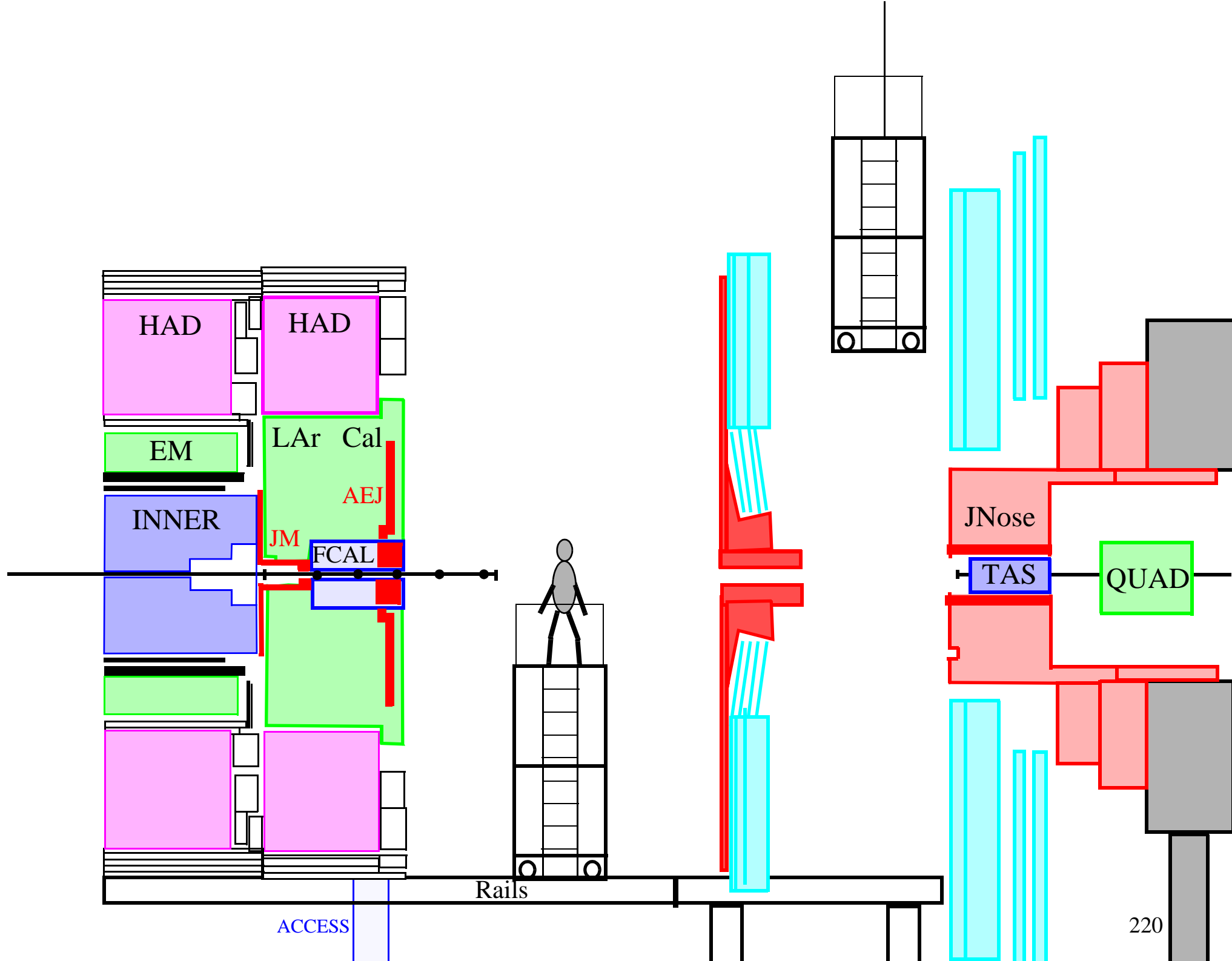

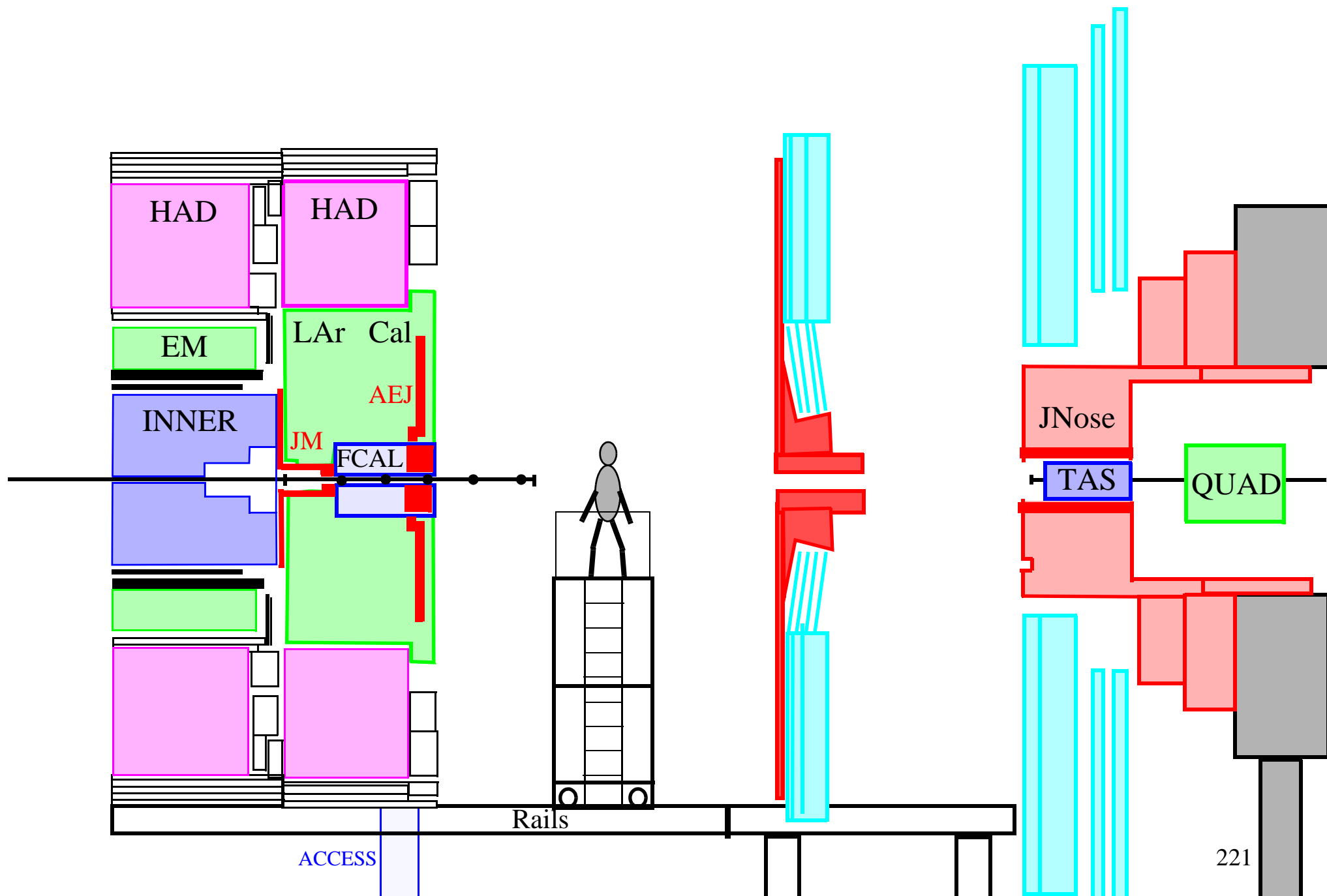

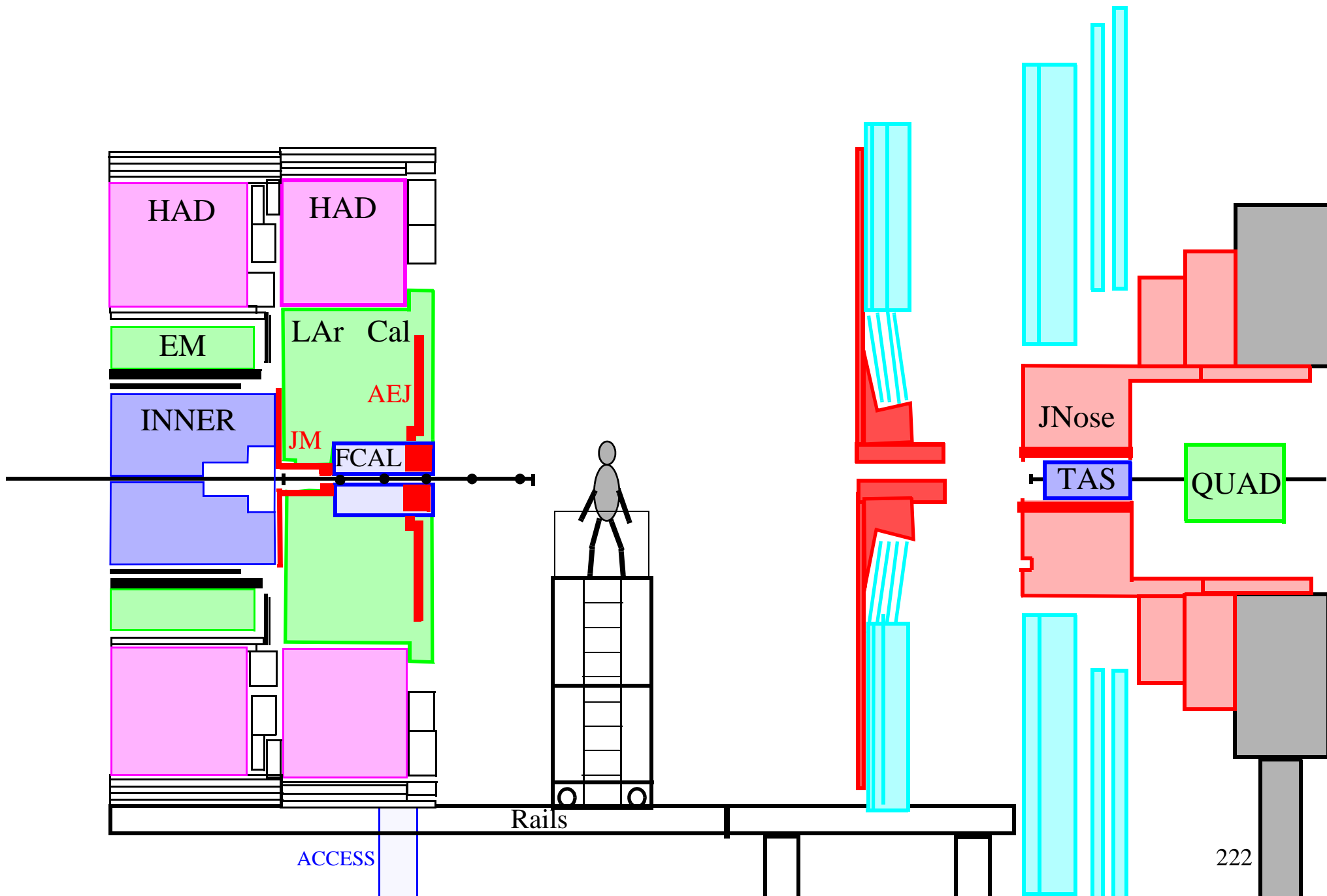

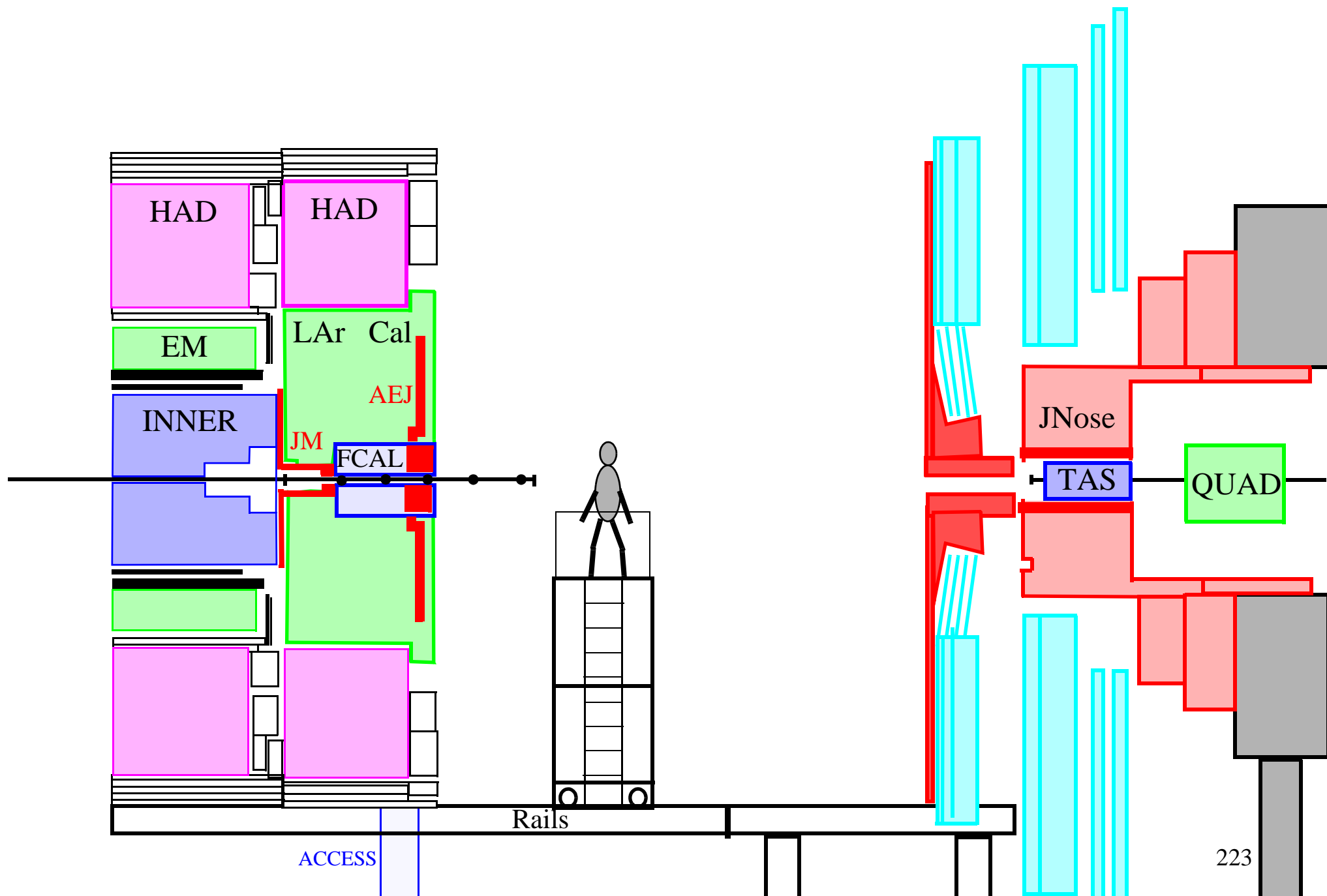

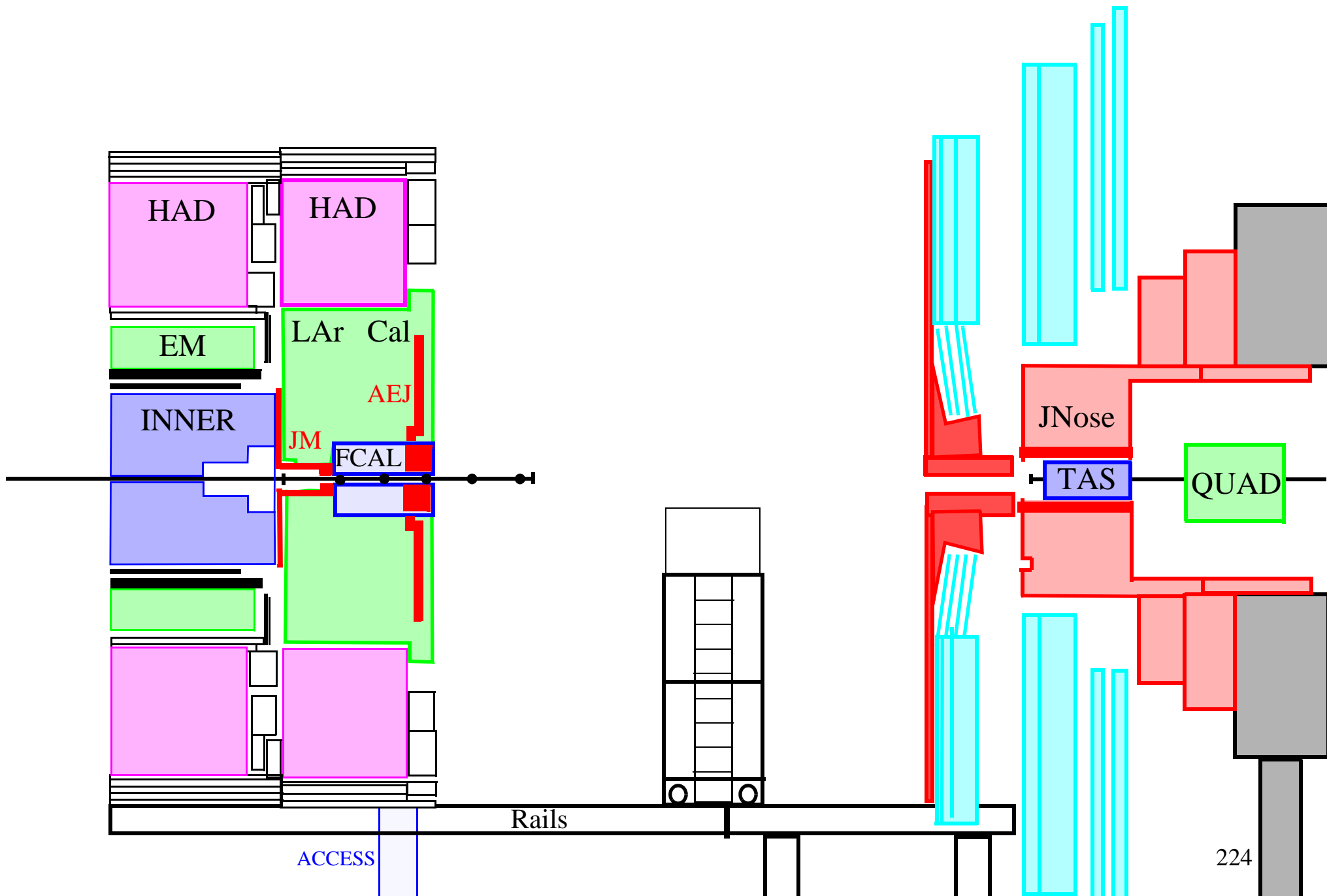

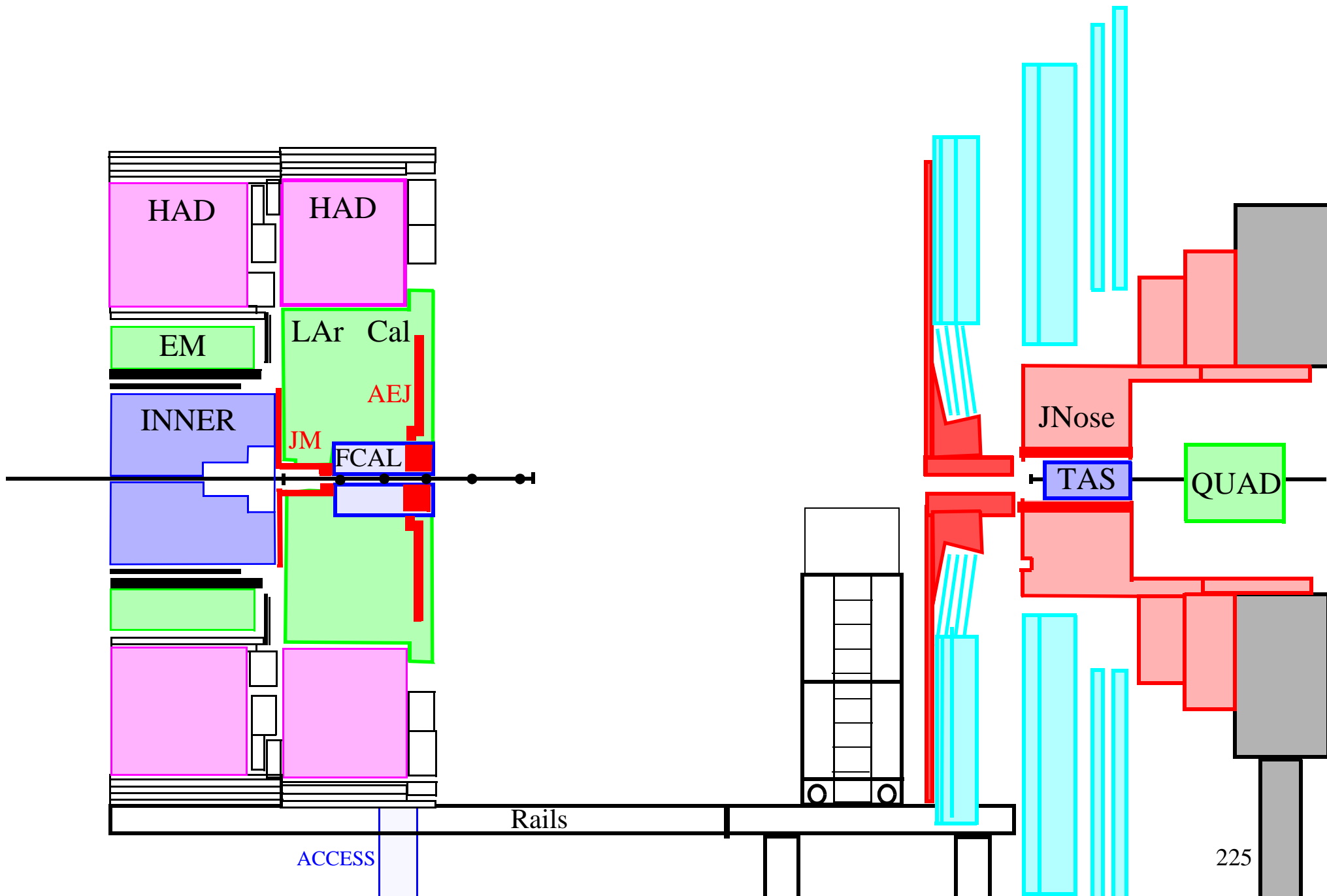

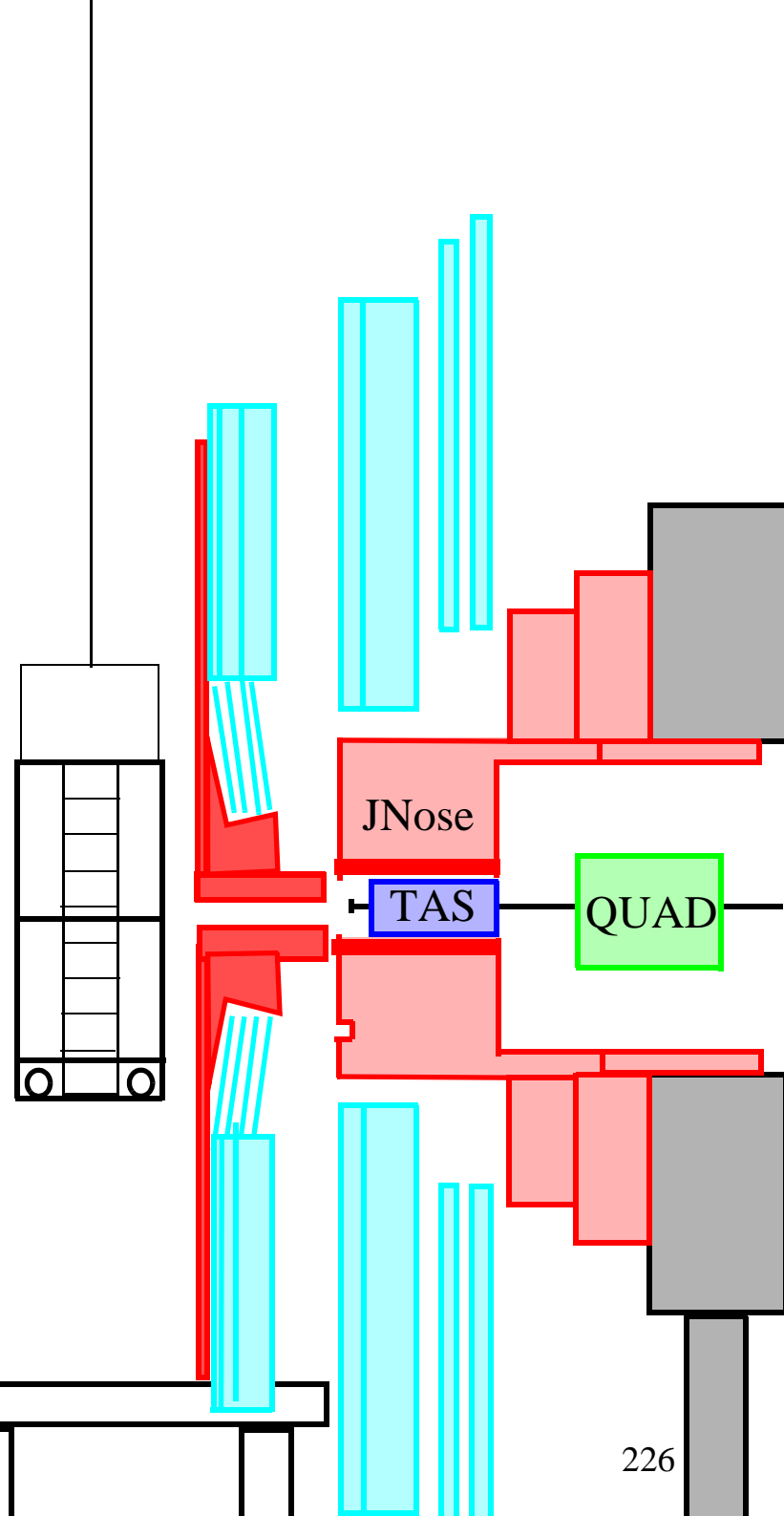
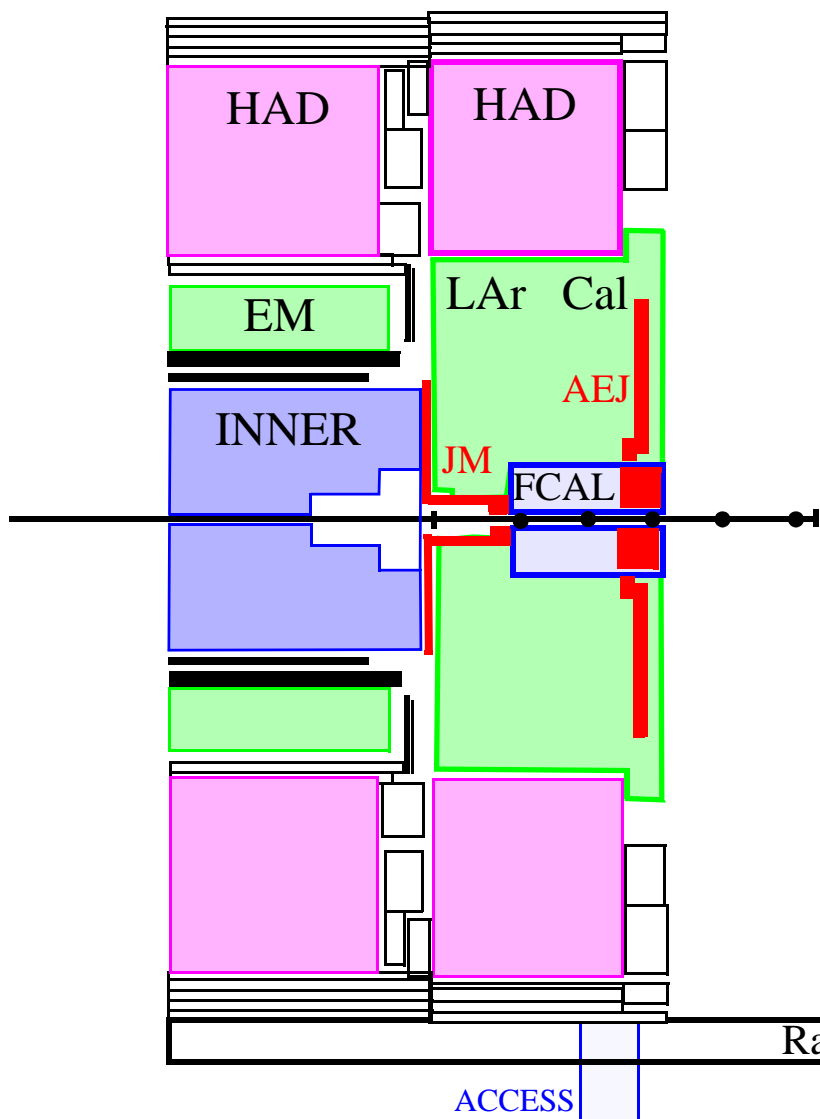

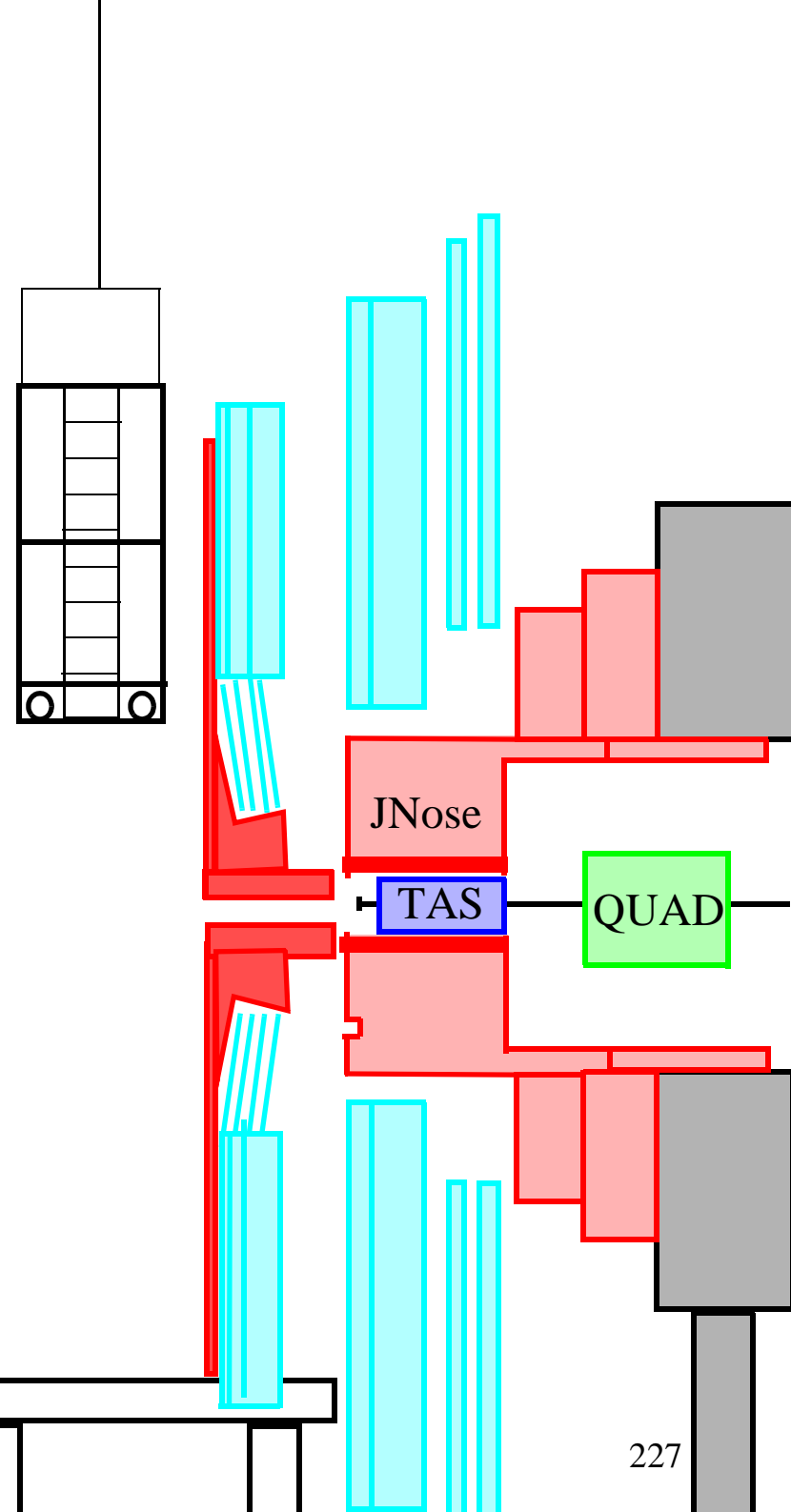
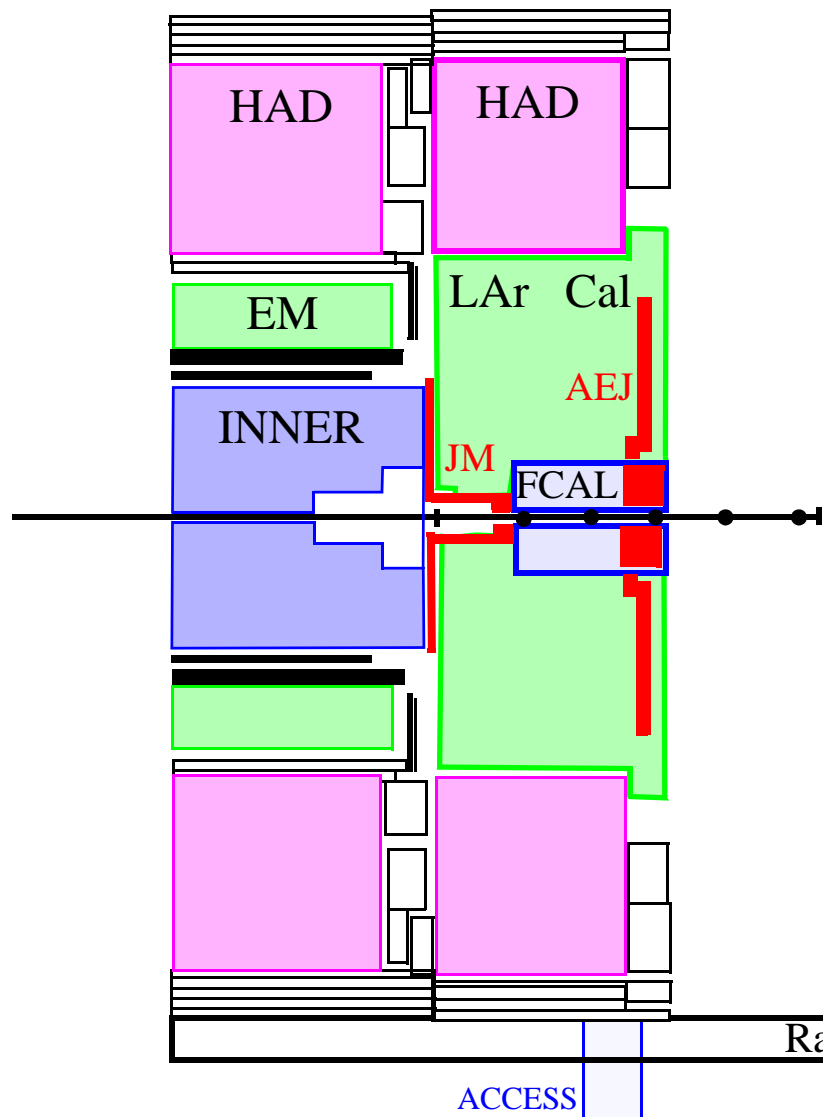

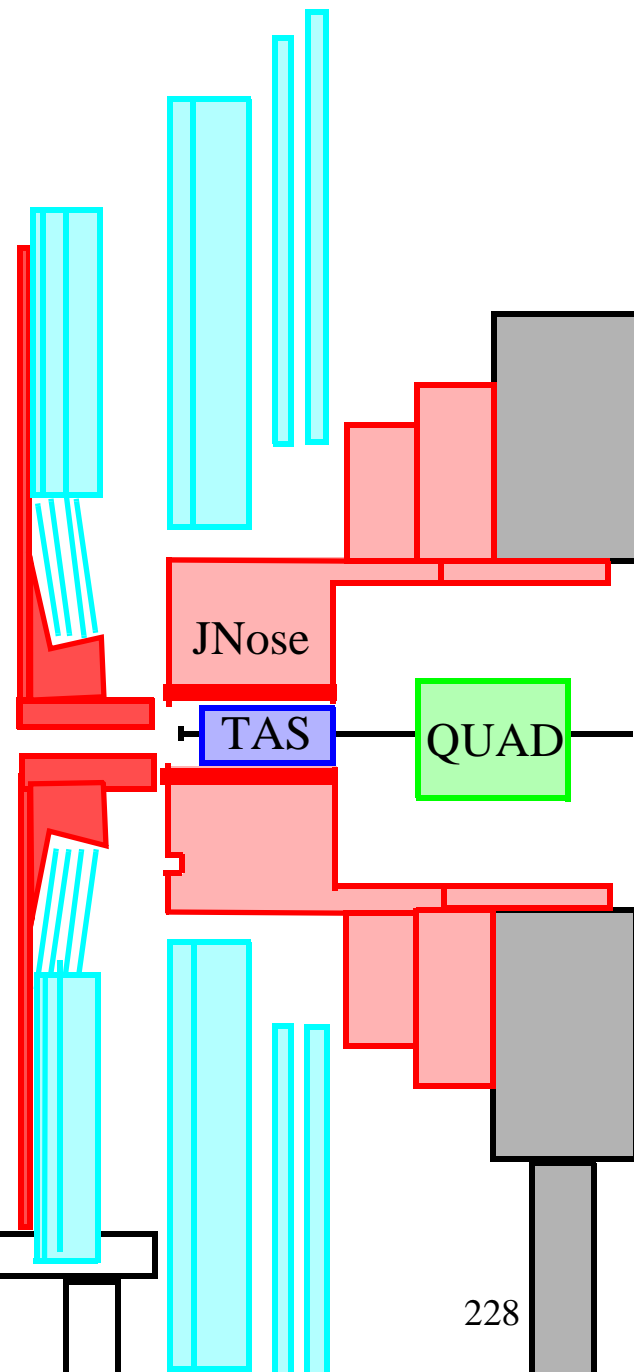
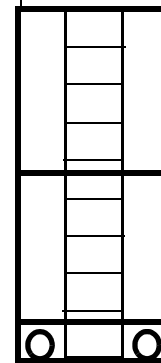
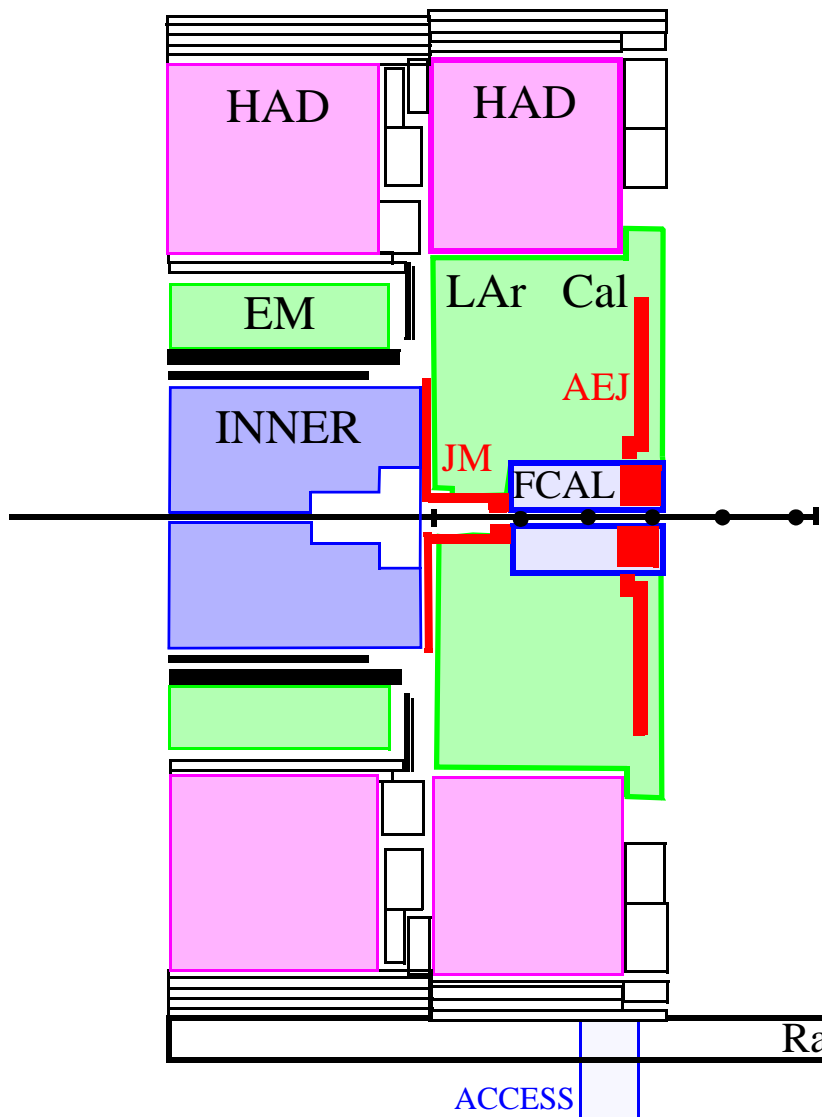

Rails

ACCESS

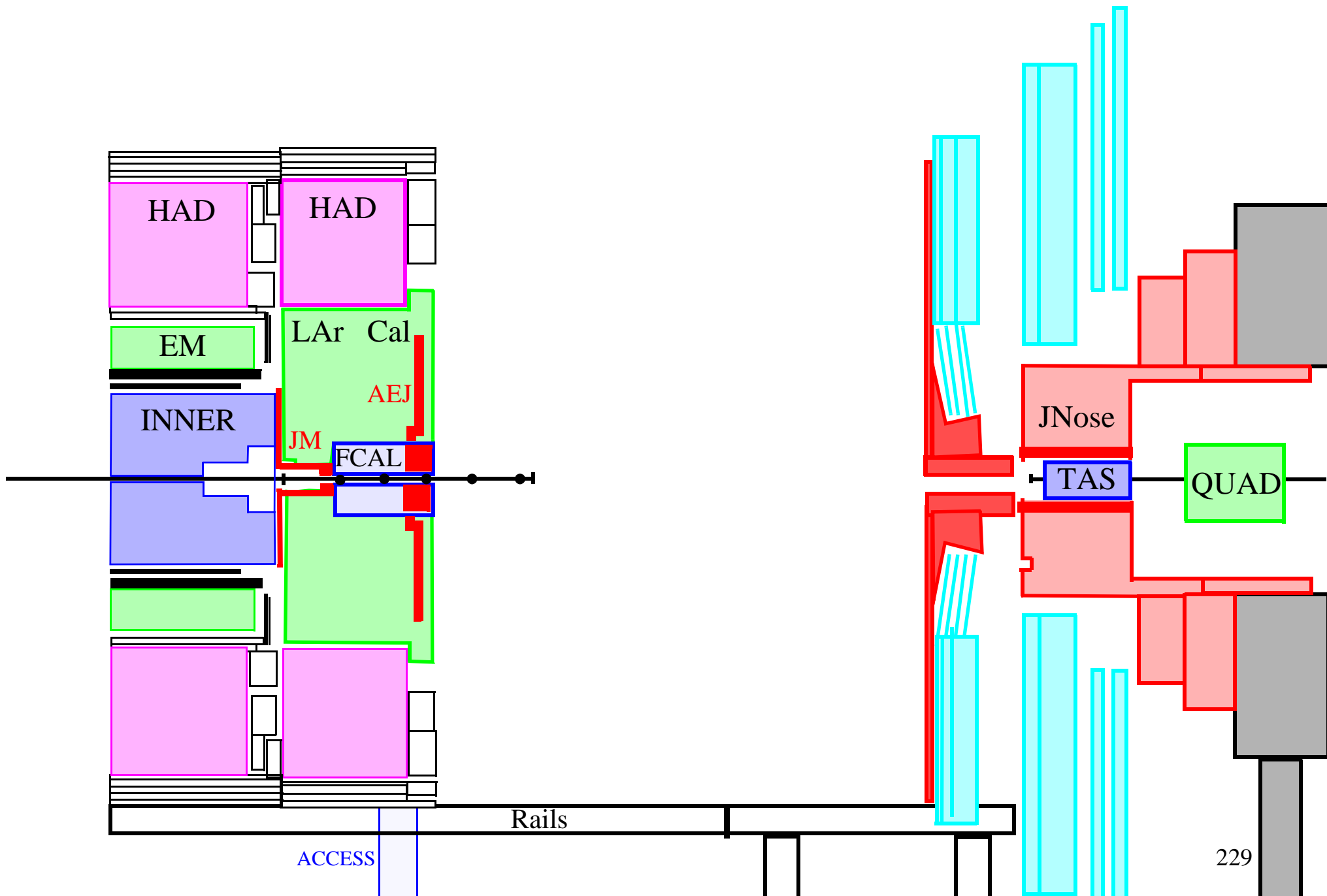

HAD

HAD

EM

LAr Cal

INNER

AEJ

JM

FCAL

JNose

TAS

QUAD

Rails

ACCESS

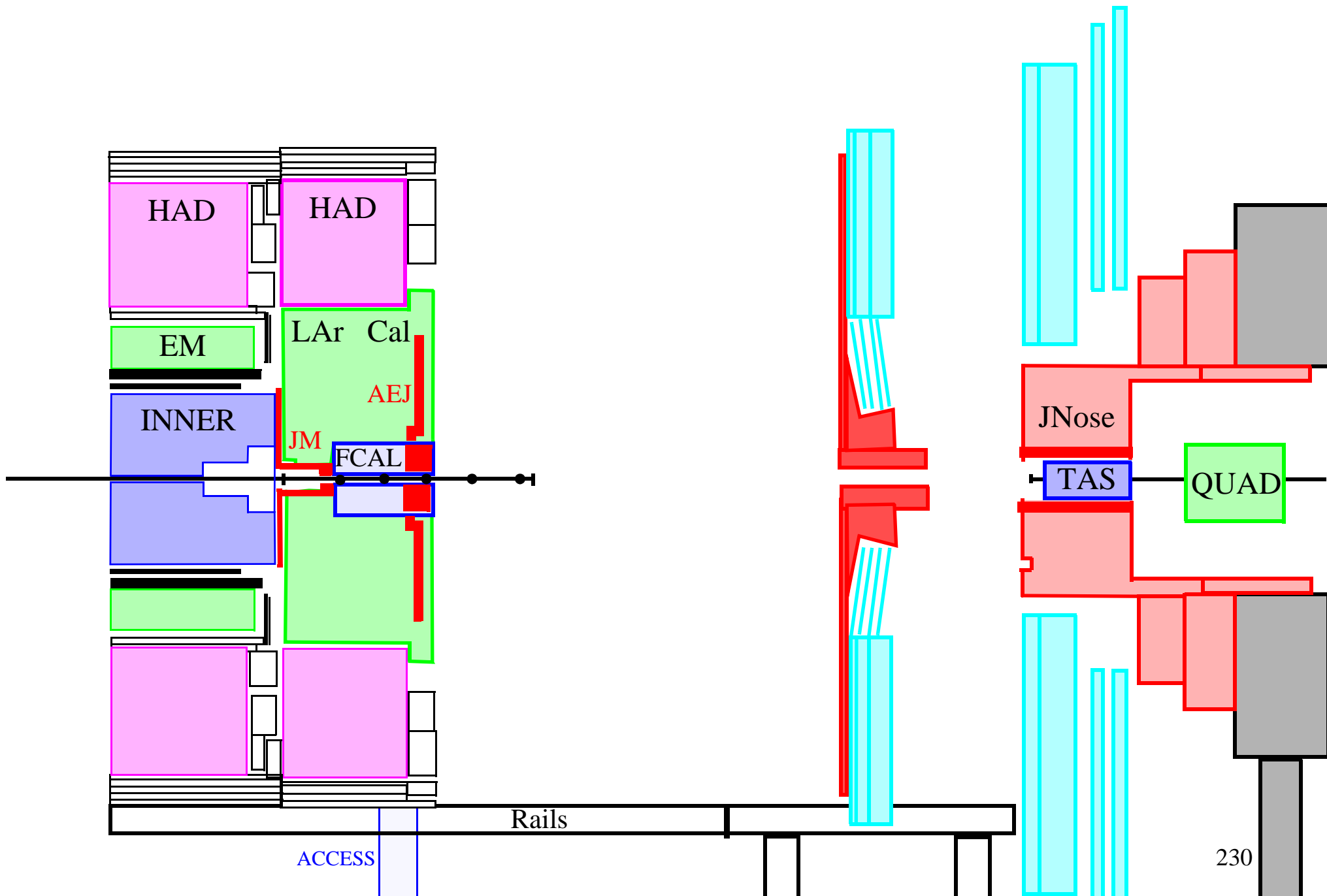

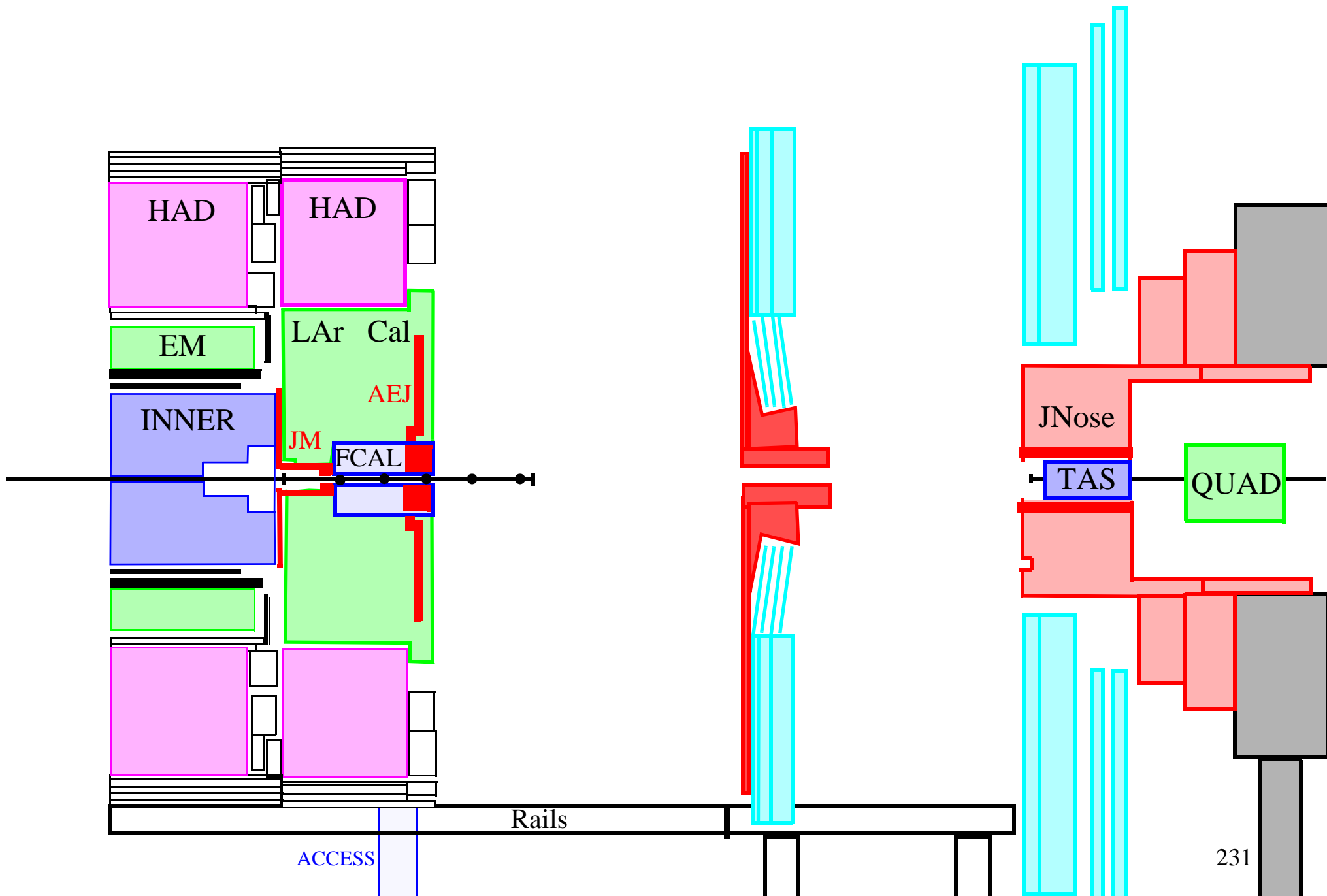

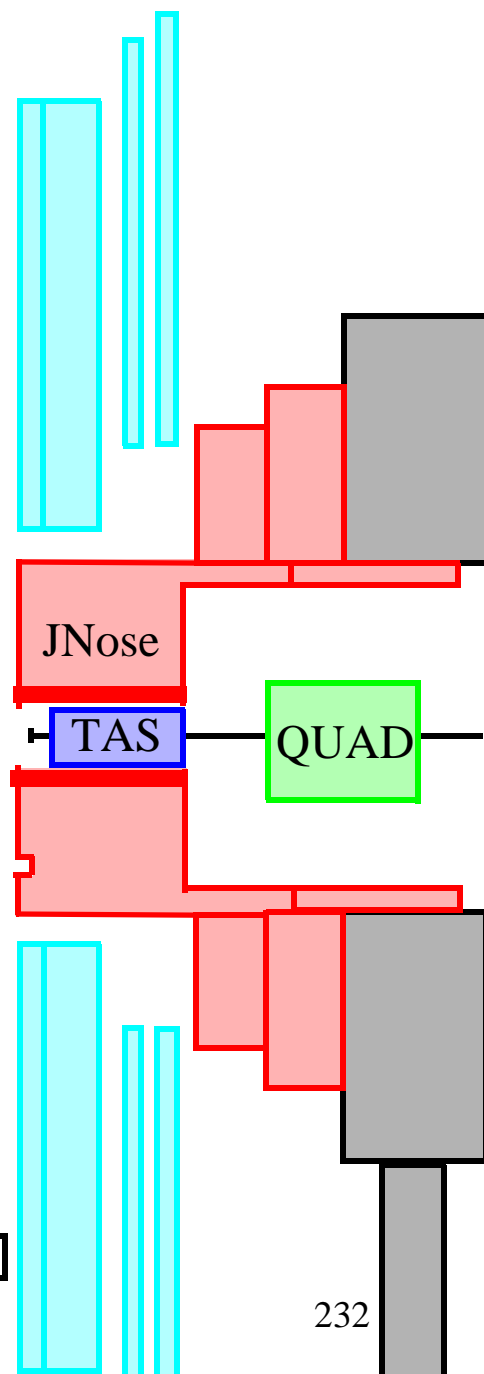
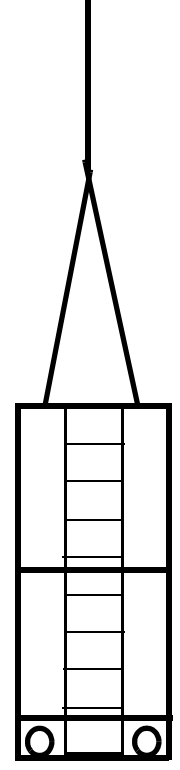
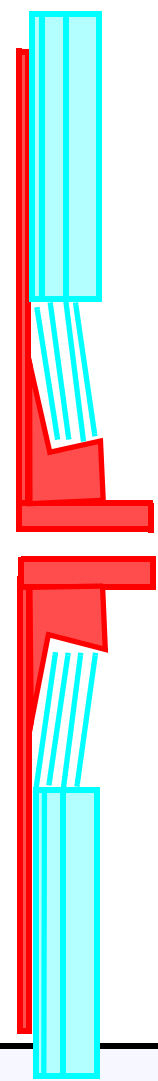
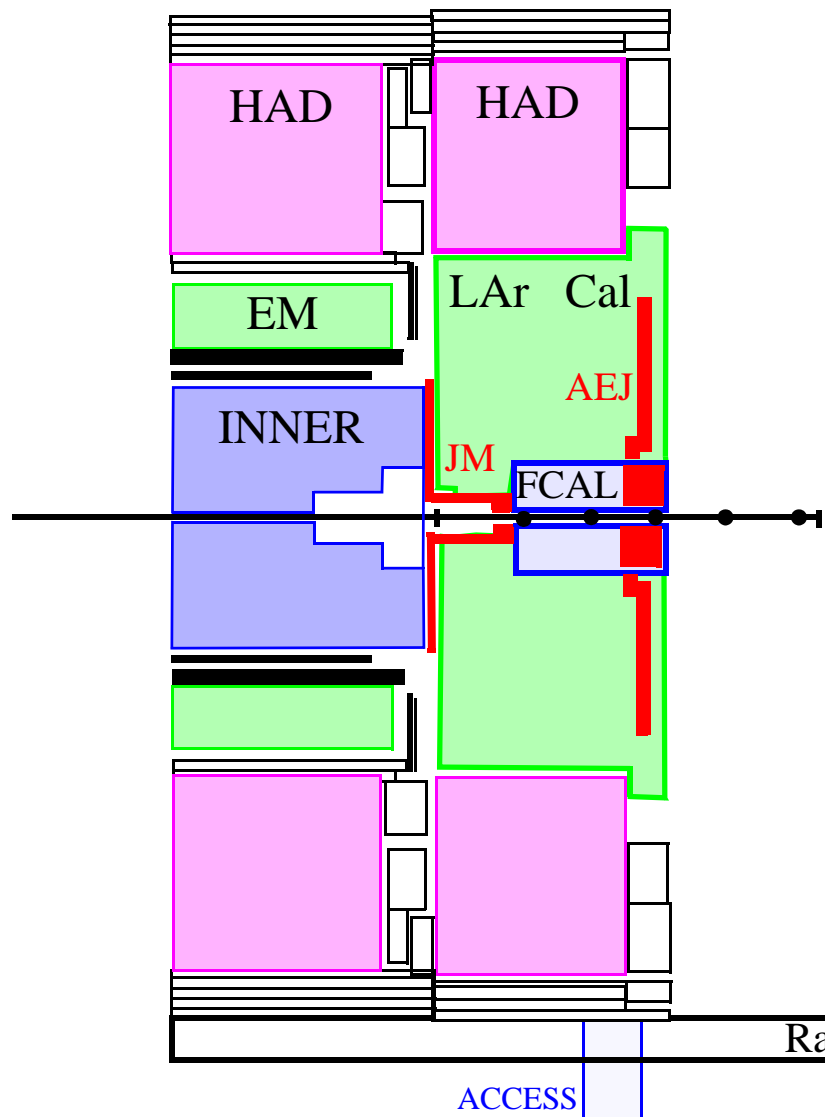

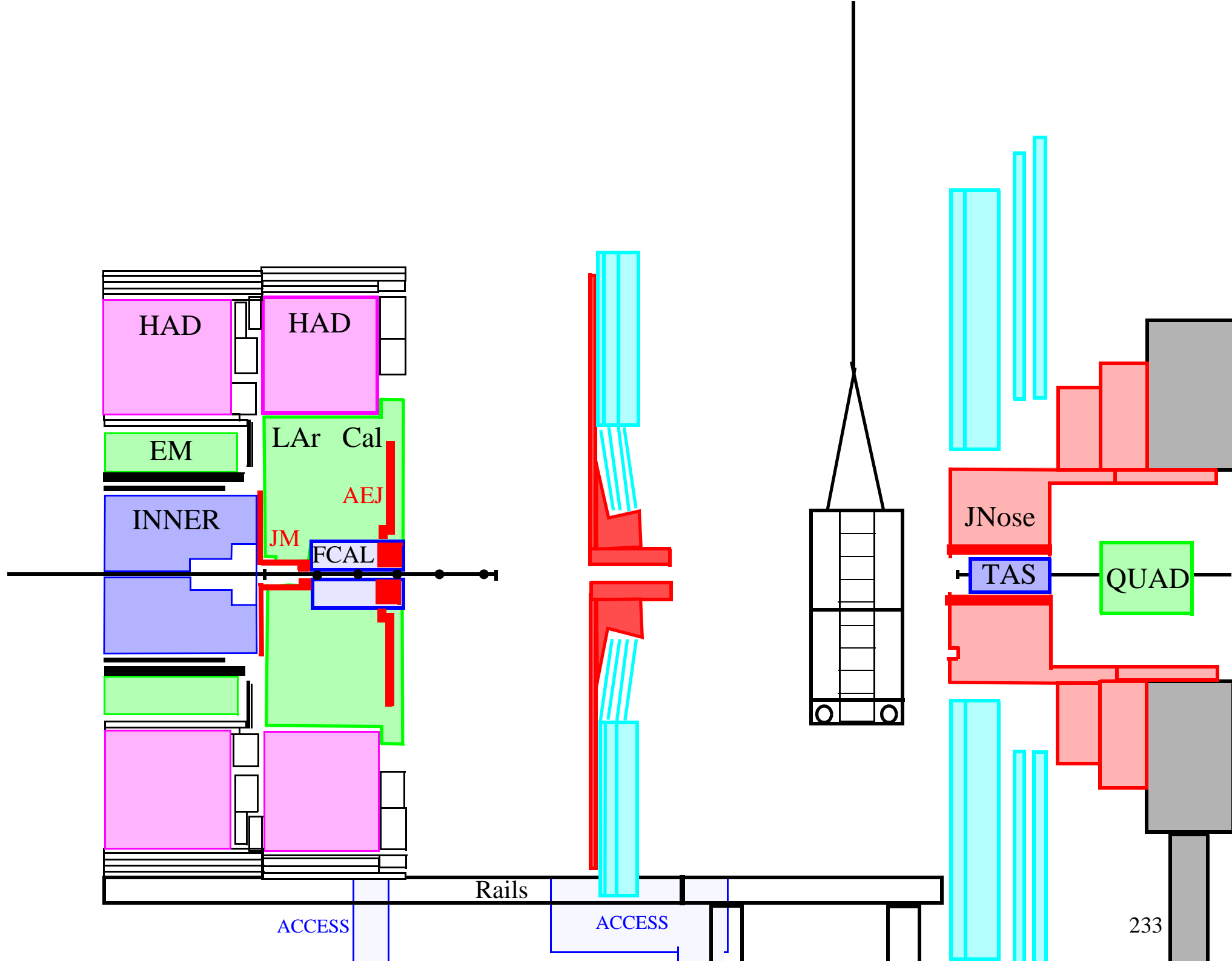

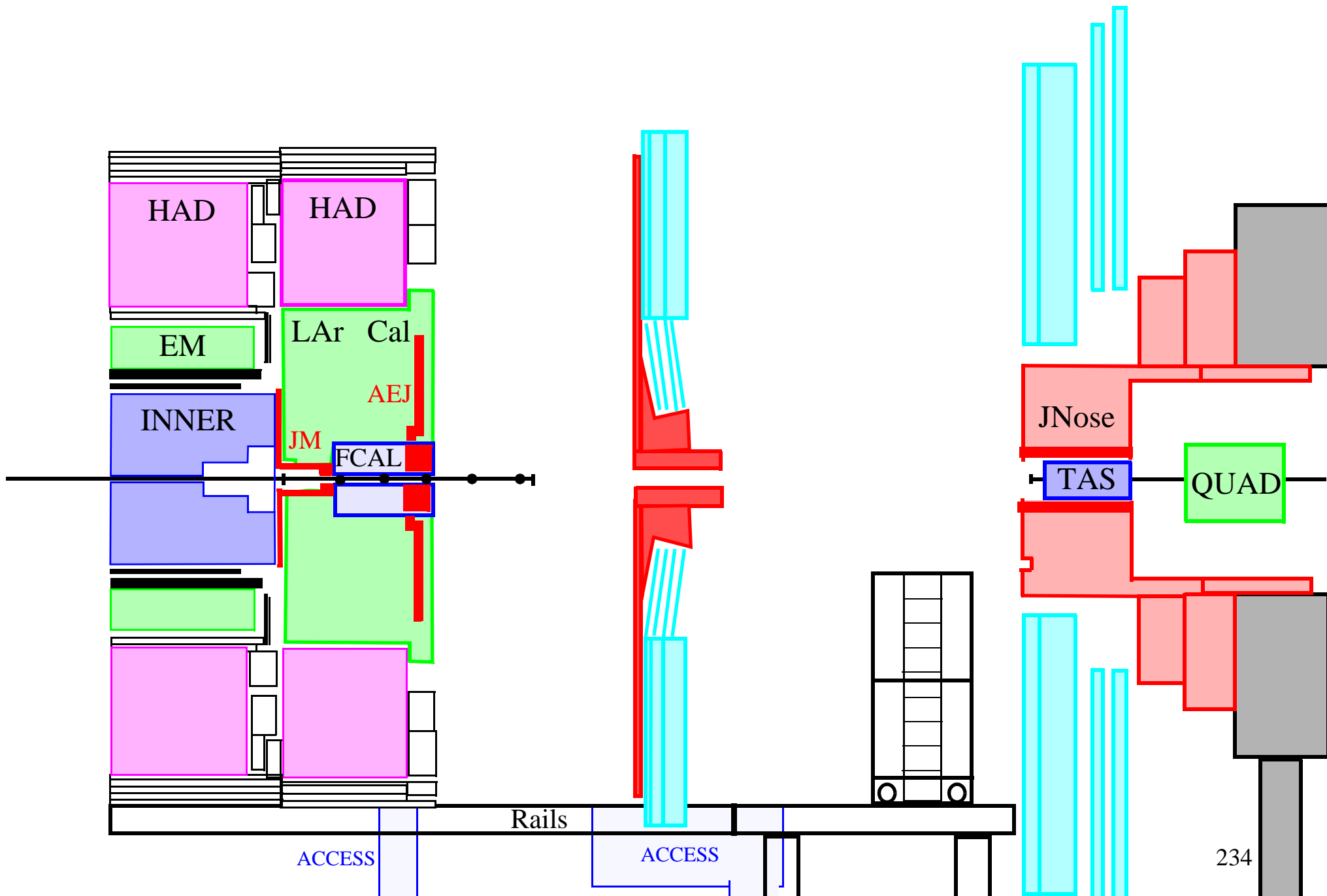

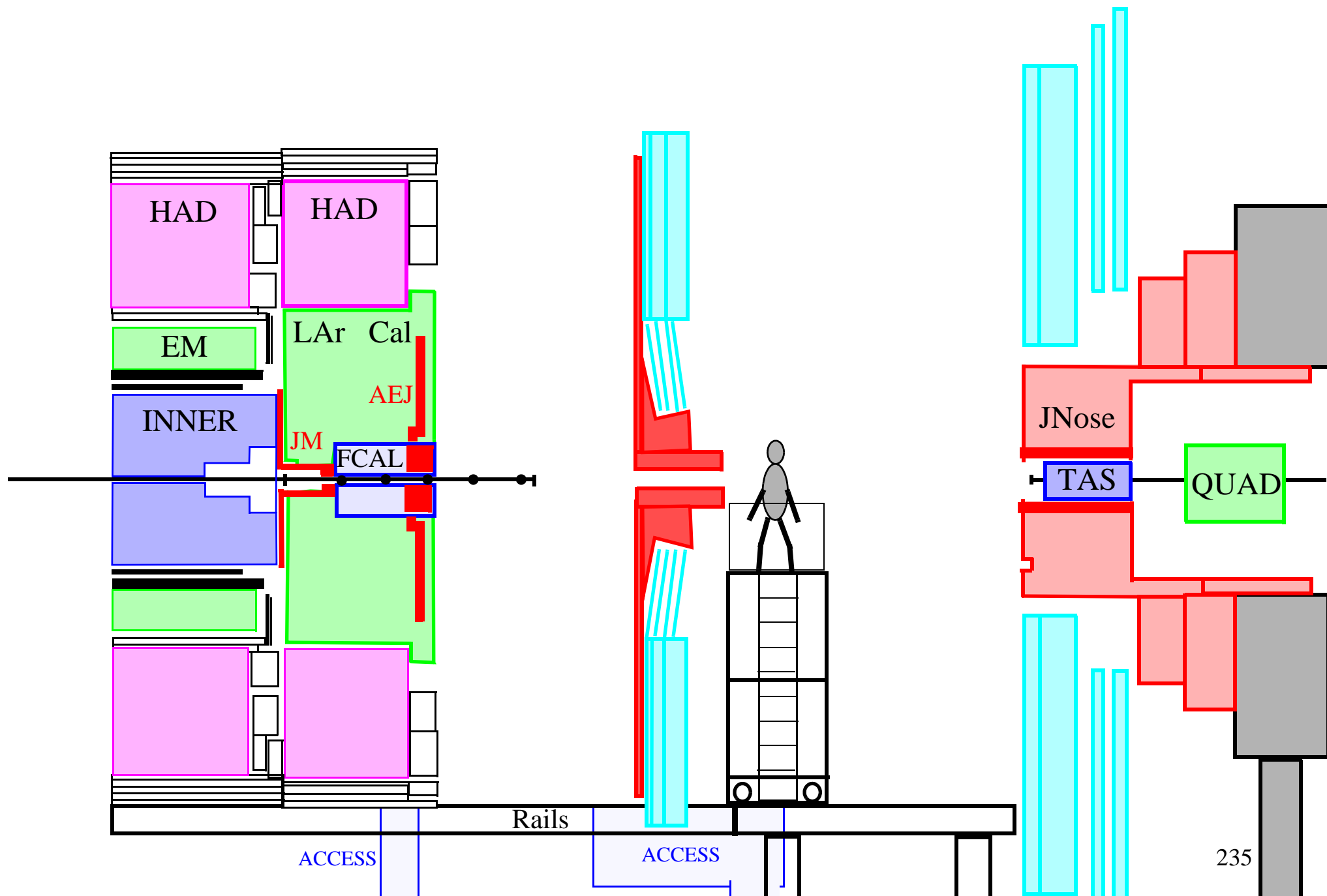

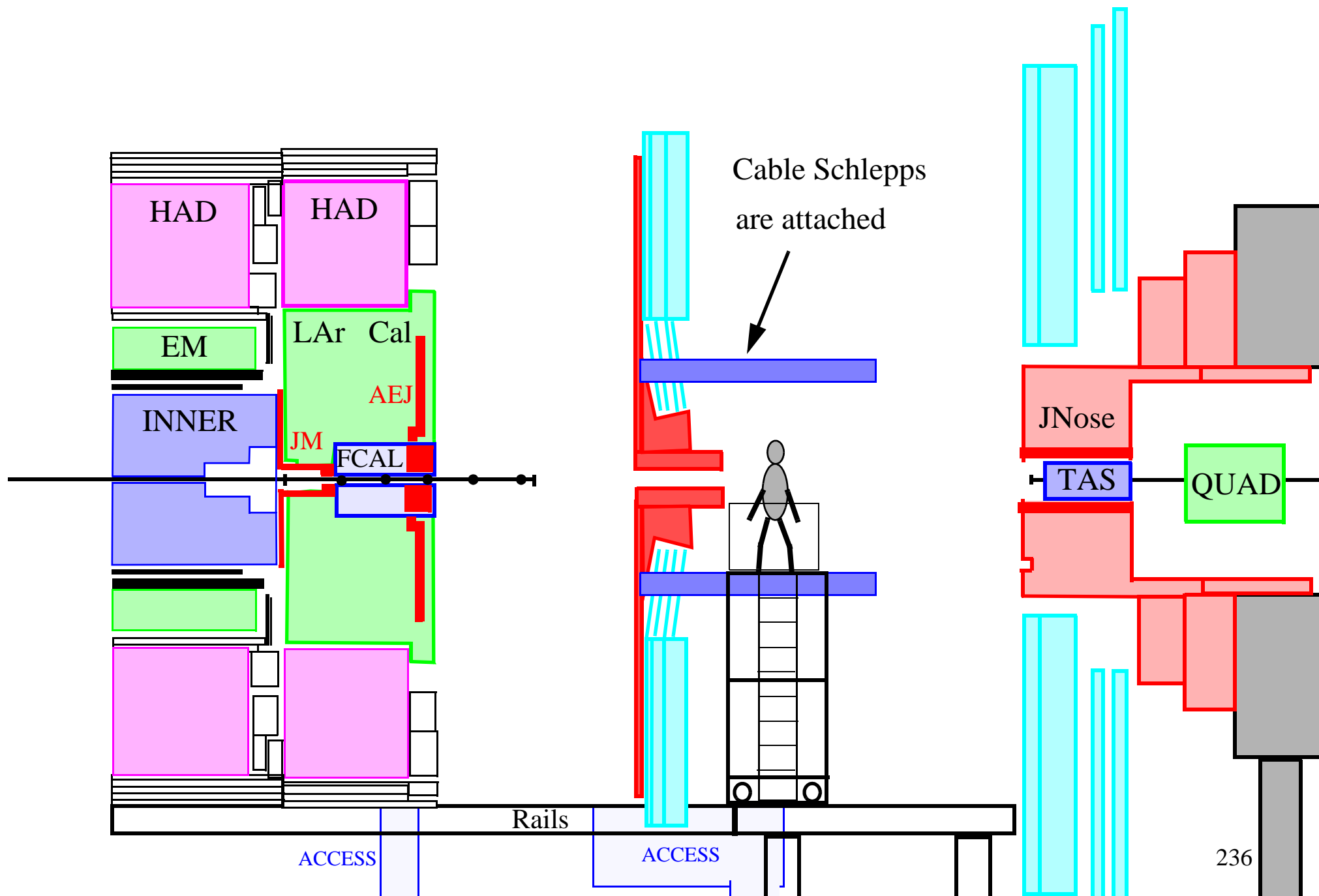

SERVICES TRAYS

MDT ROUTING

Cable Schlepps

CSC ROUTING

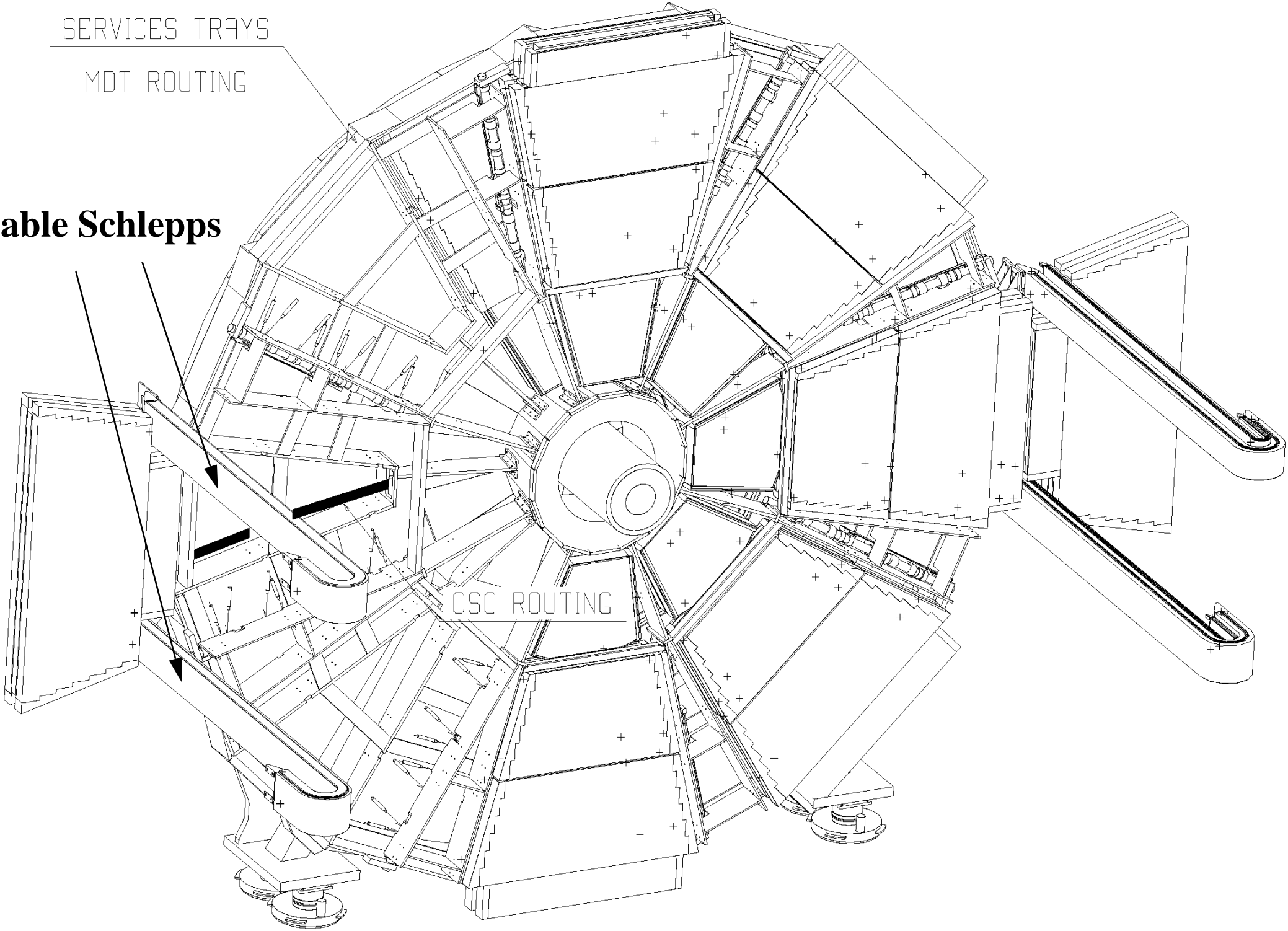

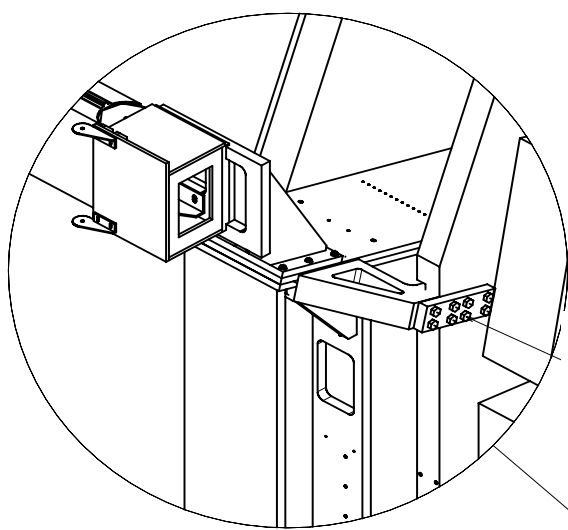

3 attachments
to the SW

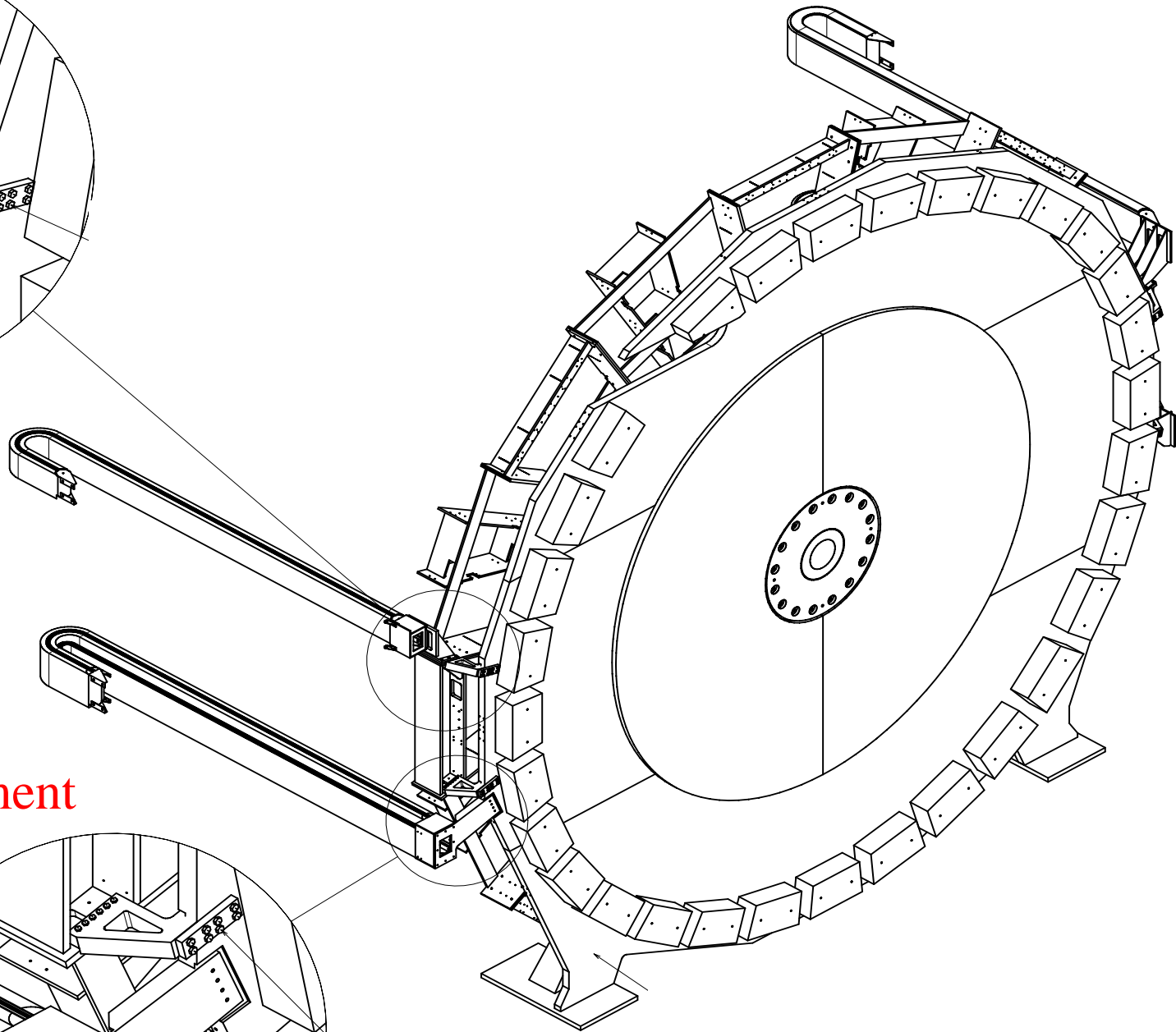

One attachment
to the JD.

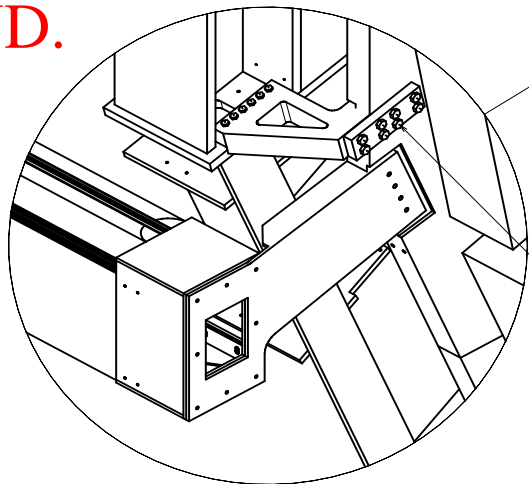

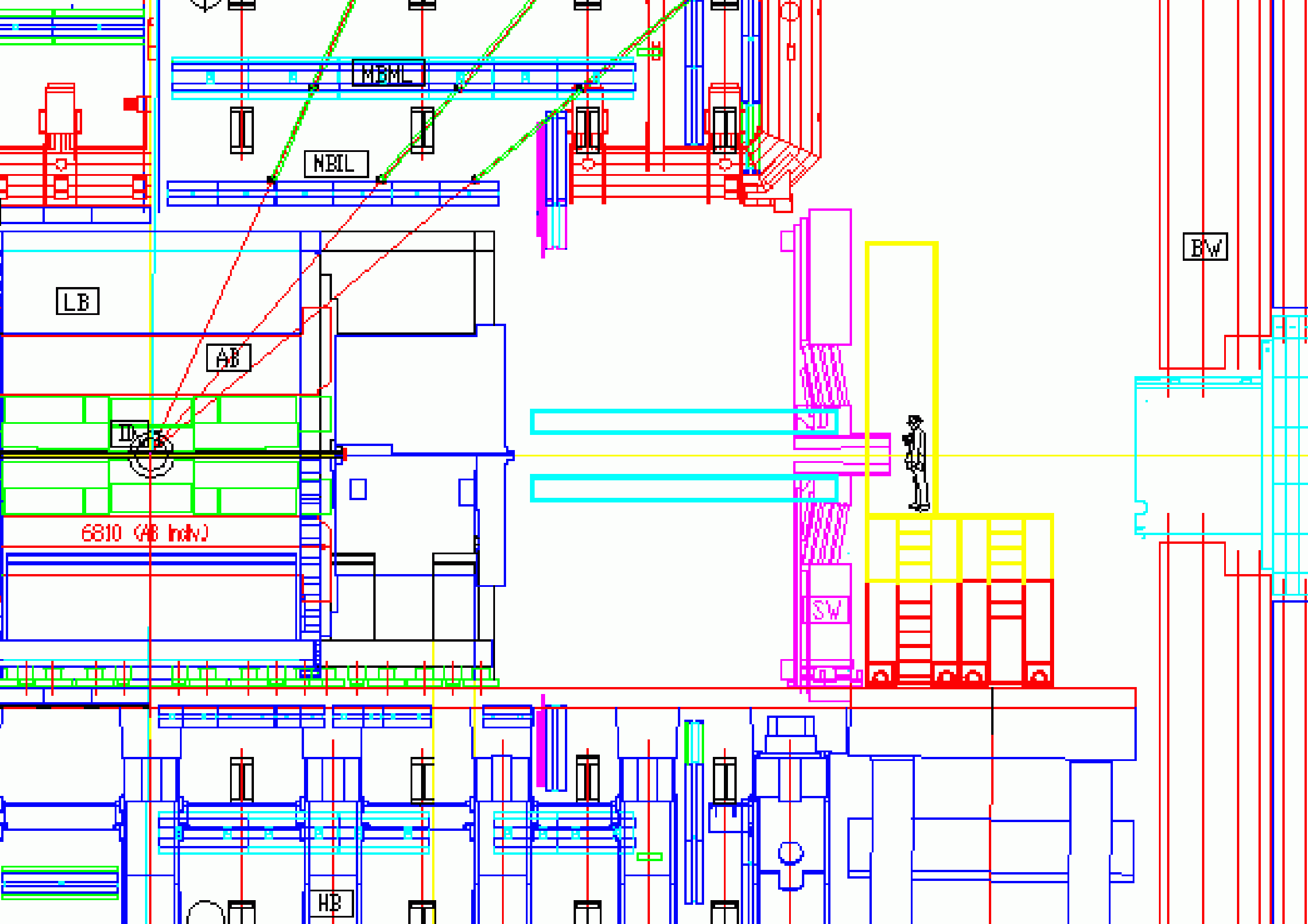

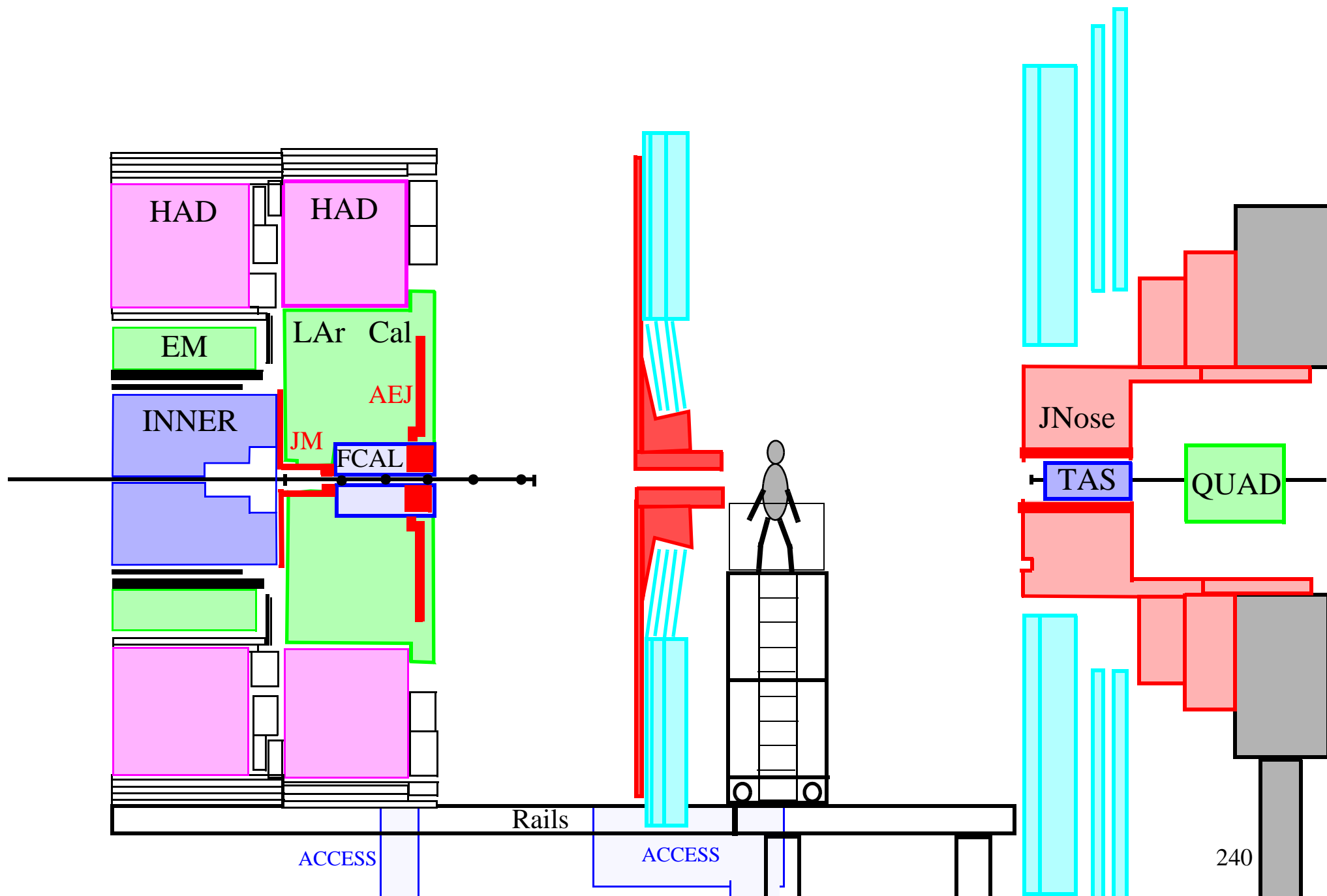

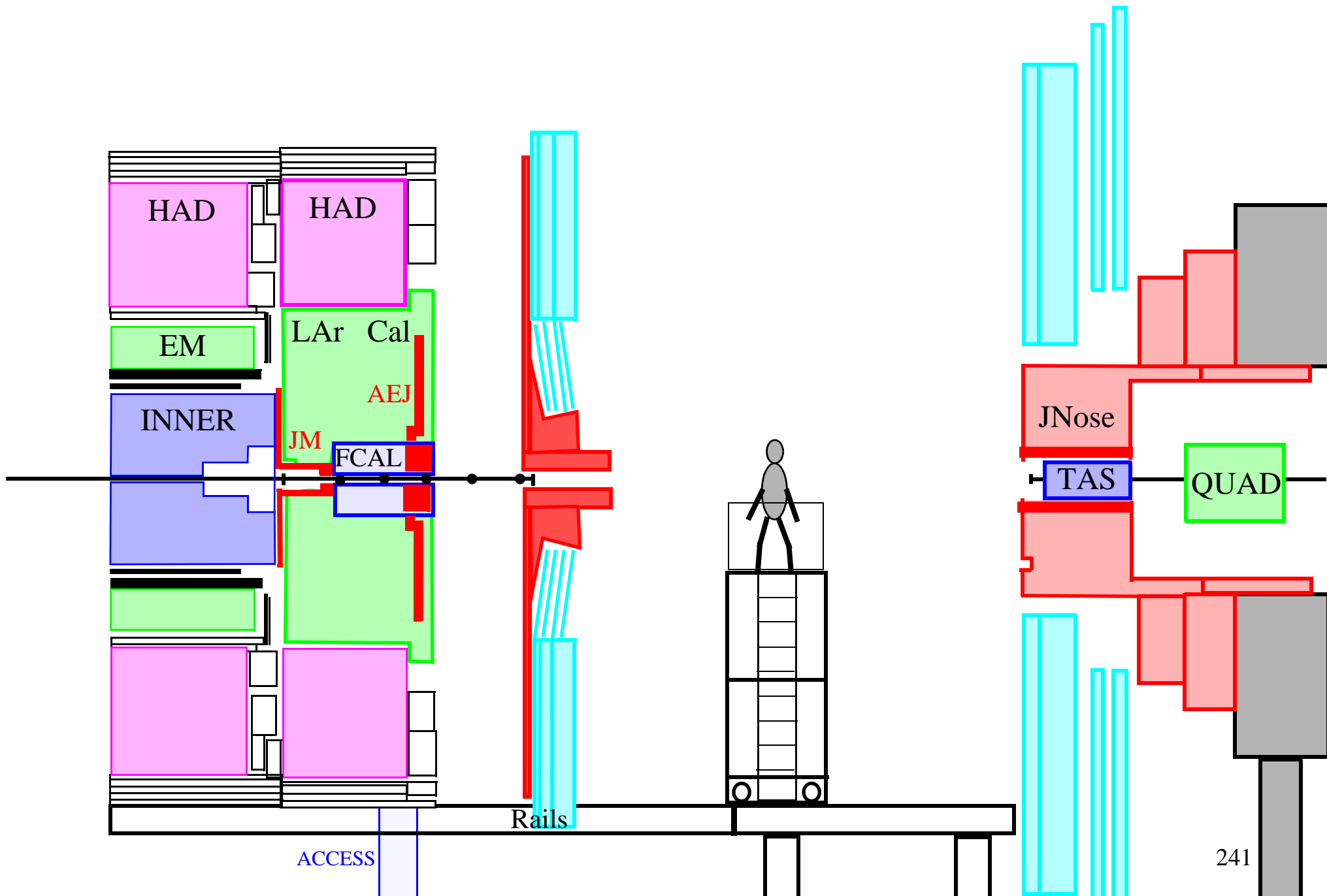

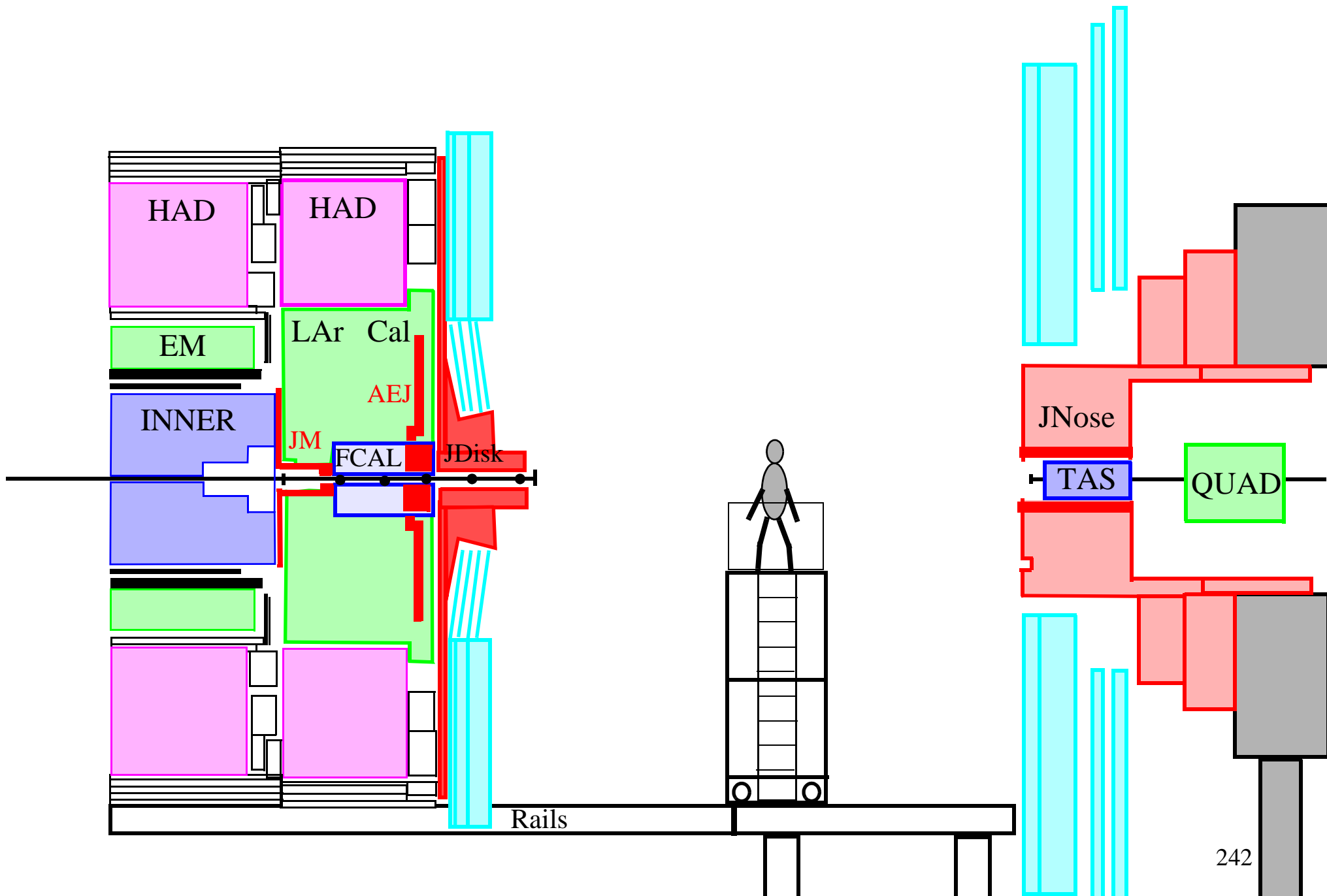

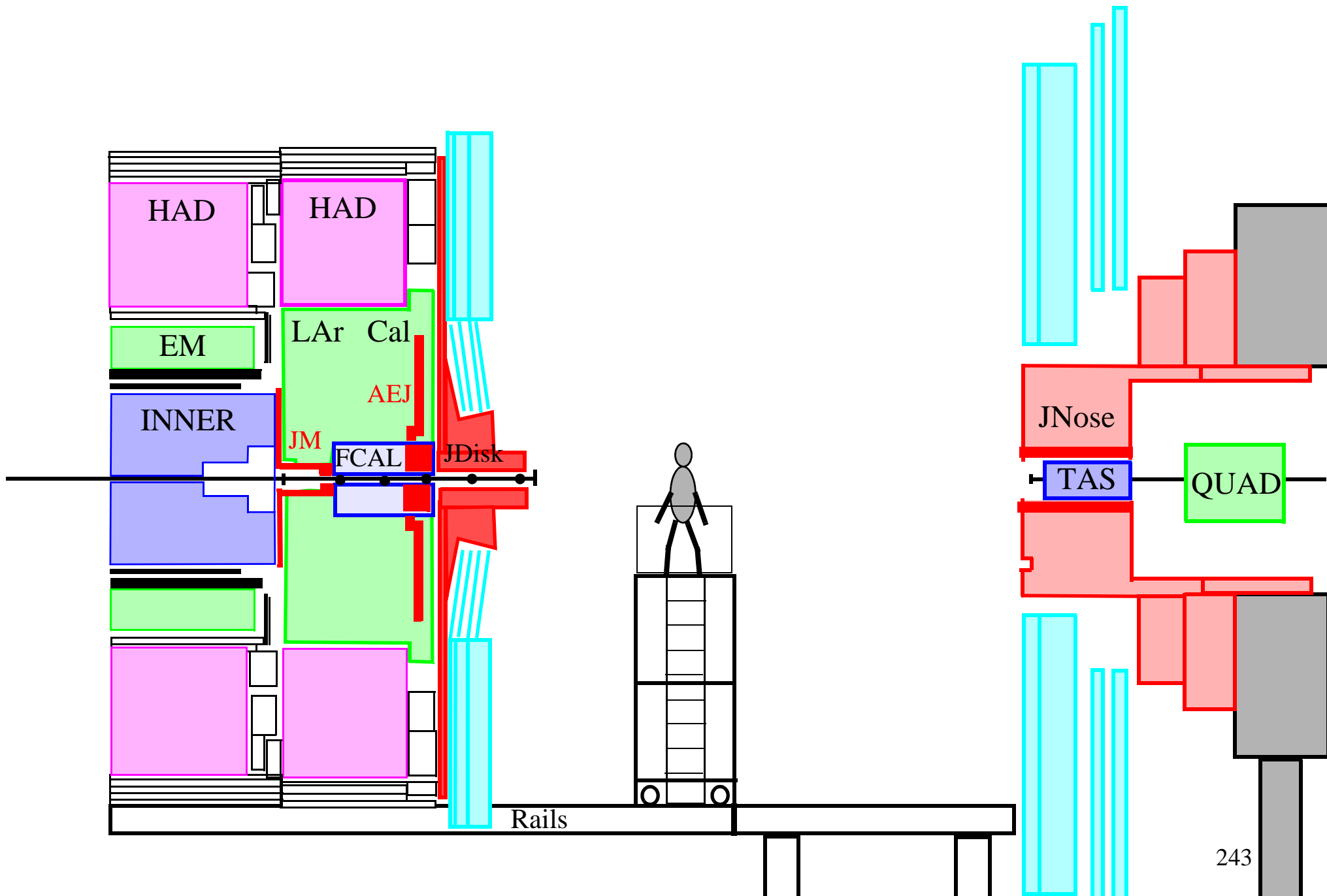

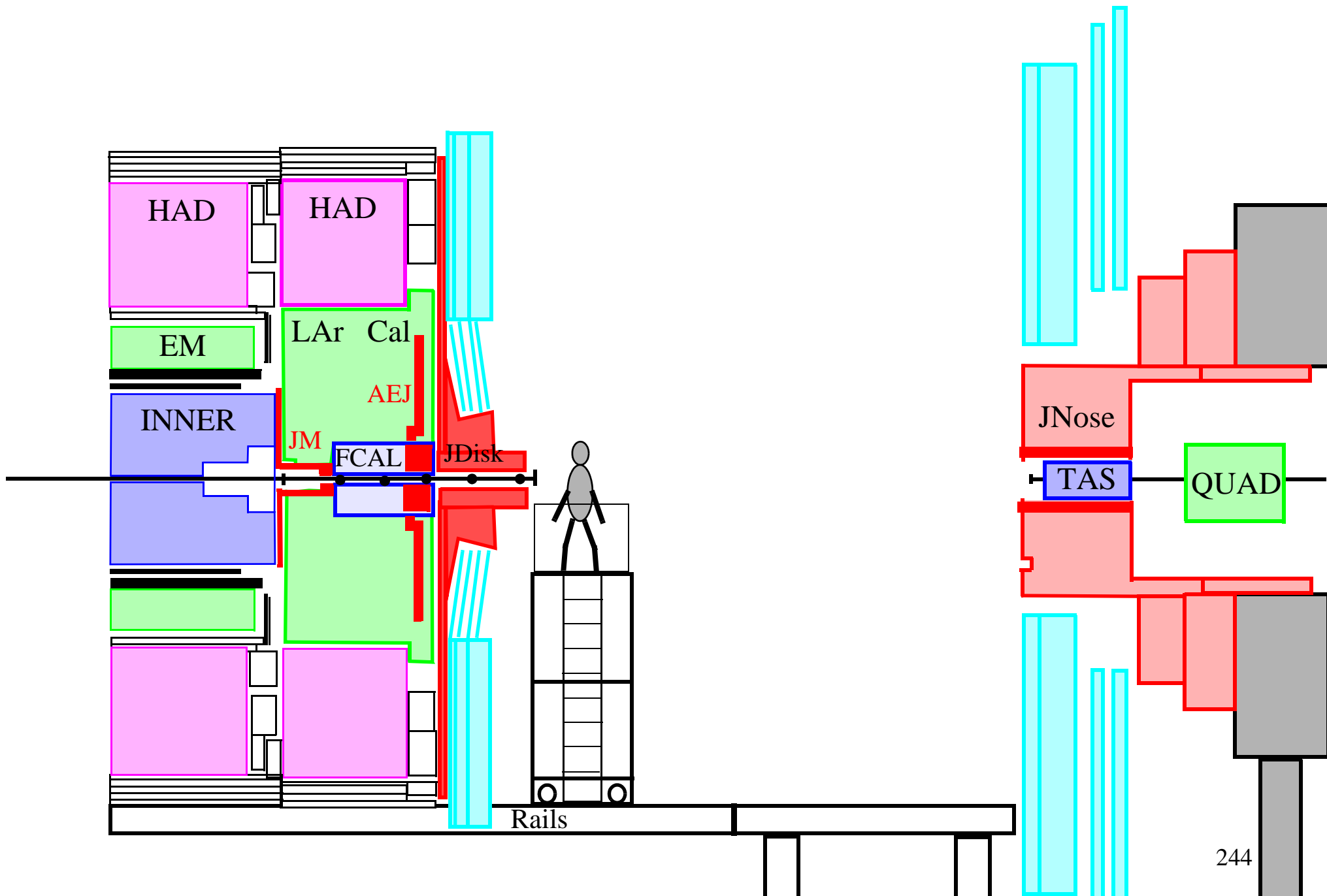

Beampipe supports

This support has to be attached.

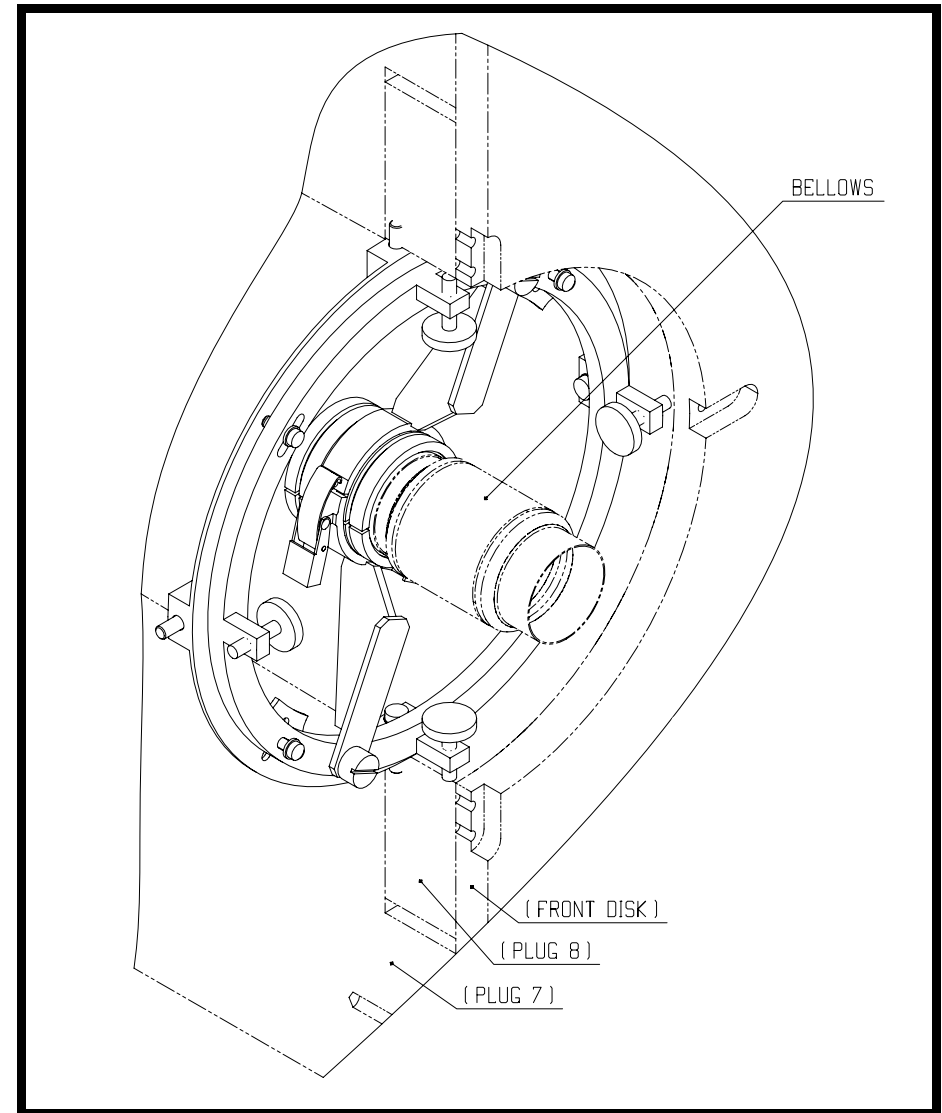
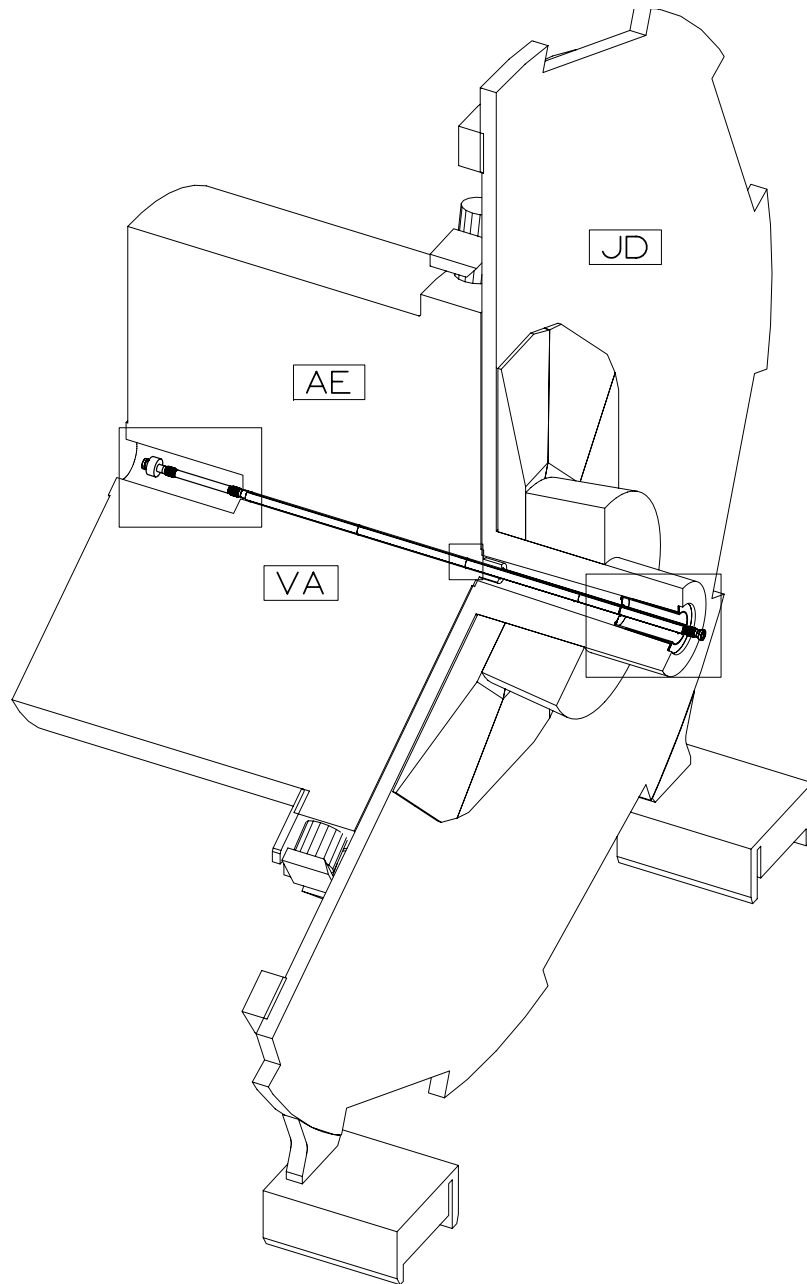

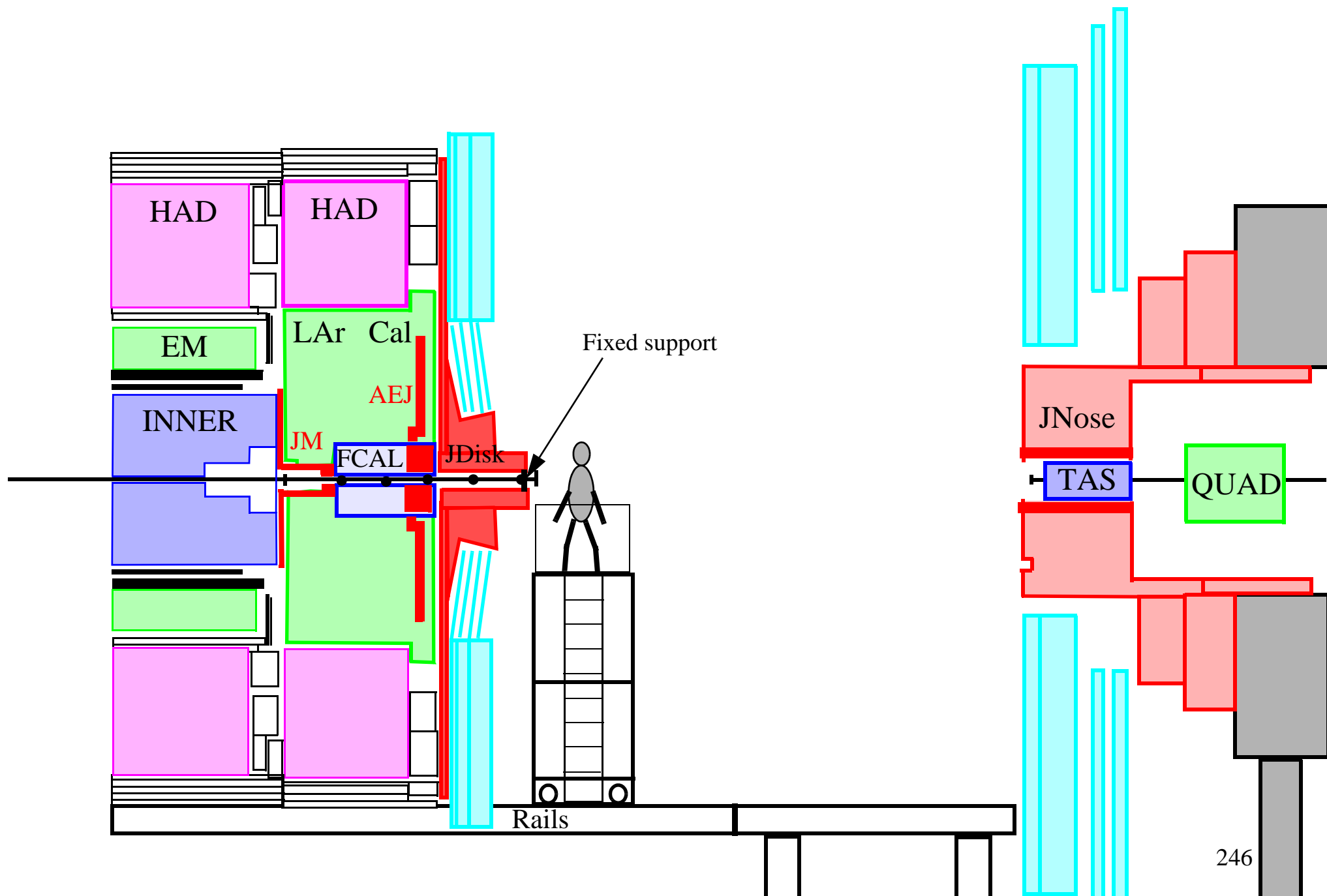

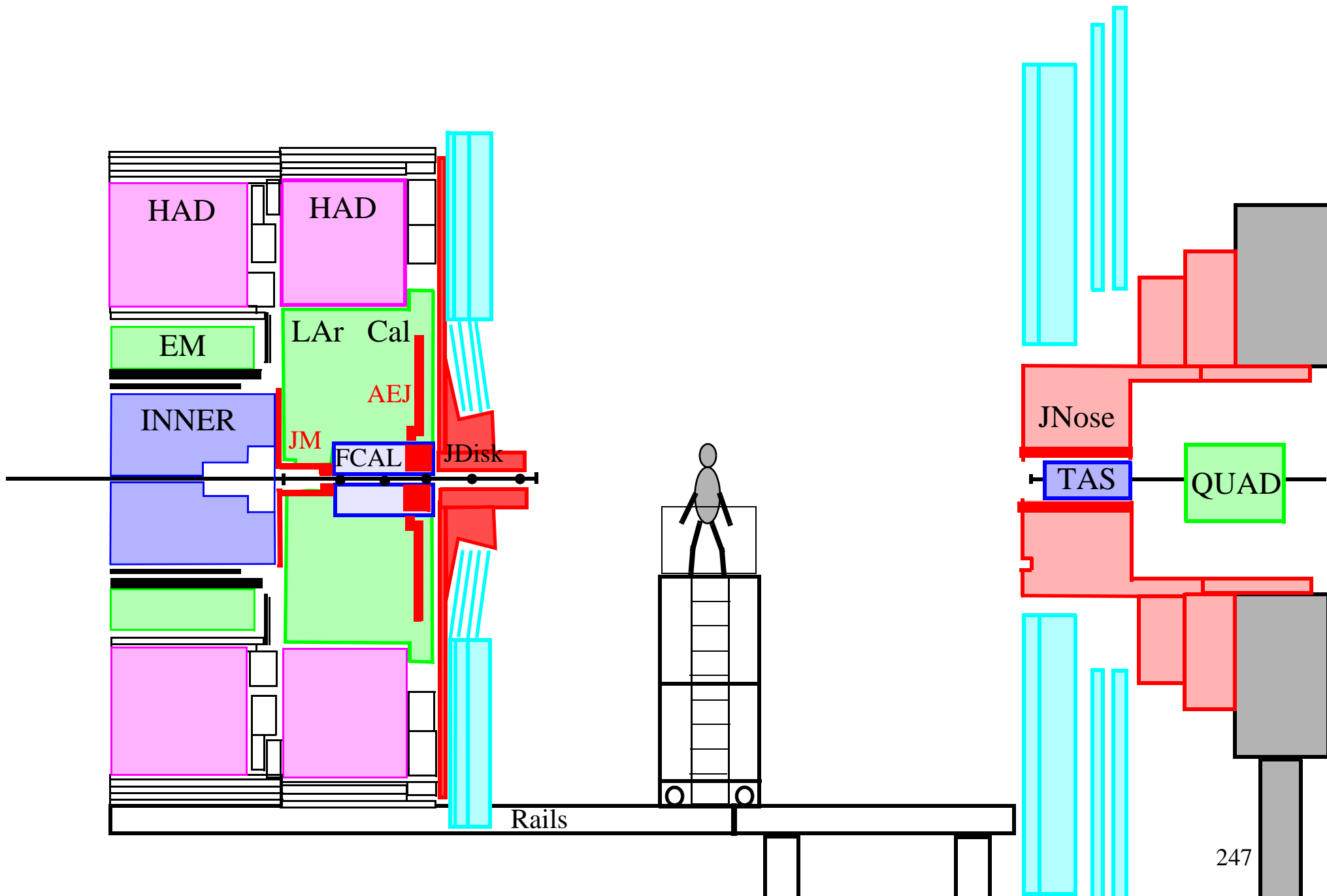

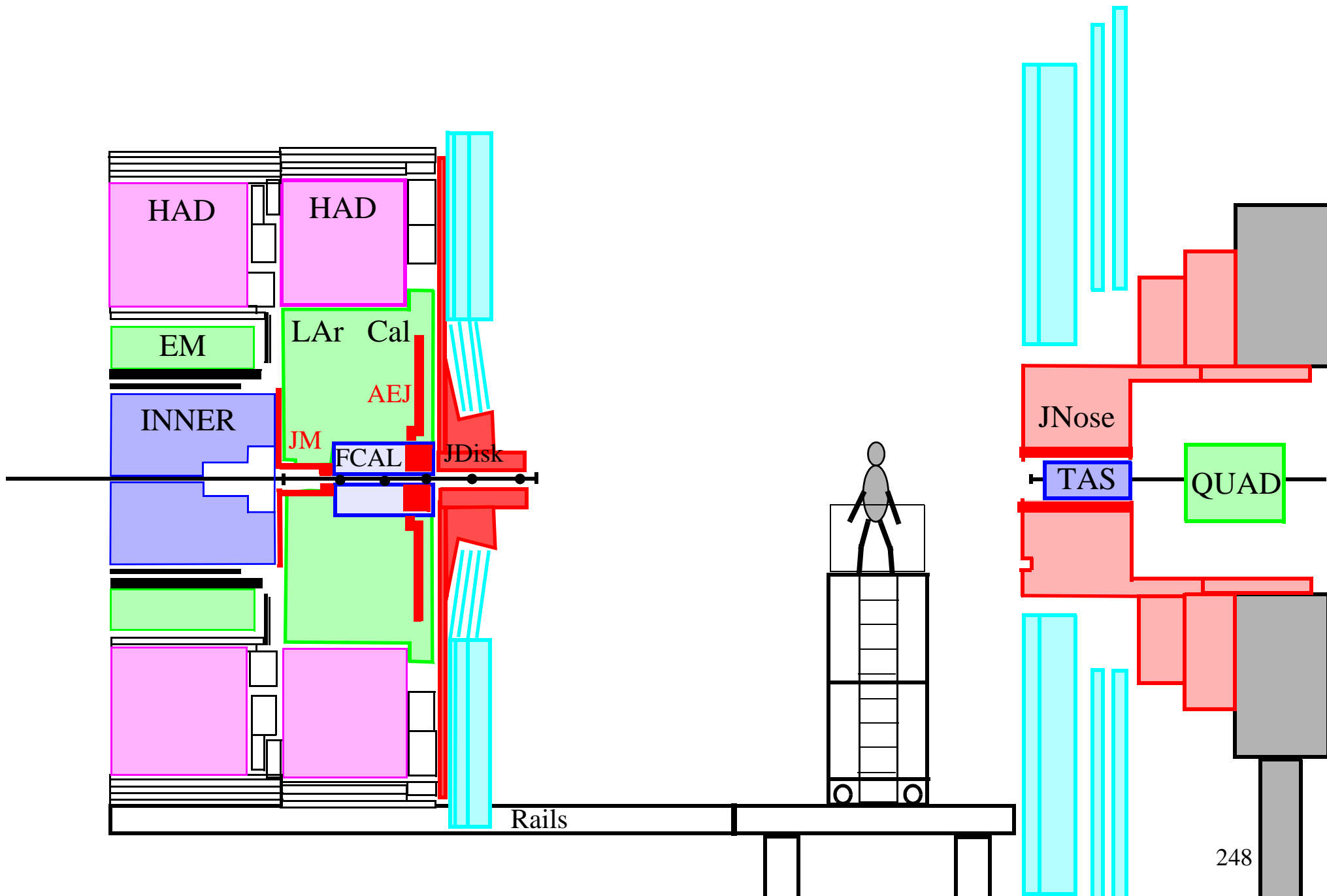

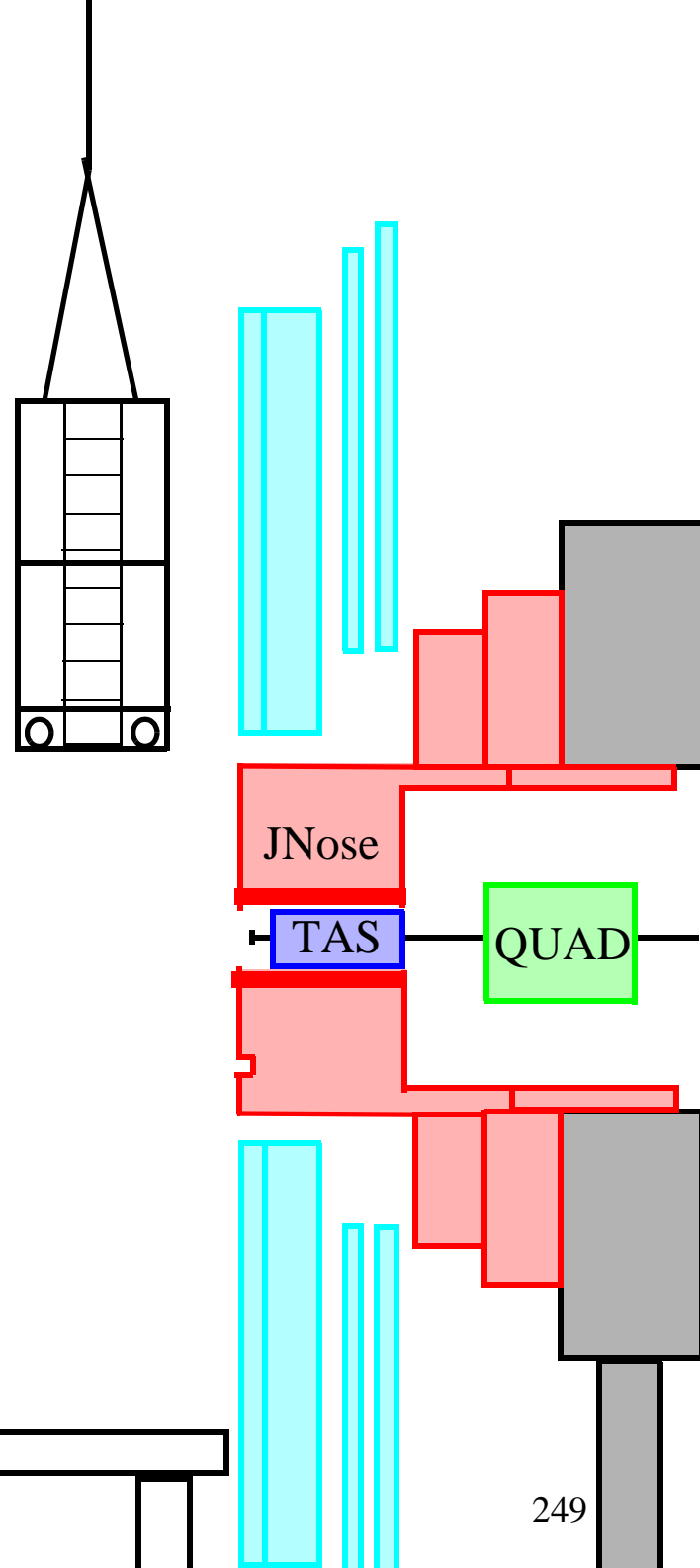
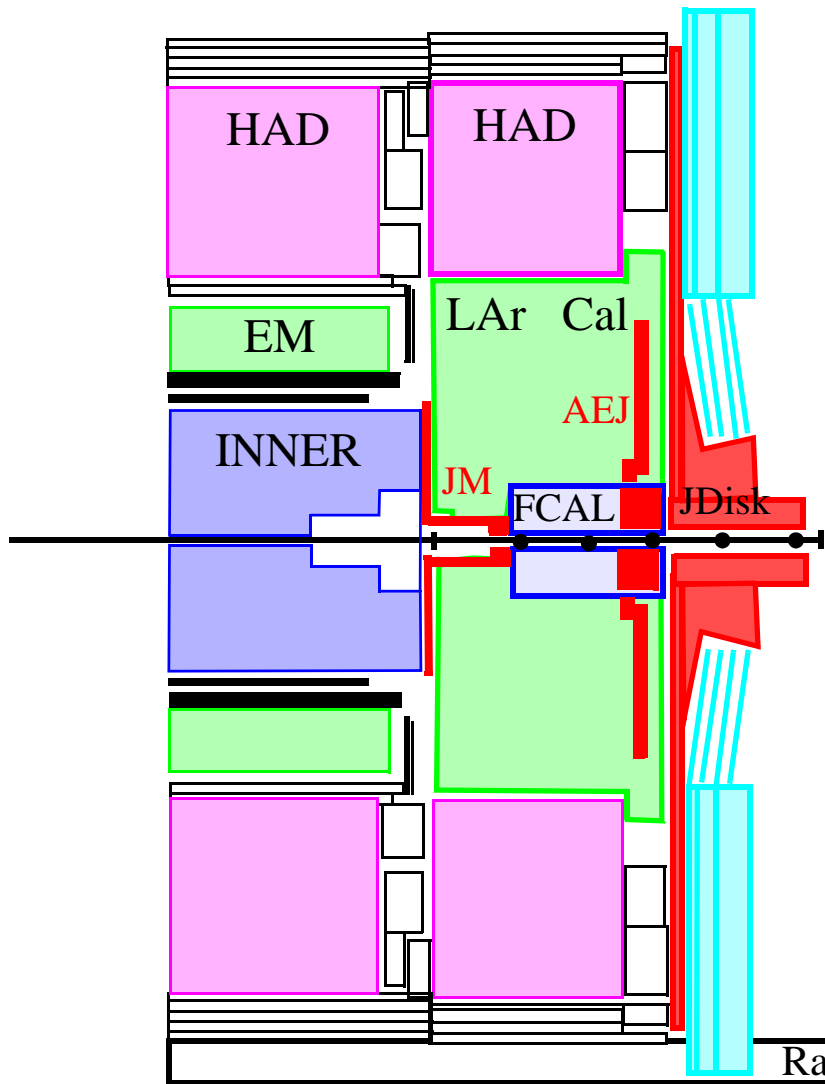

May 2007

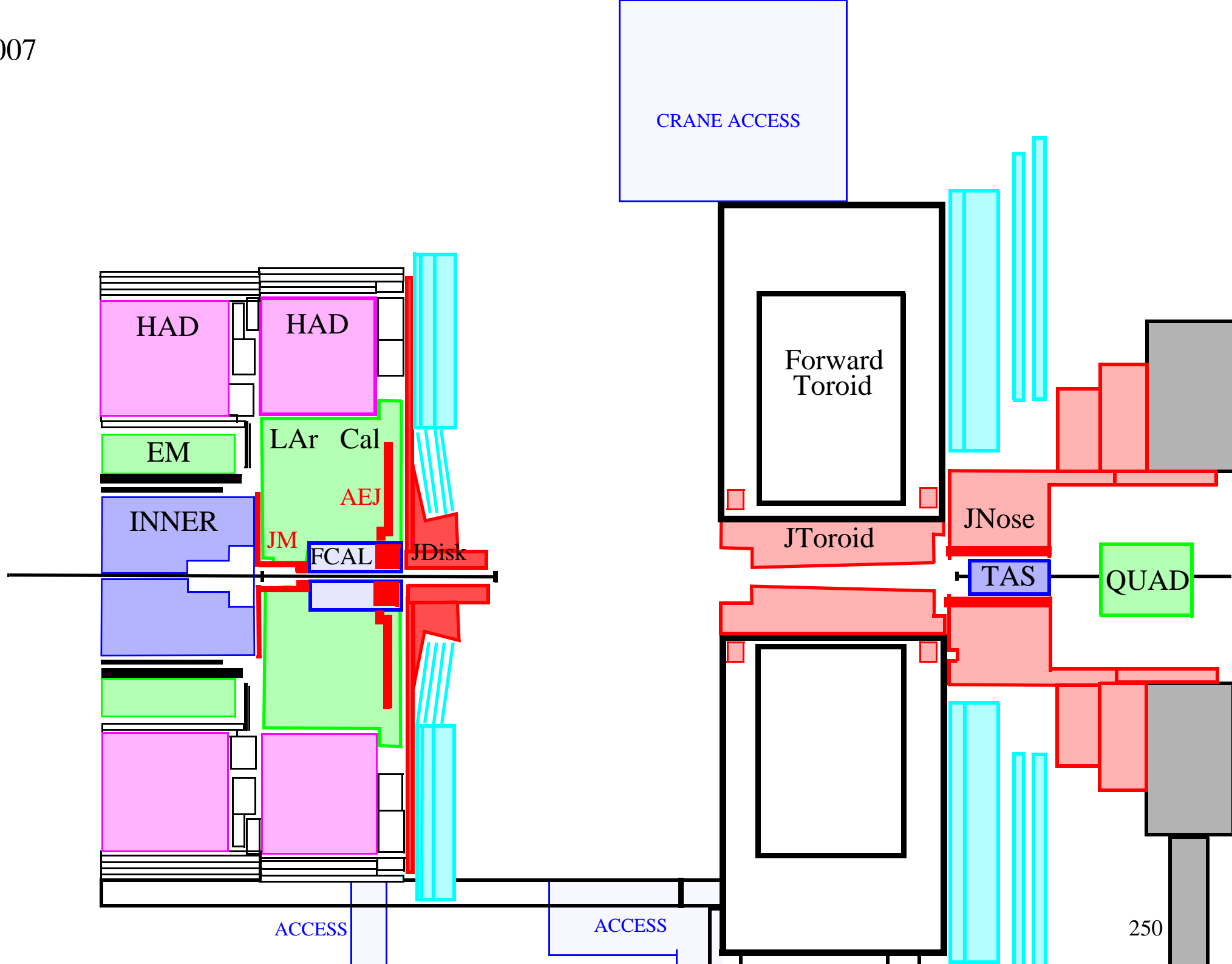

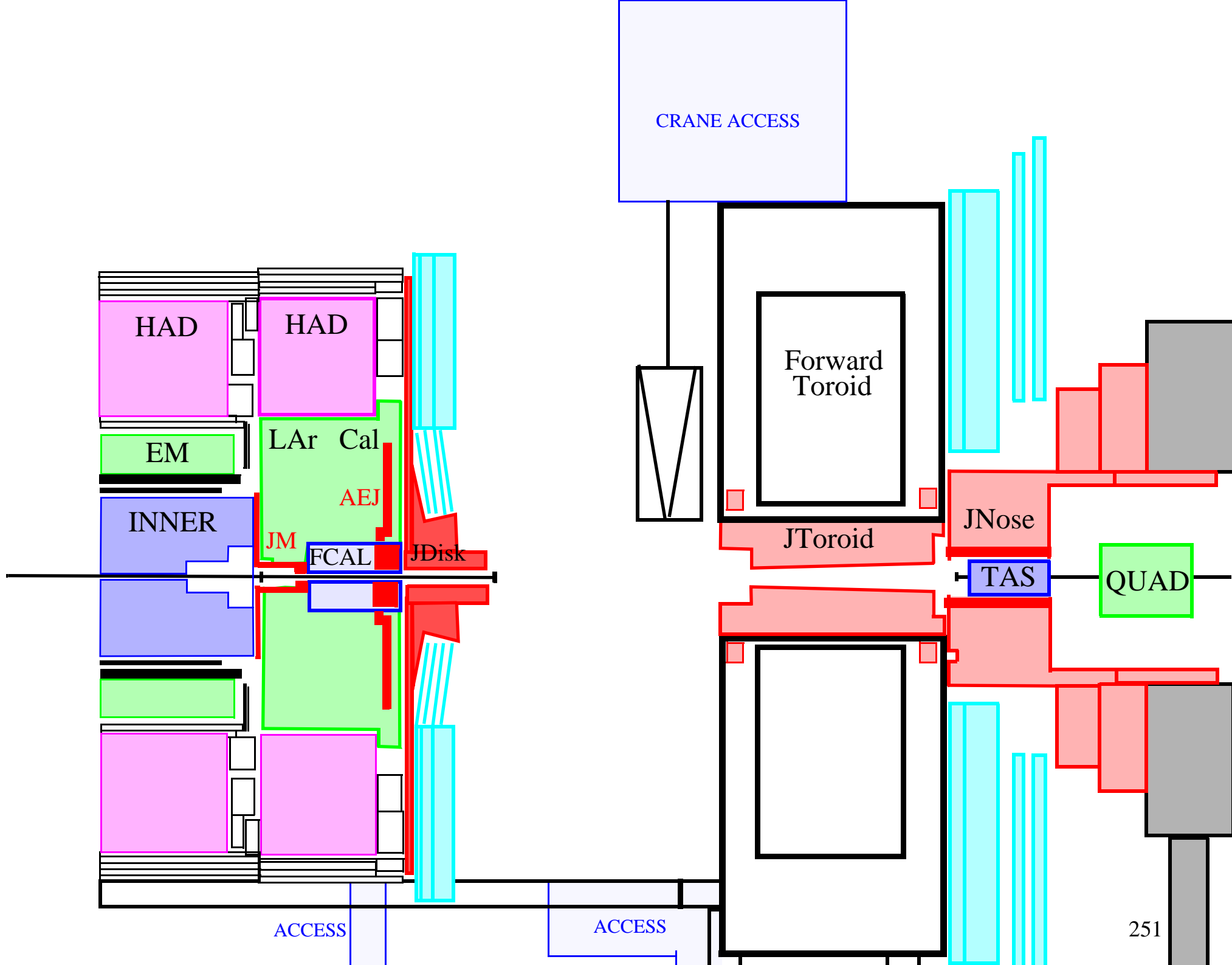

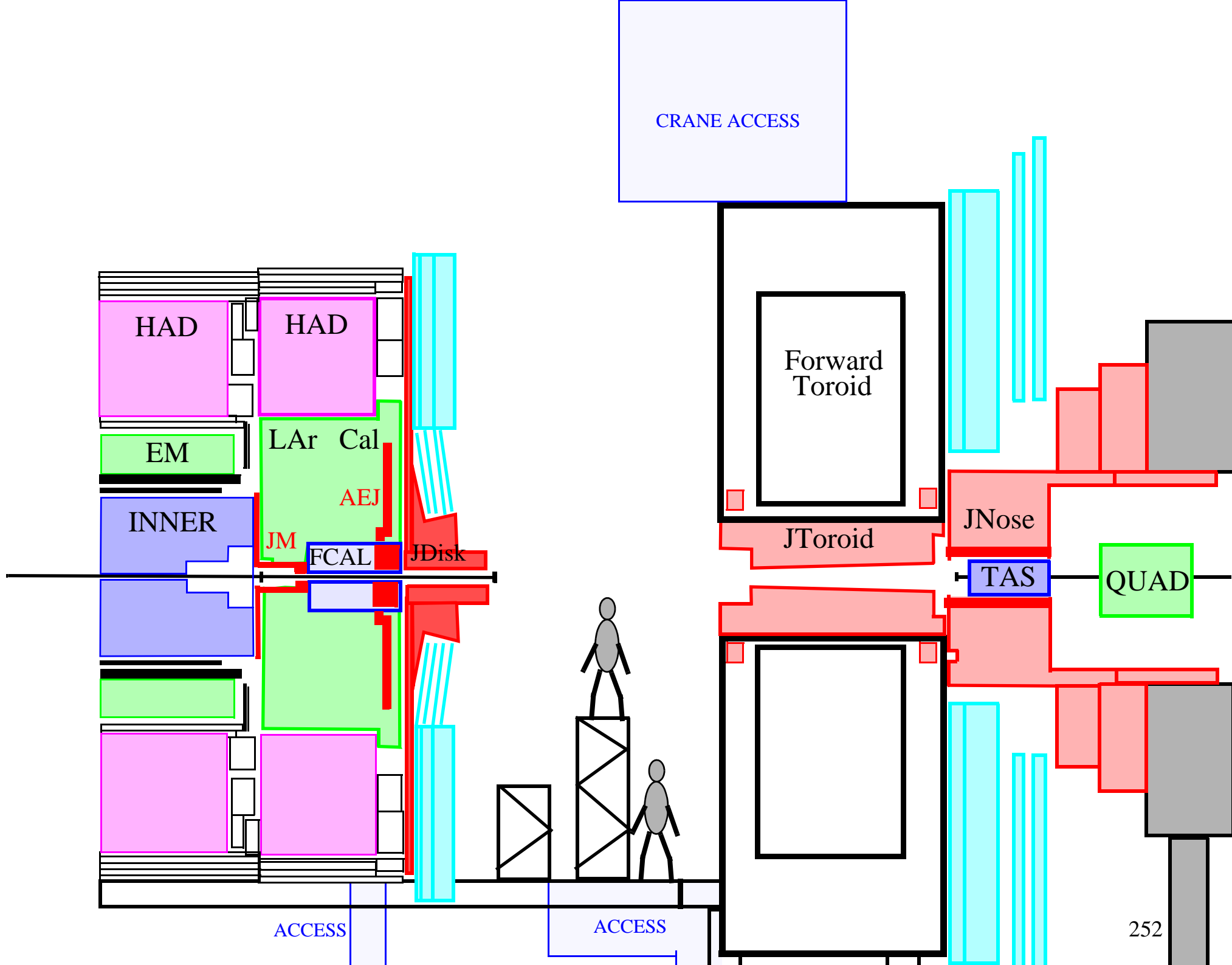

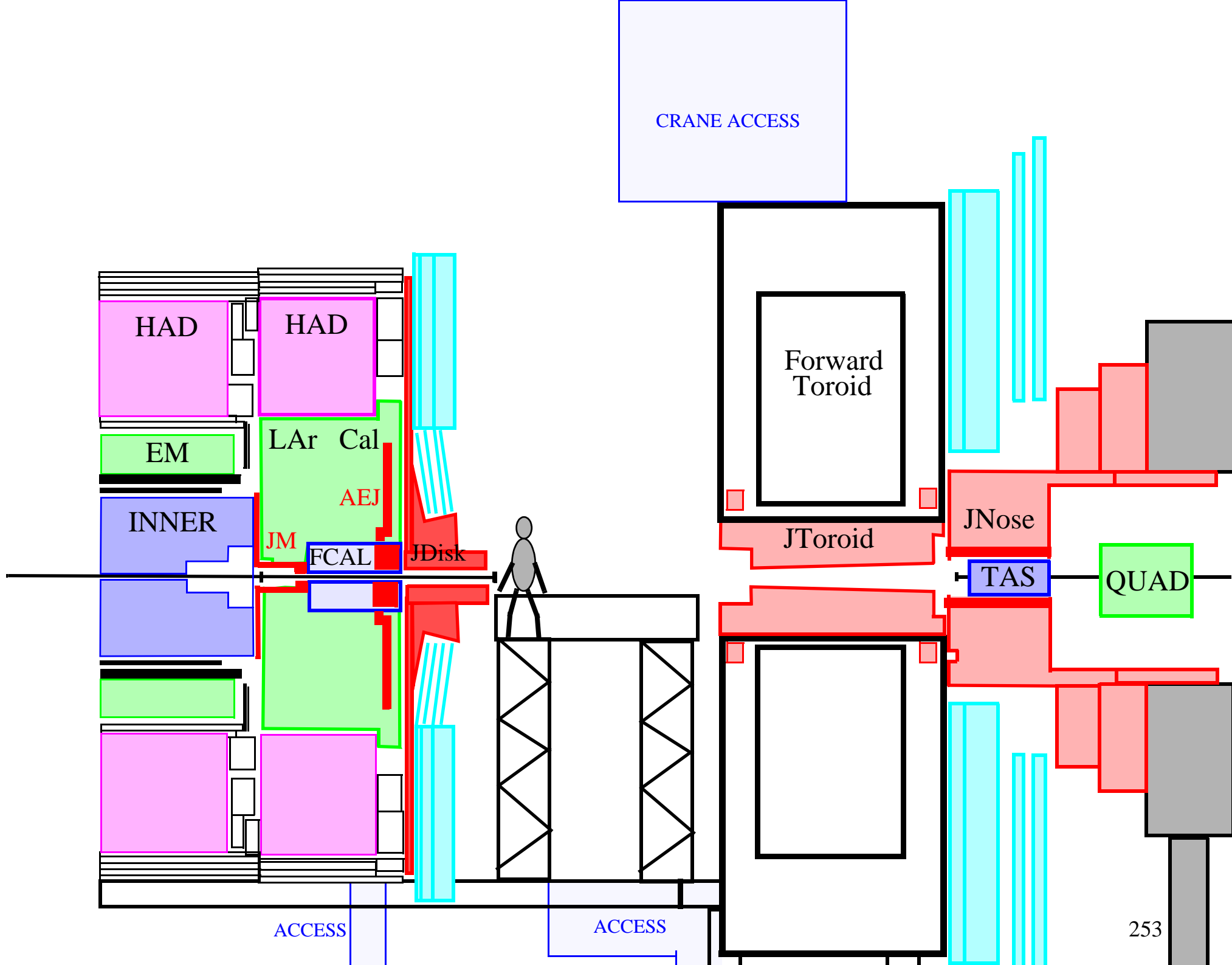

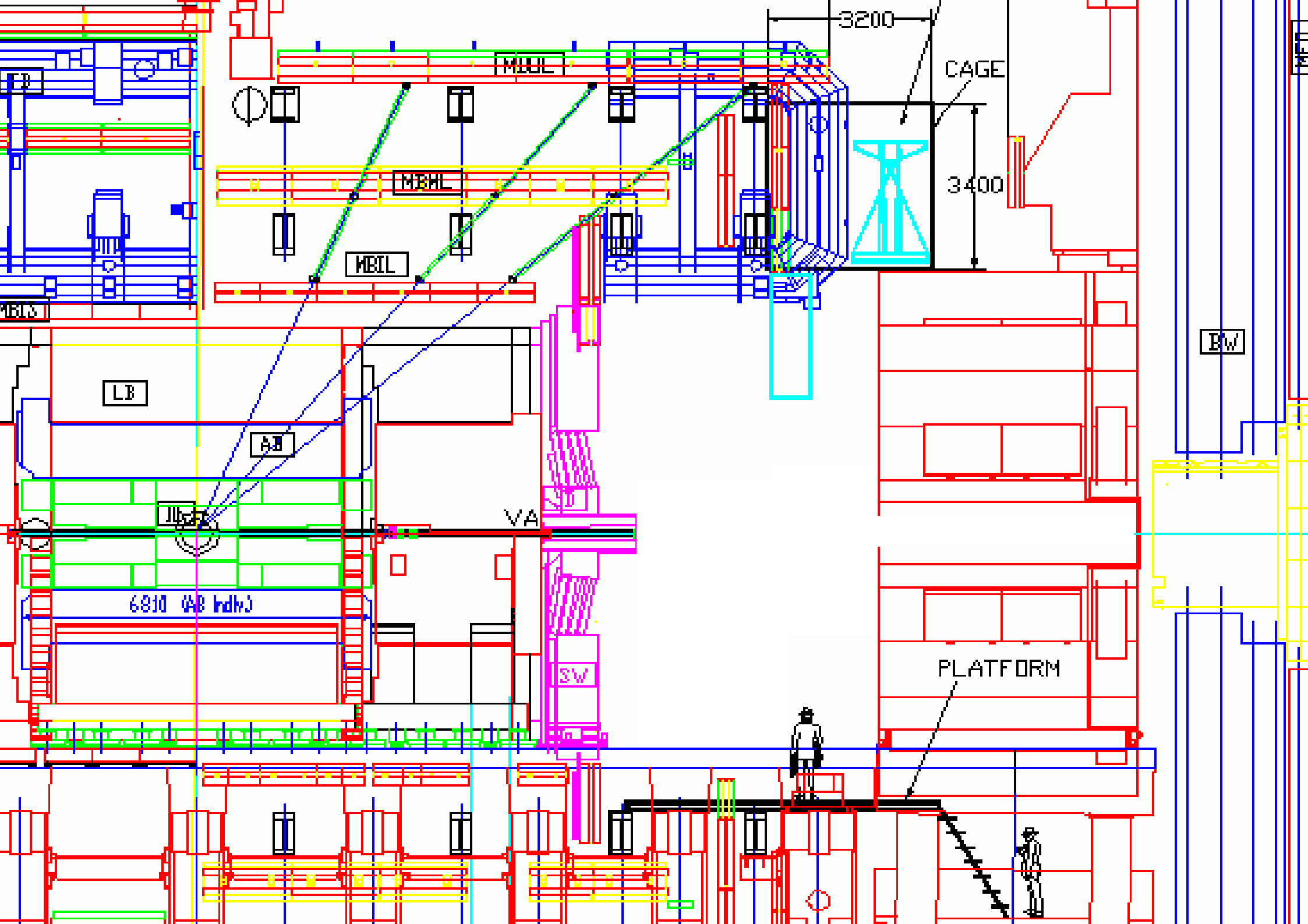

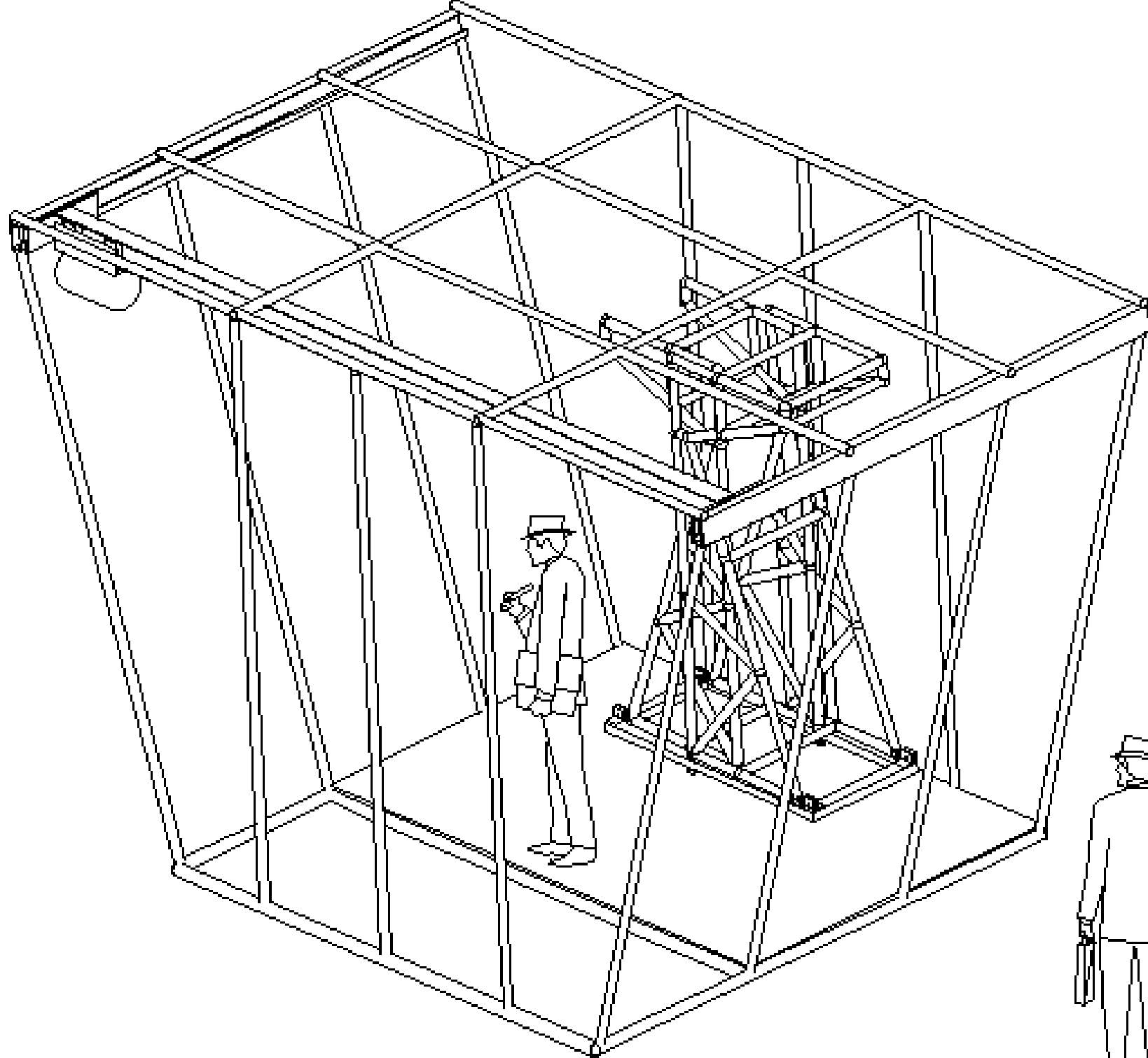

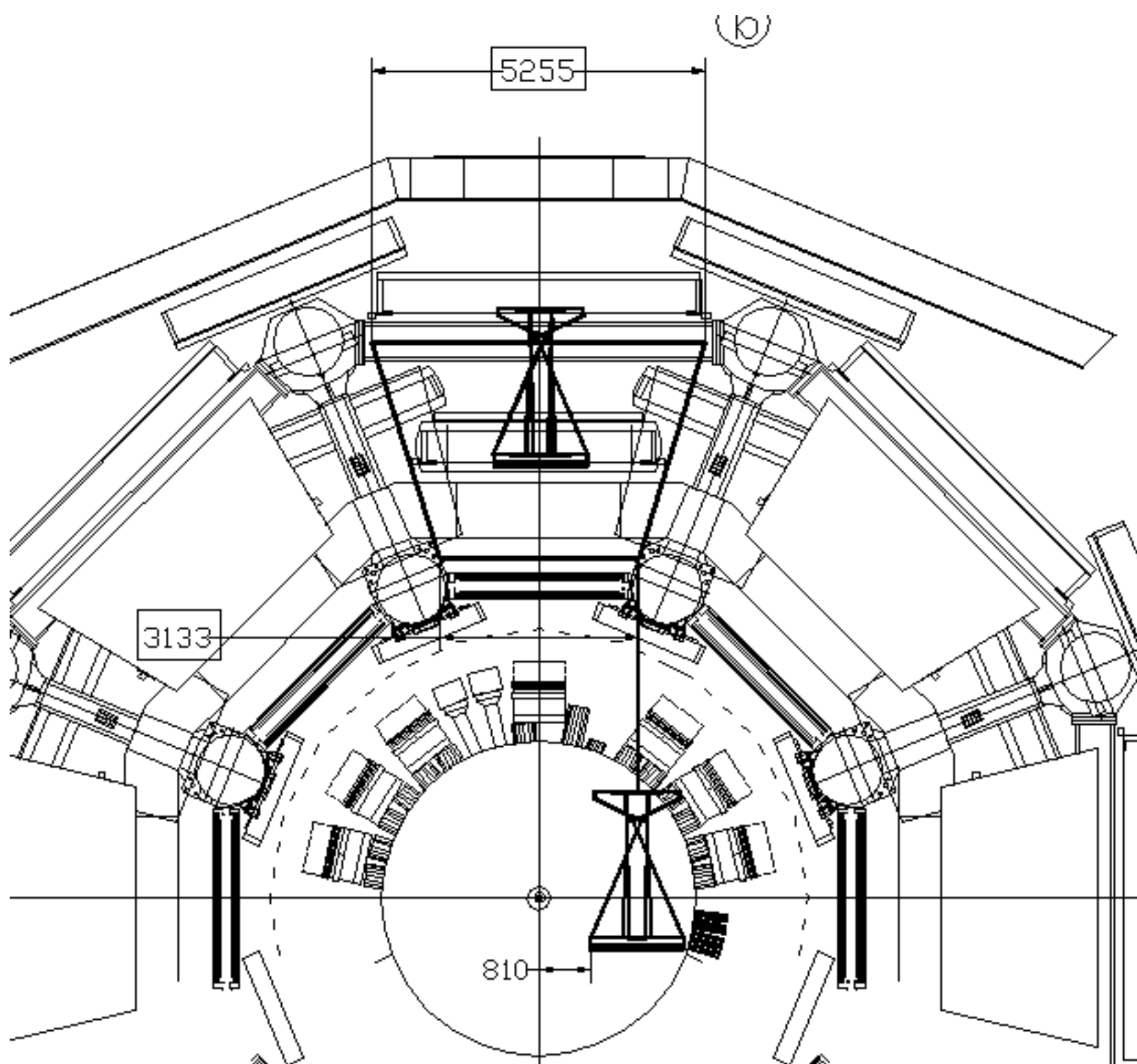

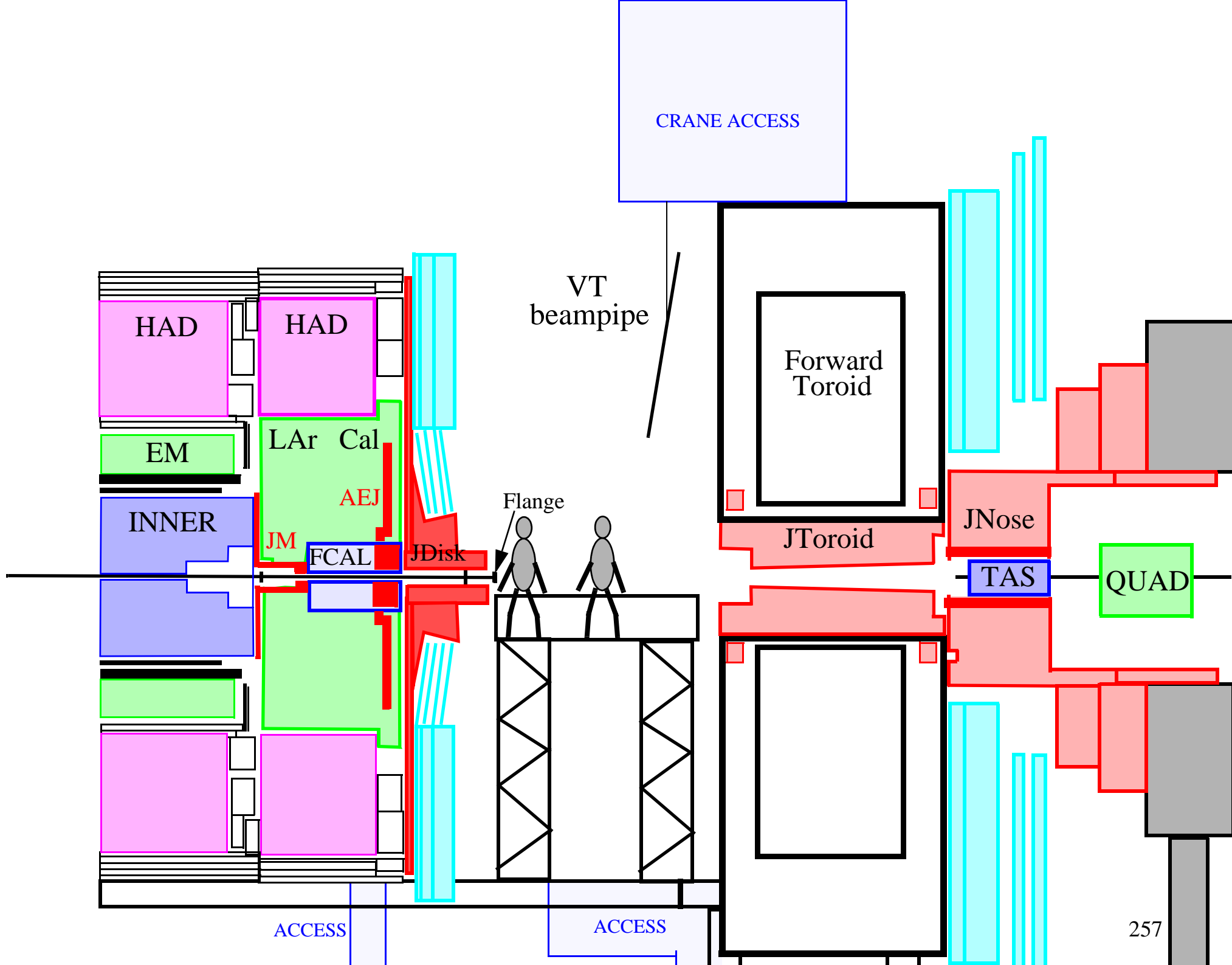

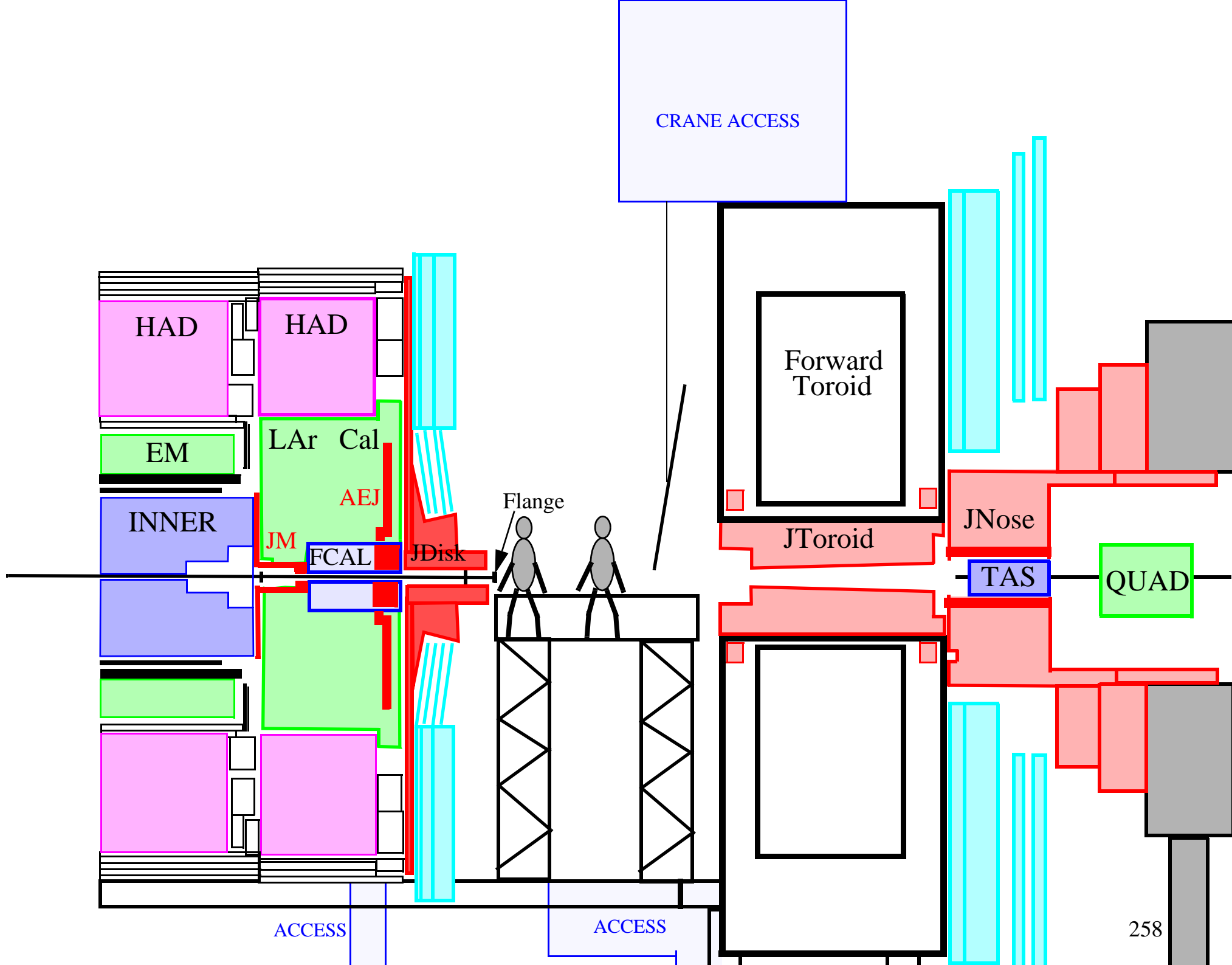

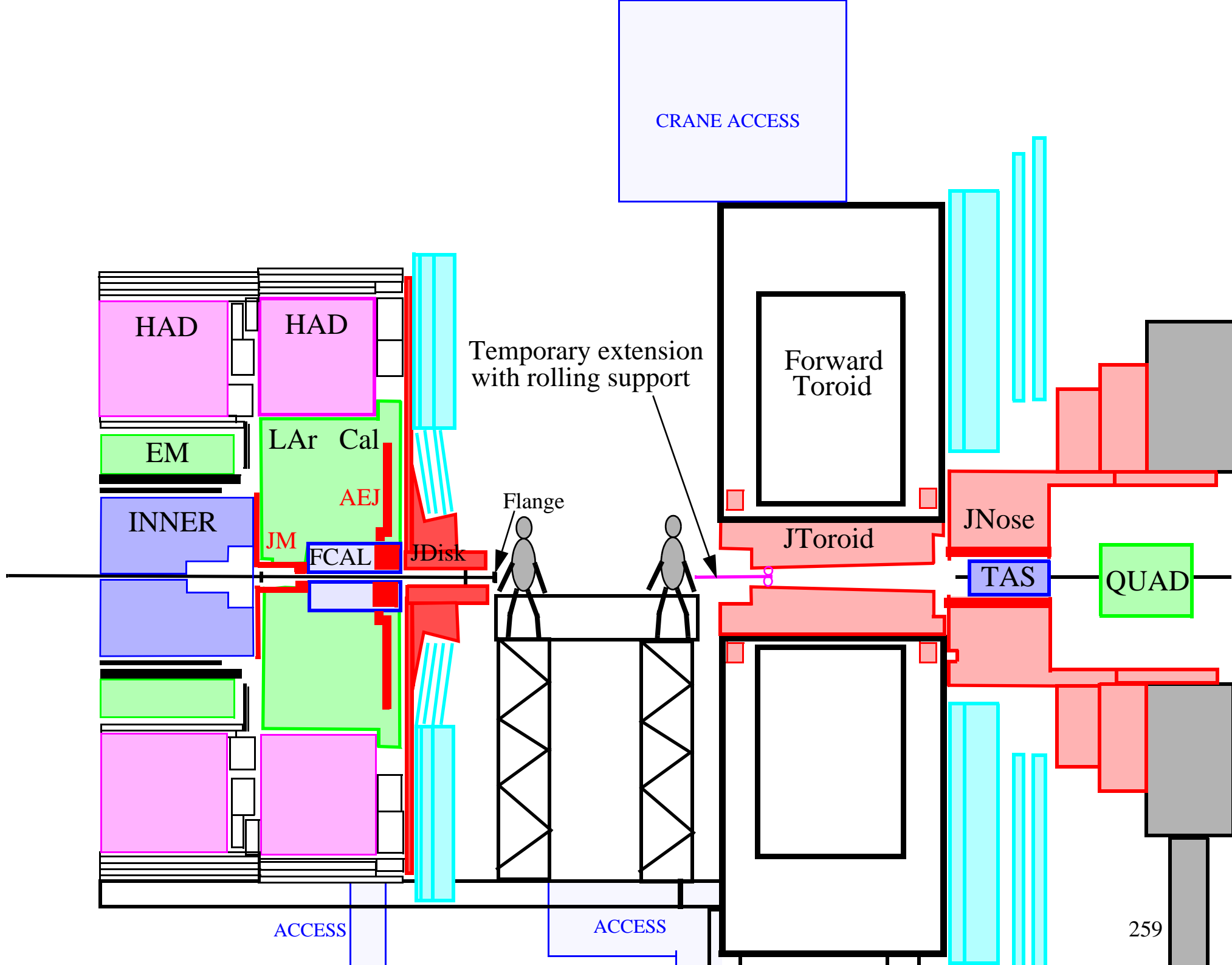

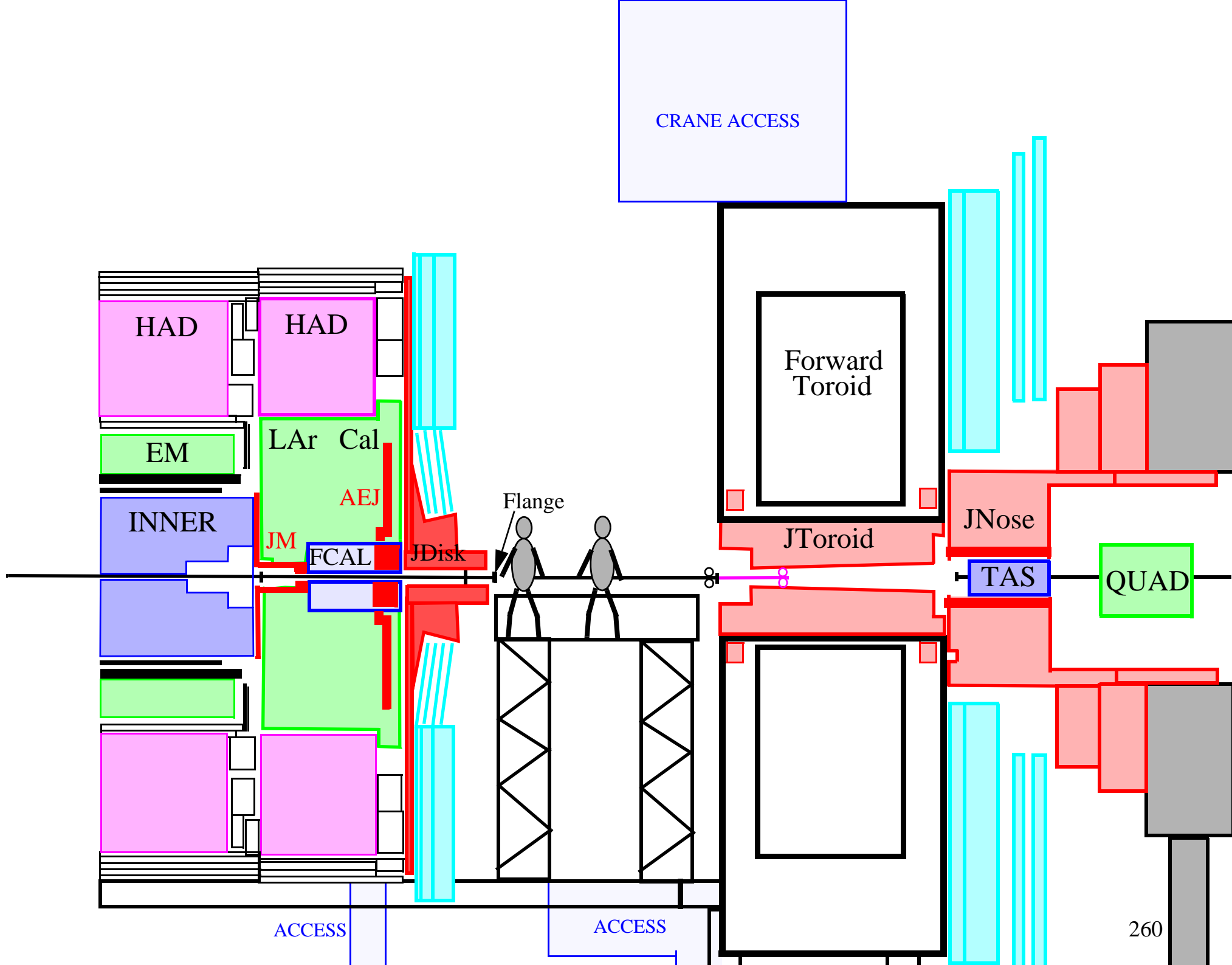

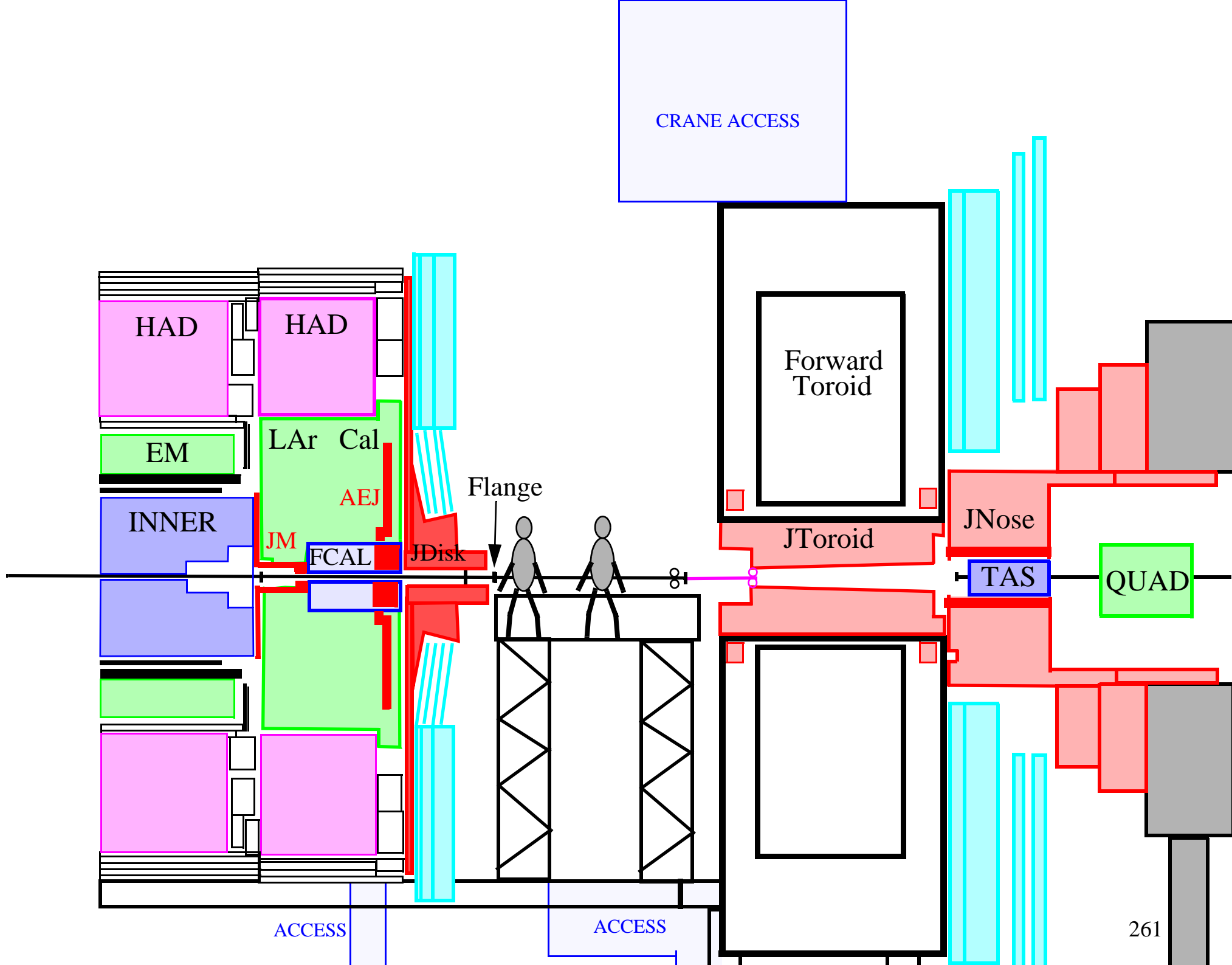

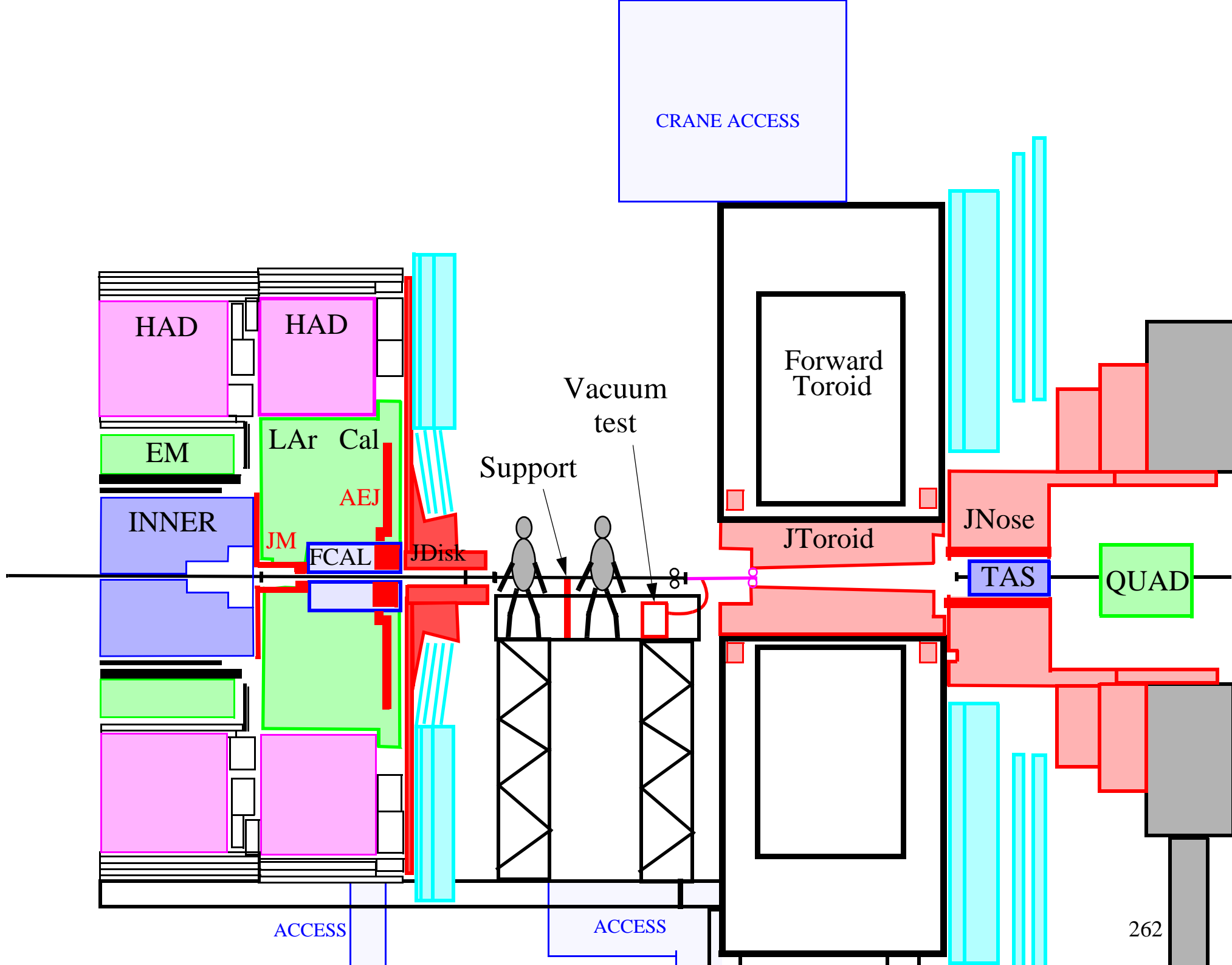

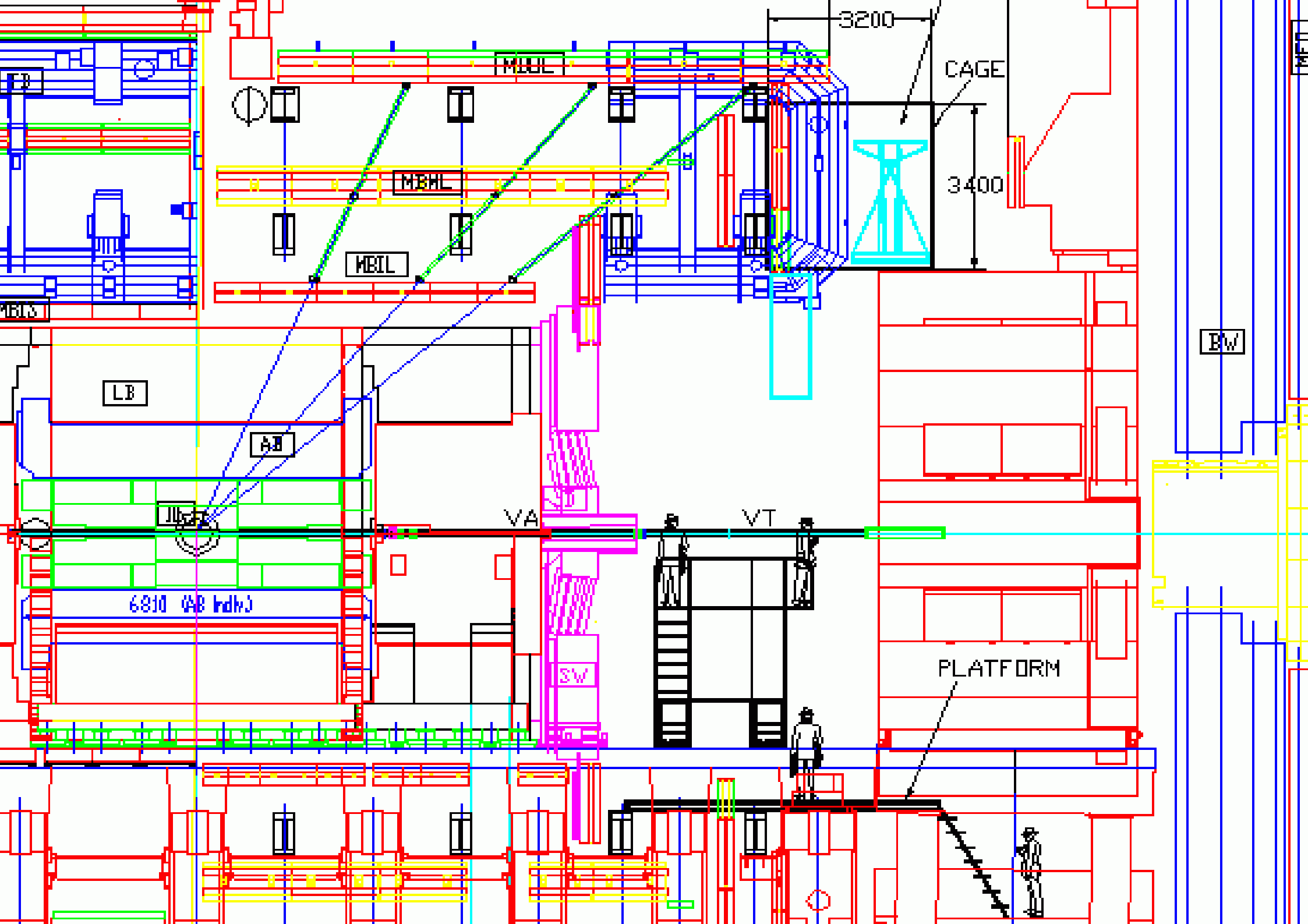

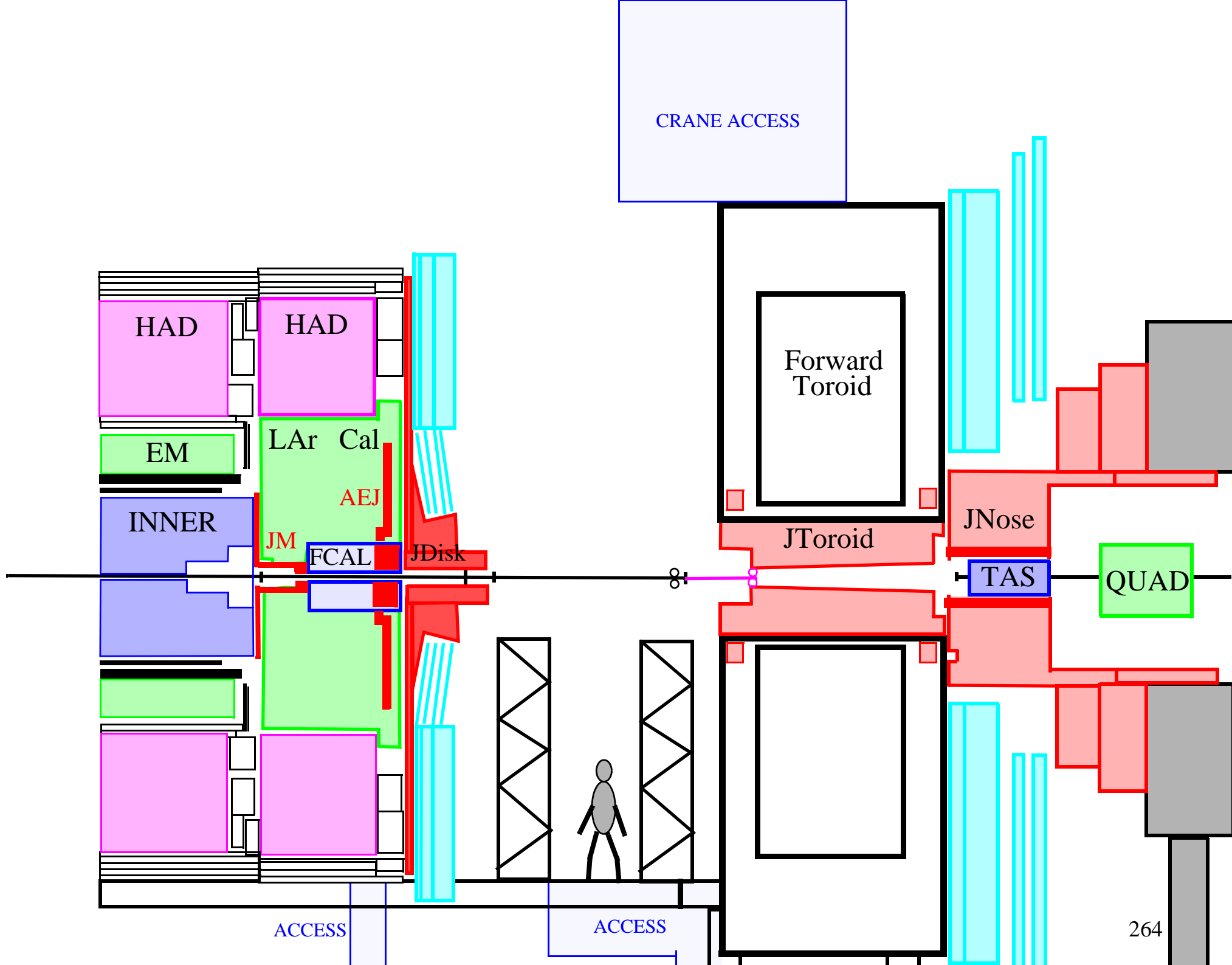

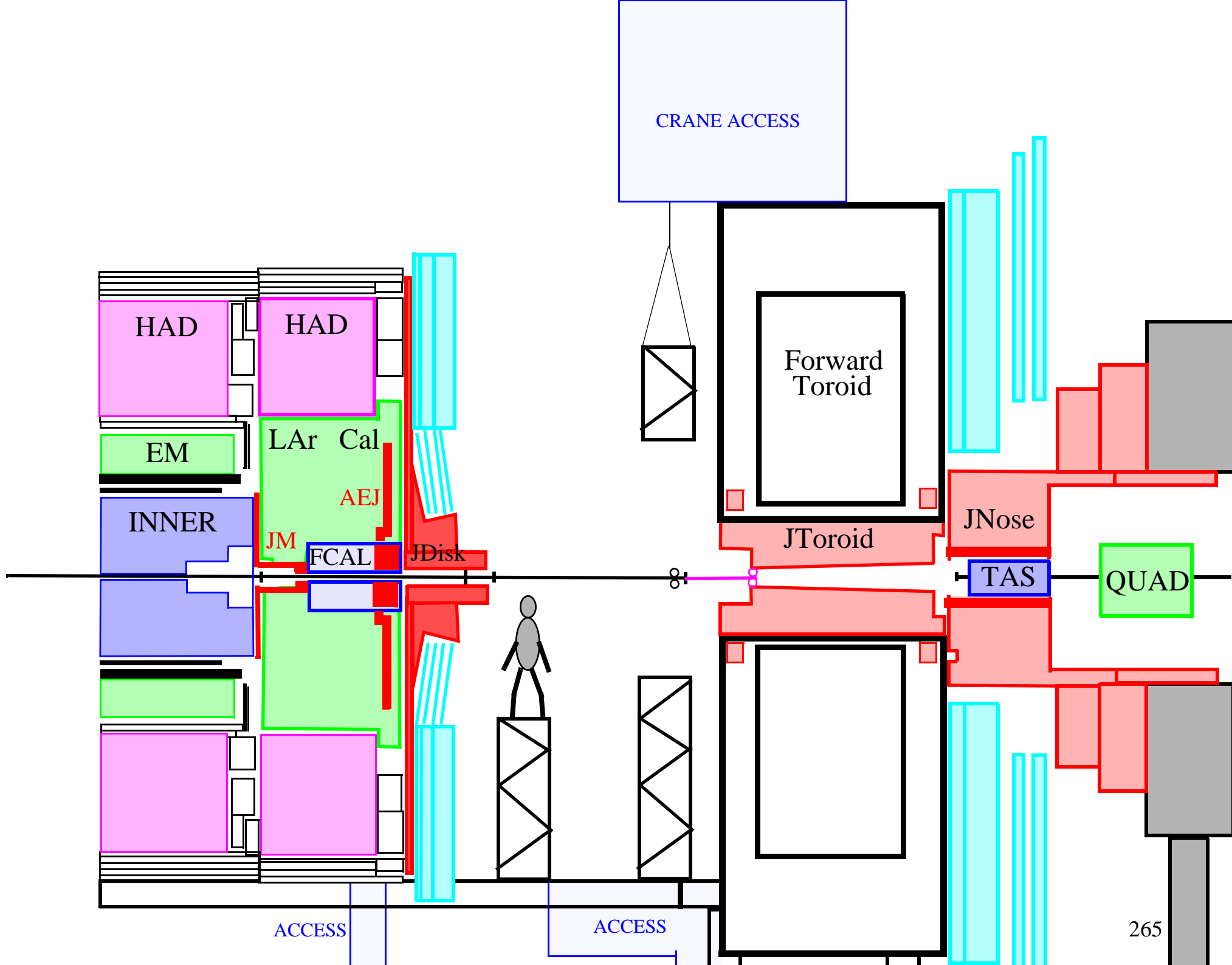

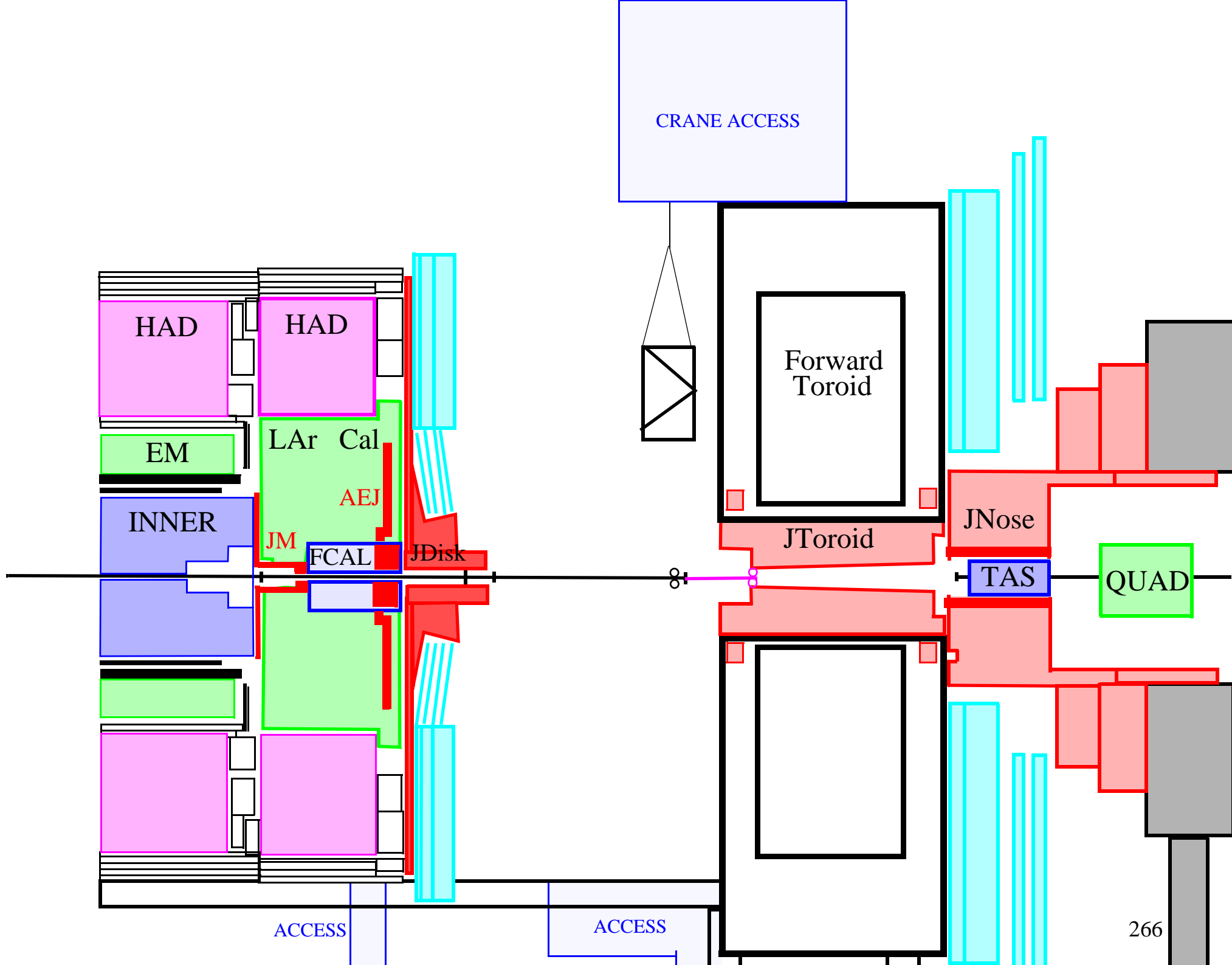

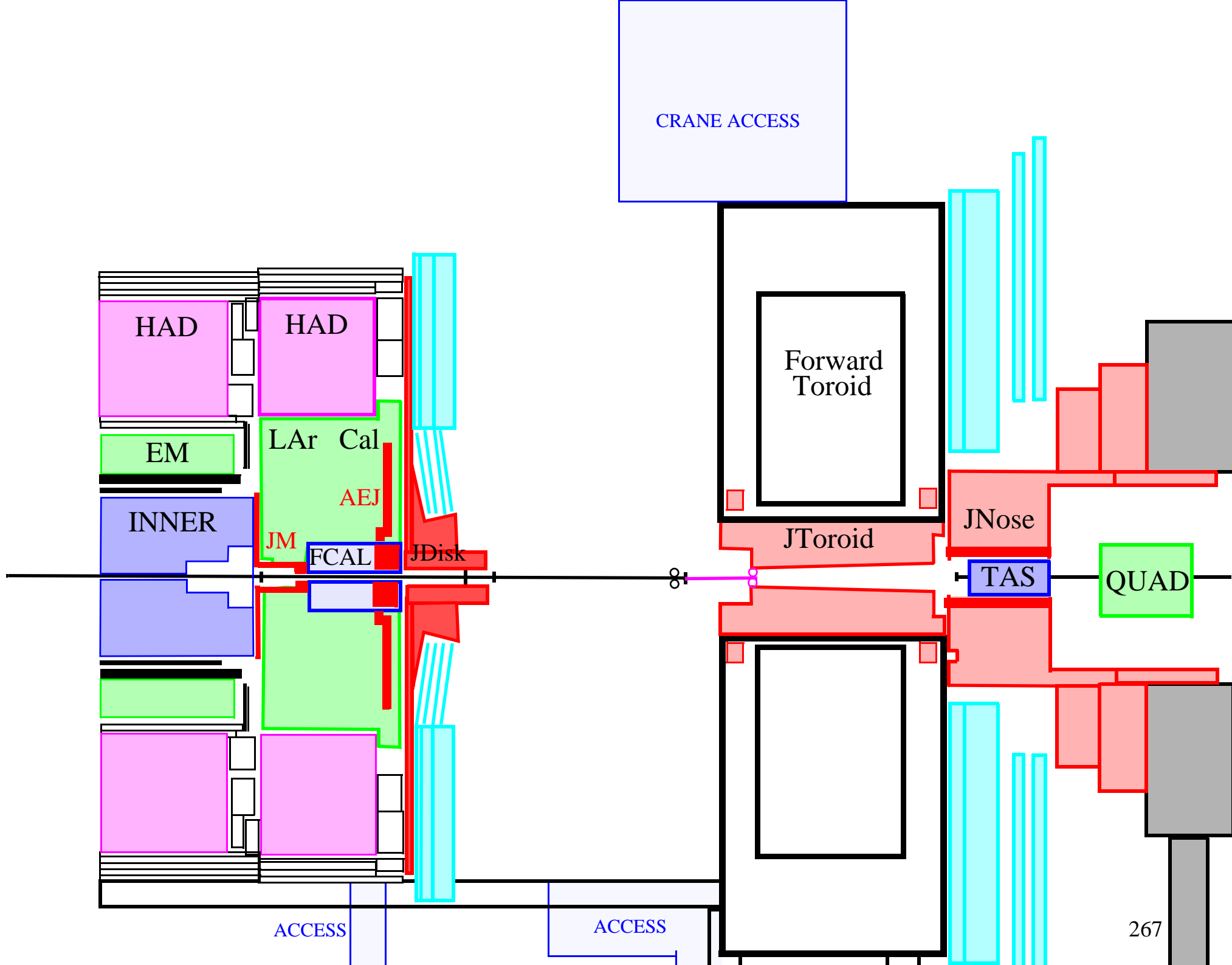

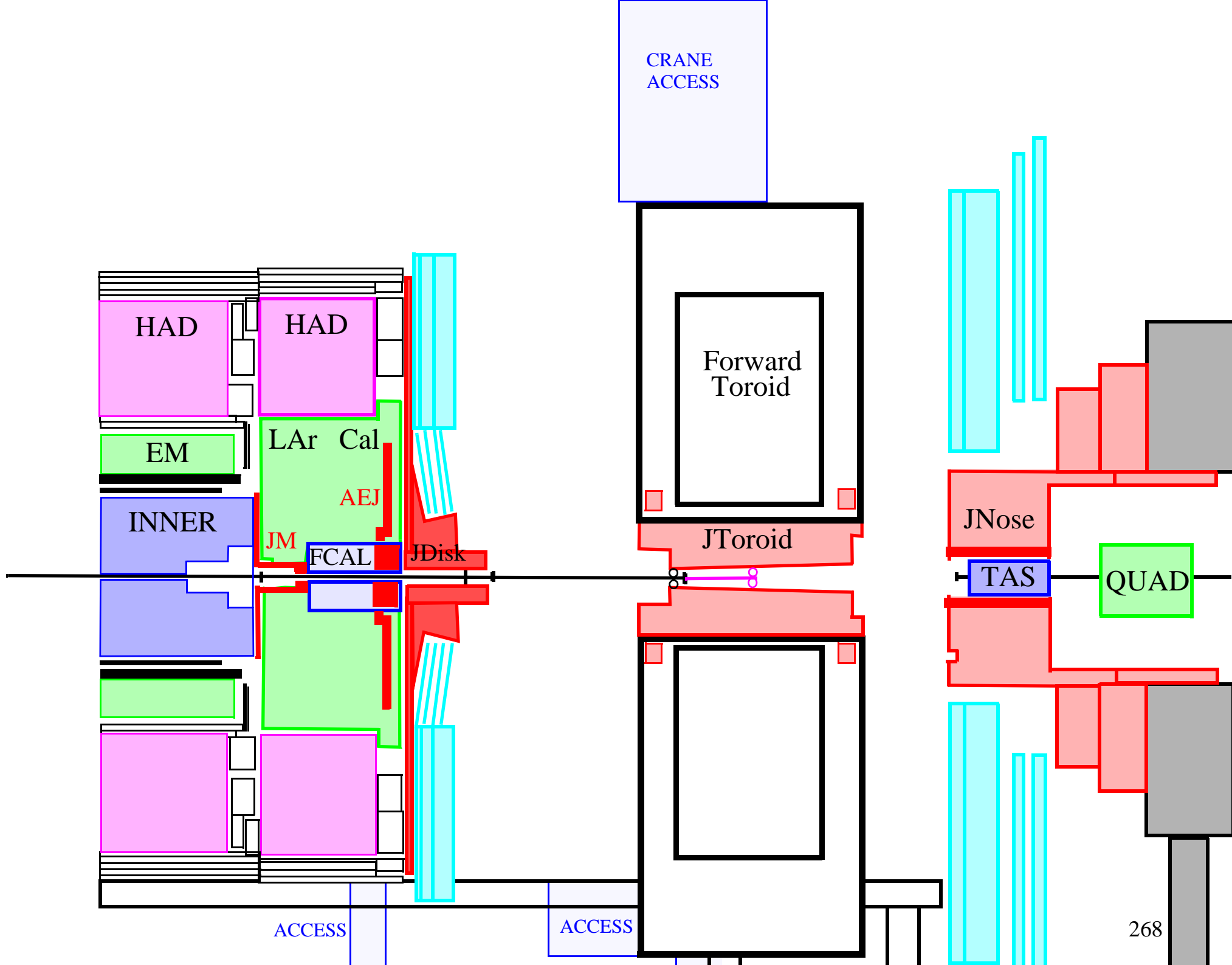

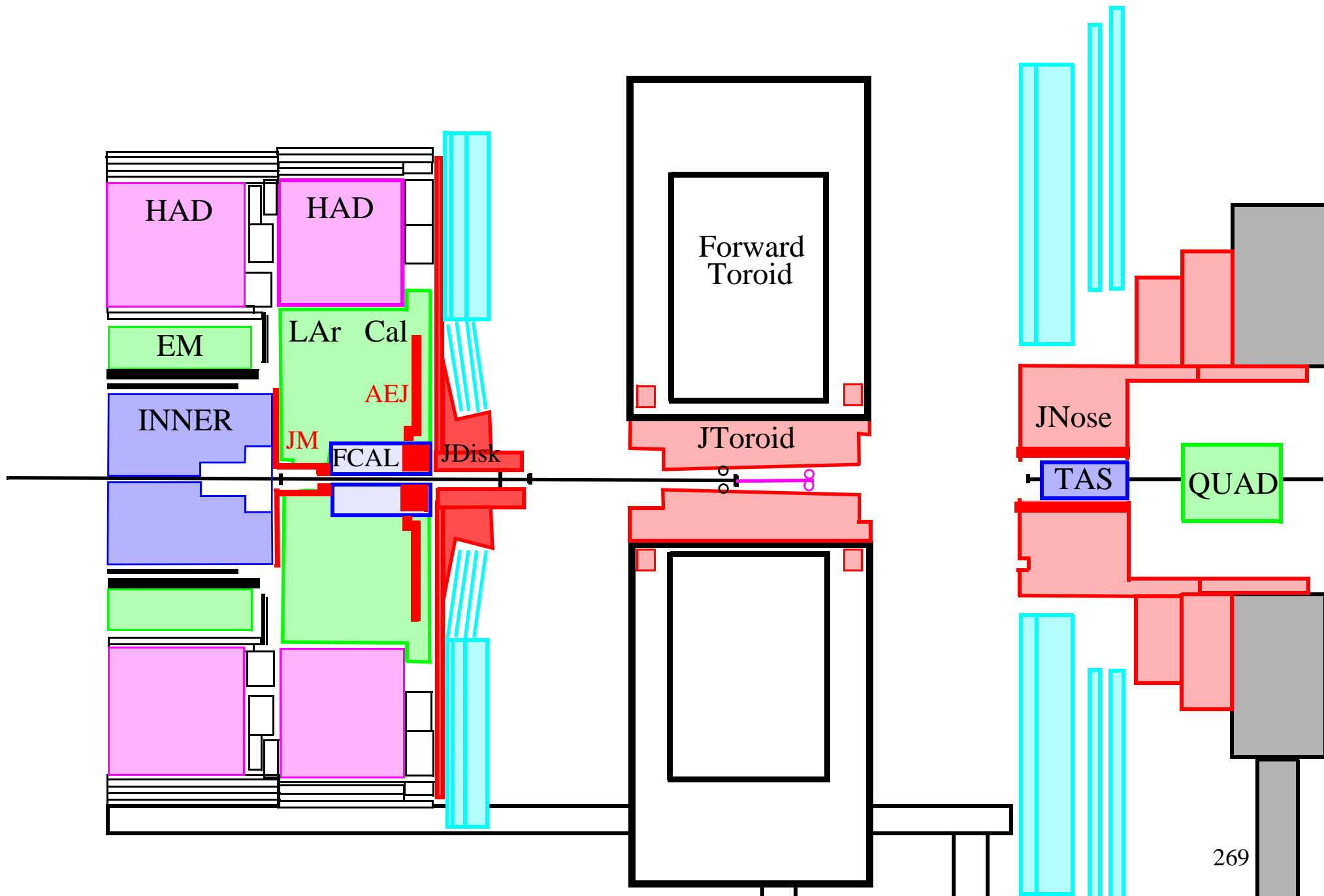

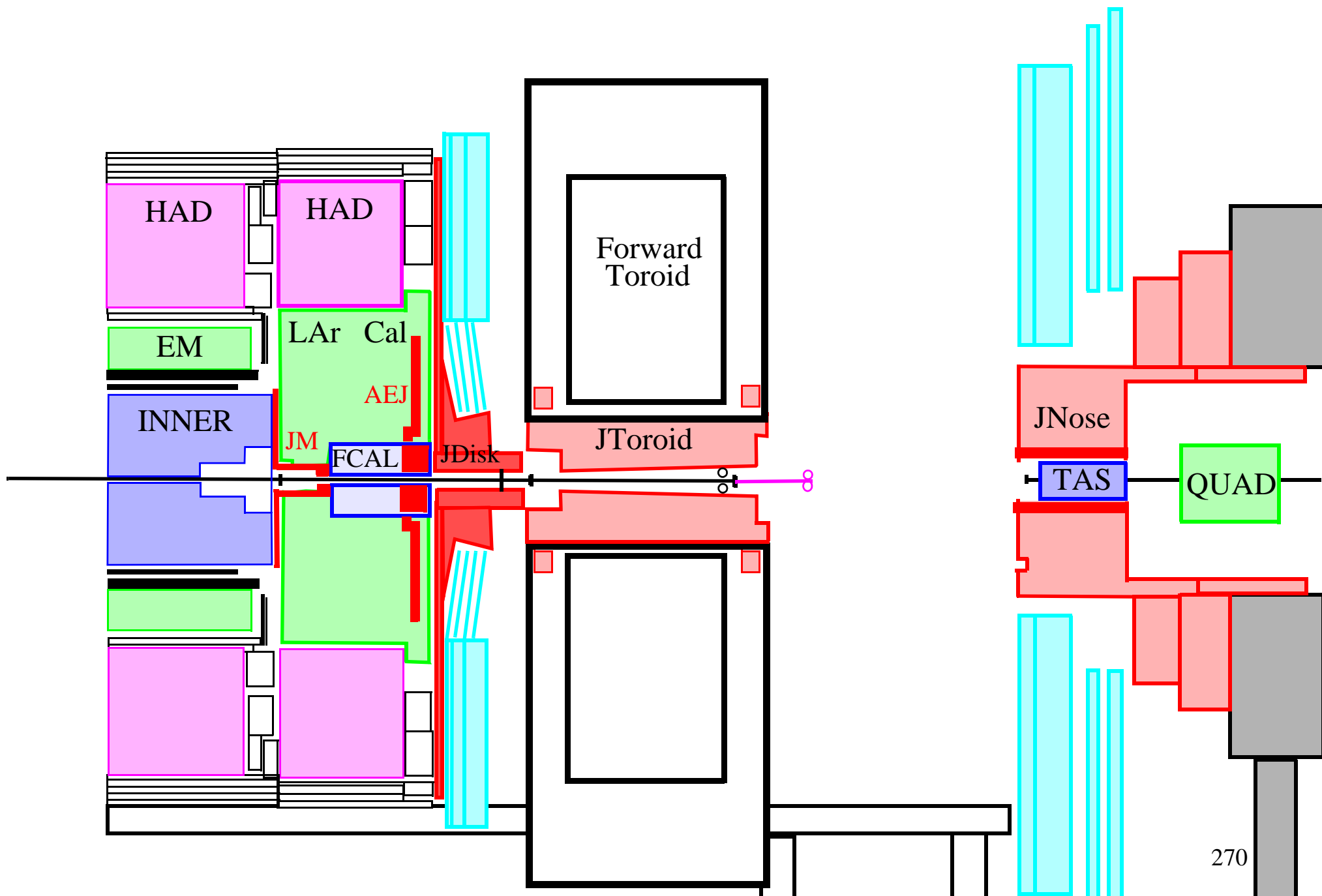

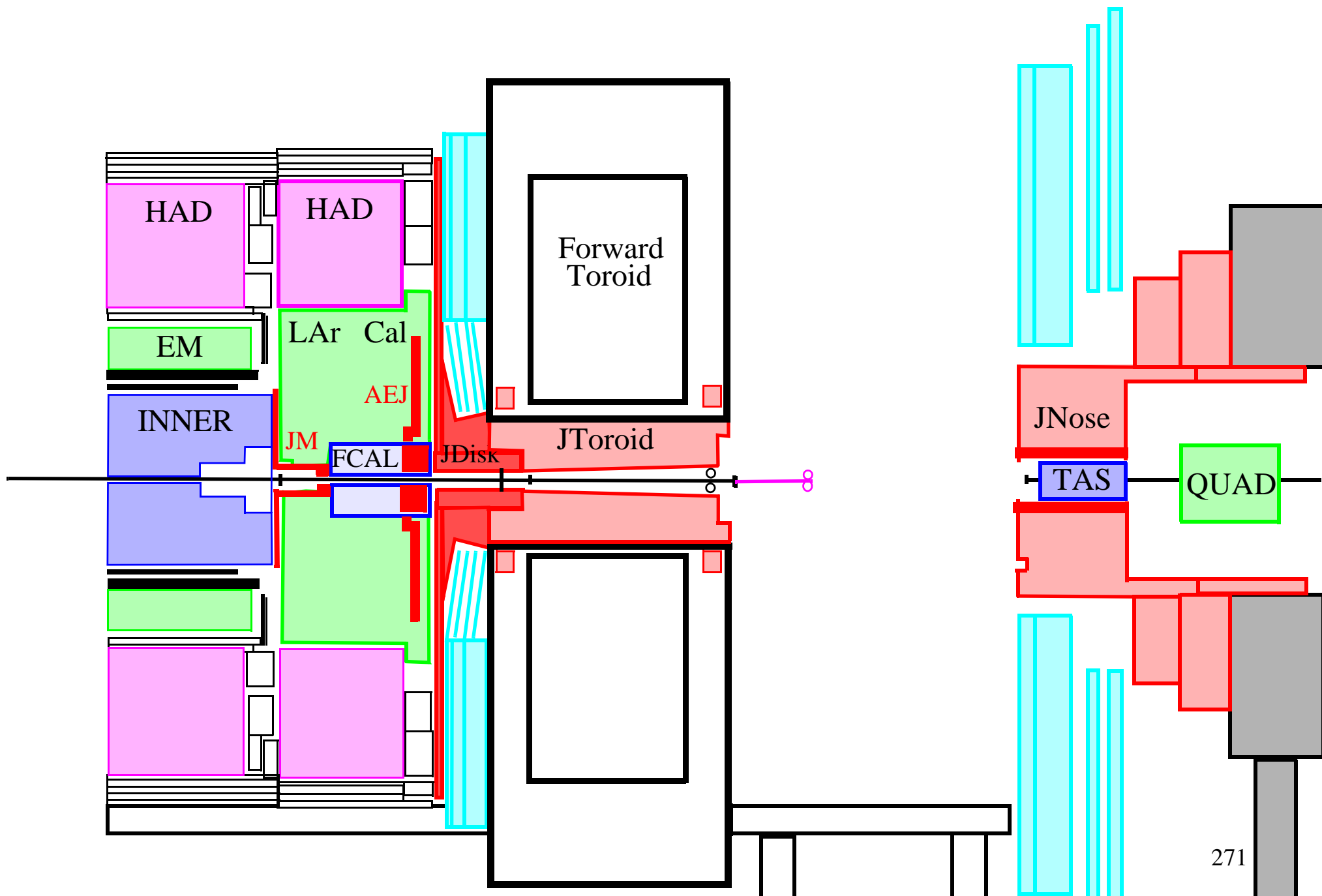

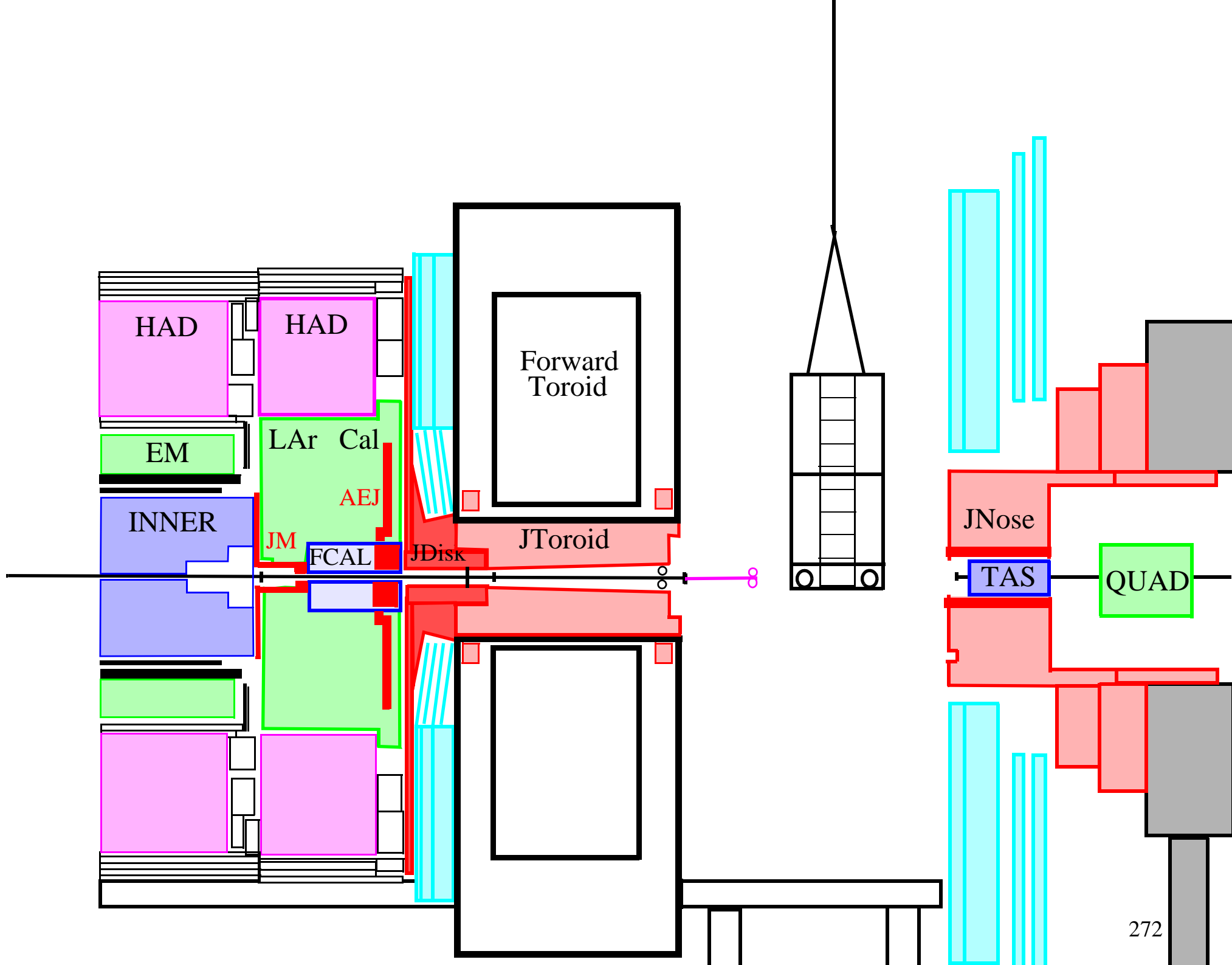

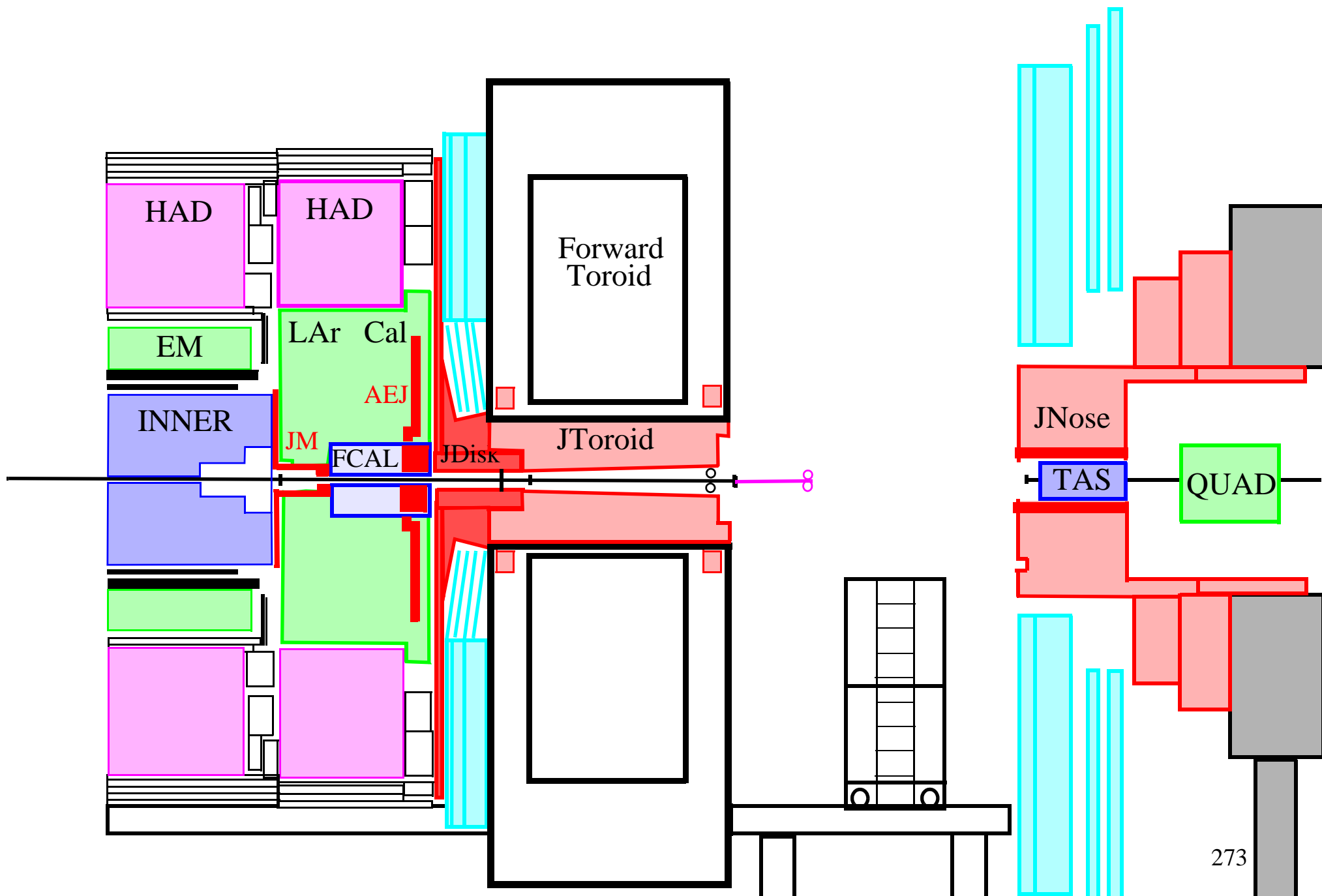

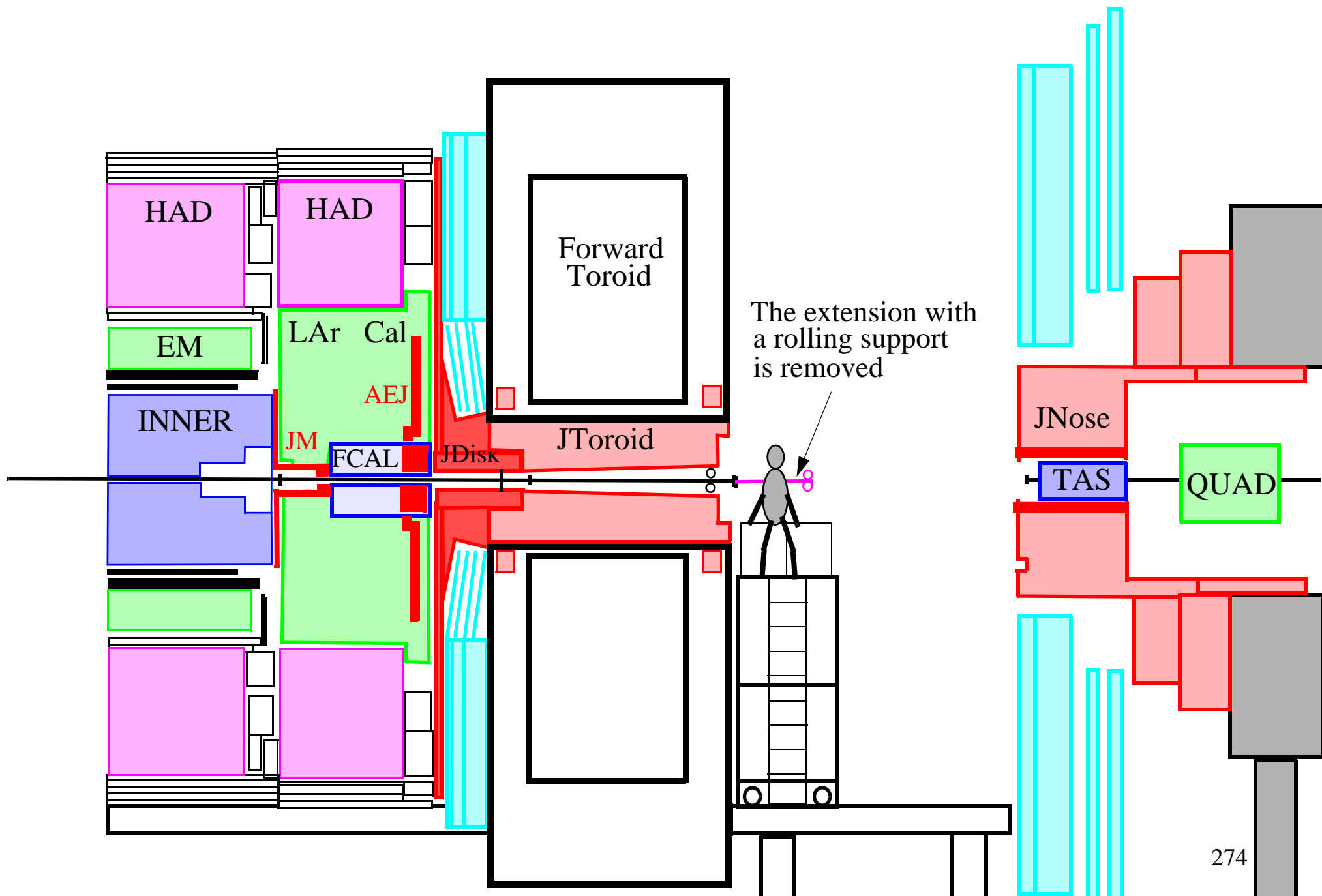

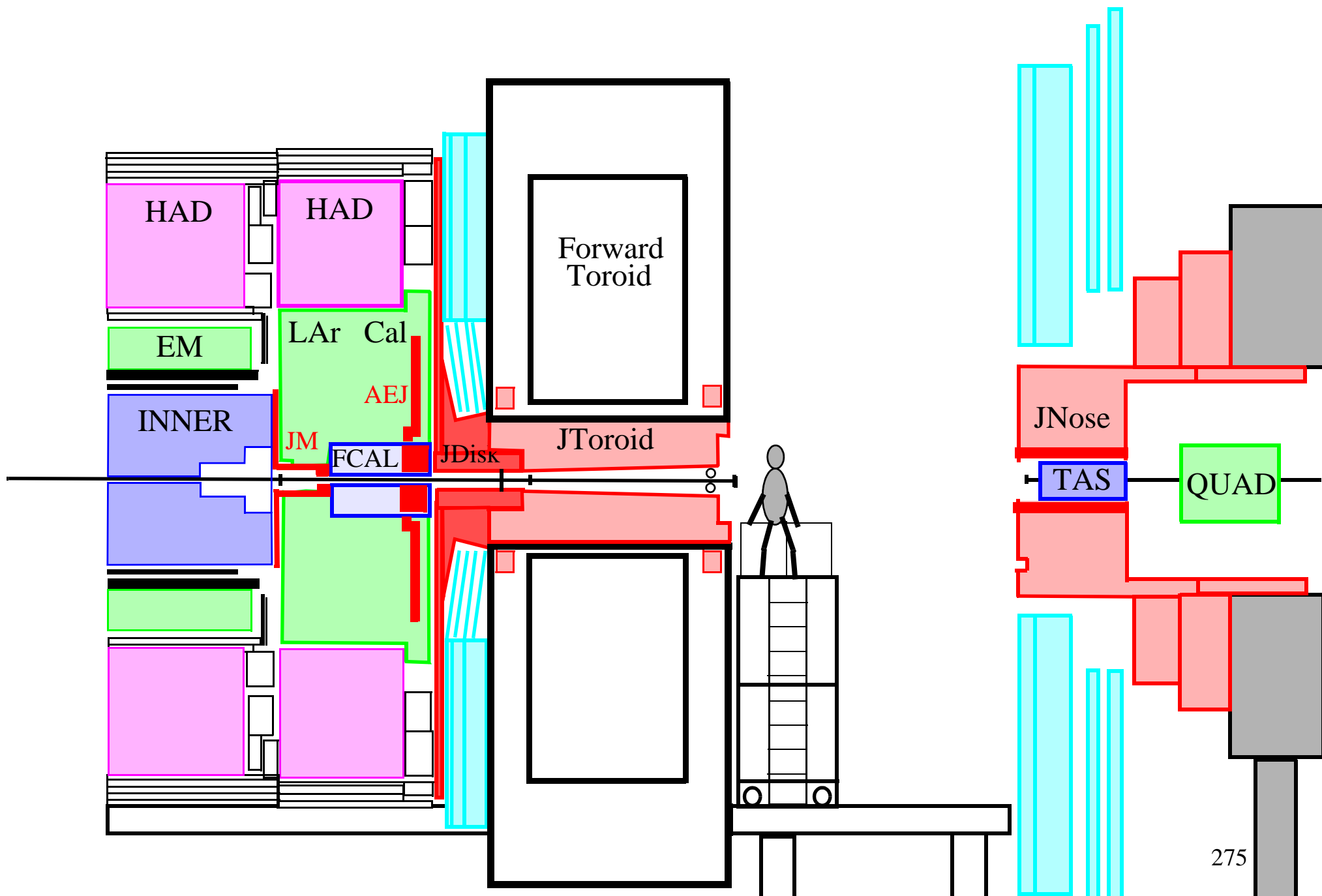

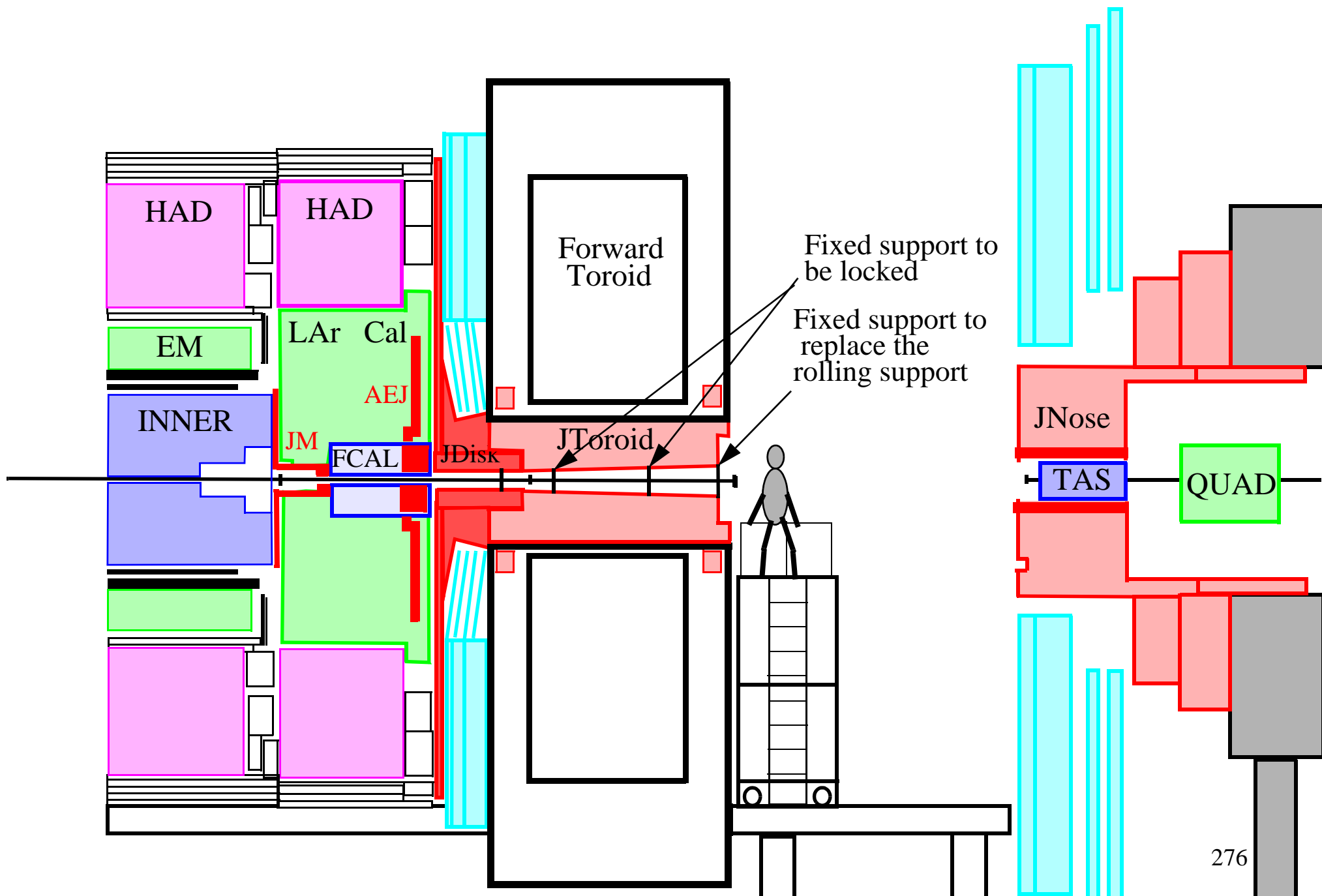

HAD

HAD

Forward
Toroid

EM

LAr Cal

AEJ

INNER

JM

FCAL

JDisk

JToroid

Fixed support to
be locked

Fixed support to
replace the
rolling support

JNose

TAS

QUAD

Beampipe supports

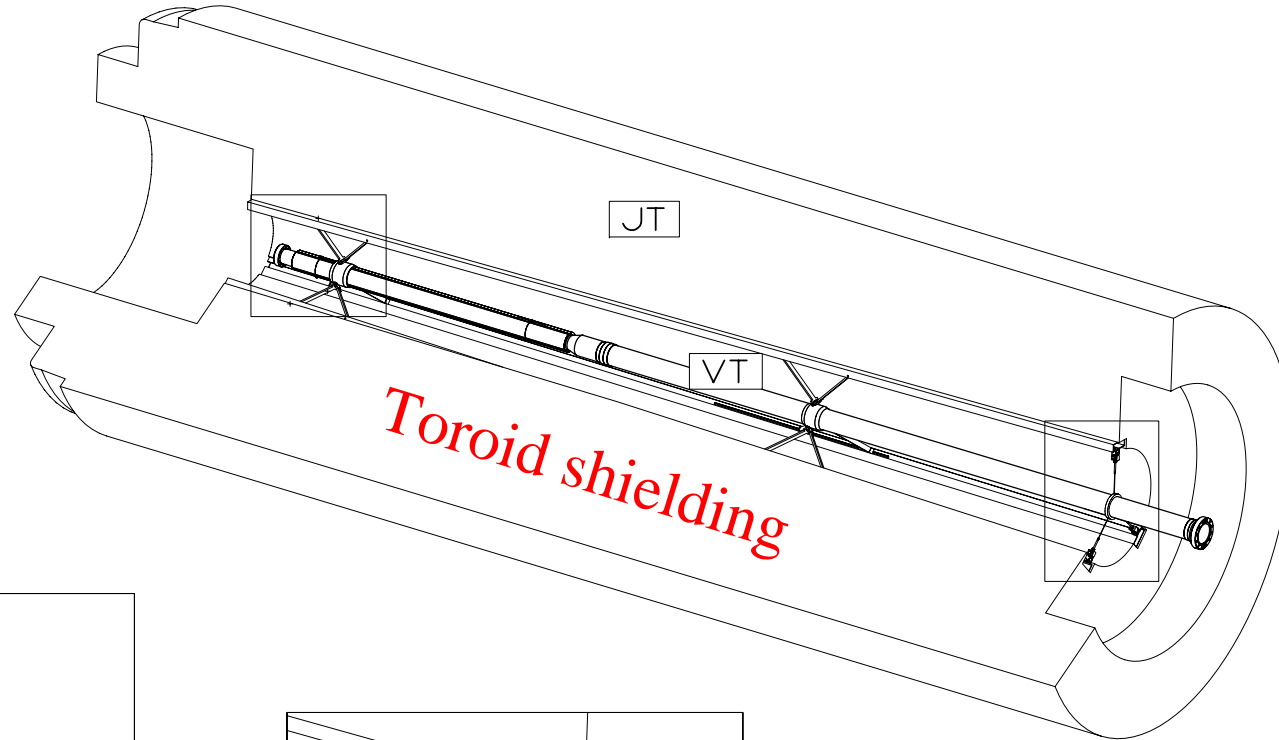

This support has to be locked.

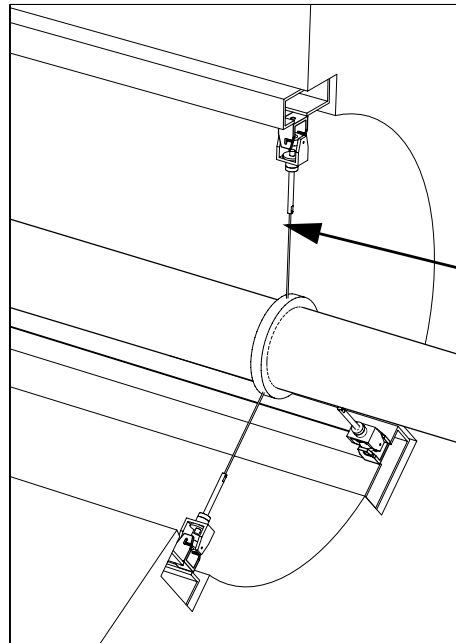
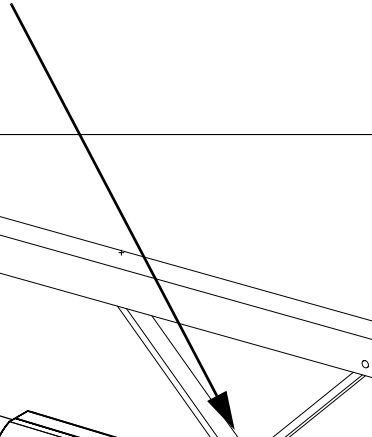

This support has to be attached and the rolling support has to be removed.

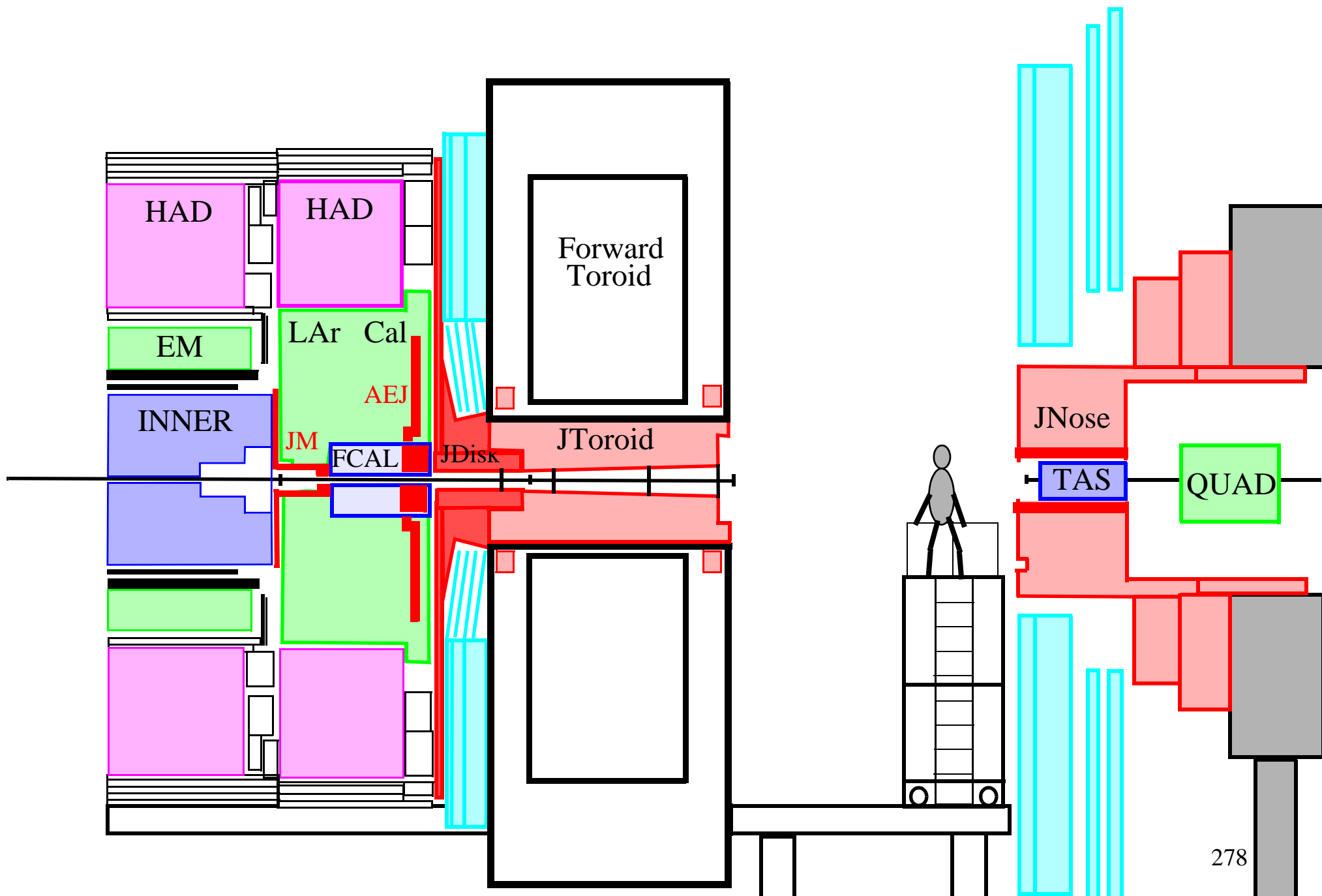

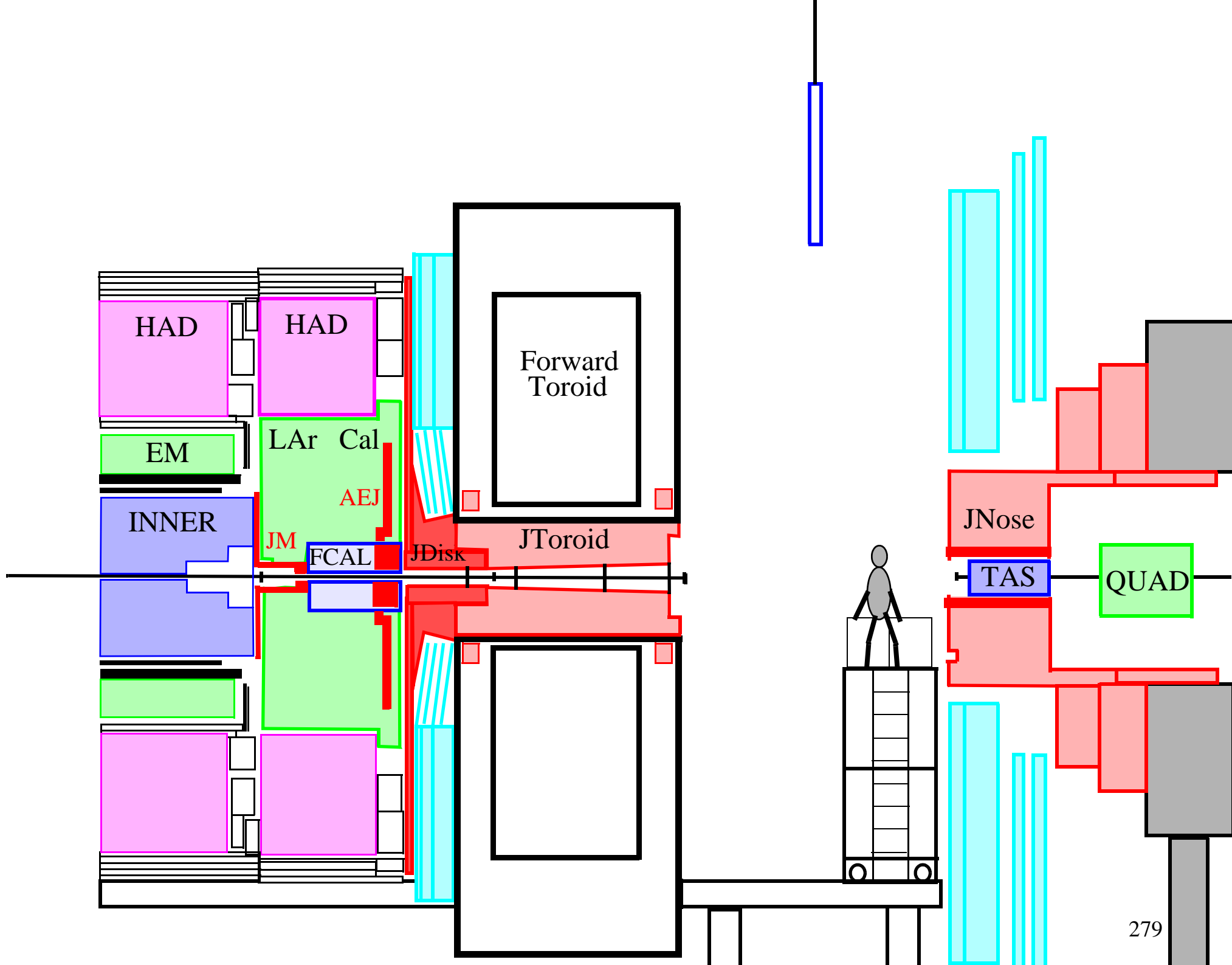

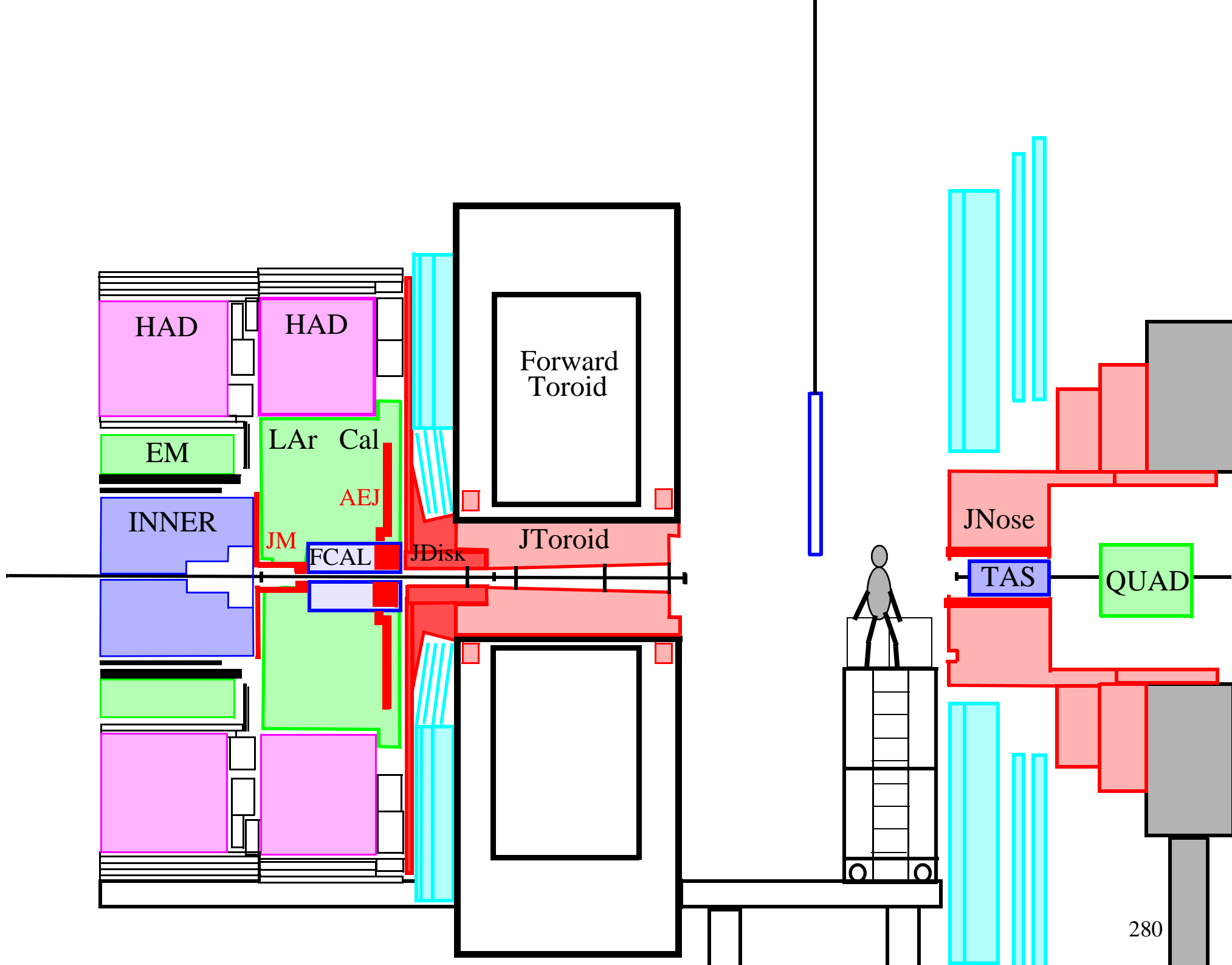

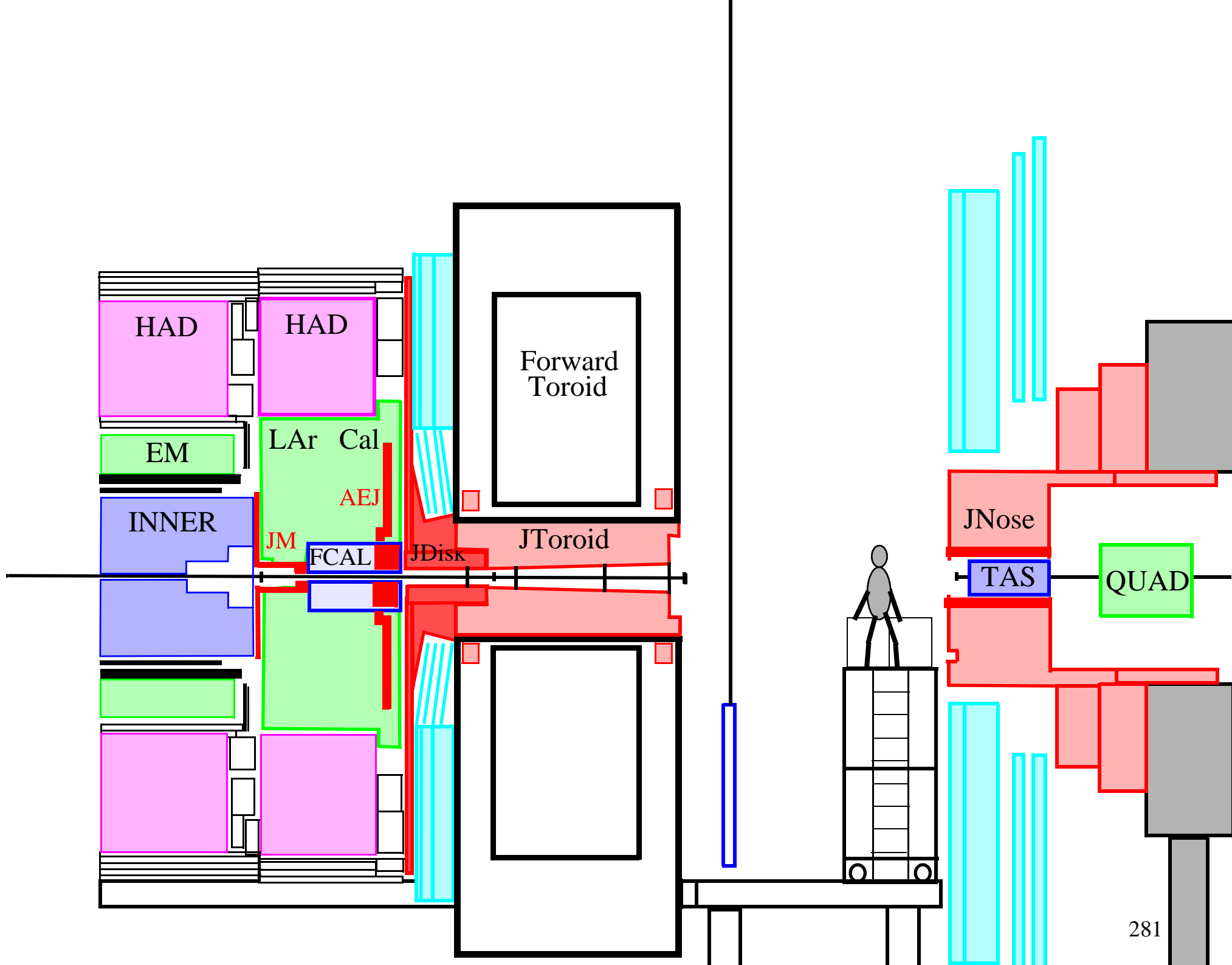

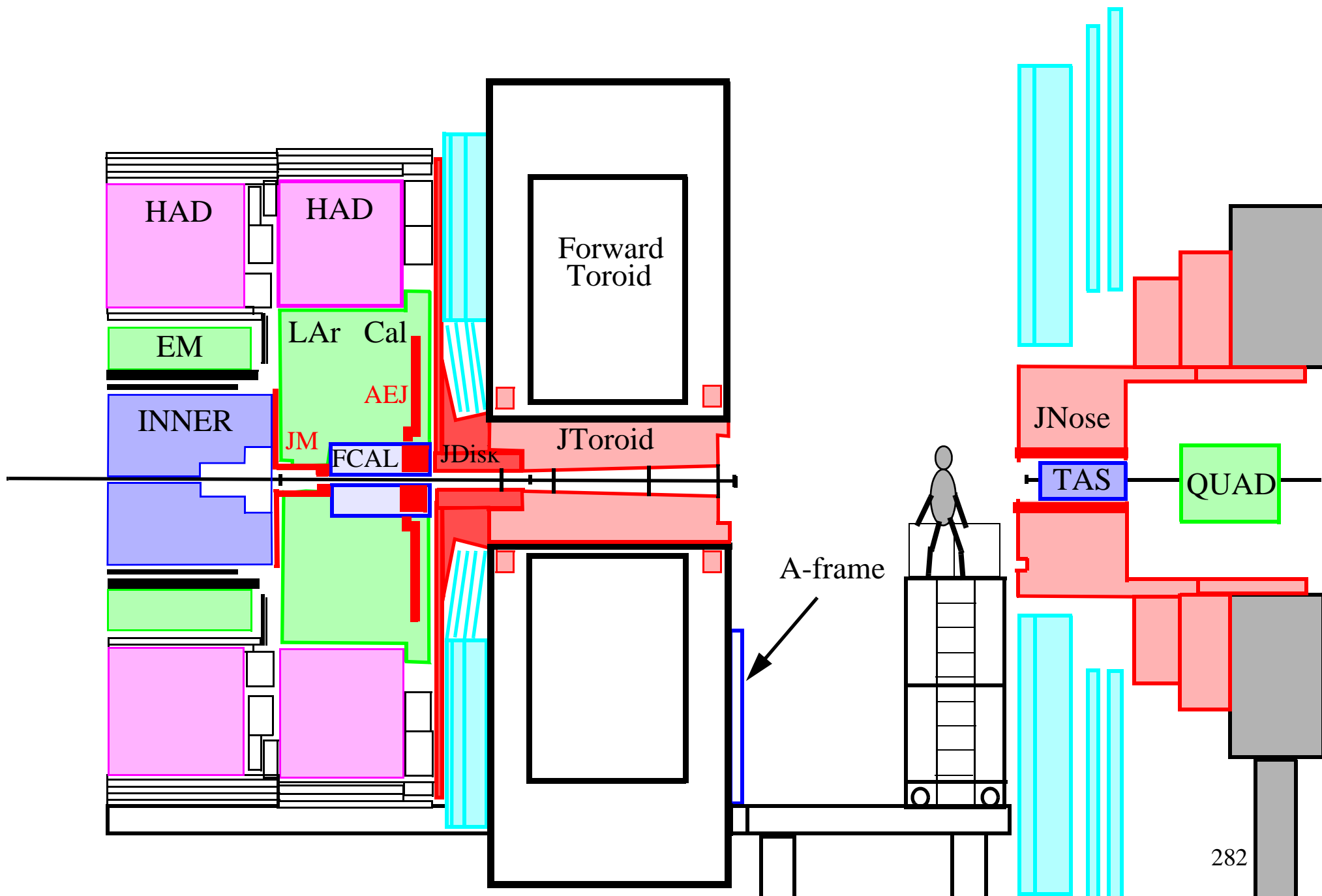

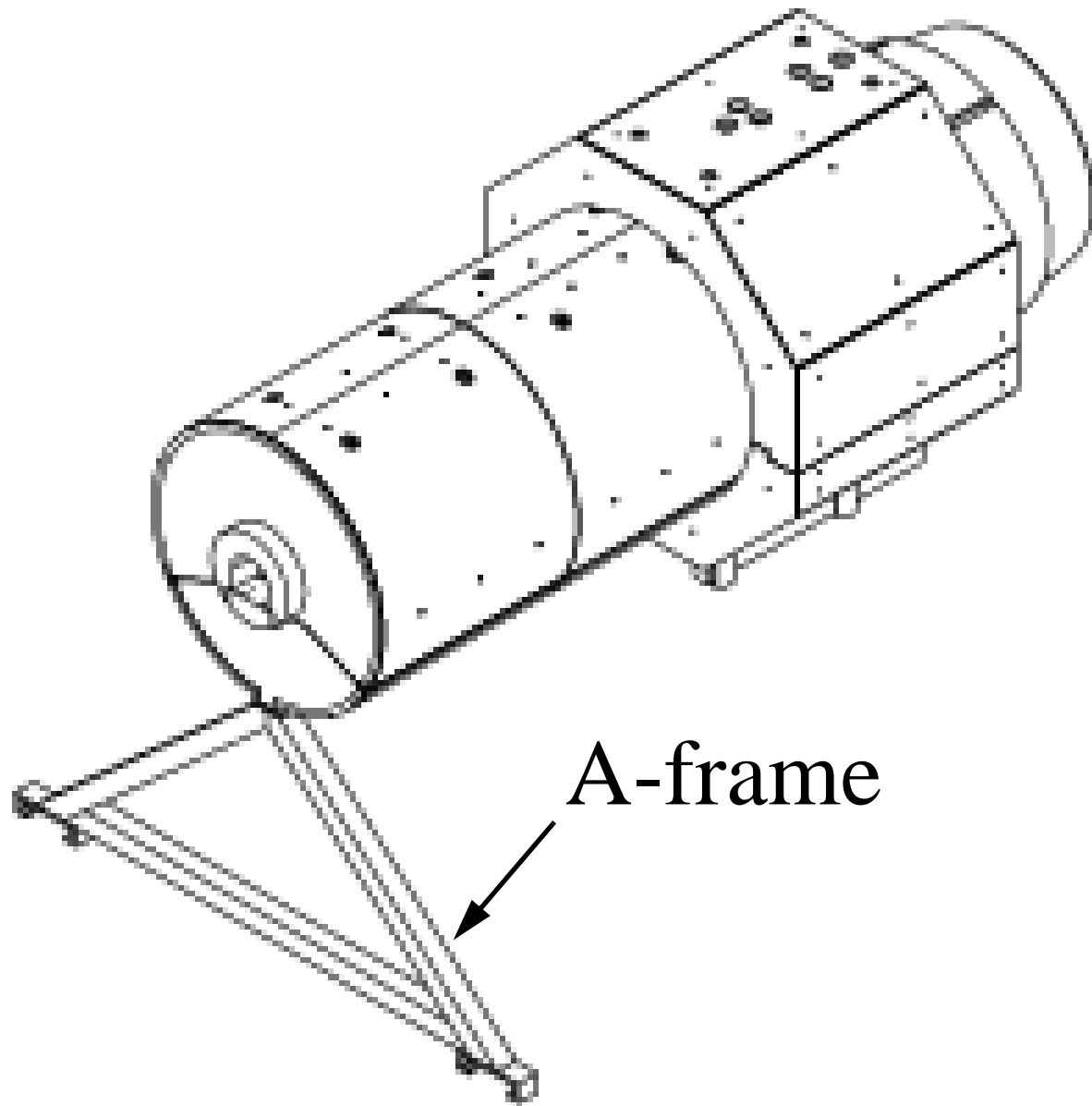

A-frame

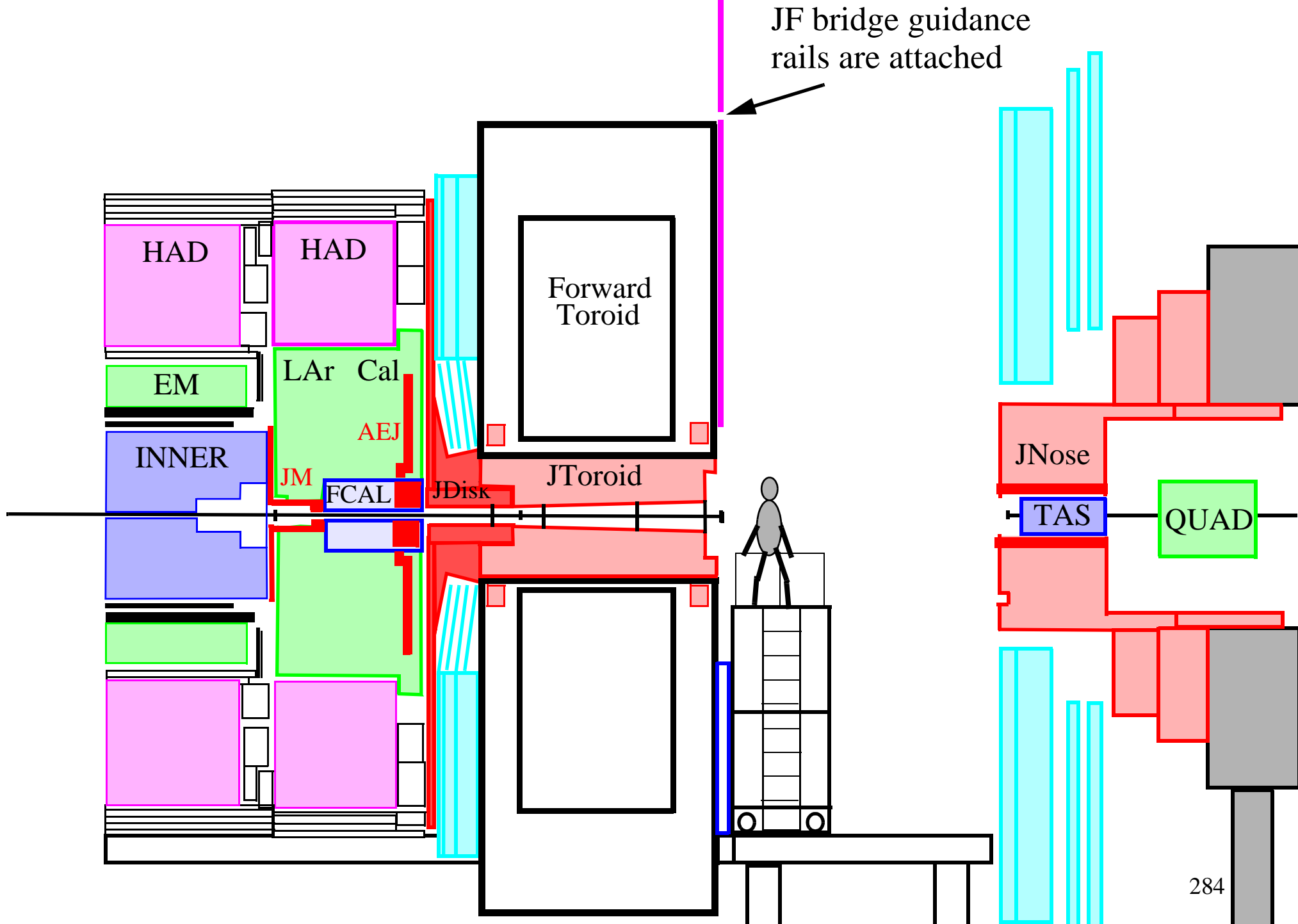

JF bridge guidance rails are attached

JF bridge guidance rails are attached to the rails above the toroid.

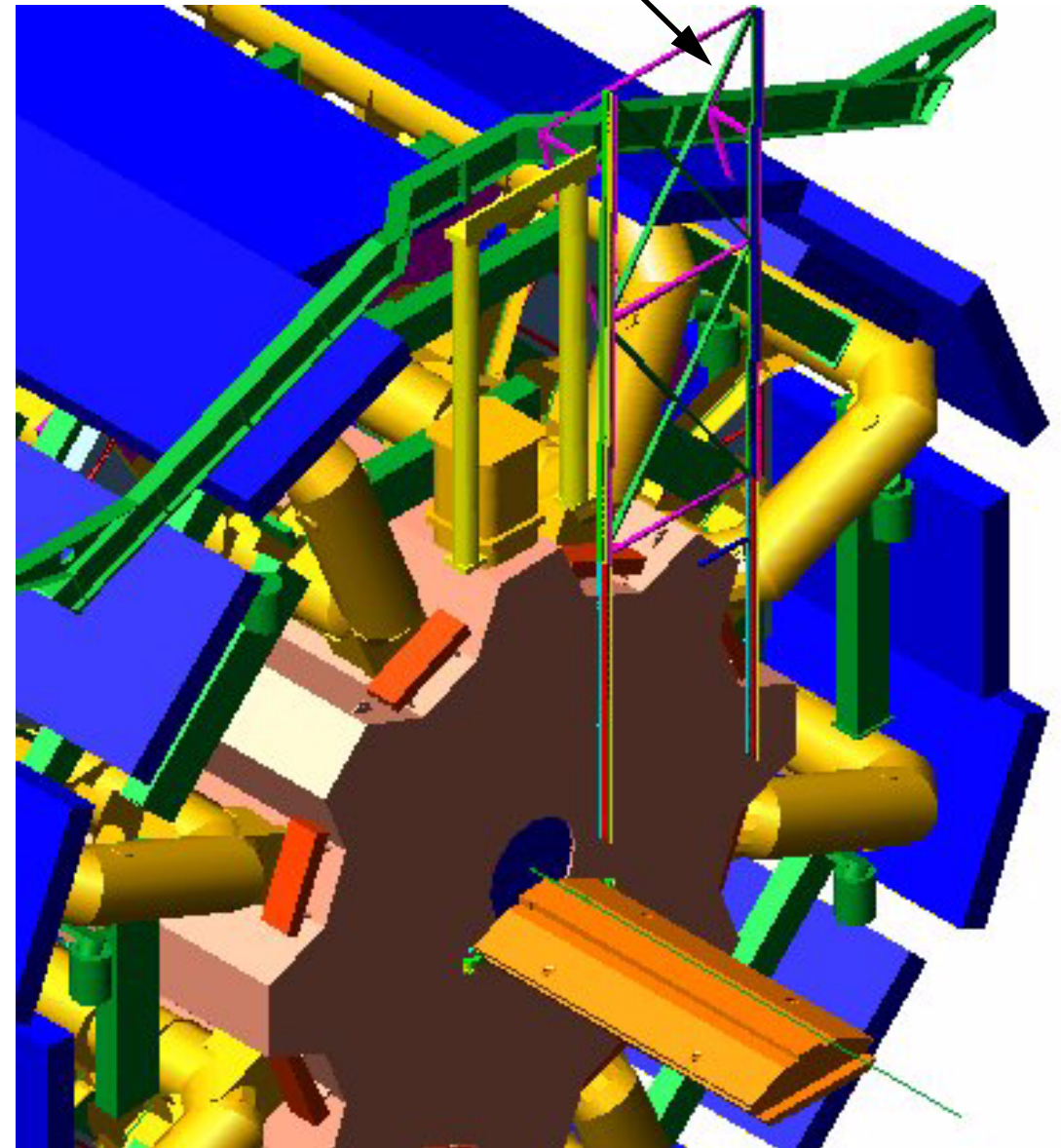
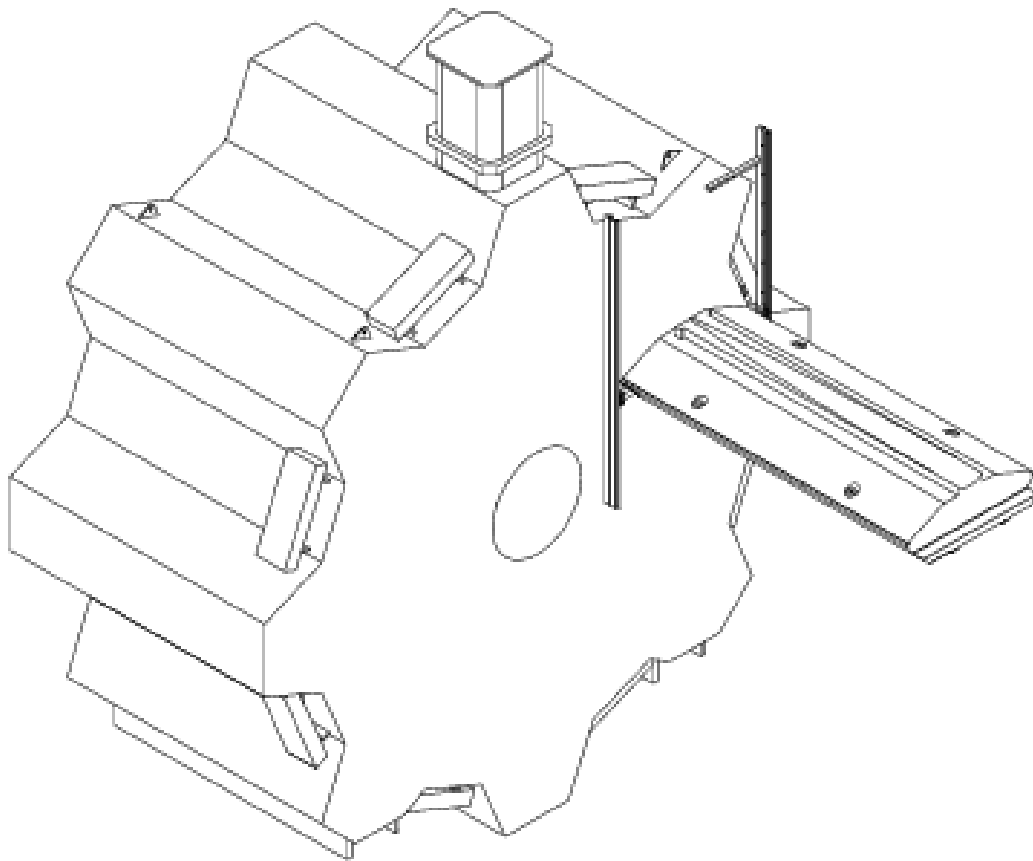

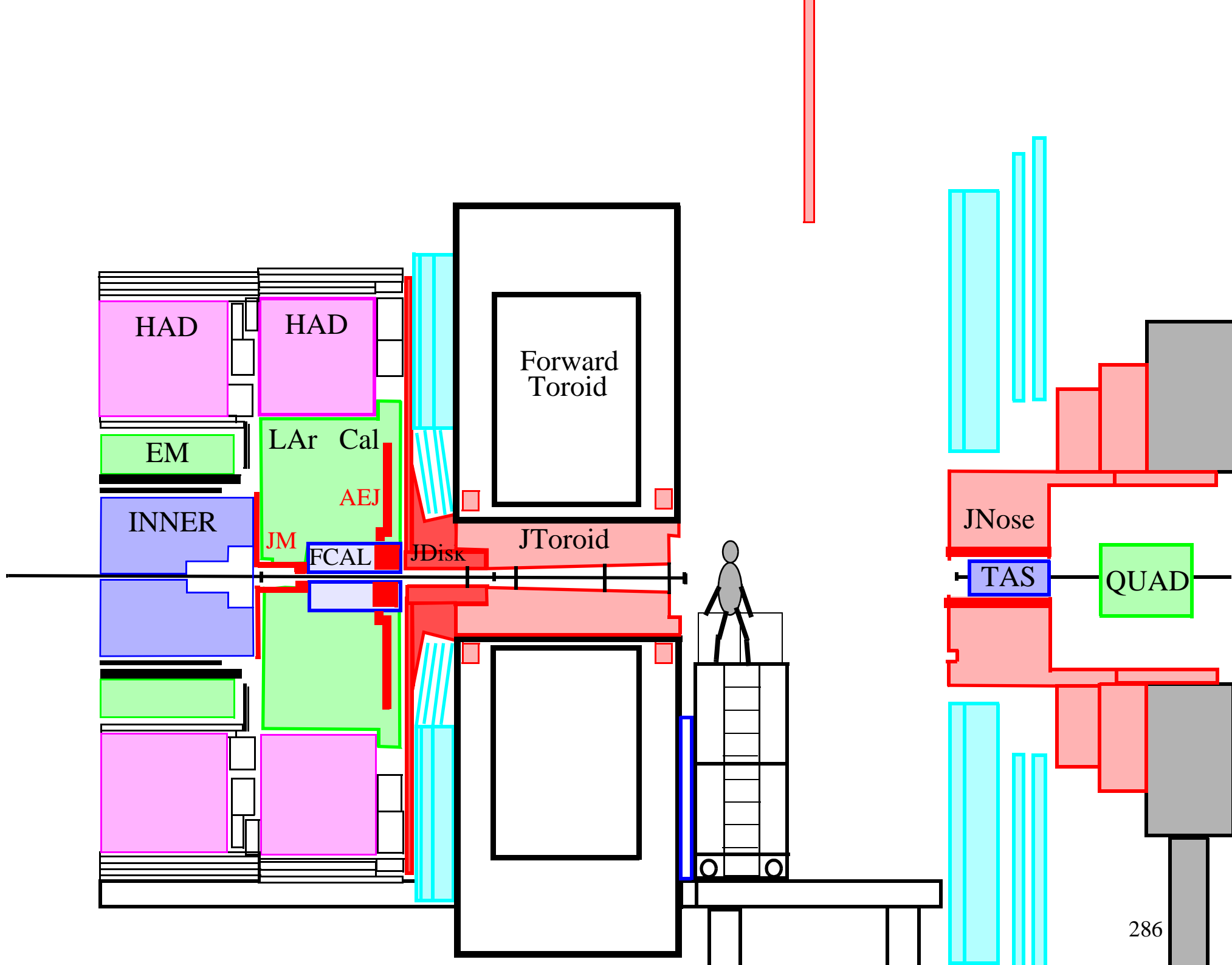

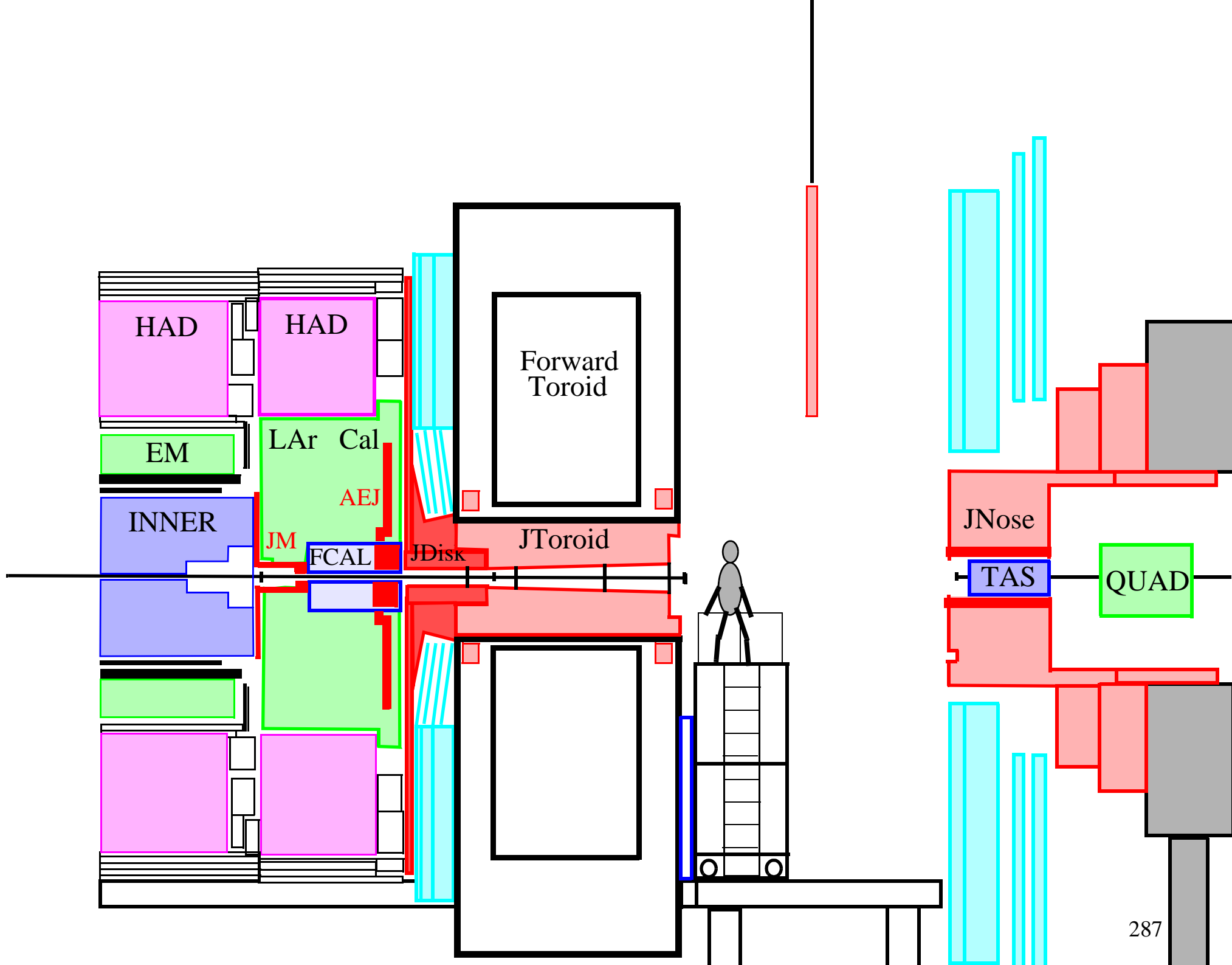

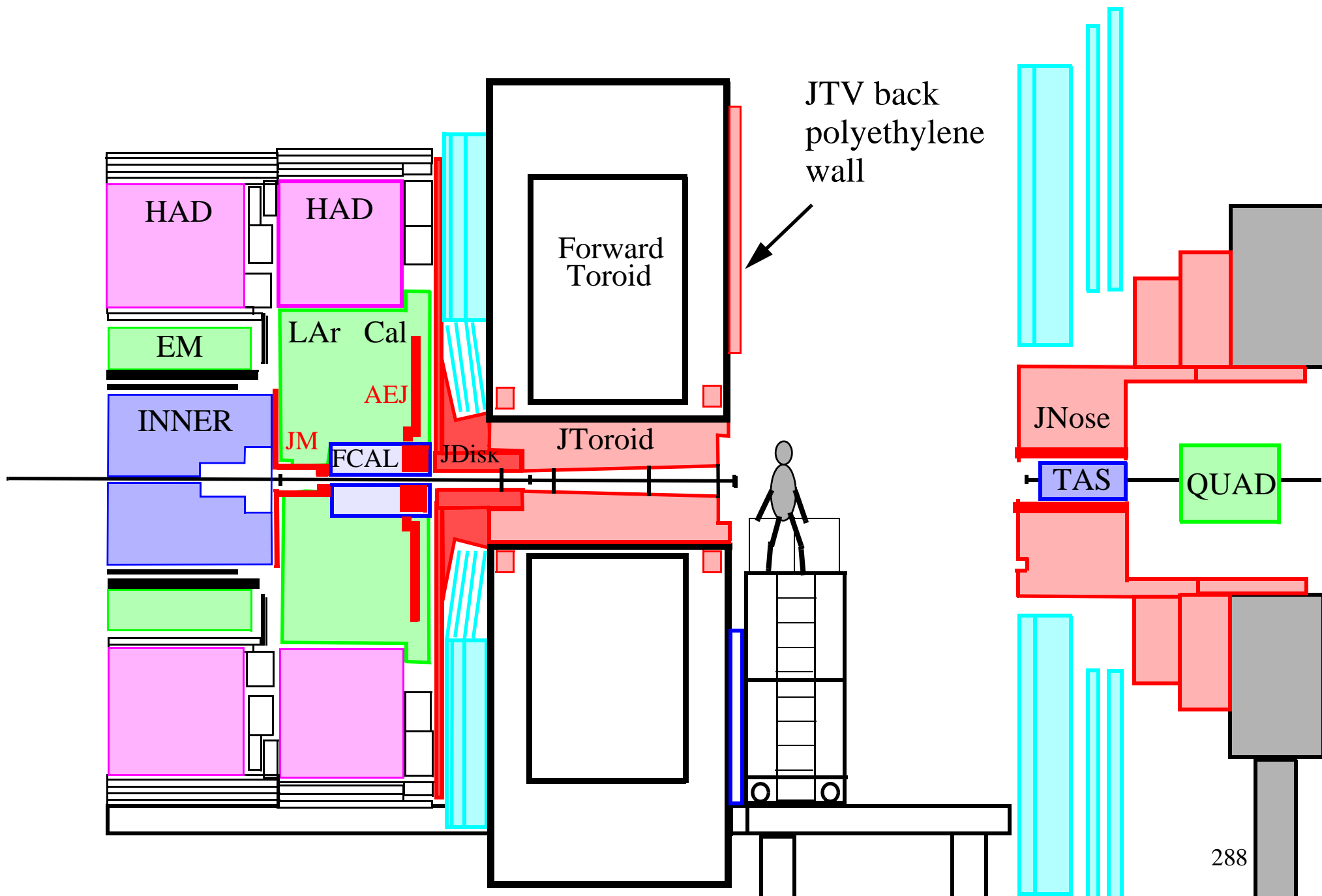

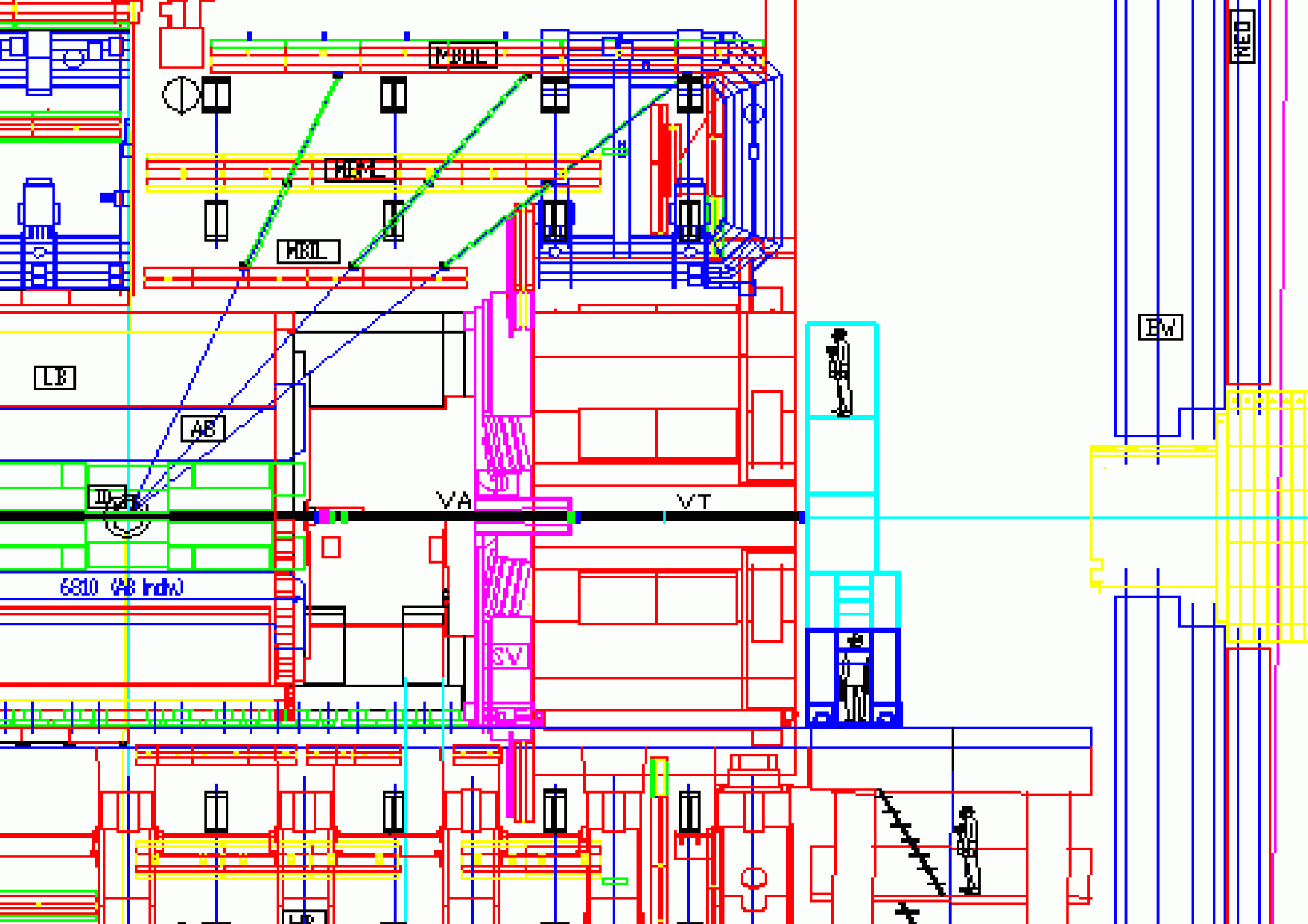

POST

POST

POST

LE

AB

ID

VA

VT

3V

BW

MED

6810 (AB Indiv)

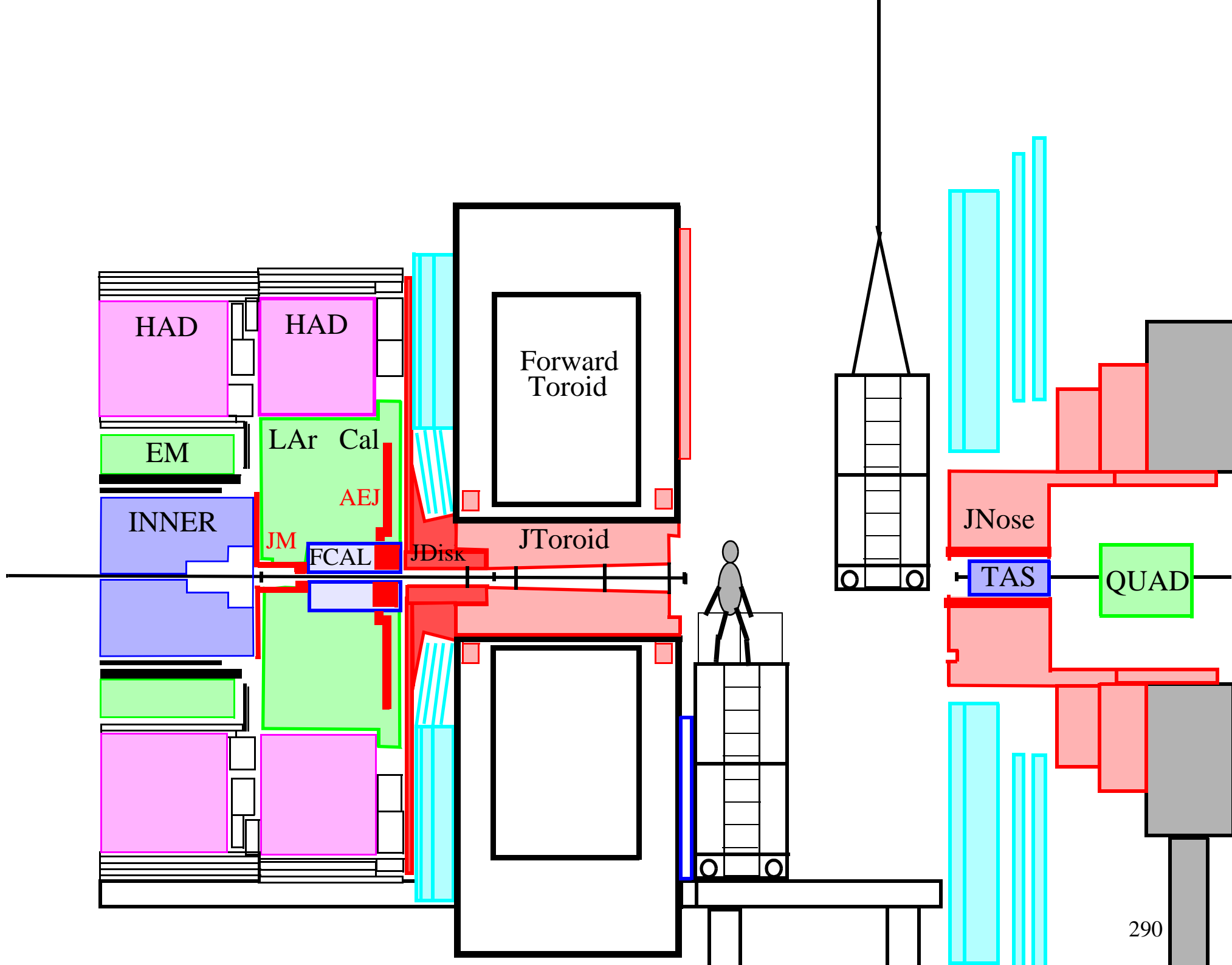

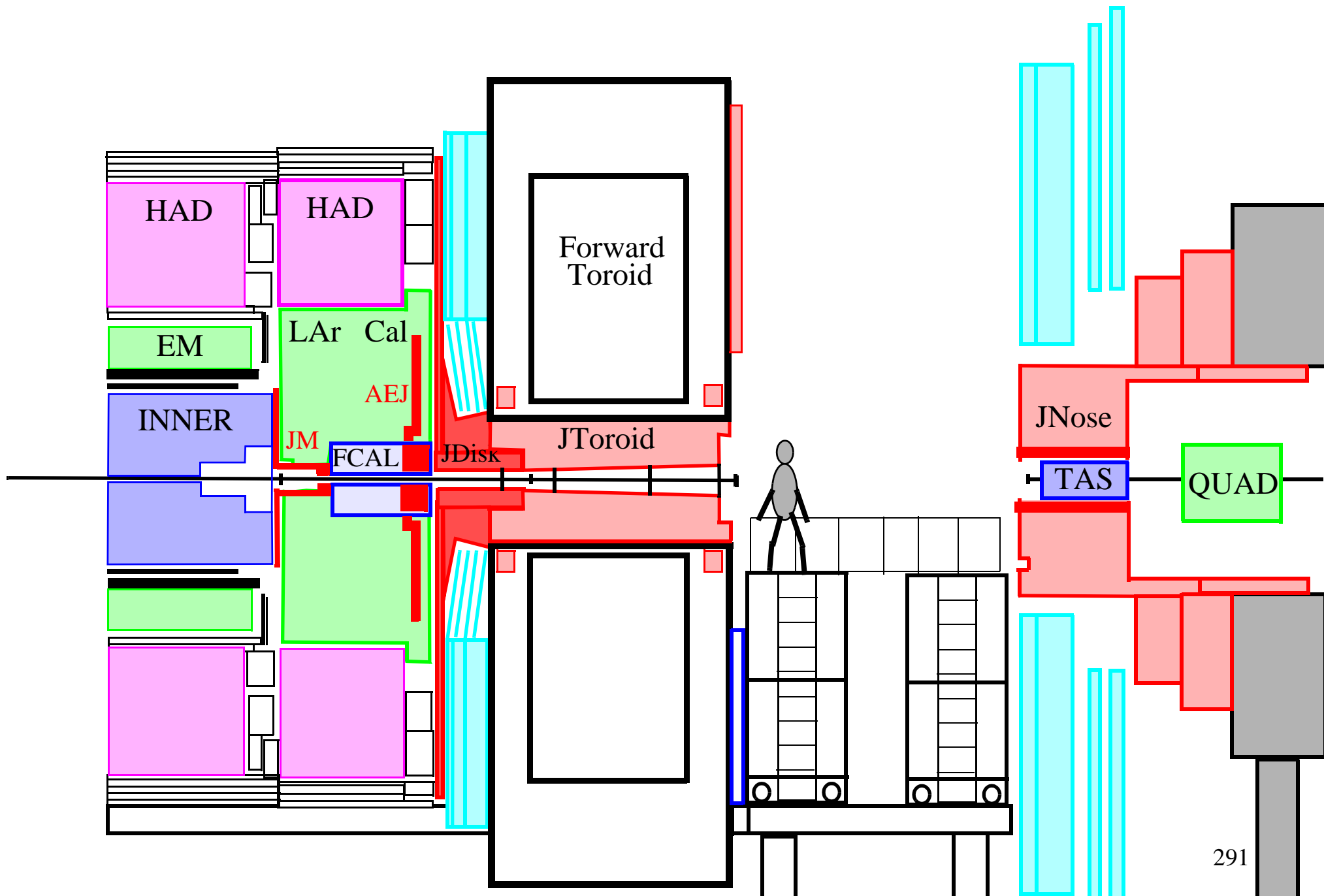

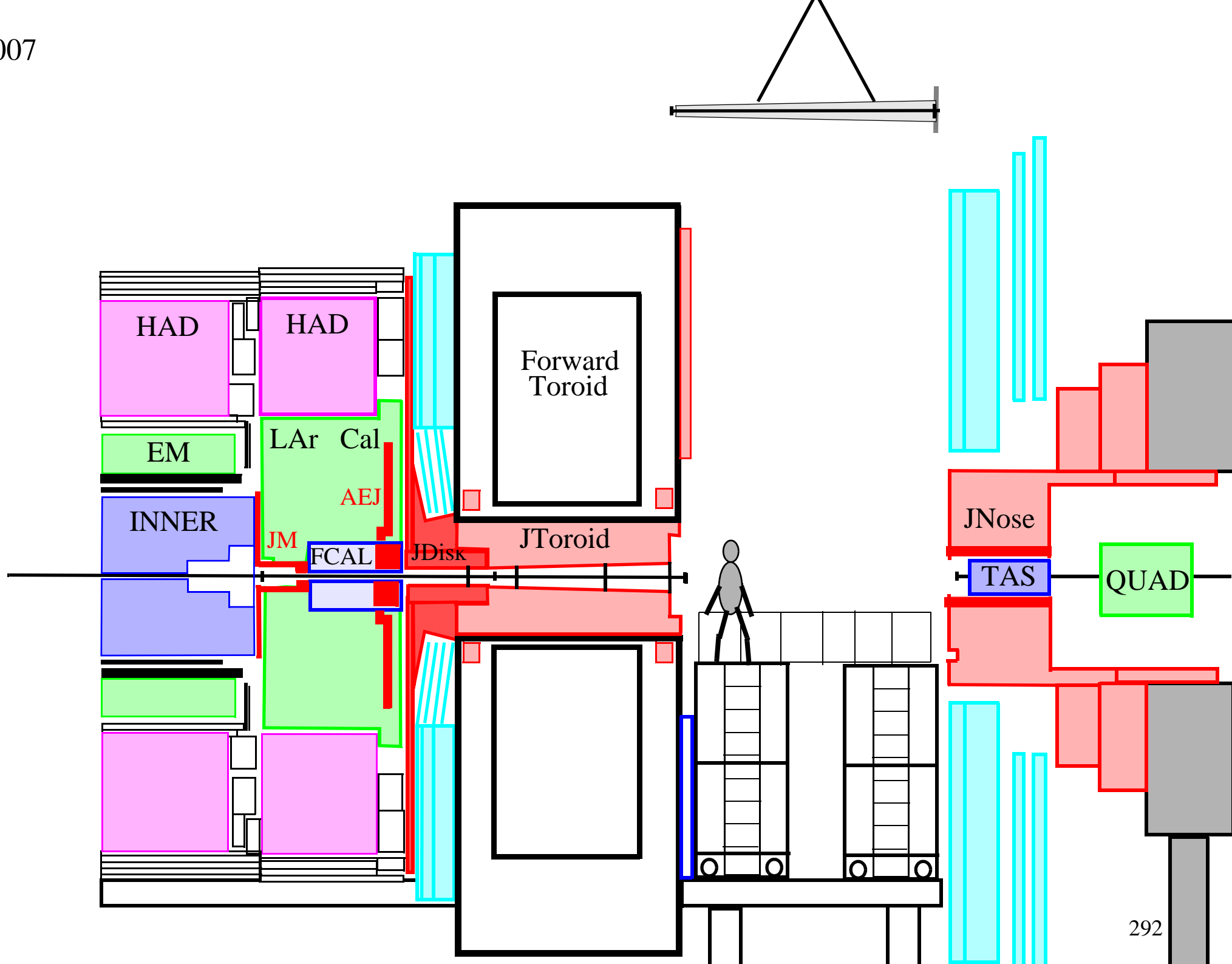

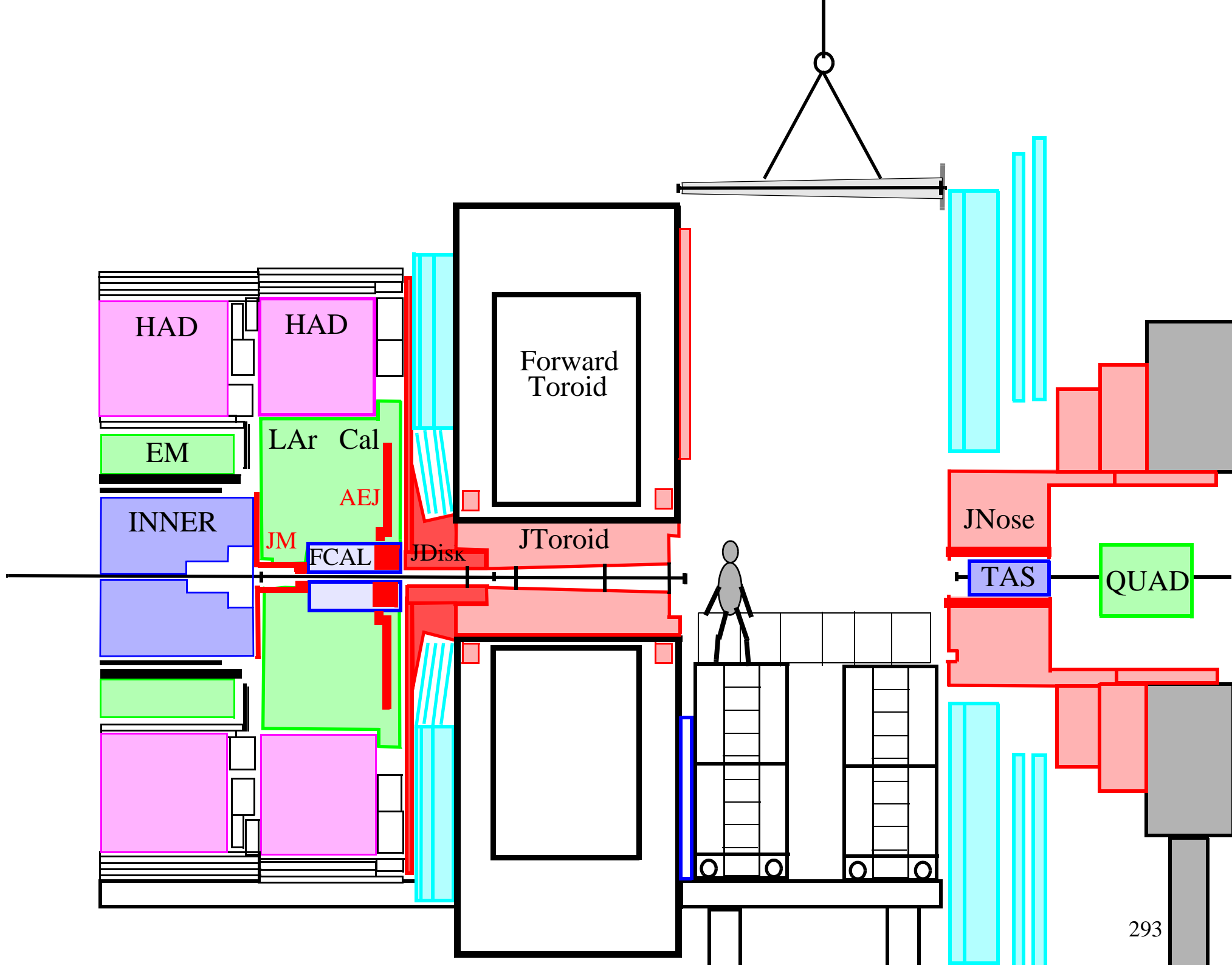

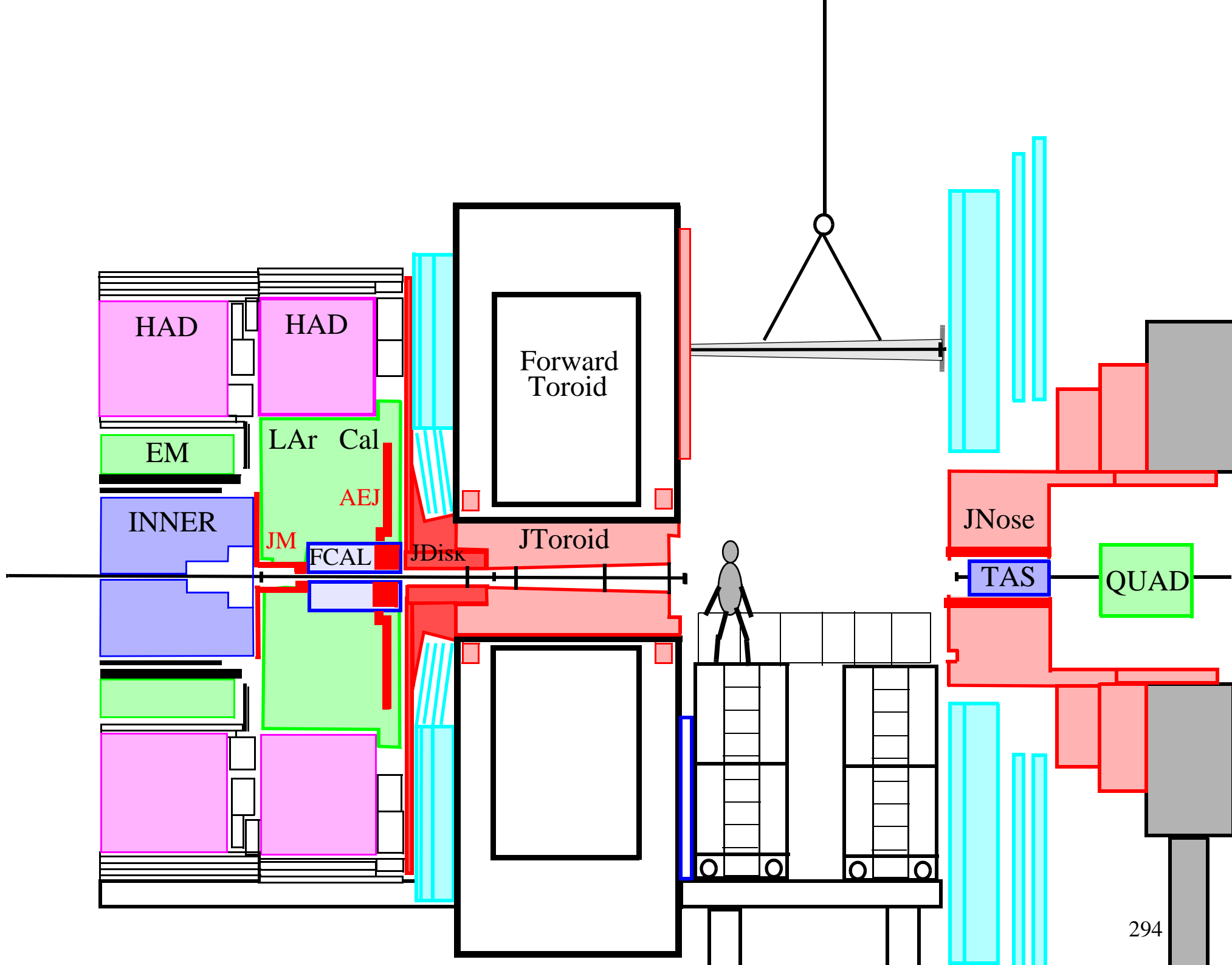

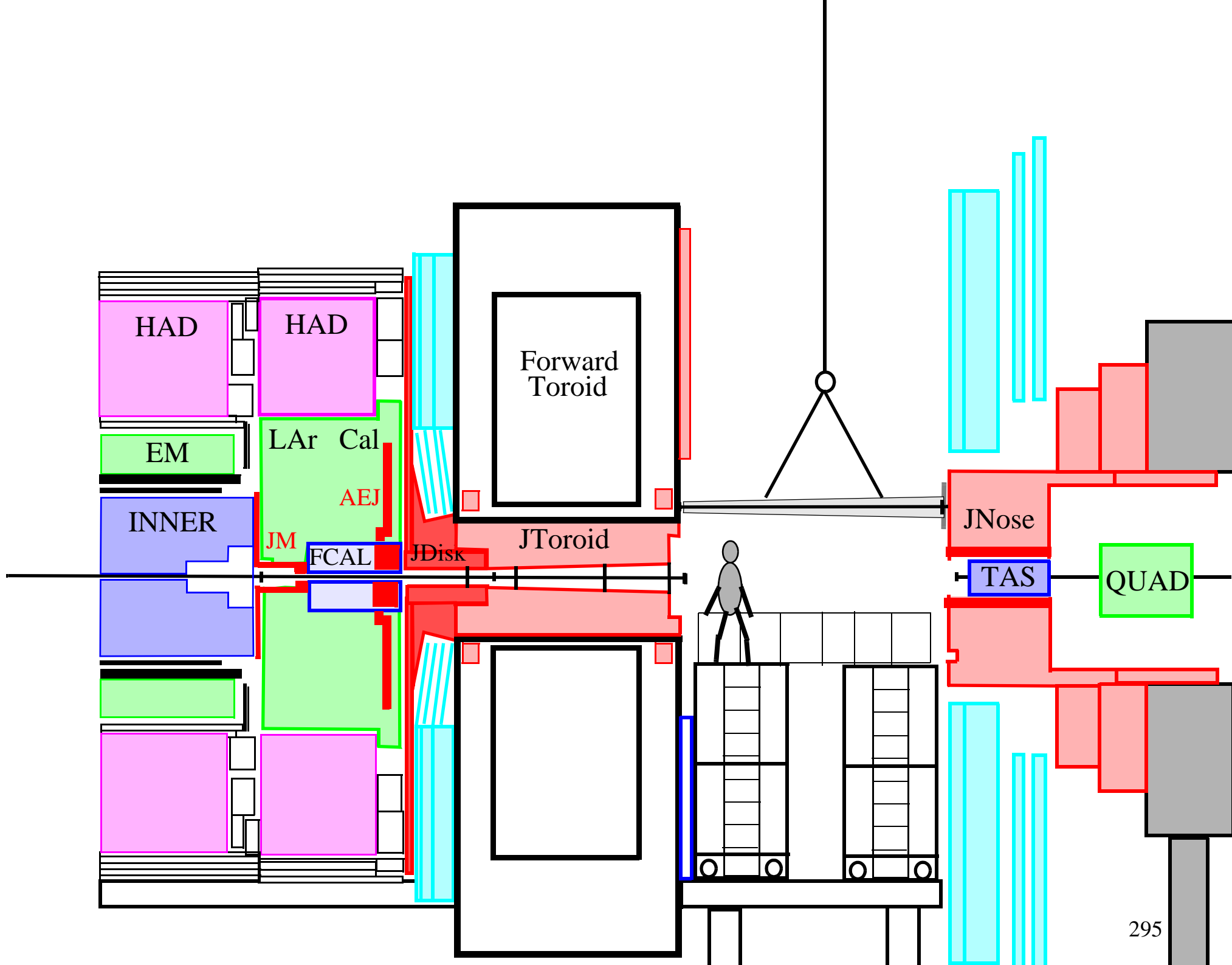

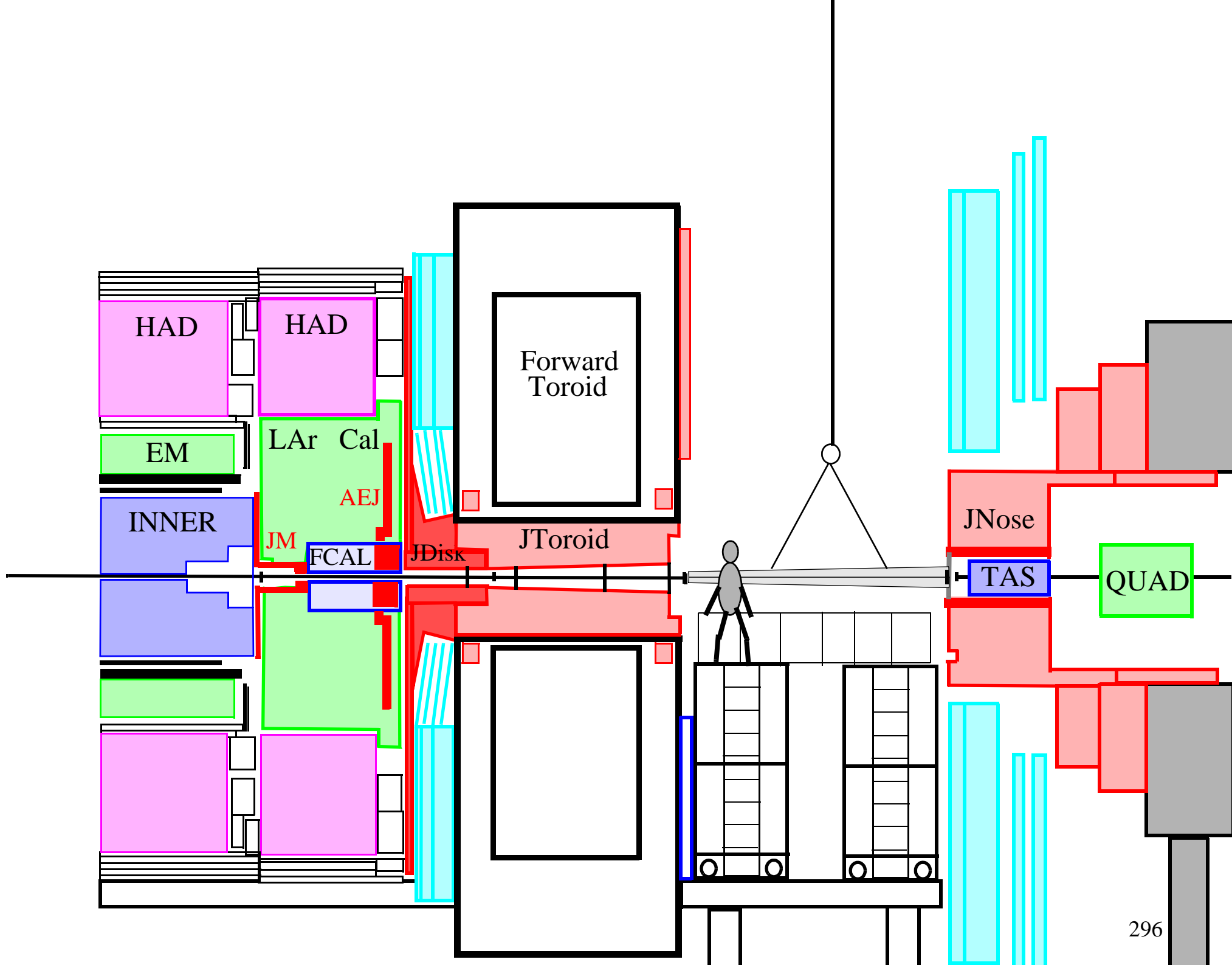

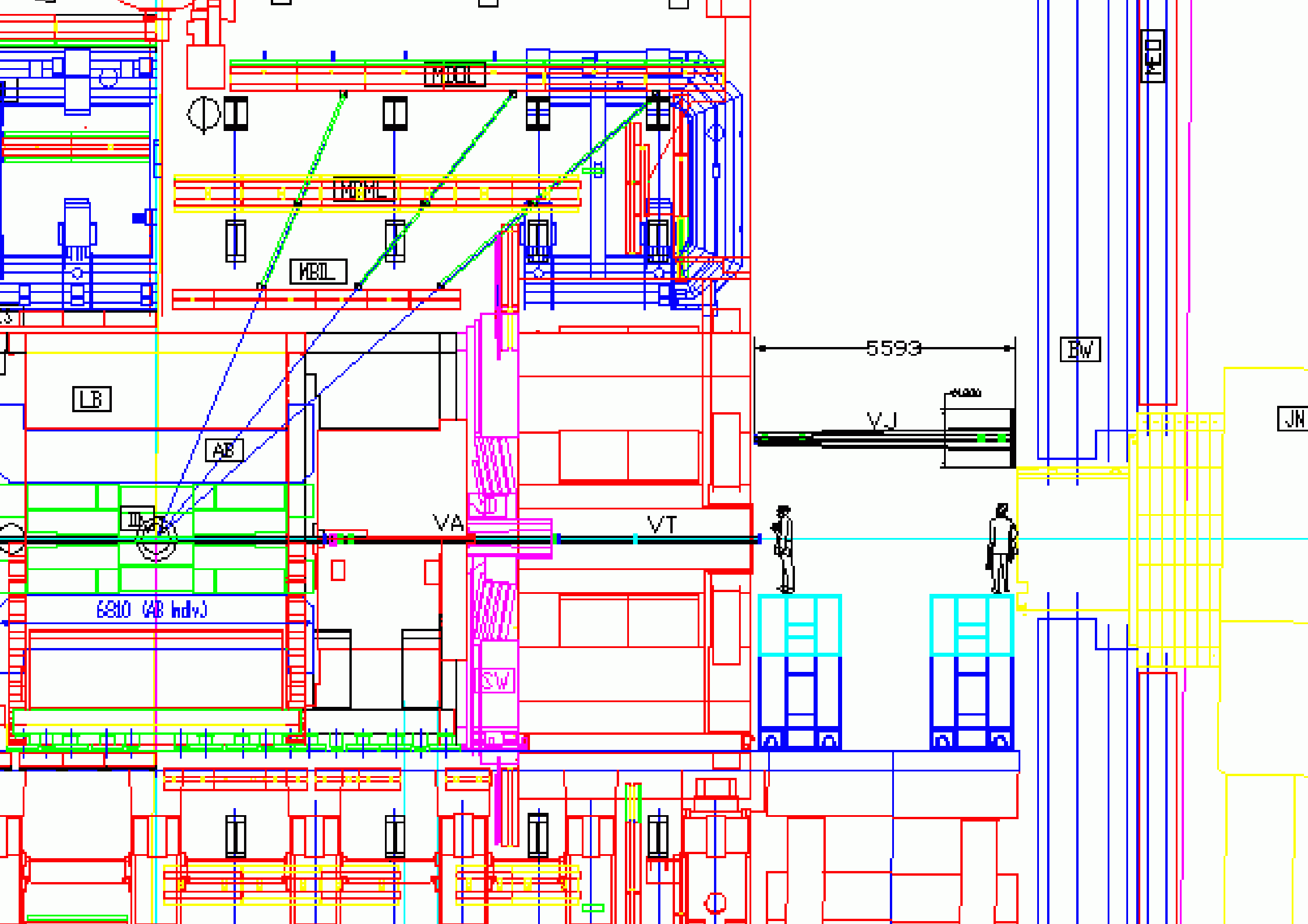

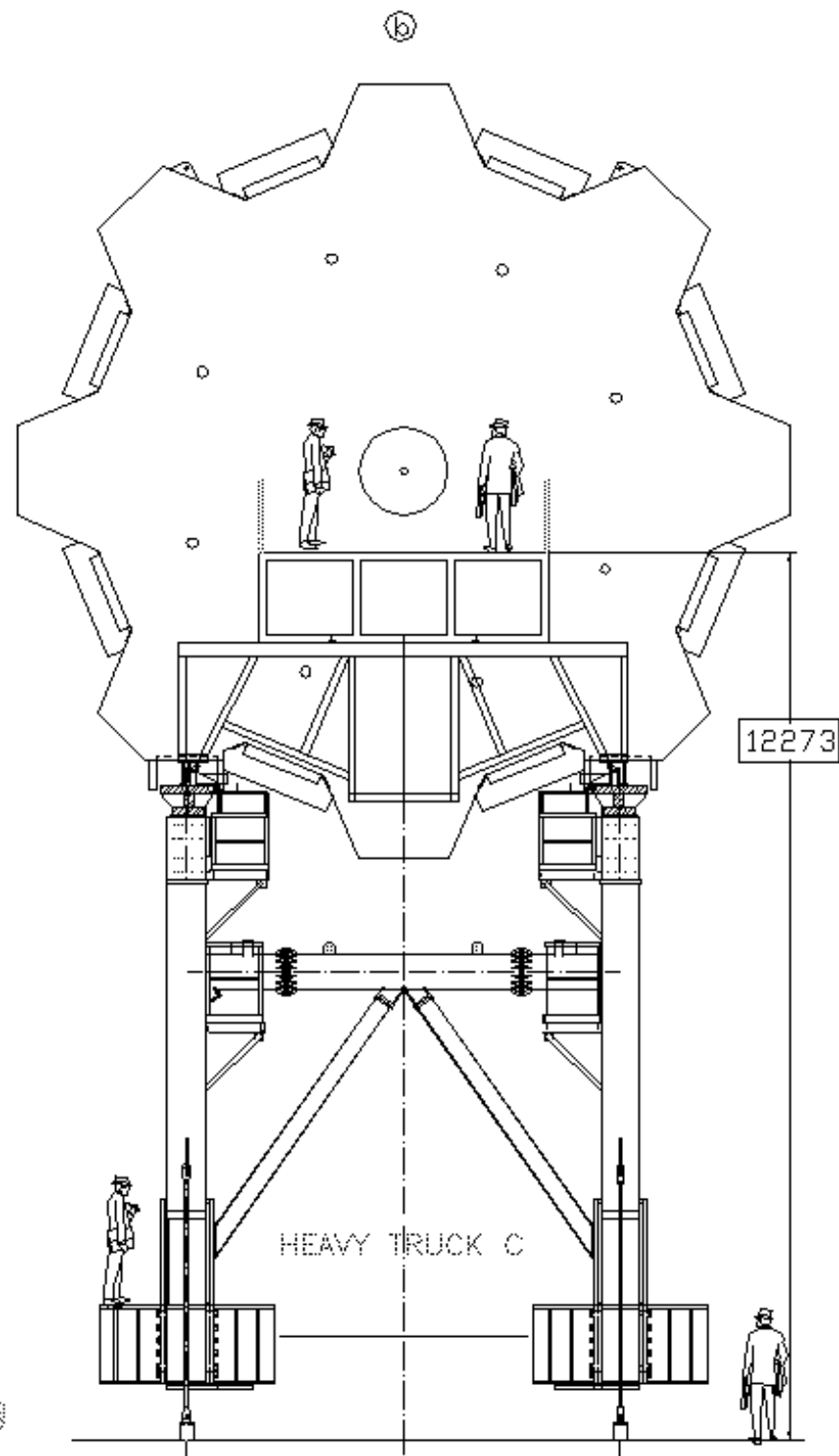

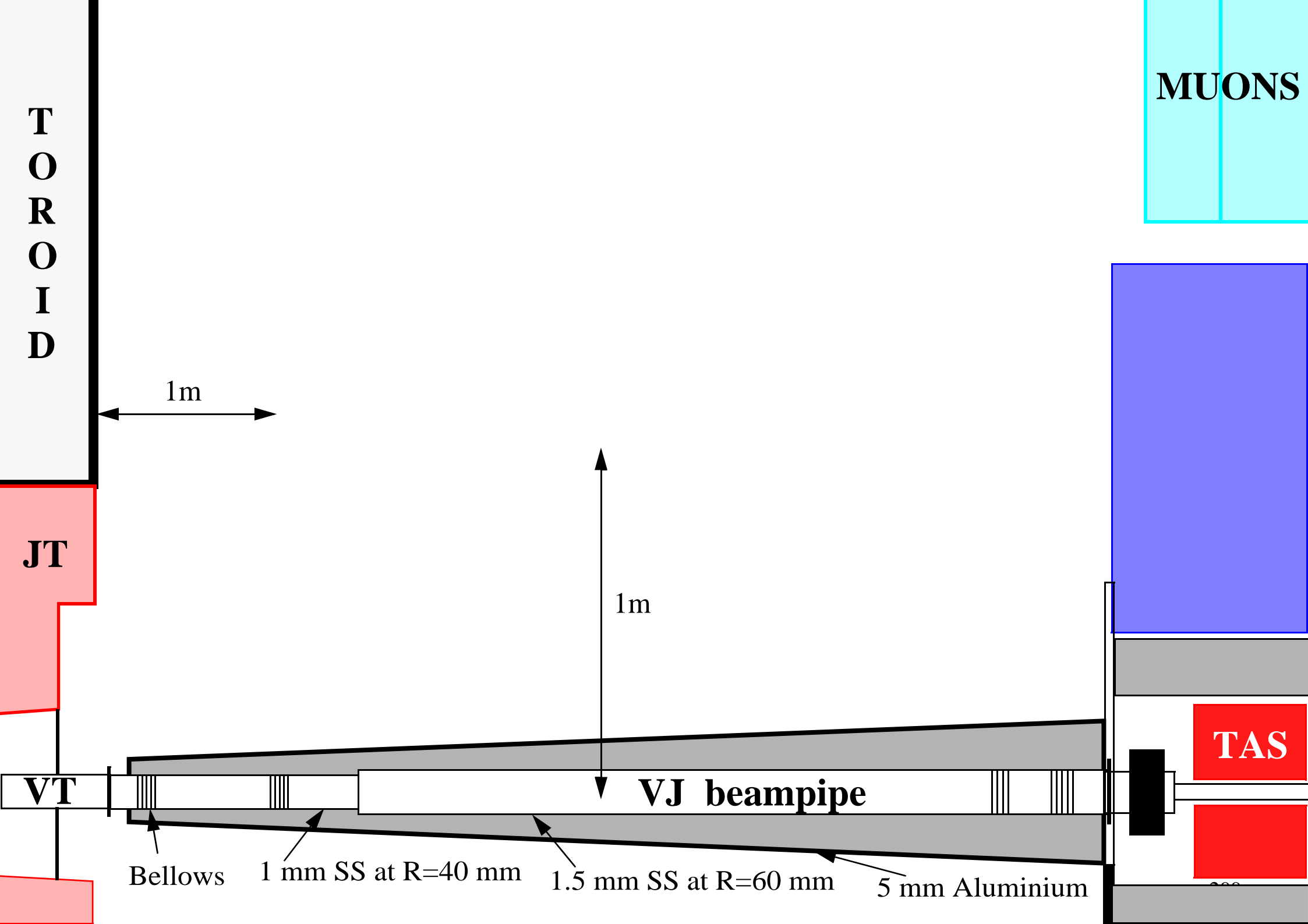

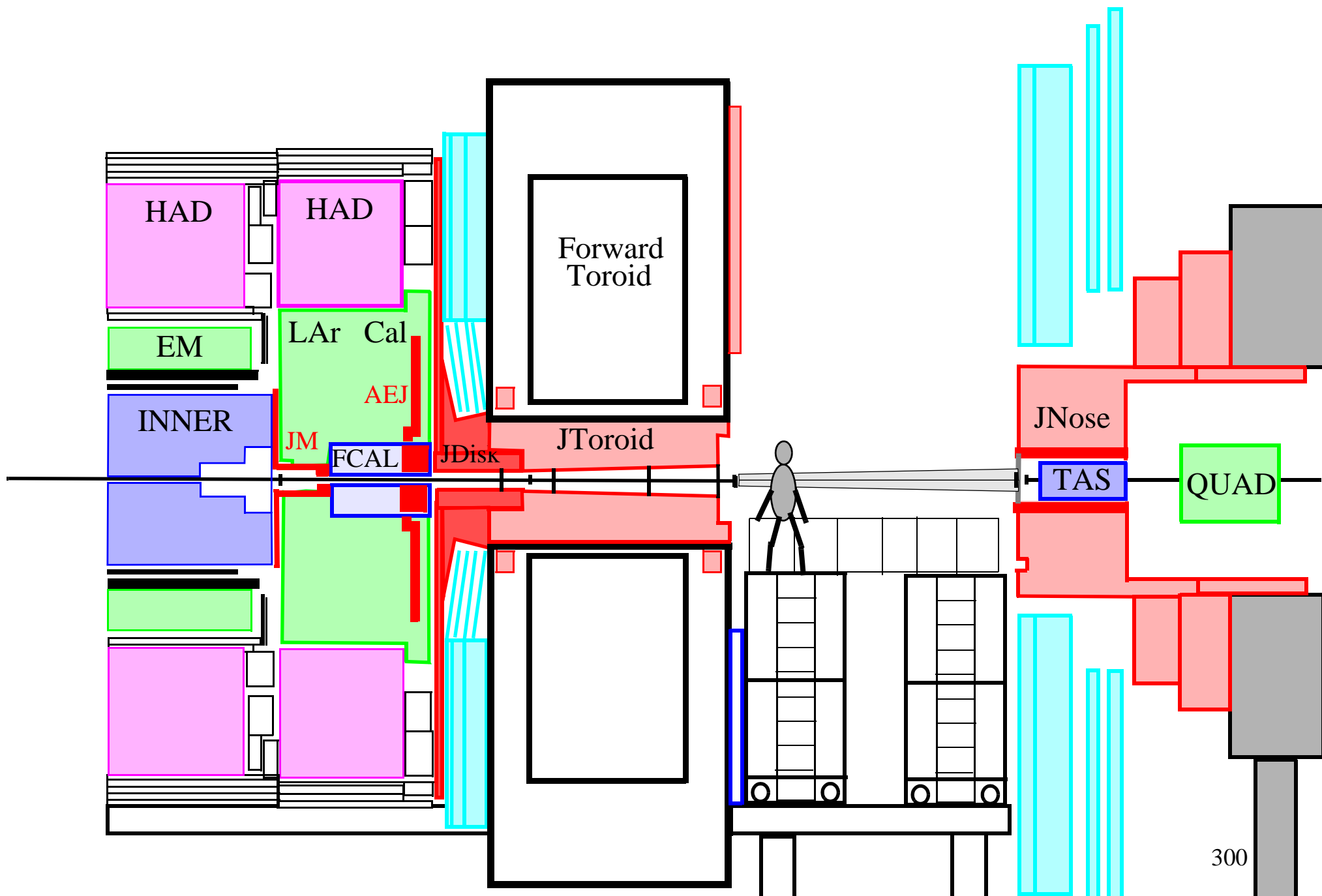

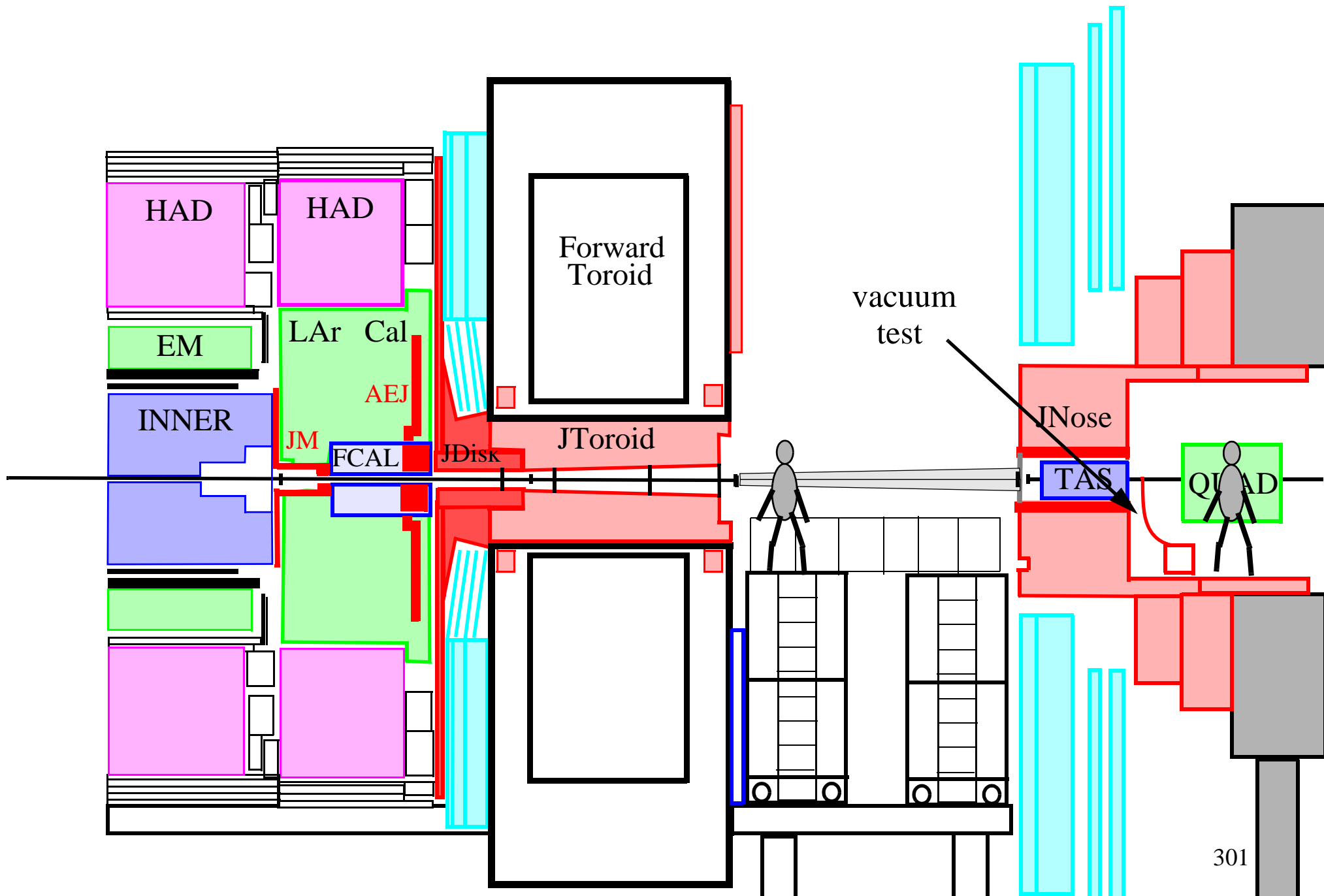

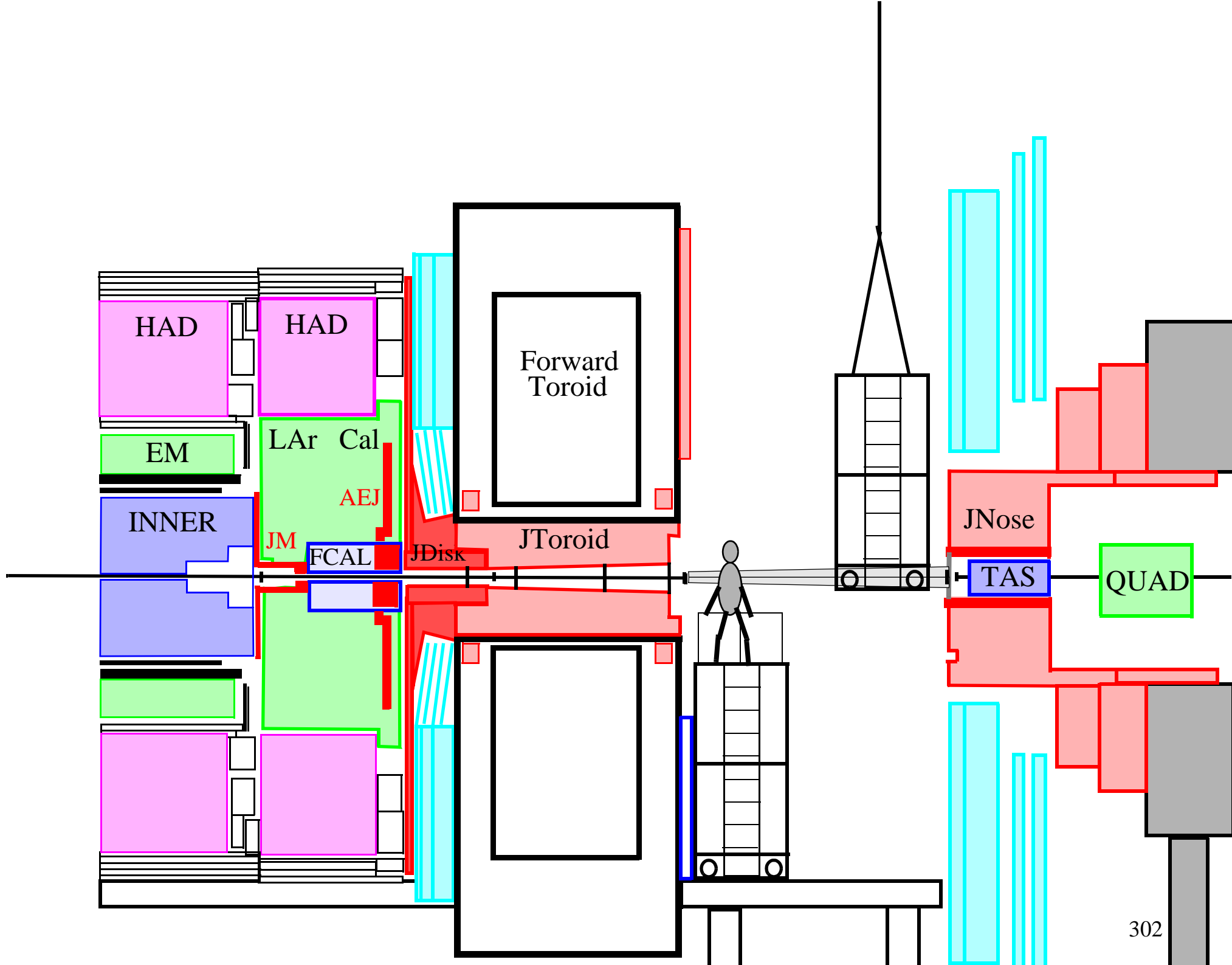

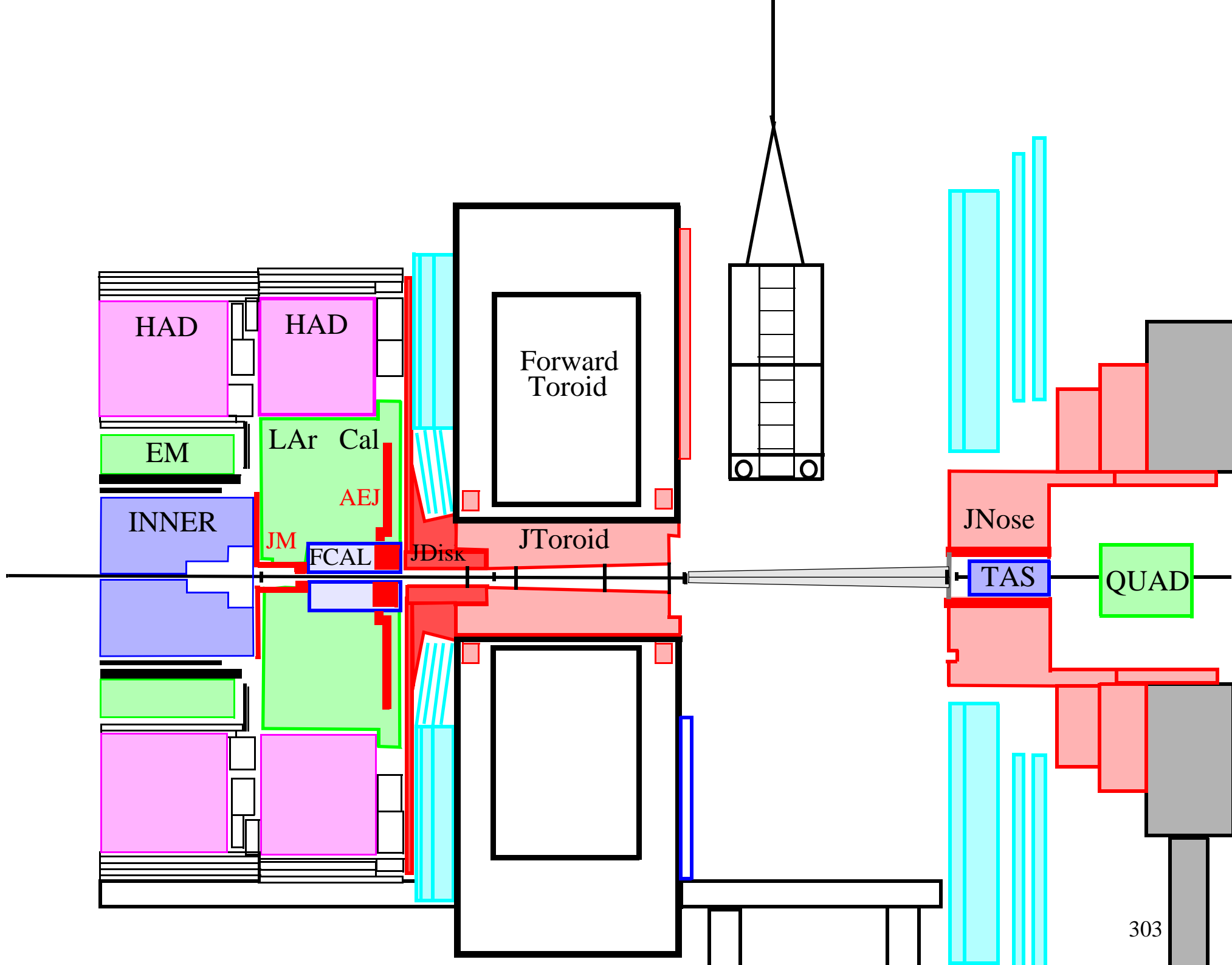

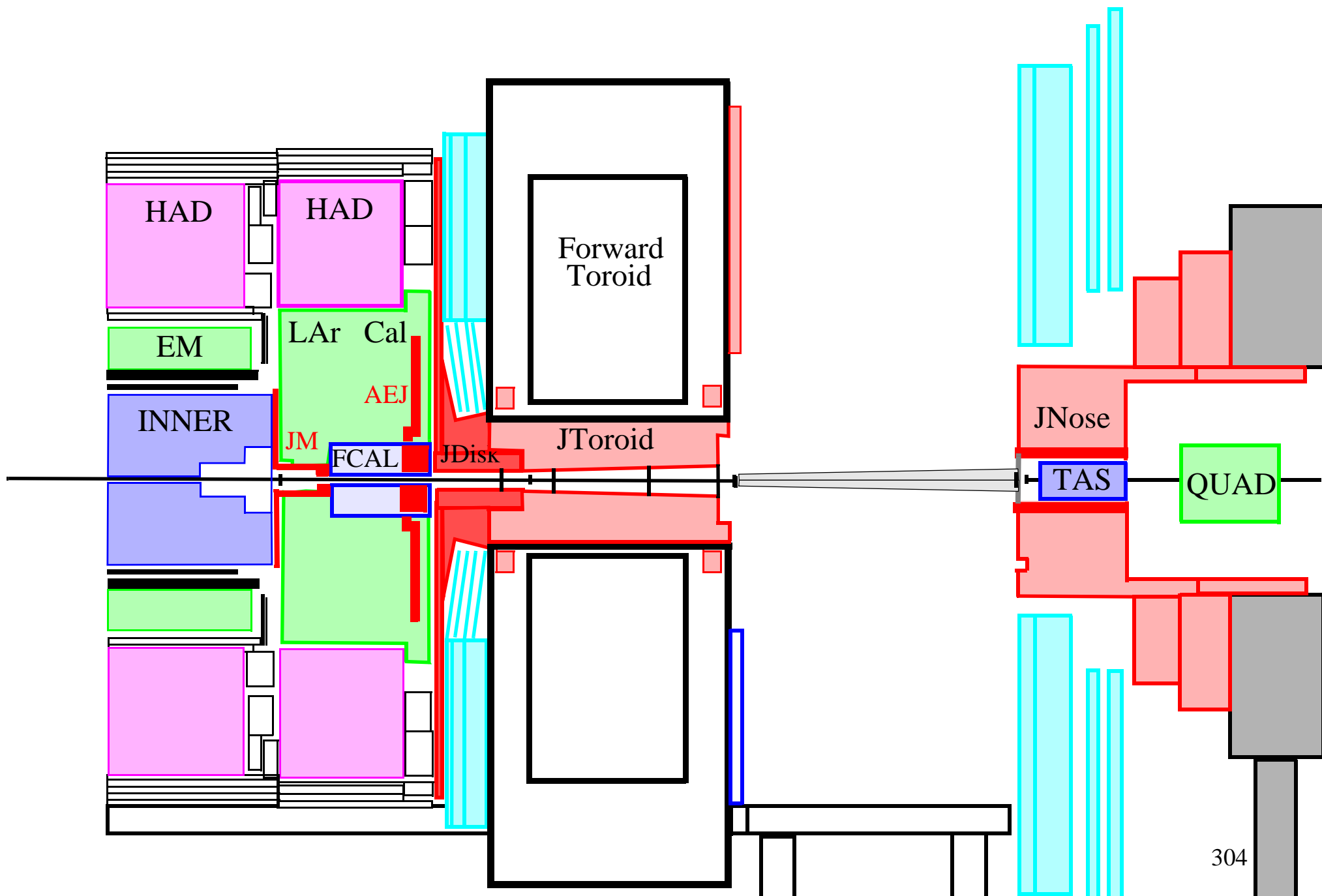

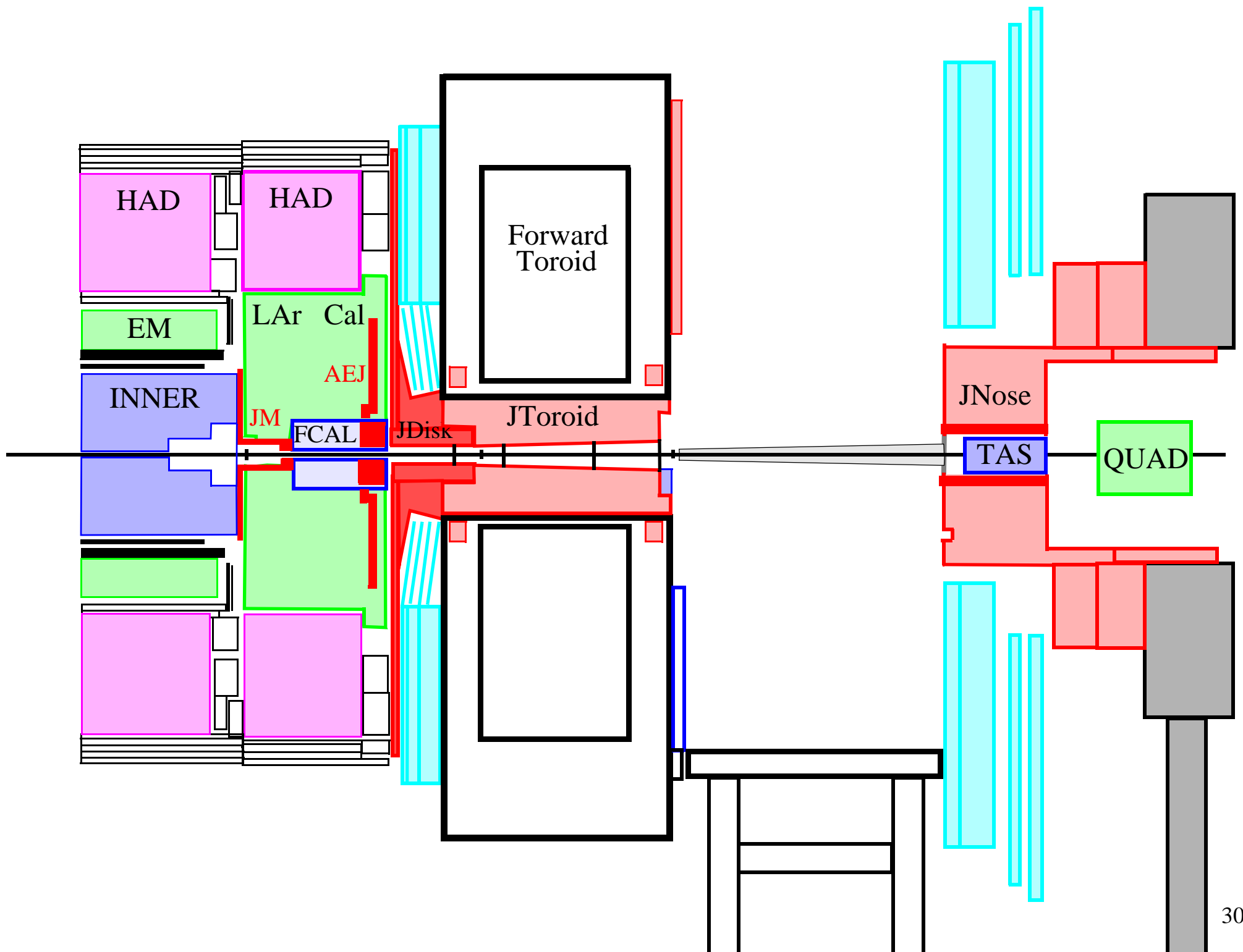

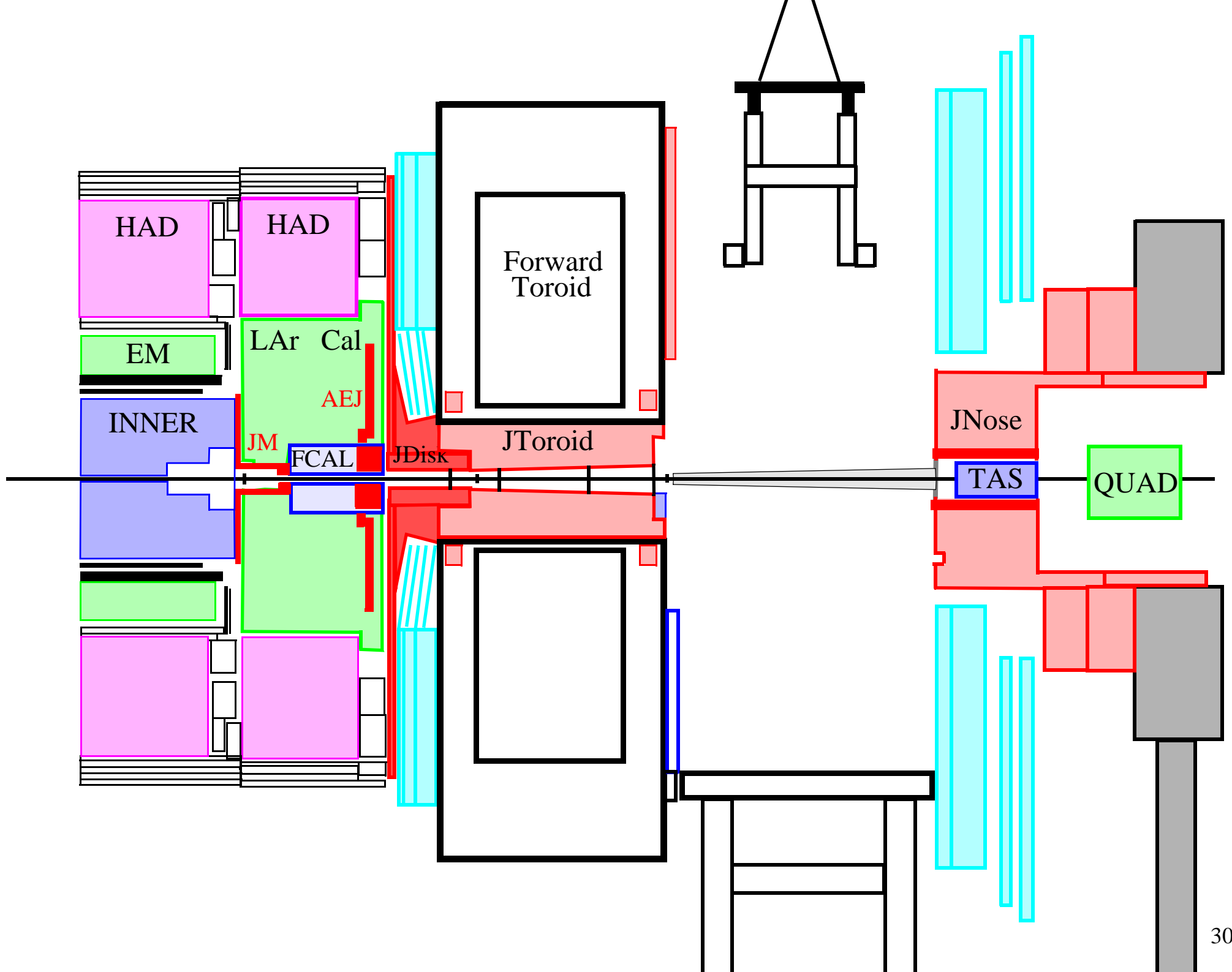

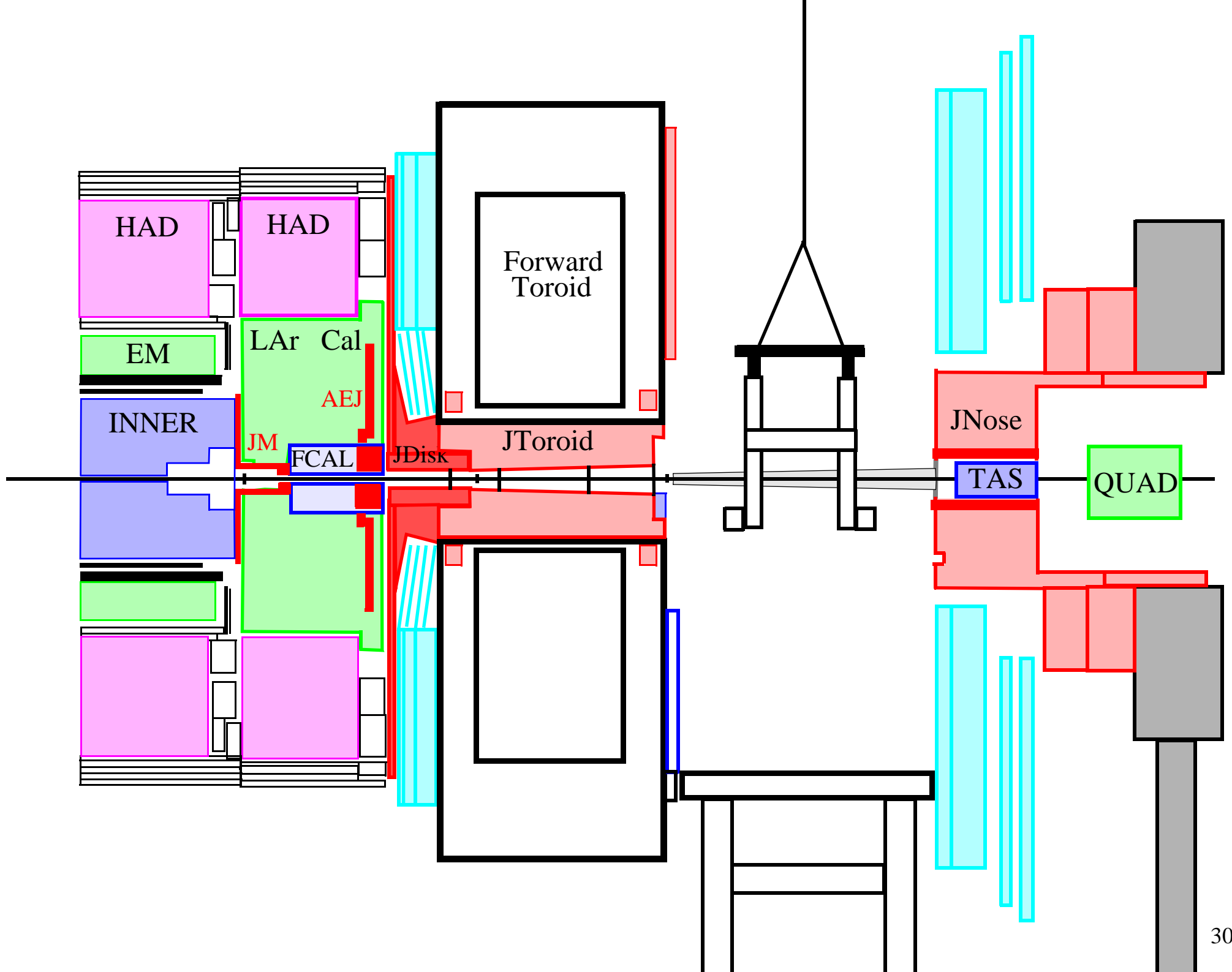

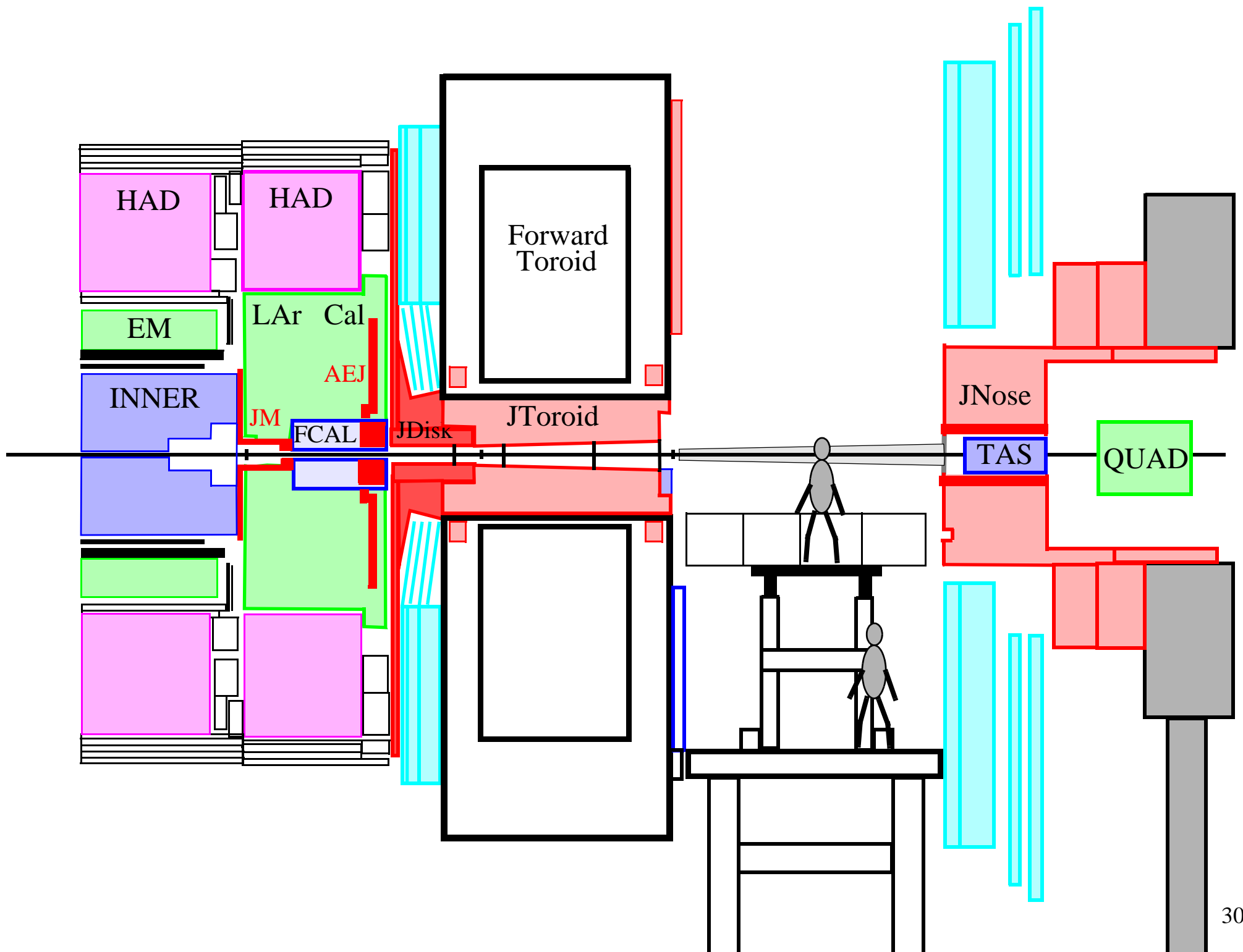

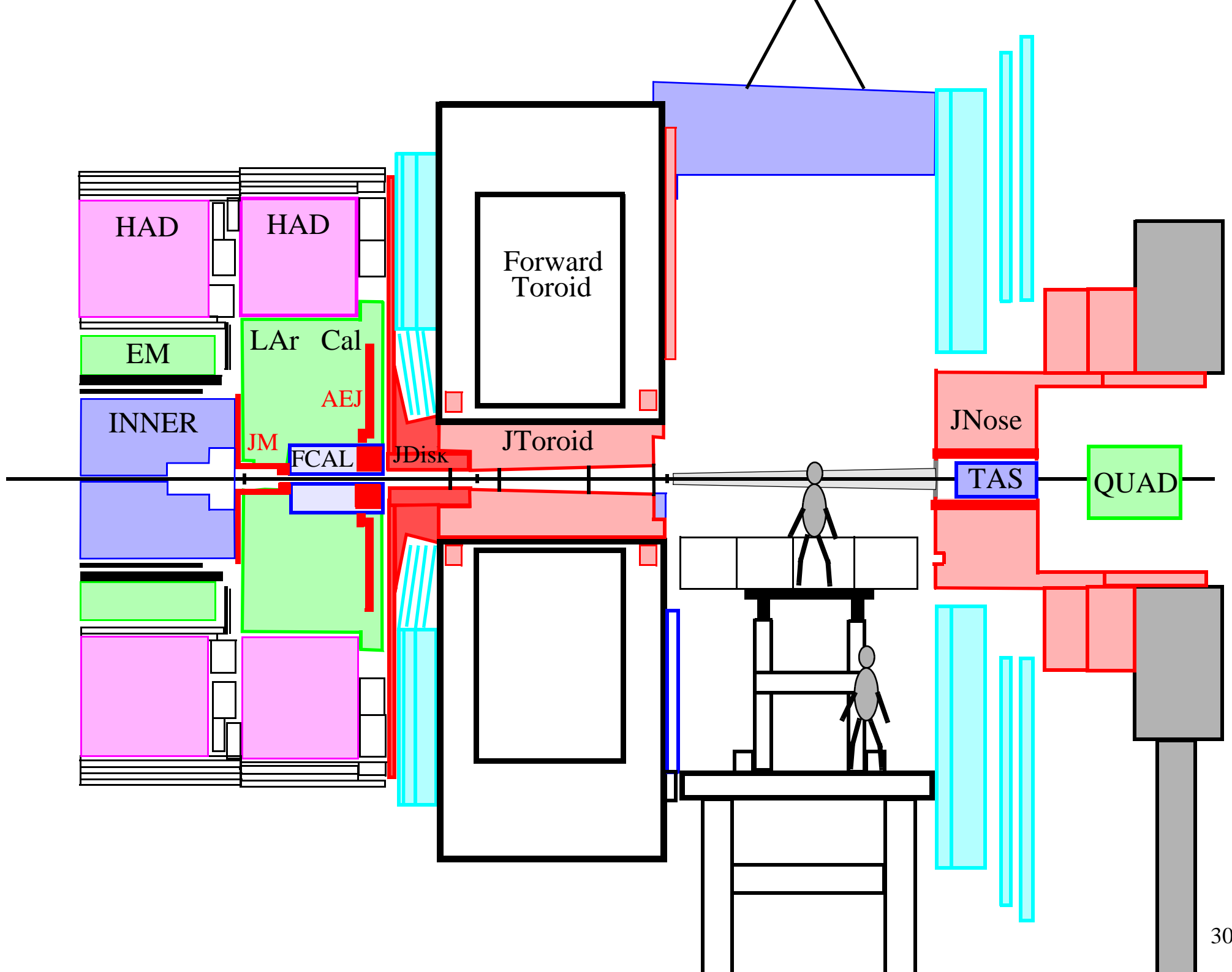

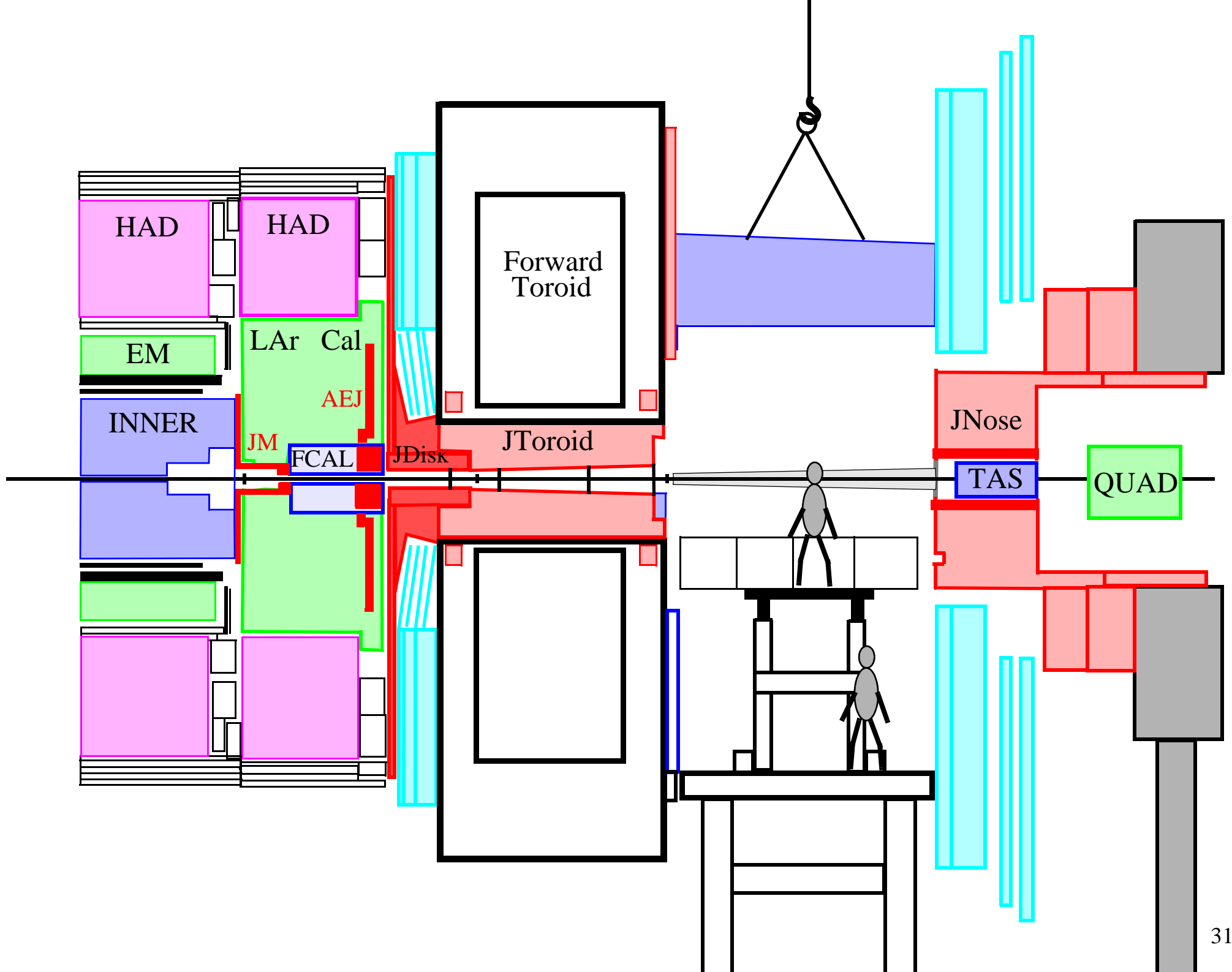

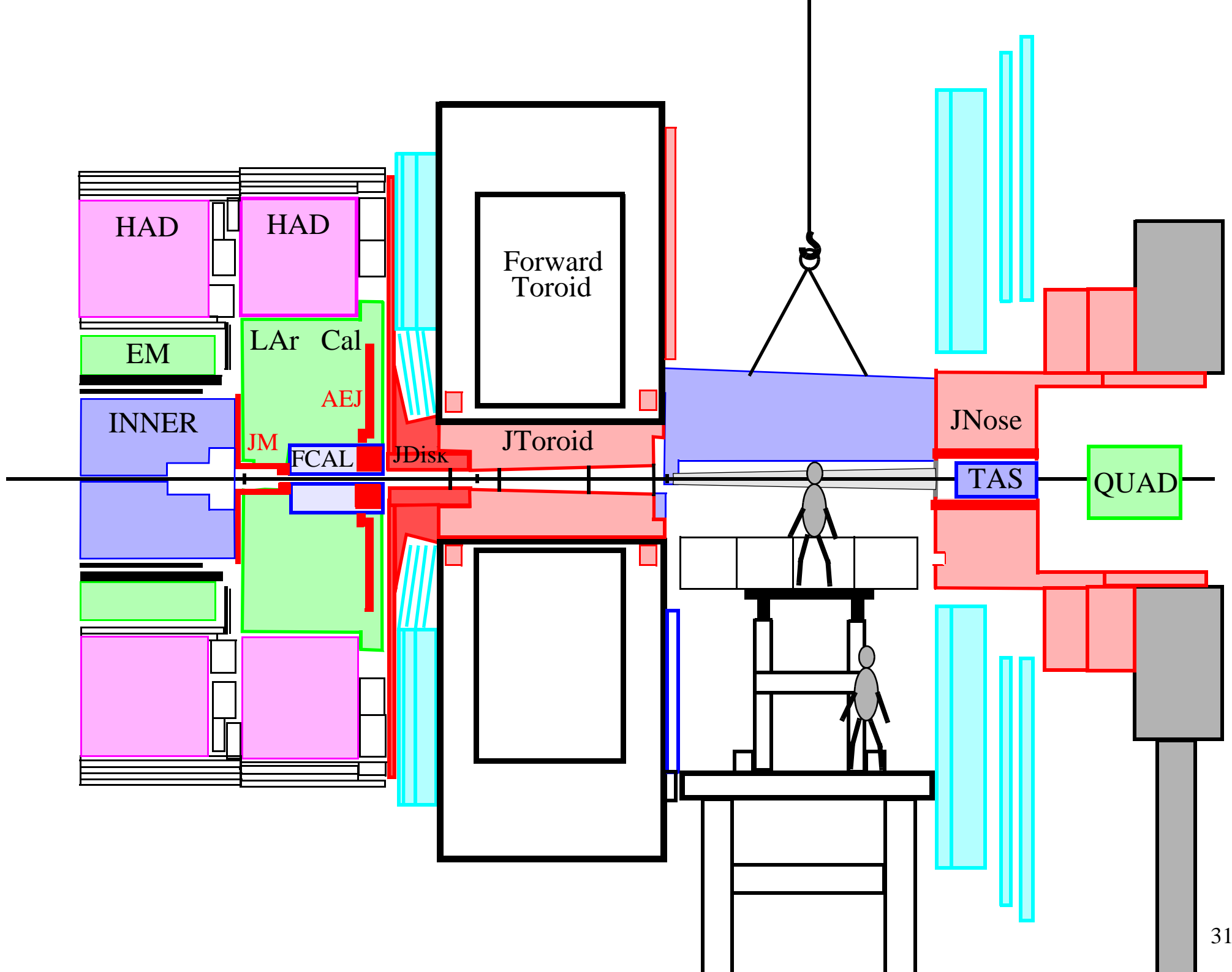

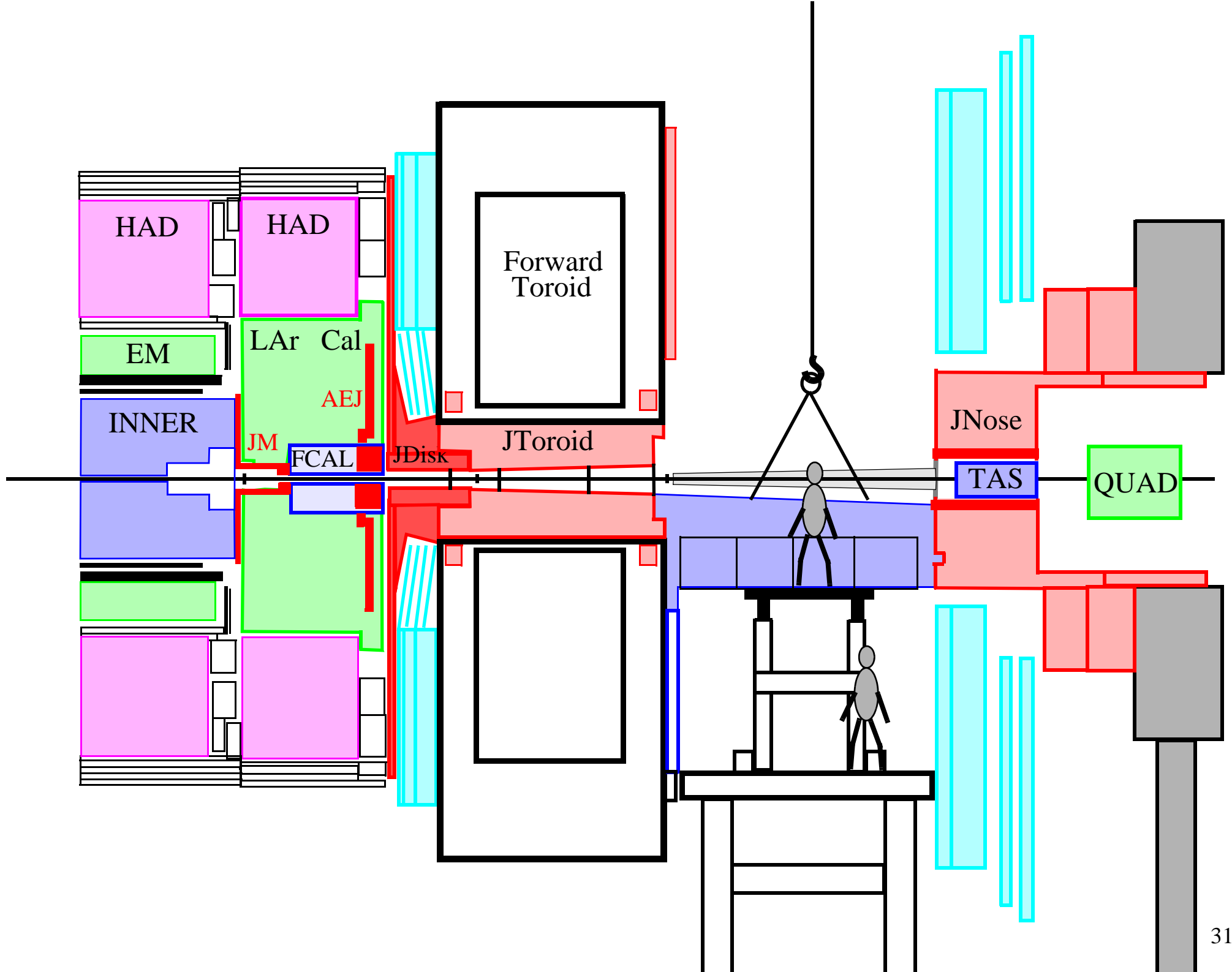

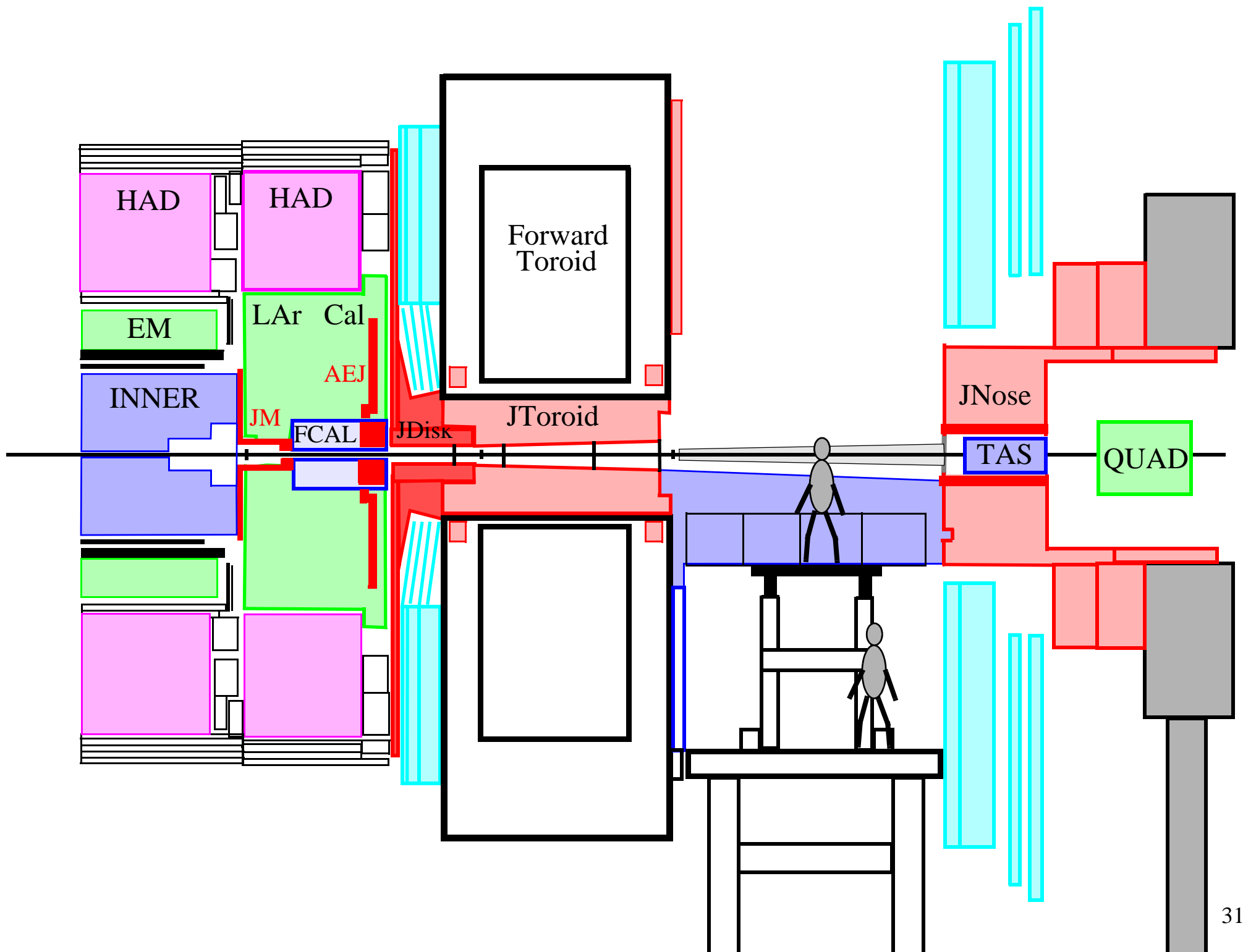

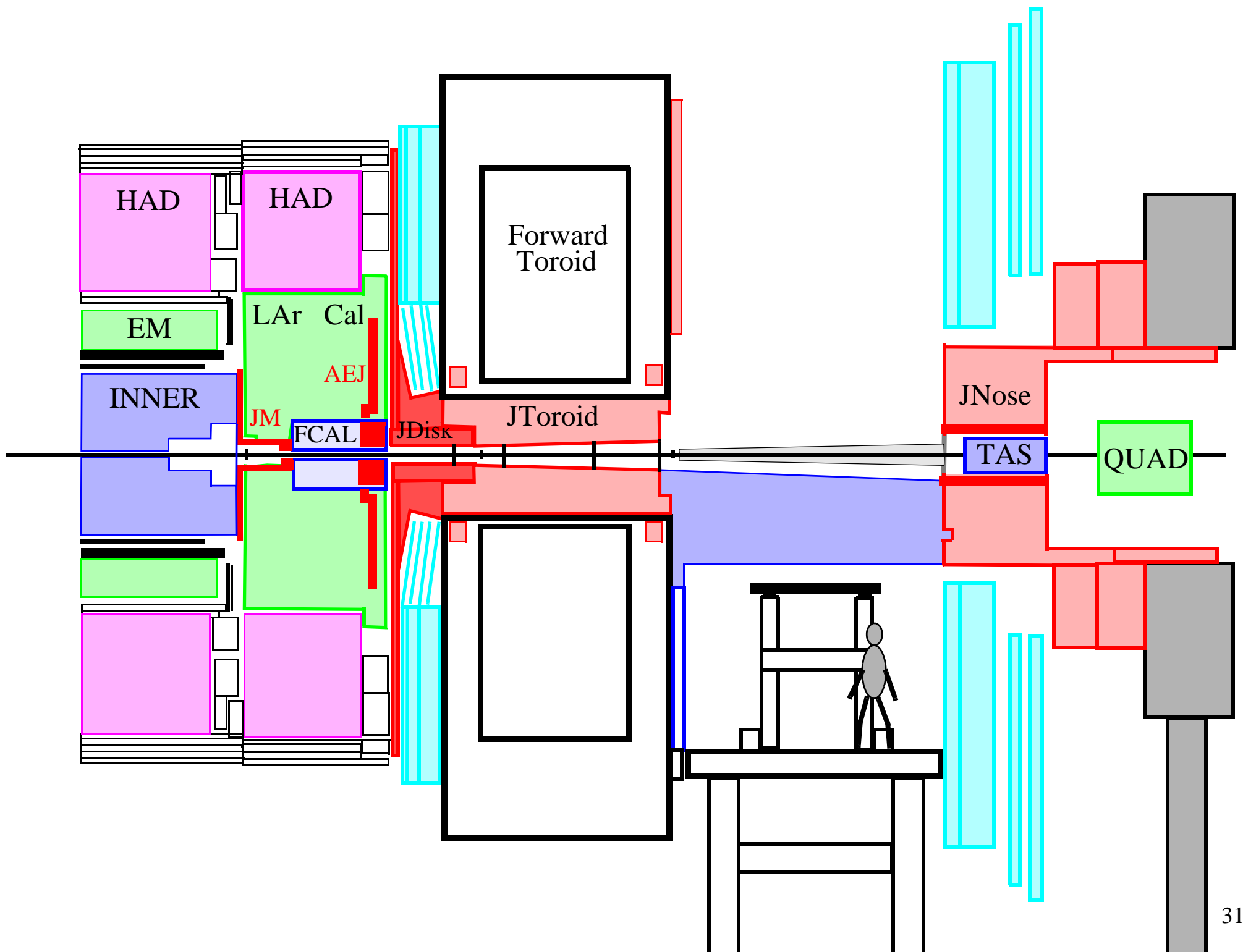

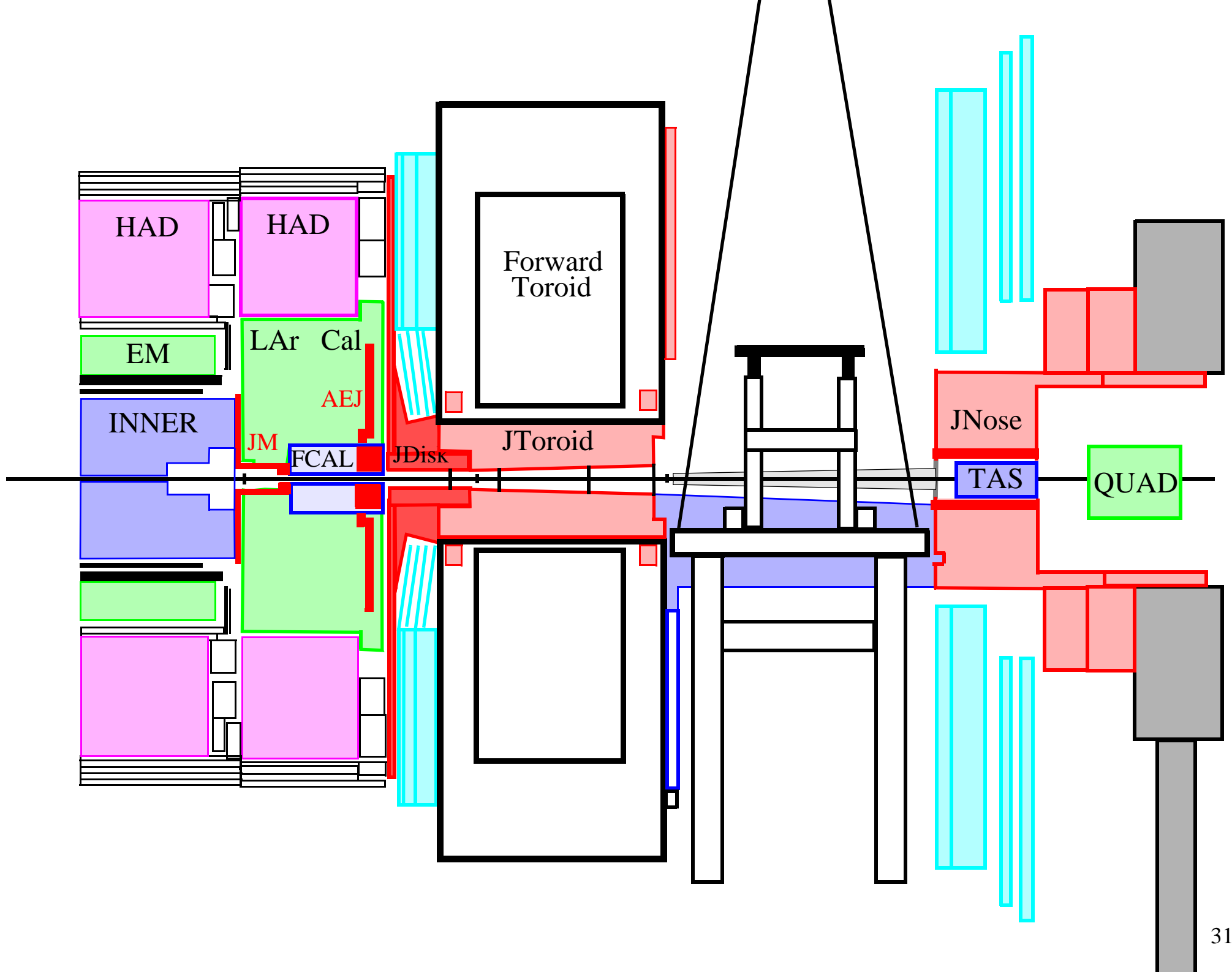

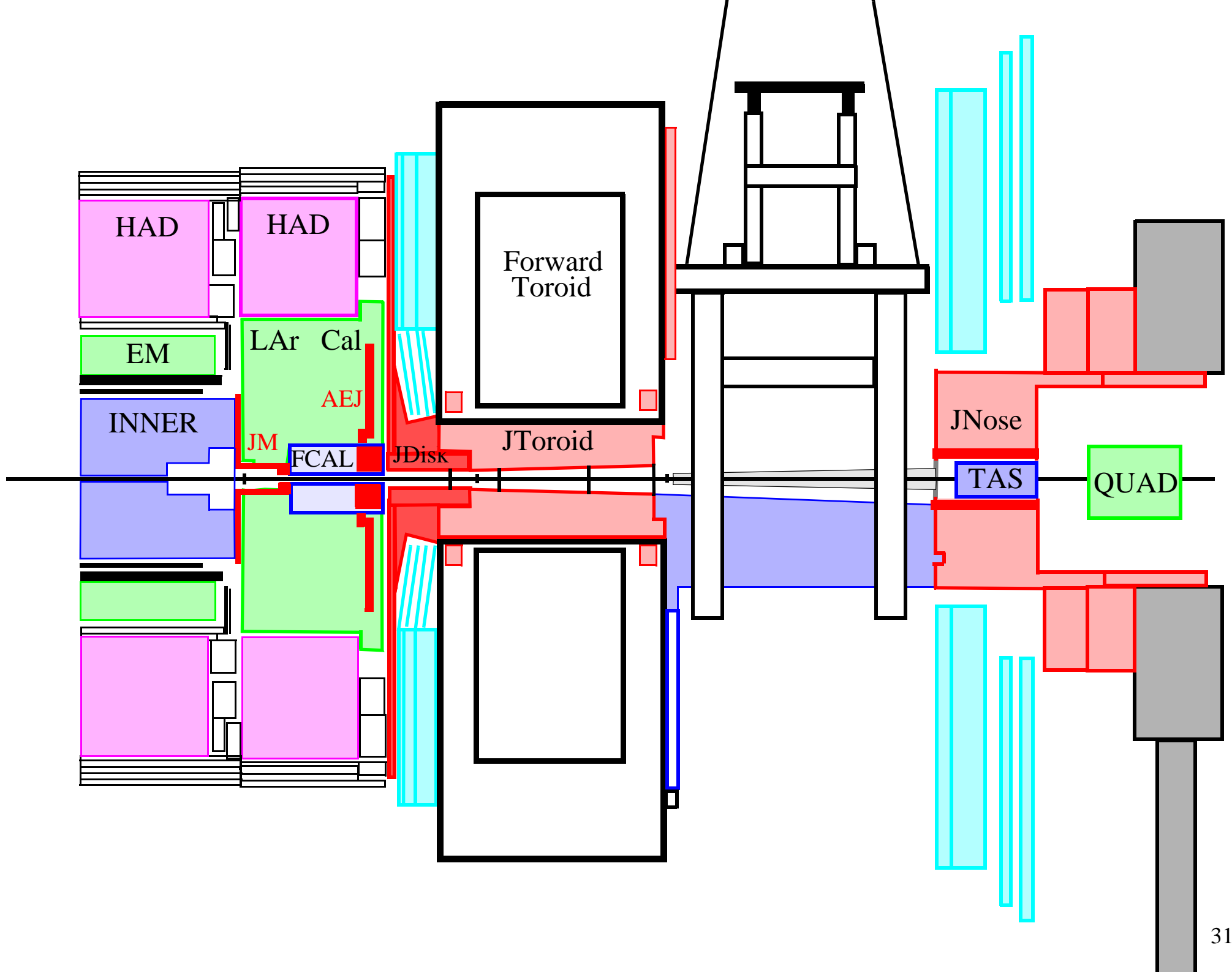

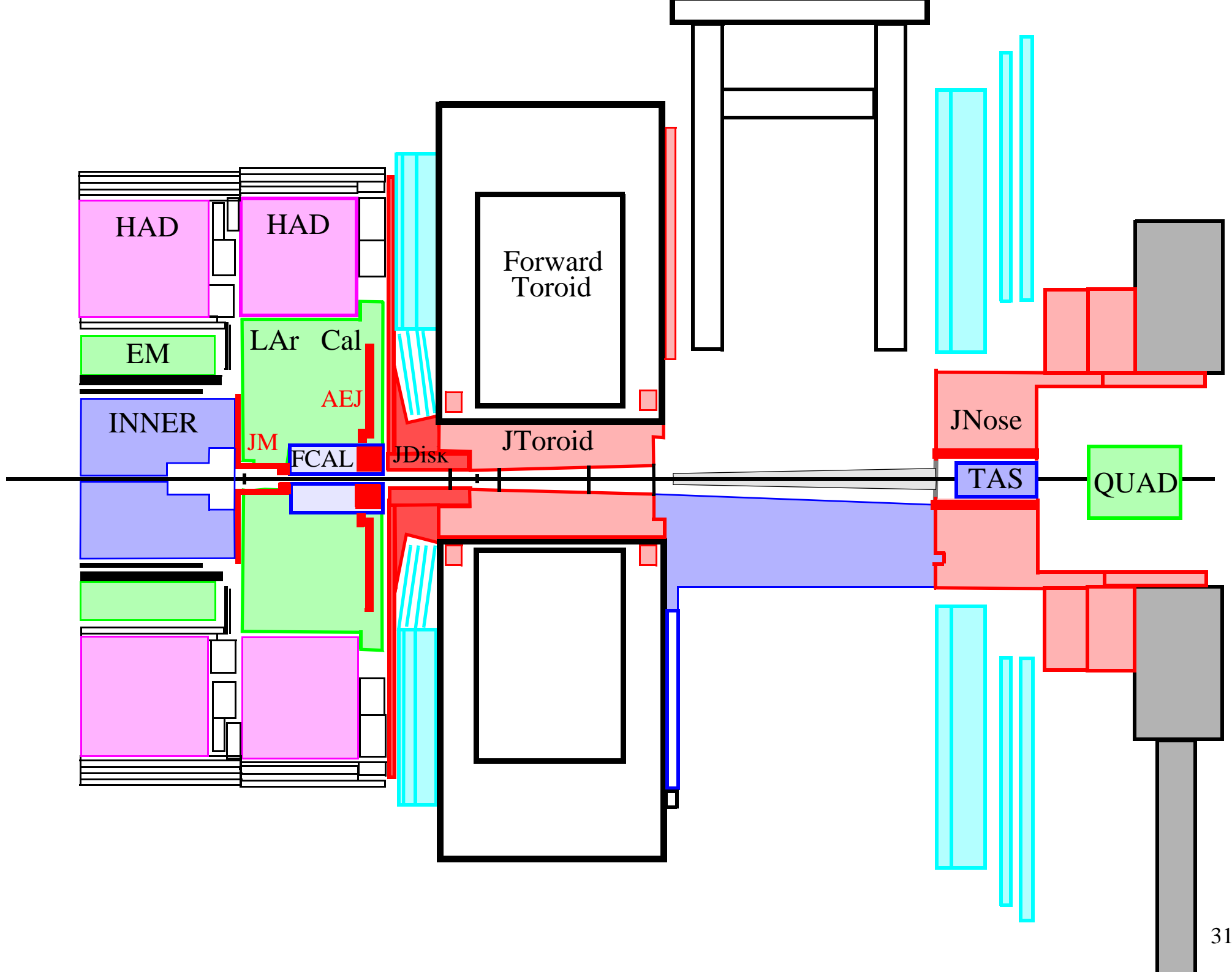

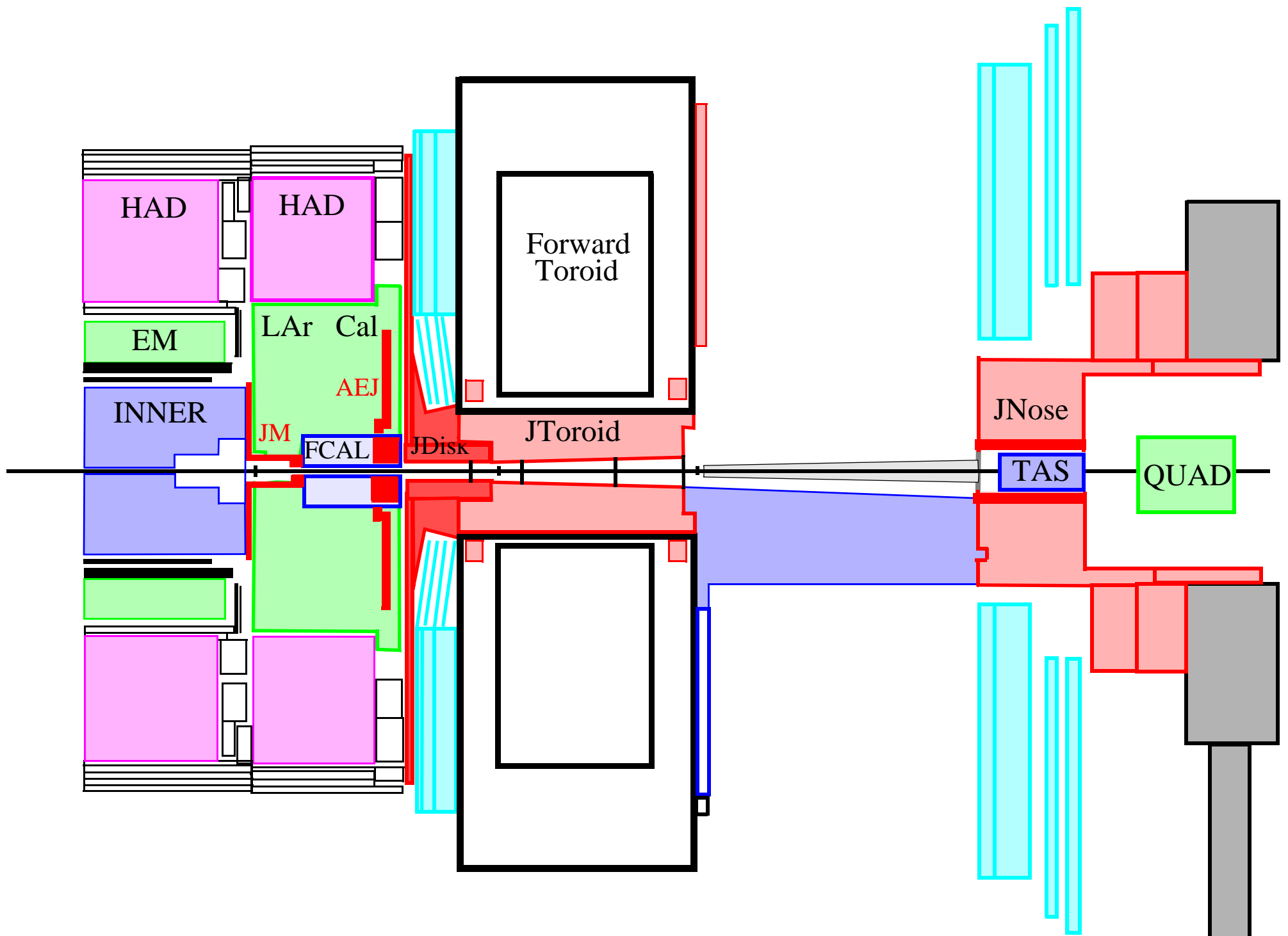

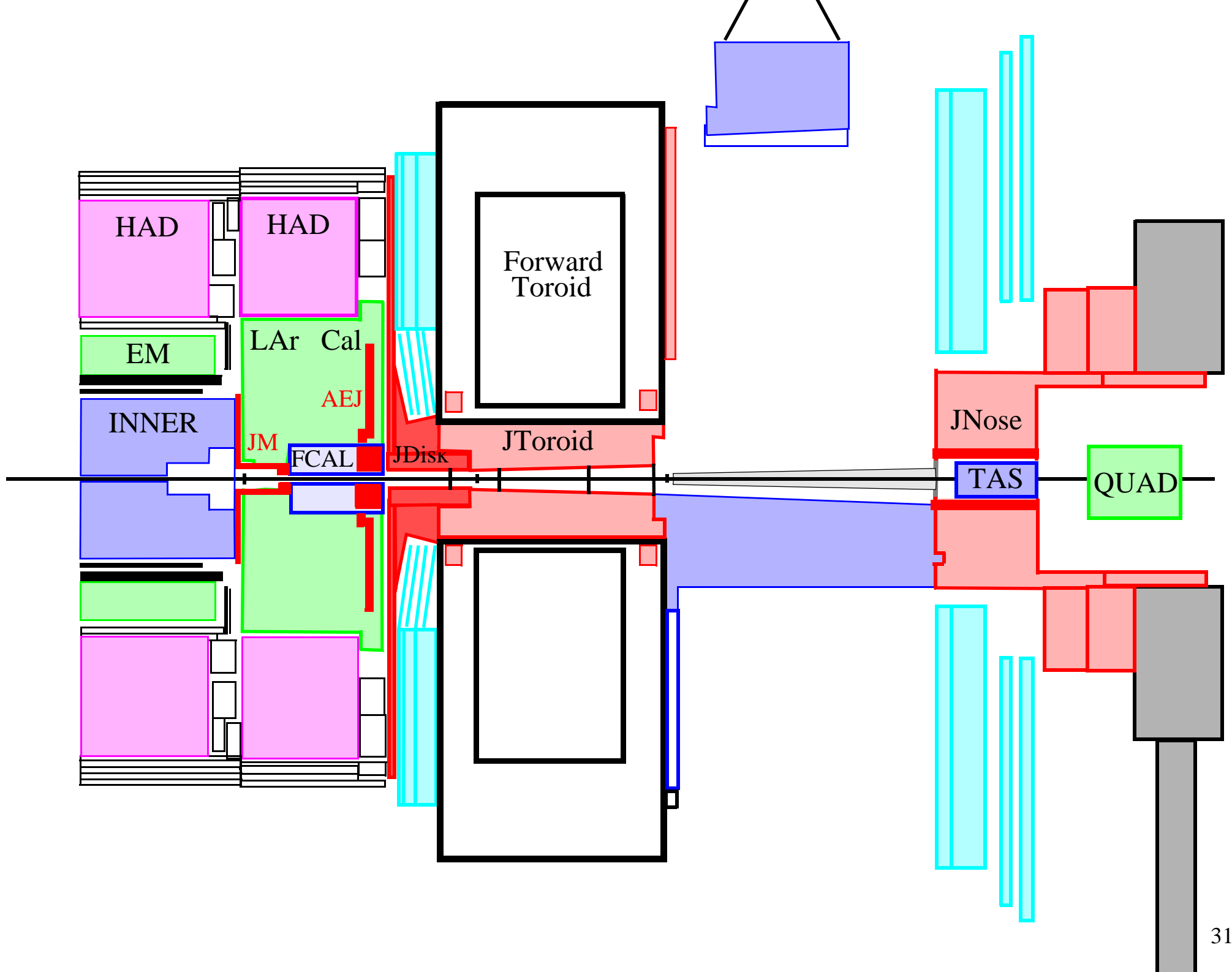

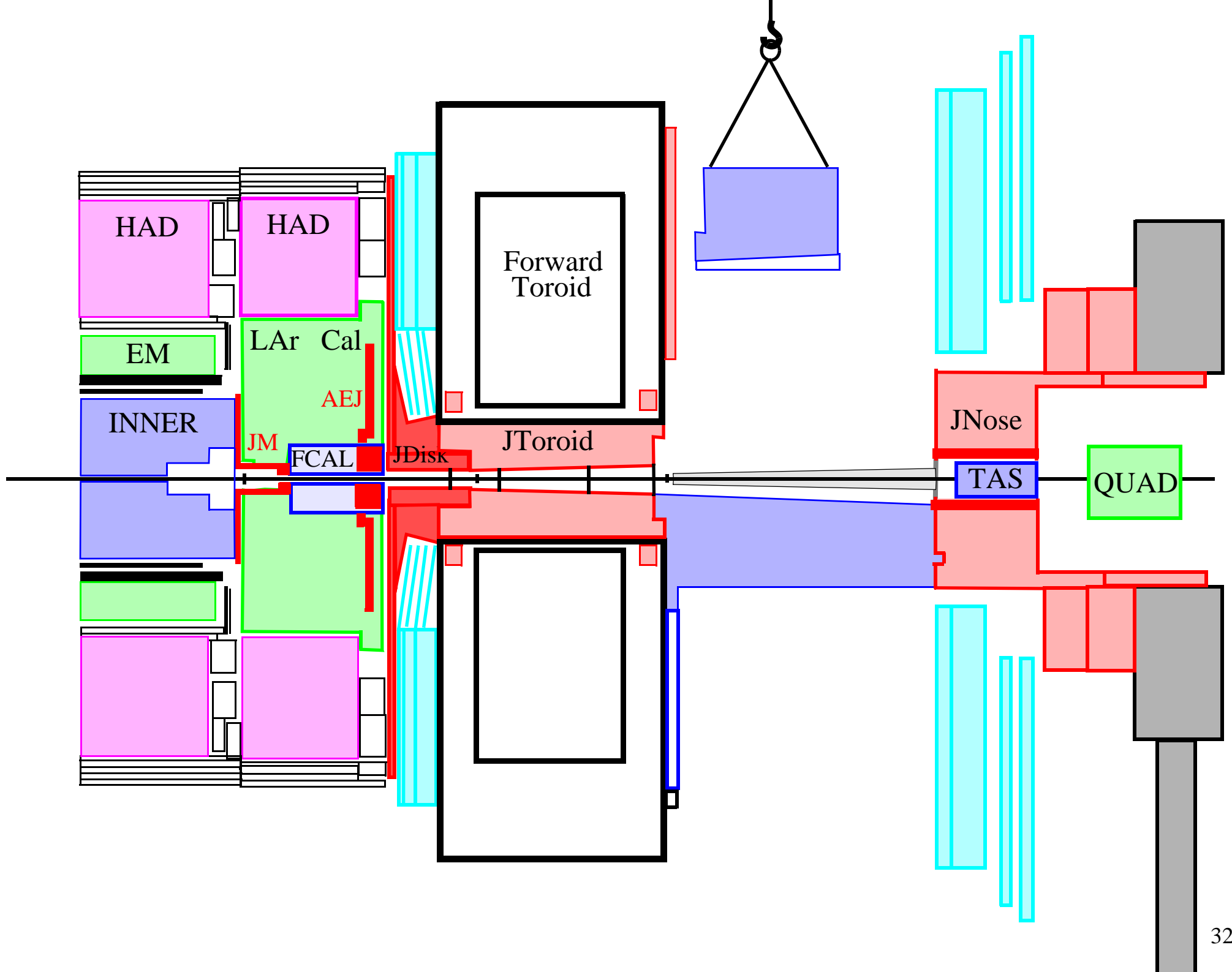

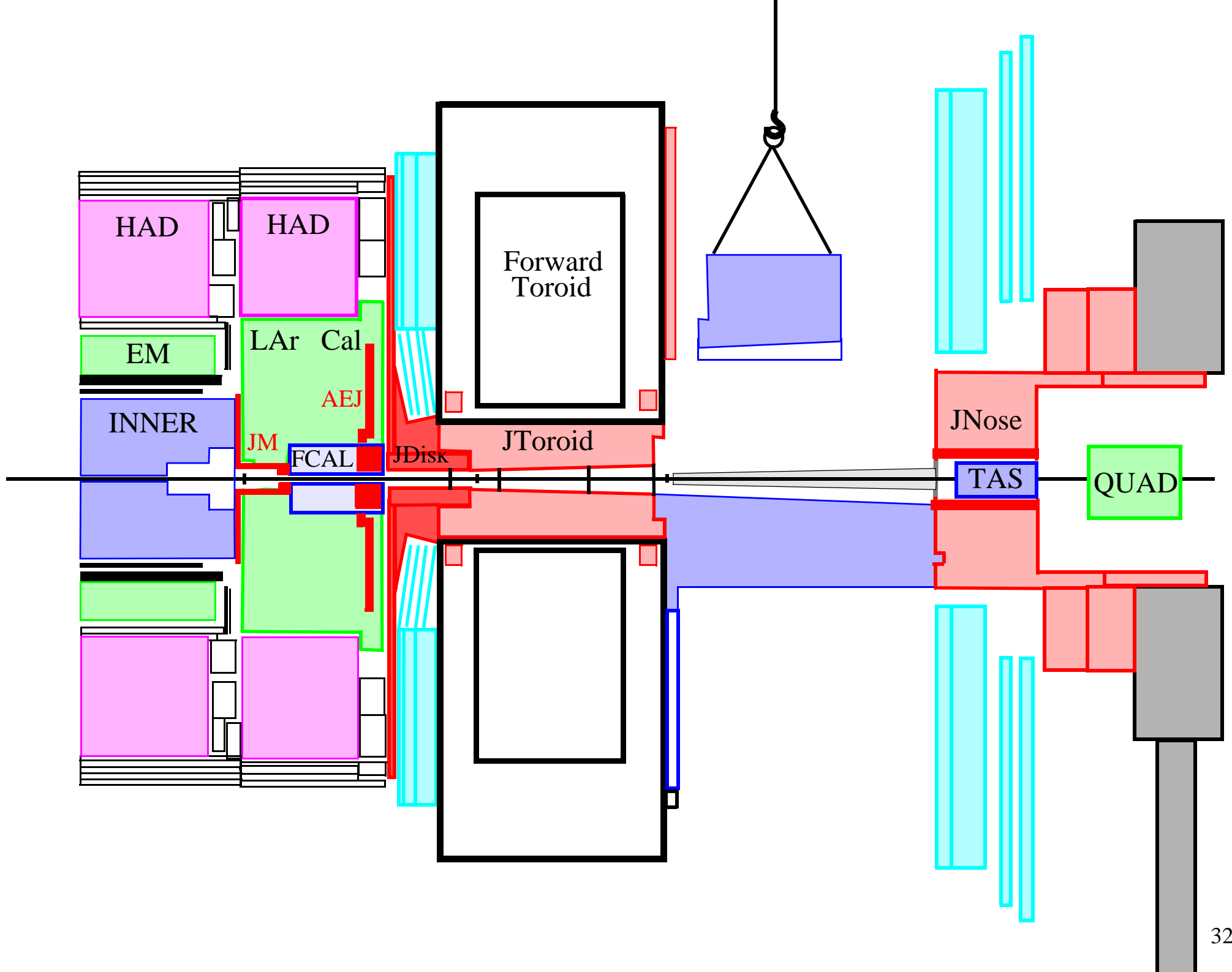

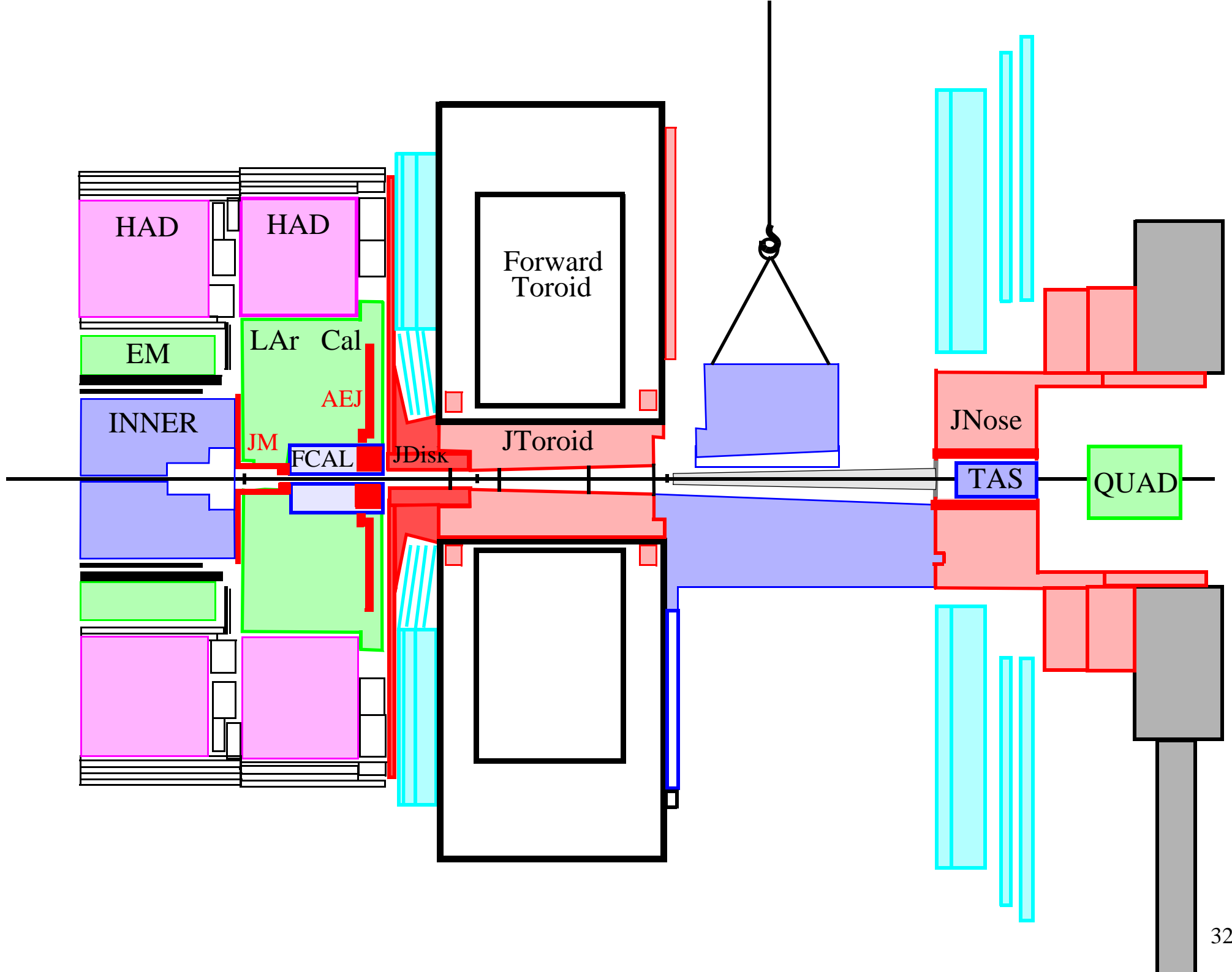

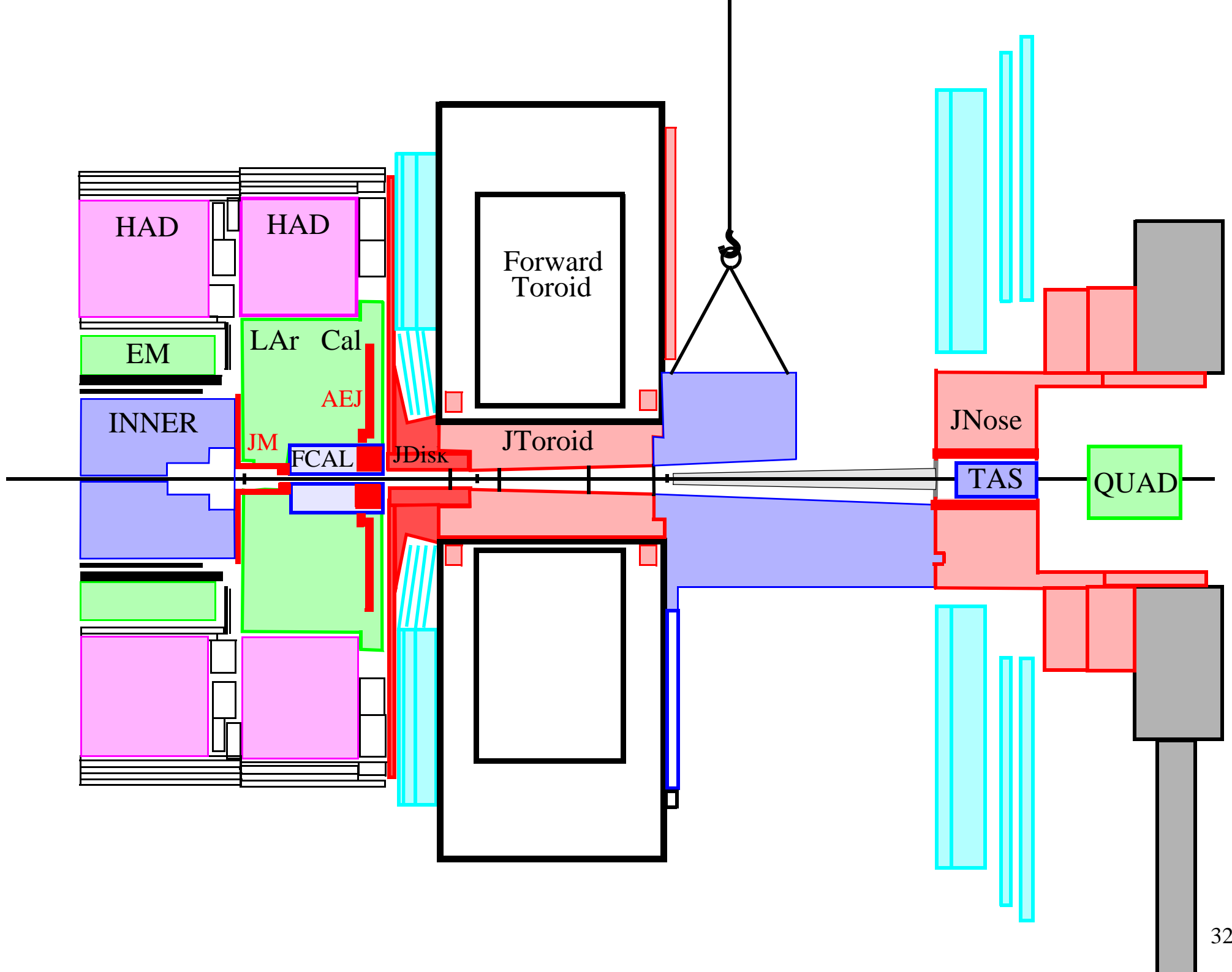

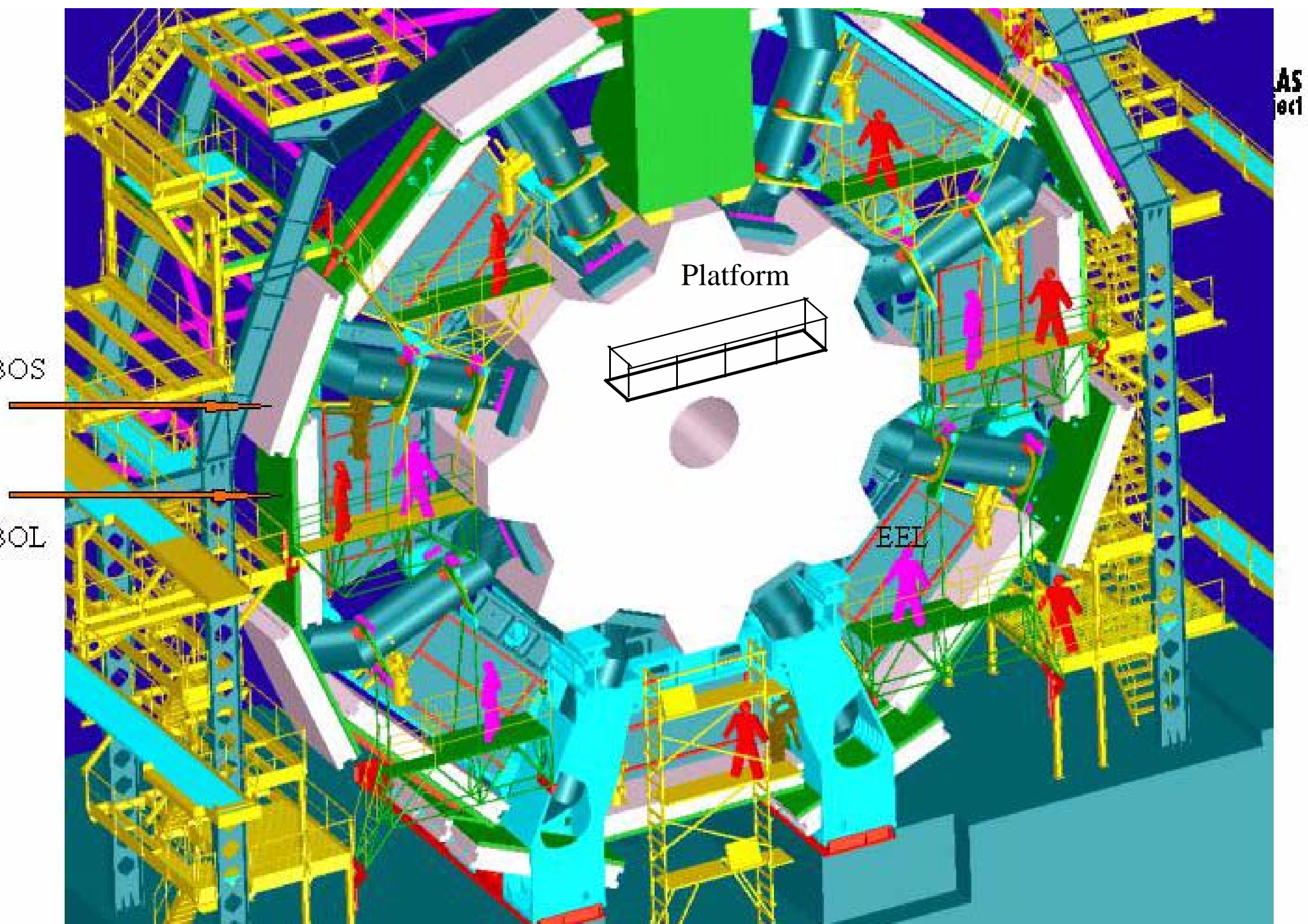

Platform

SOS

SOL

EEL

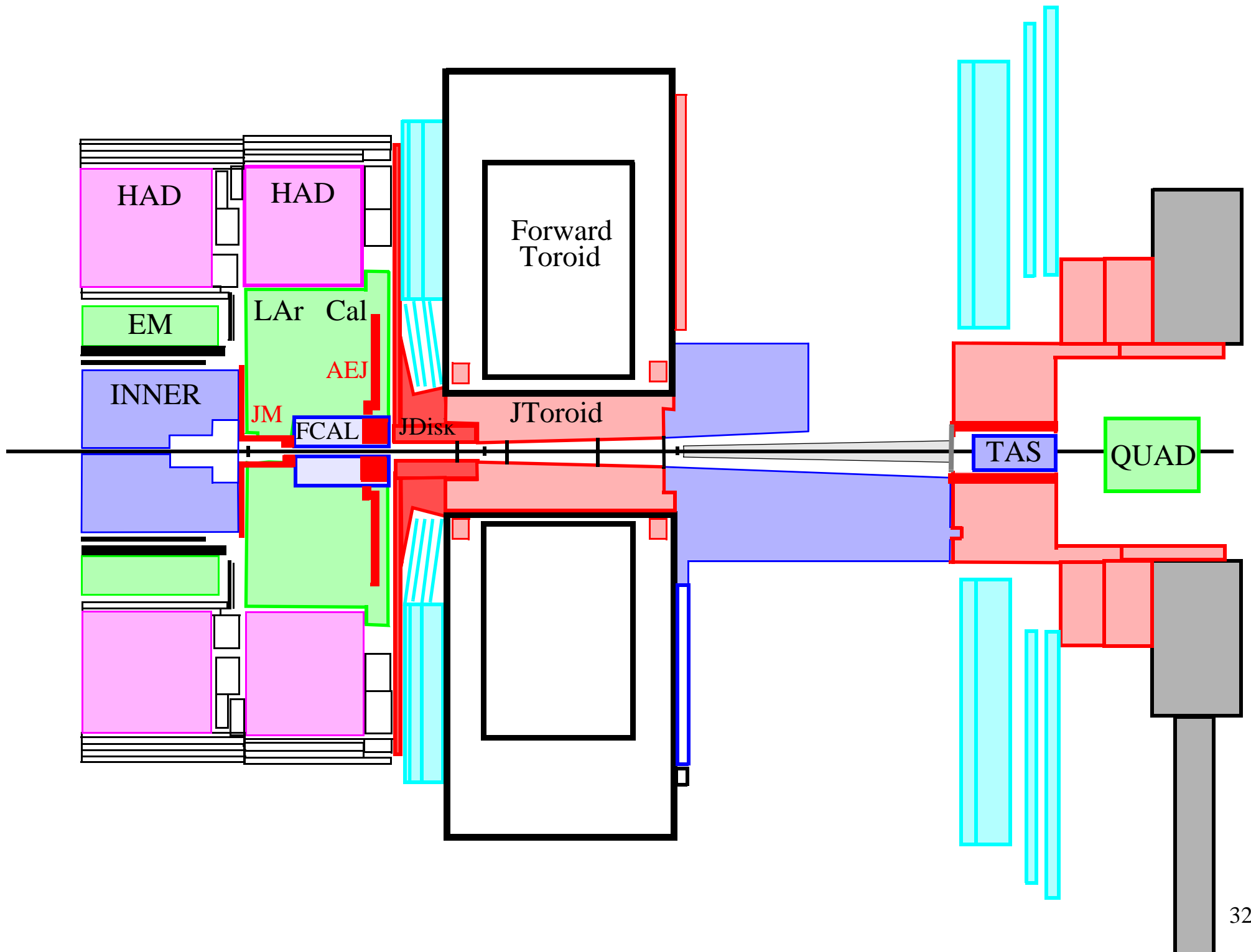

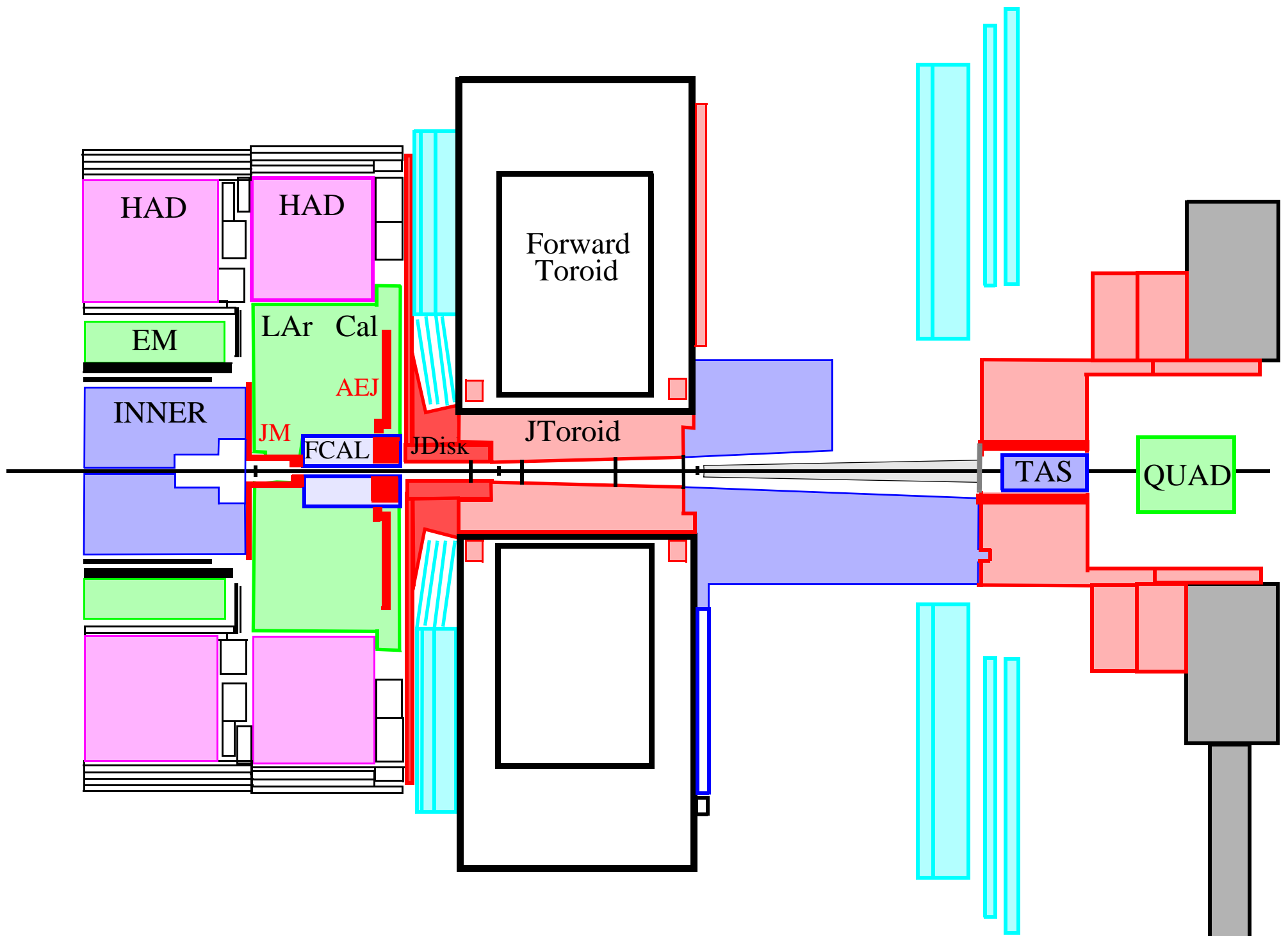

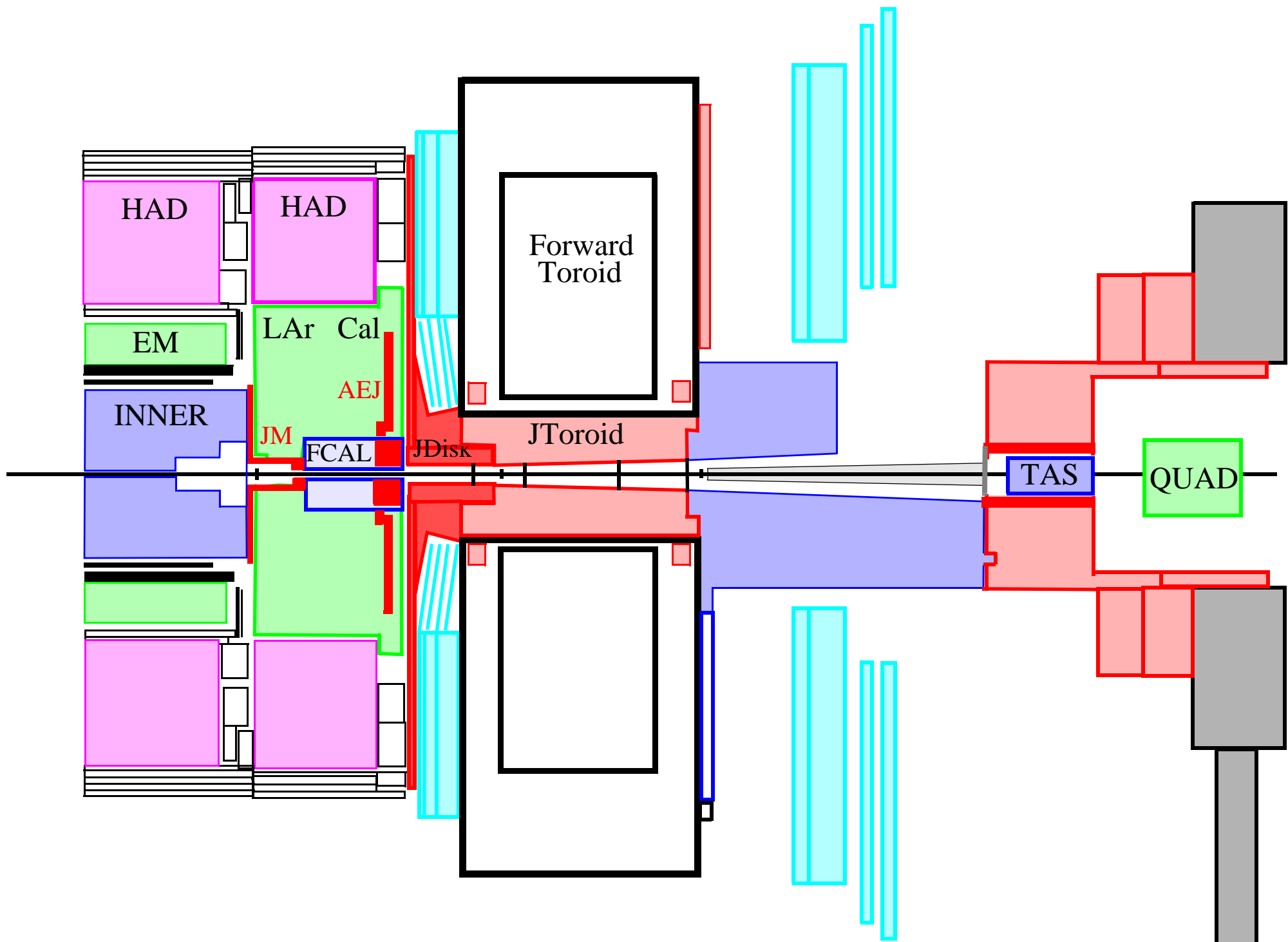

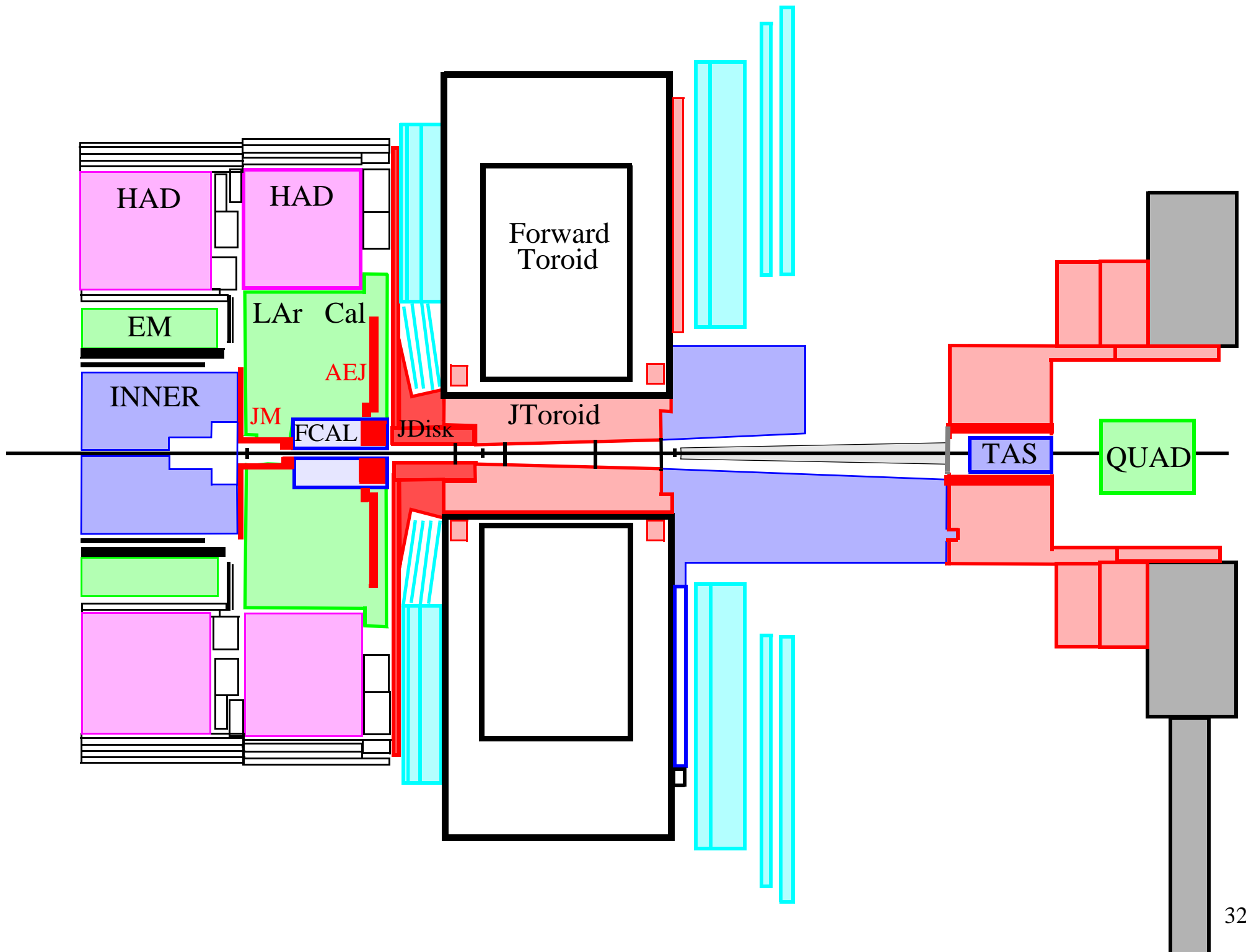

July 2007

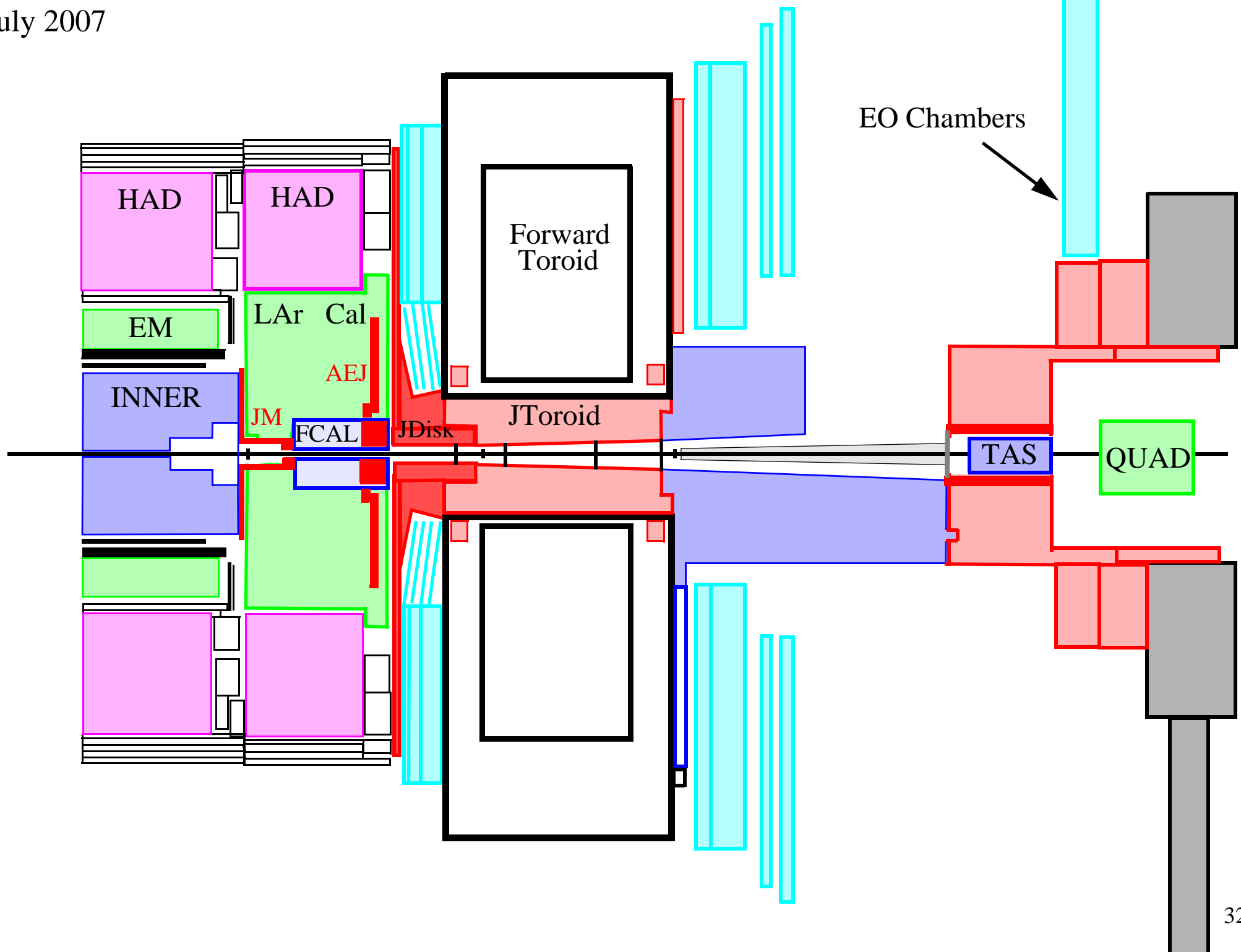

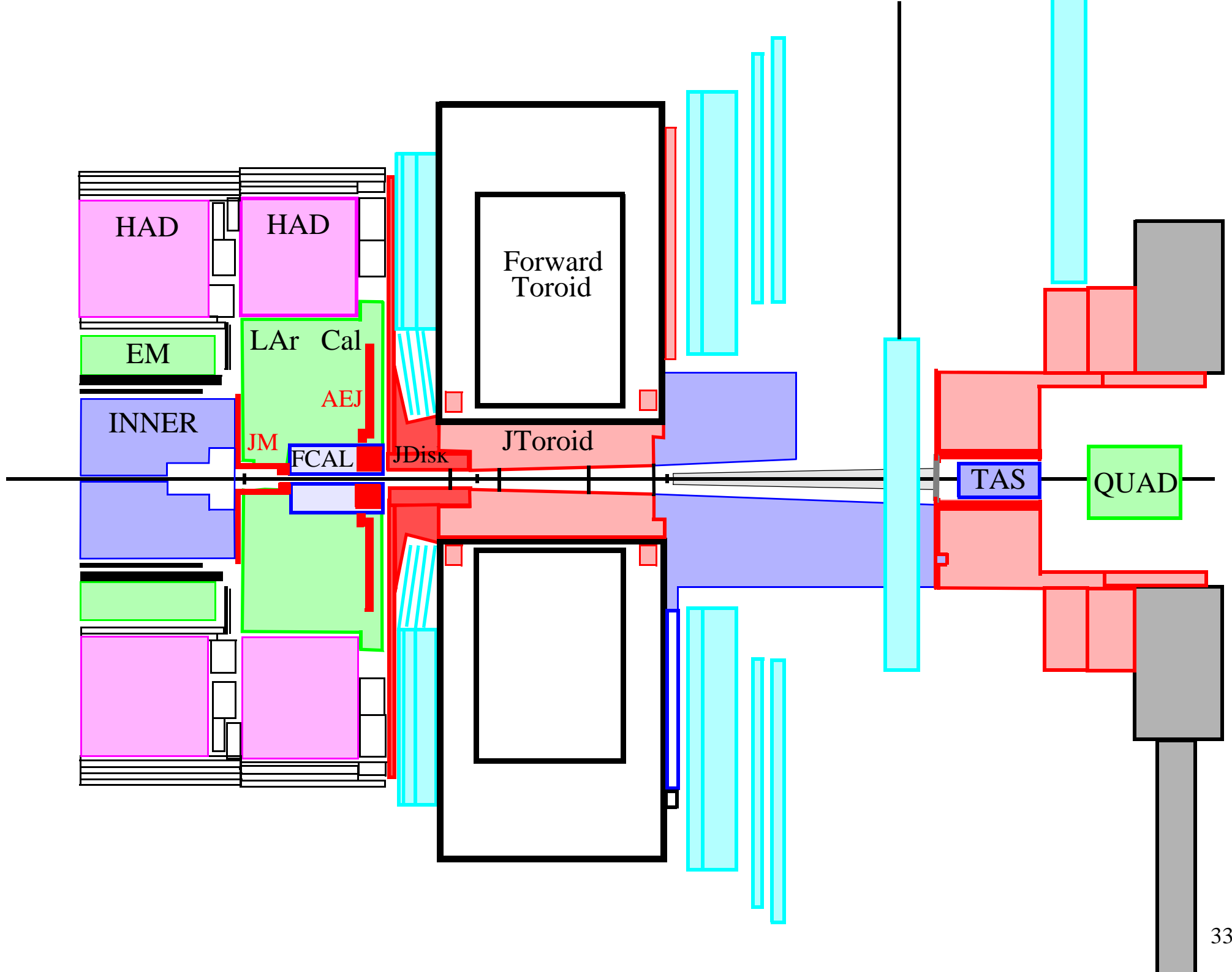

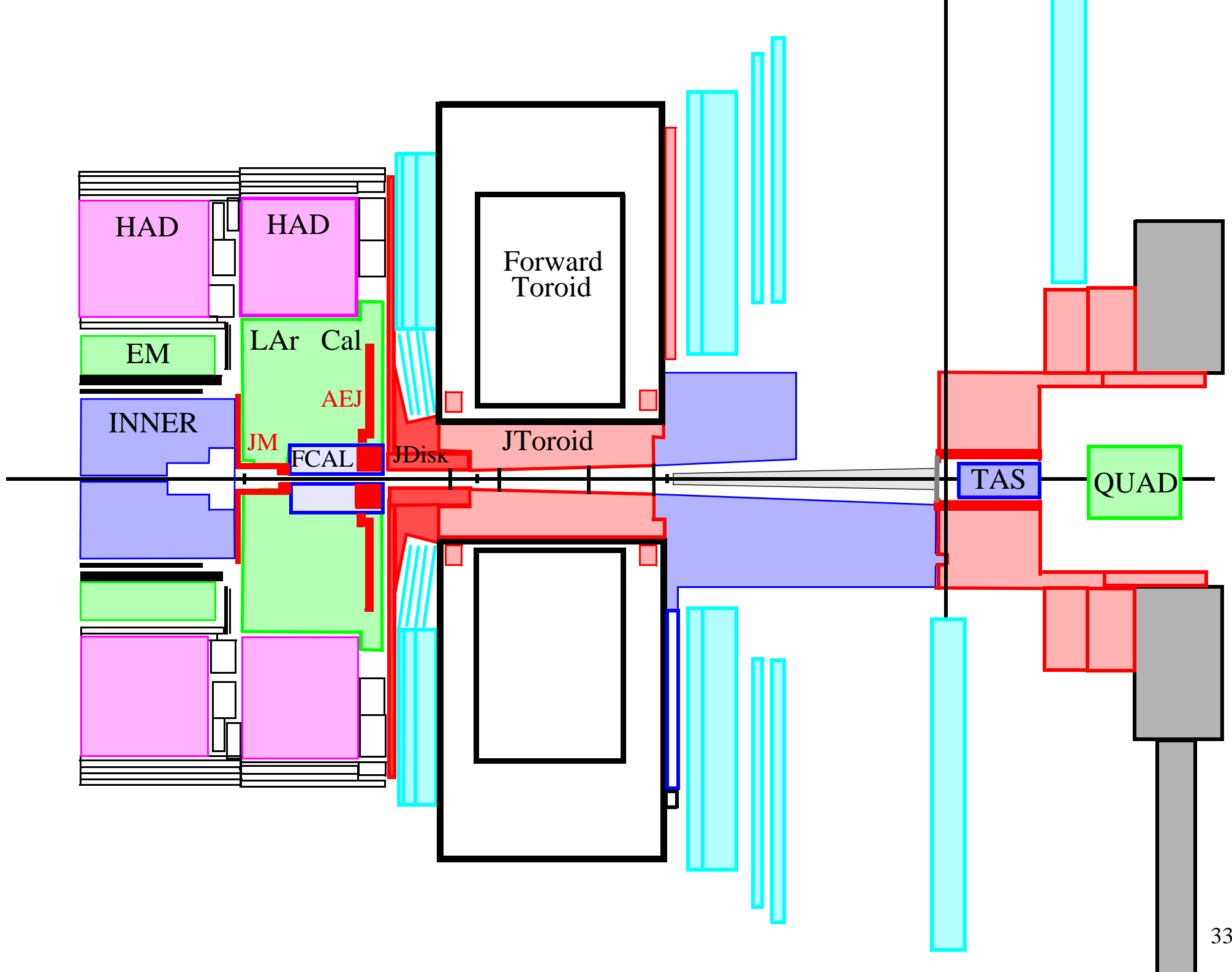

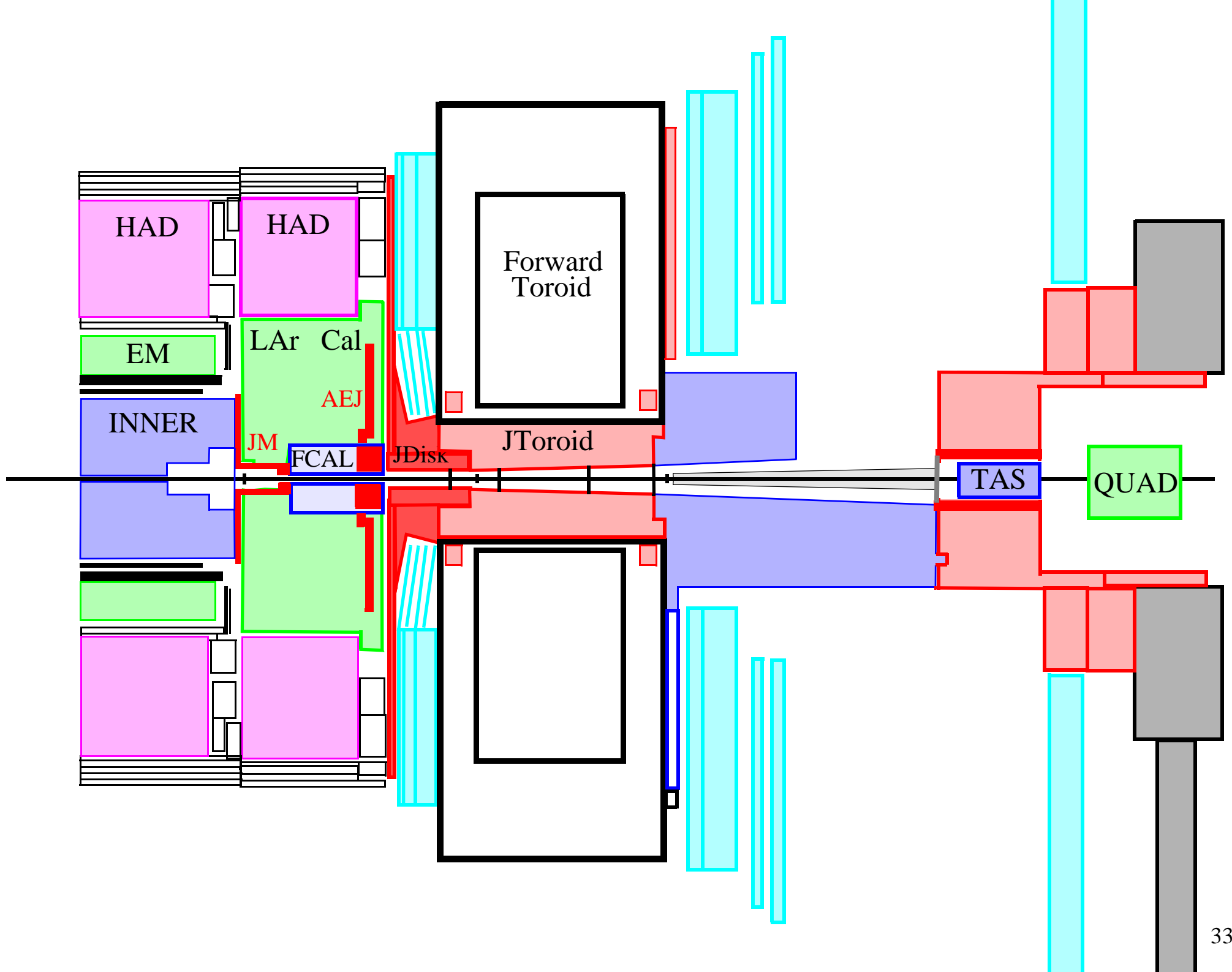

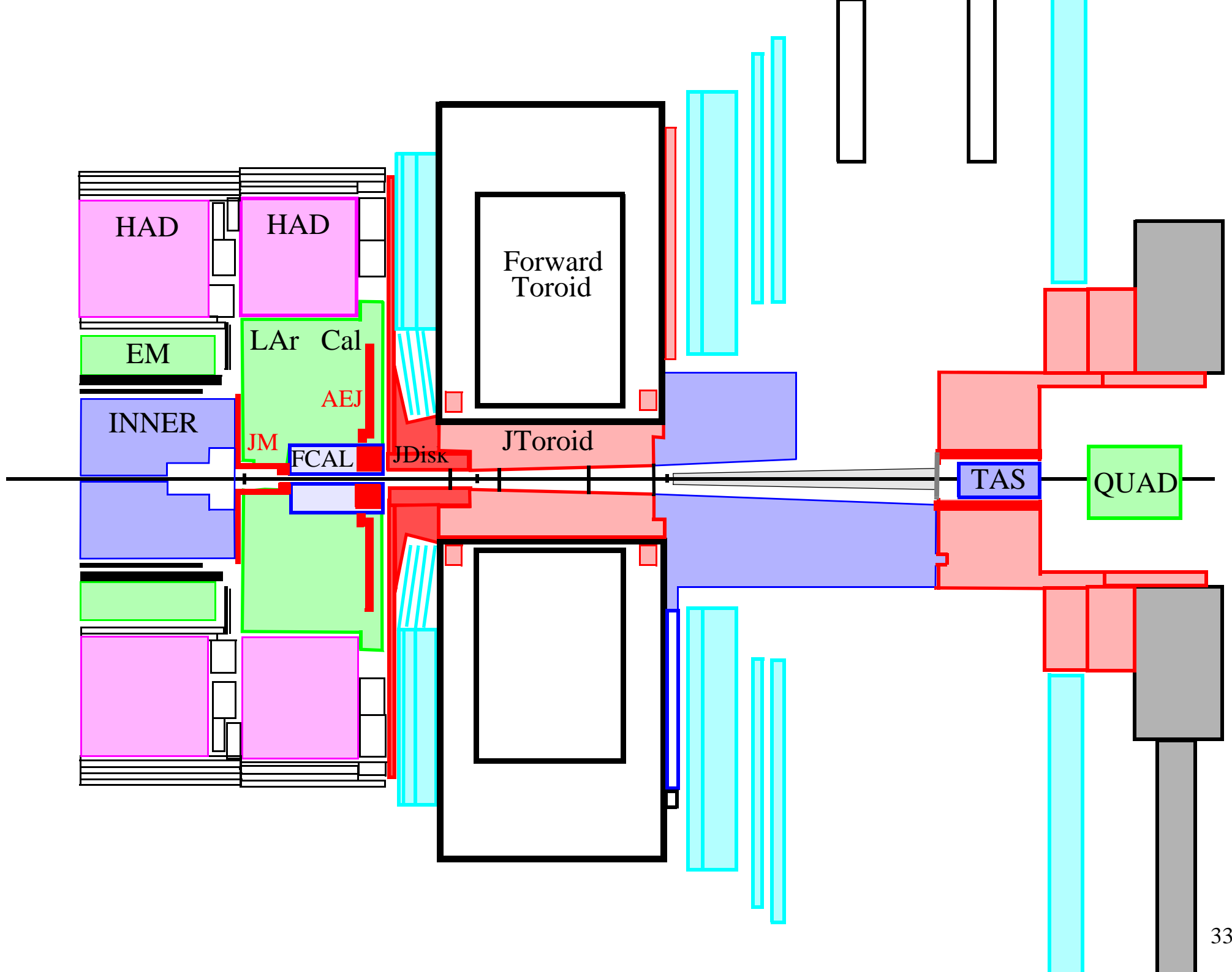

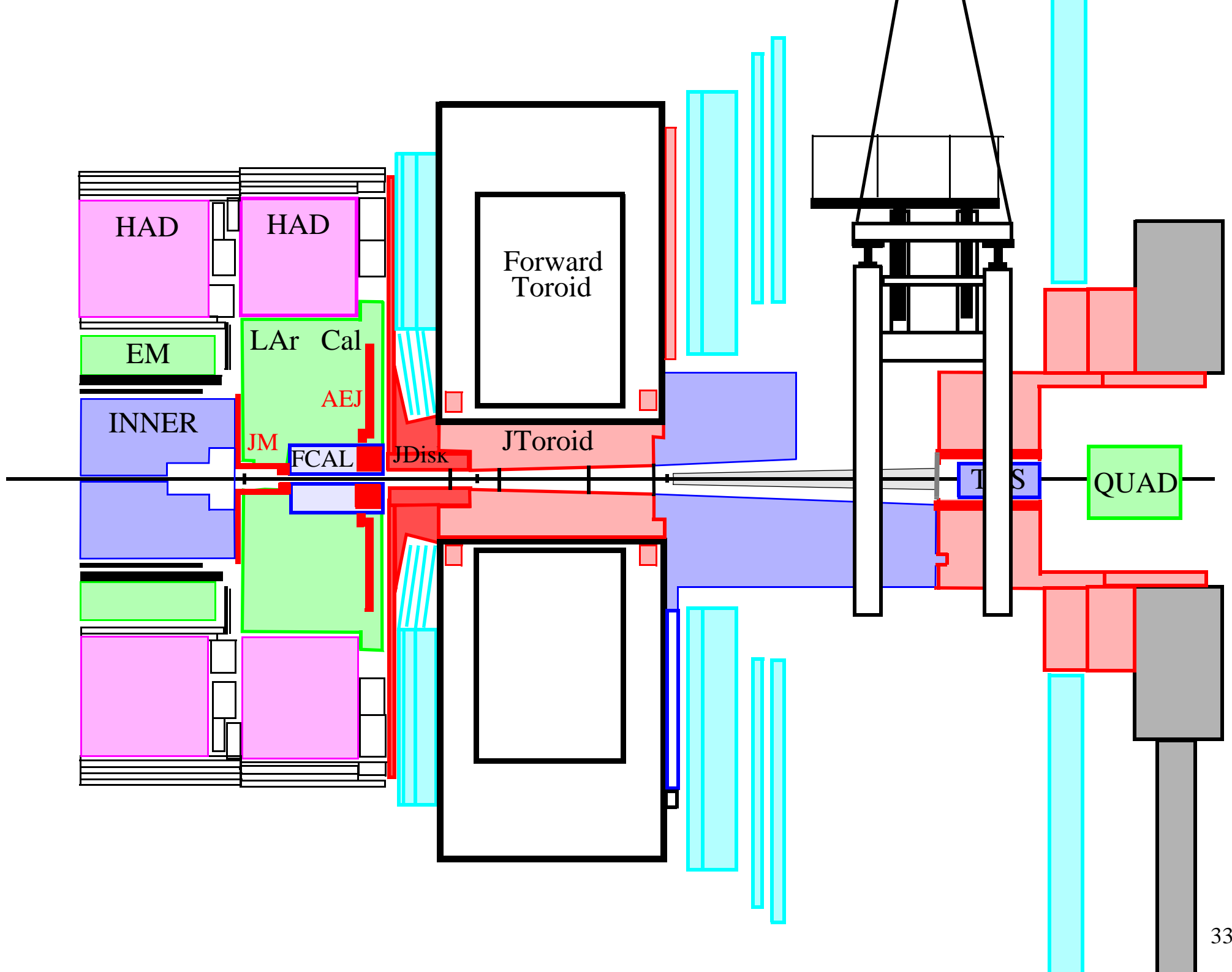

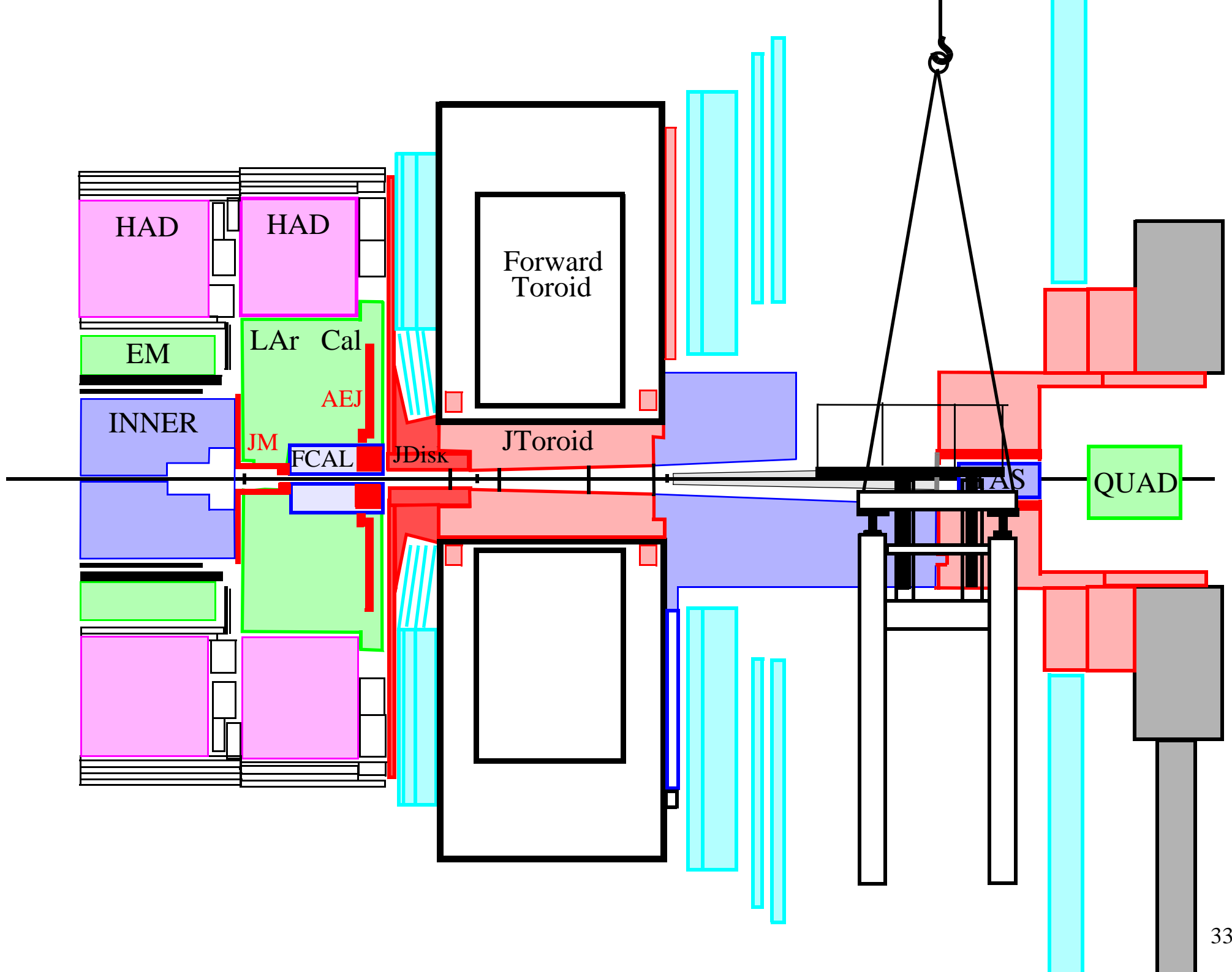

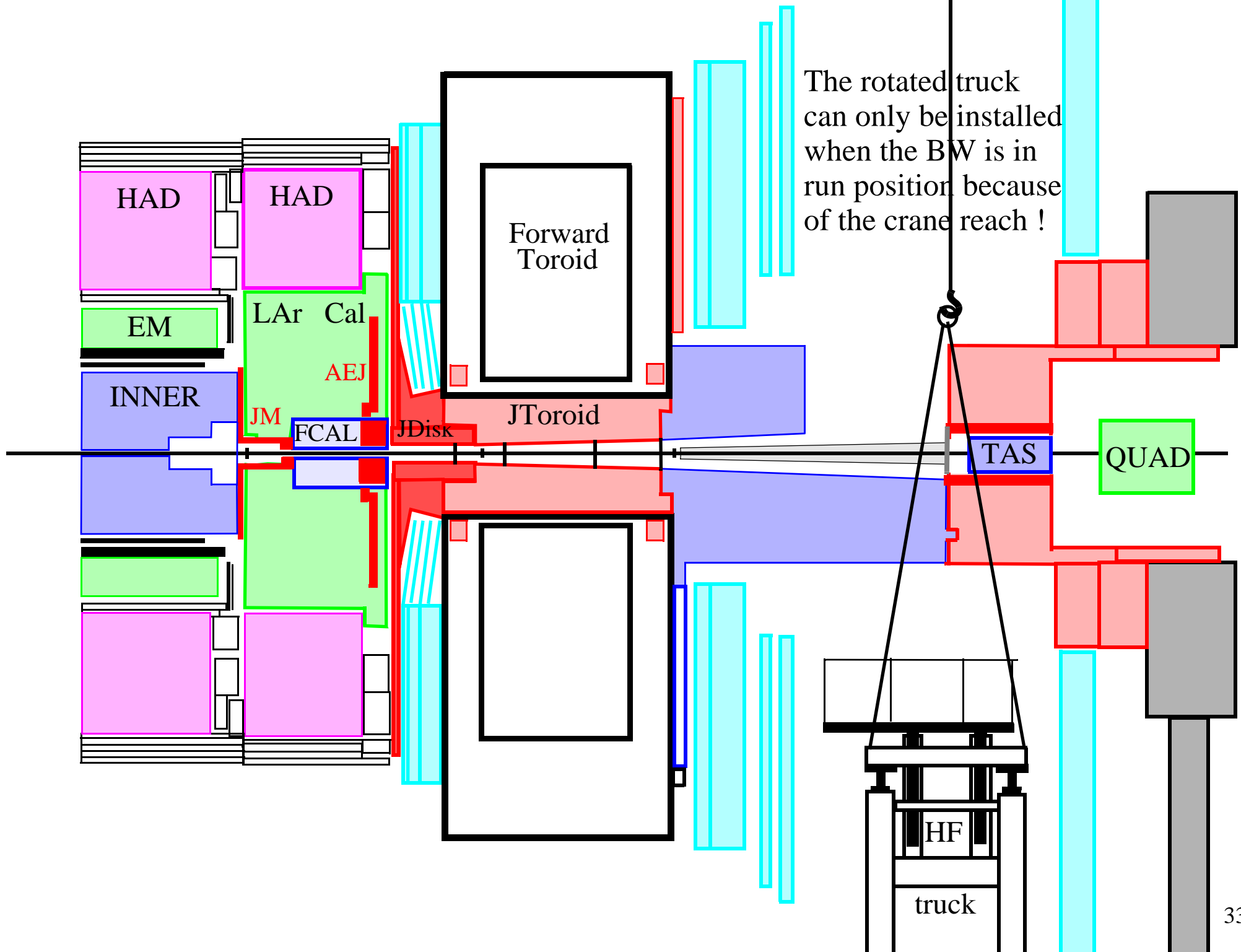

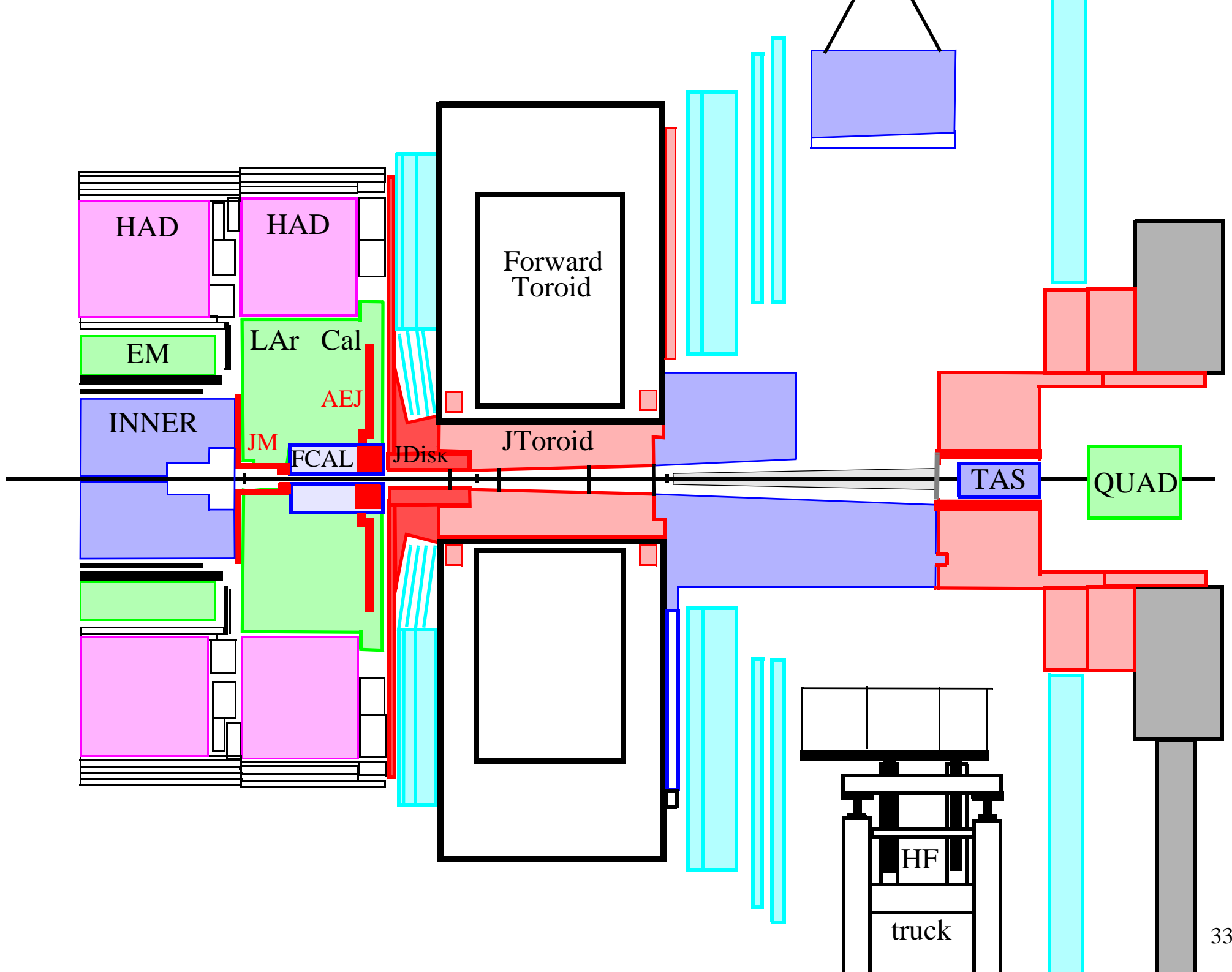

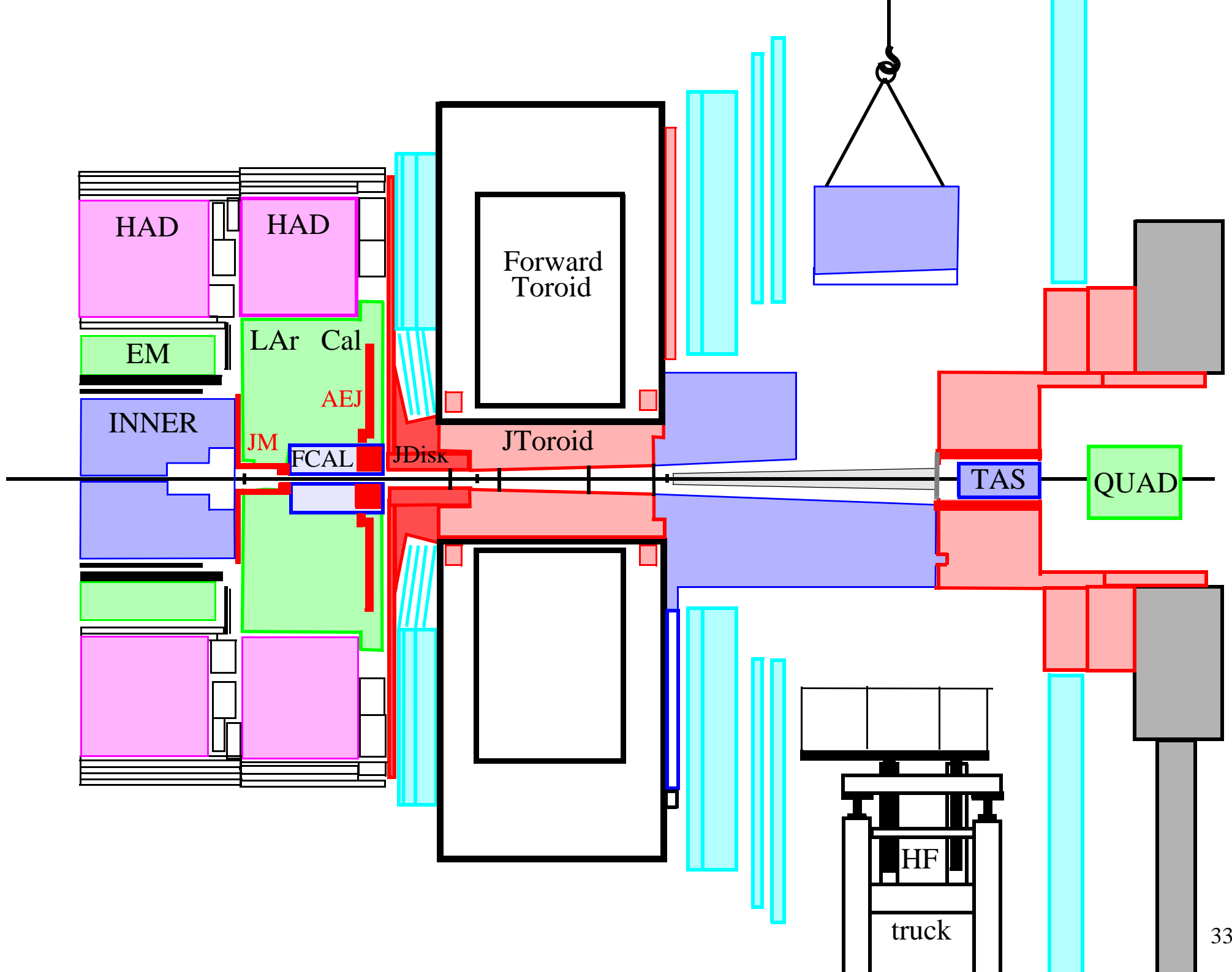

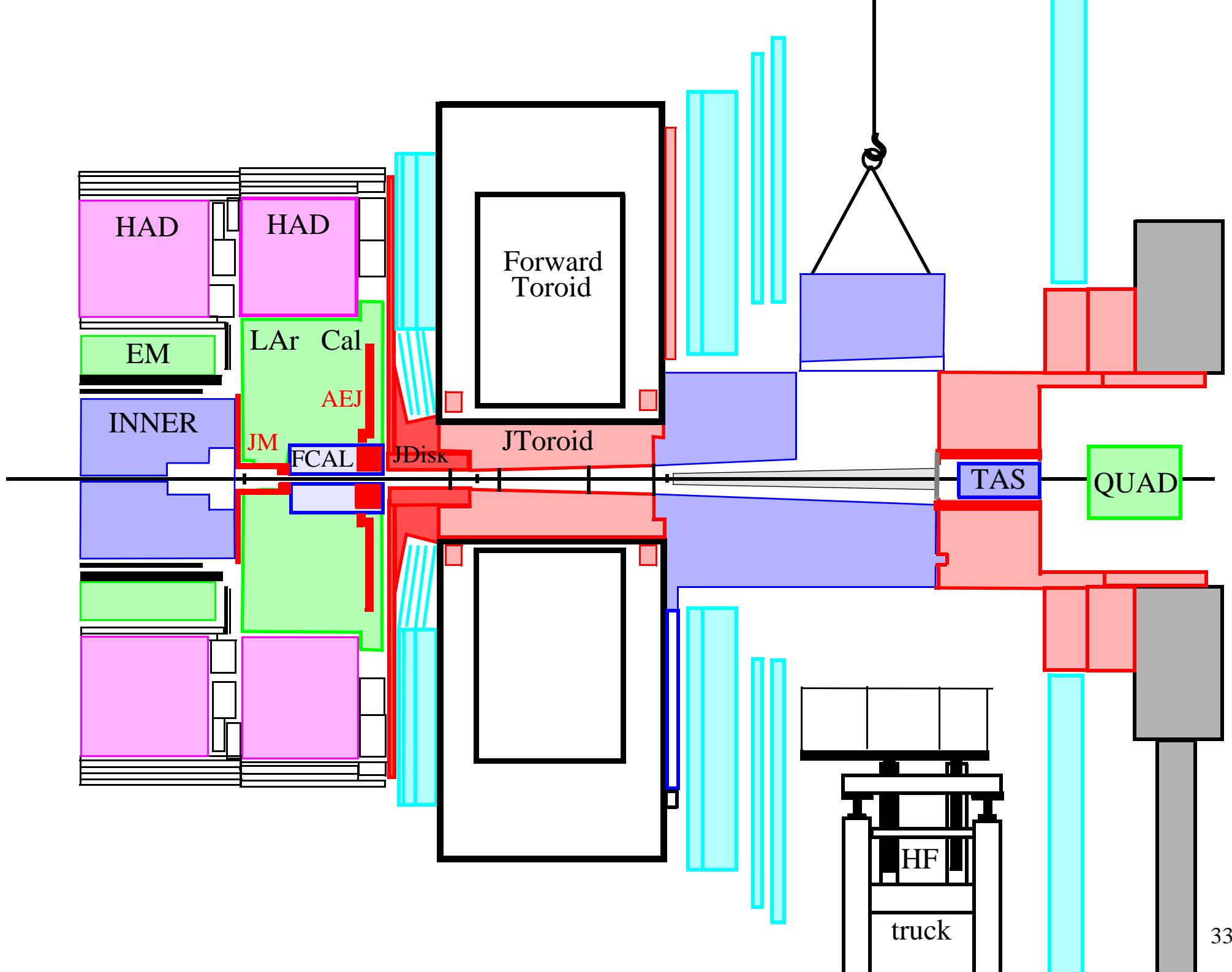

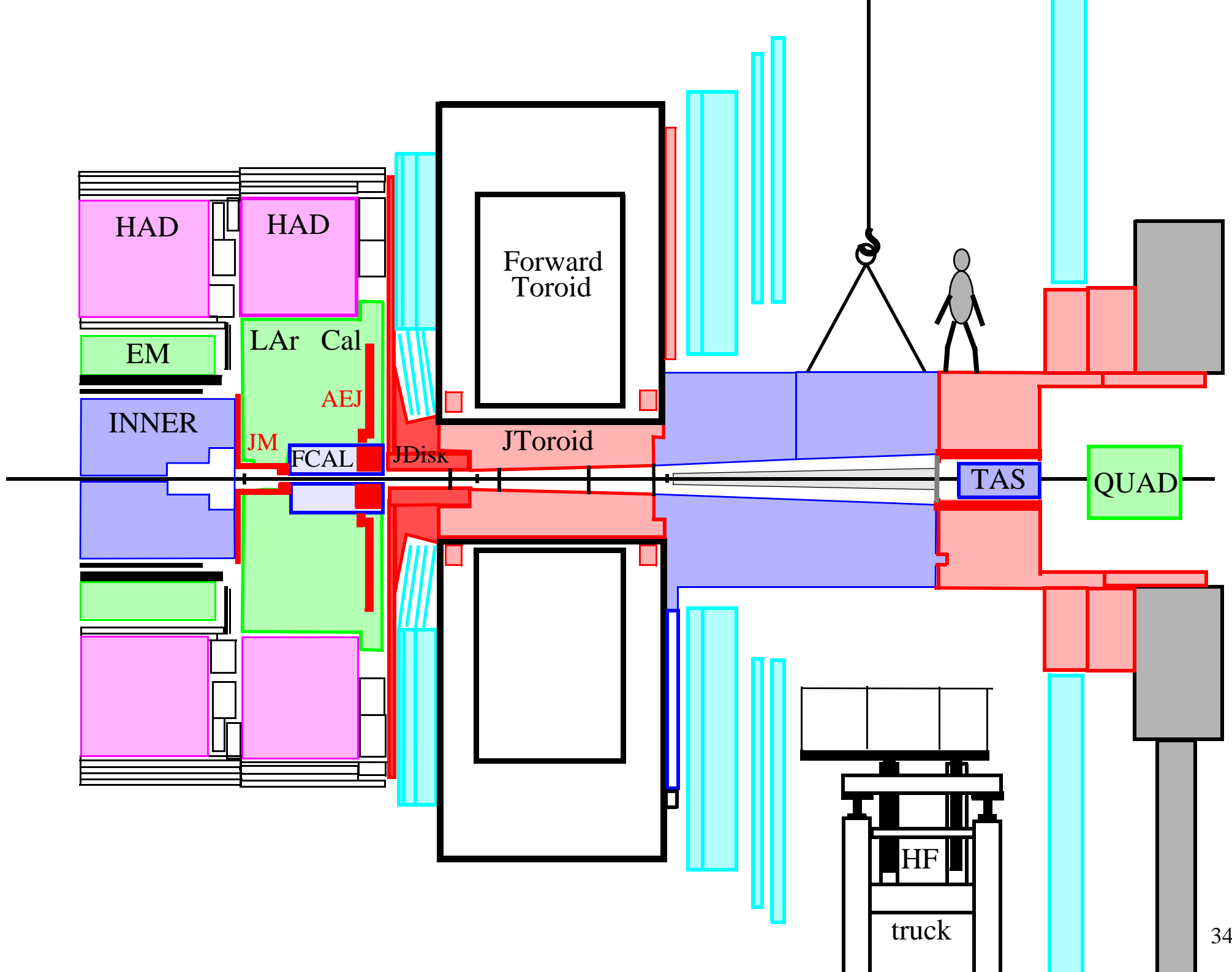

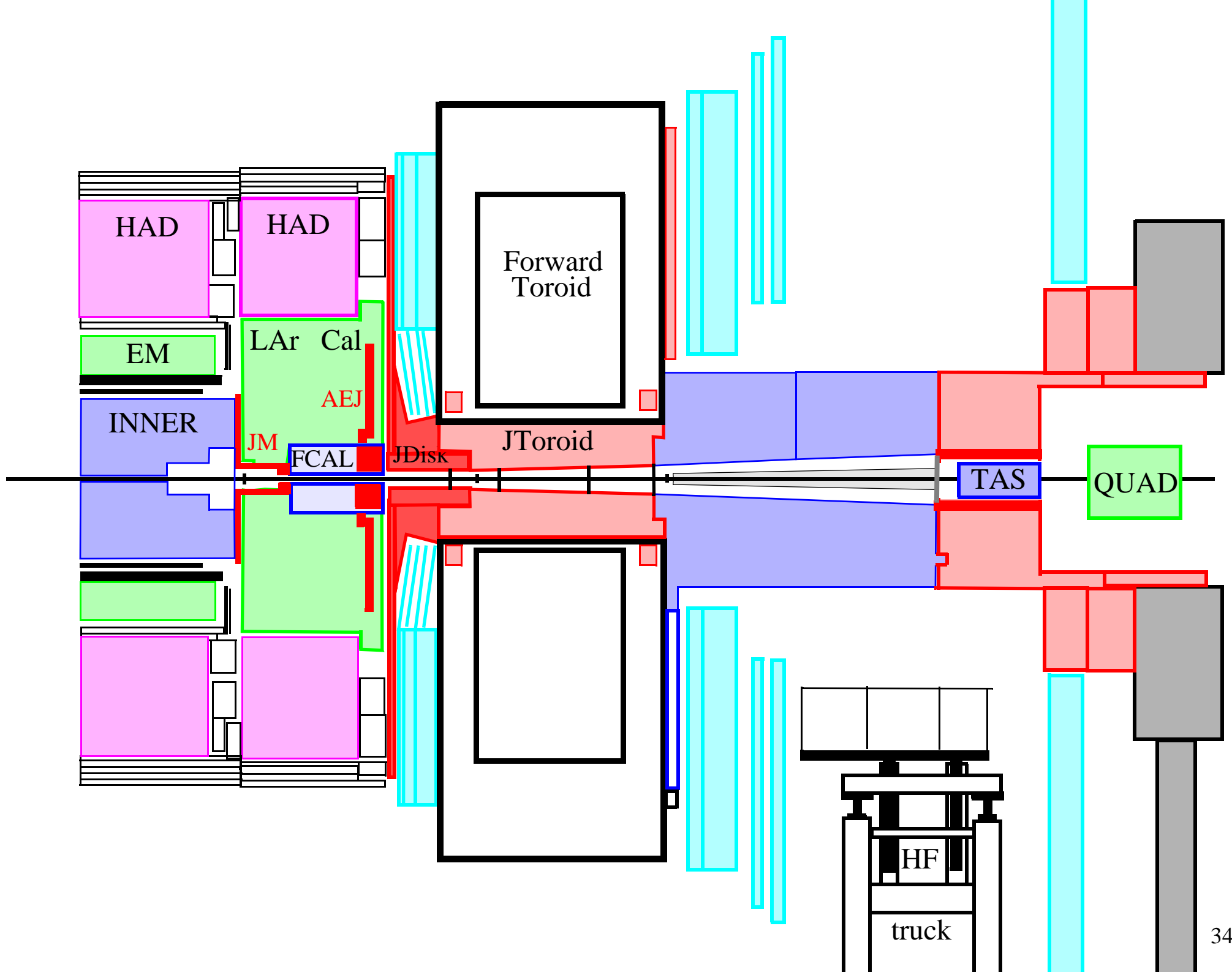

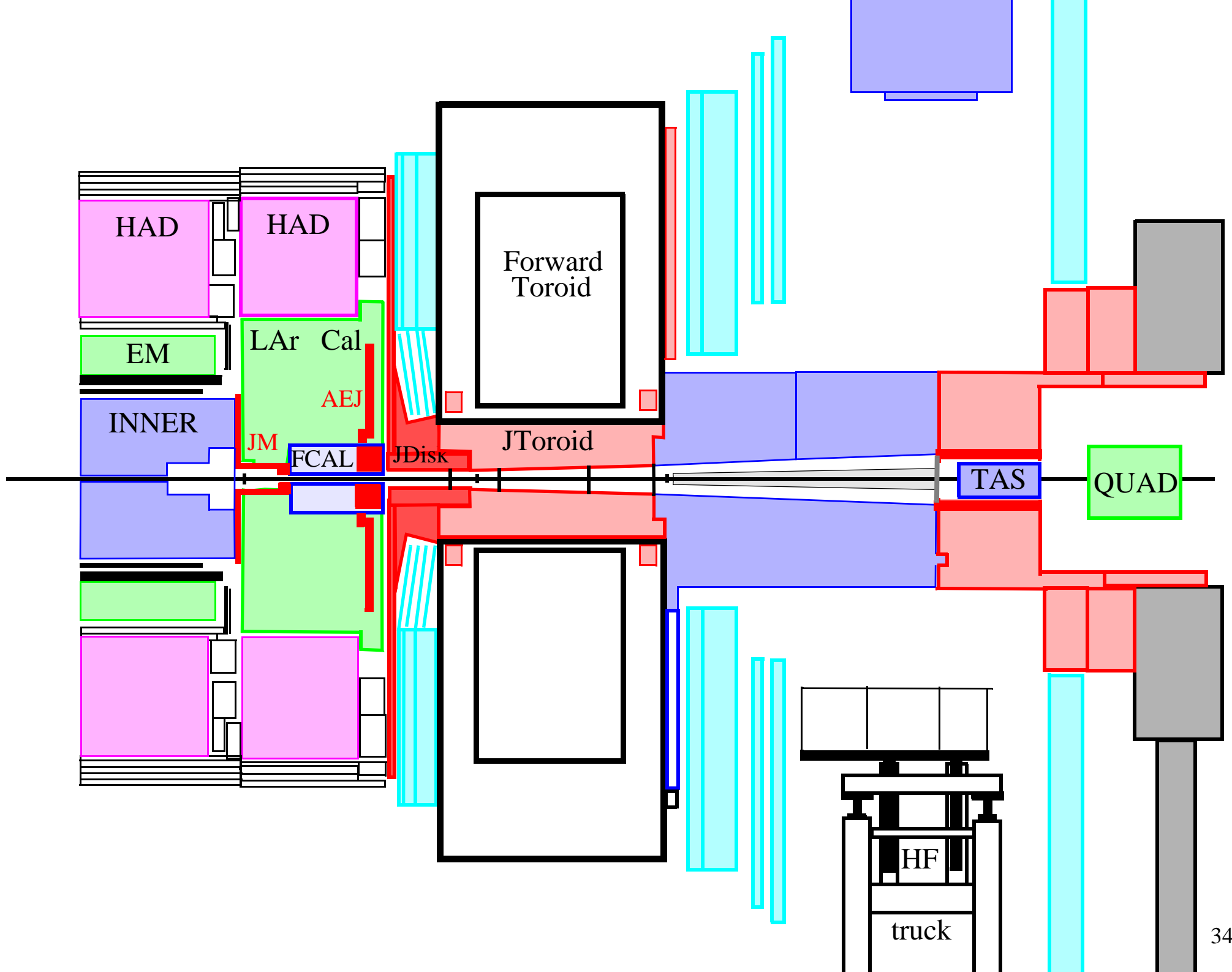

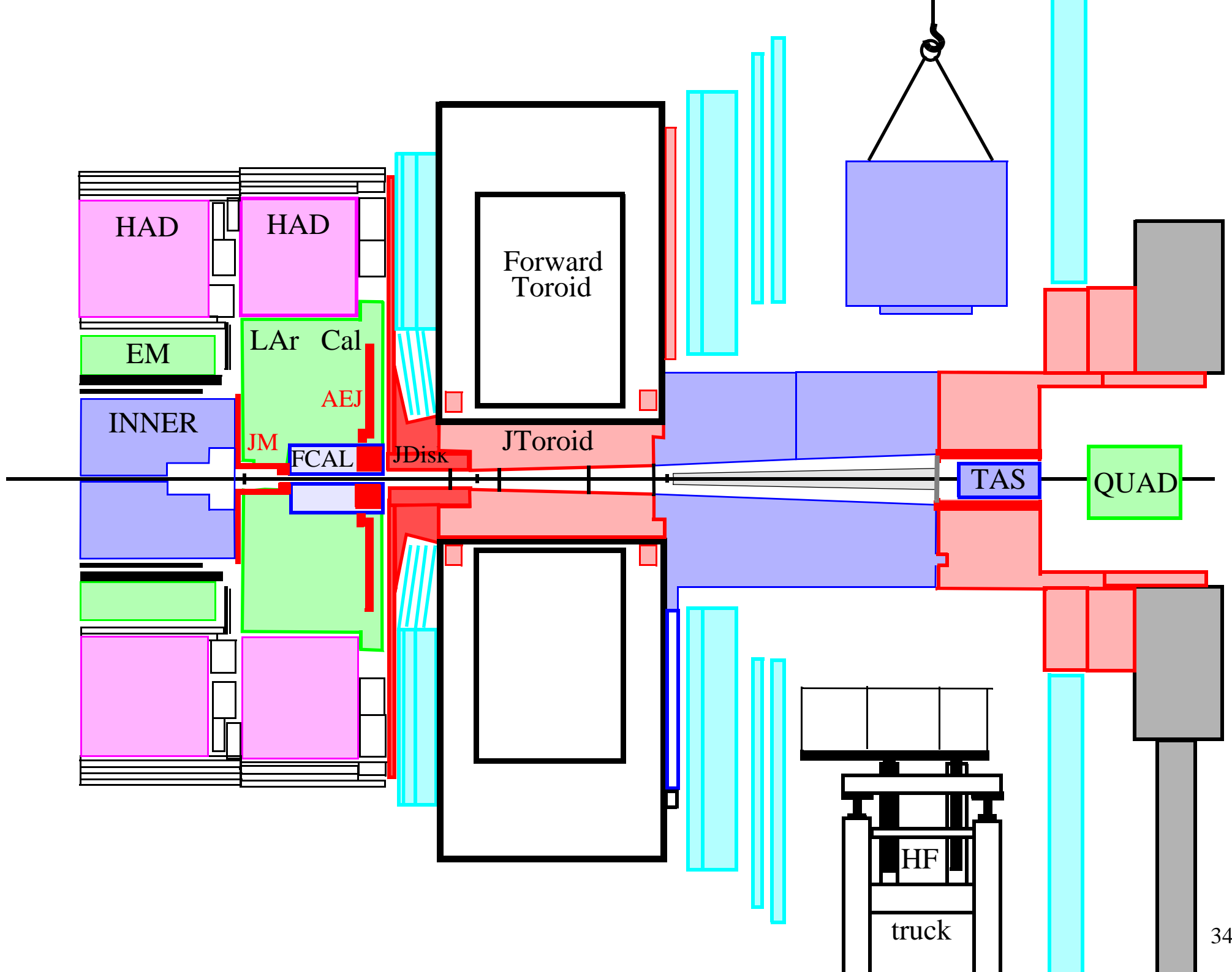

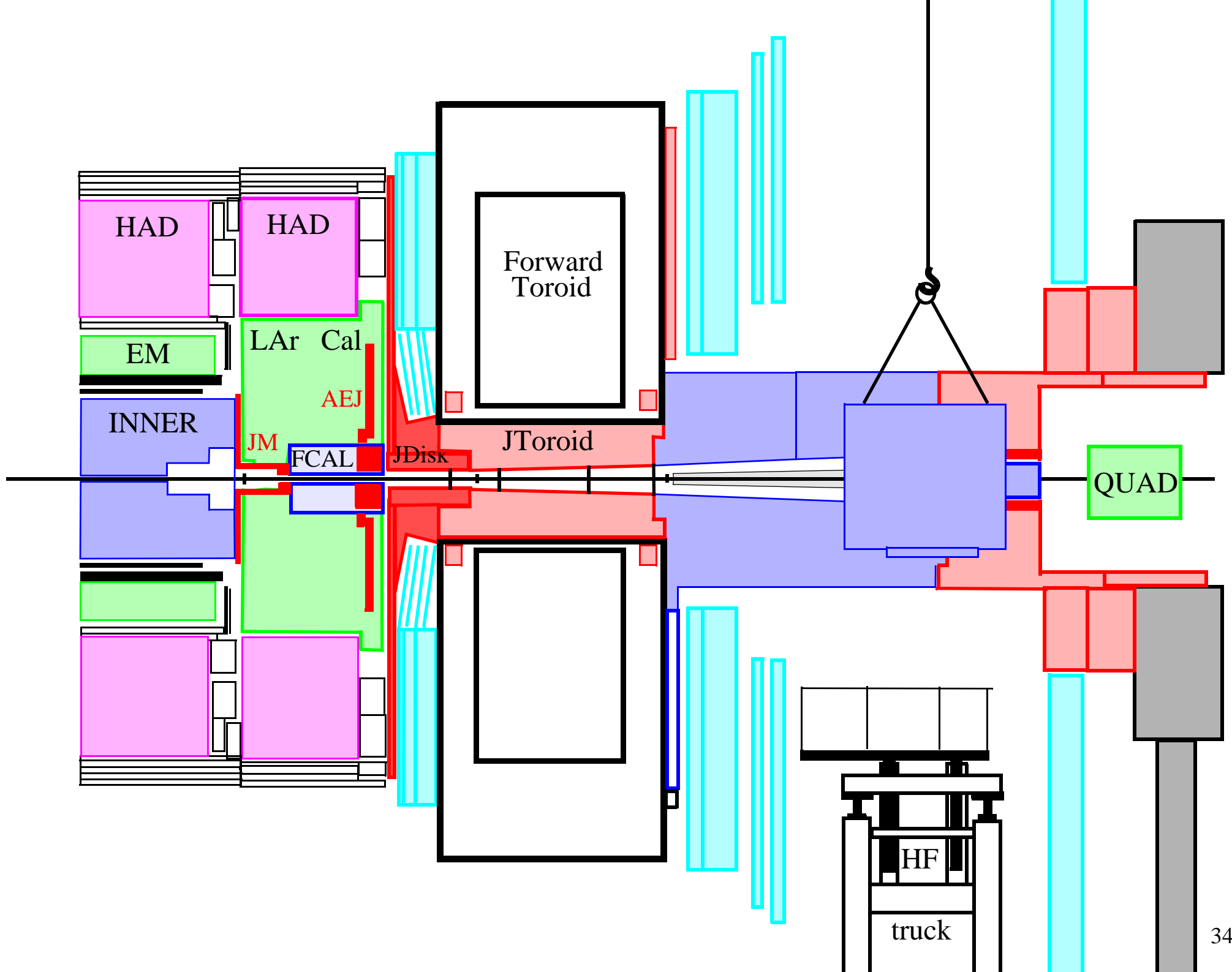

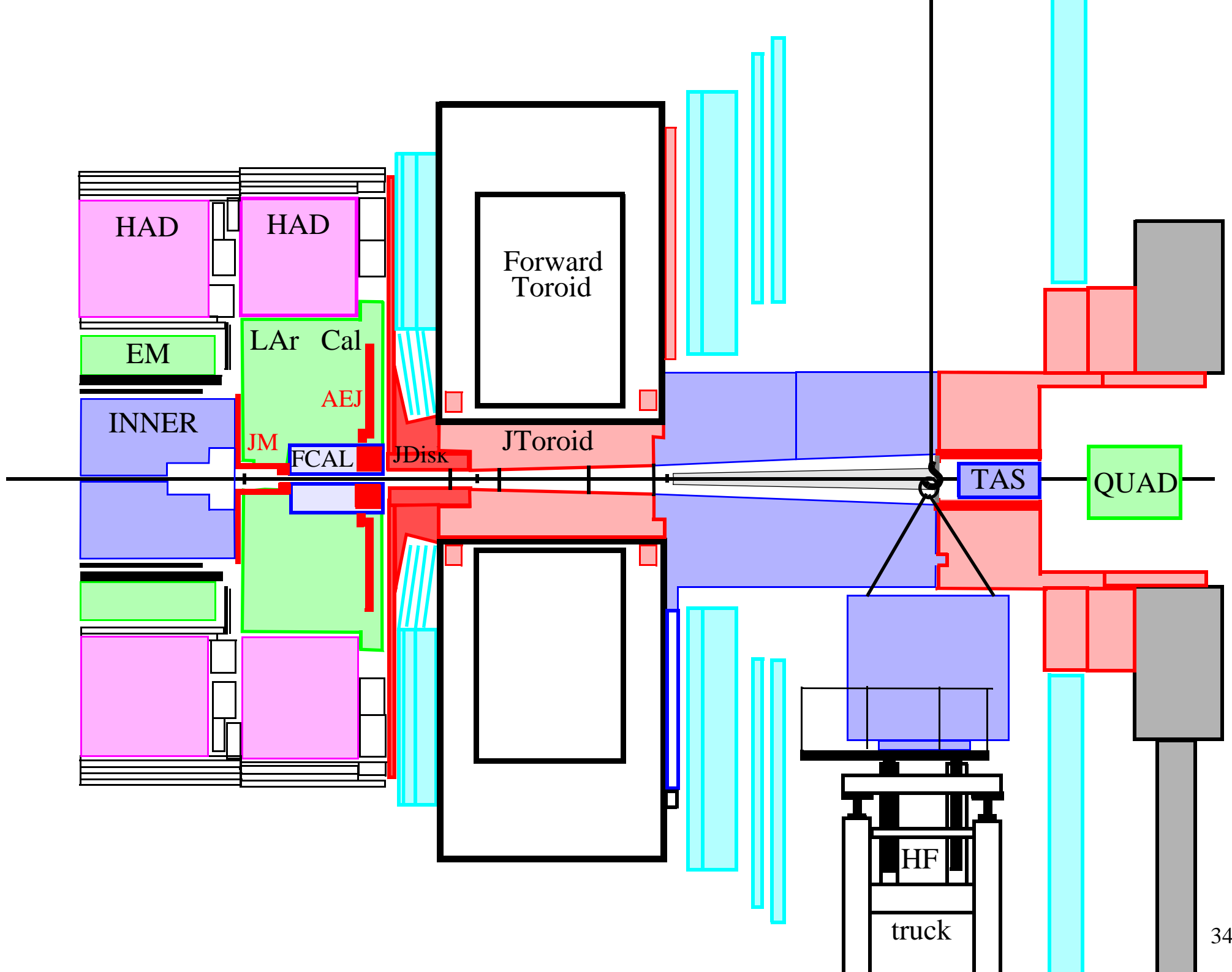

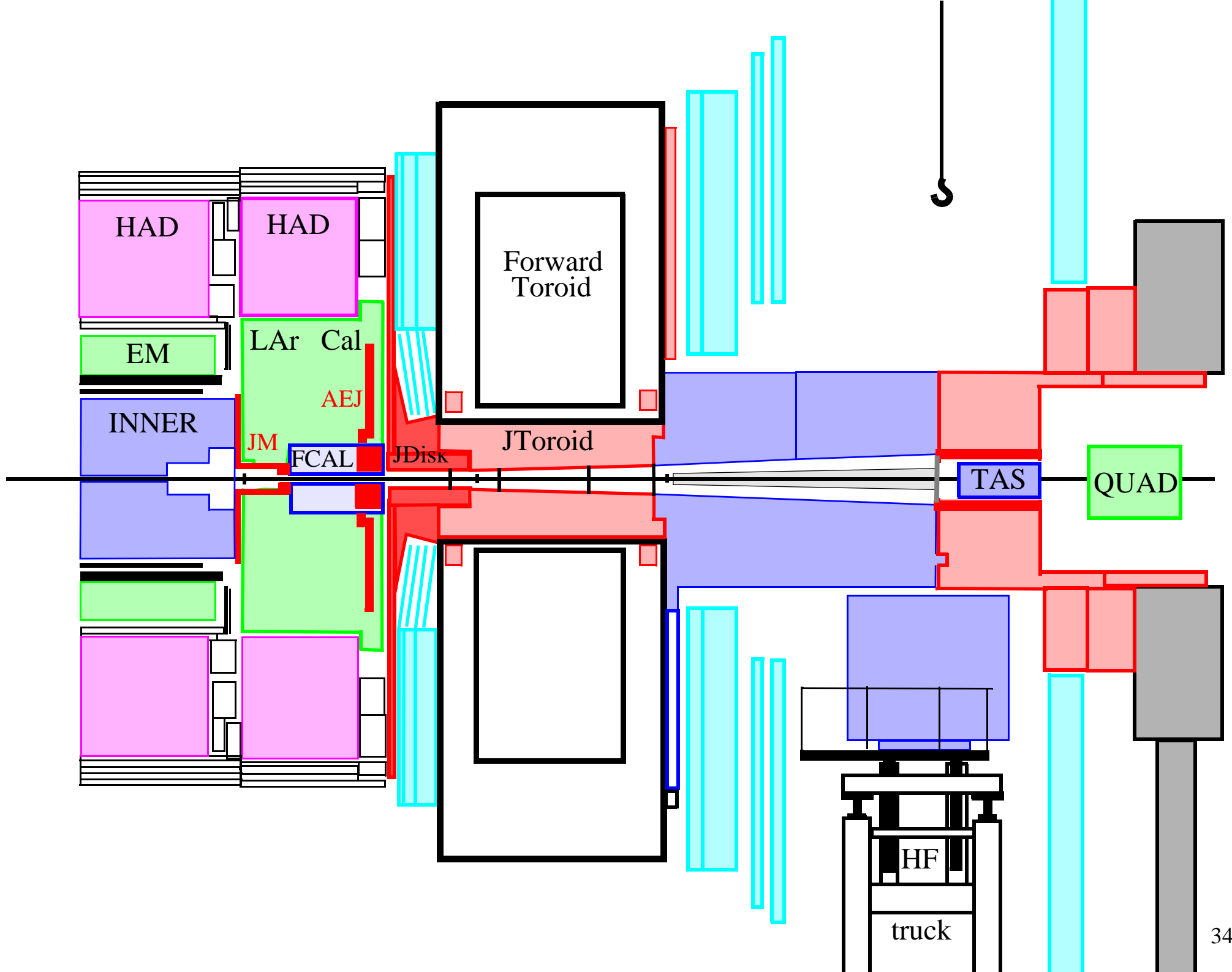

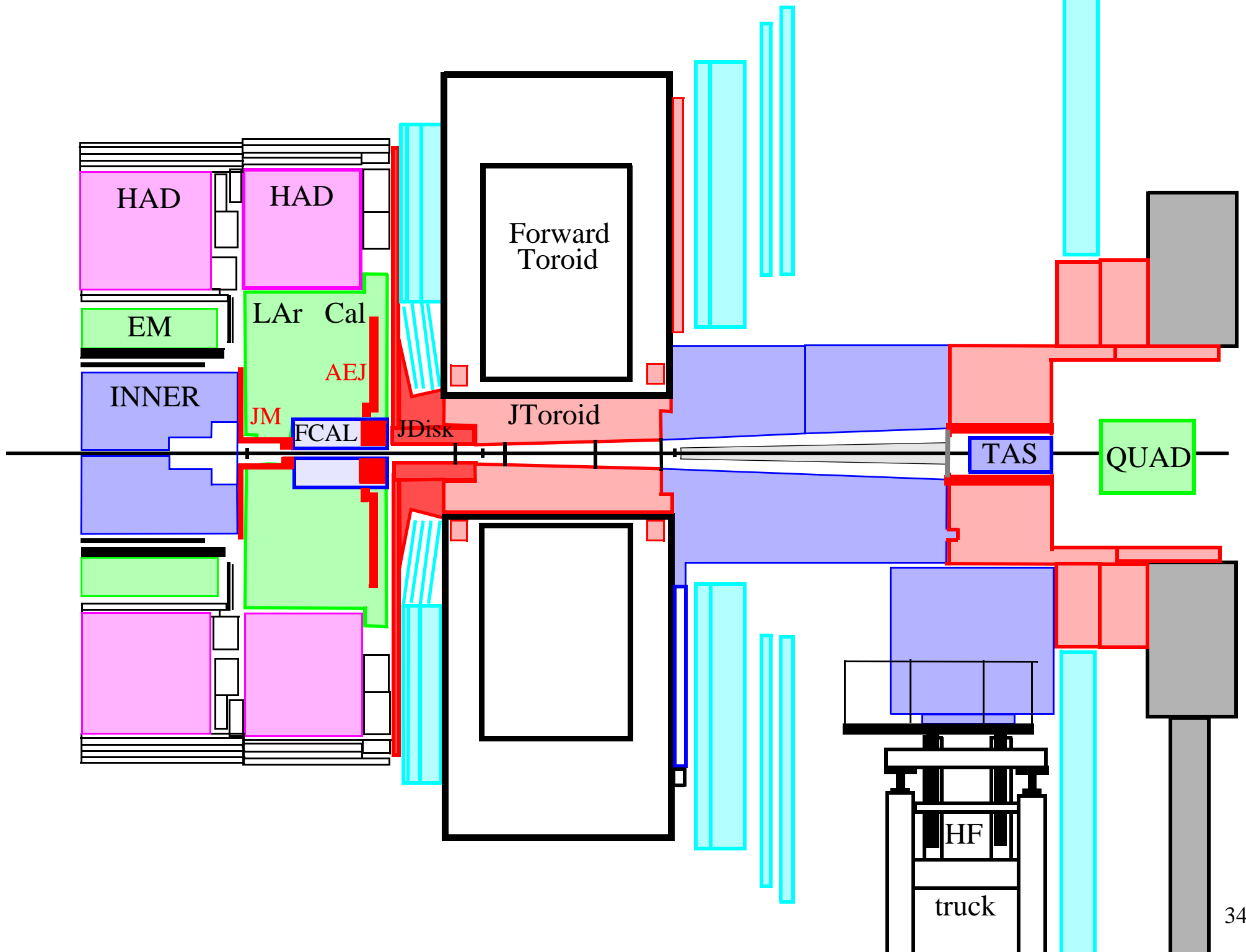

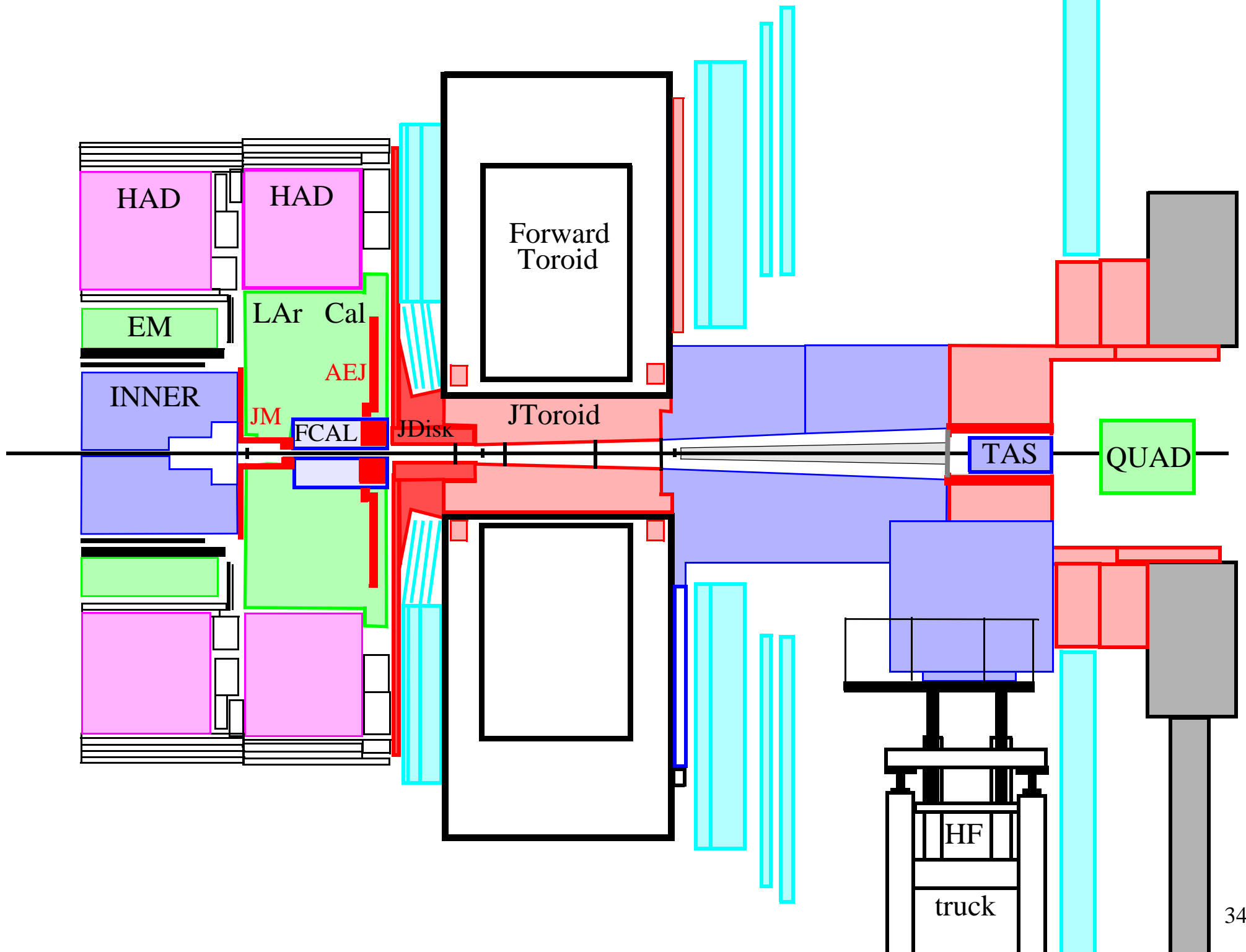

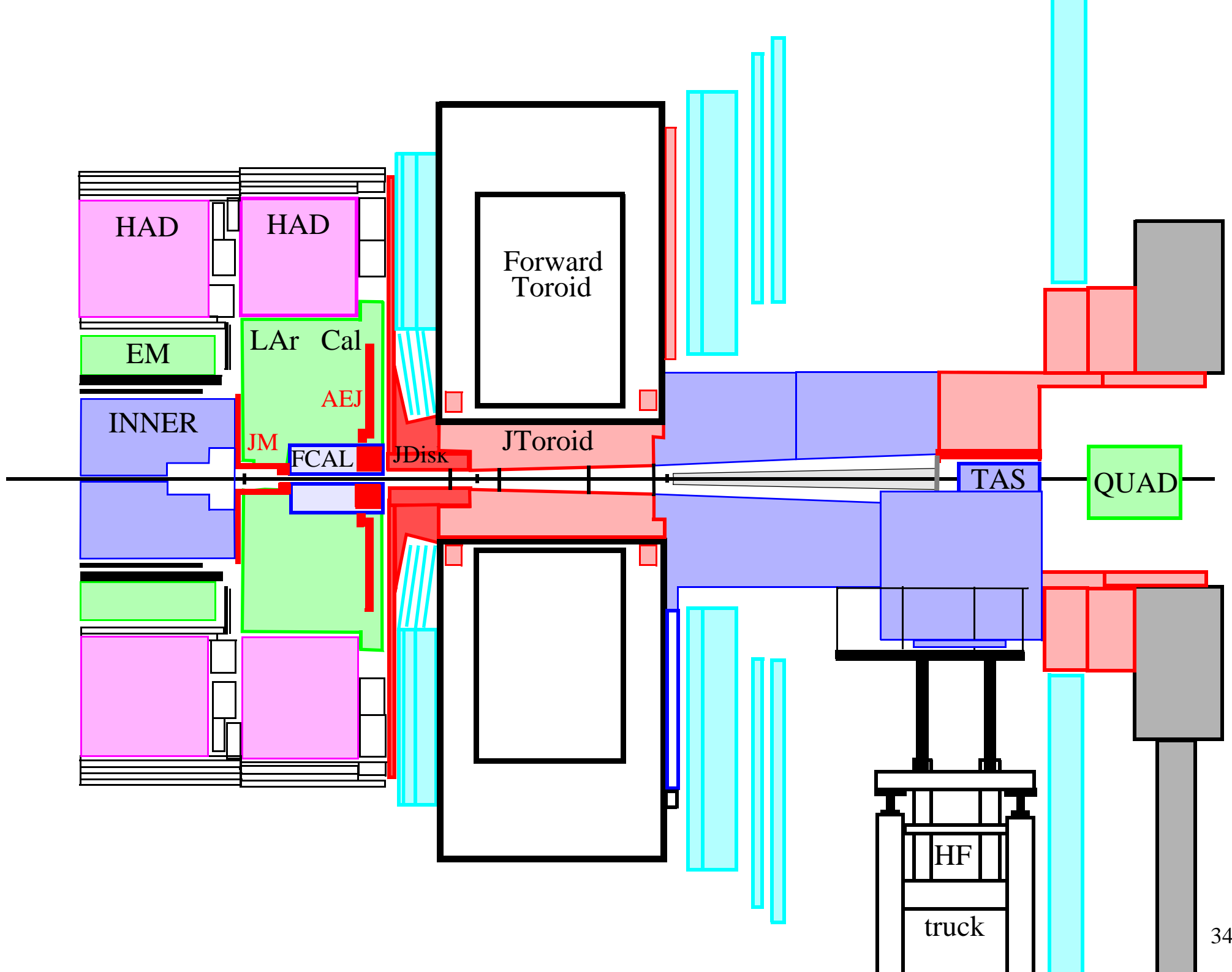

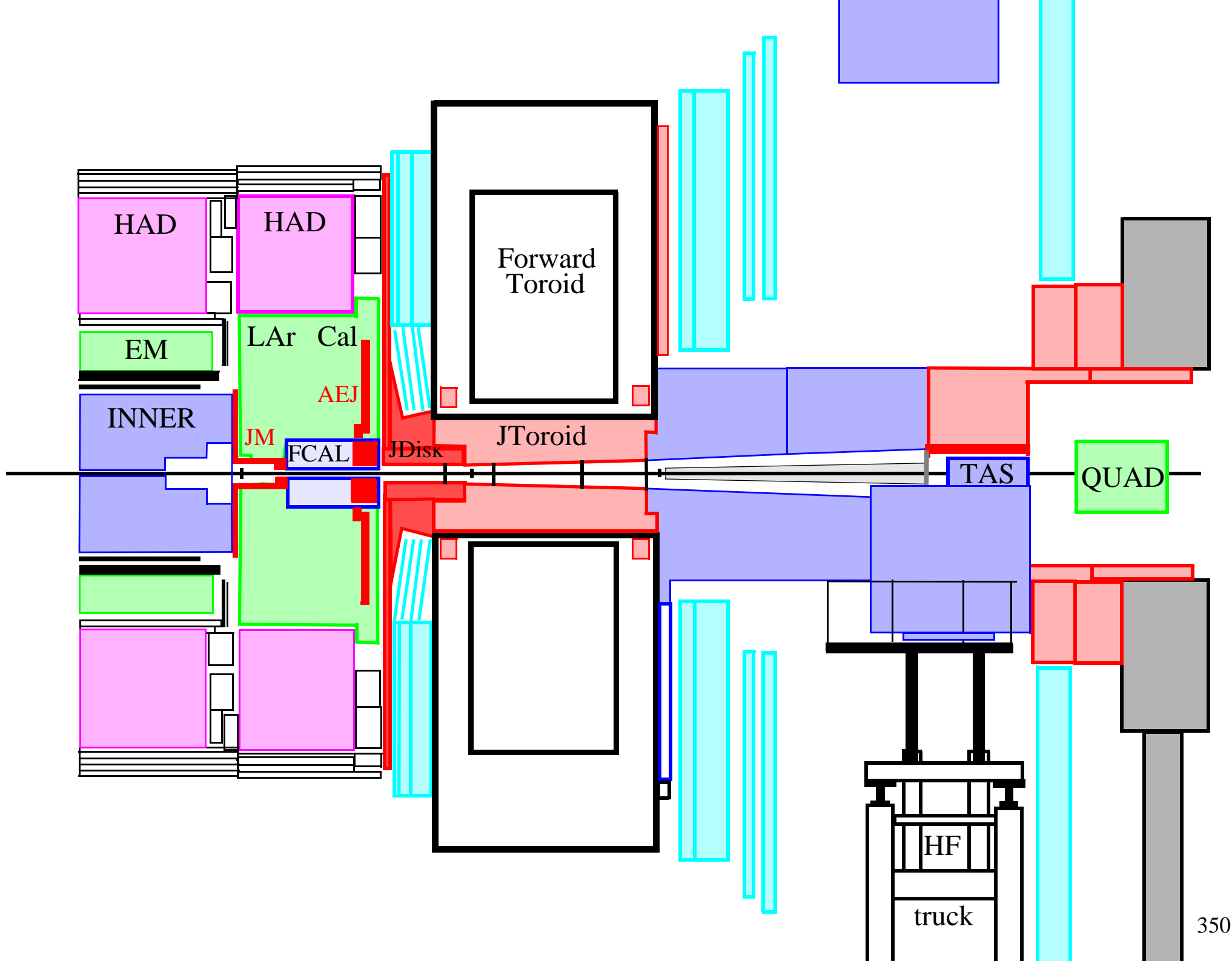

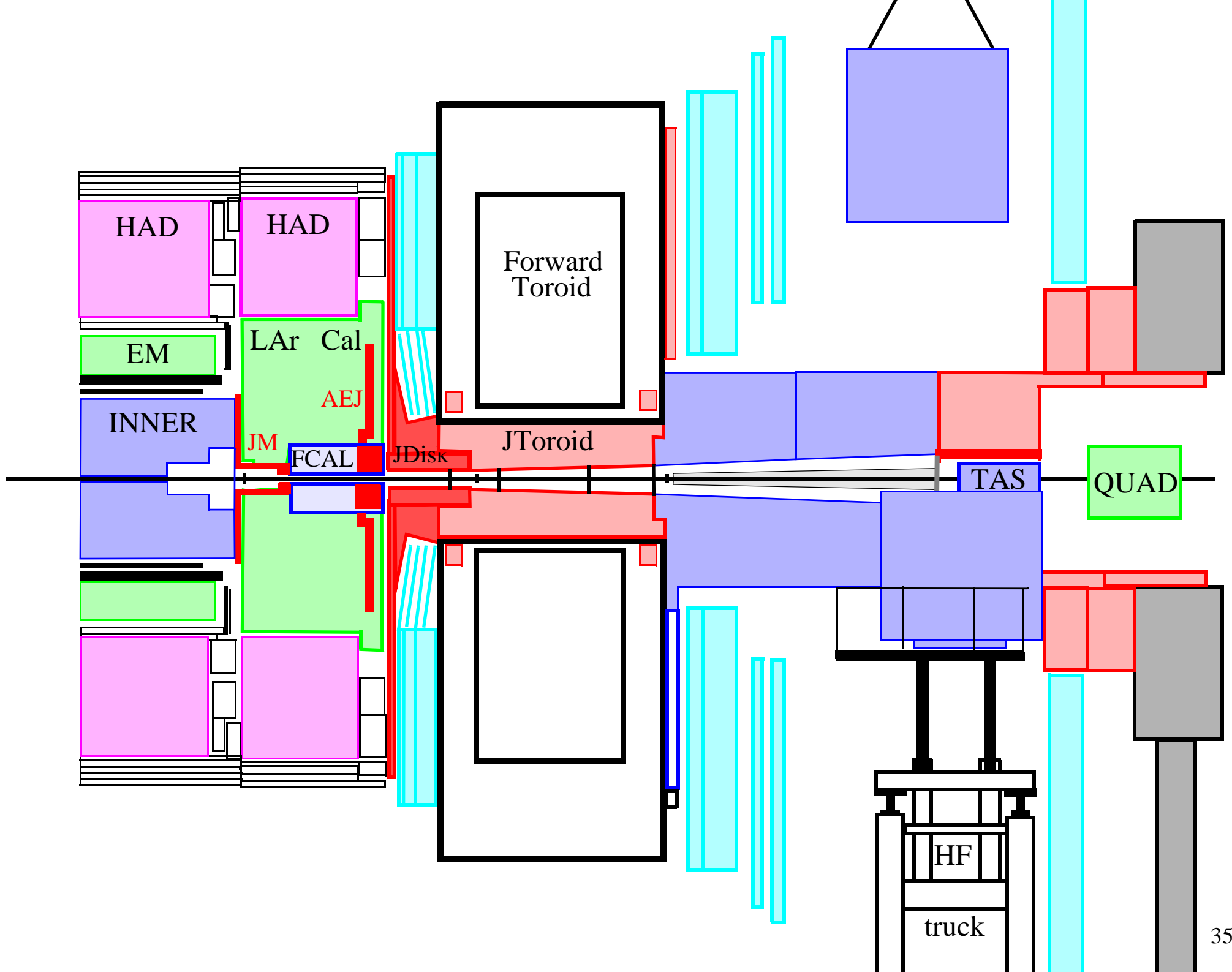

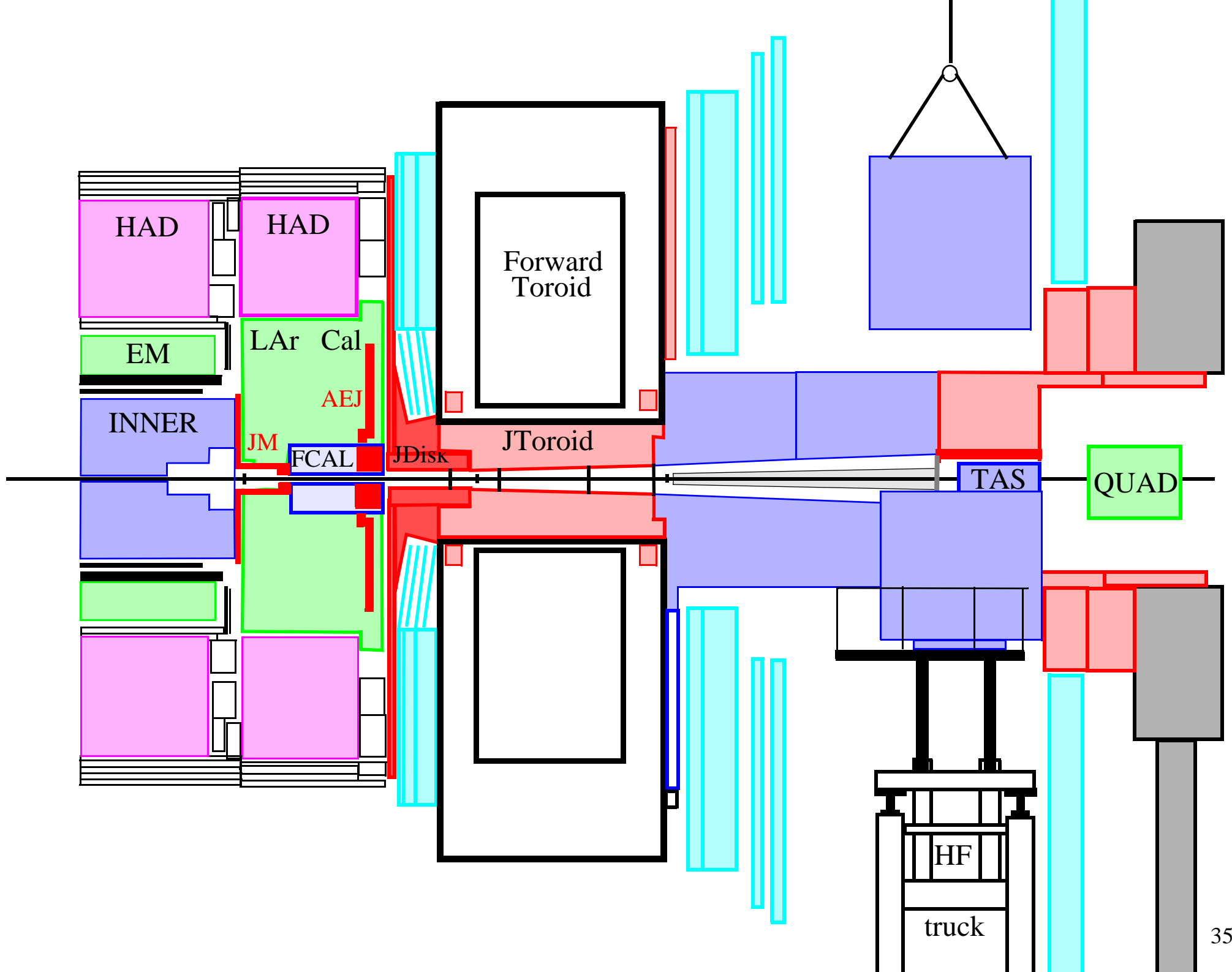

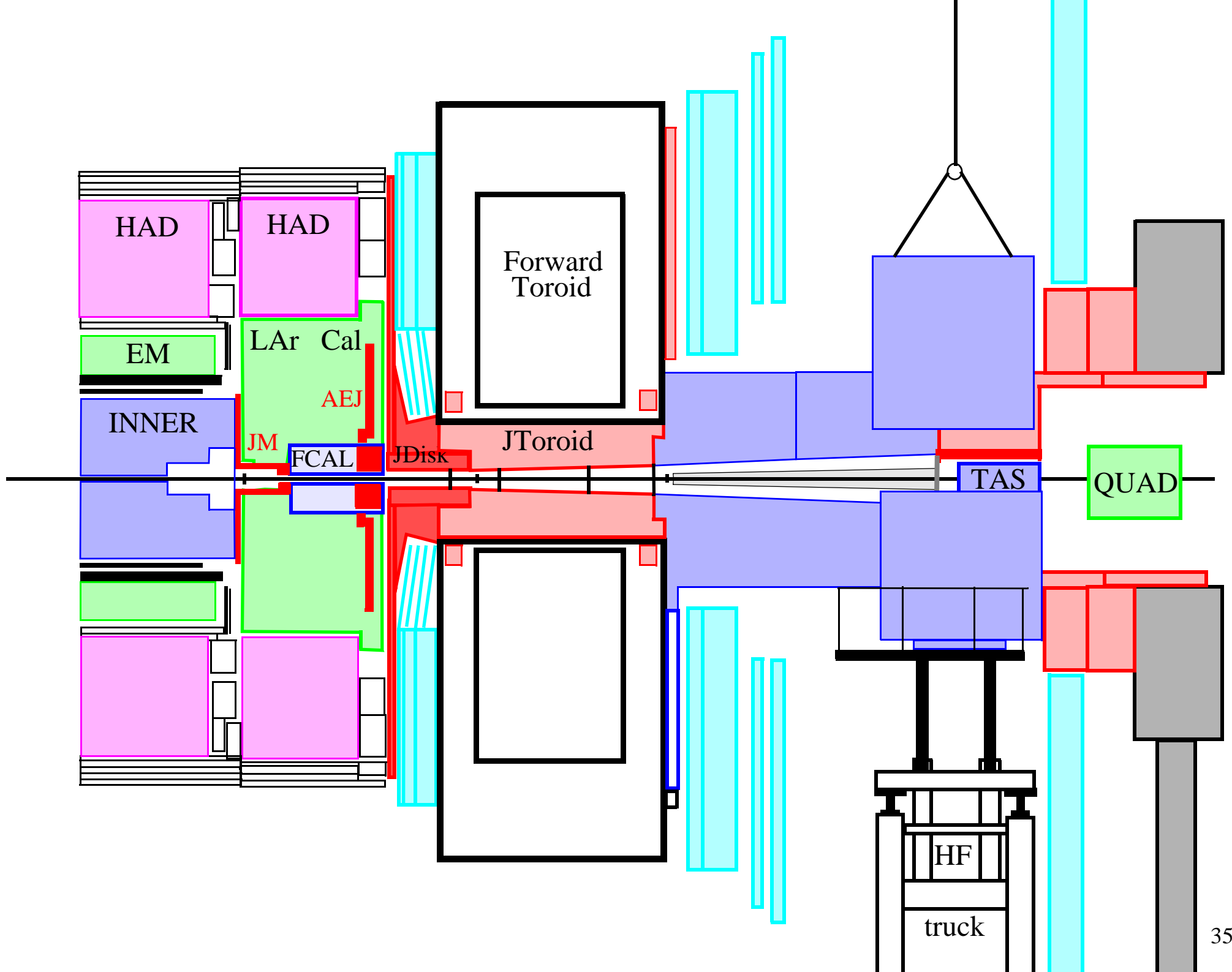

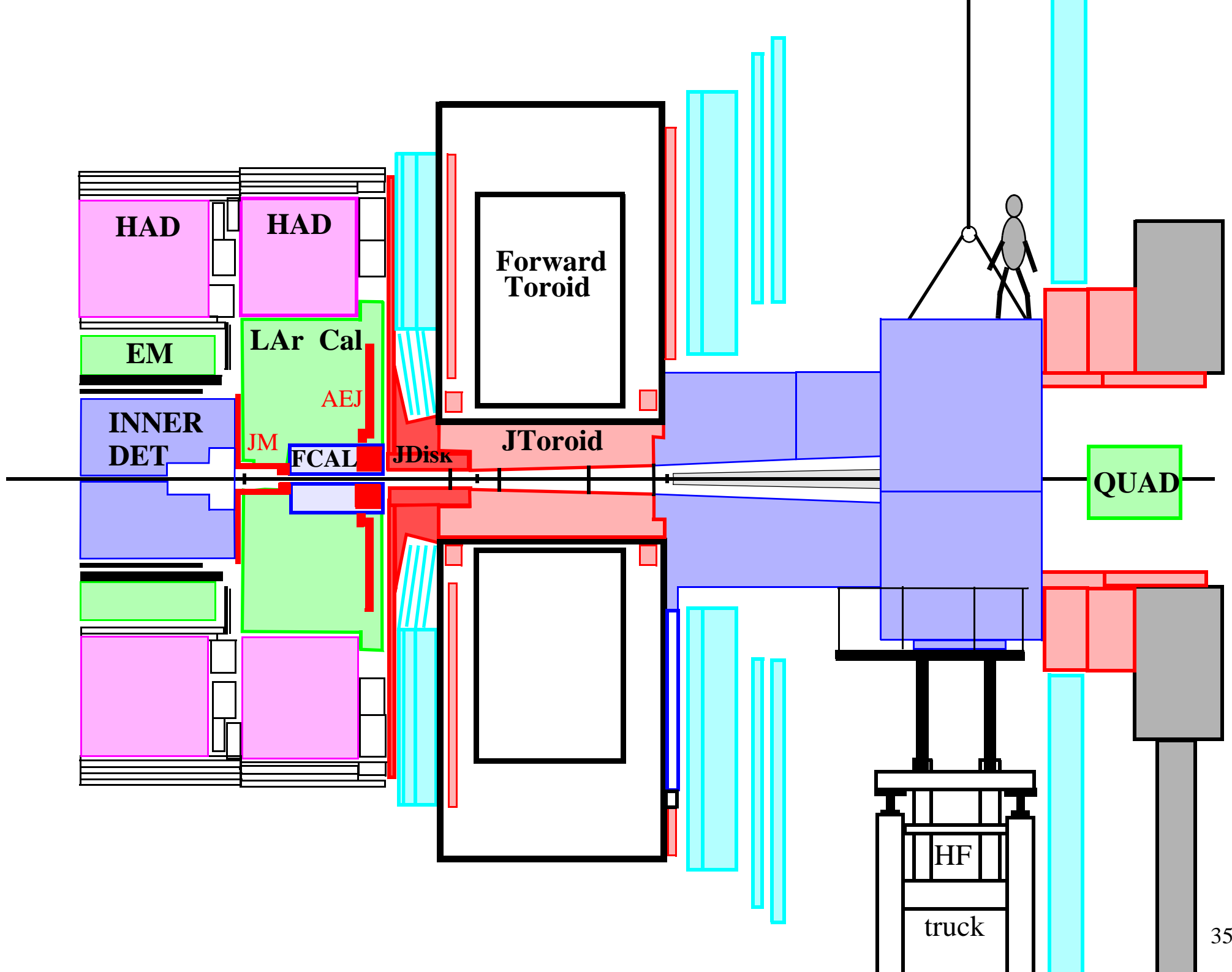

August 2007

